



OPTIVIEW™ REMOTE CONTROL CENTER

INSTALLATION, OPERATION & SERVICE

New Release

Form 50.40-OM2 (601)

OPTIVIEW™ REMOTE CONTROL CENTER

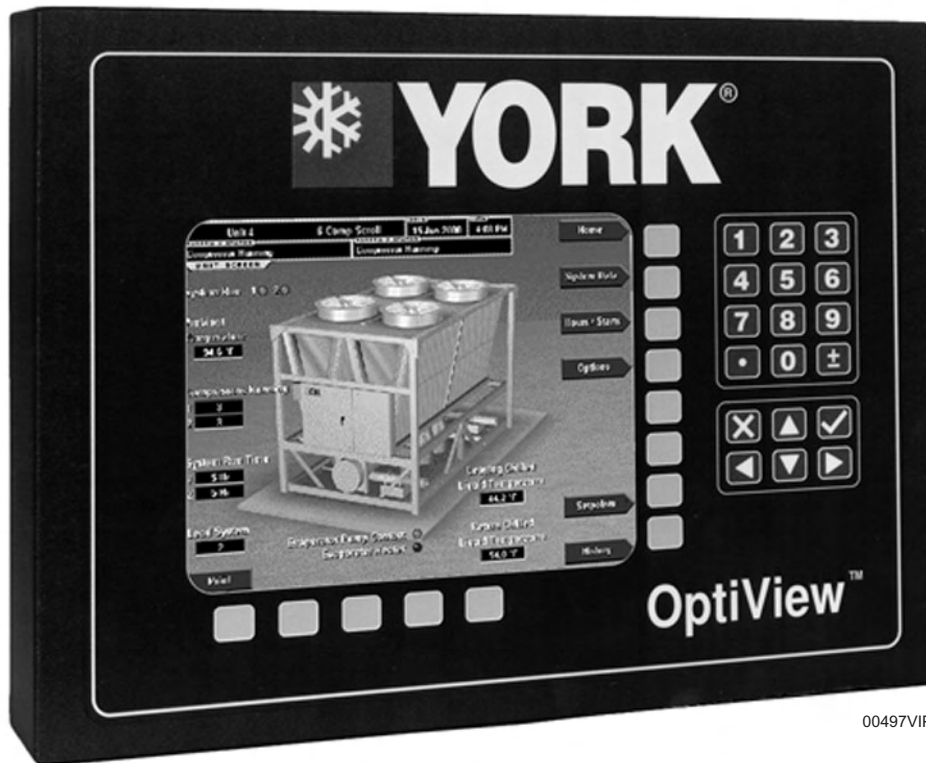

00497VIP

IMPORTANT!

READ BEFORE PROCEEDING!

GENERAL SAFETY GUIDELINES

This equipment is a relatively complicated apparatus. During installation, operation, maintenance or service, individuals may be exposed to certain components or conditions including, but not limited to: refrigerants, oils, materials under pressure, rotating components, and both high and low voltage. Each of these items has the potential, if misused or handled improperly, to cause bodily injury or death. It is the obligation and responsibility of operating/service personnel to identify and recognize these inherent hazards, protect themselves, and proceed safely in completing their tasks. Failure to comply with any of these requirements could result in serious damage to the equipment and the property in which it is situated, as well as severe

personal injury or death to themselves and people at the site.

This document is intended for use by owner-authorized operating/service personnel. It is expected that this individual possesses independent training that will enable them to perform their assigned tasks properly and safely. It is essential that, prior to performing any task on this equipment, this individual shall have read and understood this document and any referenced materials. This individual shall also be familiar with and comply with all applicable governmental standards and regulations pertaining to the task in question.

SAFETY SYMBOLS

The following symbols are used in this document to alert the reader to areas of potential hazard:



DANGER indicates an imminently hazardous situation which, if not avoided, will result in death or serious injury.



CAUTION identifies a hazard which could lead to damage to the machine, damage to other equipment and/or environmental pollution. Usually an instruction will be given, together with a brief explanation.



WARNING indicates a potentially hazardous situation which, if not avoided, could result in death or serious injury.

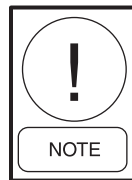

NOTE is used to highlight additional information which may be helpful to you.



External wiring, unless specified as an optional connection in the manufacturer's product line, is not to be connected inside the micro panel cabinet. Devices such as relays, switches, transducers and controls may not be installed inside the micro panel. No external wiring is allowed to be run through the micro panel. All wiring must be in accordance with YORK's published specifications and must be performed only by qualified YORK personnel. YORK will not be responsible for damages/problems resulting from improper connections to the controls or application of improper control signals. Failure to follow this will void the manufacturer's warranty and cause serious damage to property or injury to persons.

CHANGEABILITY OF THIS DOCUMENT

In complying with YORK's policy for continuous product improvement, the information contained in this document is subject to change without notice. While YORK makes no commitment to update or provide current information automatically to the manual owner, that information, if applicable, can be obtained by contacting the nearest YORK Applied Systems Service office.

It is the responsibility of operating/service personnel as to the applicability of these documents to the equipment in question. If there is any question in the mind of operating/service personnel as to the applicability of these documents, then, prior to working on the equipment, they should verify with the owner whether the equipment has been modified and if current literature is available.

TABLE OF CONTENTS

SECTION	1	PRODUCT DESCRIPTION 8 Chiller/Condensing Control Panel(s) 9	8
SECTION	2	INSTALLATION..... 10 Mounting 10 Installation Checklist 10 Wiring 10 Lan Transient Installation 14 Eprom Compatibility 14 Troubleshooting 14 Safety 14 Proper Installation Practices 15	10
SECTION	3	OPERATION..... 18 OptiView Remote Control Center 18 Screen Descriptions and Usage..... 19 Home Screen..... 22 Unit Screen 24 Systems Screen..... 29 Individual System Screen..... 32 Hours/Starts Screen 34 Options Screen 36 Trending Screen 38 Trend Setup Screen 40 Setpoints Screen 44 History Screen 47 History Details Screen 48 RCC Setpoints Screen 49 RCC Setup Screen 50 Comms Screen 52 Printer Screen 53 Diagnostics Screen 54 Diagnostics (I/O) Screen 55 Diagnostics (RCC Comms) Screen 56 Display Messages 58	18
SECTION	4	PRINTERS 59	59
SECTION	5	SERVICE 65 Introduction..... 65	65

System Architecture	66
Microboard.....	68
Microboard Program Jumpers	76
Microboard Program Switches	78
Liquid Crystal Display.....	81
Display Interface Board	87
Display Backlight Inverter Board	89
Keypad	91
Power Supply	94
Offline Diagnostics & Troubleshooting.....	96
Main Diagnostics	97
Keypad Test.....	98
Display Test	99
Bit Pattern Test	100
Serial Inputs / Outputs Tests	101
Digital Inputs / Outputs Tests	103
Analog Inputs Test	104
System Commissioning Checklist	105
SECTION 6 PART NUMBER AND RENEWAL PARTS.....	106

LIST OF TABLES

TABLE 1 – Required Software Version of the Chiller/Condensing Unit Eproms	11
TABLE 2 – Program Jumpers	76
TABLE 3 – Program Switches	78
TABLE 4 – Part Number	106
TABLE 5 – Renewal Parts	106

LIST OF FIGURES

FIG. 1 – EU DECLARATION OF CONFORMITY 7	FIG. 31 – MICROBOARD 73
FIG. 2 – FIELD WIRING 12	FIG. 32 – FLASH MEMORY CARD 74
FIG. 3 – CONTROL INSTALLATION 16	FIG. 33 – BLOCK DIAGRAM, MICROBOARD 75
FIG. 4 – GROUNDING 16	FIG. 34 – MICROBOARD LAMP DIMMER CIRCUIT 78
FIG. 5 – SEPARATE CONDUIT INSTALLATION 17	FIG. 35 – SERIAL DATA COMMUNICATIONS PORTS 79
FIG. 6 – POWER & GROUND WIRE CONNECTIONS 17	FIG. 36 – CONFIGURABLE ANALOG INPUTS 80
FIG. 7 – OPTIVIEW REMOTE CONTROL CENTER 18	FIG. 37 – DISPLAY, MOUNTING 84
FIG. 8 – SCREEN NAVIGATION LAYOUT 20	FIG. 38 – LCD TYPICAL CONTROL SIGNAL TIMING 84
FIG. 9 – HOME SCREEN 22	FIG. 39 – LG SEMICON LP104V2 DISPLAY ASSEMBLY - 85
FIG. 10 – UNIT SCREEN 24	FIG. 40 – SHARP LQ10D367 DISPLAY ASSEMBLY - 85
FIG. 11 – SYSTEMS SCREEN 29	FIG. 41 – SHARP LQ10D367 BACKLIGHT LAMP REPLACEMENT 86
FIG. 12 – INDIVIDUAL SYSTEM SCREEN 32	FIG. 42 – LG SEMICON LP104V2 BACKLIGHT LAMP REPLACEMENT 86
FIG. 13 – HOURS AND STARTS SCREEN 34	FIG. 43 – DISPLAY INTERFACE BOARD 88
FIG. 14 – OPTIONS SCREEN 36	FIG. 44 – DISPLAY BACKLIGHT INVERTER BOARD 90
FIG. 15 – TRENDING SCREEN 38	FIG. 45 – KEYPAD 92
FIG. 16 – TRENDING SETUP SCREEN 40	FIG. 46 – DIAGRAM, KEYPAD 93
FIG. 17 – SETPOINTS SCREEN 44	FIG. 47 – BLOCK DIAGRAM, DC POWER DISTRIBUTION. 95
FIG. 18 – HISTORY SCREEN 47	FIG. 48 – MAIN DIAGNOSTIC SCREEN 97
FIG. 19 – HISTORY DETAILS SCREEN 48	FIG. 49 – KEYPAD TEST SCREEN 98
FIG. 20 – RCC SETPOINTS SCREEN 49	FIG. 50 – DISPLAY TEST SCREEN 99
FIG. 21 – RCC SETUP SCREEN 50	FIG. 51 – BIT PATTERNS TEST SCREEN 100
FIG. 22 – COMMS SCREEN 52	FIG. 52 – SERIAL INPUTS/OUTPUTS TESTS SCREEN 101
FIG. 23 – PRINTER SCREEN 53	FIG. 53 – DIGITAL INPUTS/OUTPUTS TESTS SCREEN 103
FIG. 24 – DIAGNOSTICS SCREEN 54	FIG. 54 – ANALOG INPUTS TEST SCREEN 104
FIG. 25 – DIAGNOSTICS I/O SCREEN 55	FIG. 55 – FRONT OF OPTIVIEW RCC 107
FIG. 26 – DIAGNOSTICS RCC COMMS SCREEN 56	FIG. 56 – INSIDE OF OPTIVIEW RCC 107
FIG. 27 – PRINTERS 59	FIG. 57 – INSIDE DOOR OF OPTIVIEW RCC 108
FIG. 28 – EXAMPLE PRINTOUT (OPERATING DATA) 63	FIG. 58 – LOCATION OF FUSE, F1 & F2 109
FIG. 29 – EXAMPLE PRINTOUT (HISTORY HEADER) 64	
FIG. 30 – CONTROL CENTER BLOCK DIAGRAM 67	



P.O. Box 1592, York, Pennsylvania USA 17405-1592

EU DECLARATION OF CONFORMITY

The EU Directives covered by this Declaration:

89/336/EEC Electromagnetic Compatibility Directive amended by 92/31/EEC & 93/68/EEC.
72/23/EEC Low Voltage Equipment Directive amended by 93/68/EEC.

The Products Covered by this Declaration:

PRODUCT NAME: OptiView Remote Control Center (RCC)
MODEL NUMBER: 371-02750-1nn (nn is used to define software functionality)

The Basis on which Conformity is being Declared:

The product identified above complies with the requirements of the above EU Directives by meeting the following standards:

EMC:

FCC Part 15 Conducted
FCC Part 15 Radiated
EN55011 : 1991 Conducted
EN55011 : 1991 Radiated
EN 61000-3-2 : 1995 Harmonics
EN 61000-3-3 : 1995 Flickermeter
EN 61000-4-2 : 1995 Electrostatic Discharge
EN 61000-4-3 : 1997 Radiated RF EM Field-AM Modulation
ENV 50204 : 1995 Radiated RF EM Field-Pulse Modulation
EN 61000-4-4 : 1995 Electrical Fast Transient/Burst
EN 61000-4-5 : 1995 Surge Immunity
EN 61000-4-6 : 1996 Conducted RF Disturbances
EN 61000-4-8 : 1993 Power Frequency Magnetic Field

Safety:

EN 60204-1 :1993 Electrical
Equipment of Machines

The technical documentation required to demonstrate that the product meets the requirements of the EMC Directive and Low Voltage Directive has been compiled by the signatory below and is available for inspection by the relevant enforcement authorities. The CE mark was first applied in: 2000

The products described above comply with the essential requirements of the directives specified.

European Contact:

Signature & Date: A. Abdalla 12/14/00

Printed Name: A. ABDALLA

Function: HEAD OF PROJ. DESIGN & DEV.

U.S. Contact:

Signature & Date: J.C. Hansen 12/14/00

Printed Name: J.C. HANSEN

Function: ENGINEERING MANAGER

ATTENTION!

The attention of the specifier, purchaser, installer, or user is drawn to special measures and limitations to use which must be observed when the product is taken into service to maintain compliance with the above directives. Details of these special measures and limitations to use are available on request, and are also contained in the product manuals.

FOR COMPLIANCE INFORMATION ONLY:

European Contact:
Head of ESG product design & development Europe
Gardiners Lane South
Basildon, Essex, SS14 3HE United Kingdom
Telephone (44) 1268 246000, Fax (44) 1268 246001

US Contact:
Electronics Engineering Manager
P.O. Box 1592-231C
York, PA 17405-1592 United States
Telephone 717-771-6457, Fax 717-771-7498

FIG. 1 – EU DECLARATION OF CONFORMITY

SECTION 1 – PRODUCT DESCRIPTION

The YORK OptiView Remote Control Center is a microprocessor based control system capable of remotely monitoring certain chillers and condensing units. It can monitor and individually control 1 to 8 of these chiller/condensing units.

The panel comes configured with a full screen color LCD Graphic Display mounted in the middle of a keypad interface. The graphic display allows the presentation of the current information all at once. In addition, the operator may view a graphical representation of several operating parameters. For the novice user, the locations of various parameters are clearly and intuitively marked. Instructions for specific operations are provided on many of the screens.

The graphic display also allows information to be represented in Imperial units (temperatures in °F and pressures in PSIG or PSID) or SI units (temperatures in °C and pressures in BARG or BARD).

All values that are modifiable at the Remote Control Center are recorded in memory and preserved even through a power failure condition. During operation, the chillers are continually polled and the user is advised of the operating conditions by various status and warning messages. A complete listing of shutdown, status, and warning messages is within the chiller/condensing unit's operation manual.

If the chiller/condensing unit is in remote control mode the OptiView Remote Control Center provides the capability to program the following:

1. Start Command
2. Stop Command
3. Local Setpoint
4. Local Control Range
5. Daily/Holiday Schedule
6. Current or Load Limit Setpoint

The Remote Control Center is also designed to enable the user to obtain chiller/condensing unit printouts directly from this panel.

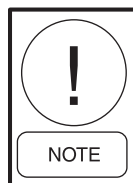

This equipment has been tested and found to comply with the limits for a Class A digital device, pursuant to part 15 of the FCC Rules. These limits are designed to provide reasonable protection against harmful interference when the equipment is operated in a commercial environment. This equipment generates, uses, and can radiate radio frequency energy and, if not installed and used in accordance with the instruction manual, may cause harmful interference to radio communications. Operation of this equipment in a residential area is likely to cause harmful interference in which case the user will be required to correct the interference at his own expense.

CHILLER/CONDENSING CONTROL PANEL(S)

All communication with the chiller/condensing units will occur over a single RS-485 port. Reference Figure 2 and the Installation instructions.

When the OptiView RCC is first turned on it will initialize by requesting current data and history buffer information from the units connected. After the history buffers are filled, only current data will be continuously requested. Every eight hours the OptiView RCC will re-initialize. If the control panel updates the history buffer (a safety shutdown has occurred), the control panel will send the chiller shutdown data to the OptiView RCC upon receipt of the next valid OptiView RCC transmission. The OptiView RCC will recognize that a safety shutdown has occurred by the Update History Buffer bit being set. If this bit is ever 1, the data dump is assumed to be a shutdown data dump and the OptiView RCC will update its history buffers with the new data and start a printout of the transmitted data through its RS232 port. If the OptiView RCC had been requesting another type of data dump (i.e. a daily schedule dump), the OptiView RCC will repeat its request on the next transmission.

While at the Home Screen, the OptiView RCC will communicate with each unit in order. Once a unit has been selected by entering the Unit Screen or any screen below it, that unit will be polled between every unit in order. This will allow the selected unit to update its information quickly while still maintaining information for the Home Screen.

A command string is used to indicate what data the OptiView RCC is requesting and to modify control data in the chiller control panel. If the chiller/condensing unit is in remote control mode then its Local Set Point, Local Range, Daily Schedule, Holiday, Start

/ Stop Command, and Current / Load Limit can be programmed from the OptiView RCC. The OptiView RCC will send a command string once any of these are modified at the OptiView RCC. If the OptiView RCC sends a Stop command, the chiller/condensing unit will turn off. If the OptiView RCC sends a start command, the chiller/condensing unit will be allowed to run if all the other run requirements of the unit are made.

A chiller/condensing unit that is in remote control mode will use local control (set points and start / stop information), if a valid transmission has not been received for 5 minutes from the OptiView RCC. The remote commands will be used again once a valid new transmission has been processed. The OptiView RCC will display an error message indicating the communications problem when such a condition occurs.

A general status message for each unit is displayed on the Home Screen. The messages displayed will include communications status. **Not Initialized** will be displayed upon power-up for all units until the OptiView RCC begins to poll and receive data from that unit. **Initializing...** will be displayed while the OptiView RCC is polling a unit for all current, schedule, and history data the first time after power-up. **Loss of Comms** will be displayed after 5 minutes have elapsed with no response from a previously initialized unit. If any of these messages is displayed, the unit's button will be disabled not allowing it to be selected.

The Control Center Microboard (J12) communicates with this board via a 0/+5VDC serial data communications link. If this communications link does not operate properly, correct Microboard J12 serial port operation can be verified using the Serial Inputs and Outputs diagnostic procedure in the "Service" section of this book.

SECTION 2 – INSTALLATION

MOUNTING

Mount the Remote Control Center at a level that provides for easy viewing of the color graphic display by all users. Securely mount it at the desired location. The panel may be mounted away from the chiller as far as 4000 ft. (1219 m.) of wiring will allow.

INSTALLATION CHECKLIST

(Reference Fig. 2 for wiring)

- A communications cable must connect the OptiView RCC to the chiller/condenser control panel. This cable should be a three-conductor with foil shield and drain wire, 20 awg or larger wire, 300v, 80 Deg. C, UL Style 2464, UL listed and CSA approved. Three sources are Alpha 5463, Belden 9364, or Quabbin 0220. The cable length (sum of lengths of all cables) must not exceed 4000 ft. (1219 m.). The cable is user supplied.
- Obtain ferrite (part number 025-35154-000) from the cloth bag found in the OptiView RCC and install it as shown on Fig. 2. This must be installed to meet FCC and CE requirements.
- Make sure that the Transient Voltage Suppressors are installed at J12. One is installed from “+” to “GND” and one is installed from “-” to “GND”.
- At J12 of the OptiView RCC, red wire on RS485(+), black wire on RS485(-) and white wire on Ground.
- At the OptiView RCC, connect the shield to the panel.
- Use a tie wrap between the J12 connector and the Ferrite (part number 025-35154-000) to secure the shielded cable to the OptiView RCC. The tie wrap can help prevent the wires from being accidentally pulled out of the J12 connector by someone working in the panel or by the weight of the ferrite.
- Install a LAN transient protection module at the chiller/condenser control panel and connect the cable according to the type of control panel.
- Make sure the correct EPROM is installed at the chiller/condenser control panel(s). See Table 1.
- From the Setpoints Screen of the OptiView RCC, enter the Number of Units Connected (Maximum value allowed is 8).

- At the chiller/condenser control panel that uses a rotary switch to set the ID, use a small screw driver to rotate the rotary switch so that the arrow points at the number that coincides with the Unit’s Identification number (ID#). Unit 1 - Unit 8 coincide to rotary switches 0 - 7. Otherwise program the panel’s ID through keypad entry.

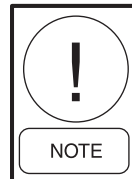

Never skip an ID#. For example, if you have four units then they must be identified from ID#0 - ID#3.

- At the chiller/condenser unit’s control panel, select the type of control mode. Select REMOTE only if remote control is desired. Select LOCAL to only monitor this unit.
- From the Comms Screen of the OptiView RCC, enter the RCC Poll Time. This is how often (time in seconds) to request data. This time should be set long enough to allow for receiving the data.

WIRING

A communications cable must connect the chiller to the remote panel. This cable should be a three-conductor with foil shield and drain wire, 20 awg or larger sized wire, 300v, 80 Deg. C, U.L. Style 2464, U.L. listed and CSA approved. Three sources are Alpha 5463, Belden 9364, or Quabbin 0220. The cable length (sum of lengths of all cables) must not exceed 4000 ft. (1219 m.).

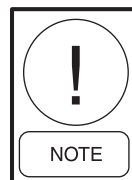

Never run the communication cable in close proximity to any power wiring. For best results, it should be run in dedicated, grounded conduit. See Proper Installation Practices.

REQUIRED SOFTWARE VERSION OF THE CHILLER / CONDENSING UNIT EPROMS

TABLE 1 – REQUIRED SOFTWARE VERSION OF THE CHILLER/CONDENSING UNIT EPROMS

UNIT TYPE	EPROM PART NO.	VERSION
YCAL /YCUL w/microboard 031-01314-000	031-02011-001	C.MMC.01.05
YCAL /YCUL w/microboard 031-02050-000	031-02049-001	C.MMC.03.02
YCAS - F 2 Compressors	031-01798-001	C.ACS.09.03
YCAS - F 3 & 4 Compressors	031-01798-002	C.ACS.10.02
YCAR 2 Compressors	031-02013-001	C.RCP.23.02

The software version is printed on a label adhered to the EPROM chip's surface. A revision level higher than the one listed in the table is acceptable. An example version code is as follows:

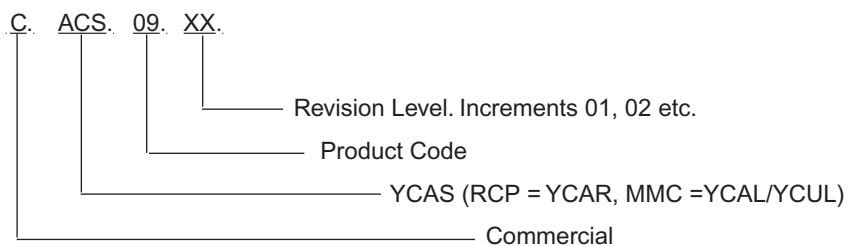

OPTIVIEW REMOTE CONTROL CENTER

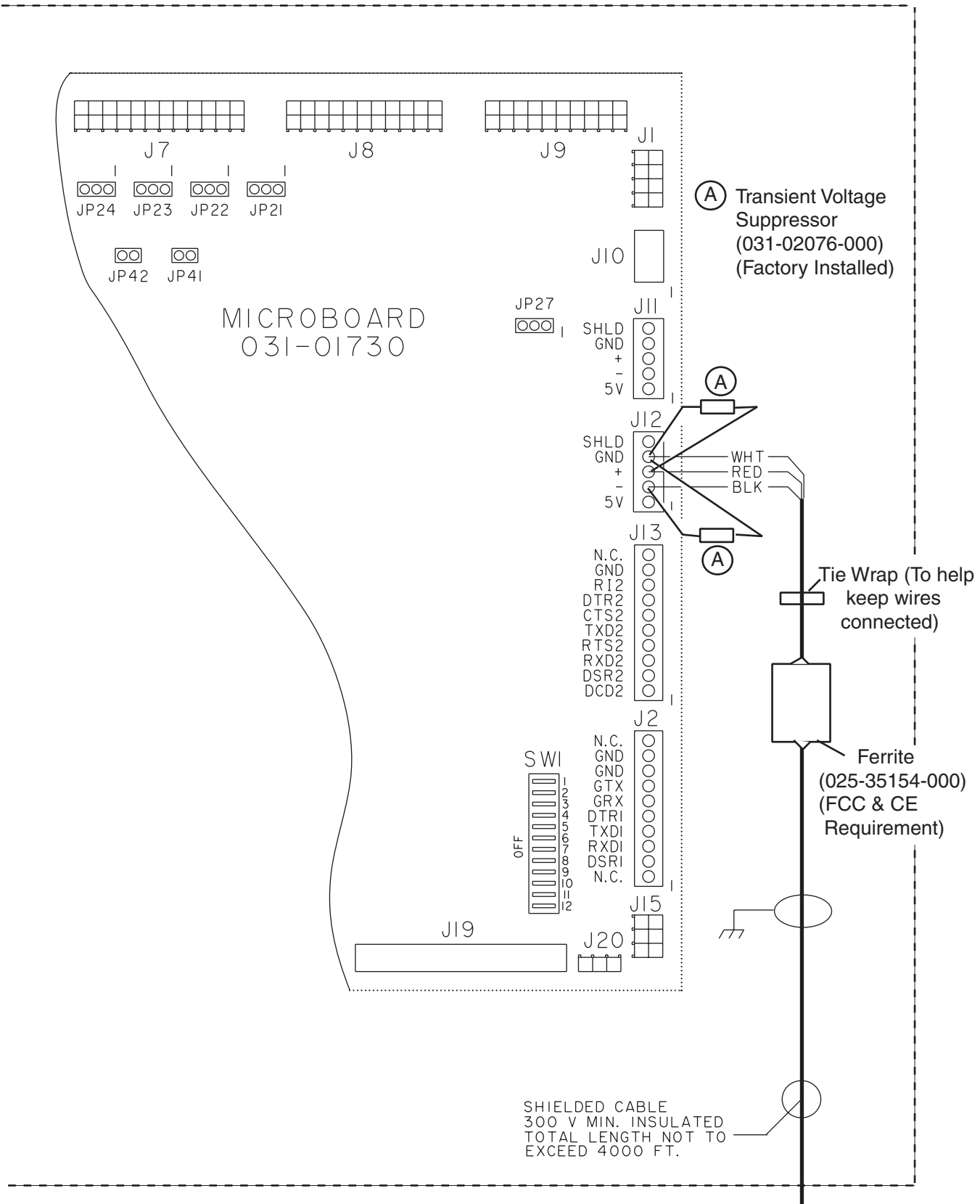

LD06725

FIG. 2 – FIELD WIRING OPTIVIEW RCC PANEL

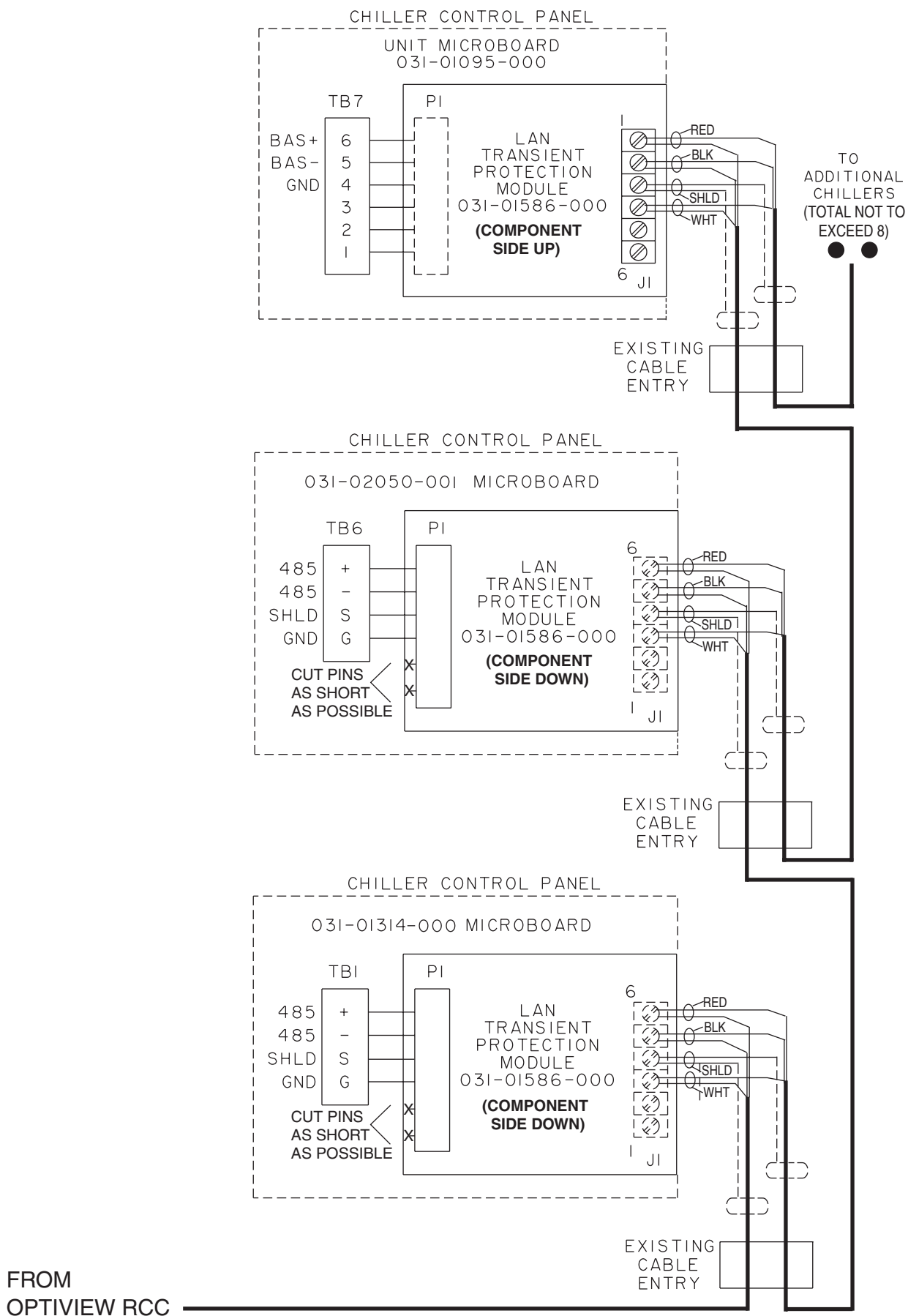

LD06726

FIG. 2 – FIELD WIRING OPTIVIEW RCC PANEL (CONT.)

LAN TRANSIENT INSTALLATION

The properly installed Lan Transient Protection Module, (part number 031-01586-000) will limit the voltage levels seen by the chiller control panel's RS-485 driver while allowing normal RS-485 network operation under non-transient conditions. For installation of the module refer to Fig. 2 and the specific installation instructions for the microboard.

Unit Microboard 031-01314-000 and 031-02050-001:

Step 1: Label all wires, cables, or components connected to TB1.

Step 2: Carefully loosen each terminal of TB1. Remove all wires, cables, or components. Be extremely careful to not allow them to short together or to the enclosure.

Step 3: Refer to the Module. Replace all wires, cables, or components taken from TB1 into the correct terminals of the Module terminal strip J1 being extremely careful to not allow them to short together or to the enclosure.

Step 4: Carefully tighten all screws on the Module Terminal strip J1.

Step 5: Orient the Module as shown (component side down) and cut the unused pins. Insert the four P1 Module pins into TB1 as shown.

Step 6: Carefully tighten each terminal of TB1. Double check all wiring to the Module before closing up.

Unit Microboard 031-01095-000:

Step 1: Label all wires, cables, or components connected to TB7.

Step 2: Carefully loosen each terminal of TB7. Remove all wires, cables, or components. Be extremely careful to not allow them to short together or to the enclosure.

Step 3: Replace all wires, cables, or components taken from TB7 into the Module terminal strip J1 being extremely careful to not allow them to short together or to the enclosure.

Step 4: Carefully tighten all screws on the Module Terminal strip J1.

Step 5: Orient the Module as shown (component side up) and insert all six P1 Module pins into TB7 as shown.

Step 6: Carefully tighten each terminal of TB7. Double check all wiring to the Module before closing up.

EPROM COMPATIBILITY

Since the concept and design of the OptiView Remote Control Center may have occurred after the original EPROM (software) for the chiller/condenser control panel, the EPROM may need to be replaced with one that allows for OptiView Remote Control Center operation. See Table 1.

TROUBLESHOOTING

From the Home Screen you can determine if you are communicating to the chiller/condensing unit.

If the message **Not Initialized..** remains shown on this screen, proper communication between the panels has not occurred and you will need to troubleshoot.

Step 1: If you are trying to communicate with more than one unit, simplify the troubleshooting by isolating the communication to one unit at a time. Remove any wiring to a secondary unit and from the Setpoints Screen of the OptiView RCC, enter one as the Number of Units Connected and at the chiller/condenser control panel set it's ID to zero.

Step 2: Check if there is any communication problem occurring on the Diagnostic RCC Comms Screen. See the description of this screen.

You could also check that the RX3 I/O communication activity LED on the OptiView Main Processor Board is blinking as it receives data from the chiller/condensing unit's control panel. A steady lit RX3 LED is a sign of improper wiring. If the RX3 LED is not blinking check the wiring and the installation of the Lan Transient Protection Module. If everything is properly connected replace the 485 driver on the chiller/condenser microboard (part number 031-02074-000).

SAFETY

It is recommended that all maintenance and service repair work be performed by experienced personnel. There must be recognition of the potential hazards that can exist. Those hazards may include (but are not limited to):



There can be electrical circuitry that presents an electrocution hazard. Be sure that the sources of all power supplies have been properly isolated and secured before attempting any service related activities.



External wiring, unless specified as an optional connection in the manufacturer's product line, is not to be connected inside the OptiView Remote Control Center cabinet. Devices such as relays, switches, transducers and controls may not be installed inside the OptiView Remote Control Center. No external wiring is allowed to be run through the OptiView Remote Control Center. All wiring must be in accordance with YORK's published specifications and must be performed only by qualified YORK personnel. YORK will not be responsible for damages/problems resulting from improper connections to the controls or application of improper control signals. Failure to follow this will void the manufacturer's warranty and cause serious damage to property or injury to persons.

PROPER INSTALLATION PRACTICES

Earlier relay systems were virtually immune to radio frequency interference (RFI), electromagnetic interference (EMI), and ground loop currents. Installation consisted of hooking up the point-to-point wiring and sizing the wire properly.

In an electronic system, improper installation will cause problems that outweigh the benefits of electronic control. Electronic equipment is susceptible to RFI, EMI, and ground loop currents which can cause equipment shutdowns, processor memory and program loss, erratic behavior, and false readings. Manufacturers of industrial electronic equipment take into consideration the effects of RFI, EMI, and ground loop currents and incorporate protection of the electronics in their designs. These manufacturers require that certain installation precautions be taken to protect the electronics from these effects. All electronic equipment must be viewed

as sensitive instrumentation and therefore requires careful attention to proper installation procedures.

There are a few basics, that if followed, will result in a trouble-free installation. The National Electric Code (N.E.C.) is a guideline for safe wiring practices, but it does not deal with procedures used for electronic control installation. Use the following procedures for electronic equipment installation. These procedures are to be used in conjunction with the N.E.C.

Wire Sizing

Size supply wires one size larger than required for amperage draw to reduce instantaneous voltage dips caused by large loads such as heaters, contactors and solenoids. Sudden dips in voltage can cause the processor to momentarily malfunction or cause a complete reset of the control system. If the wire is loaded to its maximum capacity, the voltage dips are much larger, and the potential for a malfunction is very high. If the wire is sized one size larger than required, the voltage dips are smaller than in a fully loaded supply wire, and the potential for malfunction is much lower.

The NEC code requires specific wire sizes to be used based on current draw. An example would be to use #14 gauge wire for circuits up to 15 amp or #12 gauge wire for circuits of up to 20 amp. Therefore, when connecting the power feed circuit to an electronic industrial control, use #12 gauge wire for a maximum current draw of 15 amp and #10 wire for a maximum current draw of 20 amp.

Voltage Source (Figure 3)

Selecting the voltage source is extremely important for proper operation of electronic equipment in an industrial environment. Standard procedure for electronic instrumentation is to provide a "clean" separate source voltage in order to prevent EMI, from other equipment in the plant, from interfering with the operation of the electronic equipment. Connecting electronic equipment to a breaker panel (also known as lighting panels and fuse panels) subjects the electronic equipment to noise generated by other devices connected to the breaker panel. This noise is known as electromagnetic interference (EMI). EMI flows on the wires that are common to a circuit. EMI cannot travel easily through transformers and therefore can be isolated from selected circuits. Use a control transformer to isolate the electronic control panel from other equipment in the plant that generate EMI.

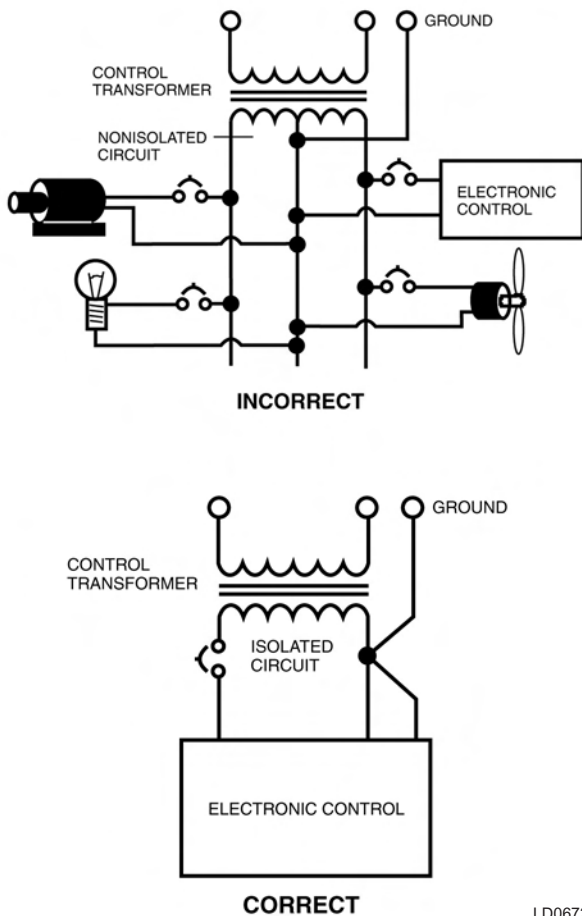

FIG. 3 – CONTROL INSTALLATION

Grounding

Grounding is the most important factor for successful operation. Electronic equipment reacts to very small currents and must have a good ground in order to operate properly. The NEC states that control equipment may be grounded by using the rigid conduit as a conductor. This is not acceptable for electronic control equipment. Conduit is a poor conductor compared to a copper wire. Copper grounds are required for proper operation.

Ground Wire Size (Figure 4)

The ground wire must be the same size as the supply wires or one size smaller as a minimum. The three phase power brought into the plant must also have a ground wire, making a total of four wires. In many installations that are having electronic control problems, this essential wire is usually missing. A good ground circuit must be continuous from the plant source transformer to the electronic control panel for proper operation. Driving a ground stake at the electronic control will cause additional problems since other

equipment in the plant on the same circuits will ground themselves to the ground stake causing large ground flow at the electronic equipment.

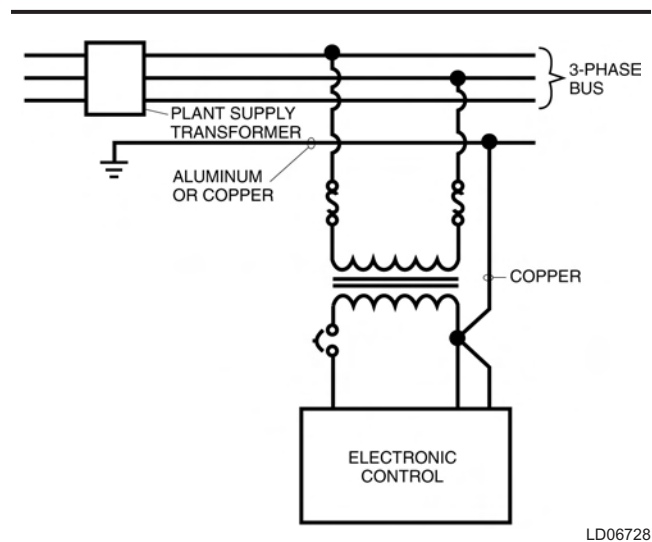

FIG 4 – GROUNDING

Wiring Practices (Figure 5)

Do not mix wires of different voltages in conduit. For an example refer to Figure 5. The motor voltage is 480 volts and the panel control power is 120 volts. The 480 volt circuit must be run from the motor starter to the motor in its own conduit. The 120 volt circuit must be run from the motor starter control transformer to the control panel in its own separate conduit. If the two circuits are run in the same conduit, transients on the 480 volt circuit will be inducted into the 120 volt circuit causing functional problems with the electronic control. Dividers must be used in wire way systems (conduit trays) to separate unlike voltages. The same rule applies for 120 volt wires and 220 volt wires. Also, never run low voltage wires in the same conduit with 120 volt wires.

Never run any wires through an electronic control panel that do not relate to the function of the panel. Electronic control panels should never be used as a junction box. These wires may be carrying large transients that will interfere with the operation of the control.

When running conduit to an electronic control panel, note that the access holes (knockouts) are strategically placed so that the field wiring does not interfere with the electronics in the panel. **Never allow field wiring to come in close proximity with the controller boards since this will almost always cause problems.**

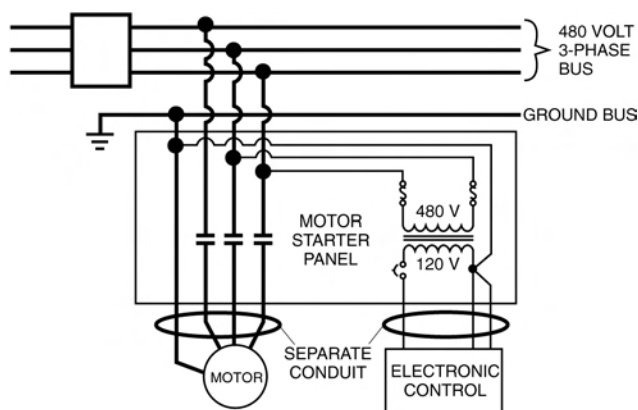

LD06738

FIG. 5 – SEPARATE CONDUIT INSTALLATION

Do not drill a control panel to locate conduit connections. Drilling can cause metal chips to land in the electronics and create a short circuit. If you must drill the panel, take the following precautions:

1. Call the panel manufacturer, if possible, before drilling the panel to be sure you are entering the panel at the right place.
2. Cover the electronics with plastic. Tape the plastic to the board with masking or electrical tape.
3. Place masking tape or duct tape on the inside of the panel at the point of drill bit entry.
4. Remove all of the remaining chips from the panel before removing the protective plastic.

When routing conduit to the top of an electronic control panel, condensation must be taken into consideration. Water can condense in the conduit and run into the panel causing catastrophic failure. **Route the conduit to the sides or bottom of the panel and use a conduit drain.** If the conduit must be routed to the top of the panel, use a sealable conduit fitting which is poured with a sealer after the wires have been pulled, terminated and the control functions have been checked. **A conduit entering the top of the enclosure must have an “O” ring-type fitting between the conduit and the enclosure,** so that if water gets on top of the enclosure, it cannot run in between the conduit and the enclosure. This is extremely important in outdoor applications.

Never add relays, starters, timers, transformers, etc. inside an electronic control panel without first contacting the manufacturer. Contact arcing and EMI emitted from these devices can interfere with the electronics. If you need to add these devices contact the manufacturer for the proper device types and placement.

Never run refrigerant, water or brine tubing inside an electronic control panel. A leak could damage or in some cases totally destroy the electronics.

If the electronic control panel has a starter built into the same panel, be sure to run the higher voltage wires where indicated by the manufacturer. EMI from the wires can interfere with the electronics if run too close to the circuitry.

Never daisy-chain or parallel-connect power or ground wires to electronic control panels. Each electronic control panel must have its own supply wires back to the power source. Multiple electronic control panels on the same power wires create current surges in the supply wires which can cause controller malfunctions. Daisy-chaining ground wires allows ground loop currents to flow between electronic control panels which also causes malfunctions. (See Figure 6)

It is very important to read the installation instructions thoroughly before beginning the project. Make sure you have drawings and instructions with your equipment. If not, call the manufacturer and have them send you the proper instructions. Following correct wiring procedures will ensure proper installation of your electronic equipment.

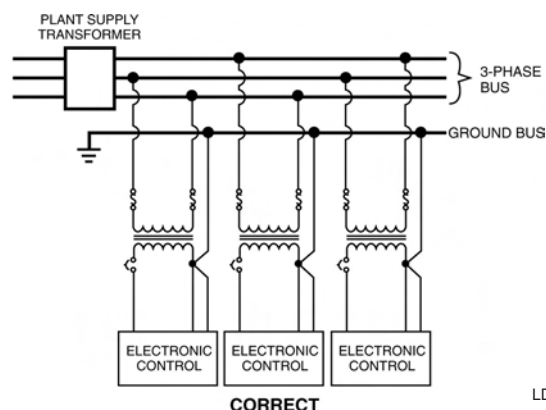

LD06739

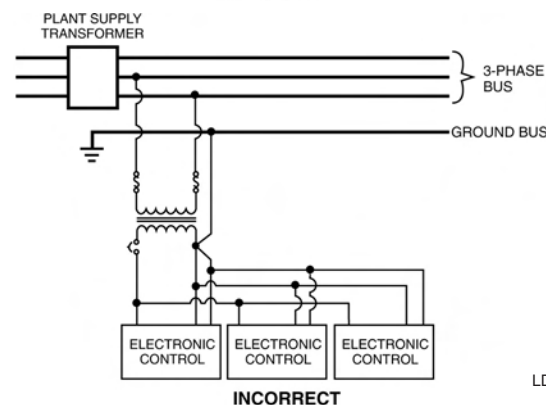

LD06740

FIG. 6 – POWER & GROUND WIRE CONNECTIONS

SECTION 3 – OPERATION OPTIVIEW REMOTE CONTROL CENTER

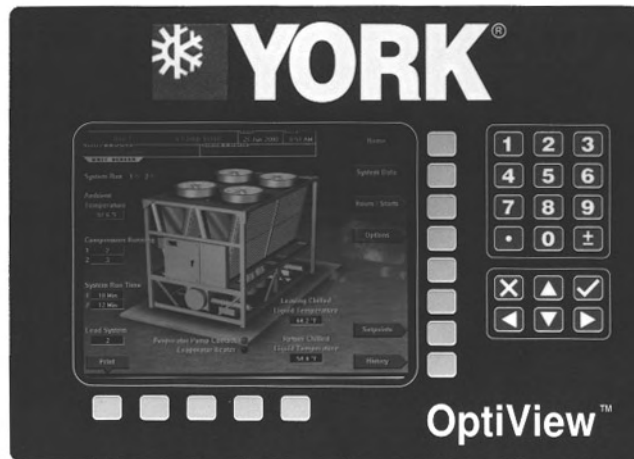





FIG. 7

00500VIP

The OptiView Remote Control Center display is highlighted by a full screen graphics display. This display is nested within a standard keypad, and is surrounded by “soft” keys which are redefined based on the currently displayed screen. Eight buttons are available on the right side of the panel, and are primarily used for navigation between the system screens. At the base of the display are 5 additional buttons. The area to the right of the keypad is used for data entry with a standard numeric keypad provided for entry of system setpoints and limits.

 The *Decimal* key is used prior to entering decimal values.

 A +/- key has also been provided to allow entry of negative values and AM/PM selection during time entry.

 In order to accept changes made to the chiller setpoints, the *Check* key is provided as a universal ‘Enter’ key or ‘Accept’ symbol.

 In order to reject entry of a setpoint or dismiss an entry form, the ‘X’ key is provided as a universal ‘Cancel’ symbol.

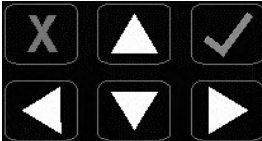
 *Cursor Arrow* keys are provided to allow movement on screens which contain a large amount of entry data. In addition, these keys can be used to scroll through history and event logs.

SCREEN DESCRIPTIONS AND USAGE

OVERVIEW

The new graphical display on each control panel allows a wide variety of information to be presented to the user. Each screen description in this document will begin with a section entitled **Overview** which will describe the graphical elements on the screen and give a short summary of the functions available. Each element on the screen will then be categorized into three distinct groups: Display Only, Programmable, and Navigation. Below is a short description of what types of information are included in these groups.

DISPLAY ONLY

Values in this group are read-only parameters of information about chiller operation. This type of information may be represented by a numerical value, a text string, or an LED image. For numerical values, if the monitored parameter is above the normal operating range, the high limit value will be displayed along with the '>' symbol; if it is below the normal operating range, the low limit value will be displayed along with the '<' symbol. In some cases, the value may be rendered invalid by other conditions and the display will use X's to indicate this.

PROGRAMMABLE

Values in this group are available for change by the user if the chiller/condensing unit is in remote mode. If there are no values that can be changed then "None" is shown.

Setpoint / Change Schedule

On screens containing programmable setpoints, a key with one of these labels will be visible. This key allows the user to modify setpoints on that screen.

Setpoints

Setpoint values are used to control chillers/condensing units and other devices connected to the units. Setpoints can fall into several categories. They could be numeric values (such as 45.0°F for the Leaving Chilled Liquid Temperature), or they could Enable/Yes or Disable/No a feature or function.

Regardless of which setpoint is being programmed, the following procedure applies:

1. Press the desired setpoint key. A dialog box appears displaying the present value, the upper and lower limits of the programmable range, and the default value.
2. If the dialog box begins with the word "ENTER", use the numeric keys to enter the desired value. Leading zeroes are not necessary. If a decimal point is necessary, press the '•' key (i.e. 45.0).

Pressing the ▲ key, sets the entry value to the default for that setpoint. Pressing the ▼ key, clears the present entry. The ◀ key is a backspace key and causes the entry point to move back one space.

If the dialog box begins with "SELECT", use the ◀ and ▶ keys to select the desired value.

If the previously defined setpoint is desired, press the 'X' (Cancel) key to dismiss the dialog box.

3. Press the '✓' (Enter) key.

If the value is within range, it is accepted and the dialog box disappears. The chiller will begin to operate based on the new programmed value. If out of range, the value will not be accepted and the user is prompted to try again.

Manual Controls

Some keys are used to perform manual control functions. These may initiate/terminate processes such as a report.

Free Cursor

On screens containing many setpoints, a specific "soft" key may not be assigned to each setpoint value. A soft key will be assigned to enable the cursor arrow keys below the numeric keypad which are used to "highlight" the desired setpoint field. At this point, the '✓' key is pressed to bring up a dialog prompting the user to enter a new setpoint value. The 'X' key cancels cursor mode. (See "Change Schedule" from the Setpoints Screen for an example.)

NAVIGATION

In order to maximize the amount of values which the panel can display to the user, and in order to place those values in context, multiple screens have been designed to describe each unit's operation. In order to move from one screen to the next, navigation keys have been defined. These keys allow the user to either

move “forward” to a sub-screen of the present screen, or move “backward” to the previous screen. Except for the Home Screen display, the upper-right “soft” key will always return the user to the Home Screen. Navigating with “soft” keys is as simple as pressing the key next to the label containing the name of the desired screen. The system will immediately refresh the display with the graphics for that screen. Following is a layout of all the screens and how they are connected.

Home (page 22)

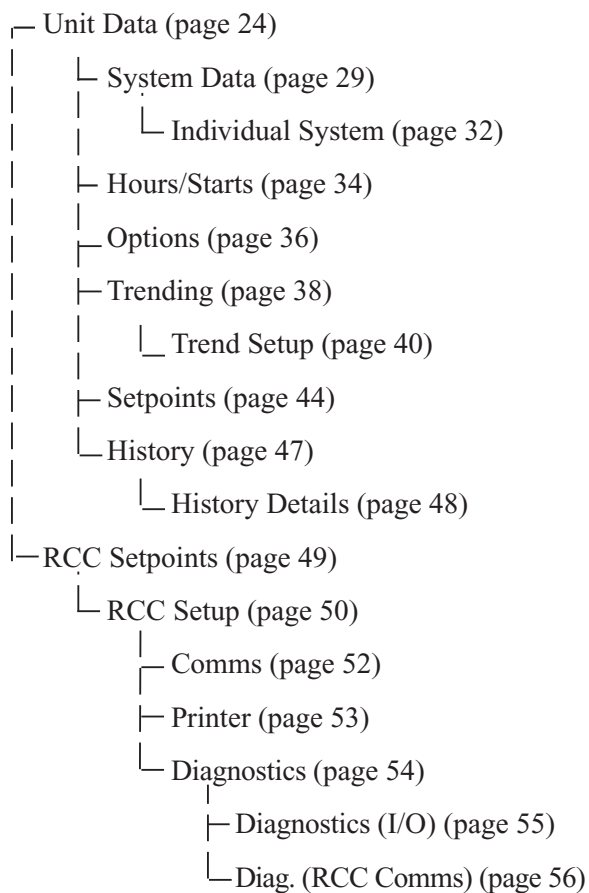

FIG. 8 – SCREEN NAVIGATION LAYOUT

This section of the manual will describe each screen in the order they are accessed as shown in this screen navigation layout.

This page intentionally left blank to maintain formatting

HOME SCREEN

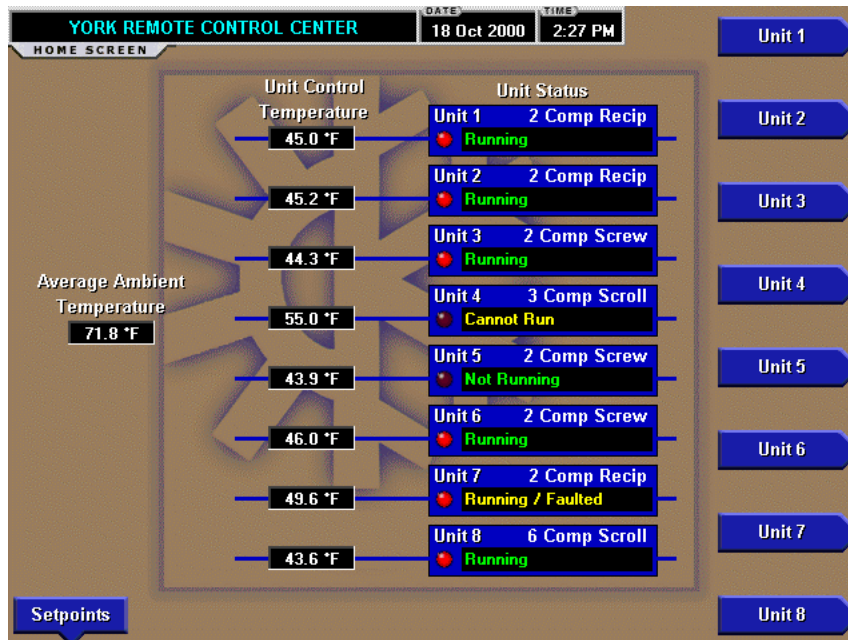

FIG. 9 – HOME SCREEN - EXAMPLE

00499VIPC

OVERVIEW

When the OptiView Remote Control Center is powered on, the above default display appears. This screen gives a general overview of the operating status of each unit connected to the OptiView Remote Control Center. The data and control of an individual unit is accessed from the Home Screen display. Fig. 9 is an example that shows eight units were programmed.

DISPLAY ONLY

Unit Control Temperature

Displays the temperature of what the unit is using for control such as leaving chilled liquid temperature. This is not shown if suction pressure is being used for control.

Unit Type

Displays the type of chiller the unit is.

Unit Status

Displays a general status message for the unit. The general status message will include communications status, running status, and fault status, etc. Following is a complete listing of the general status messages:

- **Not Initialized** will be displayed upon power-up for all units until the OptiView Remote Control Center begins to poll and receive data from that unit. While this message is displayed, the unit's button will be disabled, not allowing it to be selected.
- **Initializing...** will be displayed while the OptiView Remote Control Center is polling a unit for all current, schedule, and history data the first time after power-up. While this message is displayed, the unit's button will be disabled not allowing it to be selected.
- **Loss of Comms** will be displayed after 5 minutes have elapsed with no response from a previously initialized unit. While this message is displayed, the unit's button will be disabled not allowing it to be selected.
- **Running** will be displayed when at least 1 system is running on a unit with no faults on any system. This message will be displayed even if the chiller is in any kind of limiting as long as there are no faults present. While this message is displayed, the unit's button will be enabled allowing it to be selected.
- **Not Running** will be displayed when no systems on the unit are running for a non-fault reason but can run when demand requires. This would be for the No Cool Load state. While this message is displayed, the unit's button will be enabled allowing it to be selected.
- **Faulted** will be displayed when no systems on the unit are running and there is a fault on one or more systems or a unit fault. While this message

is displayed, the unit's button will be enabled allowing it to be selected.

- **Running / Faulted** will be displayed when at least one system on the unit is running and at least one system is faulted. While this message is displayed, the unit's button will be enabled allowing it to be selected.
- **Cannot Run** will be displayed for any non-fault condition preventing the entire chiller from running. This would include such things as the daily schedule, unit switch, all system switches, run perm, etc. While this message is displayed, the unit's button will be enabled allowing it to be selected.

Unit Run Indicator (LED)

Is **ON** when the unit is running.

Average Ambient Temperature

Displays the average Ambient Air Temperature of all the units connected.

PROGRAMMABLE

None

NAVIGATION

Unit #

A detailed view of data relevant to the specified (#) unit. If the "Not Initialized" status message is displayed, the unit's button will be disabled, not allowing it to be selected.

Setpoints

This screen provides the gateway to many of the OptiView Remote Control Center's general setup parameters such as Date/Time, Comm Setup, Printer Setup, etc.

UNIT SCREEN - EXAMPLES

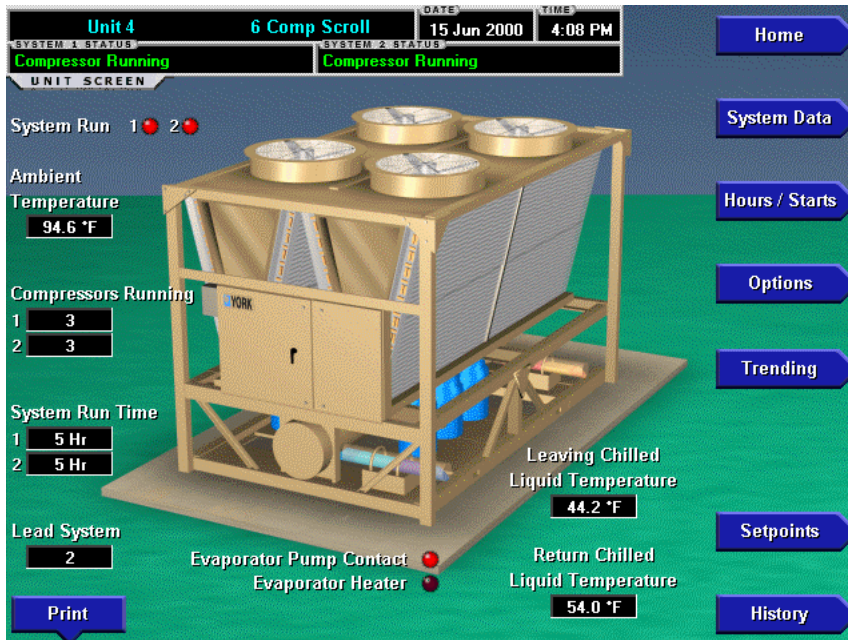

FIG. 10A – YCAL CHILLER

00569VIPC

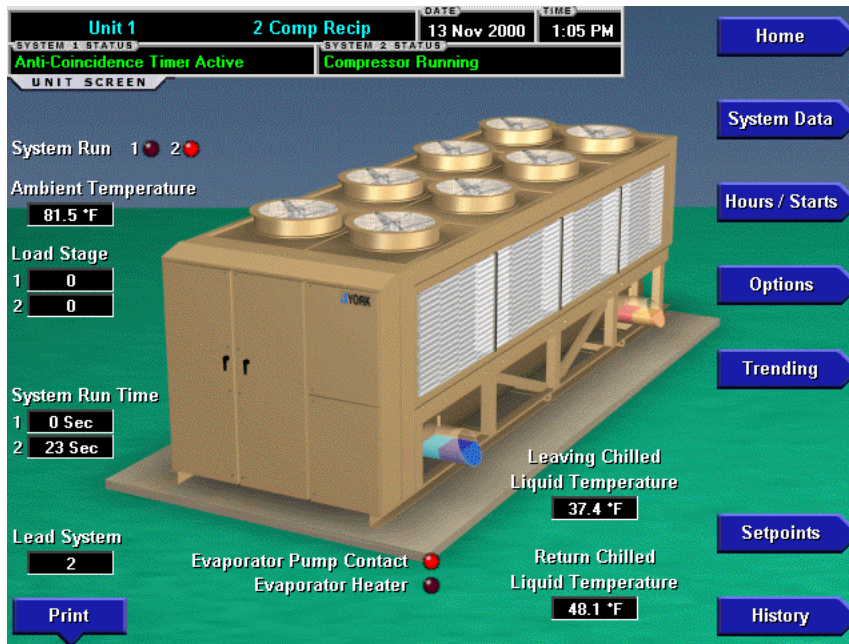

FIG. 10B – YCAR CHILLER

00570VIPC

UNIT SCREEN - EXAMPLES

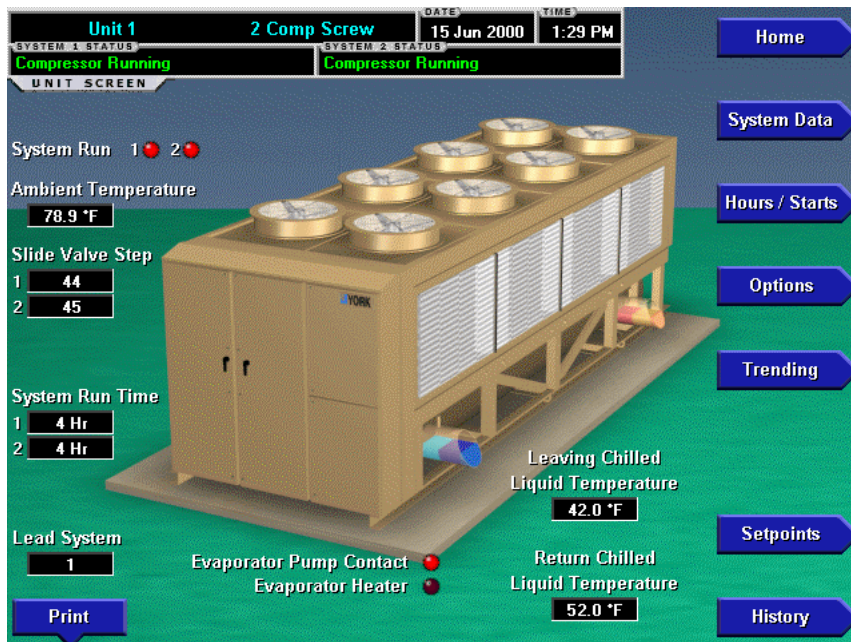

FIG. 10C – YCAS CHILLER

00571VIPC

3



FIG. 10D – YCUL CONDENSING UNIT

00572VIPC

UNIT SCREEN - EXAMPLES

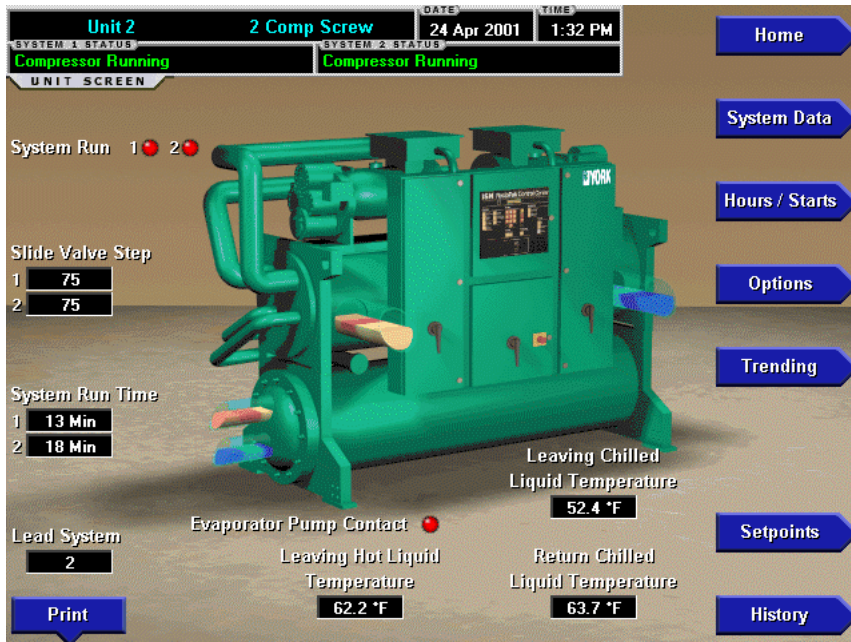

FIG. 10E – YCWS CHILLER

00573VIPC

UNIT SCREEN

OVERVIEW

This screen is accessed from the Home Screen. The primary values of the chiller or condensing unit which must be monitored and controlled are shown on this screen. The data available depends on the type of unit. This screen display depicts a visual representation of the unit itself. Animation indicates chilled liquid flow and condenser fans running.

DISPLAY ONLY

Systems Statuses

Displays the individual refrigerant systems operational statuses. The messages displayed include running status, cooling demand, fault status, external cycling device status, load limiting, and anti-recycle timer status. The status message that is displayed on the microprocessor is represented here.

System Run (LED)

Is **ON** when the individual refrigerant systems compressor is running. If any of these are **ON**, the fans will be animated to show that they are running.

Slide Valve Step (If Screw)

Displays the individual refrigerant systems slide valve step.

Load Stage (If Recip)

Indicates the number of solenoids on the compressor of a YCAR unit that are de-energized and loaded.

Number Of Compressors Running (If a system has more than one)

Displays how many compressors are running on the unit.

System Run Time

Displays the individual refrigerant systems logged run time since the last compressor start, in days (Days), hours (Hr), minutes (Min) or seconds (Sec).

Lead System

This message indicates which system is in the lead.

Evaporator Pump Contact (LED)

Is **ON** when the evaporator pump signal from the microprocessor is on. If this is **ON**, the chilled liquid will be animated to show that it is flowing.

Evaporator Heater (LED)

Is **ON** when the evaporator heater signal from the microprocessor is on.

Leaving Chilled Liquid Temperature

Displays the temperature of the liquid as it leaves the evaporator.

Return Chilled Liquid Temperature

Displays the temperature of the liquid as it enters the evaporator.

Discharge Air Temperature

Displays the discharge air temperature leaving the evaporator when the condensing unit is programmed for Discharge Air control.

Systems Suction Pressure

Displays the suction pressure for each individual system on a condensing unit when the unit was programmed for Suction Pressure control.

Ambient Temperature

Displays the outdoor Ambient Air Temperature.

PROGRAMMABLE

Print

Initiates a printout of current system operating parameters for the currently selected unit.

Cancel Print

Terminates the printing in process. This key is only visible while printing is in process.

NAVIGATION

Home

Causes an instant return to the Home Screen.

System Data

Used to provide additional system information.

Hours/Starts

This screen shows the cumulative operating hours and start count of each compressor.

Options

Used to provide information of the options that were programmed at the Unit Control Panel.

Trending

This screen provides the user a view of trending data on selected parameters of this chiller/condensing unit.

Setpoints

This screen provides a single location to program the unit setpoints for the selected unit.

History

This screen provides access to a snapshot of system data at each of the last 4-6 shutdown conditions.

This page intentionally left blank.

SYSTEMS SCREEN - EXAMPLES

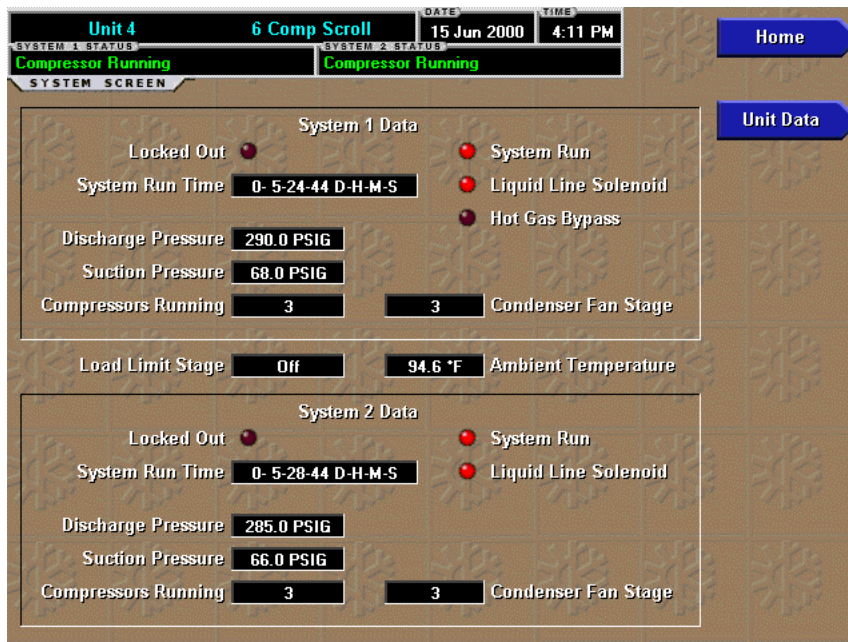

FIG. 11A – YCAL CHILLER

00505VIPC

3

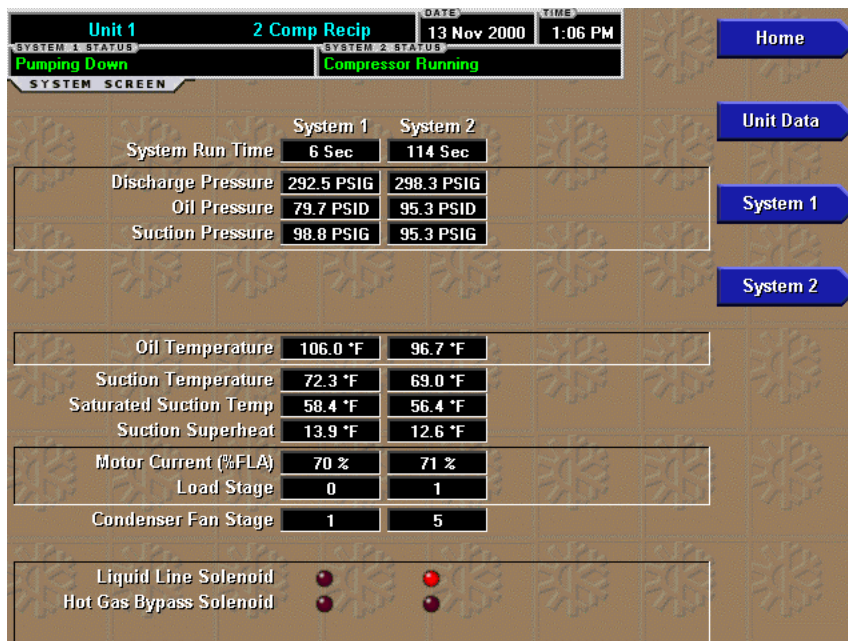

FIG. 11B – YCAR CHILLER

00506VIPC

SYSTEMS SCREEN - EXAMPLES

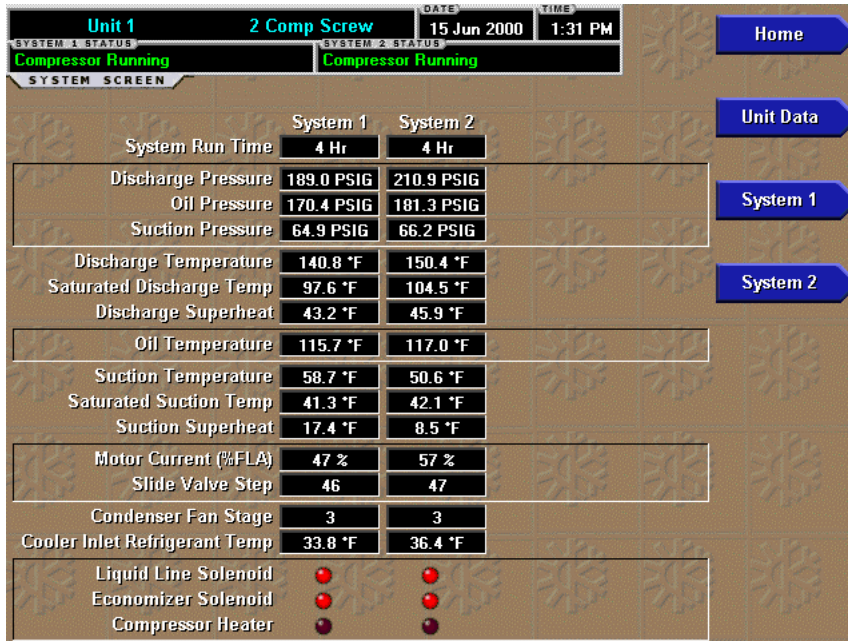

FIG. 11C – YCAS CHILLER

00507VIPC

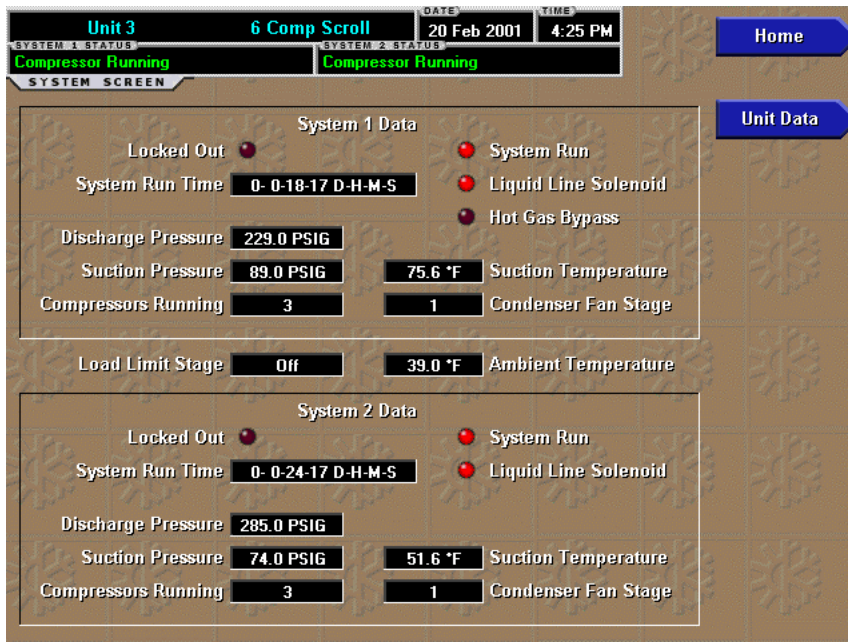

FIG. 11D – YCUL CONDENSING UNIT

00508VIPC

SYSTEMS SCREEN

OVERVIEW

This screen is accessed from the Unit Screen. A chiller can consist of separate refrigerant circuits. Each refrigerant circuit is referred to as a system. This screen shows system specific information for each of the unit's refrigerant systems. This information can vary according to the type of chiller. Reference the chiller's Installation, Operation, Maintenance Manual (IOM) for details.

DISPLAY ONLY

System Status

Displays this refrigerant systems operational status. The messages displayed include running status, cooling demand, fault status, external cycling device status, load limiting, and antirecycle timer status. The status message that is displayed on the Unit's microprocessor is represented here.

System Run (LED)

Displays this refrigerant systems operational status. Is **ON** when the system is running.

Locked Out (LED)

Is **ON** when a system is locked out on a fault requiring a manual reset at the chiller or condenser unit micro panel.

System Run Time

Displays the amount of time the system has run.

Temperatures and pressures are either measured directly by transducers and temperature sensors, or computed from these measurements. Depending on the type of chiller, the following temperatures and pressures could be displayed:

- Discharge Pressure
- Oil Pressure
- Suction Pressure
- Oil Temperature
- Discharge Temperature
- Suction Superheat
- Saturated Discharge Temperature
- Discharge Superheat
- Suction Temperature
- Saturated Suction Temperature

Motor Current (%FLA)

This displays the motor current of the system in percent of full load amps.

Slide Valve Step (If screw)

This indicates the compressor slide valve step.

Compressors Running

(If more than one compressor per circuit)

Indicates the number of compressors running

Load Limit Stage

Indicates which stage of Load Limiting a unit is in.

Load Stage

Indicates the number of solenoids on the compressor of a YCAR unit that are de-energized and loaded.

Condenser Fan Stage

Displays the stage of condenser fan operation on the system.

Cooler Inlet Refrigerant temperature (Only if in R-407c mode)

Displays the refrigerant temperature at the inlet of the cooler.

Liquid Line Solenoid (LED)

Is **ON** when the Liquid Line Solenoid Valve is energized/open.

Economizer Solenoid (LED)

Is **ON** when the economizer Thermal Expansion Valve Solenoid is energized/open.

Oil Cooling Solenoid (LED)

Is **ON** when the Oil Cooling Solenoid Valve is energized/open.

Compressor Heater (LED)

Is **ON** when the compressor heater is on.

Hot Gas Bypass (LED)

Is **ON** when the hot gas bypass valve is open.

PROGRAMMABLE

None

NAVIGATION

Home

Causes an instant return to the Home Screen.

Unit Data

Causes an instant return to the Unit Screen of the selected unit.

System #

A detailed view of the specified (#) system information.

INDIVIDUAL SYSTEM SCREEN

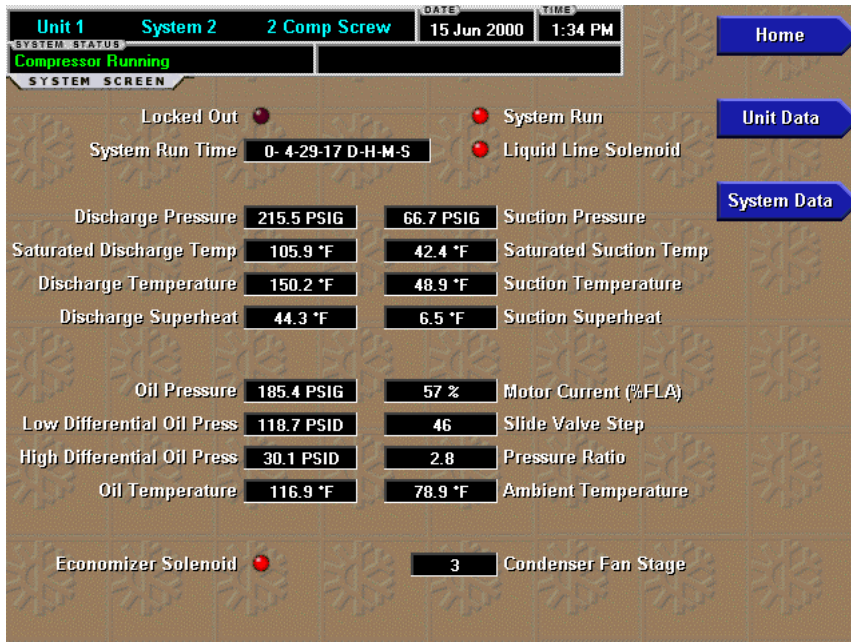

FIG. 12A – YCAS CHILLER

00509VIPC

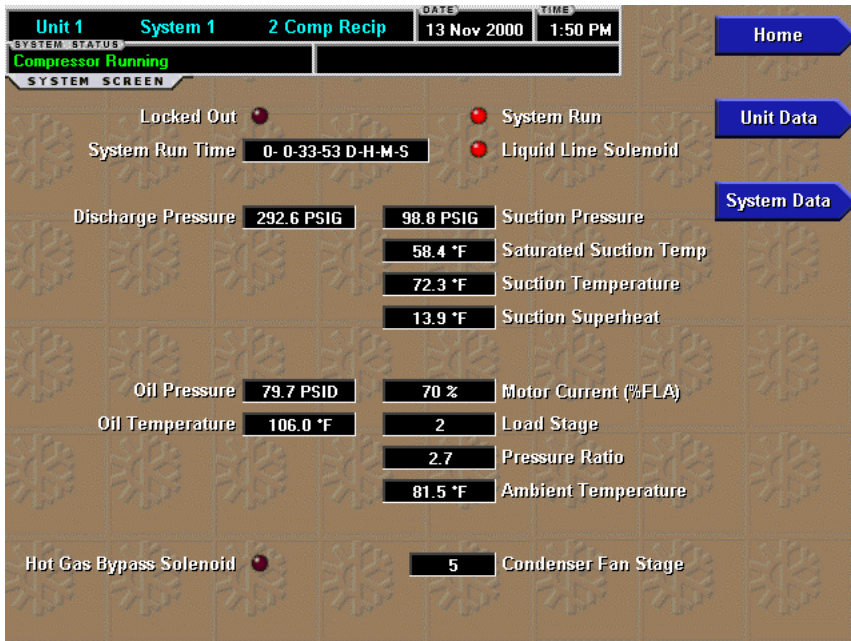

FIG. 12B – YCAR CHILLER

00510VIPC

OVERVIEW

This screen is accessible from the SYSTEM screen when there is much data to view about an individual system. It displays data only from the selected system. Reference the chiller's Installation, Operation, Maintenance Manual (IOM) for details about the data. Depending on the type of chiller, the following data might be displayed:

DISPLAY ONLY

The following system information is displayed at the top of the screen:

Locked Out (LED)s
System Run Time
System Run (LED)
Liquid Line Solenoid (LED)

The following discharge readings are grouped together and displayed:

Discharge Pressure
Saturated Discharge Temperature
Discharge Temperature
Discharge Superheat

The following suction readings are grouped together and displayed:

Suction Pressure
Saturated Suction Temperature
Suction Temperature
Suction Superheat

The following oil readings are grouped together and displayed:

Oil Pressure
Low Differential Oil Pressure
High Differential Oil Pressure
Oil Temperature

The following miscellaneous readings are grouped together and displayed:

Motor Current (%FLA)
Slide Valve Step or Load Stage
Pressure Ratio
Ambient Temperature

The following miscellaneous information is displayed separately:

Economizer Solenoid (LED)
Hot Gas Bypass Solenoid (LED)
Oil Cooling Solenoid (LED)
Condenser Fan Stage

PROGRAMMABLE

None

NAVIGATION**Home**

Causes an instant return to the Home Screen.

Unit Data

Causes an instant return to the Unit Screen.

System Data

Causes an instant return to the System Screen.

HOURS AND STARTS SCREEN

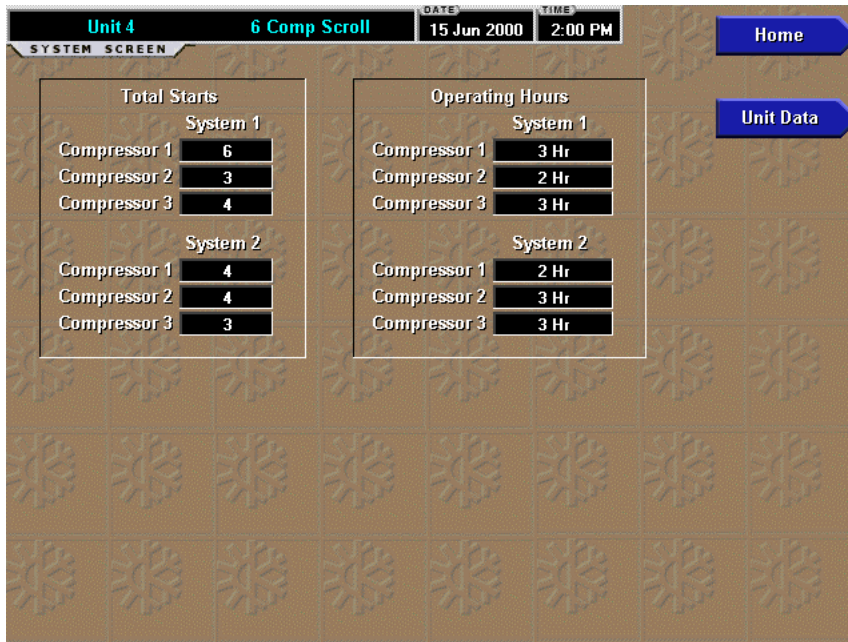

FIG. 13A – YCAL CHILLER

00511VIPC

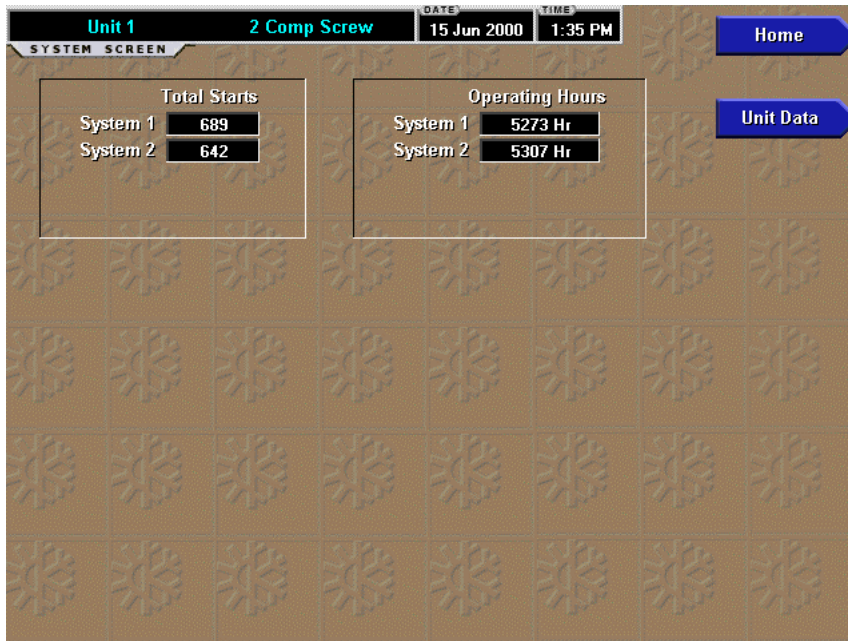

FIG. 13B – YCAS CHILLER

00512VIPC

OVERVIEW

This screen, accessed from the UNIT screen, displays the total operating hours and the total number of starts for all systems on the unit.

DISPLAY ONLY**Total Starts**

Displays the number of times the compressor has been started.

Operating Hours

Displays the number of hours the compressor has run.

PROGRAMMABLE

None

NAVIGATION**Home**

Causes an instant return to the Home Screen.

Unit Data

Causes an instant return to the Unit Screen.

OPTIONS SCREEN



FIG. 14A – YCAL CHILLER

00513VIPC



FIG. 14B – YCAS CHILLER / YCAR CHILLER

00514VIPC

OVERVIEW

This screen, accessed from the UNIT screen, displays all the dip switch settings and other programmable options at the chiller micro panel. These items can only be changed at the chiller micro panel and not at the OptiView Control Center. Depending on the type of chiller, the following data might be displayed:

DISPLAY ONLY

Units Display Mode

The units selected at the OptiView Remote Control Center, either **Imperial** or **SI**, is displayed. In Imperial Units temperatures will be in °F and pressures will be in PSIG or PSID. In SI units temperatures will be in °C and pressures will be in BARG or BARD.



The values at the OptiView Remote Control Center will be displayed in the units that are selected on it's Setpoints screen regardless of what is programmed at the chiller/condensing unit.

Refrigerant Type

The refrigerant, either **R-407C** or **R-22**, selected at the chiller micro panel is displayed.

Chilled Liquid Type

The cooling mode, either **Water** or **Glycol**, selected at the chiller micro panel is displayed.

Ambient Control Mode

The ambient mode, either **Standard** or **Low Ambient**, selected at the chiller micro panel is displayed.

Local/Remote Control Mode

The control mode selected at the chiller micro panel, either **Local** or **Remote**, is displayed.

Language Display Mode

The language selected at the chiller micro panel (i.e. **English**) is displayed.

Lead/Lag Control Mode

The Lead/Lag control at the chiller micro panel is displayed, either **Automatic** or **Manual**. This control is used to select which compressor starts. See the unit's Installation, Operation and Maintenance Manual for a description.

Fan Control Mode

The fan control at the unit's micro panel is displayed, either **Discharge Pressure** or **Ambient and Discharge Pressure**.

Unit Control Mode

What the chiller/condensing unit control is based on is displayed, either **Leaving Liquid**, **Return Liquid**, **Suction Pressure**, or **Discharge Air Temperature**.

Unit Software Version

The software version of the EPROMS at the chiller/condensing unit's micro panel .

PROGRAMMABLE

None

NAVIGATION

Home

Causes an instant return to the Home Screen.

Unit Data

Causes an instant return to the Unit Screen.

TRENDING SCREEN

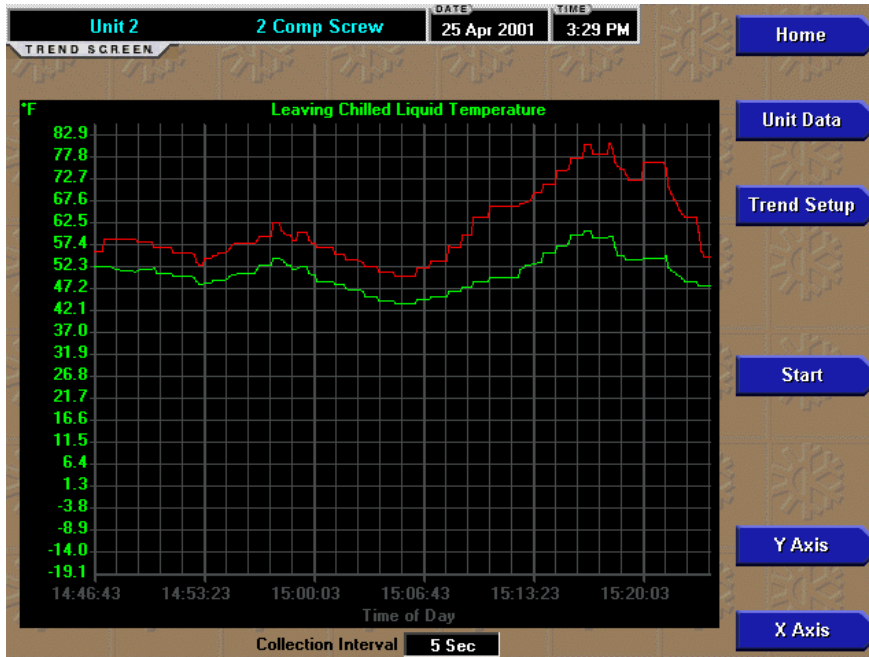

FIG. 15 TRENDING

00574VIPC

OVERVIEW

This screen is accessed from the UNIT screen. As many as six Operator selected parameters can be plotted in an X/Y graph format. The X-Axis is scaled per the selected Data Collection Interval and displayed in a time of day or elapsed time format, as selected with the X-axis toggle key. The Y-Axis is scaled for each parameter per the selected minimum and maximum value for each parameter. Analog parameters are scaled in pressure, temperature, volts, amps, hertz or time. Digital on/off parameters are scaled as zero (off) and one (on). Only one Y-Axis label is displayed at a time. The Y-Axis Toggle Key is used to toggle the Y-Axis labels through the different parameters. The Y-Axis label that is being displayed is identified at the top of the graph. All parameters are displayed simultaneously. For identification, each plotted parameter and associated Y-Axis labeling is color coordinated.

The parameters are sampled at the selected Data Collection Interval and plotted using 450 data points across the X-Axis. If the actual value of the sampled parameter is less than the Y-Axis label minimum for that parameter, the value will be plotted at the minimum value. Similarly, if the actual value is greater than the Y-Axis label maximum for that parameter, the value will be plotted at the maximum value.

There are two types of charts that can be created: ONE SCREEN or CONTINUOUS. When the plotting has reached the end of the X-Axis, one of the following will occur, depending on which is selected: If ONE SCREEN has been selected, the trending stops and the data is frozen. If CONTINUOUS has been selected, the oldest data is dropped from the left-hand side of the graph at the next Data Collection Interval. Thereafter, the oldest data is dropped from left-hand side of the graph at each Data Collection Interval.

Only parameters from the selected Unit are trended. The same parameters that have been selected for a Unit, will be selected by default for the next selected Unit. When on the Home screen, a Unit is not selected and any trending is stopped. Trending is also stopped if a power failure occurs while it is running. After trending is stopped, the last screen of data that was collected will be displayed on the trending screen and the START key must be pressed to initiate a new trend screen.

DISPLAY ONLY

This screen allows the user to view the graphical trending of the selected parameters and is also a gateway to the graph setup screens.

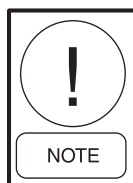

A red screen with the words “TREND MAX MUST BE > TREND MIN” will appear if the Y-Axis minimum has been programmed to a value that is greater than the Y-Axis maximum for any parameter. If this appears, proceed to the Trend Setup Screen to change the values.

PROGRAMMABLE

Start

Pressing this key clears the graph, starts a new graph and begins the trending. The trending will continue until the STOP key is pressed, the Home screen is displayed, or a power failure occurs. This key is only available if trending is stopped.

Stop

Pressing this key stops the trending. The trend data is frozen on the display until another graph is started with the START key. The Stop key is only available if trending is running.

Y-Axis

This key toggles the Y-Axis labels of the graph. Each key press changes the label to another of the selected parameters.

X-Axis

This key toggles the X-Axis labels of the graph. Each key press alternates the scaling between time of day and elapsed time. The Time of Day scaling is in 24-hour format. The Elapsed Time scaling is the time elapsed since the START key was pressed, starting the trending.

NAVIGATION

Home

Causes a return to the Home Screen.

Unit Data

Causes a return to the Unit Screen.

Trend Setup

Only displayed if the trending is stopped. Causes a jump to a sub-screen for configuring the trending display.

TREND SETUP SCREEN

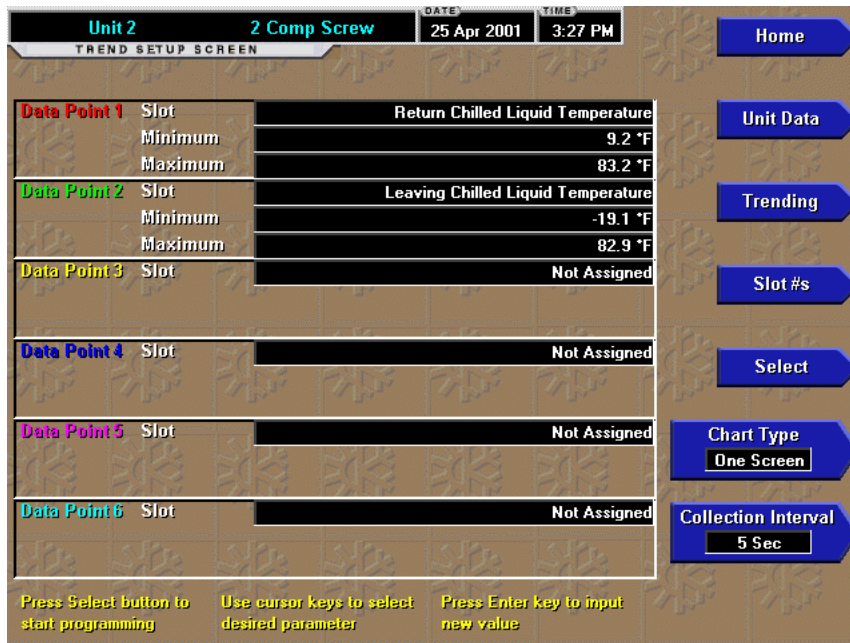

FIG. 16 TREND SETUP

OVERVIEW

This screen is accessed from the Trending screen. This screen is used to configure the trending screen. The parameters to be trended are selected from the Common Slots Screen or Common Slots Master list and entered as Slot Numbers for Data Points 1 through 6. The Y-Axis minimum and maximum values for each parameter are entered as Data Point Min and Data Point Max for Data Points 1 through 6. The interval at which all the parameters are sampled is selected as the Data Collection Interval.

DISPLAY ONLY

None

PROGRAMMABLE

Chart Type

Selects either CONTINUOUS or ONE SCREEN type of graph.

Collection Interval

Selects the interval at which the parameters are sampled. There are 450 data points displayed across the X-Axis of the graph. Each point represents the instantaneous value of the parameter. The user selects the time interval between these points. This is called the DATA

COLLECTION INTERVAL, or the interval at which the parameter is sampled. This interval is programmable over the range of 1 second to 3600 seconds (1 hour), in one second increments. The selected interval not only determines the sample interval, but also the full screen time display. The full screen time display is a result of the selected interval in seconds, multiplied by the 450 data points. For example, if the Data Collection Interval is programmed for 900 seconds, the parameter would be sampled every 900 seconds, with the last 112.5 hours (4.7 days) of data viewable on the screen. Therefore, the selected interval is a compromise between resolution and full screen time display. Select the desired Data Collection Interval as follows:

1. Determine the desired time interval (in seconds), between data samples.
2. Calculate the full screen time display as follows:
 - $450 \times \text{Data Collection Interval} = \text{full screen seconds}$
 - $\text{full screen seconds} / 60 = \text{full screen minutes}$
 - $\text{full screen minutes} / 60 = \text{full screen hours}$
 - $\text{full screen hours} / 24 = \text{full screen days}$
3. Decide if the resultant sample interval and full screen display meet the requirements. If not, select a different sample interval.

Select

This key is used to enter the slot numbers and the minimum and maximum Y-Axis values of each parameter to be trended. Pressing this key places a yellow box around Data Point 1 Slot Number. Use the ▲ and ▼ navigation keys to place the box around the value of Data Points 1 through 6 to be changed. With the desired value selected, press the ‘✓’ (Enter) key. A dialog box is displayed permitting data entry.

Data Point Slot # (1-6)

Use the SELECT key as described above and enter the slot number from the Trend Common Slots Screen of the desired parameter to be trended. The selected parameter description will be displayed for the Data Point. Setting this slot number to zero will disable trending for that particular Data Point. Any or all points can be disabled.

Data Point Min (1-6)

Only displayed if the Associated Slot Number is not Zero. This is the minimum value displayed for the Y-Axis. Selecting a parameter for a Data Point sets this to the default value, which is the lowest value allowed for that parameter. It can be changed to a value that provides a more appropriate resolution for the parameter being monitored. To change, use the SELECT key as described above and enter the desired value. The value must always be set to a value less than the Data Point Max. Otherwise, a red graph is displayed on the Trend Screen with the words “TREND MAX MUST BE > TREND MIN”. If the parameter selected for this data point is a digital type (on/off), this value must be set to zero (0). Zero indicates the OFF state.

Data Point Max (1-6)

Only displayed if the associated slot number is not zero. This is the maximum value displayed for the Y-Axis. Selecting a parameter for a Data Point sets this to the default value, which is the highest value allowed for that parameter. It can be changed to a value that provides a more appropriate resolution for the parameter being monitored. To change, use the SELECT key as described above and enter the desired value. The value must always be set to a value greater than the Data Point Min. Otherwise, a red graph is displayed on the Trend Screen with the words “TREND MAX MUST BE > TREND MIN”. There are 20 Y-axis divisions. If a MIN-MAX span is selected that is not evenly divided by 20, the Program will automatically select the next higher MAX value that makes the span evenly divided by 20. For example, if 0.0 is selected as the MIN, and 69.0 as the MAX, the Program will insert 70.0 as the MAX value. If the parameter selected for this data point is a digital type (on/off), this value must be set to one (1). One indicates the on state.

NAVIGATION**Home**

Causes a return to the Home Screen.

Unit Data

Causes a return to the Unit Screen.

Trending

Causes a return to the Trending Screen.

Slot Numbers

Causes a jump to the Trend Common Slots Screen. The slot numbers of the most commonly monitored parameters are listed on this screen. The parameters are arranged to make it easier to find the slot number of the desired parameter to plot.

This page intentionally left blank.

This page intentionally left blank.

SETPOINTS SCREEN - EXAMPLES

Unit 4 6 Comp Scroll DATE: 15 Jun 2000 TIME: 2:03 PM

SETPOINTS SCREEN Home

Leaving Chilled Liquid Temperature
 Setpoint **44.0 °F**
 Control Range **2.0 °F (+/-)**

Remote Chiller Run
 Run

Unit Data

Load Limit Setpoint **Off** Remote Chiller Run

Daily Schedule	Start Time	Stop Time	Holiday?
Monday	12:00 AM	12:00 AM	No
Tuesday	12:00 AM	12:00 AM	No
Wednesday	12:00 AM	12:00 AM	No
Thursday	12:00 AM	12:00 AM	No
Friday	12:00 AM	12:00 AM	No
Saturday	12:00 AM	12:00 AM	No
Sunday	12:00 AM	12:00 AM	No
Holiday	12:00 AM	12:00 AM	No

Load Limit Setpoint Change Schedule

Repeat Monday

Clear Schedule

Leaving Chilled Liquid Temperature
 Setpoint Range

FIG. 17A – YCAL CHILLER

00515VIPC

Unit 1 2 Comp Screw DATE: 15 Jun 2000 TIME: 1:38 PM

SETPOINTS SCREEN Home

Leaving Chilled Liquid Temperature
 Setpoint **42.0 °F**
 Control Range **1.5 °F (+/-)**

Remote Chiller Run
 Run

Unit Data

Current Limit Setpoint **100 %** Remote Chiller Run

Daily Schedule	Start Time	Stop Time	Holiday?
Monday	12:00 AM	12:00 AM	No
Tuesday	12:00 AM	12:00 AM	No
Wednesday	12:00 AM	12:00 AM	No
Thursday	12:00 AM	12:00 AM	No
Friday	12:00 AM	12:00 AM	No
Saturday	12:00 AM	12:00 AM	No
Sunday	12:00 AM	12:00 AM	No
Holiday	12:00 AM	12:00 AM	No

Current Limit Setpoint Change Schedule

Repeat Monday

Clear Schedule

Leaving Chilled Liquid Temperature
 Setpoint Range

FIG. 17B – YCAS CHILLER

00516VIPC

Unit 1
2 Comp Recip

DATE

TIME

13 Nov 2000
2:04 PM

Home

SETPOINTS SCREEN

Leaving Chilled Liquid Temperature

Setpoint 35.0 °F

Control Range 2.0 °F (+/-)

Current Limit Setpoint

105 %

Remote Chiller Run

Run

Remote Chiller Run

Run

Daily Schedule	Start Time	Stop Time	Holiday?
Monday	7:00 AM	5:00 AM	No
Tuesday	7:00 AM	5:00 AM	No
Wednesday	7:00 AM	5:00 AM	No
Thursday	7:00 AM	5:00 AM	No
Friday	7:00 AM	5:00 AM	No
Saturday	7:00 AM	2:00 AM	No
Sunday	7:00 AM	5:00 AM	No
Holiday	12:00 AM	12:00 AM	No

Current Limit Setpoint

105 %

Change Schedule

Change Schedule

Repeat Monday

Repeat Monday

Clear Schedule

Clear Schedule

Leaving Chilled Liquid Temperature

Setpoint
Range

FIG. 17C – YCAR CHILLER

00517VIPC

SETPOINTS SCREEN

OVERVIEW

This screen, accessed from the Unit screen, provides a convenient location for programming the most common setpoints involved in the chiller/condensing unit control. The setpoints depend on the type of unit.



Values on this screen are only programmable if the chiller/condensing unit is in remote control mode. These values are only viewable if the unit is in local mode.

DISPLAY ONLY

None

PROGRAMMABLE

Leaving Chilled Liquid Temperature or Return Chilled Liquid Temperature or Suction Pressure or Discharge Air Temperature Setpoint

This value allows the user to define the cooling setpoint that is to be maintained by the chiller/condensing unit. See the unit's Installation, Operation and Maintenance Manual (IOM) for its programmable range.

Leaving Chilled Liquid Temperature or Return Chilled Liquid Temperature or Suction Pressure or Discharge Air Temperature - Control Range

This is the maximum allowable positive and negative deviation that is acceptable from setpoint in the system application. See the unit's Installation, Operation and Maintenance Manual (IOM) for its programmable range.

Remote Chiller Run or Remote Unit Run

The chiller/condensing unit can be selected to either **Run** or **Stop**. Selecting **Stop** will command the chiller/condensing unit to shut down. Selecting **Run** will allow the chiller/condensing unit to turn on.

Current Limit Setpoint

This is the motor current limiting setpoint. The chiller will be limited from loading when the motor current equals or exceeds this value. Typically, for most installations, no limiting is required and the programmed limiting will be set at or above 100%.

Load Limit Setpoint (YCAL Chillers)

Load Limiting can be programmed from 0 to 2.

Load Limit 0 = no load limit

Load Limit 1 = 50% load limit - 2/4 compressor units.

Load Limit 1 = 66% load limit - 3/6 compressor units.

Load Limit 2 = 33 % - 3/6 compressor units only.

Change Schedule

The daily schedule is a 1 week schedule and must be programmed for the start and stop time for each week day and a holiday if desired. A box is provided to specify which days are to use the holiday schedule.



Programming the same time for both Start and Stop times will cause the display to enter 00.00 for both times which will cause the chiller to always be allowed to run.

Repeat Monday

The other days can be selected to change to the Monday schedule.

Clear Schedule

In a situation where it is required to run the chiller 24 hours a day, 7 days a week, the Chiller Control panel should first have its entire Daily Schedule zeroed (00.00) for all Start and Stop times. This puts the chiller in the run mode at all times. The OptiView Remote Control Center may now be programmed with all zeroes (00.00) for all Start and Stop times by pressing the **Clear Schedule** button. Since the chiller panel is already in the run mode, programming the OptiView Remote Control Center for all zeroes will keep the chiller in this mode indefinitely, allowing the chiller to run whenever demand requires.

NAVIGATION

Home

Causes an instant return to the Home Screen.

Unit Data

Causes an instant return to the Unit Screen.

HISTORY SCREEN



FIG. 18

00518VIPC

3

OVERVIEW

This screen allows the user to browse through the faults. In order to get a more thorough reporting of the system conditions at the time of the recorded shutdown, move to the sub-screen **HISTORY DETAILS**.

The user may use the **Select Fault** button to select the history to view. At this point the **View Details** button is used to jump to a sub-screen containing stored chiller parameters values at the time of the shutdown. Additionally, the **Print History** button can be used to generate a hard-copy report of the parameter values at the time of the shutdown.

DISPLAY ONLY

Last Faults

This window displays a chronological listing (most recent first) of the date and time and the description of the last four to six safety shutdowns (depending upon the type of chiller) that occurred while the system was running.

PROGRAMMABLE

Print History

This generates a report listing the status of the chiller parameters at the time of the selected shutdown.

Print All Histories

This generates a report listing the status of the chiller parameters at the time of each of the stored shutdowns.

Cancel Print

Terminates the printing in process. This key is only visible while printing is in process.

NAVIGATION

Home

Causes an instant return to the Home Screen.

Unit Data

Causes an instant return to the Unit Screen.

View Details

Causes a move to a sub-screen containing the value of select chiller parameters at the time of the associated shutdown.

HISTORY DETAILS SCREEN



FIG. 19

00519VIPC

OVERVIEW

This screen allows the user to see an on-screen printout of all the system parameters at the time of the selected shutdown. Not all screens are shown above. The number of screens required to display all of the data varies according to the type of unit selected.

DISPLAY ONLY

History Printout

This is the on-screen printout of the system parameters.

PROGRAMMABLE

Page Up

Scroll up in the displayed data (if applicable).

Page Down

Scroll down in the displayed data (if applicable).

NAVIGATION

Home

Causes an instant return to the Home Screen.

Unit Data

Causes an instant return to the Unit Screen.

History

Causes a return to the History Screen.

RCC SETPOINTS SCREEN

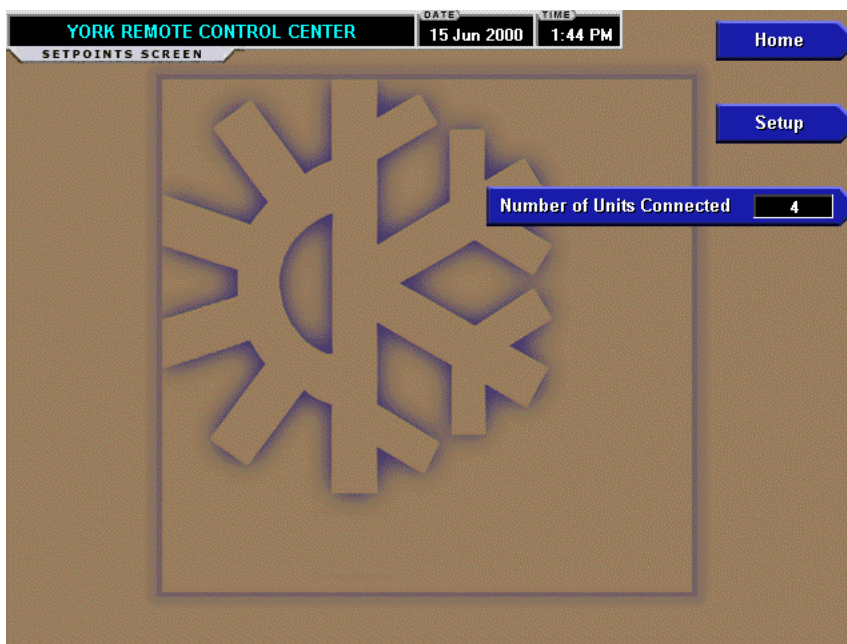

FIG. 20

00520VIPC

3

OVERVIEW

This screen is accessed from the Home Screen. This screen shows configuration parameters for this OptiView Remote Control Center. This screen also serves as a gateway to more sub-screens for defining general system parameters.

DISPLAY ONLY

None

PROGRAMMABLE

Number of Units Connected

Allows the user to program how many units the Control Center will need to communicate to.

NAVIGATION

Home

Causes an instant return to the Home Screen.

Setup

This screen provides a single location to program the general system setup parameters such as Date/Time. It is also the gateway to many of the general system setup parameters such as Communications, Printer Setup, etc.

RCC SETUP SCREEN



FIG. 21

00521VIPC

OVERVIEW

This screen is accessed from the RCC Setpoint Screen. This screen shows the general configuration parameters for this OptiView Remote Control Center. It allows programming of the time and date, along with specifications as to how the time will be displayed (12 or 24 hour format). This time is used for display purposes on the OptiView Remote Control Center. It is not used to reset individual chiller clocks and has no effect on individual chiller schedules. This screen also serves as a gateway to more sub-screens for defining general RCC system parameters.

DISPLAY ONLY

None

PROGRAMMABLE

Clock (Enabled / Disabled)

Allows the user to enable or disable the real-time clock in order to conserve battery life. The clock will be disabled during manufacturing and must be enabled at system commissioning. In addition, when preparing for prolonged shutdown the clock should once again be disabled.

Set Date

Allows the user to specify the present date. When prompted to enter a date value, the user must enter the day, month, and four-digit year (using leading zeroes as necessary). If within range, the value will be accepted. If out of range, the user is prompted for the information again. At this point the user may retry the date entry, or cancel the programming attempt.

Set Time

Allows the user to specify the present time. When prompted to enter a time value, the user must enter the hour and minute desired (using leading zeroes as necessary). If the chiller is presently set to 24-hour mode, the time must be entered in the 24-hour format. Otherwise, the user must also select AM or PM for the entered time. If out of range, the user is prompted for the information again. At this point the user may retry the time entry, or cancel the programming attempt.

12/24 Hr

Allows the user to specify the format in which the time will be presented to the user. This setpoint will only affect the display of the time on the OptiView RCC panel and on all reports generated. 12-Hour time format will include the **AM** and **PM** modifiers and show the range of time between 1:00 and 12:59, while the 24-Hour time format will show the range of time between 0:00 and 23:59.

Units

Define the unit system (Imperial or SI) used by the OptiView RCC display. This selection has no effect on the chiller/condensing unit micro panel.

NAVIGATION**Home**

Causes an instant return to the Home Screen.

Setpoints

Causes a return to the Setpoints Screen.

Comms

Moves to the sub-screen allowing configuration of system communications.

Printer

Moves to the sub-screen allowing configuration and control of printer functions.

Diagnostics

Moves to the sub-screen allowing limited diagnostic capability while operating.

COMMS SCREEN

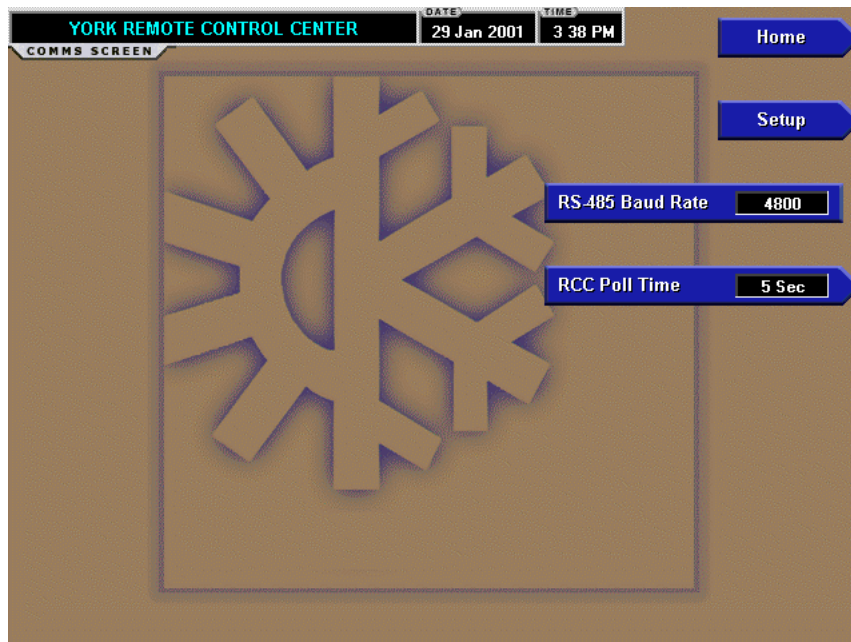

FIG. 22

00522VIPC

OVERVIEW

This screen is accessed from the RCC Setup Screen. This screen allows definition of the necessary communications parameters. Refer to PRINTER Section of this book for details of the Printer connections and setup.

DISPLAY ONLY**RS-485 Baud Rate 4800**

Shows the baud rate at which the panel shall communicate through the Com3 port to the remote control panel(s). The baud rate of the remote control panel(s) must be set for 4800 in the EPROM. Make sure the correct EPROM is installed at the chiller/condenser control panel(s). See Table 1.

PROGRAMMABLE**RCC Poll Time (5-30 sec.)**

Define the poll time (how frequently) this panel requests for data from another panel through the Com3 port.

NAVIGATION**Home**

Causes an instant return to the Home Screen.

Setup

Return to the Setup Screen.

PRINTER SCREEN

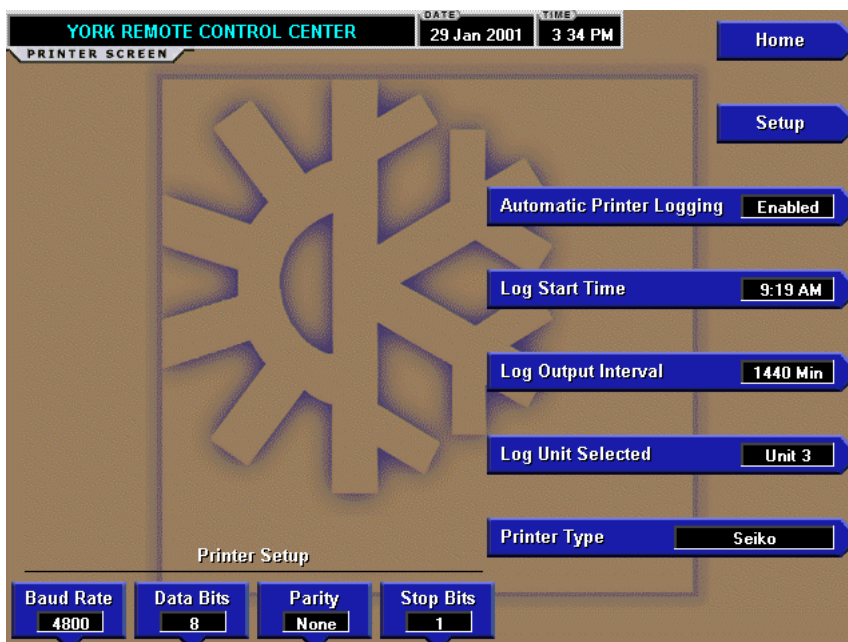

FIG. 23

00523VIPC

3

OVERVIEW

This screen is accessed from the RCC Setup Screen. This screen allows definition of the necessary communications parameters for the printer. Refer to PRINTER section of this book for details of the Printer connections and setup.

DISPLAY ONLY

None.

PROGRAMMABLE

Automatic Printer Logging (Enabled / Disabled)

Enable the printer to begin printing status reports beginning at the programmed start time and recurring at the interval defined above.

Log Start Time

Set the time at which scheduled logs will begin.

Log Output Interval

Define the interval at which logging will occur. We suggest you select a reasonable amount of time so that it is not occurring too much.

Log Unit Selected

Select a unit or all units to logs of.

Printer Type

Define the printer type connected to the OptiView RCC.

Printer Baud Rate

Define the baud rate at which the panel shall communicate to the printer.

Printer Data Bit(s)

Define the number of data bits with which the panel shall communicate to the printer.

Printer Parity Bit(s)

Define the number of parity bits with which the panel shall communicate to the printer.

Printer Stop Bit(s)

Define the number of stop bits with which the panel shall communicate to the printer.

Cancel Print

Terminates the printing in process. This key is only visible while printing is in process.

NAVIGATION

Home

Causes an instant return to the Home Screen.

Setup

Return to the Setup Screen.

DIAGNOSTICS SCREEN

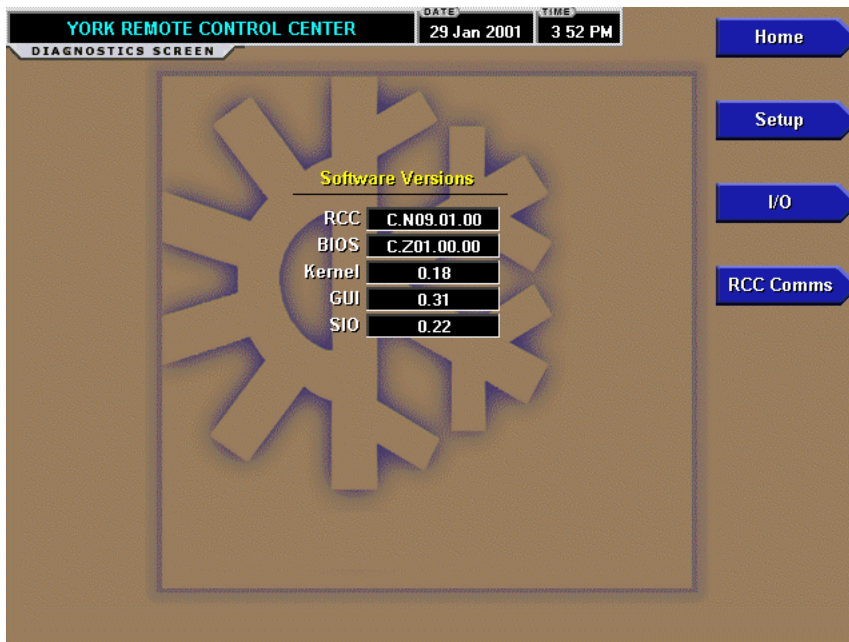

FIG. 24

00524VIPC

OVERVIEW

This screen is accessed from the RCC Setup Screen. This screen provides a view of what software is in use and provides access to a screen for troubleshooting analog and digital inputs.

DISPLAY ONLY

Software Versions

The following software versions are displayed:

- RCC - FLASH Memory Card on Microboard
- BIOS - BIOS EPROM on Microboard
- Kernel - Software that is part of FLASH Memory Card
- GUI - Software that is part of FLASH Memory Card
- SIO - Software that is part of FLASH Memory Card

PROGRAMMABLE

None

NAVIGATION

Home

Causes an instant return to the Home Screen.

Setup

Return to the Setup Screen.

I/O

Moves to the sub-screen allowing diagnostics of the analog and digital inputs.

RCC Comms

Moves to the sub-screen allowing diagnostics of communications with the RCC.

DIAGNOSTICS I/O SCREEN

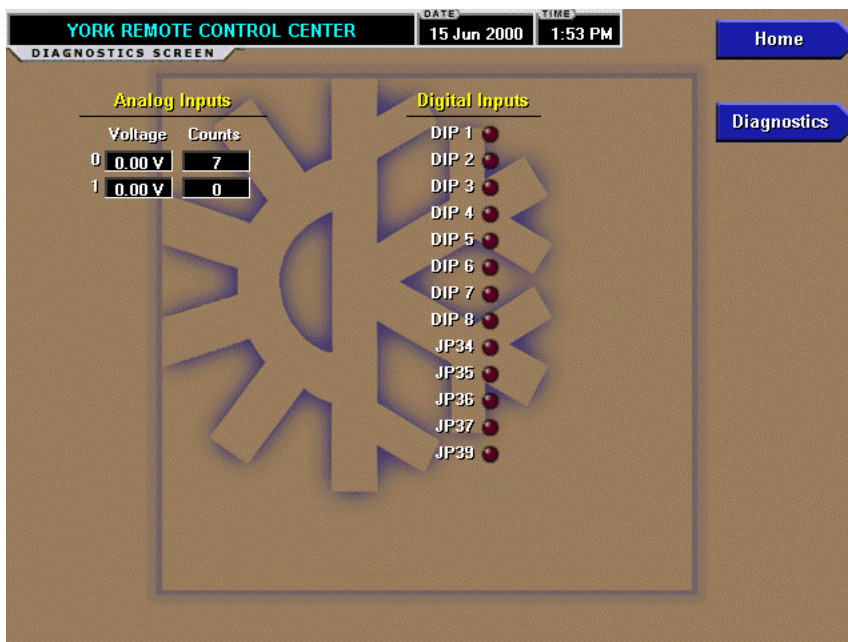

FIG. 25

00525VIPC

3

OVERVIEW

This screen is accessed from the Diagnostics Screen. This screen provides a view of the analog and digital inputs for troubleshooting .

DISPLAY ONLY

Diagnostics is used to analyze the Analog Inputs at the Microboard. The voltage level of each Analog Input, as interpreted by the Microboard, is displayed. “Counts” is an Analog-to-Digital (A/D) converter value and is for manufacturing and engineering use only.

Diagnostics is also used to analyze the state of each Microboard Program Jumper and Program DIP Switch as interpreted by the Microboard. These are depicted by an LED.

PROCEDURE

Digital Inputs:

1. The Digital Inputs are listed on this screen according to a.) Microboard Program Jumpers and Program DIP Switches. Tables 2 and 3 list the functions of the Program Jumpers and Switches.

2. If a Program Jumper is present, the applicable LED should be extinguished. If the LED is not extinguished, the Microboard is defective.
3. If a Program Jumper is not present, the applicable LED should be illuminated. If the LED is not illuminated, the Microboard is defective.
4. If a Program Switch (DIP) is in the ON position, the applicable LED should be illuminated. If the LED is not illuminated, the Microboard is defective.
5. If the Program Switch (DIP) is in the OFF position, the applicable LED should be extinguished. If the LED is not extinguished, the Microboard is defective.
6. When all desired tests have been performed, press DIAGNOSTICS key to return to MAIN DIAGNOSTICS Screen.

PROGRAMMABLE

None

NAVIGATION

Home

Causes an instant return to the Home Screen.

Diagnostics

Causes a return to the previous screen.

DIAGNOSTICS RCC COMMS SCREEN

Unit	Unit Type	Poll	Reply	Poll Count	Reply Count	Bad Csum Count	Timeout Count
Unit 1	2 Comp Screw	●	●	3513	3513	0	0
Unit 2	2 Comp Recip	●	●	6462	6462	0	0
Unit 3	2 Comp Scroll	●	●	4055	4055	0	0
Unit 4		●	●	0	0	0	0
Unit 5		●	●	0	0	0	0
Unit 6		●	●	0	0	0	0
Unit 7		●	●	0	0	0	0
Unit 8		●	●	0	0	0	0

FIG. 26

00526VIPC

OVERVIEW

This screen is accessed from the Diagnostics Screen. This screen provides a view of communication for troubleshooting .

Communication between the OptiView RCC and the chiller/condenser control panel(s) should consist of the RCC polling (requesting a response from) each chiller/condenser control panel starting with Unit 1 and continuing to Unit “x”, where “x” is the Number of Units Connected as entered on the RCC Setpoints Screen. Each poll will increment the **Poll Count**. A reply should be sent back to the RCC from the Unit that was polled within a certain amount of time. If this reply does not happen within this time period the **Timeout Count** will be incremented. If the reply is returned but contains improper data, then the **Bad Csum Count** will be incremented. If the reply is successfully received by the RCC then the **Reply Count** is incremented.

Good communication is indicated by the **Poll Count** and the **Reply Count** keeping close to the same count. A high **Timeout Count** could imply that the chiller/condenser control panel did not properly receive the request or it did not properly send a response. Check the wiring and the Installation Checklist. A high **Bad Csum Count** could be indicative of noise being transmitted. This can happen because of improper wiring or grounding.

DISPLAY ONLY

Unit Type

Displays the chiller type, whether it is a “Screw”, “Recip”, or “Scroll” and the number of compressors for the “Unit x”, where x is the number of the unit.

Poll Indicator (LED)

Is on when the last noted communication through the Com3 port was to poll a chiller/condenser control panel.

Reply Indicator (LED)

Is on when the last noted communication through the Com3 port was to receive a reply from a chiller/condenser control panel.

Poll Count

A count of each poll request through the Com3 port to a chiller/condenser control panel.

Reply Count

A count of each reply successfully received through the Com3 port from a chiller/condenser control panel.

Bad Csum Count

A count of each reply received through the Com3 port from a chiller/condenser control panel that had a bad Csum calculation. This indicates that improper data was received.

Timeout Count

A count of each poll request through the Com3 port to a chiller/condenser control panel that did not get a reply within the timeout period (time to wait for a reply).

PROGRAMMABLE**Clear Counters**

Resets all the counts to zero.

NAVIGATION**Home**

Causes an instant return to the Home Screen.

Diagnostics

Causes a return to the previous screen.

DISPLAY MESSAGES

A title bar will be displayed on all screens. This title bar will contain the OptiView Remote Control Center date and time on all RCC screens. This title bar will contain the Chiller/Condensing unit's date and time on all unit screens. On the Home Screen the message will read "YORK REMOTE CONTROL CENTER". On all other screens it will contain the unit selected and either the chiller type or will be based on the number of compressors of that unit.

When a unit has been selected the title bar will display a dual message on every screen. The first message will display the Unit Selected in the format "Unit x", where x is the number (1 – 8) of the unit selected. The second message will display the chiller type, whether it is a "Screw", "Recip" or "Scroll" and the number of compressors.

On the Unit Screen and all System Screens the title bar contains another message called a Status. The current status of each unit is displayed in this message. These messages will include running status, cooling demand, fault status, external cycling device status, load limiting and anti-recycle timer status, etc. A System Status message and a Unit Status message are never displayed simultaneously. A single message is displayed for a Unit Status message, while a separate System Status message will display for each system on multi-circuit units.

Status messages fall into the categories of warning, safety, and normal with each of the categories discussed following:

- **Warning** messages are denoted by yellow message text. A warning message is shown for any special running condition and for all unit warnings. Any kind of load limiting would be an example of a warning message. An incorrect refrigerant programmed warning would also be an example of a warning message.
- **Safety** messages are denoted by red message text. A safety message is shown for any type of safety shutdown, lock-out, or run inhibit. High discharge pressure would be an example of a safety shutdown message.
- **Normal** messages are denoted by green text. A normal message is shown for any non-fault normal condition. The compressor running and no cooling load messages would be examples of normal messages.

Note that there are two types of shutdowns. If the chiller shuts down on a SAFETY shutdown, it requires the operator to perform a manual reset at the keypad. A NORMAL shutdown occurs from a properly requested or scheduled shutdown. The event that caused the shutdown is displayed on the Status Line.

STATUS MESSAGES

Status messages will be much like those displayed at the chiller panel. Explanation of these displays will be outlined in the Installation Manual for each specific chiller. Subtle differences may be noted in the exact wording displayed versus the display which is shown on the chiller panel. An example of this is apparent in the anti-recycle and anti-coincidence timers. In the case of these messages, the chiller control panel indicates actual time left on the timers. The OptiView Remote Control Center will only indicate that the timers are "Active".

The new message "Loss of Communications" indicates that the communications link between the chiller control panel and the OptiView Remote Control Center has been lost. This loss of communications is normally a result of disconnecting the RS-485 communications cable between the two panels or the loss of power to the chiller control panel.

If communications is lost and not re-established, local chiller setpoints will command chiller control after 5 minutes.

In addition to the chiller status messages there are the Optiview Remote Control Center general status messages that are displayed on a single line on the Home Screen for each chiller. See the description of the Home Screen in this manual.

SAFETY SHUTDOWN MESSAGE

"WATCHDOG – SOFTWARE REBOOT"

The Microboard's software Watchdog initiated a Microprocessor reset because it detected that a portion of the chiller operating Program was not being executed. The result of this reset is a Safety shutdown and re-initialization of the Program. This is generally indicative of a severe electrical power disturbance or impending Microboard Failure. The chiller can be started after the COMPRESSOR switch is placed in the Stop-Reset (O) position.

SECTION 4 – PRINTERS



23887A

OKIDATA MICROLINE 184



23889A

WEIGH-TRONIX



00085VIP

SEIKO DPU-414

FIG. 27 – PRINTERS

PRINTERS

A printer can be connected to the OptiView Remote Control Center's Microboard to print the following reports. The screen from which each report can be generated is listed in parenthesis.

- **Operating Data** - Present system parameters (Unit)
- **History** - System parameters at the time of the last fault while running and last saved faults (History)

The printer can be permanently connected to the Remote Control Center or connected as required to produce a report. If permanently connected, a **DATA LOGGING** feature can produce a Status report automatically, beginning at an Operator selected start time and occurring at an Operator selected interval thereafter.

The following figures are examples of the different print reports.

- Figure 28 - Operating Data
- Figure 29 - History (Header)

PRINTERS

The following Printers can be used. **Printers must be equipped with an RS-232 Serial interface.**

- **Okidata** –
Models: 182,182 turbo, 184 turbo
Dimensions: 14 in. wide x 10.5 in. deep
Paper: 8.5 in. wide
Type: Dot matrix impact
- **Weigh-Tronix** –
Models: 2600, 1220
Dimensions: 2.3 in. wide x 2.8 in. deep
Paper: 2.25 in. wide
Type: Dot matrix impact
- **Seiko** –
Model: DPU414-30B (Power supply PW4007-U I required)
Dimensions: 6.3 in. wide x 6.7 in. deep
Paper: 4.4 in. wide
Type: Thermal

Purchase: Contact your local
YORK Service Office

The OptiView Remote Control Center provides the required formatting control codes for the printers above

when the printer is selected on the PRINTER Screen in the instructions below. These codes are transmitted through the serial interface to the printer to provide a proper print format. Different printers require different formatting control codes. Other printers might provide proper operation when connected to the OptiView Remote Control Center. However, the print format may not be correct or as desired. Proceed with caution and use the following guidelines if an unlisted printer is selected:

1. All must be capable of RS-232 Serial communications.
2. Primary differences between printers involve the formatting control codes required by the printer. These codes are sent from the Control Center to the printer. For example, Weigh-Tronix printers require a control code to select 40 column width. This same code is interpreted by the Okidata printer as an instruction to print wide characters. In some instances, a printer will ignore a code it cannot interpret.
3. The OptiView Remote Control Center requires a busy signal from the printer when the printer receive buffer is full. This causes the OptiView Remote Control Center to momentarily terminate data transmission until the printer can accept more data. The busy signal polarity must be asserted low when busy.

PRINTER CONNECTIONS

Connect the printers to the Control Center Microboard as follows. Only one printer can be connected at a time.

• OKIDATA 182, 182 turbo, 184 turbo

Microboard	Printer	Function
J2-4	pin 3	Tx (data to printer)
J2-2	pin 11	DSR (busy signal from printer)
J2-9	pin 7	Gnd
Cabinet		shield

• WEIGH-TRONIX

Microboard	Printer	Function
J2-4	pin 2	Tx (data to printer)
J2-2	pin 5	DSR (busy signal from printer)
J2-9	pin 7	Gnd
Cabinet		shield

• **SEIKO**

Microboard	Printer	Function
J2-4	pin 3	Tx (data to printer)
J2-2	pin 8	DSR (busy signal from printer)
J2-9	pin 5	Gnd
Cabinet		shield

Hardware required:

Cable – #18 AWG stranded 50ft. maximum length.

Connectors –

- Microboard: None. Strip 1/4" insulation from wire and insert into screw terminal block.
- Printers: Okidata - 25 pin plug DB-25P or equivalent; Shell DB-C2-J9 or equivalent. Weigh-Tronix - Same as Okidata. Cable assembly available from Weigh-Tronix. Seiko - 9-Pin D-type Subminiature (DB-9 pin male).

PRINTER SETUP

The selected printer must be configured as follows. Refer to manual provided by Printer manufacturer with respective Printer.

• **OKIDATA 182, 182 turbo, 184 turbo Printer**

CONTROL BOARD Switch settings:

- SW1 - on Unslashed 0
- 2 - off Unslashed 0
- 3 - off Unslashed 0
- 4 - off Form Length 11 in.
- 5 - on Form Length 11 in.
- 6 - off Auto Line Feed off
- 7 - on 8 bit data
- 8 - off Enable front panel

If equipped with a SUPER SPEED serial Board:

- SW1-1 - on Odd or even parity
- 1-2 - on No parity
- 1-3 - on 8 bit data
- 1-4 - on Protocol ready/busy
- 1-5 - on Test select
- 1-6 - on Print mode
- 1-7 - off SDD(-) pin 11
- 1-8 - on SDD(-) pin 11
- 2-1 - on 1200 Baud*
- 2-2 - on 1200 Baud*
- 2-3 - off 1200 Baud*
- 2-4 - off DSR active

- 2-5 - on Buffer threshold 32 bytes
- 2-6 - on Busy signal 200ms
- 2-7 - on DTR space after power on
- 2-8 - not used

If equipped with HIGH SPEED serial board:

- SW1 - off (-) Low when busy
- 2 - off 1200 Baud*
- 3 - off 1200 Baud*
- 4 - on 1200 Baud*
- 5 - not used
- 6 - off no parity
- 7 - off Pin 20 & pin 11 act as busy line

• **WEIGH-TRONIX Printer**

- IMP-24 Model 2600

- SW1 - off 1200 Baud*
- 2 - on 1200 Baud*

Model 1220

- Configure Menu

- Baud= 1200
- Data Bits = 8
- Stop Bits = 1
- Hshake = Busy-Line
- Cols = 32
- Invert = No
- Font = 5 x 8
- Mag = None

- Custom Menu

- Auto Seq = No
- Zero = 0
- Pound sign = #
- _(Underscore)
- Busy invert = no
- Online/offline = yes
- Ext Ch Set = no
- Print ready = yes

- Set Clock = not used
- Reset Seq = not used

• **SEIKO**

- DipSW1-1 = off Input-Serial
- 1-2 = on Printing speed high
- 1-3 = on Auto loading - on
- 1-4 = off Auto LF - off
- 1-5 = on Setting Command - Enable
- 1-6 = off Printing density - 100%
- 1-7 = on Printing density - 100%
- 1-8 = on Printing, density - 100%

DipSW 2-1= on	Printing Columns - 40
2-2 = on	User Font Back-up - on
2-3 = on	Character Select - normal
2-4 = off	Zero - slash
2-5 = on	International character set - American
2-6 = on	International character set - American
2-7 = on	International character set - American
2-8 = off	International character set - American
DipSW 3-1= on	Data length - 8 bits
3-2 = on	Parity Setting - no
3-3 = on	Parity condition - odd
3-4 = on	Busy control - H/W busy
3-5 = on	Baud rate select - 1200*
3-6 = off	Baud rate select - 1200*
3-7 = on	Baud rate select - 1200*
3-8 = off	Baud rate select - 1200*

* Settings shown for 1200 Baud. Other Baud rates can be selected. Refer to Printer manufacturer's manual supplied with Printer.

OPTIVIEW REMOTE CONTROL CENTER SETUP

Number of Units Connected

Using the Setpoints Screen, enter the number of chiller units to communicate with. The identification number of the chiller unit which is setup at the unit's control panel can not exceed this number. The identification number will appear at the top of each report.

Printer Setup

Using the PRINTER Screen, the OptiView Remote Control Center must be configured to transmit data in the same format as the Printer is configured to receive the data. The following values must be entered.

- Baud Rate - Set as desired. Value selected must be the same as Printer configuration above.
- Data Bits - 8
- Parity - None
- Stop Bits - 1

Printer Type

Using the PRINTER Screen, the actual Printer type connected to the OptiView Remote Control Center must be entered. Selection determines the control codes that are sent to the Printer. These codes determine such things as lines per inch, character width and general formatting. Available selections are: Okidata, Weigh-Tronix and Seiko.

Automatic Data Logging

If automatic data logging is desired, a Status Report can be automatically printed at a specified interval beginning at a specified time, using the PRINTER Screen. The interval is programmable over the range of 1 minute to 1440 minutes in 1 minute increments. The first print will occur at the programmed START time and occur at the programmed OUTPUT INTERVAL thereafter. The time remaining until the next print is displayed on the PRINTER Screen.

- Automatic Printer Logging - Enables and disables automatic data logging
- Log Start Time - Enter the time the first print is desired.
- Log Unit Selected - Select a unit or all units to print logs of.
- Output Interval - Enter the desired interval between prints.

Print

Pressing the **Print** button from the Unit Screen allows the operator to obtain a printout of current system operating parameters for the currently selected unit. A sample operating data printout for a YCAS chiller is shown following.

York International Corporation		Liquid Line Solenoid	= On
Unit X Status		Economizer Solenoid	= Off
X Comp Screw		Condenser Fan Stage	= 0
2:04PM 18 JUN 01		Compressor Heater	= On
System 1 No Cooling Load		<u>System 2 Data</u>	
System 2 Compressor Running		System Run	= On
System 3 No Cooling Load		System Run Time	= 15 Min
System 4 Compressor Running		Motor Current (%FLA)	= 87 %
<u>Options</u>		Suction Pressure	= 57.2 Psig
Chilled Liquid Type	= Water	Discharge Pressure	= 233.1 Psig
Ambient Control Mode	= Standard	Oil Pressure	= 218.0 Psig
Refrigerant Type	= R-22	Suction Temperature	= 42.9 °F
<u>Program Values</u>		Discharge Temperature	= 145.5 °F
Current Limit Setpoint	= 100 %	Oil Temperature	= 102.8 °F
Local/Remote Control Mode	= Remote	Saturated Suction Temp	= 31.7 °F
<u>Unit Data</u>		Suction Superheat	= 11.2 °F
Leaving Chilled Liquid Temperature	= 49.0 °F	Saturated Discharge Temp	= 112.1 °F
Return Chilled Liquid Temperature	= 58.2 °F	Discharge Superheat	= 33.4 °F
Leaving Chilled Liquid Setpoint	= 20.0 °F	Slide Valve Step	= 70
Control Range	= 2.0 °F	Cooler Inlet Refrig Temp	= 23.6 °F
Ambient Temperature	= 74.8 °F	Liquid Line Solenoid	= On
Lead System	= 2	Economizer Solenoid	= On
Evaporator Pump Contact	= On	Condenser Fan Stage	= 3
Evaporator Heater	= Off	Compressor Heater	= Off
Software Version	= C.ACS.09.03	<u>System 3 Data</u>	
<u>System 1 Data</u>		System Run	= Off
System Run	= Off	System Run Time	= 0 Min
System Run Time	= 0 Min	Motor Current (%FLA)	= 0 %
Motor Current (%FLA)	= 0 %	Suction Pressure	= 125.4 Psig
Suction Pressure	= 125.4 Psig	Discharge Pressure	= 131.3 Psig
Discharge Pressure	= 131.3 Psig	Oil Pressure	= 130.6 Psig
Oil Pressure	= 130.6 Psig	Suction Temperature	= 68.4 °F
Suction Temperature	= 68.4 °F	Discharge Temperature	= 68.8 °F
Discharge Temperature	= 68.8 °F	Oil Temperature	= 68.8 °F
Oil Temperature	= 68.8 °F	Saturated Suction Temp	= 71.8 °F
Saturated Suction Temp	= 71.8 °F	Suction Superheat	= 3.4 °F
Suction Superheat	= 3.4 °F	Saturated Discharge Temp	= 74.5 °F
Saturated Discharge Temp	= 74.5 °F	Discharge Superheat	= 6.3 °F
Discharge Superheat	= 6.3 °F	Slide Valve Step	= 0
Slide Valve Step	= 0	Cooler Inlet Refrig Temp	= 44.6 °F
Cooler Inlet Refrig Temp	= 44.6 °F	Liquid Line Solenoid	= Off
		Economizer Solenoid	= Off
		Condenser Fan Stage	= 0
		Compressor Heater	= On

FIG. 28 – OPERATING DATA PRINTOUT EXAMPLE (YCAS CHILLER)

```

York International Corporation
-----
Unit X Status
X Comp Screw

2:04PM 18 JUN 01

System 1 No Cooling Load
System 2 Compressor Running
System 3 No Cooling Load
System 4 Compressor Running

Options
Liquid Line Solenoid      = On
Economizer Solenoid      = Off
Condenser Fan Stage      = 0
Compressor Heater        = On

System 2 Data
System Run                = On
System Run Time          = 15 Min
Motor Current (%FLA)     = 87 %
Suction Pressure         = 57.2 Psig
-----
Discharge Pressure       = 233.1 Psig
Oil Pressure             = 218.0 Psig
Suction Temperature     = 42.9 °F
Discharge Temperature   = 145.5 °F
Oil Temperature         = 102.8 °F
Saturated Suction Temp  = 31.7 °F
Suction Superheat       = 11.2 °F
Saturated Discharge Temp = 112.1 °F
Discharge Superheat     = 33.4 °F
Slide Valve Step        = 70
    
```

FIG. 28 – CONTINUED

The history printout is similar to the operational data printout shown previously. The differences are in the header and the schedule information. The daily schedule is not printed for a history print. One example history buffer header printout is shown following. The data part of the printout will be exactly the same as the operating data printout.

```

York International Corporation
Unit X Safety Shutdown Number X
X Comp Screw

2:04PM 18 JUN 01

System 1 High Dsch Press Shutdown
System 2 No Faults
System 3 No Faults
System 4 No Faults
    
```

FIG. 29 – HISTORY HEADER PRINTOUT EXAMPLE (YCAS CHILLER)

SECTION 5 – SERVICE INTRODUCTION

This document explains the operation of the printed circuit boards and major components of the OptiView Remote Control Center to a level that allows a Service Technician to troubleshoot and locate the source of a problem.

The overall system architecture is described and illustrated with block diagrams. This describes the general function of each component and provides the system interface and signal flow. The function of each component and signal flow between components must be understood before effective troubleshooting can commence.

The operation of each printed circuit board is described and illustrated with a block diagram that is a simplified representation of board circuitry. The expected voltage level at all inputs and outputs of each board for any operating condition is provided.

Included in this document are procedures that have to be performed at commissioning or during service. They should not be performed by anyone other than a Service Technician. For example, calibration procedures have to be performed or verified at commissioning or when a component is replaced. Since the operating program supplied in each OptiView Remote Control Center is universal to all applications, special setpoints, program jumpers and program switches are required to configure the OptiView Remote Control Center for this locations operating conditions.

A System Commissioning Checklist is provided as reference of items to be performed during control panel commissioning.

Diagnostic Routines allow service analysis of the following functions:

- Display
- Analog inputs
- Dip switches and jumpers

Before beginning any troubleshooting, observe all display messages. The conditions required to produce the message must be clearly understood before proceeding. (If this is not heeded, much time will be wasted). Armed with a knowledge of the overall system architecture and the function of each printed circuit board and signal flow provided by this manual, proceed with the appropriate Wiring Diagram listed above to trace the problem through the system. Use the Diagnostic Routines where appropriate.

SYSTEM ARCHITECTURE (REFER TO FIG. 28)

The OptiView Remote Control Center (RCC) performs the following functions:

- Displays chiller operating conditions, alarms, shutdown messages and history data.
- Accepts operator-programmed setpoints.
- Provides chiller operating data and status to remote devices via serial communications.
- Allows real-time data and history data to be printed on an optional printer.

The RCC is a microprocessor based control system that receives analog and serial data inputs and controls serial data outputs per instructions in the operating program. A panel mounted display and touch-sensitive keypad permit remote operation.

In some applications, overall system temperatures are sensed by **thermistors** connected to the Remote Control Center. The output of each thermistor is a DC voltage that is analogous to the temperature it is sensing. Typical output voltage range of both is 0.5 to 4.5VDC. These are **analog** inputs to the Remote Control Center.

Serial Data is transmitted to and received from devices in RS-232, RS-485 and TX/RX (opto-couple) form.

All OptiView Remote Control Centers contain the following standard components:

- Microboard
- Keypad
- Display
- Power Supply

Figure 33 is a Remote Control Center block diagram of the standard components.

The microprocessor and all supporting logic circuits, along with the memory devices containing the operating program, reside on the **Microboard**. All remote control decisions are made here. In some applications it receives analog inputs from devices. The analog inputs are connected directly to the Microboard.

A front panel-mounted **Keypad** allows Operator and Service Technician user interface. Membrane keys are used to display chiller and system parameters, enter setpoints and perform chiller and Remote Control Center diagnostics.

A front panel mounted liquid crystal **Display** allows graphic animated display of the connected chiller units, chiller unit subsystems and system parameters. The chiller and working components of the chiller are displayed, along with chiller operating pressures and temperatures. The Keypad is used to select displays showing increasing levels of detail of chiller working components.

A self-contained **Power Supply** supplies the necessary DC voltages for all the components within the Remote Control Center.

Serial data interface to the YORK ISN Building Automation System is through the J12 connector.

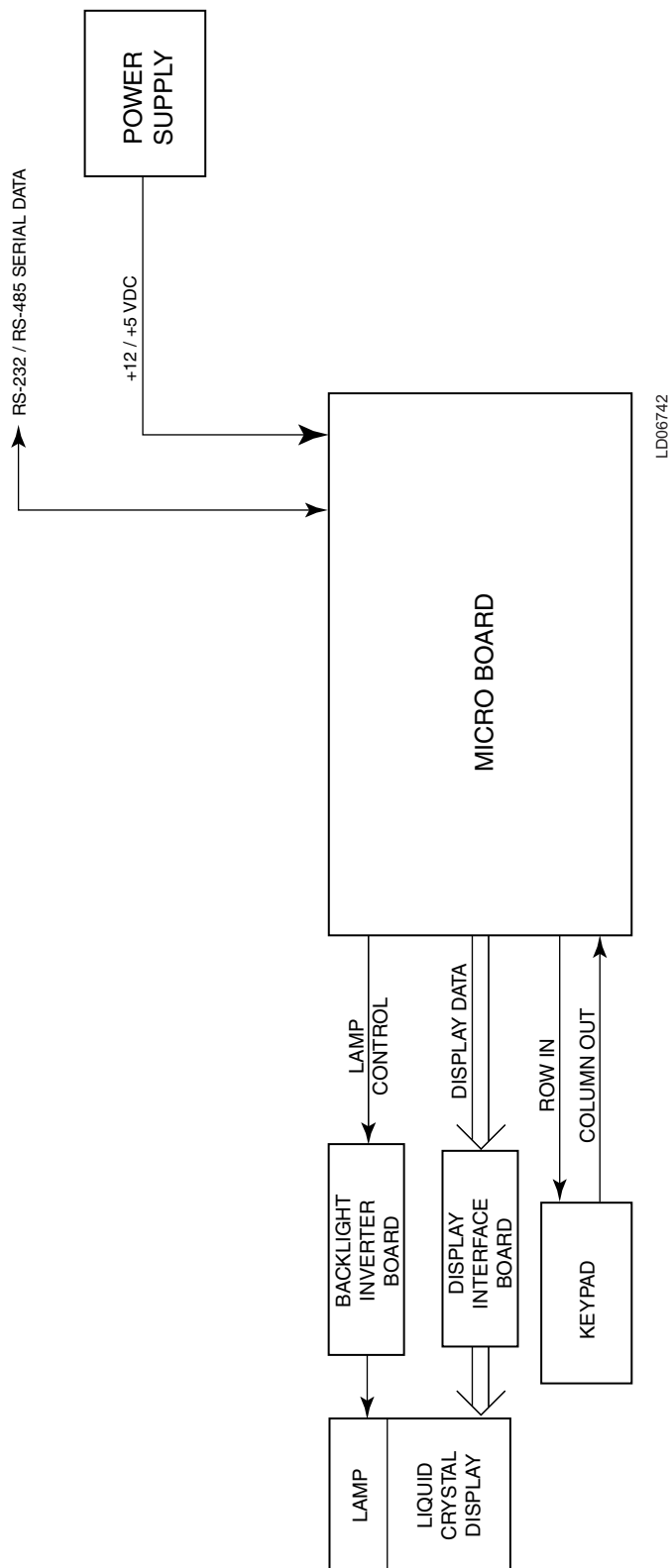
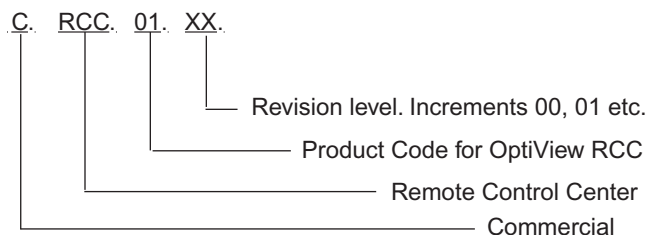

FIG. 30 – CONTROL CENTER

MICROBOARD (REFER TO FIG. 31 - 36)

The **Microboard** contains the operating software (Program), microprocessor (Micro), and supporting circuits for the Micro.

The **Program** is a set of instructions to control remote chillers and the display. It also contains the Display messages and screens. It is stored in a memory device called a **flash memory card**. This is a type of nonvolatile memory that can be read from or written to, but requires the locations to be erased before they are written to. With the exception of a write/read sequence that occurs during the Boot-up process explained below, this device is used primarily as read-only in this application. A write protect switch is located on the left edge of the card as shown in Fig. 32. It must be placed in the “Write Enabled” position in order to allow successful Boot-up. The card is located in socket location U46 (Ref. Fig. 31). It connects to the Board via an Elastomeric connector that is a silicon rubber strip embedded with silver conductors. The Card can be removed from its socket by using the thumb to press down on the socket’s plastic tension spring. The card is installed by inserting it into the socket/holder and pressing on the surface of the Card until it snaps into place. The Memory card is a replaceable component. Refer to the YORK Renewal Parts List. The version of the Memory card is an alphanumeric code that represents the application and revision level. The version is printed on a label adhered to the memory card’s surface. The version code is as follows:



The **Micro** monitors and controls the chiller by reading and executing the Program instructions in a sequence determined by the Program. Under Program control, the Micro communicates with the chillers via RS-485 serial communications to determine the operating conditions. As operating conditions require, status messages are retrieved and displayed. The Keypad is read as Digital Inputs. When an operator presses a key to request a display, the Micro interprets the request, retrieves the display from the Program and displays it. The Program assembles data in the correct format for transmission

through the Serial Data Ports to the chiller(s) and peripheral devices. The Program also instructs the Micro to respond to requests from peripheral devices for serial data transmissions.

The **Mux** (multiplexer) is a switching device that only allows one analog input through at a time. The inputs are selected sequentially by the Micro per Program instructions.

The **A/D Converter** converts each analog input to a 12-bit word. In this form, the values can be stored in memory devices, compared to values in the Program, transmitted through Serial Ports or sent to the Display Controller for display. Control signals to start conversion process are from the Micro via the FPGA.

The **Watchdog** circuit monitors the +5VDC supply from the Power Supply to determine when a power failure is occurring. Just prior to the supply decreasing to a level where the Micro and supporting circuits can no longer operate, it applies a reset signal to the Micro. The Micro responds by shutting down the remote control center and retrieving the **Power Failure** message from the Program and sending it to the Display Controller for display. Similarly, when power is first applied after a power failure, it maintains the Micro in a reset state until the +5VDC has returned to a sufficient level. The Watchdog circuit also assures that all the Program instructions are being performed and that the Program has not latched-up, bypassing important safety thresholds. If the Program has latched-up, the Micro displays **WATCHDOG – SOFTWARE REBOOT** message.

The **Program Jumpers** (Table 2) and **Program Switches** (Table 3) are used to alter the Program operation or configure the Microboard hardware for specific operation. This allows the Program and Microboard to be universal for all applications. Refer to Table 2 and 3 for the function of each jumper and switch. The position of some can be determined and set by the Service Technician to meet the desired operation. The position of others is dictated by the size, type or style of certain Control Center components and thus the position is determined by the YORK Factory. The required position of each is listed in these tables. The Program Jumpers are wire bridges that are either left in place or cut. The Program Switches are miniature switches that are placed in either the **ON** or **OFF** position.

The **DRAM** (dynamic random access memory) is a non battery-backed memory device. The Micro stores data here temporarily for further processing. Data in this device is lost during power failures. DRAM differs from RAM in that DRAM must be periodically refreshed in circuit.

The **BIOS EPROM** (basic input/output system erasable programmable read only memory) is a memory device that contains the bootstrap or power-up program. It is located in socket location U45. This EPROM is replaceable. Refer to the YORK Renewal Parts List. The EPROM version is an alphanumeric code that represents the application and revision level. The version is printed on a label adhered to the EPROM's surface. The version code is as follows:

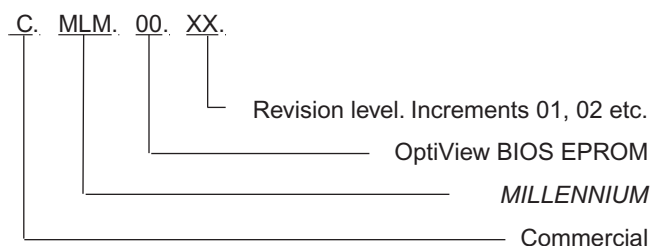

When power is applied to the Control Center following a power failure, the Micro executes the instructions in the BIOS EPROM program to initialize, configure and start operation of certain Microboard components before the main program (stored in the Flash Memory Card) is started. Depending upon the application, the Microboard could be equipped with an EPROM that has either 128K, 256K or 512K capacity. Microboard Program Jumper JP38 must be positioned according to the actual EPROM installed. Refer to Table 2 (Program Jumpers). There are 5 steps to the boot-up process. During the boot-up process, there is a visual indication as each step is performed, followed by a Pass/Fail status of the step. On the Microboard, a green LED flashes to indicate the step was successful. If a step is unsuccessful, a red LED flashes and the Boot-up process terminates. The execution and Pass/Fail status of steps 3 through 5 are displayed on a white Keypad Display Screen as they are performed. This white display screen also lists the BIOS EPROM Version. The steps of the Boot-up process are as follows. Also, below is listed the LED activity associated with each step.

BOOT-UP STEP AND DESCRIPTION

1. First initiate table complete.

Registers in the Micro are configured to allow it to perform basic memory read/write functions.

2. FPGA configuration.

The Field Programmable Gate Array (FPGA) is configured to process Digital Inputs and Outputs.

3. Mini-card signature test.

A location in the Flash Memory Card that contains a code identifying the Manufacturer is compared to other locations that contain the manufacturer's name. If these values are the same, it is **pass**. If they are different, it is **fail**.

4. Mini-card checksum.

The **Flash Memory Card** checksum is calculated and compared to the checksum value that is stored in the Card at the time the Card was initially programmed at the YORK factory. If both values are the same, it is considered **pass**. If the calculated value is different than the stored value, it is considered **fail**.

5. BRAM quick test.

Test data is written to and then read from several memory locations to verify BRAM operation.

LED INDICATORS

When power is applied to the Control Center, both the red and green LED's simultaneously illuminate for 1 second, then the Boot-up process begins in the following sequence (Note: While one LED flashes the other is off.). When all steps have been completed, both the green and the red LED's illuminate and remain illuminated.

STEP	PASS	FAIL
1	Green on, Red off	Watchdog will initiate a re-boot.
2	Green flash once	Boot-up process halts. One red flash repeating
3	Green flash once	Boot-up process halts. Two red flashes repeating
4	Green flash once	Boot-up process halts. Three red flashes repeating
5	Green flash once	Boot-up process halts. Four red flashes repeating

The **BRAM** (battery backed random access memory) is a memory device that contains a battery that preserves the data during power failures. It is a replaceable part. Refer to the YORK Renewal Parts List. It is located in socket location U52. The Micro stores the setpoints programmed by the Operator or Service Technician, History Data and other data that requires preservation, in this device. Also, the day of week, time of day and calendar date time-keeping are done here.

The **keypad** is a matrix of conductors arranged in rows and columns (ref. Fig. 45 & 46). There are 4 rows and 8 columns. When a key is pressed, the conductors are pressed together at that point, creating continuity between that row conductor and the column conductor. The Keypad is read by applying a logic low to a row while leaving +5VDC pullup on all the other rows. The Micro then reads the 8 columns. If any column has a logic low on it, the key corresponding to that coordinate (row, column) is being pressed. The Micro reads the entire Keypad by repeating this routine beginning with row 1 and ending with row 4. The entire Keypad is read every Program cycle. The Micro selects the MUX inputs (Microboard J7, J8, J9) for input to the A/D Converter by writing sequential addresses to the FPGA. The FPGA holds each address until a new one is received from the Micro. As each address is applied to the MUX, the input corresponding to that address is passed through the MUX to the A/D Converter. The A/D Converter will convert the analog value to a digital word when the Micro writes a “start conversion” pulse to the FPGA. The FPGA passes this to the A/D Converter. The Micro allows access to the PC-104 port (Microboard J16, J17) by writing an enable pulse to the FPGA. The FPGA applies this to the data transceiver, allowing data to be output to or input from the PC-104 Port.

To provide flexibility for future Analog Inputs (to Microboard J7), 2 analog inputs can be configured for either 0-10VDC or 4-20mA, Transducer or Thermistor inputs using Program Jumpers JP21 and JP22. The position of the jumper determines which type of input can be connected. Refer to Fig. 36 and Table 2, “Program Jumpers”.

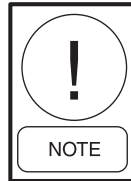

These inputs are for future YORK Factory expansion use only. They are not general application spare inputs that will support arbitrarily installed devices. Devices CANNOT be connected to these inputs until the program has been modified to read and process the input. Unless YORK documentation shows a device connected to the input with a defined function, the input cannot be used.

The Microboard receives 2 supply voltages (Microboard J1) from the **Power Supply**; +12VDC, +5VDC and Ground. The +12VDC and +5VDC are input to **Voltage Regulators** to derive other regulated voltages. The +5VDC is input to a +3.3VDC regulator. The output is a 3.3VDC regulated voltage. The +12VDC is input to a 5VDC regulator. The output of this regulator powers only the Analog circuits. This includes the MUX, A/D converter, and Thermistors. As depicted on Fig. 33, these voltages can be monitored at Test Posts TP1 through TP6.

The **Microboard** is equipped with 5 **Serial Data Ports** (ref. Fig. 35). Connector J2 is shared with both COM 1 and COM 4B. Each Port is dedicated for a specific function as follows:

- a. COM 1 (J2) - RS-232. Printer.
- b. COM 2 (J13) - RS-232. Not Used.
- c. COM 3 (J12) - RS-485. Chiller panel communications .
- d. COM 4 (4A-J11), (4B-J2) - This port is actually two ports. However, they cannot be used simultaneously; only one of these ports can be connected to a device at a time. The position of Microboard Program Jumper J27 determines which port can be used (refer to Table 2). COM 4A (J11) is an RS-485 port that is used for Multi-Unit Communications. COM 4B (J2) is an RS-232 port that is used for MicroGateway.
- e. COM 5 (J15) – Not Used.

COM 1 is connected directly to the Micro. COM 2 through 5 are connected directly to the **UART** (Universal Asynchronous Receive Transmit). The UART converts the parallel data to serial form for transmission to the peripheral device and converts the incoming serial data to parallel form for use by the Micro. It also generates and processes control signals for the Modem communications (DTR, CTS, DSR, RTS). Under Program control, the Micro instructs the UART of the desired data transmission Baud rate. A crystal oscillator provides the frequency reference. Each port is equipped with two LED'S; a red one indicates when data is being transmitted to the remote device and a green one indicates when data is being received from the remote device. The RS-232 output voltages are industry standard ± 3 to ± 15 VDC, with ± 9 VDC typical. The RS-485 output voltages are industry standard ± 1.5 to ± 5 VDC, with ± 2.5 VDC typical. A loopback diagnostic test can be performed on each serial port. This test permits verification of the data transmitted from the serial port. Refer to the "Serial Inputs / Outputs Tests" description in this book for details of these tests. The graphic screens that are displayed on the **Liquid Crystal Display** are created from preformed graphics and messages that are stored in the Program (FLASH Memory Card), and real-time system operating parameters, such as temperatures. The graphics, message and number data are in the form of digital words. The **Display Controller** converts this data into display drive signals and sends them to the Display from Microboard J5. The Display has 307,200 pixels arranged in a 640 columns x 480 rows matrix configuration. Each pixel consists of 3 windows; red, green and blue, through which a variable amount of light from the Display **backlight** is permitted to pass through the front of the display. Imbedded in each window of the pixel is a transistor, the conduction of which determines the amount of light that will pass. The drive signal determines the amount of conduction of the transistor and therefore the amount of light passed through the window. The overall pixel color becomes a result of the gradient of red, green and blue light allowed to pass. The drive signal for each pixel is an 18 bit binary word; 6 for each of the 3 colors, red, green and blue. The greater the binary value, the greater the amount of light permitted to pass. The pixels are driven sequentially from left to right, beginning with the top row. To coordinate the drive signals and assure the pixels in each row are driven sequentially from left to right and the columns are driven from top to bottom, each drive signal contains a horizontal and vertical sync signal.

The **Display DRAM** is a memory device that supports the operation of the **display controller**. This device could be either of two types; FPM (fast page mode) or EDO (extended data out) type. Program Jumper JP6 must be positioned according to the type of DRAM device installed in the Microboard; JP6 in - EDO, out - FPM. Refer to Table 2, "Program Jumpers". Depending upon the requirement, there could be one or two DRAM devices installed in the Microboard. If the design requires only one DRAM, it is installed in socket U27. If an additional one is required, it is installed in socket U25.

During the power-up sequence, the program in the BIOS EPROM reads Program Jumper JP6 to determine the type of **Display DRAM** installed (as explained above). It also reads wire jumpers PID0 through PID3 (via Microboard J5) on the **Display Interface Board** to determine the manufacturer of the display (refer to description of Display Interface Board). Each display manufacturer requires a slightly different control. The program in the BIOS EPROM then configures the **Display Controller** for operation with the actual display that is present.

Different Display manufacturers can require different supply and control voltages for their displays and backlights. Program Jumpers JP 2 through 4 and 5 through 8 must be configured to provide the required supply and control voltages to the display and backlight control. Table 2 lists the required Program Jumper configuration for the Display. Also, a label attached to the Display mounting plate lists the required Program Jumper configuration for that particular Display.

The power supply voltage that operates the **Display** is provided by the Microboard J5. The position of Program Jumper JP2 determines whether this supply voltage is +5VDC or +3.3VDC. The **Display** requires a specific power-up and power-off sequencing to prevent damage. During power-up, the supply voltage must be applied to the **Display** before the drive signals are applied. Similarly, during power-off sequencing, the display drive signals must be removed prior to removing the supply voltage. The **Display Controller** applies the supply voltage and data drive signals to the **Display** in the proper sequence. The **Display Controller** controls the **Display Backlight** by applying control signals (from Microboard J6) to the **Backlight Inverter Board**. The **Backlight Inverter Board** converts low voltage DC (+12VDC or +5VDC, depending on position of

Program Jumper JP5) to high voltage AC (500 to 1500VAC). This high voltage AC is applied to the lamp to cause it to illuminate. The **Backlight** is turned on and off with the “Enable Backlight” (J6-5) signal. The position of Program Jumper JP4 determines whether this is a +12VDC or +5VDC signal. In some displays, the **Backlight** turns on when this signal transitions from low to high; others turn on when it transitions from high to low. The position of Program Jumper JP3 determines the transition that will occur when the Display Controller outputs the “Enable Backlight” signal. Program Jumper JP3 must be positioned according to the Display manufacturer’s requirement.

Under Program control, the **Display Controller** controls the Backlight brightness via the **Lamp Dimmer** circuit. In order to extend the life of the backlight lamp, the lamp brightness is driven to 50% brightness after 10 minutes of Keypad inactivity. At this brightness level, the Display can still be read. Subsequently, when Keypad activity is detected (i.e. a Keypad key is pressed), the lamp is driven back to full brightness (100% brightness). Some display manufacturers require a variable voltage to vary the brightness; others require a variable resistance. Program Jumpers JP7 and JP8 allow either method to be used. The **Lamp Dimmer** is an integrated circuit that is the electrical equivalent of a 10K ohm potentiometer with 100 positions or steps (ref. Fig. 34). The **Display Controller** controls the position of the potentiometer. The **Lamp Dimmer** varies the brightness of the Backlight by applying either a variable voltage (0-5.0VDC) or a variable resistance (0-10K ohms), to the **Backlight Inverter Board**. If Program Jumpers JP7 and JP8 are installed, the **Lamp Dimmer** output is a variable voltage; if both are removed, the output is a variable resistance. The Lamp Dimmer outputs “Brightness Control Wiper” (J6-7) and “Brightness Control -“ (J6-8) to the **Backlight Inverter Board**. If configured for variable voltage output, the voltage between J6-7 and J6-8 can be varied from 0 (100% brightness) to 5.0VDC (0% brightness). If configured for variable resistance, the resistance between J6-7 and J6-8 would vary from 0 ohms (0% brightness) to 10K ohms (100% brightness).

The **PC-104 Port** (J16 & J17) is an industry standard arrangement of two connectors that allows the stacking of 3.6 x 3.8 inch printed circuit boards (PC-104 Modules) on the Microboard. The circuits on these boards have access to the Microboard’s address/data bus, and therefore become an extension of the Microboard. This provides expansion of the Microboard’s capabilities without redesigning or changing the size of the Microboard. PC-104 Modules are not used in all Remote Control Center applications.

System temperatures, in the form of analog DC voltages from temperature thermistors, are input to the **MUX** (multiplexers). Under Program control, the Micro selects these values, one at a time, for input to the Analog to Digital (A/D) converter. As each one is selected, it is passed to the **A/D Converter** for conversion to a 12-bit digital word that is then input in parallel form to the Micro. The Micro stores each value in the **DRAM** for display requests, further processing or Serial Port transmission. Each value is also stored in the **BRAM** for History data.

Service Replacement: Microboards are supplied as Service Replacement parts without the following components:

- BRAM (U52)
- Flash Memory Card (U46)
- BIOS EPROM (U45)

Upon receipt of the replacement Microboard, remove these components from the Board being replaced and install in the replacement Board. Although these components have YORK Part Numbers as listed in the Parts List and can be individually replaced, it is recommended that these existing components be used in the new Board since the BRAM memory device contains all of the programmed setpoints.

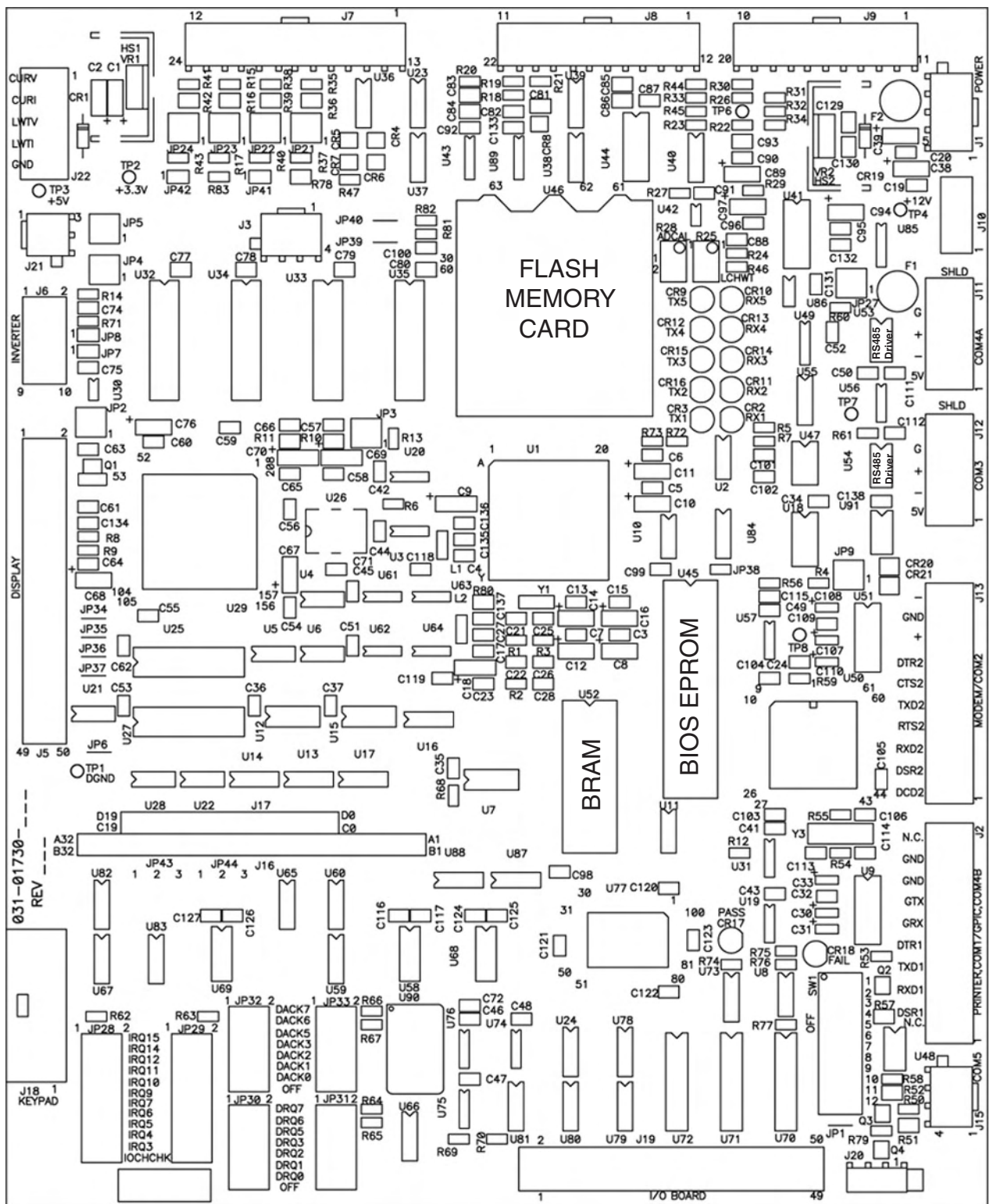

LD06743

FIG. 31 – MICROBOARD

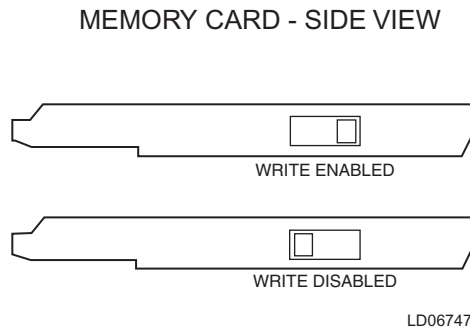
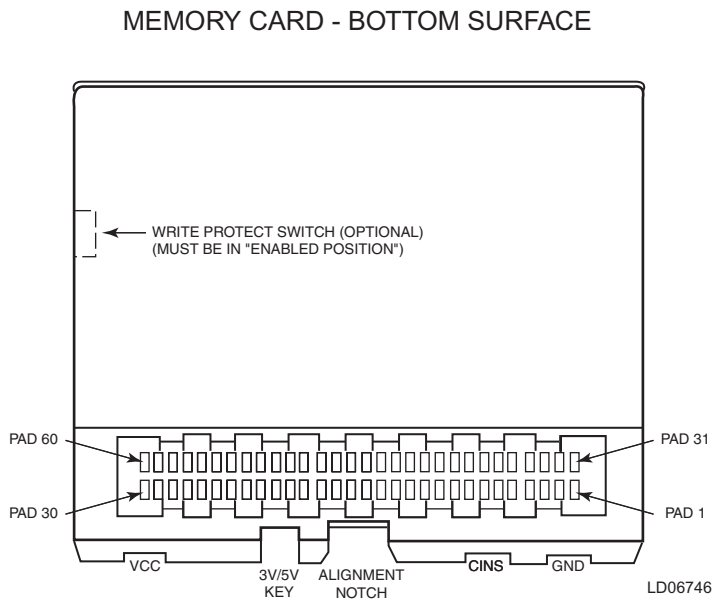
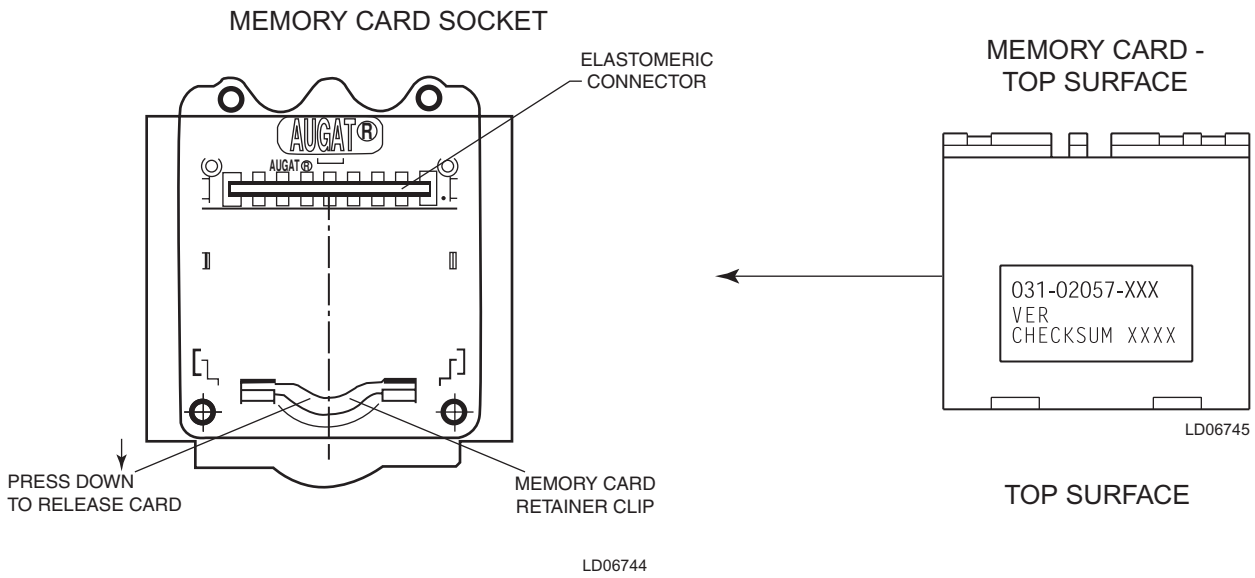
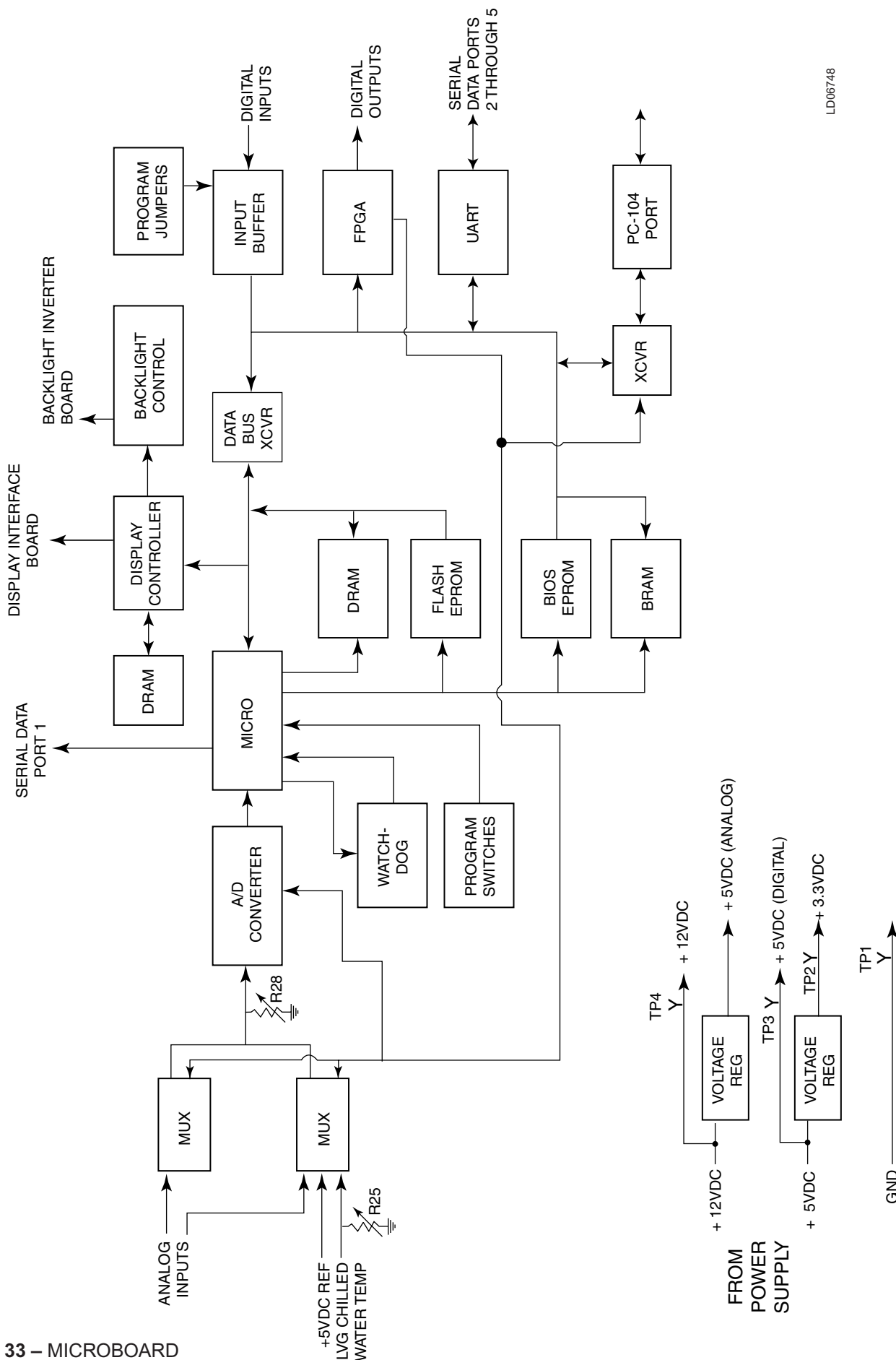

FIG. 32 – FLASH MEMORY CARD



LD06748

FIG. 33 – MICROBOARD

TABLE 2 – MICROBOARD PROGRAM JUMPERS

MICROBOARD PROGRAM JUMPERS

JP1 - Watchdog enable/disable. The position of this jumper, in conjunction with Program switch SW 1 position 12 enables or disables the program Watchdog protection.



Never disable the watchdog protection. Severe compressor or chiller damage could result. The ability to disable the watchdog protection is provided for factory testing only!!!

IN - Watchdog protection enabled.

OUT - Permits Program switch SW1 position 12 to enable or disable the program

Watchdog protection as follows:

Position 12 **ON** - Watchdog protection enabled

OFF - Watchdog protection disabled

JP2 - Display power and logic levels. Determines the power supply voltage applied to the display.

Pins 1-2: +5VDC SHARP LQ10D367

Pins 2-3: +3.3VDC LG Semicon LP104V2 displays.



If this jumper is not correctly installed the display could become damaged.

JP3 - Display backlight enable signal level polarity. Jumper must be positioned according to the voltage level required to turn on the Display Backlight.

Pins 1-2: 0VDC (Not used)

Pins 2-3: +12VDC or +5VDC as determined by position of JP4. SHARP LQ10D367 and LG Semicon LP104V2 displays.

JP4 - Display backlight enable signal logic levels. Determines the logic levels of the Backlight enable signal.

Pins 1-2: +12VDC/0VD (Not used)

Pins 2-3:+5VDC/0VDC LG Semicon LP104V2 displays.

JP5 - Display backlight power. Determines the power supply voltage applied to the Display Backlight Inverter Board.

Pins 1-2: +12VDC. SHARP LQ10D367 and LG Semicon LP104V2 displays.

Pins 2-3: +5VDC. (Not used)

JP6 - Display memory type. Jumper must be positioned according to type of RAM used for display memory devices (U25 & U27).

IN - EDO: (extended data out) type. Jumper should be IN.

OUT - FPM: (fast page mode) type. Not used at this time.

JP7, JP8 - Display brightness control technique. Determines whether the display brightness is controlled by a variable voltage or variable resistance.

IN: Variable voltage (0-5.0VDC). SHARP LQ10D367 and LG Semicon LP104V2 displays.

OUT: Variable resistance. (Not used)

JP9 - COM 2 serial communications port. Configures COM 4 port to be either RS-485 or RS-232.

Pins 1-2: RS-232

Pins 2-3: RS-485

JP10 - JP26 - Not used.

JP27 - COM 4 serial communications port. Configures COM 4 port to be either RS-485 for Multi-Unit Communications (COM 4A) or RS-232 for MicroGateway board (COM4B).

Pins 1-2: Enables port 4A. Allows an RS-485 connection to Microboard J11 for MultiUnit Communications.

Pins 2-3: Enables port 4B. Allows an RS-232 connection to Microboard J2 for MicroGateway communications.

JP28 - PC-104 Port interrupt assignment. Assigns selected PC-104 interrupt request to PDRQ7 on the microprocessor. Interrupt request selections are silk screened on the Microboard adjacent to the program jumper. Not used.

JP29 - PC-104 Port interrupt assignment. Assigns selected PC-104 interrupt request to PDRQ6 on the microprocessor. Interrupt request selections are silk screened on the Microboard adjacent to the program jumper. Future modem application.

JP30 - PC-104 Port DMA assignment. Assigns selected PC-104 DMA request to PDRQ0 on the microprocessor. DMA request selections are silk screened on the Microboard adjacent to the program jumper. Not used.

JP31 - PC-104 Port DMA assignment. Assigns selected PC-104 DMA request to PDRQ1 on the microprocessor. DMA request selections are silk screened on the Microboard adjacent to the program jumper. Not used.

JP32 - PC-104 Port DMA acknowledge assignment. Assigns selected PC-104 DMA acknowledge to PDACK0 on the microprocessor. DMA acknowledge selections are silk screened on the Microboard adjacent to the program jumper. Not used.

JP33 - PC-104 Port DMA acknowledge assignment. Assigns selected PC-104 DMA acknowledge to PDACK1 on the microprocessor. DMA acknowledge selections are silk screened on the Microboard adjacent to the program jumper. Not used.

JP34, JP35, JP36, JP37 - Not Used

JP38 - BIOS EPROM U45 size. Jumper must be positioned according to size of U45. Jumper is a 10 Ohm resistor that is soldered to board. It is not a shunt jumper.

IN: 512K

OUT: 128K or 256K. Should be OUT for OptiView Remote Control Center applications.

JP39, JP40, JP41, JP42 - Not used.

TABLE 3 – MICROBOARD PROGRAM SWITCHES

SW1

1 - Simulator mode - When this switch is closed or in the ON position, the RCC simulates the data from 4 chillers and will not communicate with any attached units.

ON: Simulator mode enabled. Used for demonstration.

OFF: Simulator mode is disabled. The unit must be powered on with the switch in this position for the RCC to communicate with attached units and operate normally.

2 - Not Used

3 - Not Used

4 - Diagnostics - Enables or disables software diagnostics

ON: Enables software diagnostics. Disables normal control center operation

OFF: Disables software diagnostics. Enables normal control center operation.

5 - 11 Not Used

12 - Watchdog Protection -Used in conjunction with Program Jumper JP1 (see above) to enable/disable the program watchdog protection. With JP1 **IN**, this switch setting has no effect. With JP1 **OUT**, this switch setting determines whether the watchdog protection is enabled or disabled.



NEVER disable the watchdog protection! Severe compressor or chiller damage could result. The ability to disable the watchdog protection is provided for YORK factory testing only.

ON: Watchdog protection enabled.

OFF: Watchdog protection disabled.

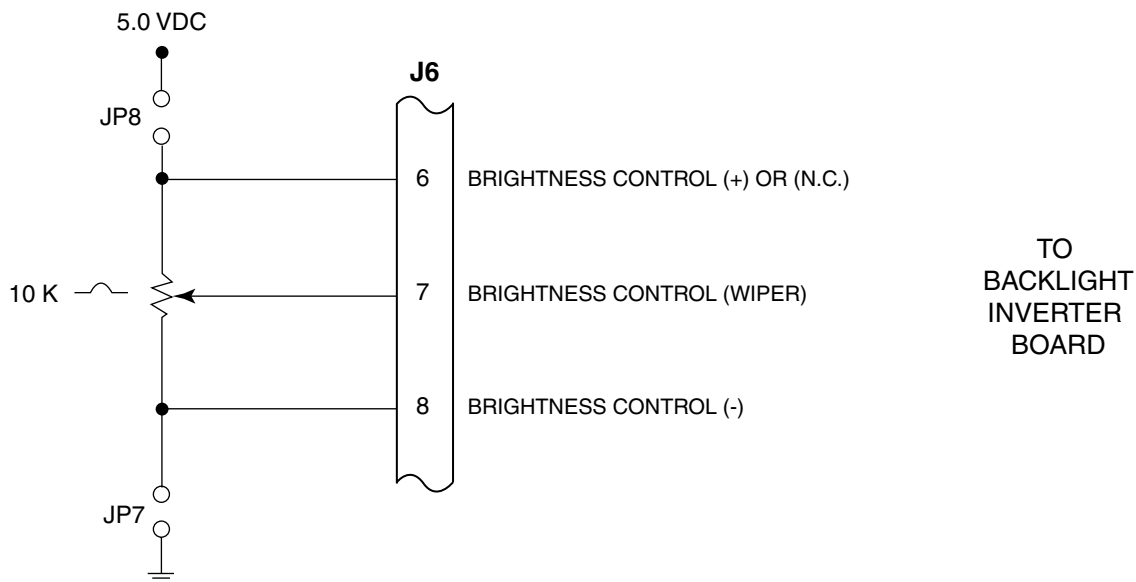

LD04054

NOTES:

1. J6-6 not connected (N.C.) to Backlight Inverter Board when display is manufactured by Sharp or NEC.
2. The position of Program Jumpers JP7 & JP8 determine the output at J6-7; In = Variable Voltage; Out = Variable Resistance. Refer to Program Jumper Listing in Table 2 for applications.
3. Potentiometer is actually an integrated circuit that is the electrical equivalent of a 10K potentiometer.

FIG. 34 – MICROBOARD LAMP DIMMER CIRCUIT

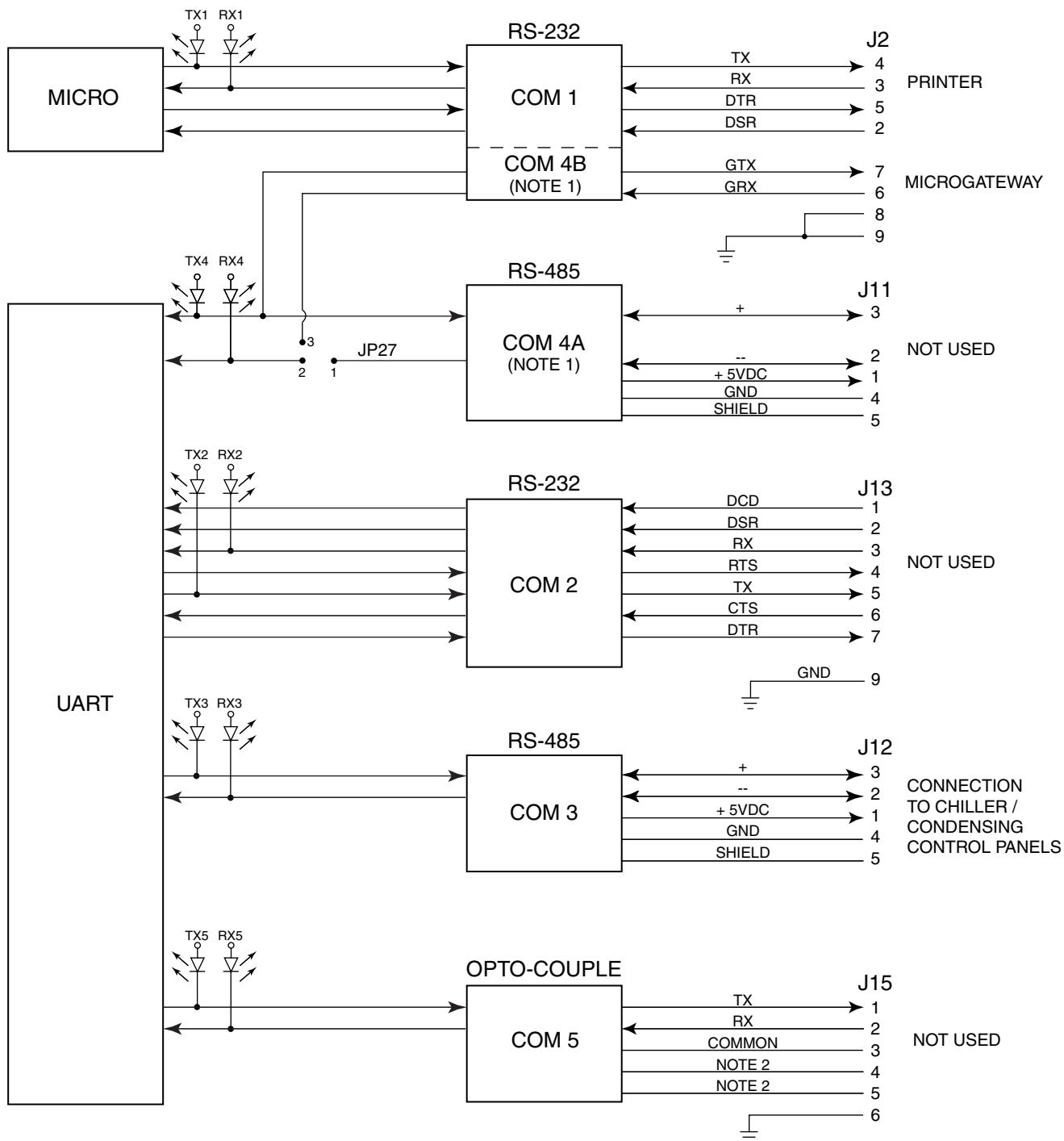

NOTE:

1. Microboard Program Jumper JP27 determines whether COM 4A or 4B can be used. 1 & 2 - 4A, 2 & 3, 4B. Refer to Table 2.

FIG. 35 – MICROBOARD SERIAL DATA COMMUNICATIONS PORTS

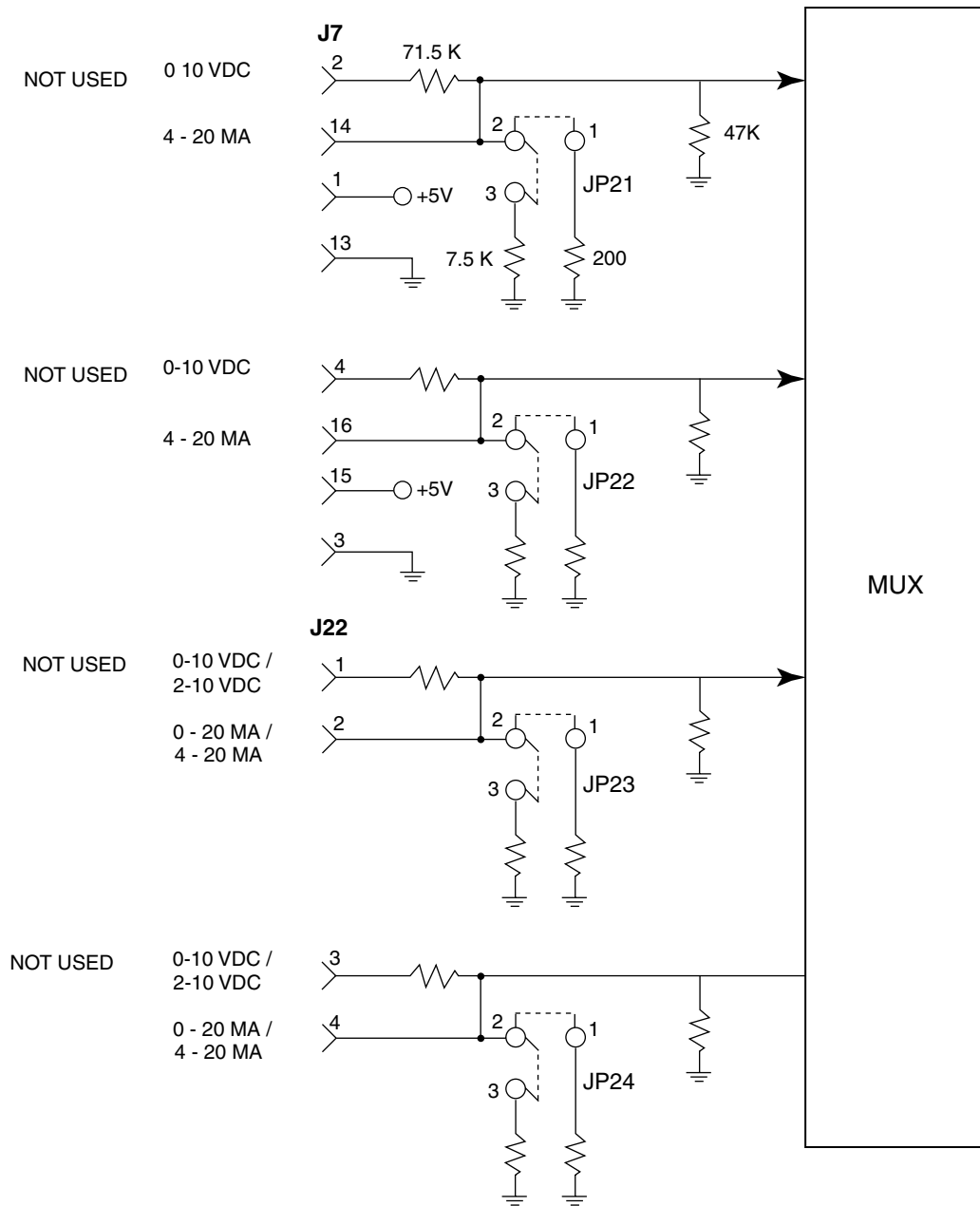

LD04636

NOTE:

1. Program Jumpers JP21 – JP24 must be positioned on pins 1-2 or 3-4 according to input signal type. Refer to Table 2.

FIG. 36 – CONFIGURABLE ANALOG INPUTS

LIQUID CRYSTAL DISPLAY (REFER TO FIG. 37 - 42)

A 10.4 inch color **Liquid Crystal Display**, along with supporting components **Display Interface Board** and **Backlight Inverter Board** are mounted on a plate that is attached to the OptiView Control Center door. A clear plexiglass faceplate prevents display surface damage. System operating parameters are displayed on various color graphic screens. The various display screens are selected for display using the Keypad keys.

The Display provided in the OptiView RCC or from YORK as a service replacement part, could be manufactured by any of several approved manufacturers. Each Display requires a specific Display Interface Board, Backlight Inverter Board, Inverter Board interface cable and Program command set. **Therefore, Service replacement Displays or supporting components cannot be arbitrarily selected!!!** As explained below, replacement Displays are provided from YORK as kits to assure compatibility of all components. **Non-compatibility of components will result in incorrect operation!!!** Refer to “Display Interface Board” and “Backlight Inverter Board” descriptions that follow. The following displays could be provided from YORK in new OptiView RCCs or as replacement parts:

- LG SEMICON LP104V2
- SHARP LQ10D367

The YORK part numbers of the Display Interface Board, Backlight Inverter Board and Inverter ribbon cable provided, are listed on a label attached to the Display mounting plate. These are the part numbers of the supporting components that are compatible with the installed display. These supporting components can be individually replaced. However, if the Liquid Crystal Display fails, Display replacement kit 331-02053-000 must be ordered as detailed below. This kit contains a replacement Display and all compatible supporting components.

The Display has 307,200 pixels arranged in a 640 columns X 480 rows matrix configuration. Each pixel consists of 3 windows; red, green and blue, through which a variable amount of light from the Display Backlight is permitted to pass through the front of the display. Imbedded in each window of the pixel is a transistor, the conduction of which determines the amount of light that will pass through the window. The conduction of each transistor is controlled by a signal from the Display Controller on the Microboard. The overall pixel color is a result of the gradient of red, green and blue light allowed to pass.

Under Program control, the Display Controller on the Microboard sends a drive signal for each pixel to create the image on the display. Each pixel’s drive signal is an 18 bit binary word; 6 bits for each of the 3 colors, red green and blue. The greater the binary value, the greater the amount of light permitted to pass. The columns of pixels are driven from left to right and the rows are driven top to bottom. To coordinate the drive signals and assure the columns are driven from left to right and the rows are driven from top to bottom, each drive signal contains a horizontal and vertical sync signal. The **Display Interface Board** receives these display drive signals from the Microboard J5 and applies them to the Display at connector CN1. Refer to Fig. 43.

Although there are variations in control signal timing between different display manufacturers, Fig. 38 depicts typical control signals. Since these control signals occur at rates greater than can be read with a Voltmeter, the following description is for information only. There are 480 horizontal rows of pixels. Each row contains 640 3-window pixels. Beginning with the top row, the drive signals are applied within each row, sequentially left to right, beginning with the left most pixel and ending with the right most pixel. The rows are driven from top to bottom. The Vertical Sync (VSYNC) pulse starts the scan in the upper left corner. The first Horizontal Sync (HSYNC) pulse initiates the sequential application of RGB drive signals to the 640 pixels in row 1. Upon receipt of the **ENABLE** signal, an RGB drive signal is applied to the first pixel. As long as the **ENABLE** signal is present, RGB drive signals are then applied to the remaining 639 pixels at the CLK rate of 25.18MHz, or one every 39.72 nanoseconds. Typically it takes 31 microseconds to address all 640 pixels. Similarly, the next HSYNC pulse applies drive signals to row 2. This continues until all 480 rows have been addressed. Total elapsed time to address all 480 rows is approximately 16 milliseconds. The next VSYNC pulse causes the above cycle to repeat. Displays can be operated in **FIXED** mode or **DISPLAY ENABLE** mode. In **FIXED** mode, the first pixel drive signal is applied a fixed number (48) of clock (CLK) cycles from the end of the HSYNC pulse and the drive signals are terminated a fixed number (16) of CLK cycles prior to the next HSYNC pulse. In **DISPLAY ENABLE** mode, the pixel drive signals are applied to the pixels only while **ENABLE** signal is present. This signal is typically present 4-48 CLKS after the end of the HSYNC pulse and 2-16 CLKS prior

to the next HSYNC pulse. All YORK applications operate in the **DISPLAY ENABLE** mode. The state of the **ENABLE** (Display Interface Board J1-27) signal from the Microboard places the Display in the desired mode as follows:

- LG SEMICON Display does not have the fixed mode feature.

As described above, in OptiView Control Center applications, the Display scan is left to right, beginning with the top row and continuing sequentially through the rows to the last row. However, in Display applications other than OptiView Control Centers, image reversal is sometimes required. In image reversal applications, the scan is reversed; the scan is right to left, beginning with the last row and proceeding to the top row.

Displays by different manufacturers can require different timing and control signals. The Microboard must know which Display is present in order to provide the correct signals. Therefore, when AC control power is first applied to the OptiView Control Center, as part of the power-up sequence, the Microboard reads the Panel ID wire jumpers P1D0 - P1D3 on the **Display Interface Board** and determines which Display is present. It can then provide the correct timing and control signals to produce the graphic image, as required by the Display manufacturer. Since the **Display Interface Board** identifies the Display for the Microboard, there is a different **Display Interface Board** required for each Display application and each has a unique jumper configuration that identifies the Display. A complete explanation of this process is included in the preceding “Microboard” description and the “Display Interface Board” description that follows.

The DC power source to operate the Display is provided by the Microboard J5. Some Display manufacturers require +5VDC; others require +3.3VDC. The position of Microboard Program Jumper JP2 determines which of these power sources is supplied to the Display. JP2 must be positioned according to the Display manufacturers requirements. Refer to Table 2, “Program Jumpers”.

The **Backlight Lamp** provides the illumination for the display. Average lamp life is 25000 hours (2.9 years). Some displays use one lamp. Others use two lamps. Lamps are replaceable, but not interchangeable between different displays. Each Display manufacturer specifies the required lamp for their display. Refer to replacement parts list for appropriate replacement lamp. Service replacement lamps are stocked in the YORK Service Parts

Distribution Center. The lamp is illuminated by applying a high voltage AC (500 to 1500VAC) to it. This illumination voltage is created from a low level DC voltage (+12VDC or +5VDC as required by the Display manufacturer) by the **Backlight Inverter Board**. Lamp brightness is controlled by varying the high voltage AC. The greater the voltage the brighter the illumination. The lamp is controlled by on/off commands and brightness control signals applied to the **Backlight Inverter Board** from the Microboard. The Microboard Program determines when the lamp is turned on and off and the lamp brightness. Each Display manufacturer specifies the **Backlight Inverter Board** to be used. Therefore, it will vary according to the Display manufacturer. The ribbon cable that connects the Microboard to the Backlight Inverter Board also varies according to the Display manufacturer’s requirements. Refer to Fig. 44. Microboard Program Jumpers JP3, 4, 5, 7 and 8 determine the voltage levels of the control signals sent to the **Backlight Inverter Board** and must be configured per the Display manufacturer’s requirements as listed in Table 2. A detailed description of the operation of this board is in the “Backlight Inverter Board” description that follows. Also refer to the preceding “Microboard” description for a detailed description of the **Lamp Dimmer** circuit.

The actual Display that is installed in the OptiView Control Center of the new chiller is determined by the Display manufacturer contractual agreement in place during the time of OptiView Control Center production. Displays stocked for Service replacement are a result of that same agreement. Therefore, the Display received for service replacement may be by a different manufacturer than the one in the OptiView Control Center. Since each Display manufacturer requires a specific Display Interface Board, Backlight Inverter Board and Inverter Ribbon Cable, replacement Displays are ordered and supplied as a Display Replacement Kit (YORK Part Number 331-02053-000) to assure component compatibility. The items supplied in the kit are compatible with the supplied Display. The kit consists of the following items mounted on a Display mounting plate:

Display Replacement Kit 331-02053-000:

1. Liquid Crystal Display with Lamp
2. Appropriate Display Interface Board for item 1
3. Appropriate Backlight Inverter Board for item 1
4. Appropriate ribbon cable (Backlight Inverter Board to Microboard) for item 1
5. Ribbon cable (Display Interface Board to Microboard)
6. All mounting hardware
7. Installation instructions. A label attached to the

Display mounting plate lists the YORK part numbers of the Display supporting components mounted on the Display mounting plate and the required Microboard Program Jumper (JP2 through 8) configurations. **Microboard Program Jumpers JP2 - JP8 will have to be configured appropriately for the replacement display. Refer to Table 2 “Program Jumpers”.**

Display Handling:

1. The display is made of glass. It could break if dropped.
2. The display front surface is easily scratched. If soiled, wipe with a dry cotton cloth. Use no water or chemicals.
3. The display is static sensitive. Electrostatic discharges may damage the display.
4. A laminated film is adhered to the display front glass surface to prevent it from being scratched. Peel off very slowly to prevent static damage.



Always remove control power from the OptiView Remote Control Center before connecting or disconnecting wires to the display. Connecting or disconnecting wires to the display with power applied will damage the display!!!

BACKLIGHT LAMP REPLACEMENT:

SHARP LQ10D367 Display: (Refer to Fig. 41)

Removal:

The Lamp slides into the Display from left to right and is secured with a locking tab.

1. Remove Control Power from the OptiView Control Center.
2. Remove protective cover from rear of Display.
3. Disconnect Lamp AC power connector from Backlight Inverter Board.

4. Using fingernail or thin flat blade screwdriver, bend the locking tab outward slightly to clear the Lamp housing protrusion.
5. Grasp Lamp AC power connector and gently pull until Lamp housing clears locking tab.
6. Grasp Lamp housing and pull until Lamp housing is completely removed from the Display.

Installation:

1. Slide new Lamp into Display from left to right until Lamp housing protrusion locks into Display locking tab.
2. Connect Lamp AC power connector to Backlight Inverter Board.
3. Apply Control Power to OptiView Control Center.

LG Semicon LP104V2 Display (refer to Fig. 42)

Removal:

The Lamp slides into the Display from left to right and is secured with a screw.

1. Remove Control Power from the OptiView Remote Control Center.
2. Remove protective cover from rear of Display.
3. Disconnect Lamp AC power connector from Backlight Inverter Board.
4. Using small Phillips screwdriver, remove lamp retaining screw.
5. Grasp Lamp AC power connector and gently pull until Lamp housing is completely removed from the Display.

Installation:

1. Slide new Lamp into Display from left to right until Lamp housing is fully inserted.
2. Secure Lamp with Lamp retaining screw.
3. Connect Lamp AC power connector to Backlight Inverter Board.
4. Apply AC power to OptiView Remote Control Center.

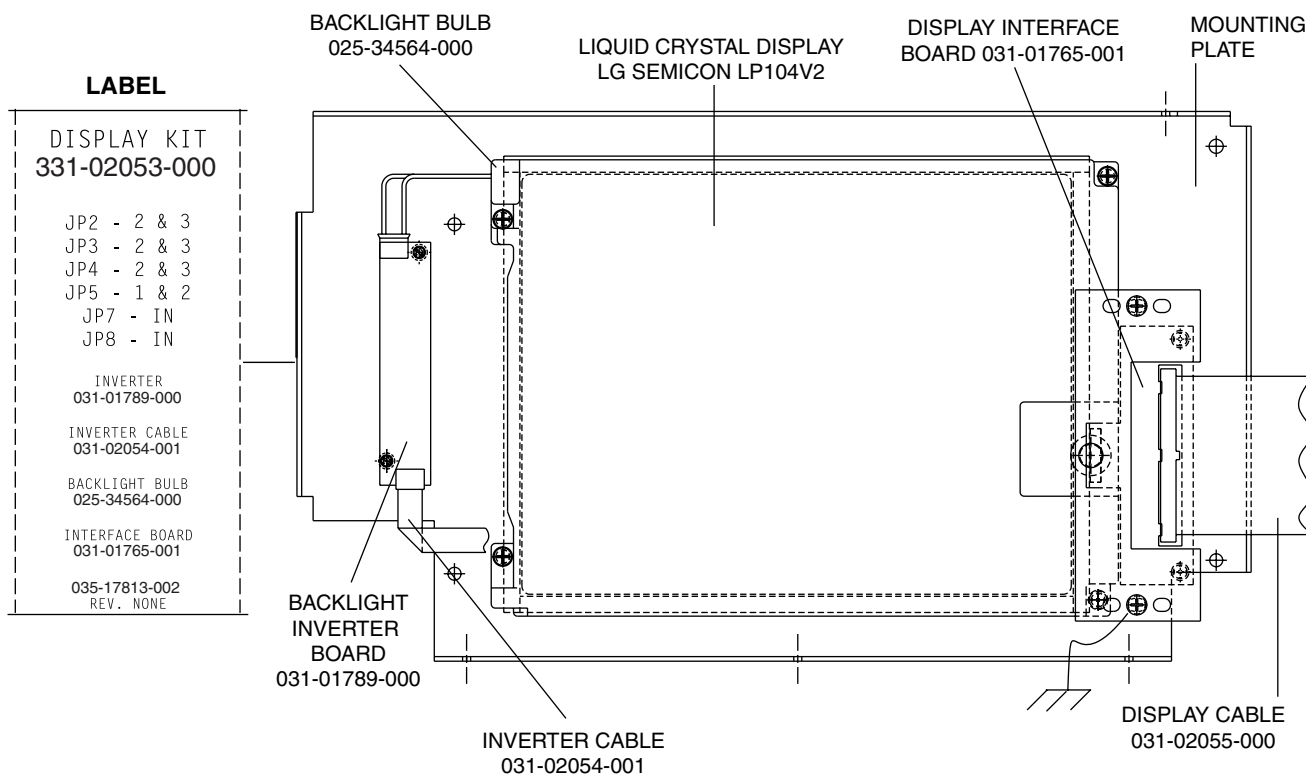

NOTE:

1. Configure Microboard Program Jumpers per label.

LD06752

FIG. 39 – LIQUID CRYSTAL DISPLAY ASSEMBLY - LG SEMICON LP104V2

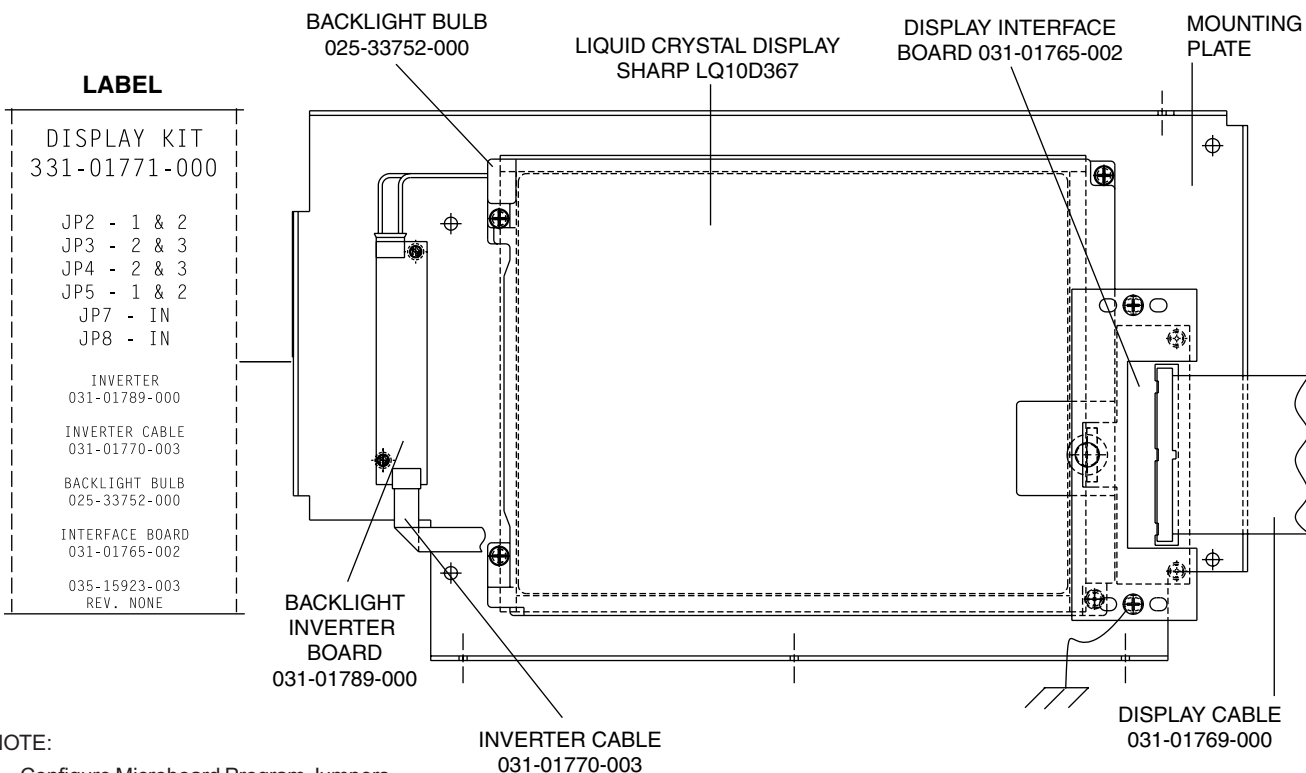

NOTE:

1. Configure Microboard Program Jumpers per label.

LD06753

FIG. 40 – LIQUID CRYSTAL DISPLAY ASSEMBLY - SHARP LQ10D367

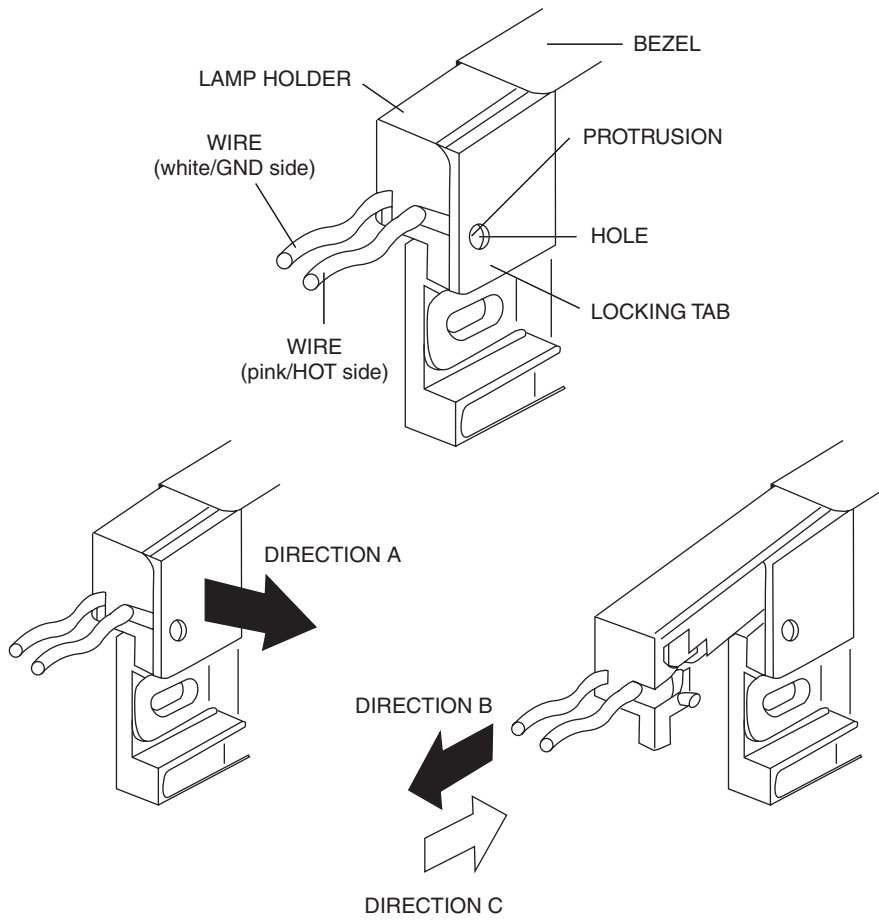

LD04067

FIG. 41 – DISPLAY (SHARP LQ10D367) LAMP REPLACEMENT

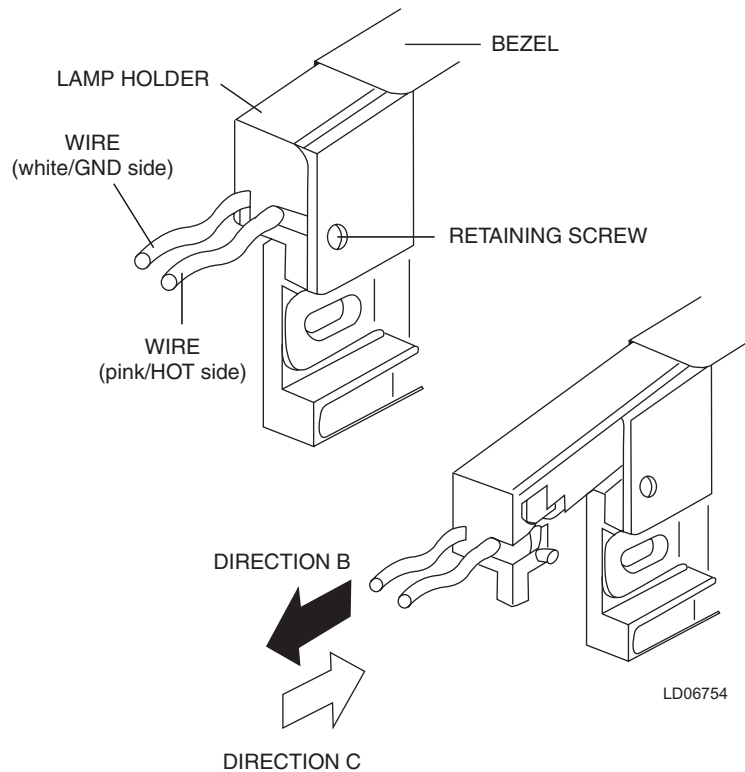

LD06754

FIG. 42 – DISPLAY (LG SEMICON LP104V2) LAMP REPLACEMENT

DISPLAY INTERFACE BOARD (REFER TO FIG. 43)

The **Display Interface Board** is located on the **Liquid Crystal Display** mounting plate and is part of the Microboard interface to the Display. It permits the use of Displays by different manufacturers, by providing the Microboard with a means of automatically determining which Display is present.

Since different Display manufacturers require different timing and control signals, the Display Controller on the Microboard must be configured to meet the requirements of the actual Display installed. When AC power is applied to the OptiView Remote Control Center, as part of the power-up sequence, the Microboard reads the four Panel ID wire jumpers, PID0 through PID3, on the **Display Interface Board** to determine which Display is present. The configuration of these jumpers indicates the actual Display that is installed on the OptiView Remote Control Center door. The Display Controller on the Microboard is then configured appropriately.

On Sharp displays the configuration of wire jumpers P30 and P31 determines whether the Display scan orientation is Normal or Reverse (image reversal) scan. As described in the preceding "Display" description, Normal scan is left to right, beginning with the top row and continuing sequentially through the rows to the bottom row. Normal scan is used in OptiView Remote Control Center applications. In Display applications other than OptiView RCC applications, image reversal is sometimes required. In image reversal applications, the scan is reversed; the scan is right to left, beginning with the bottom row and proceeding to the top row. The jumper configurations determine the voltage level at Display Interface Board J1-30 (P30) and J1-31 (P31). If P30 is IN, the voltage at J1-30 is +5.0VDC or +3.3VDC (as determined by position of Microboard Program Jumper JP2); if OUT, 0VDC. If P31 is IN, the voltage at J1-31 is GND; if OUT, 0VDC. The Display reads these voltages and adopts a scan mode as follows:

SHARP LQ10D367 & LQ10D421 Displays:
SHARP displays require configuration of both jumpers to achieve total image reversal.

P30 IN - Normal scan; left to right
 OUT - Reverse scan: right to left

P31 IN - Normal scan; top to bottom
 OUT - Reverse scan; bottom to top

The wire jumpers on this board are not field configurable, as with typical Program Jumpers. There are two variations of the **Display Interface Board**. Each board has the wire jumpers configured appropriately for the display to which it is attached, as shown below. **Display Interface Boards** are available individually for service replacement. The YORK part number of the Display Interface Board compatible with the installed Display is listed on a label attached to the Display mounting plate. However, service replacement Displays are provided as a kit (331-02053-000) that includes, among other items, the appropriate **Display Interface Board** for the Display included in the kit. Refer to explanation in "Liquid Crystal Display" description.

031-01765-001:

Display applicability - LG Semicon LP104V2
Jumper configuration - PID0 - IN
 PID1 - OUT
 PID2 - OUT
 PID3 - OUT
 P30 - OUT
 P31 - OUT

031-01765-002:

Display applicability - SHARP LQ10D367
Jumper configuration - PID0 - OUT
 PID1 - IN
 PID2 - OUT
 PID3 - OUT
 P30 - IN
 P31 - IN

The red, green and blue display drive and control signals are simply passed through the **Display Interface Board**. The value of VCC is either +5VDC or +3.3VDC, as determined by the position of Program Jumper JP2 on the Microboard. PID0 through PID3, when installed, connect their respective Microboard (J5) inputs to GND; when removed, the Microboard pulls these signals up to +5VDC. When P30 is installed, the Display input (CN1-30) is connected to VCC (+5VDC or +3.3VDC as determined by Microboard Program Jumper JP2). When P31 is installed, the Display input (CN1-31) is connected to GND.

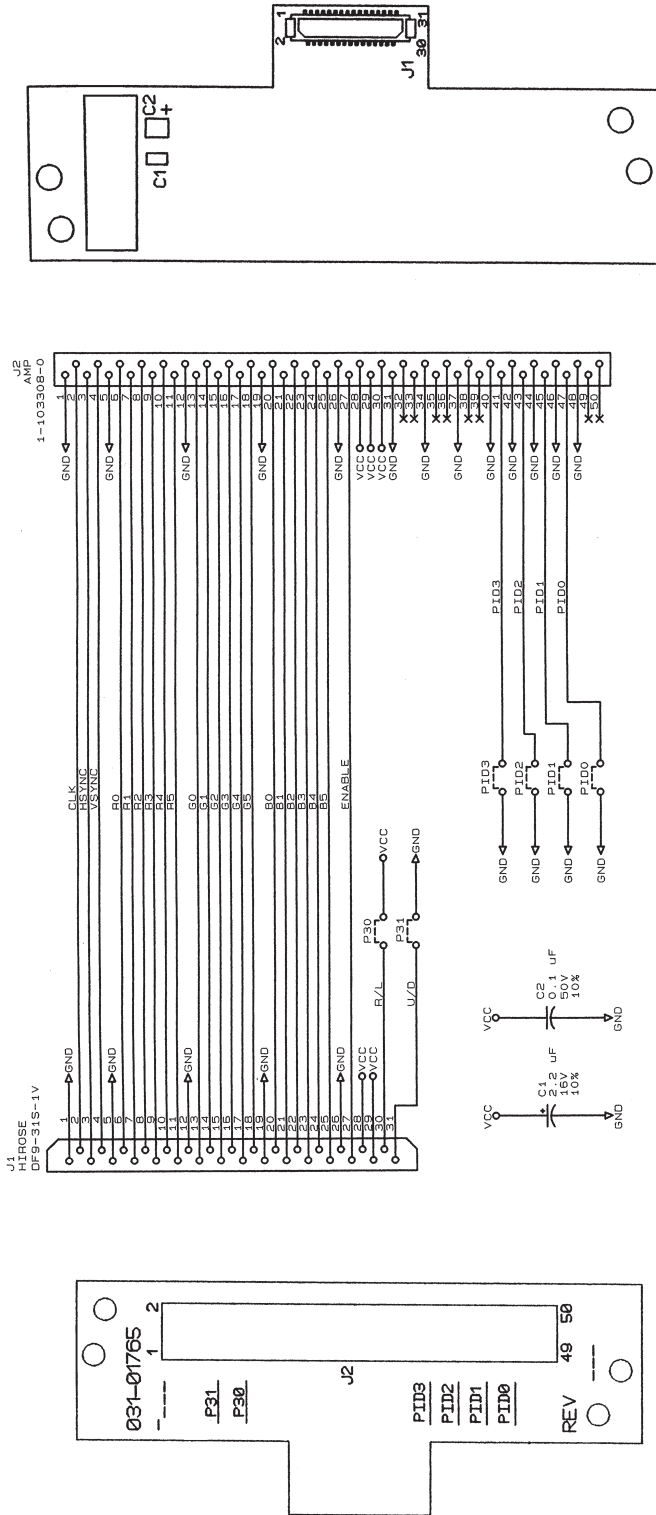

LG SEMICON LP104V2

031-01765-001	-	PID0	IN
		PID1-3	OUT
		P30, P31	OUT
SHARP LQ10D367			
031-01765-002	-	PID0	OUT
		PID1	IN
		PID2, 3	OUT
		P30, 31	IN

LD04070

FIG. 43 – DISPLAY INTERFACE BOARD

DISPLAY BACKLIGHT INVERTER BOARD (REFER TO FIG. 44)

The **Display Backlight Inverter Board** generates a high voltage AC signal that is applied to the backlight lamp, causing it to illuminate. The magnitude of the signal determines the lamp brightness. Displays by some manufacturers have two lamps; one at the top and one at the bottom of the display. Other Display manufacturers have only a lamp at the top of the display.

An **Inverter** converts low level DC voltage (+12VDC or +5VDC, as required by the manufacturer) from the Microboard to a 500 to 1500VAC 60KHz signal that is applied to the lamp. The higher the AC voltage, the greater the brightness of the lamp. When this voltage is not present, the lamp is turned off.



High voltage, up to 1500VAC, is present at the output of the backlight inverter board. Refer to Figure 44 and locate the output connectors. Use extreme caution when working in this area!!!

Different Display manufacturers require different Backlight Inverter Boards. The different board designs require different control voltage inputs. To accommodate these variations, Microboard Program Jumpers JP3 - JP5, JP7 and JP8 must be configured to provide the required voltage levels. A label attached to the Display mounting plate lists the required Program Jumper configuration for that particular display. Refer to Table 2 for required Program Jumper configurations for the various Display applications.

Under Program control, the Microboard generates the control signals that are applied to the Backlight Inverter Board. The Program determines when the lamp is turned on and off. It also adjusts the lamp brightness. To increase the average lamp life of 25000 hours, the lamp brightness is normally adjusted to 50%. This brightness level will still allow the display to be visible. When the Program senses a Keypad key has been pressed, it adjusts the brightness to 100% (maximum).

The lamp illumination high voltage AC is generated from either +12VDC or +5VDC as required by the manufacturer. Microboard Program Jumper JP5 must be positioned to provide the required voltage. The Microboard provides the **Backlight Enable** signal. This signal turns the lamp on and off. Some manufacturers require this signal to be +12VDC, others require +5VDC.

Program Jumper JP4 must be positioned to provide the required voltage. Further, some applications require this signal to be a +VDC (+12VDC or +5VDC) to turn on the lamp. Others require this signal to be 0VDC to turn on the lamp. Program Jumper JP3 must be positioned to provide the required polarity.

Depending upon the Display manufacturer, the brightness control input from the Microboard must be either a variable voltage or a variable resistance. Microboard Program Jumpers JP7 and JP8 are used to provide the appropriate technique (refer to Fig. 34). The lamp dimmer circuit on the Microboard is an IC that is the electrical equivalent of a 10K ohm potentiometer with 100 positions or steps. The Program adjusts the position of the potentiometer. When configured for variable voltage (JP7 & JP8 installed), the output between Microboard J6-7 and J6-8 is a 0 to +5.0VDC signal. Not all applications require the full 5.0VDC range. If configured for variable resistance (JP7 and JP8 removed), the output between Microboard J6-7 and J6-8 is a 0 to 10K ohm variable resistance.

The OptiView Remote Control Center could be supplied with any of several approved Displays. Each Display requires a specific Backlight Inverter Board. This board is available as a service replacement part (the required Backlight Inverter Board part number is listed on the label attached to the Display mounting plate). However, service replacement Displays are provided in a kit (YORK P/N 331-02053-000) that includes the appropriate Backlight Inverter Board (refer to “Liquid Crystal Display” description).

SHARP model LQ10D367 and LG Semicon LP104V2 display requires a TDK CXA-LO612-VJL Backlight Inverter Board (YORK P/N 031-01789-000) (ref. Fig. 39 and Fig. 40). These boards generate a lamp illumination high voltage AC from +12VDC. When the Backlight Enable signal at connector CN1-3 is +5VDC, the high voltage signal is applied to the lamp. When CN1-3 is 0VDC, the high voltage signal is removed from the lamp, turning it off. The lamp brightness is controlled by a variable voltage signal, developed by the lamp dimmer circuit (ref. Fig. 34) on the Microboard and applied to connector CN1-4. The lamp dimmer circuit varies the voltage at CN1-4 over the range of 0 to +3.0VDC. 0VDC produces maximum (100%) brightness; +3.0VDC produces minimum (0%) brightness. Voltages between these values produce a linear brightness 0 and 100%. Connector CN2 applies the high voltage lamp illumination signal to the lamp.

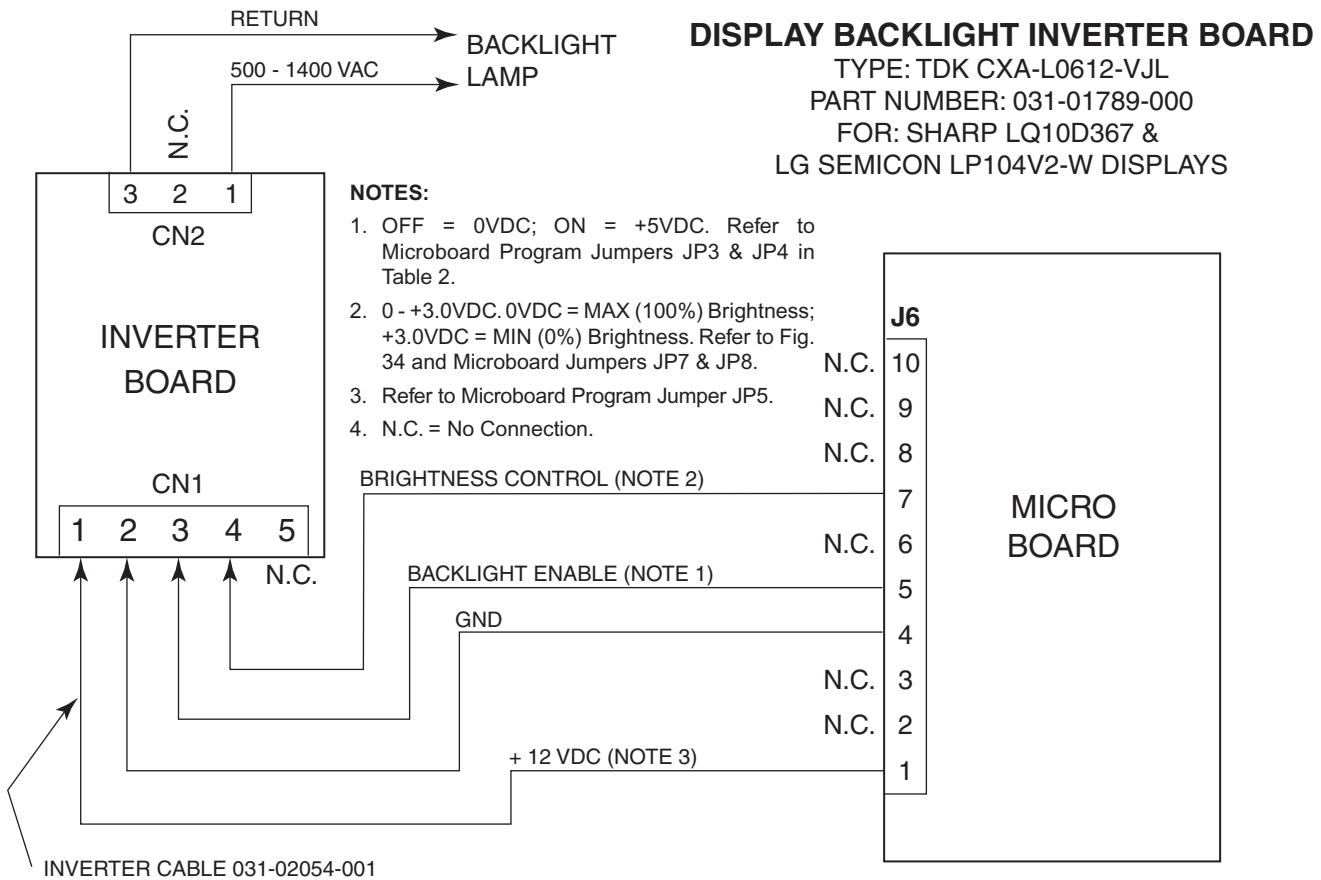

LD06755

FIG. 44 – DISPLAY BACKLIGHT INVERTER BOARD

KEYPAD (REFER TO FIGURES 45 & 46)

The **Keypad** contains touch-sensitive keys that allow the Operator to interface with the Control Center. The Operator presses the keys to request the desired screens of information and enter System Setpoints.

The top layer of the Keypad contains embossed areas identifying the keys. Under each embossed key area are two conductors, one on top of the other, separated by an air space. The conductors are arranged in a matrix of rows and columns and connected to the Keypad connector as shown in Fig. 46. The embossed area of each key is located directly over the intersection point of the conductors. Pressing the embossed key area causes contact and electrical continuity between the two conductors. For example, pressing the “1” key creates continuity between the Keypad connector pin 5 (column 3) and pin 13 (row 4). Since this connector is interfaced to the Microboard (J18), the Microboard senses this continuity as described below and concludes the “1” key is pressed.

The Microboard Program continuously scans the Keypad to determine if a key is pressed. Beginning with row 1 and proceeding through all rows, the Program places a “logic low” (<1VDC) on a row, a “logic high” (>4VDC) on the remaining rows and reads the columns. A logic low in any column indicates a key in that column and row is pressed. For example, if at the time row 4 is being driven low, if column 3 is low, then the Micro

concludes the key at coordinate of row 4 and column 3 is pressed. Since the coordinates of all keys are stored in the Microboard’s Program, it can identify which key is at this coordinate and responds accordingly. In this example the “1” key is pressed.

In order for the Microboard to reliably detect closed and open keys, each key must meet a closed circuit and open circuit resistance requirement. When a key is pressed, the contact resistance must be ≤ 100 Ohms. When a key is not pressed, the contact resistance must be ≥ 1 Meg Ohm. If the Microboard is not responding to a pressed key, or if it’s detecting a closed key when none are pressed, it could be because the contact resistance requirements are not being met. The operation of each key can be checked with an Ohmmeter. To check the open and closed contact resistance of any key, refer to the “Diagnostics and Troubleshooting” description in this book.

The Keypad is attached to the front of the Remote Control Center door with an adhesive backing. If service replacement is required, start at one corner and slowly peel the Keypad from the door. The rear side of the replacement Keypad is coated with an adhesive covered with a paper backing. Remove the paper backing, align the Display opening and apply the Keypad to the door.

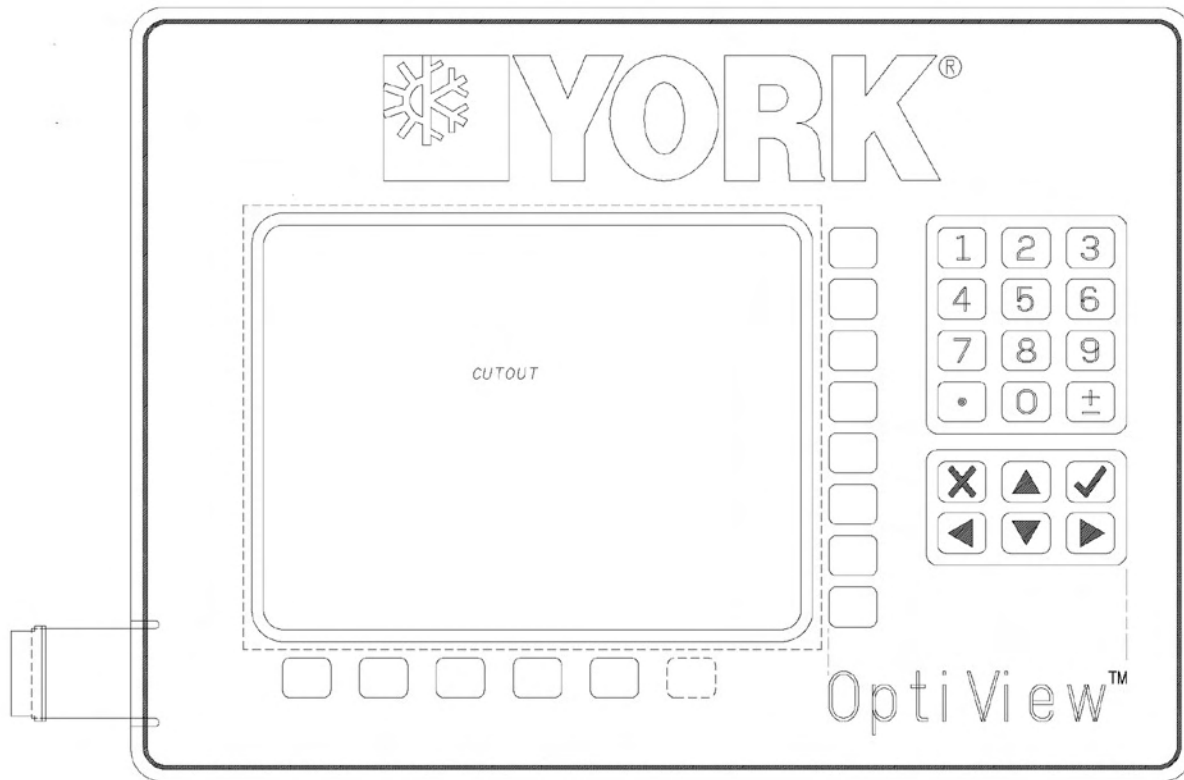

LD06756

FIG. 45 – KEYPAD

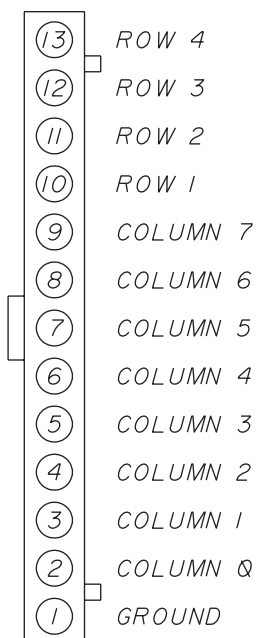
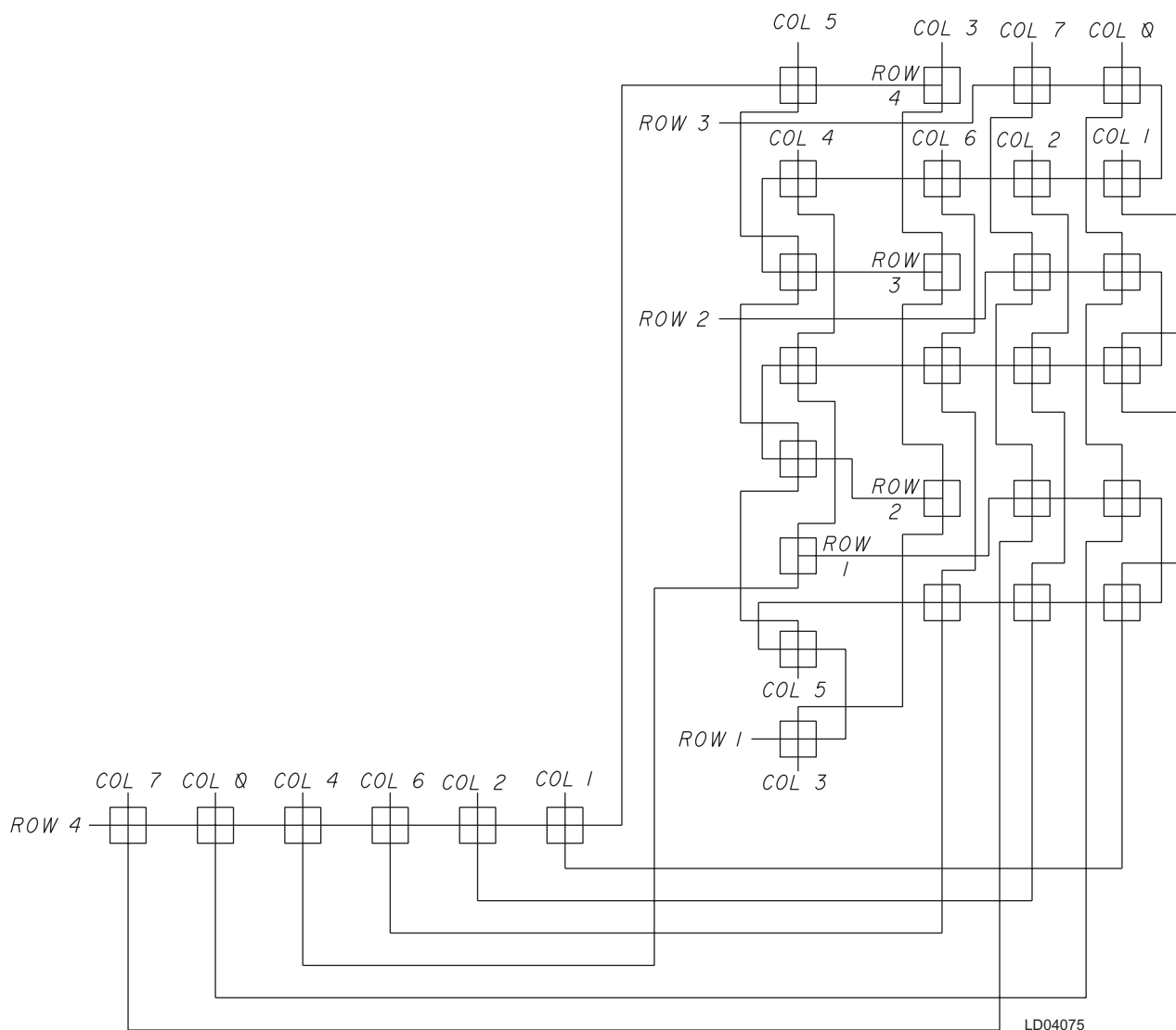

FIG. 46 – KEYPAD

CONNECTOR PIN OUT

LD04076

POWER SUPPLY (REFER TO FIG 47)

The Power Supply provides the DC power for the LCD Display and all the printed circuit boards in the Control Center. It receives a 100 to 250VAC input from an external power source and provides the following DC outputs:

- +12VDC
- +5VDC
- Ground

The +12VDC, Gnd and +5VDC outputs are applied to the Microboard. There, these voltages are applied to the circuits requiring the respective voltage. From the Microboard, the +12VDC and +5VDC are distributed to other system components requiring these voltages. These include the MicroGateway, LCD Display and Display Backlight Inverter Board.

As shown in Fig. 47, the Microboard contains two voltage regulators that create separate +5VDC and +3.3VDC supplies. The +5VDC supply is dedicated to all the Microboard Analog circuits and is labeled

as the +5VDC (Analog) supply. It is also routed to all Temperature Thermistors. This permits all Analog circuits to be powered by the same supply, eliminating any offsets caused by voltage regulator drift. The +3.3VDC supply is utilized by the Microprocessor, Flash Memory Card and other digital circuits. It could also be applied to the Backlight Inverter Board, depending on the Display manufacturer's requirements as explained next.

Different Display manufacturers can require different supply voltages for their display and supporting circuits. To accommodate the different Display manufacturer's voltage requirements, Microboard Program Jumpers JP2 and JP5 must be positioned to provide the required supply voltages to the Display and the Display Backlight Inverter Board. Either +5VDC or +3.3VDC, as determined by JP2, is applied to the Display. Either +12VDC or +5VDC, as determined by JP5, is applied to the Display Backlight Inverter Board. Refer to Table 2 "Microboard Program Jumpers".

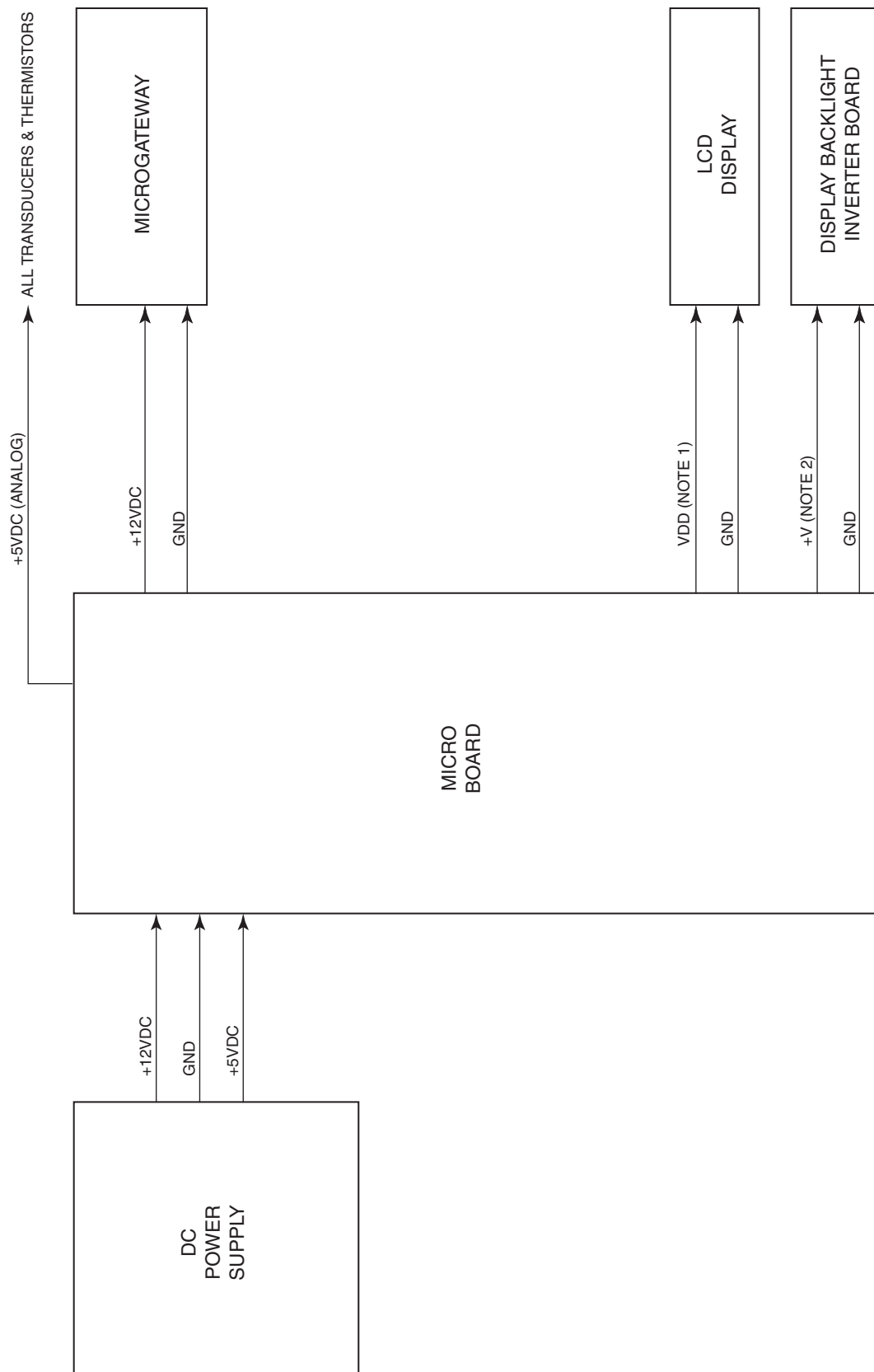

NOTES:

1. +5 or +3.3VDC as determined by Microboard Program Jumper JP2 & display requirements.
2. +12 or +5VDC as determined by Microboard Program Jumper JP5 & display requirements.

LD06757

FIG. 47 – POWER SUPPLY – DC POWER DISTRIBUTION (REFER TO CONTROL CENTER WIRING DIAGRAM FOR WIRE CONNECTIONS)

OFFLINE DIAGNOSTICS & TROUBLESHOOTING (REFER TO FIG 48 & 49)

The problems that could be encountered in the Control Center are in the following categories:

- Keypad
- Display
- Serial Input/Output (I/O)
- Digital Input/Output (I/O)
- Analog Inputs

There is a Diagnostic and associated Troubleshooting procedure for each category. They are described on the following pages. The offline diagnostics are accessed from the Diagnostics Main Screen, which is entered using the procedure below. If there is a Remote Control Center problem, determine the category of the problem. Then perform the applicable Diagnostic. If the Diagnostic reveals a malfunction, perform the Troubleshooting procedure to locate the defective component.

There are several documents that must be referred to while performing the Diagnostics and Troubleshooting procedures. Each procedure references the Section and figures of this book that describe the operation of the component being tested.

The Offline diagnostic screens are only available when the panel is powered on (or rebooted) with the Diagnostics Enable dip switch in the Enabled position. When in this mode all normal RCC functions are disabled. If the Diagnostics Enable dip switch is placed in the Disabled position while the panel is in the Offline Diagnostics mode, the Diagnostics task will cause the panel to reboot into the online diagnostics mode.

MAIN DIAGNOSTICS SCREEN

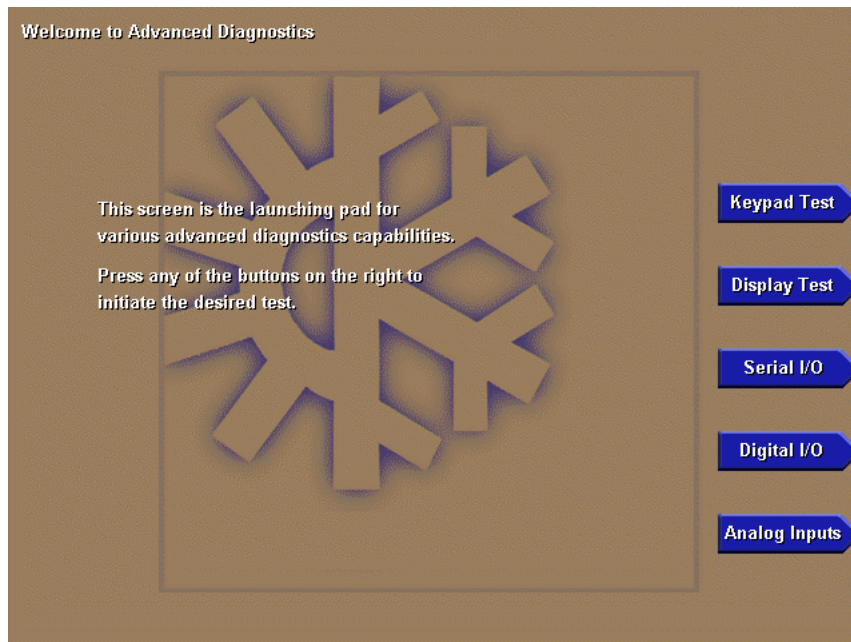

FIG. 48

00527VIPC

Each of the Offline Diagnostics is accessed from this screen. Press the appropriate key to select the desired diagnostic. After each diagnostic is performed, return to this MAIN Screen, from which the next diagnostic can be selected.

Some of the diagnostics have sub-screens that are accessed from the selected diagnostic screen. The sub-screens are shown indented:

Main screen

- Keypad test
- Display test
 - Bit patterns test
 - All red
 - All green
 - All blue
 - All white
 - All black
- Serial I/O
- Digital I/O
- Analog Inputs

KEYPAD TEST



FIG. 49

00568VIPC

This diagnostic is used to verify Keypad operation and the Microboard's ability to respond to a pressed key. Refer to description of Keypad operation in Section 5 of this book.

Procedure

1. Press each keypad key. As the key is pressed, an illuminated LED is displayed corresponding to the key location on the keypad.
2. Press the DIAGNOSTICS key to return to the MAIN DIAGNOSTICS Screen.

Troubleshooting

If an LED is not displayed when a key is pressed, the Keypad, Keypad ribbon cable or Microboard could be defective. Use the following procedure to locate the defective component.

1. Keypad
 - a. Disconnect the ribbon cable from the Keypad.
 - b. Identify row/column coordinate of the key to be tested. Refer to Figure 46.

- c. In the Keypad connector, locate the pins of the row/column coordinate of the key of the key to be tested.
- d. Insert the leads of an Ohmmeter into the pins identified in step "c" above.
- e. Press the key to be tested. If the contact resistance is >100 Ohms, the Keypad is defective.
- f. Release the key. If the contact resistance is < 1 Meg Ohm, the Keypad is defective.

2. Ribbon Cable

Using an Ohmmeter, perform a continuity test on all conductors in the ribbon cable. An open circuit would indicate the ribbon Cable is defective.

3. Microboard

There are no checks or measurements to be made on the Microboard. If the Keypad and Ribbon Cable check OK per the above procedures, the Microboard is most likely the cause of the problem.

DISPLAY TEST

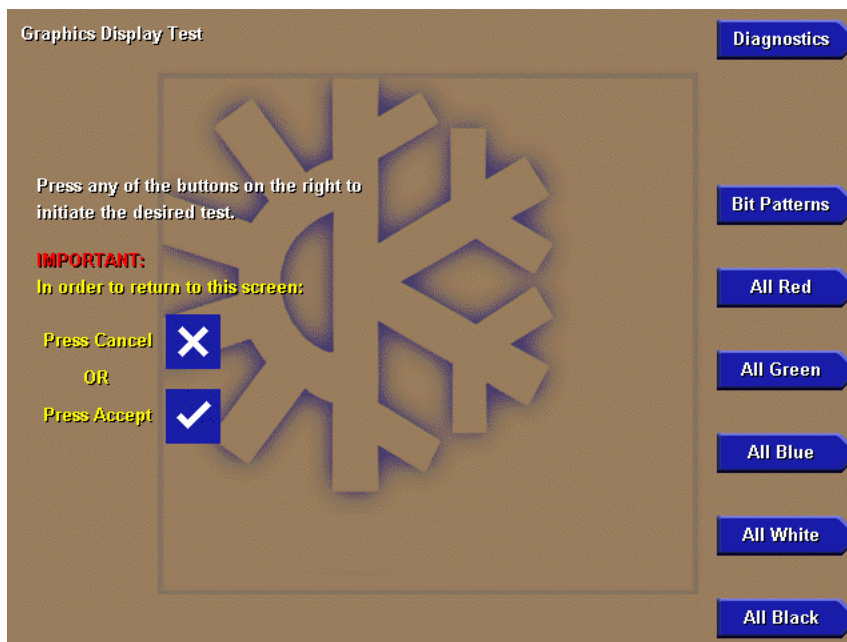

FIG. 50

00528VIPC

Each of the Display Diagnostics is accessed from this screen. After each diagnostic is performed, return to this screen, from which the next diagnostic can be selected. Refer to description of Display operation in Section 5 of this book.

PROCEDURE

1. Press the appropriate keypad key to perform the desired test from the list below.
2. Press the CANCEL (X) or ENTER (T) key to terminate test and return to DISPLAY TEST MAIN Screen, from which another test can be selected.
3. When all the desired tests have been performed, press the DIAGNOSTICS key to return to the MAIN DIAGNOSTICS Screen.
 - **Bit Patterns** - This test is used to detect jitter and alignment defects. It verifies proper operation and compatibility of the Microboard Display Controller with the display. Four vertical bars of green, dark blue, light blue and yellow, outlined by a red border are displayed. If the vertical bars are not stable or straight, or the red border is not completely visible, then either the Microboard Program Jumpers are not configured correctly for the installed display or the Microboard Display controller is defective. Refer to Figure 51.
 - **All Red** - This test verifies the operation of all of the red pixels. All of the red pixels are turned on to create a completely red screen. Any red

pixels that do not turn on will appear as black dots on the display. If any black dots appear, first ascertain it is not caused by dirt that is lodged between the display surface and the protective plastic cover. It is normal for a small number of randomly spaced pixels to not illuminate. It is not necessary to replace the display if a small number of black dots appear. They will not be visible on the normal screens displayed outside of this diagnostic mode. However, large black areas would be indicative of a defective display.

- **All Green** - This test verifies the operation of all of the green pixels. All of the green pixels are turned on to create a completely green screen. Refer to description of “All Red” test above.
- **All Blue** - This test verifies the operation of all of the blue pixels. All of the blue pixels are turned on to create a completely blue screen. Refer to description of “All Red” test above.
- **All White** - This test verifies the display’s ability to turn on all pixels to display a completely white screen. Any pixel that does not turn on will appear as a black dot. Refer to description of “All Red” test above.
- **All Black** - This test verifies the display’s ability to turn off all pixels to display a completely black screen. Any pixel that does not turn off will appear as a red, green, blue or white dot. Refer to description “All Red” test above.

BIT PATTERNS TEST SCREEN

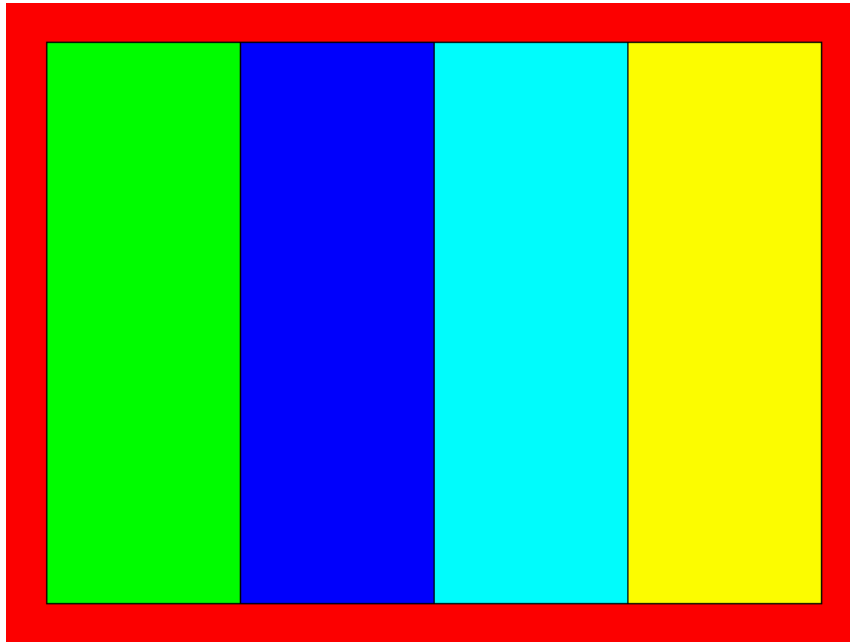

FIG. 51

00529VIPC

TROUBLESHOOTING

If any of the above tests do not perform correctly as described above, perform the applicable procedure below:

Test Failed:

Bit Patterns - If the vertical bars are not straight or if the red border is not completely visible, either the Microboard Program Jumpers are not configured correctly or for the installed Display or the Microboard is defective.

All Red, All Green, All Blue, All White or All Black:

If these tests do not produce appropriate solid color screens, the Display Ribbon Cable, Display Interface Board, Microboard or Display could be defective. To locate the defective component perform tests in the following order:

1. **Display Ribbon Cable:**

Using an Ohmmeter, perform a continuity test on all conductors in the ribbon cable. An open circuit would indicate the ribbon cable is defective.

2. **Display Interface Board:**

Using an Ohmmeter, perform a continuity test on all conductors of the Interface Board. An open circuit would indicate the Interface Board is defective.

3. **Microboard:**

- a. With the “All Red” test selected, the voltage at Microboard J5-6 through J5-11 (Red drivers bits 0-5), as measured to Gnd, should be $> 3.0\text{VDC}$. If not, the Microboard is defective.
- b. With the “All Green” test selected, the voltage at Microboard J5-13 through J5-18 (Green drivers bits 0-5), as measured to Gnd, should be $> 3.0\text{VDC}$. If not, the Microboard is defective.
- c. With the “All Blue” test selected, the voltage at Microboard J5-20 through J5-25 (Blue drivers bits 0-5), as measured to Grid, should be $> 3.0\text{VDC}$. If not, the Microboard is defective.
- d. With the “All White” test selected, the voltage at Microboard J5-6 through J5-11, J5-13 through J5-18 and J5-20 through J5-25 should be $> 3.0\text{VDC}$. If not, the Microboard is defective.
- e. With “All Black” selected, the voltage at Microboard J5-6 through J5-11, J5-13 through J5-18 and J5-20 through J5-25 should be $< 1.0\text{VDC}$. If not, the Microboard is defective.

4. **Display:**

If the Display Ribbon Cable, Display Interface Board and Microboard check OK per the above procedures, the Display is most likely the cause of the problem.

SERIAL INPUTS / OUTPUTS TESTS

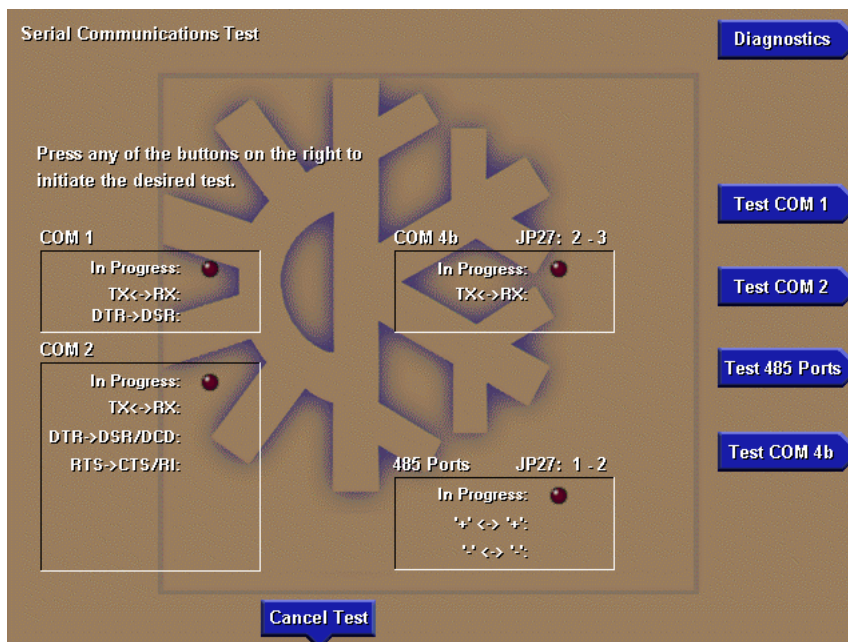

FIG. 52

00530VIPC

This diagnostic is used to verify correct operation of the Serial Data Ports. There is a test for each of the five Serial Data Ports. Each RS-232 port (COM 1, 2 and 4b) is tested by transmitting serial test data from outputs to inputs of each port. Both the transmit and receive functions as well as the control lines are tested. The RS-485 ports (COM 3 and 4a) are tested by transmitting serial test data from one RS-485 port to another. The TX/RX opto-coupled port (COM 5) is tested by transmitting serial test data from the TX output to the RX input. If the received data matches the transmitted data, PASS is displayed, indicating the serial port is OK. Otherwise, FAIL is displayed, indicating the serial port is defective. Prior to performing each test, the Service Technician must install a wire loop-back connection as described below. Refer to Section 5 and Figure 35 of this book for description of the Serial data Ports.

PROCEDURE

- Using small gauge wire, fabricate loop-back connections and install as follows for each port to be tested. Failure to install the loop-back connection or configure the Microboard Program jumper as noted will result in a FAIL outcome for the test.

	From	To
COM 1	J2-4 (TX)	J2-3 (RX)
	J2-5 (DTR)	J2-2 (DSR)

	From	To
COM 2	J13-5 (TX)	J13-3 (RX)
	J13-7 (DTR)	J13-1(DCD) & J13-2(DSR)
	J13-4 (RTS)	J13-6 (CTS) & J13-8 (RI)

	From	To
RS-485 (COM 3 & 4a)	J12-3 (+)	J11-3 (+)
	J12-2 (-)	J11-2 (-)

Microboard Program Jumper JP27 must be installed in position 1 & 2.

	From	To
COM 4b	J2-7 (GTX)	J2-6 (GRX)

Microboard Program Jumper JP27 must be installed in position 2 & 3

- After connecting appropriate loop-back connections above, press the appropriate key to initiate the desired test. An LED will illuminate indicating the test is in progress. If it is desired to terminate the test, press the CANCEL TEST key. Test data is sent from an output to an input as described below. At the completion of each test, if the data received matches the data sent, the Serial Port operates properly and PASS is displayed. Otherwise, FAIL is

displayed, indicating the Serial Port is defective. A FAIL result would be indicative of a defective Microboard. The following is a description of each test.

COM 1 – Two tests are performed. Test data is sent from TX (J2-4) to RX (J2-3) at 9600 Baud and DTR (J2-5) is set to a Logic High level and read at DSR (J2-2). If any test fails, COM 1 tests are terminated.

COM 2 – Three tests are performed. Test data is sent from TX (J13-5) to RX (J13-3) at 19200 Baud. DTR (J13-7) is set to a Logic High and read at DSR (J13-2) & DCD (J13-1). RTS (J13-4) is set to a Logic High and read at CTS (J13-6) & R1 (J13-8). If any test fails, COM 2 tests are terminated.

RS-485 (COM 3 & 4a) – Test data is sent from COM 3 RS-485 port to COM 4a RS-485 Port at 19200 Baud. Test data is then sent from COM 4a to COM 3 at the same rate. If either test fails, RS-485 tests are terminated.

COM 4b – Test data is sent from GTX (J2-7) to GRX (J2-6) at 19200 Baud.

3. After all desired tests have been performed, press the DIAGNOSTICS key to return to the MAIN DIAGNOSTICS Screen.

DIGITAL INPUTS / OUTPUTS TESTS



FIG. 53

00531VIPC

This diagnostic is used to analyze the digital inputs and outputs of the Microboard.

The state of each Microboard Program Jumper and Program DIP Switch, as interpreted by the Microboard, is depicted by an LED. If the Microboard interprets its input as being at a Logic Low (<1.0VDC) level, the LED is illuminated. If interpreted as being at a Logic High (>4.0VDC) level, the LED is extinguished.

PROCEDURE

Digital Inputs:

1. The Digital Inputs are listed on this screen according to Microboard Program Jumpers and Program DIP Switches. Tables 2 and 3 list the functions of the Program Jumpers and Switches.

2. If a Program Jumper is present, the applicable LED should be extinguished. If the LED is not extinguished, the Microboard is defective.
3. If a Program Jumper is not present, the applicable LED should be illuminated. If the LED is not illuminated, the Microboard is defective.
4. If a Program Switch (DIP) is in the ON position, the applicable LED should be illuminated. If the LED is not illuminated, the Microboard is defective.
5. If the Program Switch (DIP) is in the OFF position, the applicable LED should be extinguished. If the LED is not extinguished, the Microboard is defective.
6. When all desired tests have been performed, press DIAGNOSTICS key to return to MAIN DIAGNOSTICS Screen.

ANALOG INPUTS TESTS



FIG. 54

00532VIPC

This diagnostic is used to analyze the Analog Inputs to the Microboard. The voltage level of each Analog input, as interpreted by the Microboard, is displayed. The “Counts” listed for each parameter is the Analog-to-Digital (A/D) converter value and is for manufacturing and engineering use only.

The following is a list of the Analog inputs displayed.

Channel

- 0 - Presently Not Used.
- 1 - Presently Not Used.

SYSTEM COMMISSIONING CHECKLIST

Use the following checklist during commissioning to assure all Setpoints have been programmed to the desired value and all calibrations have been performed. The Setpoints are grouped under the Display Screen in which they appear. The indented screens are subscreens of the numbered screens and are accessed from the numbered screens. An explanation of each setpoint or Calibration Procedure below is contained in the reference document listed in parenthesis adjacent to each item. If any of the Setpoints have to be changed, use the standard programming procedures in the Operation Section. Thresholds, values and calibrations of items marked with an asterisk "*" have been determined and entered/set at the YORK Factory at the time of manufacture.

1. PROGRAM JUMPERS/SWITCHES:

____ Verify Microboard Program Jumpers and Program Switches are configured appropriately.

2. SETPOINTS Screen:

The setpoints listed on the **SETPOINTS** Screen have already been programmed at the chiller/condensing unit. The values shown reflect the previously programmed values. However, the setpoints listed here can be changed on this screen if desired only if the chiller/condensing unit is in remote control mode. This screen is used primarily as a central location from which most setpoints can be programmed. If it is not desired to change any of the listed setpoints, proceed to the following **RCC SETPOINTS** Screen.

3. RCC SETPOINTS Screen:

____ Number of Units Connected

RCC SETUP Screen:

____ Enable Clock
 ____ Enter CLOCK Time and Date
 ____ Select 12 or 24 hour display mode

COMMS Screen:

Enter the following parameters as required for communication to the remote chiller panel(s):

____ RCC Poll Time

PRINTER Screen:

If Printer is connected to Microboard serial ports, enter the following:

____ Baud rate
 ____ Number of data bits
 ____ Number of stop bits
 ____ Parity
 ____ Automatic printer logging Enable/disable
 ____ Log start time
 ____ Log output interval
 ____ Log Unit Selected (1-8, All)
 ____ Printer type

SECTION 6 – PART NUMBER AND RENEWAL PARTS

TABLE 4 - PART NUMBER

DESCRIPTION	PART NO.
COMPLETE OPTIVIEW RCC PANEL	371-02750-101

TABLE 5 - RENEWAL PARTS

ITEM	DESCRIPTION	FIG. NO.	QTY.	PART NO.
1	MICROPROCESSOR BOARD (NOTE 2)	56	1	031-01730-002
2	POWER SUPPLY ASSY	56	1	371-02750-411
3	KEYPAD	55	1	024-30974-001
4	TERMINAL BLOCK	56	1	025-35120-000
5	DISPLAY KIT (NOTE 1)	55	1	331-02053-000
6	CABLE ASSY. POWER SUPPLY	56	1	571-02750-421
7	KEYPAD TO MICRO RIBBON CABLE	56	1	031-02056-000
8	EPROM, BIOS (U45)	56	1	031-01796-001
9	FLASH MEMORY CARD, PROGRAMMED (U46)	56	1	031-02057-001
10	IC, BRAM (U52)	56	1	031-02028-000
11	FLAT CABLE FERRITE CLAMP	56	1	025-34172-000
12	SLEEVE SNAP FERRITE	56	1	025-35154-000
13	BACKLIGHT BULB	57	1	See Note 4
14	BACKLIGHT INVERTER BOARD	57	1	See Note 4
15	BACKLIGHT INVERTER BOARD RIBBON CABLE	57	1	See Note 4
16	DISPLAY INTERFACE BOARD	57	1	See Note 4
17	DISPLAY INTERFACE BOARD RIBBON CABLE	57	1	031-02055-000
18	LAN TRANSIENT PROTECTION MODULE	2	1	031-01586-000
19	TRANSIENT VOLTAGE SUPPRESSOR	2	2	031-02076-000
20	IC, RS-485 DRIVER	56	4	031-02074-000
21	FUSE, F1 & F2, 5 AMP (Rev. E and later Microboards)	58	2	025-34592-000
22	MICROGATEWAY OPTIVIEW KIT (future option)	56	1	371-03609-001
23	EPROM, MICROGATEWAY	56	1	See 450.RP1

NOTES:

1. The replacement Liquid Crystal Display supplied by YORK might not be by the same manufacturer as the original Display. Each Display requires a specific Display Interface Board (Item 16), Backlight Inverter Board (Item 14), and Backlight Inverter Board ribbon cable (Item 15). Therefore, the Liquid Crystal Display is not available separately. Service replacement Displays or supporting components must not be arbitrarily selected! Non-compatibility of components will result in incorrect operation! To assure compatible supporting components, the Display is supplied as a kit (part number 331-02053-000), which contains a replacement Display and all compatible supporting components on a mounting plate. For future reference, a label attached to the side of the mounting plate (Fig. 57) lists the YORK part numbers of these compatible components and the required configuration of the Microboard Program Jumpers. These Program Jumpers must be configured for this Display by a qualified Service Technician following instructions in this manual. The contents of the kit are as follows:
 - a. Liquid Crystal Display
 - b. Backlight Bulb (Item 13)
 - c. Appropriate Display Interface Board (Item 16) for Display
 - d. Appropriate Display Interface Board ribbon cable (Item 17) for Item 16.
 - e. Appropriate Backlight Inverter Board (Item 14) for Display.
 - f. Appropriate Backlight Inverter Board ribbon cable (Item 15) for Item 14.
 - g. All mounting hardware.
 - h. Installation instructions.
2. Replacement Microboards are shipped without Flash Memory Cards (U46) or BRAM (U52). Remove these devices from defective Board and use them in replacement Board. If a new Eprom, Flash Memory Card or BRAM is required, refer to the previous table for part number. Return all unused Flash Memory Cards with Warranty return boards.
3. Ferrites are shipped in cloth bag. They are applied to the chiller communication RS-485 cable and the MicroGateway LAN cable prior to exiting the Remote Control Center enclosure.
4. Refer to label (Fig. 57) on Display mounting plate for YORK part number of applicable replacement part. Service replacement Display supporting components must not be arbitrarily selected! Non-compatibility of components will result in incorrect operation!

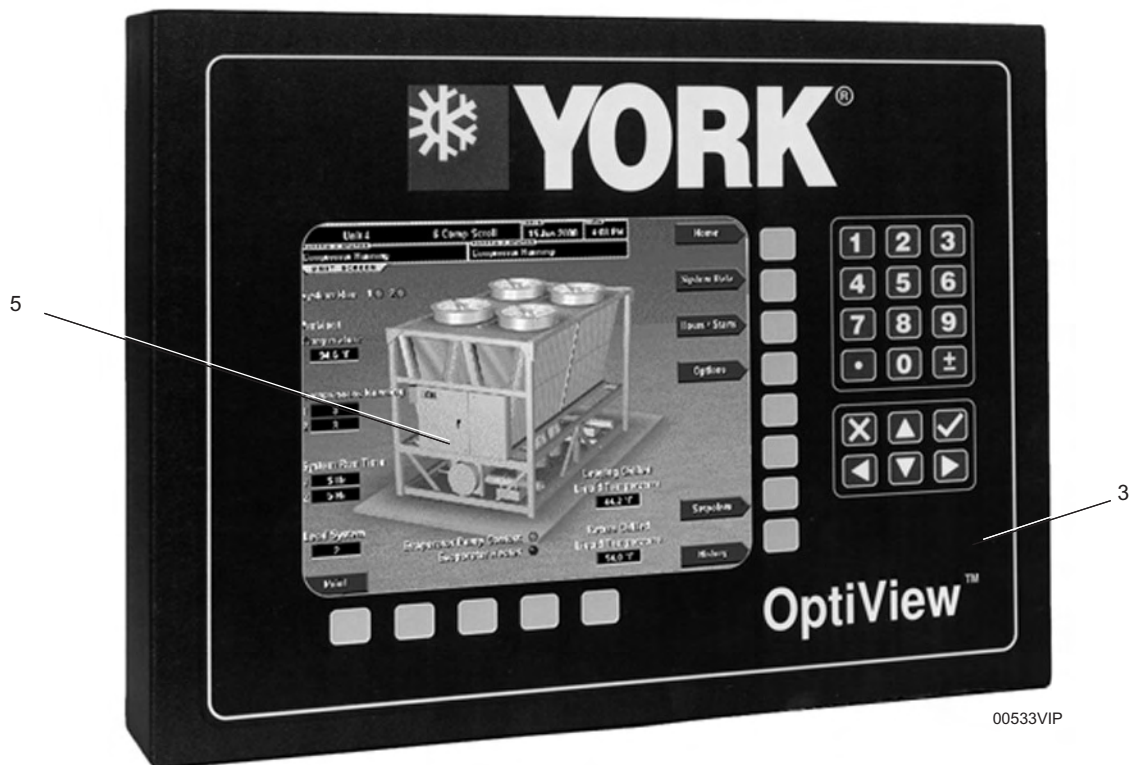

FIG. 55 – FRONT OF OPTIVIEW REMOTE CONTROL CENTER

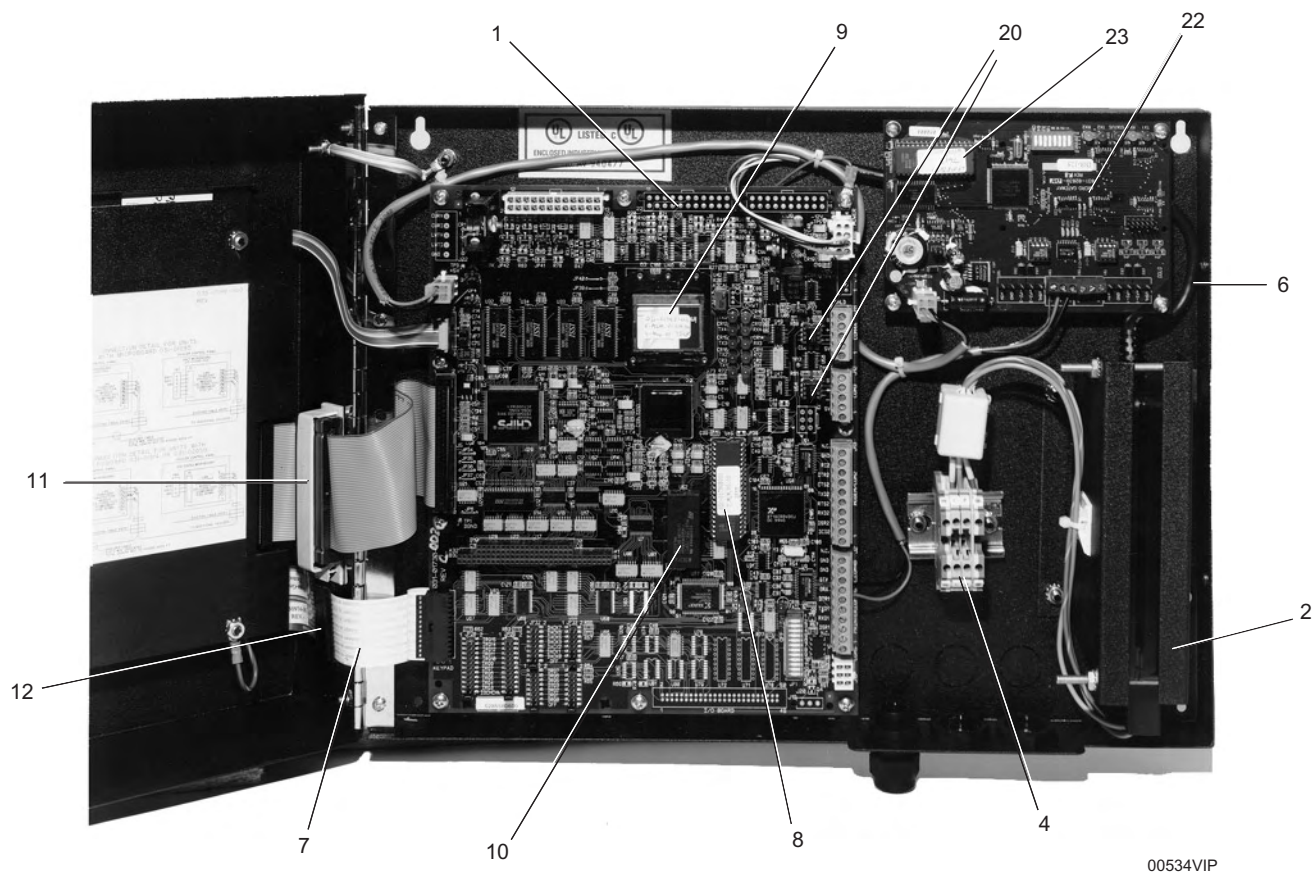

FIG. 56 – INSIDE OF OPTIVIEW REMOTE CONTROL CENTER

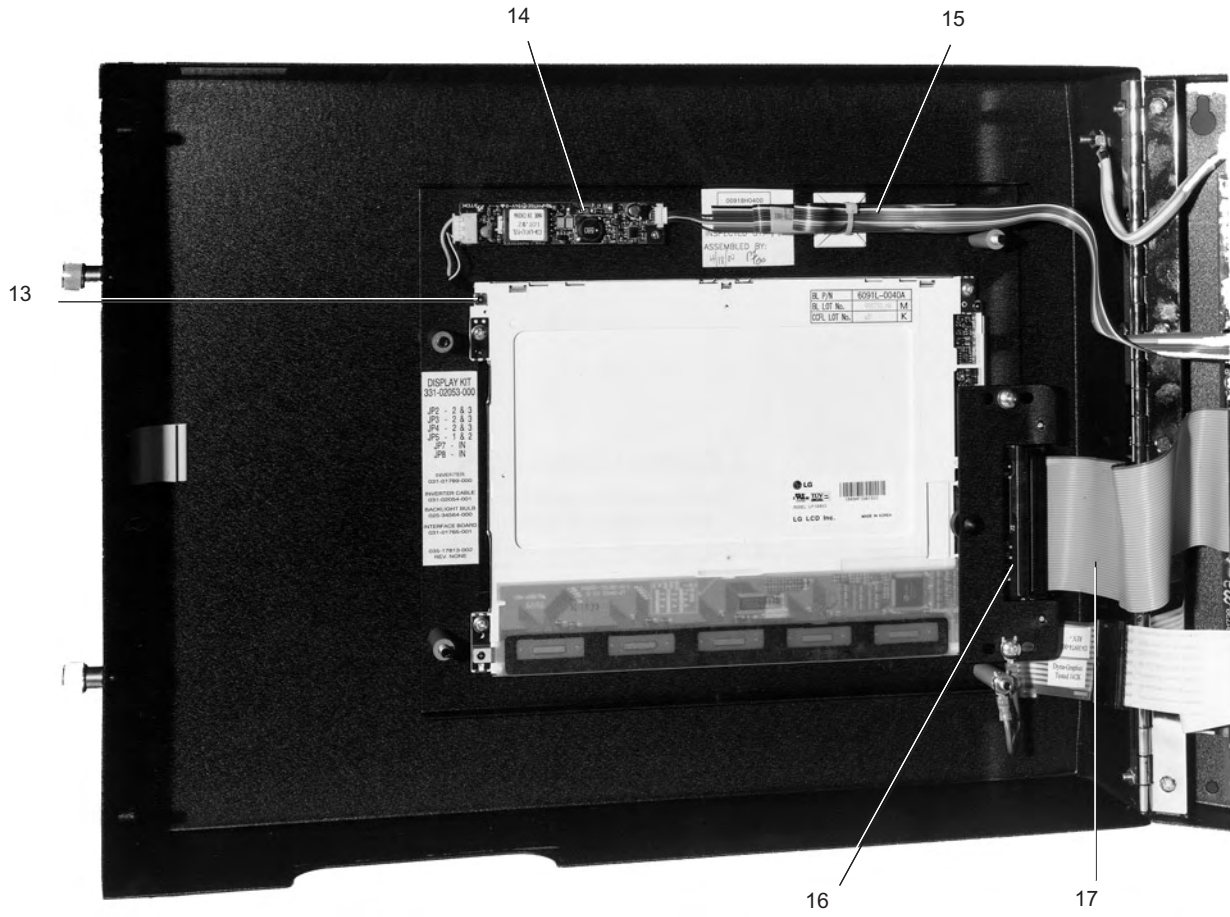
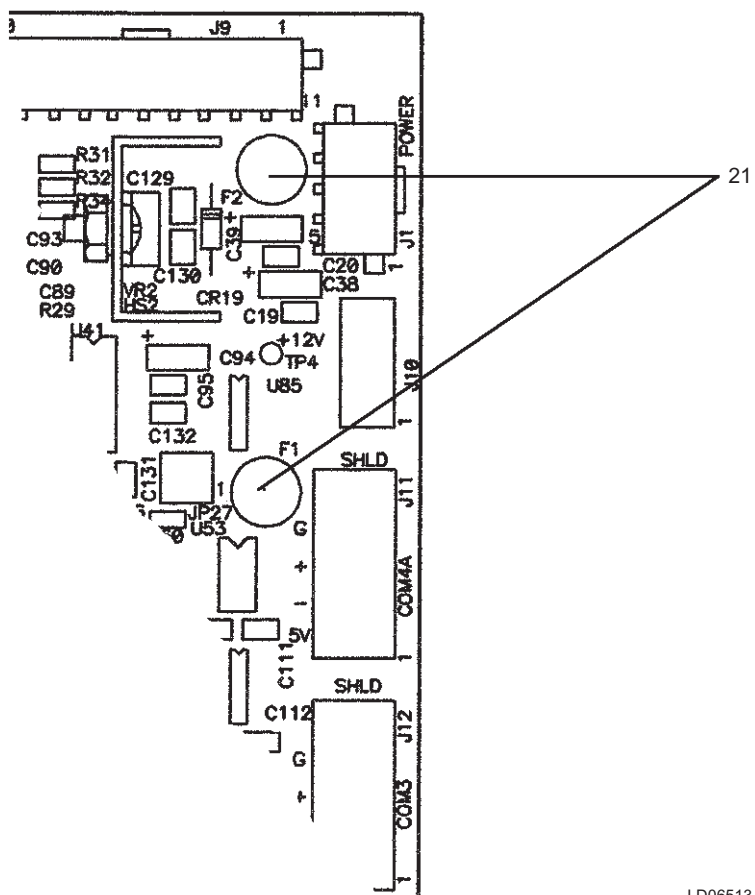

FIG. 57 – INSIDE DOOR OF OPTIVIEW REMOTE CONTROL CENTER

00535VIP



LD06513

FIG. 58 – LOCATION OF FUSE, F1 & F2

SI METRIC CONVERSION

The following factors can be used to convert from English to the most common SI Metric values.

MEASUREMENT	MULTIPLY THIS ENGLISH VALUE	BY	TO OBTAIN THIS METRIC VALUE
CAPACITY	TONS REFRIGERANT EFFECT (ton)	3,516	KILOWATTS (kW)
POWER	KILOWATTS (kW)	NO CHANGE	KILOWATTS (kW)
HORSEPOWER (hp)	0.7457	KILOWATTS (kW)	
FLOW RATE	GALLONS/MINUTE (gpm)	0.0631	LITERS/SECOND (l/s)
LENGTH	FEET (ft)	304.8	MILLIMETERS (mm)
	INCHES (in.)	25.4	MILLIMETERS (mm)
WEIGHT	POUNDS (lb.)	0.4536	KILOGRAMS (kg)
VELOCITY	FEET/SECOND (fps)	0.3048	METERS/SECOND (m/s)
PRESSURE DROP	FEET OF WATER (ft)	2.989	KILOPASCALS (kPa)
	POUNDS/SQ. INCH (psi)	6.895	KILOPASCALS (kPa)

TEMPERATURE

To convert degrees Fahrenheit (°F) to degrees Celsius (°C), subtract 32° and multiply by 5/9 or 0.5556.

To convert a temperature range (i.e. 10°F or 12°F chilled water range) from Fahrenheit to Celsius, multiply by 5/9 or 0.5556.



Proud Sponsor
of the 2002
U.S. Olympic Team

36USC380