



**BACnet MS/TP
MICROGATEWAY**

INSTALLATION MANUAL

Supersedes 450.20-N14 (1203)

Form 450.20-N14 (905)

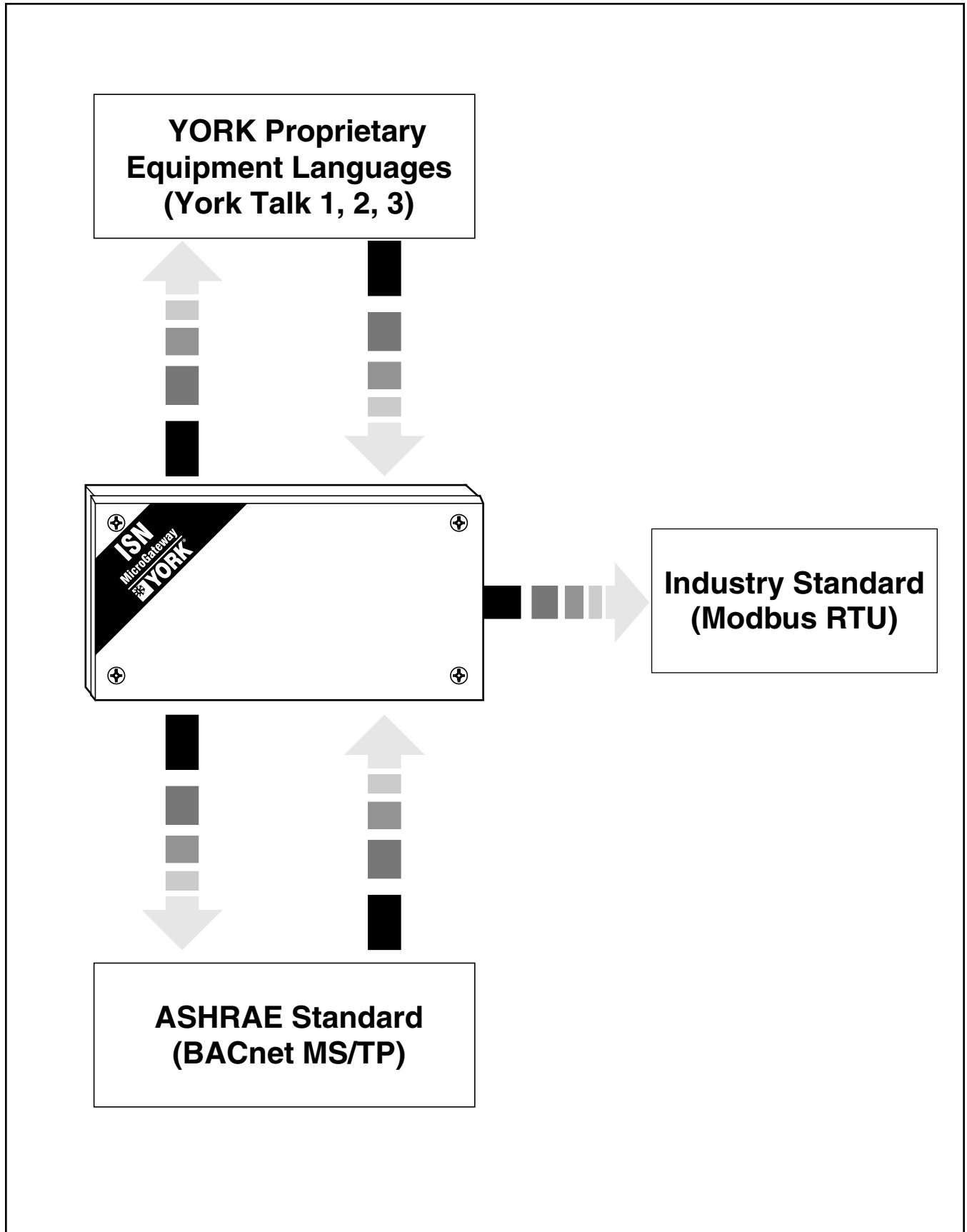

IMPORTANT!

READ BEFORE PROCEEDING!

GENERAL SAFETY GUIDELINES

This equipment is a relatively complicated apparatus. During installation, operation, maintenance or service, individuals may be exposed to certain components or conditions including, but not limited to: refrigerants, oils, materials under pressure, rotating components, and both high and low voltage. Each of these items has the potential, if misused or handled improperly, to cause bodily injury or death. It is the obligation and responsibility of operating/service personnel to identify and recognize these inherent hazards, protect themselves, and proceed safely in completing their tasks. Failure to comply with any of these requirements could result in serious damage to the equipment and the property in which it is situated,

as well as severe personal injury or death to themselves and people at the site.

This document is intended for use by owner-authorized operating/service personnel. It is expected that this individual possesses independent training that will enable them to perform their assigned tasks properly and safely. It is essential that, prior to performing any task on this equipment, this individual shall have read and understood this document and any referenced materials. This individual shall also be familiar with and comply with all applicable governmental standards and regulations pertaining to the task in question.

SAFETY SYMBOLS

The following symbols are used in this document to alert the reader to areas of potential hazard:



DANGER indicates an imminently hazardous situation which, if not avoided, will result in death or serious injury.

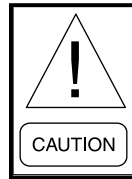

CAUTION identifies a hazard which could lead to damage to the machine, damage to other equipment and/or environmental pollution. Usually an instruction will be given, together with a brief explanation.



WARNING indicates a potentially hazardous situation which, if not avoided, could result in death or serious injury.

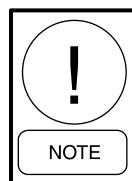

NOTE is used to highlight additional information which may be helpful to you.

CHANGEABILITY OF THIS DOCUMENT

In complying with YORK's policy for continuous product improvement, the information contained in this document is subject to change without notice. While YORK makes no commitment to update or provide current information automatically to the manual owner, that information, if applicable, can be obtained by contacting the nearest YORK Engineered Systems Group office.

It is the responsibility of operating/service personnel as to the applicability of these documents. If there is any question in the mind of operating/service personnel as to the applicability of these documents, then, prior to working on the equipment, they should verify with the owner whether the equipment has been modified and if current documentation is available.

SUMMARY OF CHANGES

- 501 Original Release
- 1203 Included information from Literature Supplements, including terminal label fixes and additional Quick Start information.
Included remote monitoring option and additional part numbers.
Modified to connection drawings for ease of use.
- 905 Corrected 3rd Party Connection on Figures 7, 14, 19, 20, and 21
Updated Table 3 – Cable Requirements

REFERENCE INSTRUCTIONS

DESCRIPTION	FORM NO.
BACnet MS/TP MicroGateway Specification	450.20-S24
BACnet MS/TP MicroGateway Operation	450.20-O4
BACnet MS/TP MicroGateway PICs/BIBBs Statement	450.20-TD01
Renewal Parts List	450.00-RP1

TABLE OF CONTENTS

GENERAL SAFETY GUIDELINES.....	2
CHANGEABILITY OF THIS DOCUMENT	3
FIGURE LIST	6
TABLE LIST	6
SECTION 1 – GENERAL INFORMATION.....	7
Overview.....	7
Quick Start.....	7
CLIP.....	9
SECTION 2 – NETWORK TOPOLOGY	11
SECTION 3 – INSTALLATION.....	15
Installation Guidelines	15
Environment.....	15
Power.....	15
Grounding	16
High Noise Environments	16
Termination	17
Protection of Communication Ports	17
Cable Specifications	17
Power Cables.....	17
Network Cables	17
User Selections	18
Setting the Rotary Switch	18
MicroGateway Jumpers	18
OptiView Installation	19
Other Chiller Panels.....	21
Mounting on a Micro Panel	21
Wall Mounting	23
Connecting Power.....	24
Connecting the Communications Wiring.....	25
CLIP Communication.....	25

CONTENTS (continued)

SECTION 4 – COMMISSIONING.....	37
Default Settings	37
How to Use the Node Switch	37
Setting the Network Address	38
Quick Start.....	38
York Talk Points List	38
Selecting a Quick Start Address.....	39
Quick Start 128.....	39
Sign-Off	39

FIGURE LIST

Figure 1. MicroGateway OptiView Kit Components	8
Figure 2. Typical Board Topology	11
Figure 3. Typical Board Topology	12
Figure 4. Typical Board Topology	13
Figure 5. Additional Ground Conductor	16
Figure 6. OptiView Mounting	19
Figure 7. OptiView Connections	20
Figure 8. Non-OptiView Enclosure Mounting.....	22
Figure 9. Wall Mounting	23
Figure 10. Typical Power Connections for Close-Coupled MicroGateway	24
Figure 11. 776 Board Connections	26
Figure 12. 940 Board Connections	27
Figure 13. 1065 Board Connections	28
Figure 14. 1095 Master Board Connections	29
Figure 15. 1095 Master/Slave Board Connections	30
Figure 16. 1095 to 1793 Board Connections	31
Figure 17. 1314 Board Connections	32
Figure 18. 2050 Board Connections	33
Figure 19. Frick Quantum 1 and 2 Board Connections.....	34
Figure 20. Frick Quantum 3 Board Connections.....	35
Figure 21. Frick RWB II Board Connections	36
Figure 22. Setting the Node Switch	37
Figure 23. Commissioning Sequence.....	40

TABLE LIST

Table 1 – MicroGateway Options	7
Table 2 – MicroGateway Communication Ports	11
Table 3 – Cable Requirements	18
Table 4 – OptiView Wiring (Port 1).....	19
Table 5 – BACnet Wiring (Port 2).....	19
Table 6 – Default Settings.....	37
Table 7 – Quick Start Chiller Profiles	41
Table 8 – Quick Start Auxiliary Functions	42

SECTION 1

GENERAL INFORMATION

Overview

The BACnet MS/TP MicroGateway is a communications device that allows any YORK chiller that supports one of the three York Talk protocols to be connected to a BACnet® network using the BACnet MS/TP protocol.

There are several variations of the BACnet MS/TP MicroGateway, depending upon the type of input voltage and the chiller with which it will be connected to. A clip-on board (CLIP) is available as an option to allow monitoring by a remote Modbus host. The BACnet MS/TP MicroGateway can be ordered with or without the CLIP.

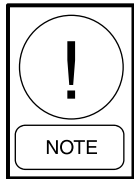

NOTE: Throughout this manual, the CLIP refers to the clip-on board with the third port. Reference to the MicroGateway always refers to the 031-02039-xxx circuit board and may or may not include the CLIP and power supply.

For chillers using the OptiView micro panel, the MicroGateway consists of a single circuit board which is attached to four studs inside the micro panel. The 12 volt DC input power is drawn directly from the OptiView panel, eliminating the need for an external power supply.

For other types of chillers, the MicroGateway comes with its own enclosure. In addition to the MicroGateway circuit board, a 12 VDC power supply is included with the enclosure to convert input AC power (115 or 230 volts) to 12 volt DC power.

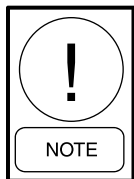

NOTE: The CLIP fits within this enclosure.

A series of LEDs provide information about the MicroGateway's communication and operating status. Each of the two ports have a red transmission LED (TX) and a green receiving LED (RX). Between the two sets of port LED's is a STATUS LED. The STATUS LED provides information to verify proper

setup selection, as well as indications of normal operation versus error modes.

Table 1 – MicroGateway Options

PN	INPUT VOLTAGE	TYPE
371-03609-005*	12 VDC	OptiView Kit
371-03609-015*	12 VDC	OptiView Kit w/CLIP
371-02592-105	115 VAC	Enclosure
371-02592-115	115 VAC	Enclosure w/ CLIP
371-02592-205	230 VAC	Enclosure
371-02592-225	230 VAC	Enclosure w/ CLIP

* Includes MicroGateway board, power cable, chiller interface cable and OptiView mounting hardware.

This document is designed to provide quick and easy instructions to help in the installation and commissioning of a BACnet MS/TP MicroGateway. Mounting and wiring of the unit is covered for all types of chillers, as well as some standard setup configurations. Additional information can be found in the *Operation Manual*.

Quick Start

This manual provides instructions for setup of the BACnet MS/TP MicroGateway using the Quick Start feature only. The Quick Start feature can be used when connecting to YORK chillers using York Talk 1, 2 or 3 protocols. York Talk is the protocol available at the control panel.

- York Talk 3 – Used with OptiView panels.
- York Talk 2 – Used on micro panels after 1991.
- York Talk 1 – Used on micro panels between 1985 and 1991. Early micro panels were not capable of communications. Contact the YORK Service Group to upgrade the processor board, if necessary.

Any deviations from these standard models requires the use of more advanced techniques, a portable computer, reference to the *Operation Manual* as

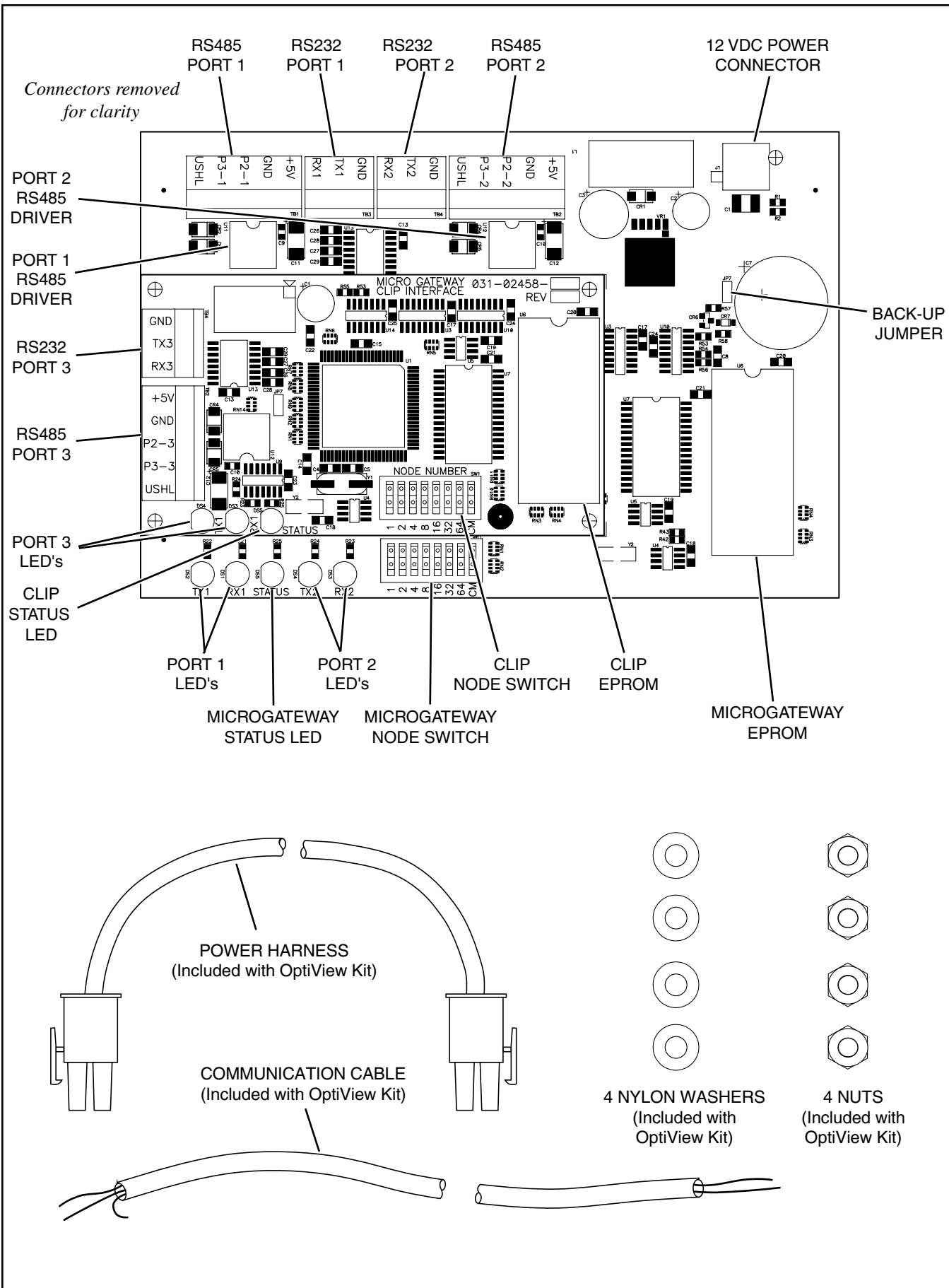

Figure 1. MicroGateway OptiView Kit Components

well as a good understanding of the communications protocols used with YORK chiller controllers. A list of the circuit board numbers and York Talk protocol is available on the YORK Controls Group website at

<http://intranet.york.com/web0147/>

The Quick Start feature uses the node switch on the MicroGateway to select the appropriate configuration for the given type of chiller based on a standard set of parameters. (Any of these parameters may be changed at the discretion of the technician. Refer to the *Operation Manual*.) This allows simple setup without the use of a portable computer and knowledge of the ISN programming language.

The Quick Start feature also provides the ability for some auxiliary functions, such as changing the OptiView micro panel's engineering units to either imperial or metric, selecting a terminal (text) interface, and performing a basic communications "loop back" test.

CLIP

MicroGateways can be ordered with or without a CLIP. The CLIP provides a third port, allowing any MicroGateway to operate as a Modbus Server, provided it uses a standard Quick Start setup.

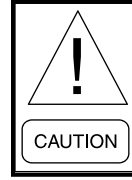

CAUTION: The procedure for setting the CLIP requires the use of the Quick Starts. If the MicroGateway is intended for customized programming beyond the scope of the Quick Start features, the Modbus Server functionality of the CLIP is overridden.

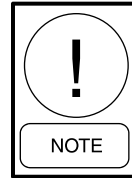

NOTE: The CLIP board cannot be field-installed on any MicroGateway. Installation requires replacement of the MicroGateway and CLIP as an assembly.

In the case of the BACnet MS/TP MicroGateway, inclusion of the CLIP provides three ports: Port 1, located on the MicroGateway circuit board, communicates to the chiller using York Talk; Port 2, located on the MicroGateway circuit board, provides full BACnet MS/TP communication capability. Port 3, located on the CLIP, provides Modbus RTU read-only capability for the monitoring of chiller data. The CLIP does not allow any write functions, ignoring any that may be received.

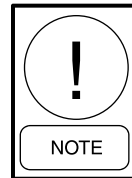

NOTE: Information regarding the collection of Modbus RTU data is a function of the remote monitoring system and is outside the scope of this manual.

THIS PAGE INTENTIONALLY LEFT BLANK

SECTION 2

NETWORK TOPOLOGY

The MicroGateway essentially consists of two serial communications ports (plus a third port for the CLIP). Port 1 and Port 2 may each be used for either RS232 or RS485 operation. A connection to the appropriate set of terminals is used to make this selection (refer to Table 2).

Port 1 is always used to connect to the chiller panel, while Port 2 can connect to either the BACnet MS/TP network or a VT100 terminal.

There is always a one-to-one relationship between the BACnet MS/TP MicroGateway and the chiller micro panel. Each MicroGateway can communicate to one, and only one, micro panel. Two chillers require two MicroGateways, etc.

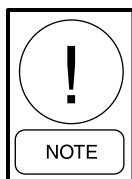

NOTE: Only one MicroGateway is required on chillers that make use of a master/slave panel arrangement.

The BACnet network uses RS485 as the transport layer and may support multiple MicroGateway units, as well as other BACnet devices. This network configuration allows multiple pieces of equipment to be integrated together into one system.

The RS485 standard limits networks to 4000 ft. (1.2 km) and 32 nodes without a repeater. York always recommends using a termination resistors.

Table 2 – MicroGateway Communication Ports

LABEL	PORT	PROTOCOL
TB1	1	RS485
TB2	2	RS485
TB3	1	RS232
TB4	2	RS232

The following illustrations show how the BACnet MS/TP MicroGateway can be incorporated into a network to allow communication between a YORK chiller and a BACnet device.

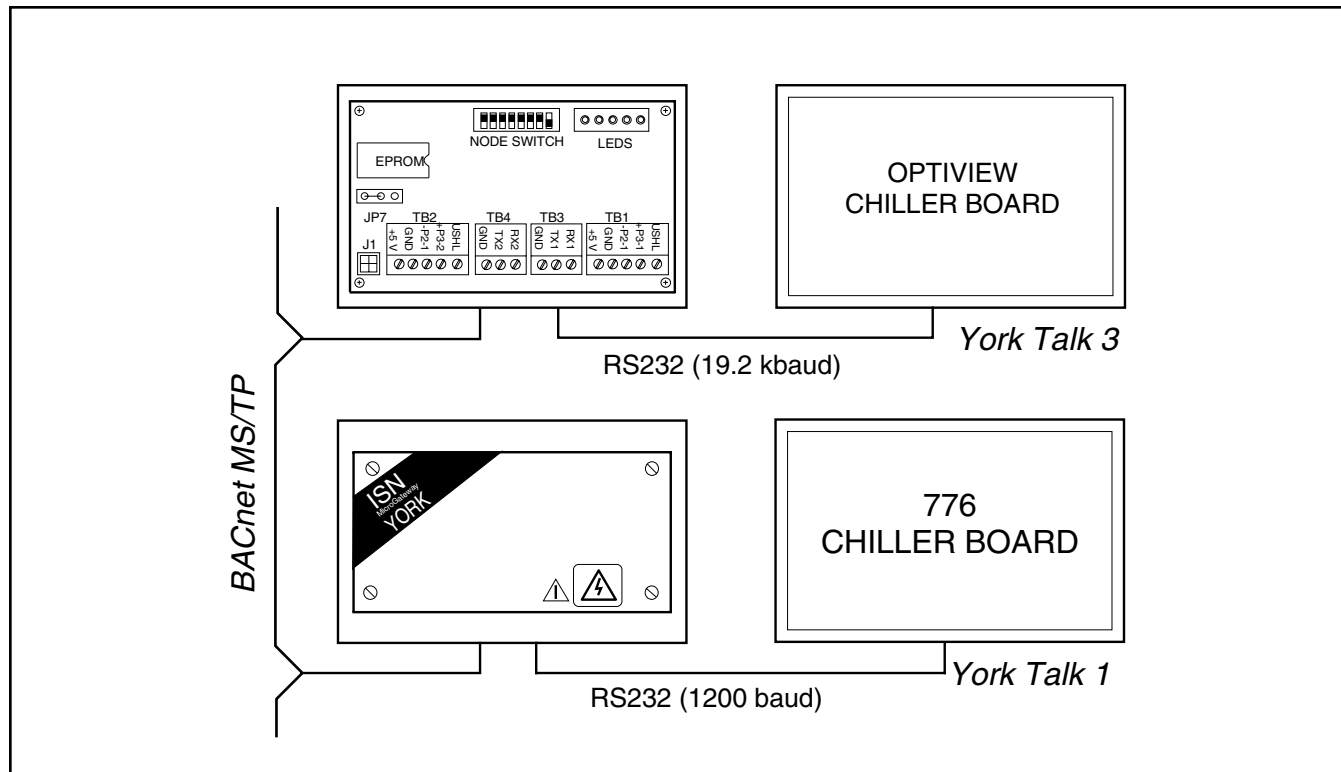

Figure 2. Typical Board Topology

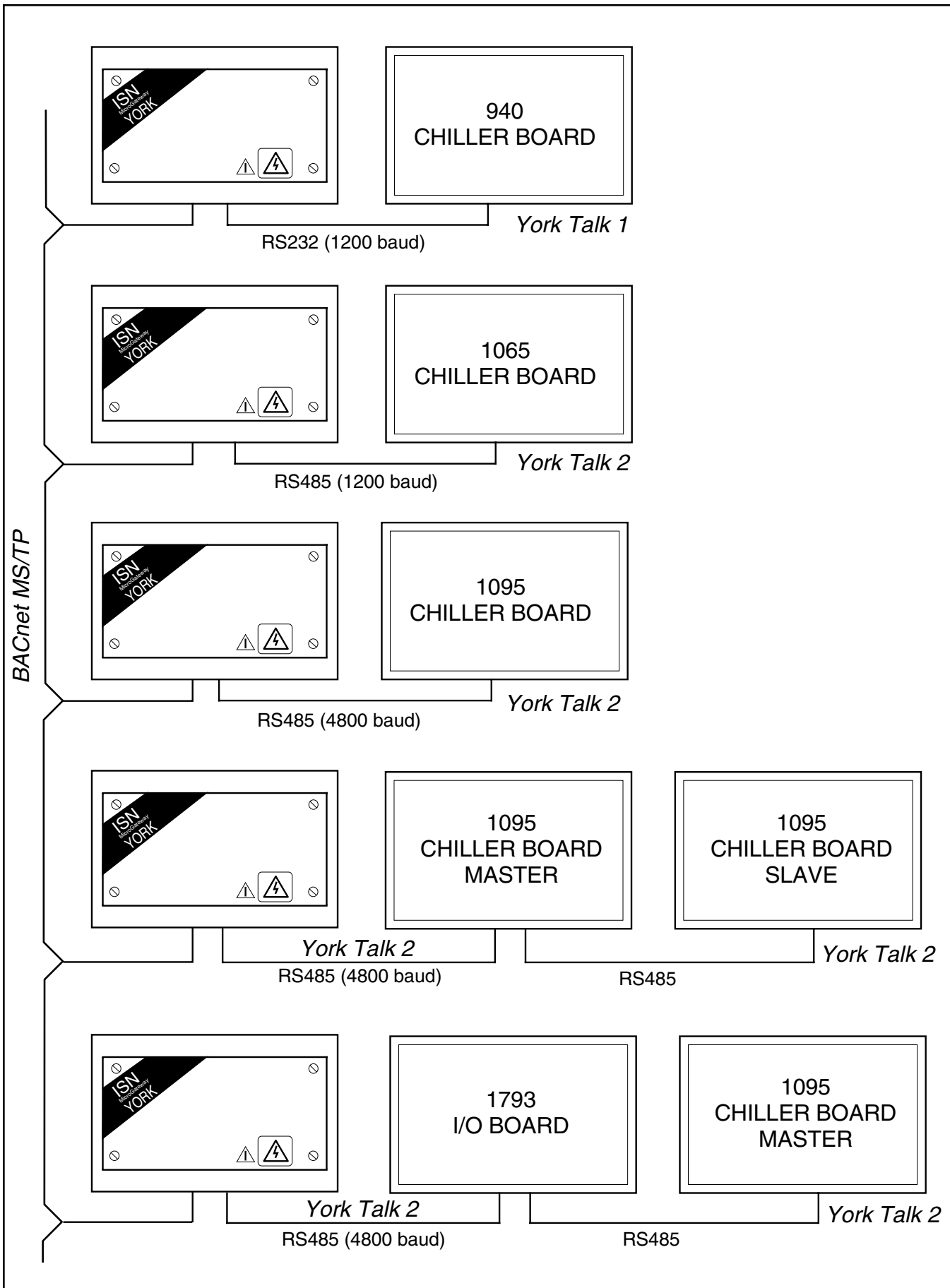

Figure 3. Typical Board Topology

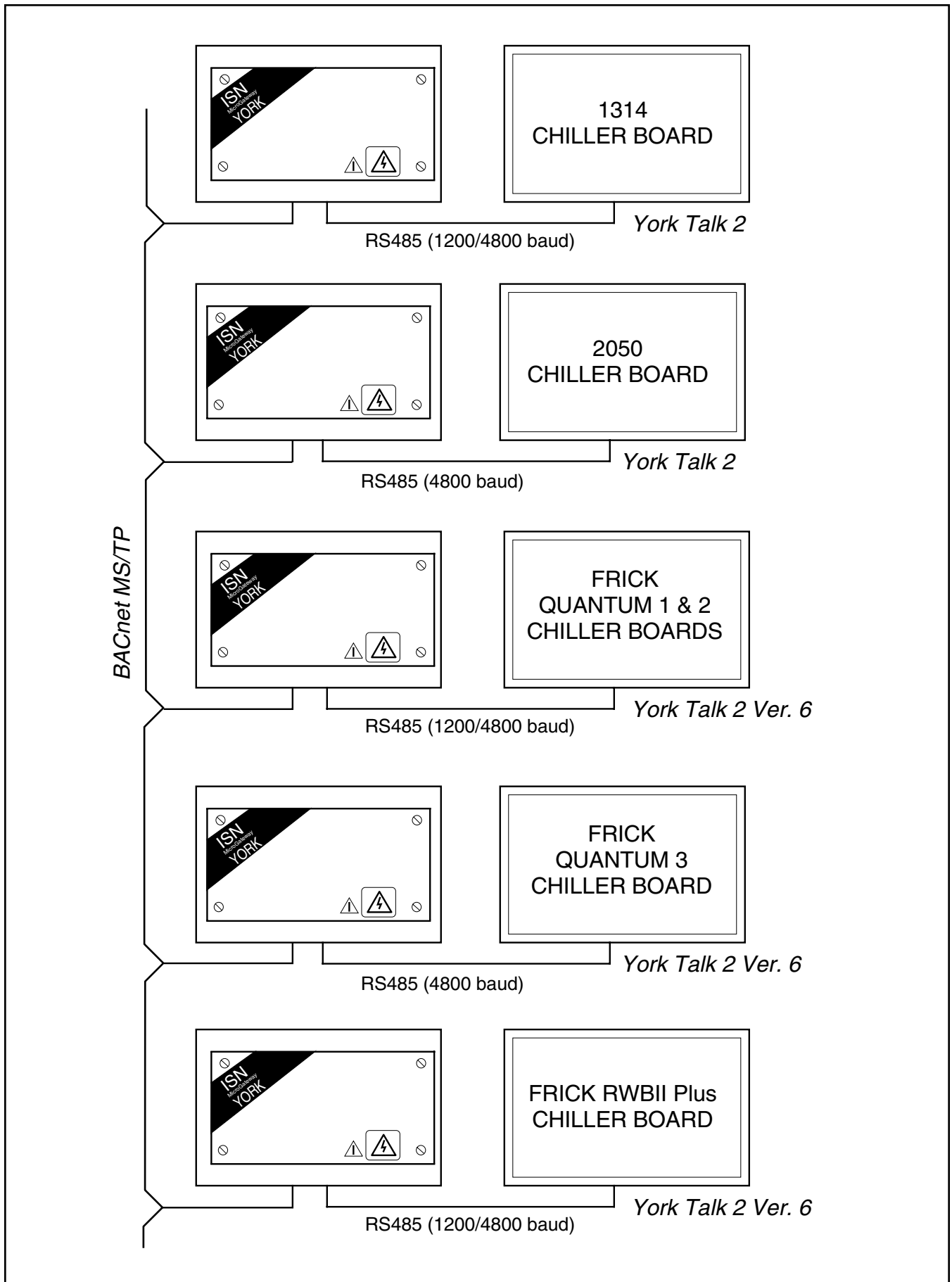

Figure 4. Typical Board Topology

THIS PAGE INTENTIONALLY LEFT BLANK

SECTION 3

INSTALLATION

Installation Guidelines

This manual assumes the installer is competent in environments with moving machinery, and is able to recognize and protect against any inherent hazards, such as, but not limited to, refrigerants, oil, materials under pressure, rotating parts, and both high and low voltages. Each of these items has the potential, if misused or handled improperly, to cause bodily injury or death.

It is the obligation and responsibility of the operating/service personnel to identify and recognize inherent hazards, protect themselves, and proceed safely in completing their tasks. Failure to comply with any of these requirements could result in serious damage to the equipment, as well as severe personal injury or death. In addition to following standard local, state and country codes and procedures, it is recommended that a lockout procedure be used to prevent inadvertent start up of equipment during installation and maintenance procedures.

All wiring should be carried out in a safe and neat manner and should always comply in all respects to the latest edition of any local, state or country codes that may be applicable. The wiring should be installed in a manner that does not cause a hazard and is protected against electrical and mechanical damage.

Environment

The MicroGateway must be installed in an environment that is protected from the direct influence of the elements and is within the following:

Temperature: 32 to 122° F (0 to 50° C).

Humidity: 0% to 95% non-condensing.

The MicroGateway should never be mounted outside the confines of a building. If this cannot be avoided, it may be mounted inside an enclosure rated at IP65/NEMA 4X or greater. In addition to protection against the elements, the enclosure must be capable of maintaining the circuit boards at the required temperature and humidity. This may require the addition of a fan or heater to maintain the temperature and humidity inside the enclosure.

Some micro panels, such as the OptiView, provide a mounting location for the MicroGateway circuit board. These micro panels also provide a power supply for the MicroGateway and utilize a different part number, which does not include a separate power supply. Refer to the documentation included with the chiller.

Care should be taken when mounting the MicroGateway so as not to impede access to other equipment within the vicinity.

Power

The MicroGateway circuit board is powered from a 12 volt DC supply. When used with an OptiView, this voltage is obtained directly from the micro panel through a power harness supplied with the kit.

If the MicroGateway circuit board is installed in its own enclosure, a power supply board is included in the enclosure. Line voltage may be supplied using an external power source or drawn from the input voltage terminal strip inside the chiller micro panel, which is recommended. On all 115 VAC micro panels, the line wire is connected to terminal L and the neutral wire connected to terminal 2. A ground strip or ground points are also located within the micro panel to ensure a common ground. For other micro panels, refer to the chiller documentation.

Be sure the VA capacity of the line supplying the chiller micro panel is rated sufficiently for the additional power required by the MicroGateway.

Use a suitably-sized wire (refer to the table titled “Recommended Cable Specifications”) to connect the line voltage feed to the MicroGateway. The line voltage power source should be “clean”, separately fused (for either 115 or 230 VAC), and isolated, (using a control transformer) from other equipment in the plant room that may generate EMI interference.

All high voltage wiring (>75 volts) must be run in conduit and kept separate from low voltage communications wiring. This will greatly reduce network communication problems.

Grounding

For the enclosure style of MicroGateway a ground wire must be connected directly to the chassis at the point of entry. This ensures that the enclosure remains grounded when the power plug is removed.

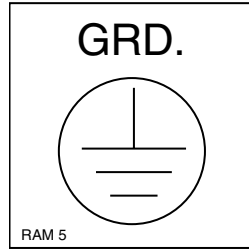

There is a small label that identifies the ground point. This should be connected through a continuous ground circuit to the incoming ground at the source transformer.

High Noise Environments

Electrical equipment which employs high speed switching circuits (variable speed drives, solid state starters and computing equipment) generate Electro-Magnetic Noise (EMI) and Radio Frequency Interference (RFI). When excessive, this noise can effect the way electronics behave and, ultimately, effect communication.

Noisy environments often show up as varying ground potentials, i.e. the electrical reference points at different nodes are different. This is referred to as “common mode” noise. The RS485 circuitry is designed to withstand a certain difference between varying ground sources. However, if this difference becomes too great and exceeds certain voltage limits, the RS485 circuitry can be permanently damaged and require replacement.

To combat these possible problems follow good wiring practices:

- Care should be taken to ensure that the micro panel and MicroGateway are powered from a source with true earth ground.
- The communication cable should be shielded with the shield terminated at one end only.
- Communication cables should not be run in close proximity to or parallel with power cables.

The pathways for noise, and therefore the likelihood of common mode noise, are greatly reduced if the MicroGateway is close-coupled to the micro panel (as shown in Figure 10). Close-coupling requires that

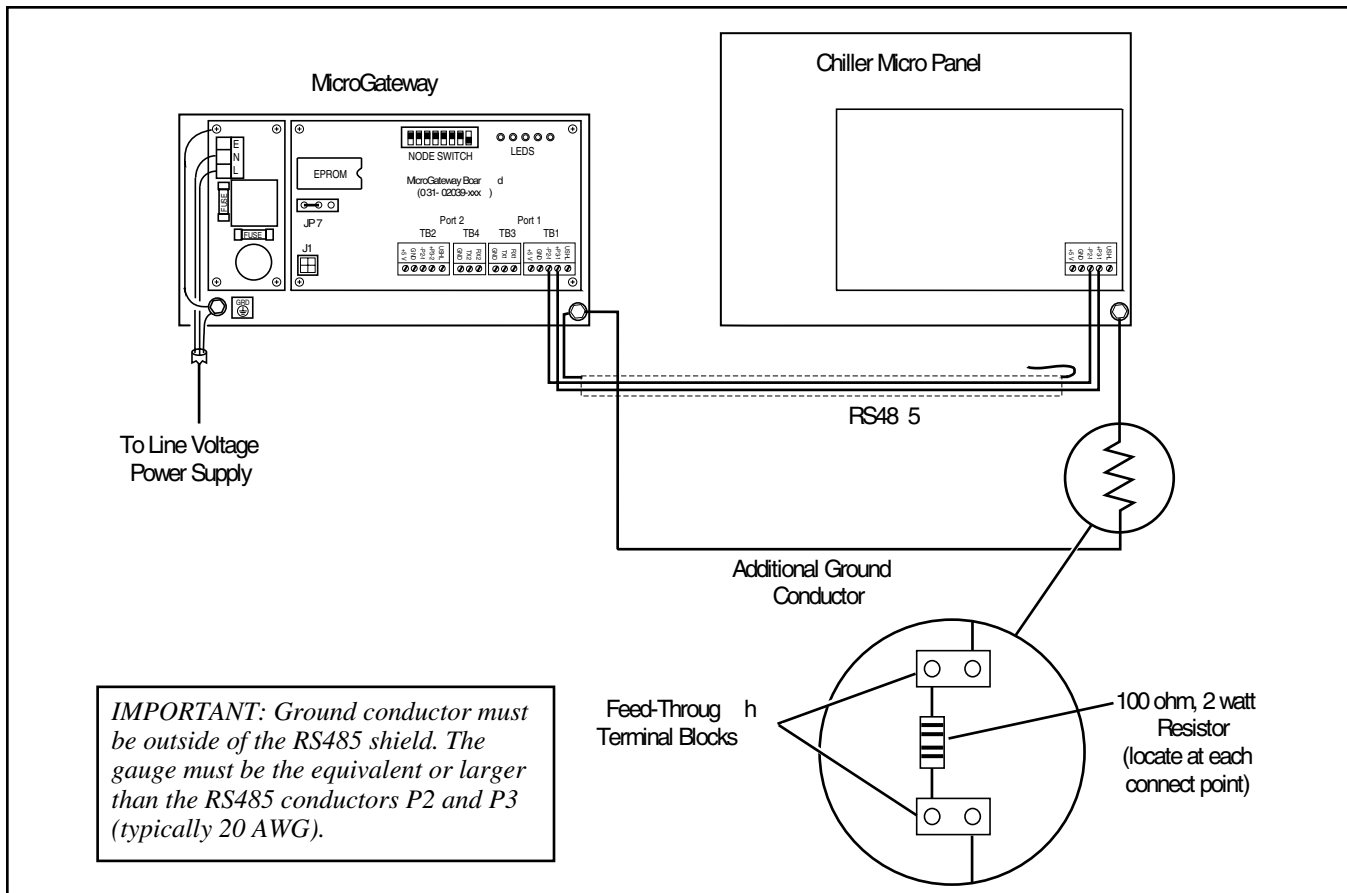

Figure 5. Additional Ground Conductor

the MicroGateway and micro panel share the same line voltage power source and are physically close to one another. Typically the MicroGateway is mounted on the micro panel enclosure. This ensures a short communication cable which is usually protected entirely within the two enclosures.

The RS485 standard requires three conductors when connecting network nodes together; 2 signal wires and a signal return path. YORK has typically used a twisted-pair cable for the signal wires with the building infrastructure (ground) functioning as the return path.

When an application requires the MicroGateway to be mounted remotely from the micro panel and the line voltage power supply is obtained from a different location, the building grounds may not be at the same potential due to the coupling of electrical noise. In these situations, a separate conductor (outside the shield) should always be run alongside the standard twisted-pair cable in case there are communication problems. This avoids future installation costs should an additional conductor be required to address communication problems. If communication problems do occur, the additional conductor can be connected to equalize the ground potential. If communication operates as expected, the additional conductor is not connected and the building infrastructure operates as the signal return path.



CAUTION: Do not connect the additional conductor unless communication problems have been verified.

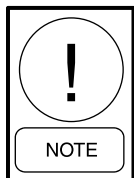

NOTE: The initial purchase and installation cost of an additional conductor is minimal compared to the cost of installation at a later date. The additional conductor is recommended due to the frequency of communication problems experienced with remotely mounted equipment.

When connecting the conductor to the ground, a small resistor (approximately 100 ohm, 2 watt) should be installed at one end to reduce the magnitude of current flow in the conductor.

Termination

On an ISN network (between MicroGateways) a Terminator Module (Part Number 031-01488-000) is required at each network end device. (An end of LAN device can be identified as one that has only one set of RS485 LAN wires connected to it.) This provides biasing of the network and assists in returning the signal to a normal state in the event of voltage transients.

Protection of Communication Ports

When using RS485 technology it is possible that electrical disturbances, such as voltage spikes or stray voltage, can damage a circuit board. The MicroGateway includes tranzorbs at the RS485 ports to protect against these spikes. Not all micro panels include tranzorbs. Refer to the chiller documentation for recommendations on installing tranzorb protection.

Cable Specifications

Power Cables



CAUTION: Aluminum wire is absolutely not acceptable.

For an enclosure style MicroGateway the power cable should be at least an 18 AWG copper wire rated for 10 amps per core at 250 volt AC. If the power cable uses three conductors, the ground conductor must be, as a minimum, the same size with the same current carrying capacity as the live and neutral conductors.

Network Cables

In most cases the network cables are specified and provided by a third-party integrator. For the MicroGateway to chiller interface, a twisted-pair cable, with an overall shield and drain wire, with conductors being at least 24 AWG is the minimum.

User Selections

Setting the Rotary Switch

Many micro panels use a small rotary switch to set the address of the chiller micro panel on a York Talk network, (York Talk ID address = Rotary Switch + 1). Since the MicroGateway uses a one to one relationship with the chiller panel, this switch is normally set to 0 (York Talk ID address 1) in all cases but that of a master/slave configuration. In this case the master micro panel rotary switch should be set to 0 (York Talk ID address = 1) and the slave micro panel to 1 (York Talk ID address =2).

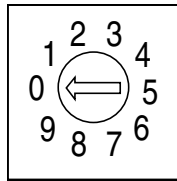

If the chiller micro panel is not equipped with a rotary switch, the York Talk address (chiller ID) is embedded in the software. In most cases this is user configurable. Some models of chiller use a fixed chiller panel ID which cannot be changed. Refer to the chiller documentation for information on software configuration of the York Talk address or chiller ID.

MicroGateway Jumpers

The MicroGateway is equipped with a jumper (J7) to provide a means of disconnecting the capacitor from the backup circuitry. The jumper should be installed at all times. If removed without power connected, all configurations and setup parameters will be lost.

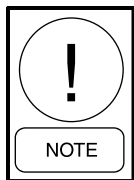

NOTE: The MicroGateway can be programmed to communicate to chillers with different network addresses unless a CLIP is in use. Refer to the Operation Manual.

Table 3 – Cable Requirements

		Network Cable (EIA485)	Analog, Pulse Inputs and Analog Outputs	Digital Input	Digital Outputs	Serial Devices (EIA232)	
Non-Plenum	Part Number	025-40390-012	025-40390-022	025-40602-052	025-40391-032	NA	NA
	Color	Gray/Yellow Stripe	Gray/Green Stripe	Gray/Purple Stripe	Gray/Orange Stripe		
	No. of Pairs	1	1	1	1		
	Shield	Yes	Yes	No	No		
Plenum	Part Number	025-40391-132	025-40390-122	025-40602-152	025-40390-112	025-40390-144	025-40603-146
	Color	Yellow	Green	Gray	Orange	Blue	Tan
	No. of Pairs	1	1	1	1	2	3
	Shield	Yes	Yes	No	No	Yes	Yes

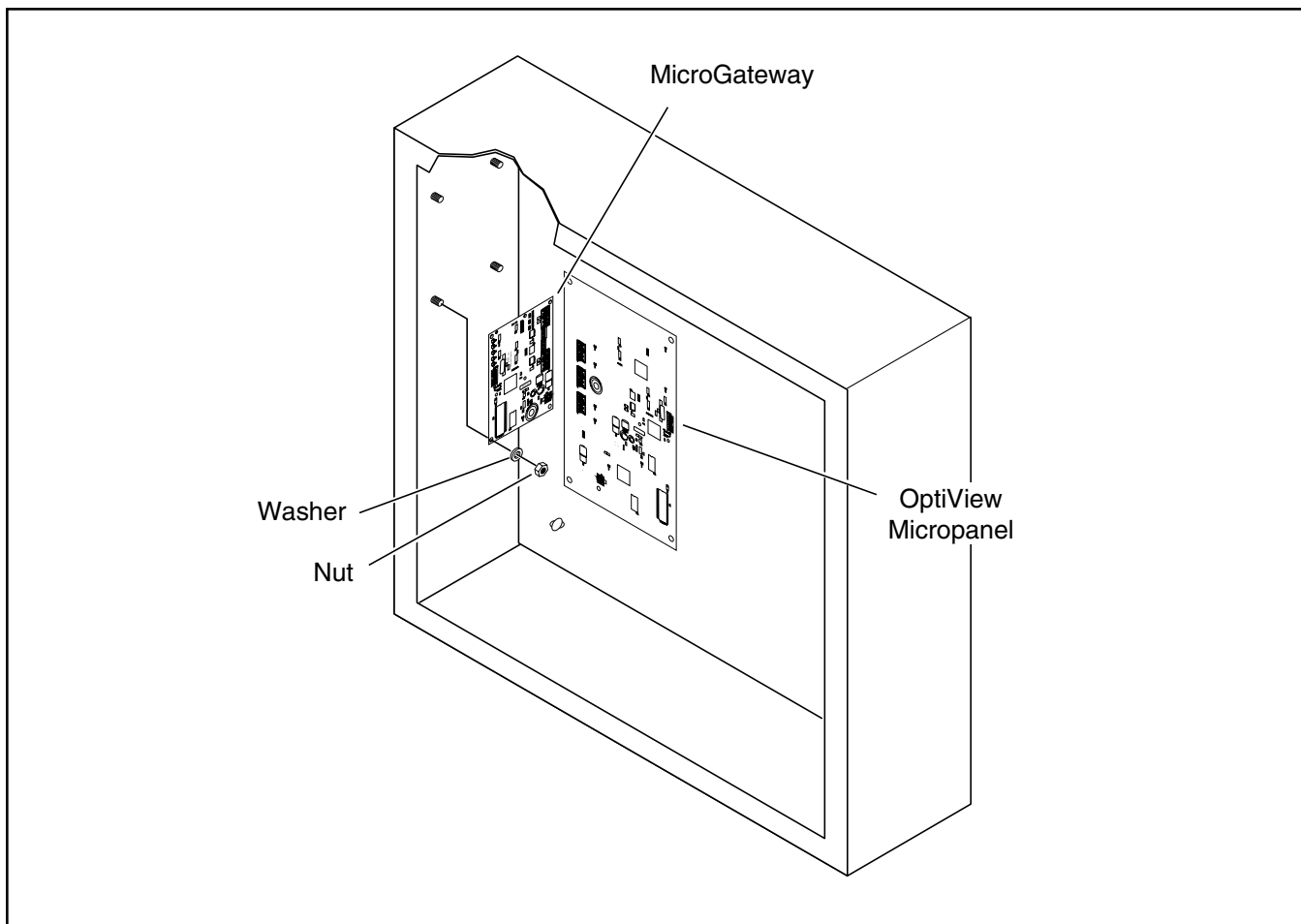

Figure 6. OptiView Mounting

3

OptiView Installation



CAUTION: Always disconnect power to the chiller panel when working inside. Dropped tools and metal chips from drilling can cause short circuits.

1. Disconnect power to the chiller micro panel and follow standard lock out procedures to prevent electrocution and inadvertent activation.
2. Attach the MicroGateway board to the studs in the upper left corner of the OptiView enclosure using the four screws and washers provided.
3. Connect the communications cable (included with the kit) from TB3 on the MicroGateway to J2 on the OptiView micro panel. Ensure that wires are connected according to Table 4.

Table 4 – OptiView Wiring (Port 1)

MicroGateway Port 1	OptiView Port	Wire Color
RX1	GTX	White
TX1	GRX	Blue
GND	NA	Shield or Drain

4. Connect the BACnet wiring to TB2. Refer to Table 5 for BACnet wiring information.

Table 5 – BACnet Wiring (Port 2)

	MicroGateway Port 2	BACnet Device	Wire Color
RS485 (TB2)	P2-2	–	White
	P3-2	+	Blue
	GND	OPEN	Shield or Drain

5. Check for frayed wire strands which could

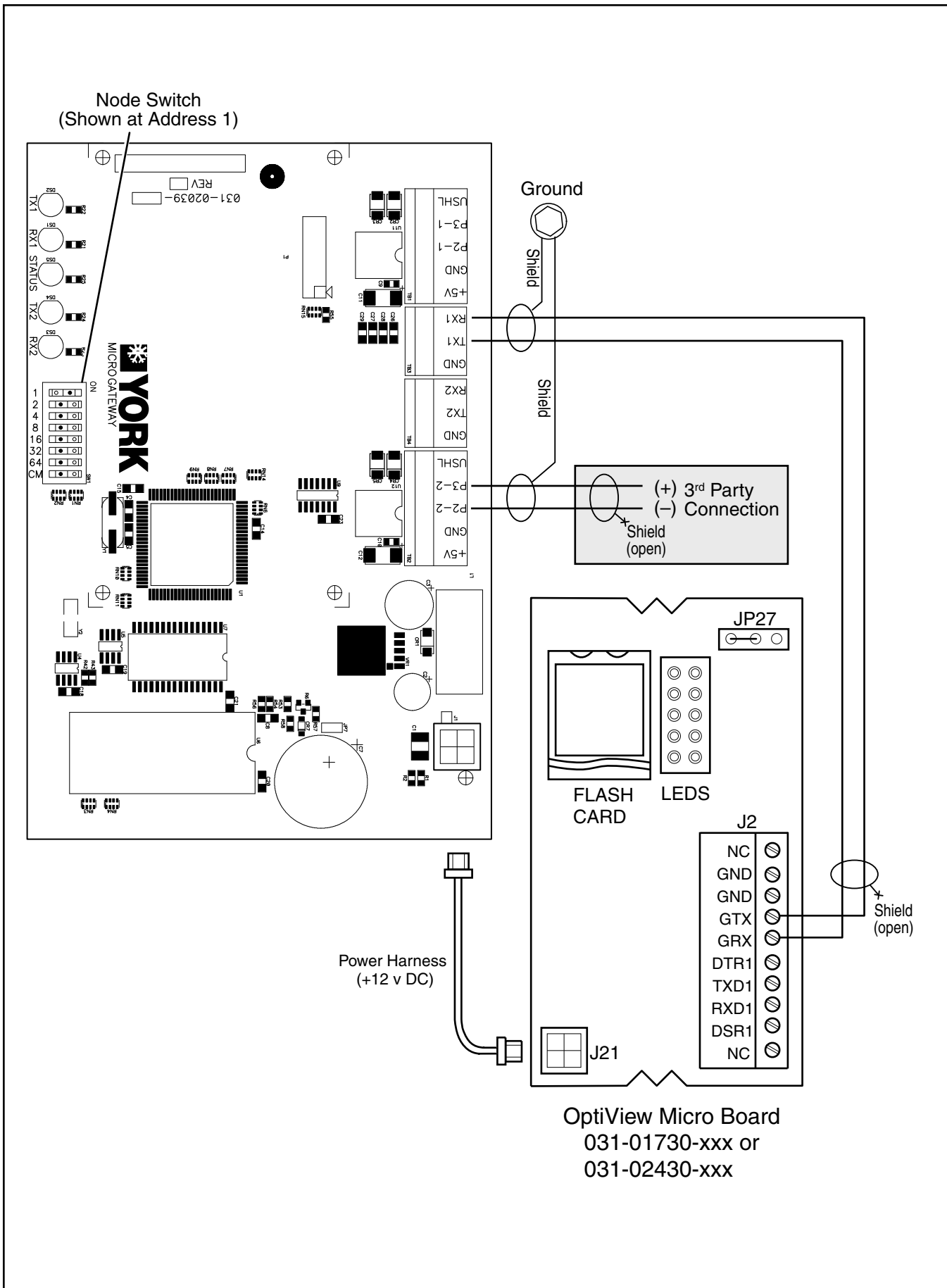

Figure 7. OptiView Connections

cause a short circuit. Ensure that all components are secure.

6. Ensure jumper J27 is set for RS232 (refer to Figure 7 – OptiView Connections).
7. Connect the power harness (included with the kit) from J1 on the MicroGateway to J21 on the OptiView micro panel (refer to Figure 7).

The MicroGateway board is now ready to be configured using Quick Start. Refer to Section 4 Commissioning in this manual.

Other Chiller Panels



CAUTION: *Never install the MicroGateway outside the confines of a building unless mounted within another enclosure rated at IP 65/ NEMA 4X or higher.*

For non-OptiView applications the MicroGateway includes an enclosure. It does not include communication cables due to the variety of types and lengths which may be required.



WARNING: *Under no circumstance should the MicroGateway be installed inside a high voltage enclosure (>75 volts). This configuration will result in unreliable operation.*

The MicroGateway can be mounted as a stand-alone enclosure on either the outside surface of the chiller micro panel (close coupled) or on a smooth surface within close proximity of the chiller panel enclosure.

For mounting on a micro panel, the line voltage power is typically drawn from inside the micro panel.

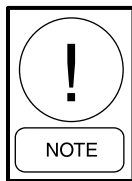

NOTE: *Always ensure that the cover is securely fastened to the enclosure when operating and the internal ground wire is attached. This helps to prevent RFI from entering the system.*

Mounting on a Micro Panel



CAUTION: *Always disconnect power to the chiller micro panel when working inside. Dropped tools and metal chips from drilling can cause short circuits.*

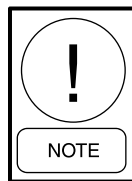

NOTE: *When attaching the MicroGateway to a micro panel, make sure the MicroGateway does not impede access to other components around the micro panel.*

1. Disconnect power to the chiller micro panel and follow standard lock out procedures to prevent electrocution and inadvertent activation.
2. Make sure the MicroGateway enclosure will fit properly and that no obstructions, such as internal boards, switches or external conduit, prevent mounting or servicing of the panel.
3. Locate and remove the two plastic caps in the bottom of the MicroGateway enclosure.
4. Mark an appropriate place on the enclosure for a matching set of knock out holes. Mark and drill or punch two holes in the micro panel.



CAUTION: *Be careful not to damage the circuit cards in the MicroGateway or micro panel during installation. Protect all circuit boards from metal chips which may cause short circuits if left on the boards at start-up.*

5. Using two bulkhead pipe couplers (PN 025-14158 or equivalent), attach the MicroGateway enclosure to the micro panel.

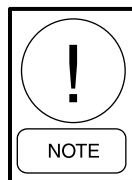

NOTE: *Use of the bulkhead pipe couplers will provide sufficient clearance to allow removal of the MicroGateway cover.*

6. Complete the wiring as outlined in “Connecting Power” in this section.

3

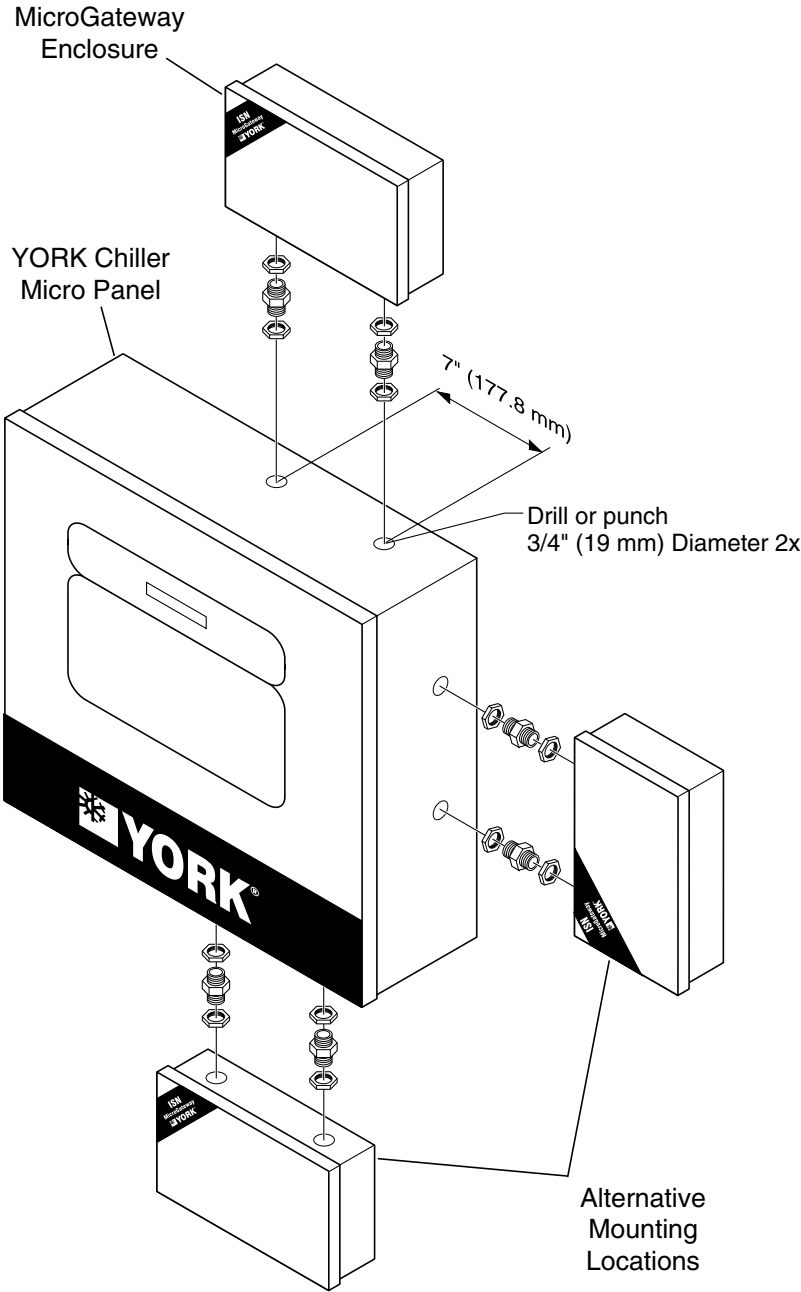
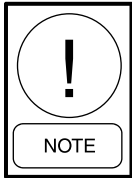

Figure 8. Non-OptiView Enclosure Mounting

Wall Mounting



NOTE: When wall mounting the *MicroGateway* make sure there is no interference with other components in the near vicinity. Use appropriate conduit to connect the power and communications wiring to the *MicroGateway*.

1. Check for proper clearances for the necessary electrical and communications cable runs.
2. Power and communications wiring must comply with all local ordinances and customer requirements.
3. Select a suitable location and mark the anchor points. Ensure that the enclosure will be level.
4. Drill the appropriate holes in accordance with the type of wall anchor being used.
5. Install the enclosure on the wall. Be careful not to damage the circuit cards during installation.
6. Check that the mounting is secure and the wiring connections are correct and tight. Check that there are no loose wire strands or other metal objects that could cause a short circuit on the circuit board.
7. Complete the wiring as described in “Connecting Power” in this section.

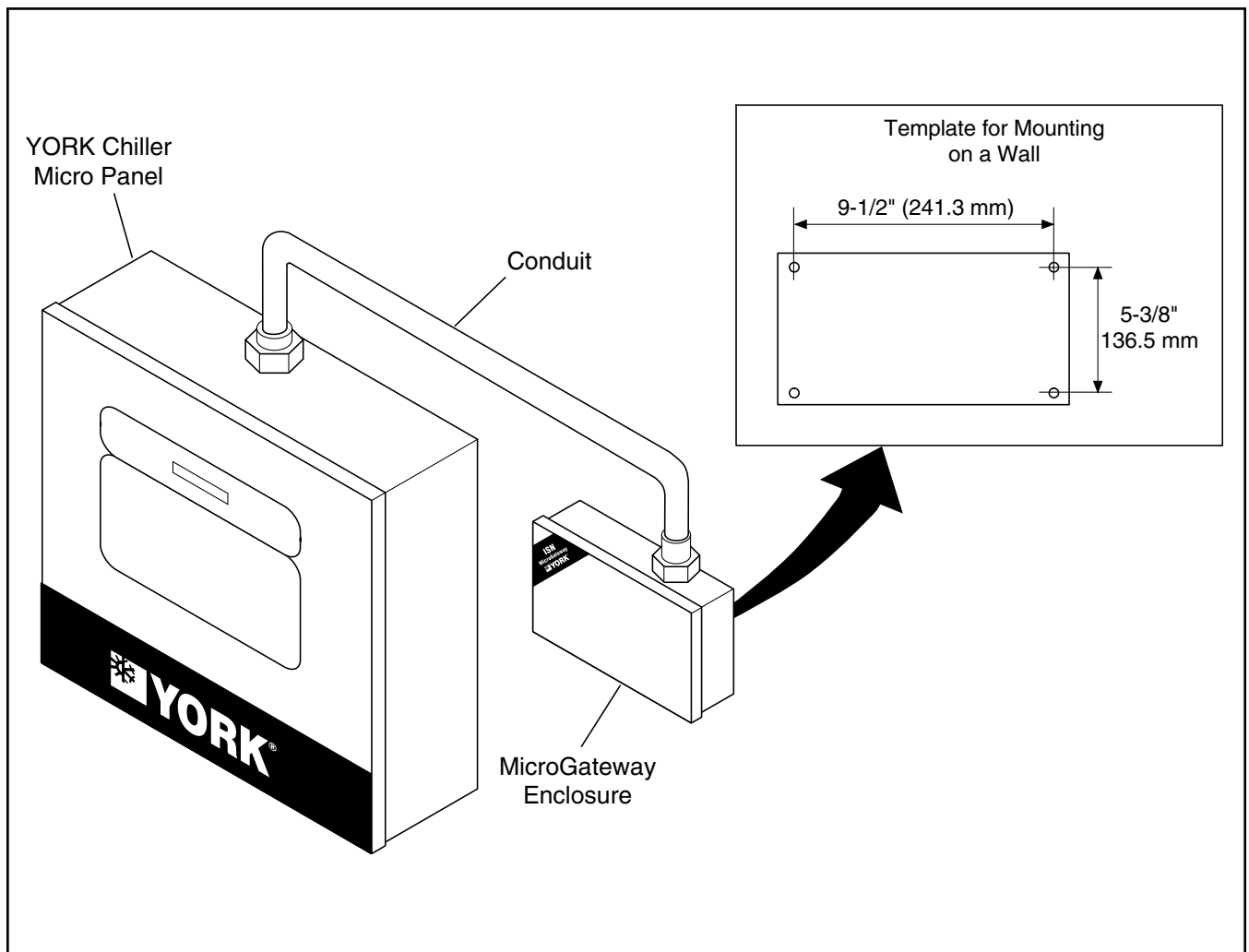

Figure 9. Wall Mounting

Connecting Power

When using an enclosure type of MicroGateway, power can be drawn from either a separate power supply or from the main terminal strip in the chiller panel. The power source should be located within 3 feet (2.9 m) of the MicroGateway and protected with a suitable fuse or circuit breaker. Ensure the power is from an uninterrupted source, i.e. not controlled by a programmed switch.

If the enclosure is mounted on a wall, the wiring from the power source to the MicroGateway must always be run in a suitable conduit. To obtain the best EMI and EMC performance, care should be taken to ensure that the conduit is bonded to the metal of both enclosures. Scraping the paint around the knockouts usually helps provide a better electrical connection between the joining parts.

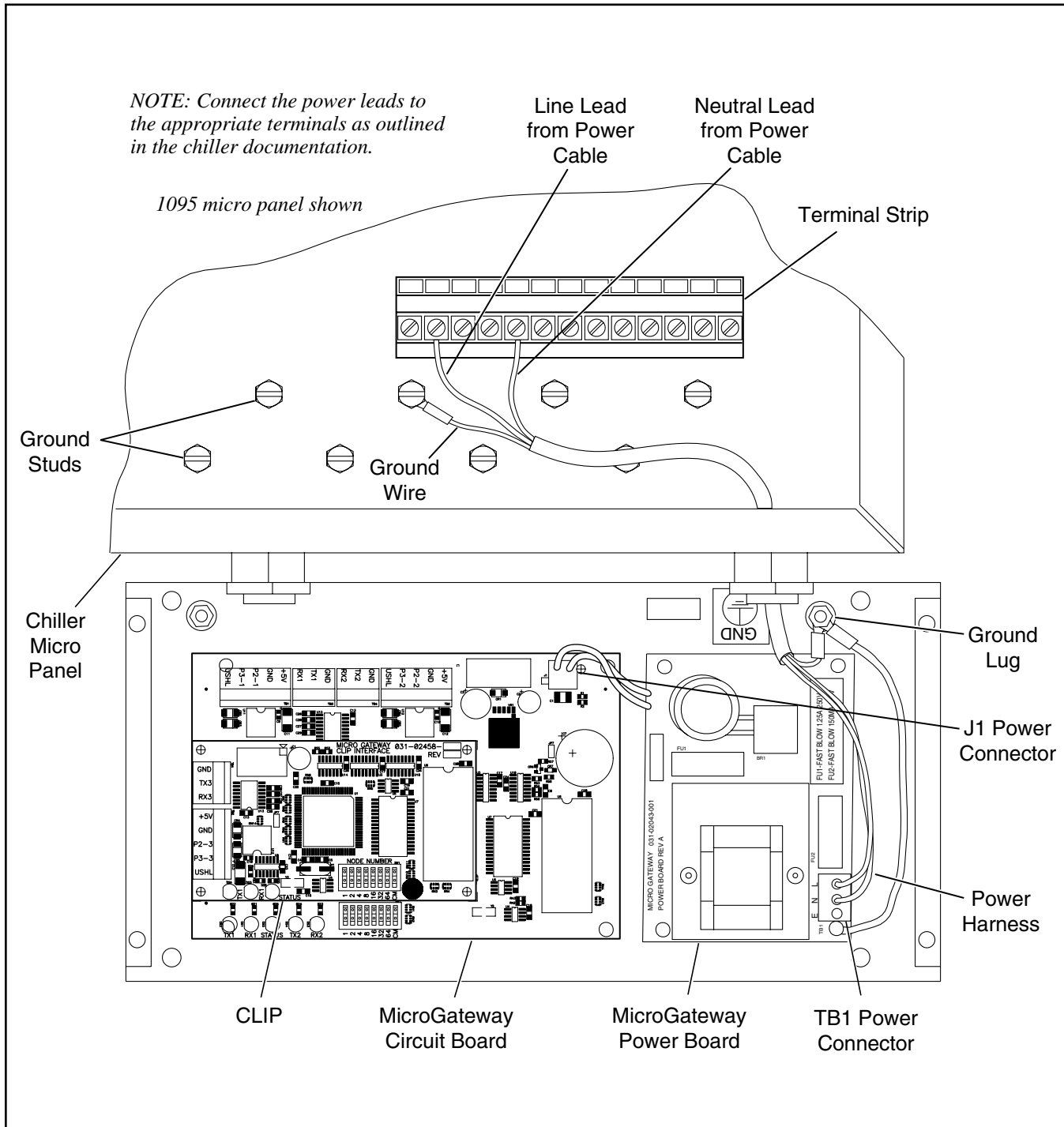

Figure 10. Typical Power Connections for Close-Coupled MicroGateway



CAUTION: Make sure the power source, whether an external power source or from a chiller panel, is rated sufficiently to support the MicroGateway's load.

1. Disconnect power to the chiller micro panel and follow standard lock out procedures to prevent electrocution and inadvertent activation.
2. Connect a 16 - 18 AWG wire from a reliable ground reference to the grounding lug in the MicroGateway's enclosure using a suitable crimp. Do not remove the existing wire that connects the grounding lug to the power board (031-02043-xxx).
3. Remove the input connector at TB1 from the power board. Using a screwdriver or a similar tool, depress the small tabs on the side of the connector and insert the proper wires as labelled on the board (N, L).



CAUTION: The ground wire must be connected to the ground stud to ensure the enclosure is grounded if the power plug is disconnected.

4. Check for loose wire strands. Reinsert the connector into the power board.

Connecting the Communications Wiring

The chiller panel is always connected to Port 1. The BACnet LAN is always connected to Port 2.

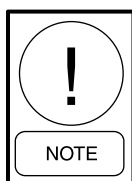

NOTE: Due to the variety of cables and lengths required, communication cables are not included with any enclosure-style MicroGateways. Be sure the cables used meet standard RS232 or RS485 specifications shown in the table titled "Recommended Cable Specifications."

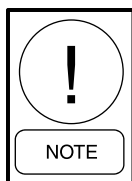

NOTE: Figures 11 through 21 show the wiring and jumper settings for specific micro panels. Only the applicable details, i.e. jumpers, connectors, rotary switch, are shown for each board. Refer to the chiller documentation for additional switch or software settings.

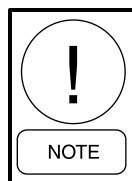

NOTE: When installing a MicroGateway on an older micro panel, please check that the software resident in the micro panel is capable of supporting York Talk communications. Some older units (prior to 1990) were not York Talk-ready and may require a software update.

1. Connect the cable to either TB1 or TB3 on the MicroGateway to the appropriate terminals on the chiller micro panel.
2. Connect the BACnet LAN cable to TB2 on the MicroGateway.
3. Check for frayed wire strands which could cause a short circuit. Ensure that all components are secure.
4. Verify that the chiller ID switch (rotary switch) on the micro panel is set to 0 if the chiller is the master or to 1 if the chiller panel is a slave.

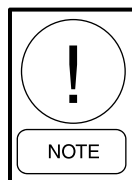

NOTE: When the chiller rotary switch is set to 0, the York Talk ID address is 1. When the chiller ID is set to 1, the York Talk ID address is 2.

5. Check the jumpers on the micro panel for proper settings.

CLIP Communication

The CLIP uses Modbus communications which can operate on an RS232 or RS485 layer via Port 3. Port 3 has connectors labeled TB4 (RS232) and TB2 (RS485) to accommodate either type of signal. For details on connecting the Modbus RTU monitoring network to the CLIP, refer to the CLIP manual.

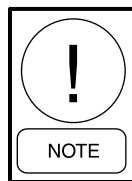

NOTE: The CLIP is not shown on Figures 11 through 21 for clarity.

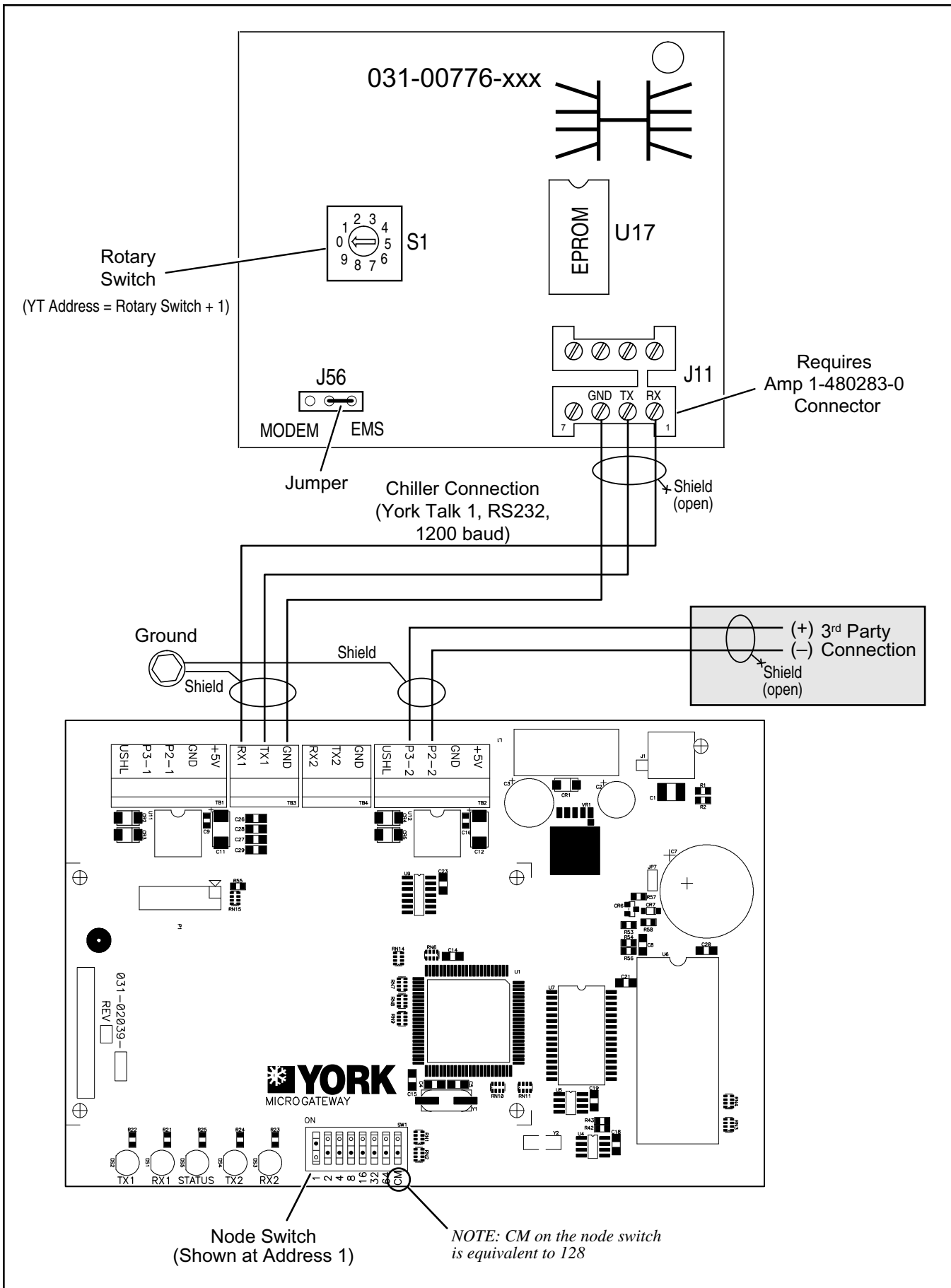
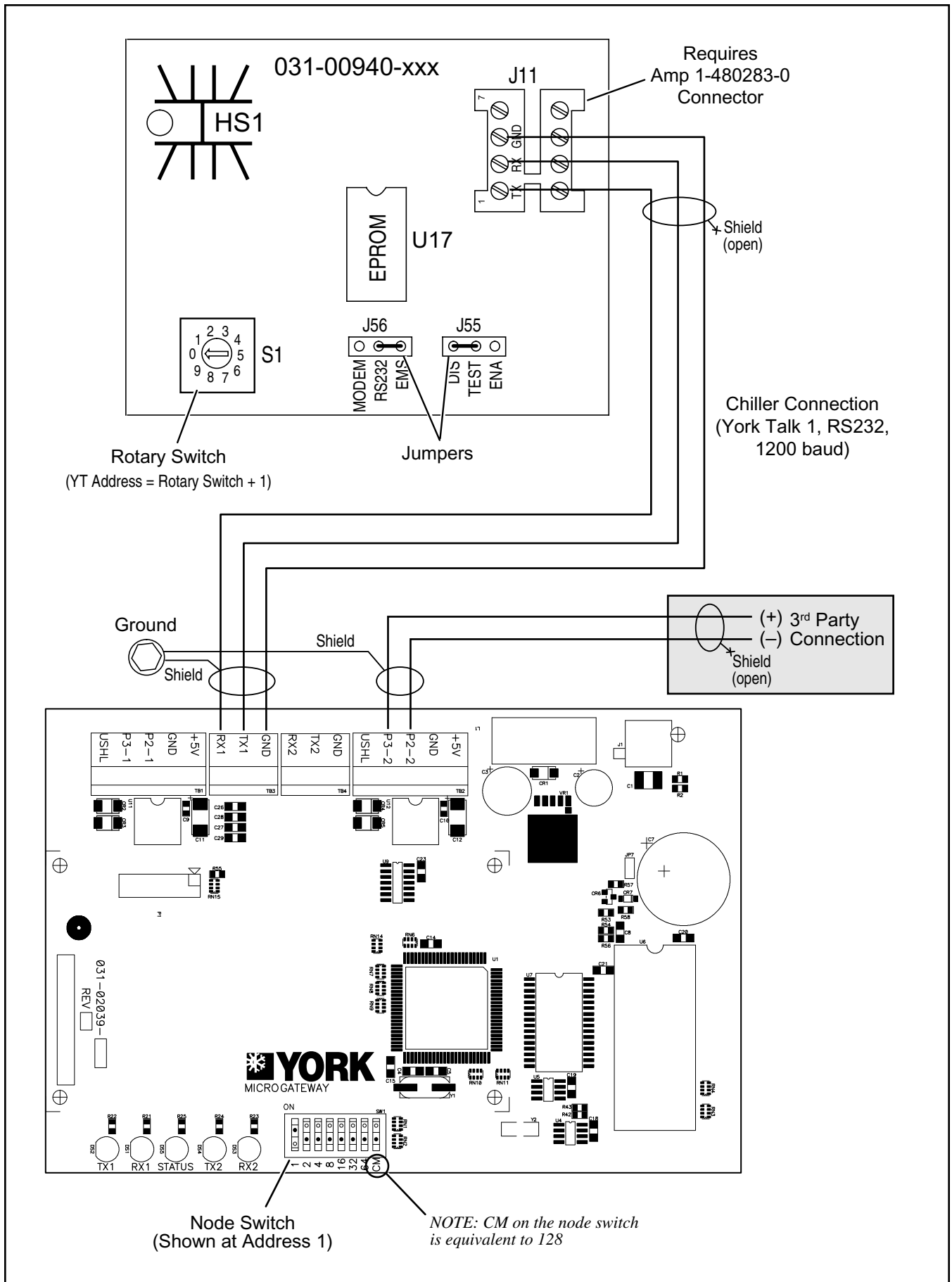

Figure 11. 776 Board Connections



3

Figure 12. 940 Board Connections

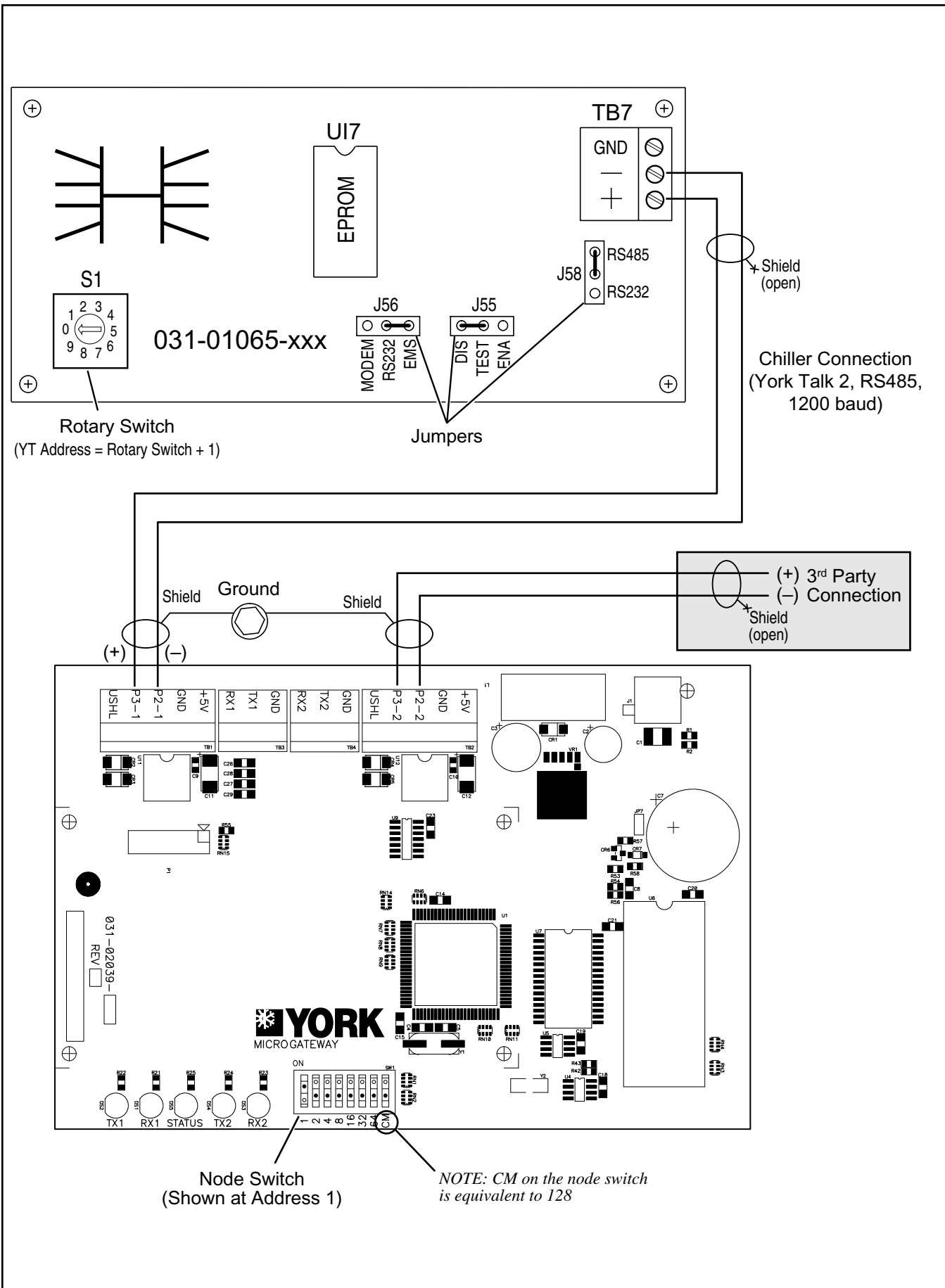
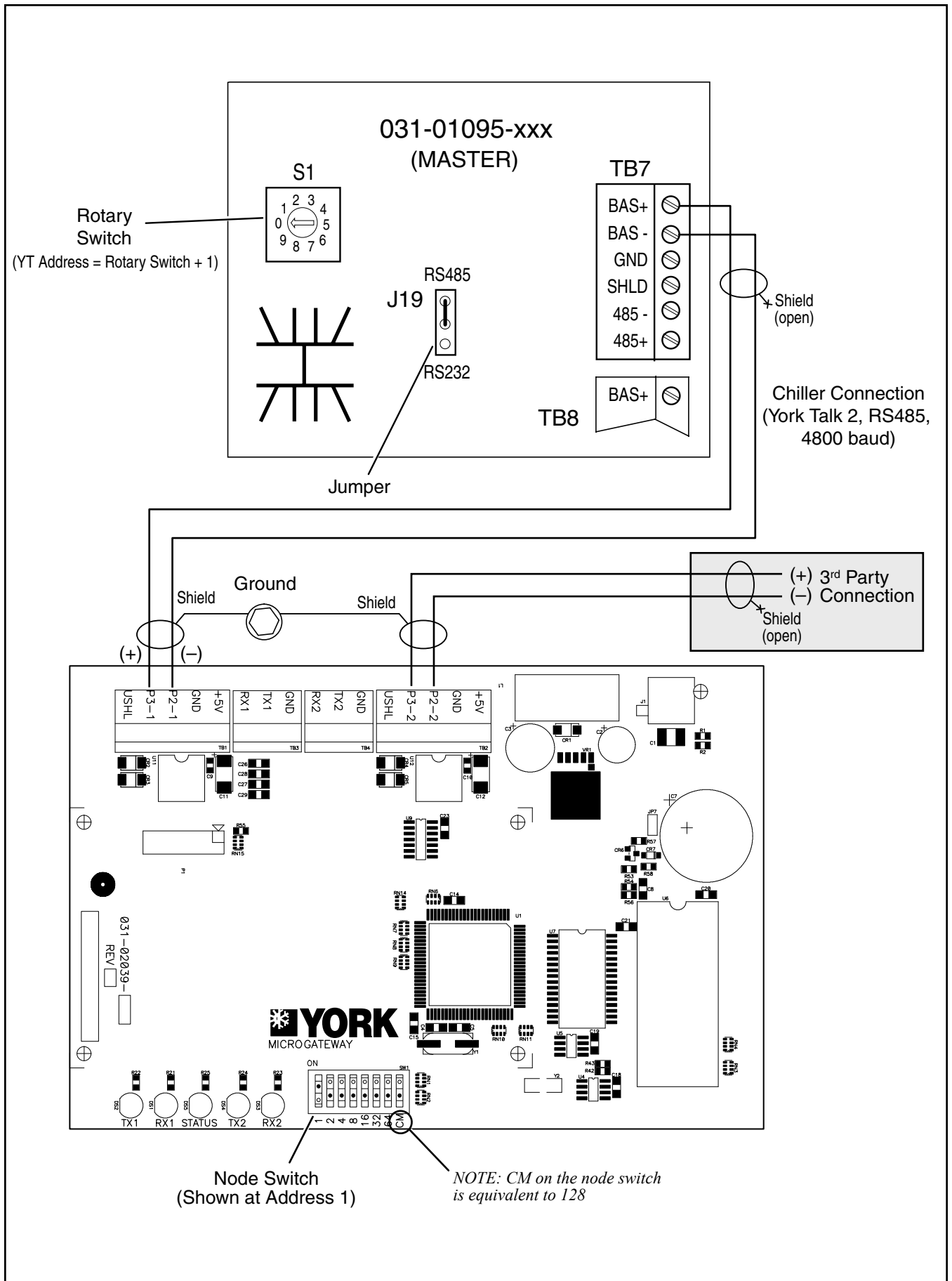

Figure 13. 1065 Board Connections



3

Figure 14. 1095 Master Board Connections

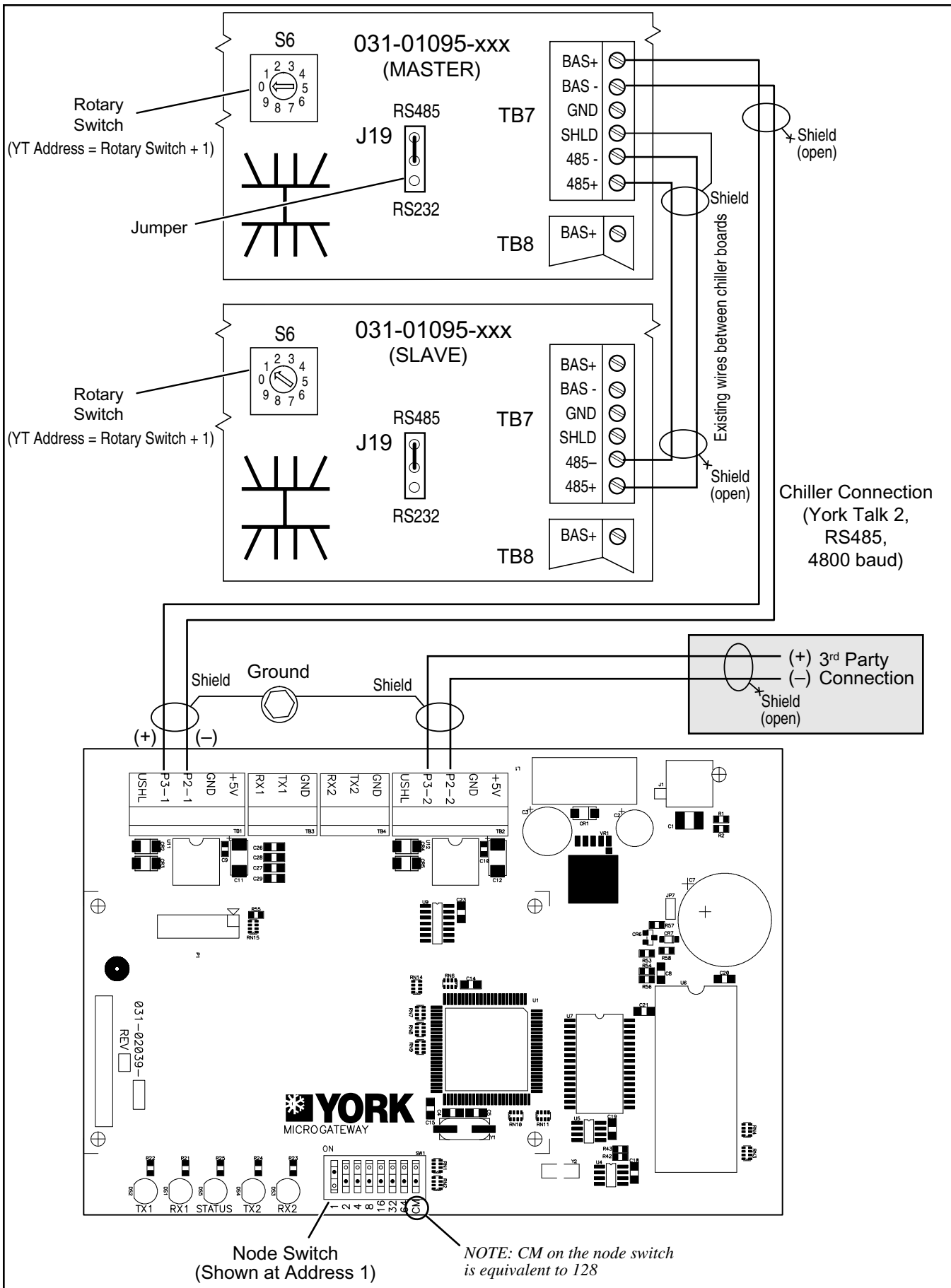
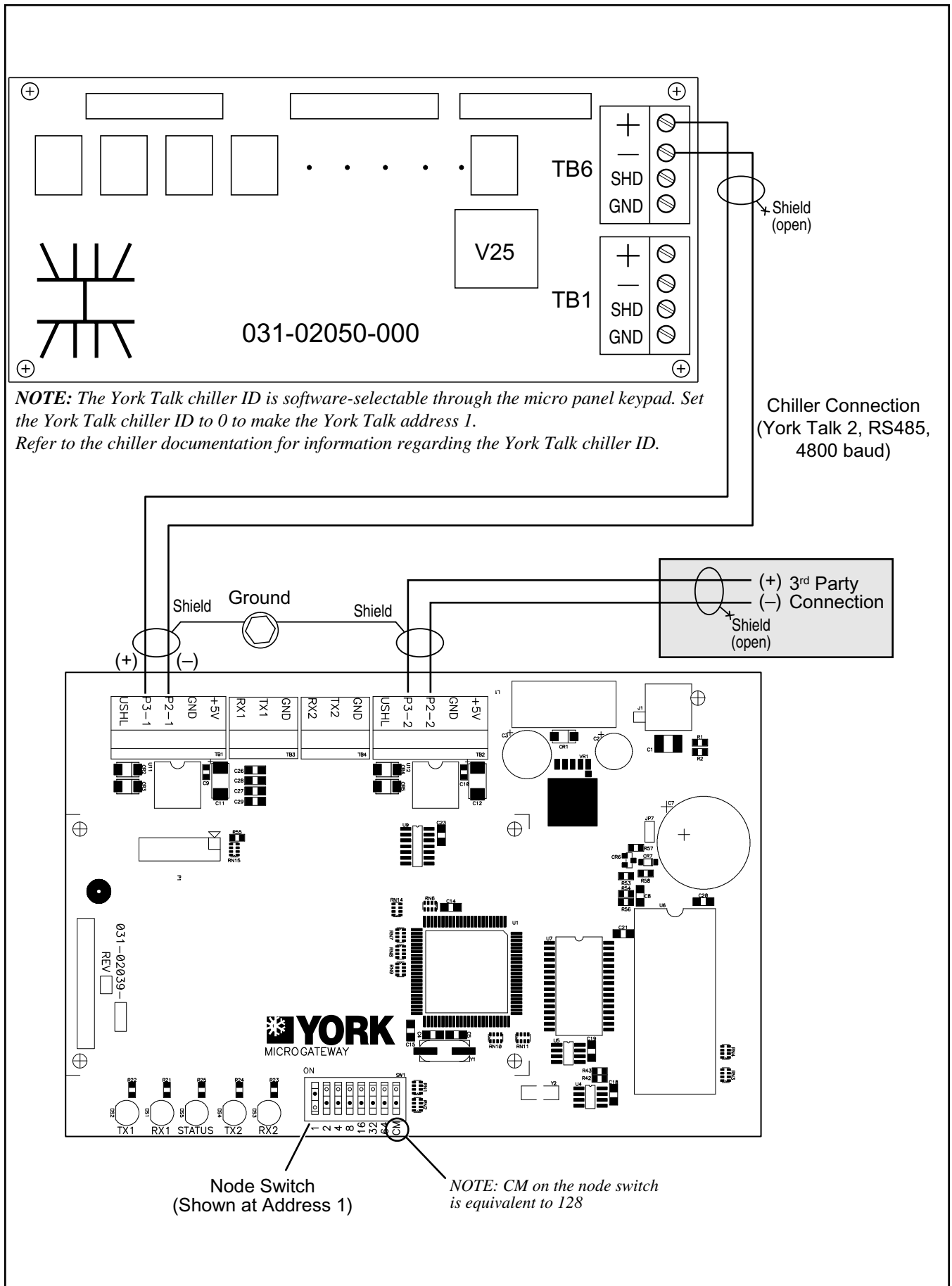

Figure 15. 1095 Master/Slave Board Connections



3

Figure 18. 2050 Board Connections

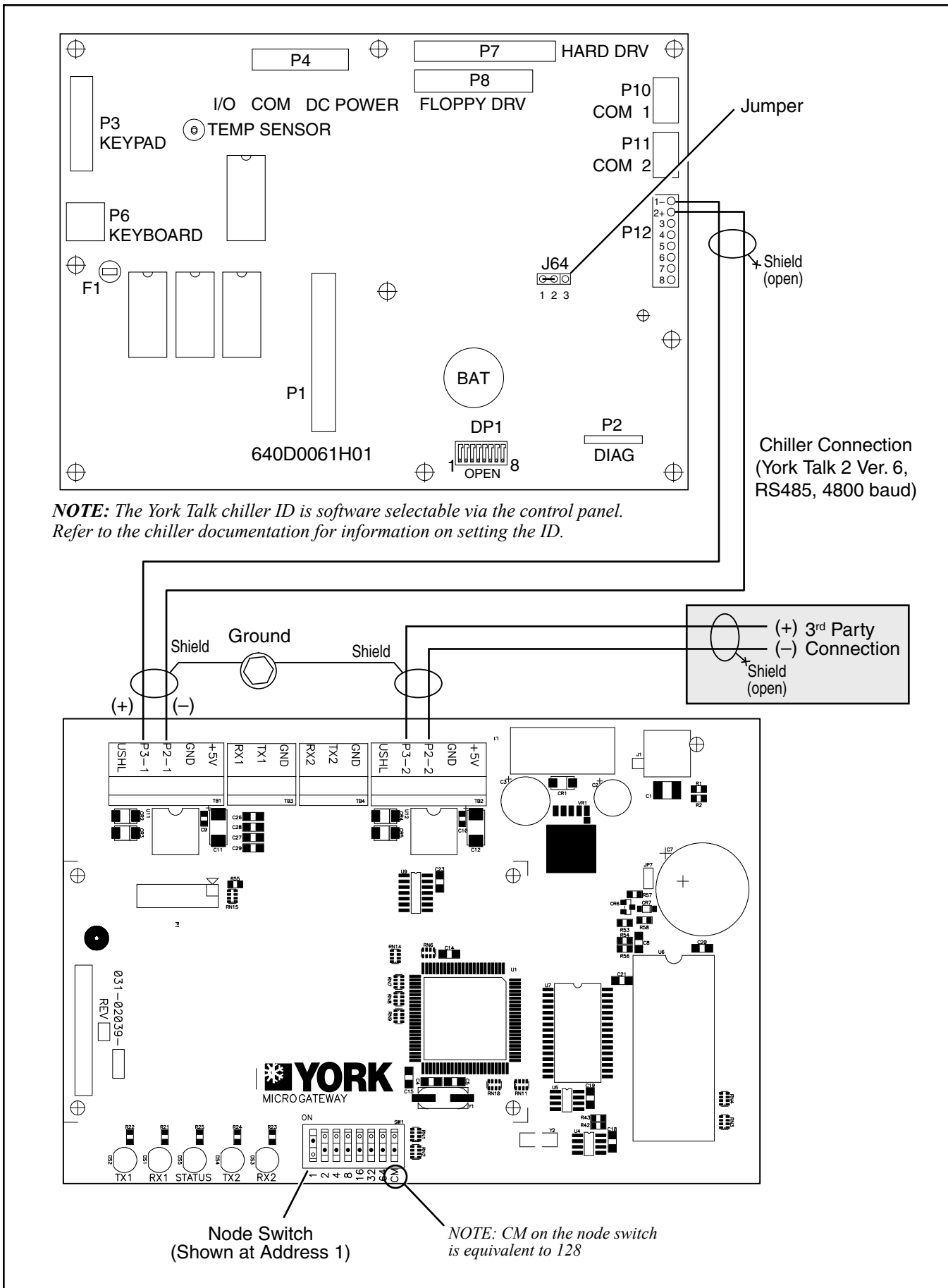
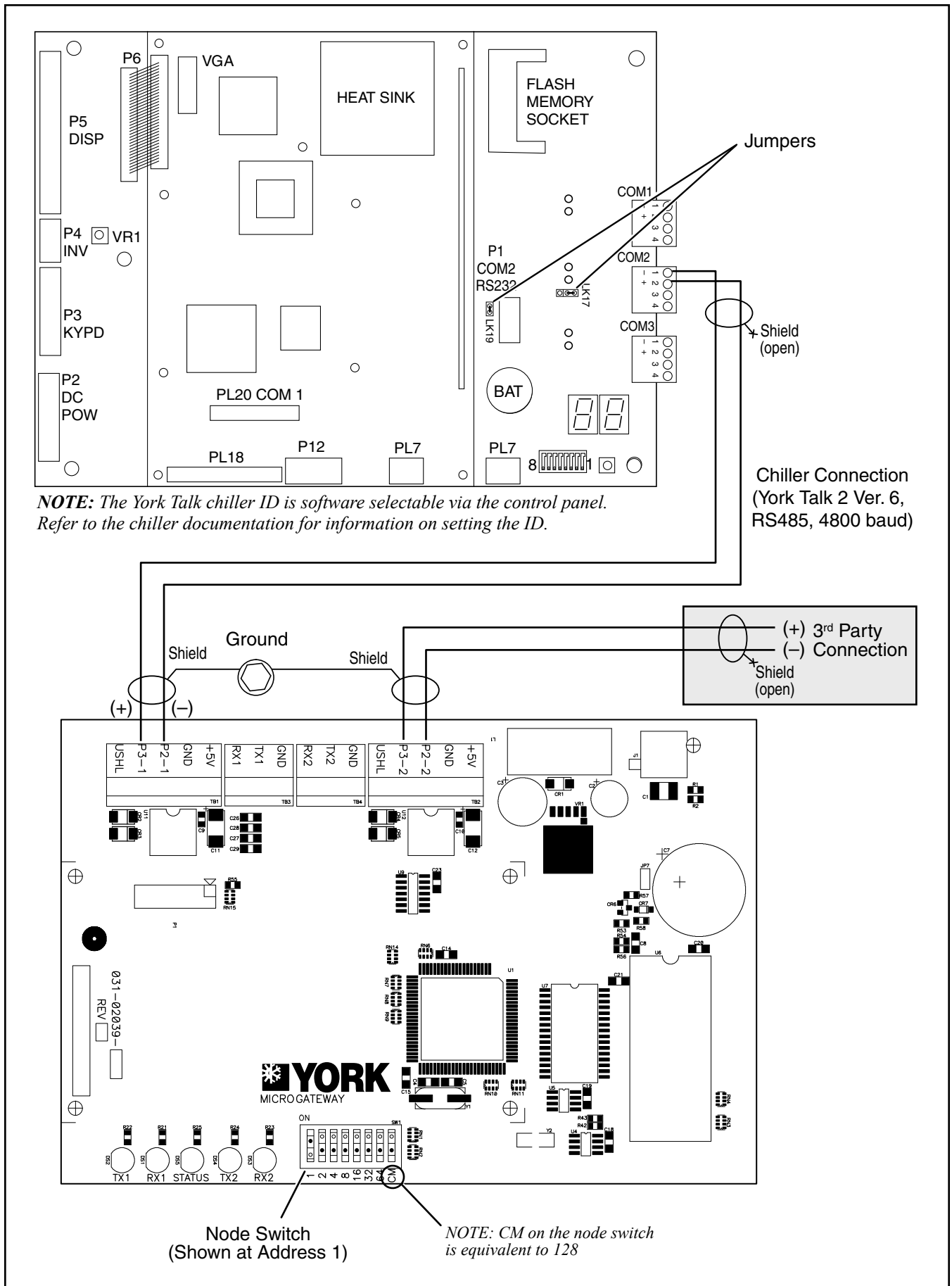

Figure 19. Frick Quantum 1 and 2 Board Connections



3

Figure 20. Frick Quantum 3 Board Connections

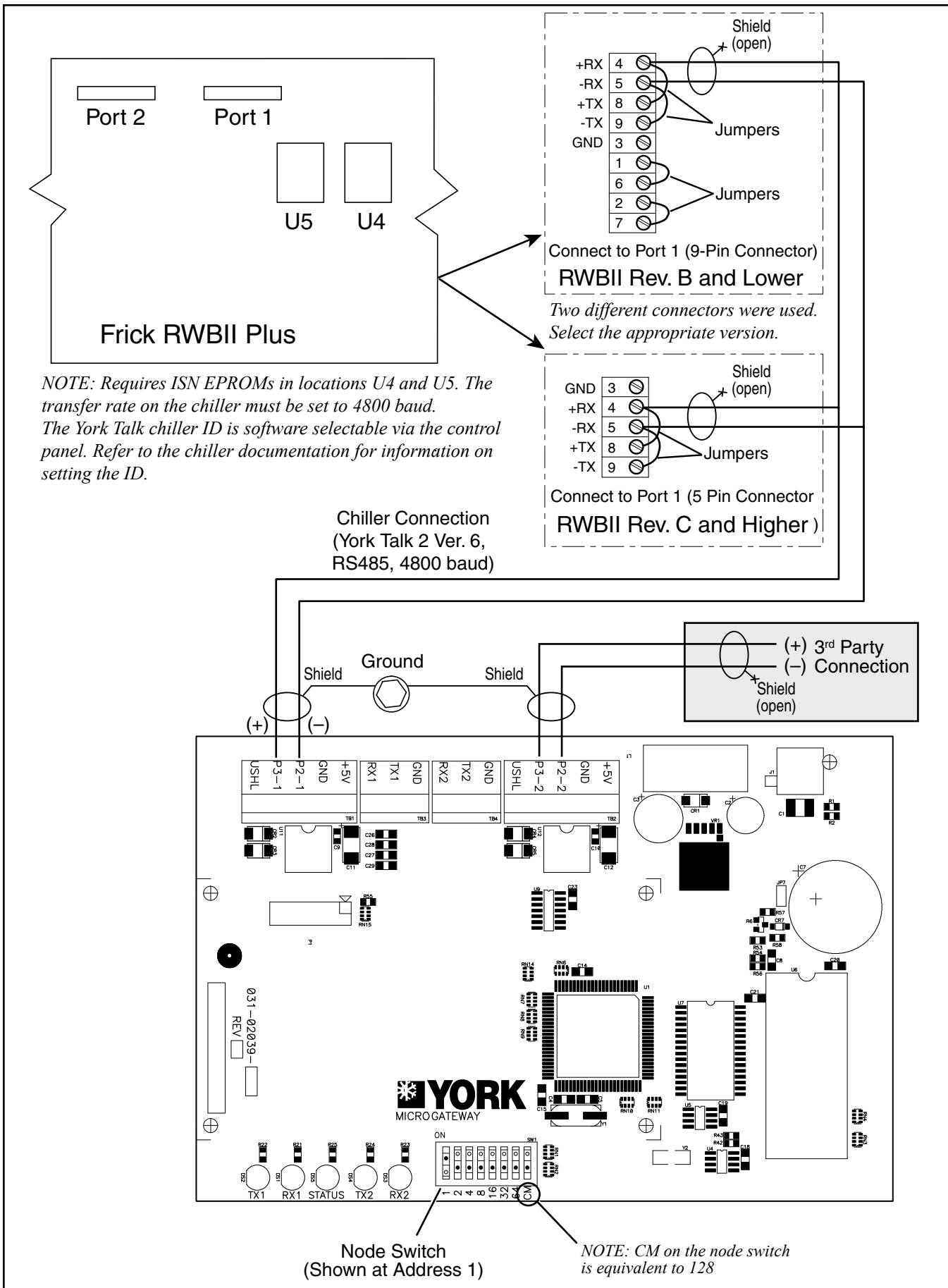

Figure 21. Frick RWB II Board Connections

SECTION 4 COMMISSIONING

Once the hardware is installed and wired the BACnet MS/TP MicroGateway must be configured for a specific mode of operation. Using the Quick Start feature, all currently offered chillers using the factory-defined points list can be configured for standard communication. The MicroGateway can also be customized using a VT100 terminal or computer using terminal emulation software. Refer to the *Operation Manual* for customizing the MicroGateway's operation.

Table 6 – Default Settings

	PROTOCOL	COMMUNICATION
PORT 1	YK with SSS using York Talk 3	19.2 kbaud and odd parity
PORT 2	BACnet MS/TP	9.6 kbaud and no parity
PORT 3	Modbus RTU	19.2 kbaud and no parity



CAUTION: If the York Talk Points List is modified in any way, the MicroGateway and CLIP will lose reference to one another and be unable to transfer data.

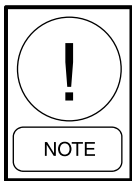

NOTE: Do not apply power to the unit before reading this section.

How to Use the Node Switch

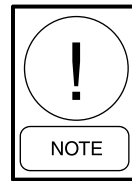

NOTE: The MicroGateway circuit board and CLIP each have a node switch. The Quick Start process must be followed specifically to ensure compatibility between the two processors.

The node switch has two purposes. It enables a user to set a unique BACnet network address as well as enabling a specific Quick Start option.

The node switch consists of eight individual DIP switches that are binary weighted. Summing the value of each of these switches in the ON position forms the decimal value of the node switch. To determine the numeric value assigned to the switch, add the numbers above the corresponding DIP switches which in the ON position. The resulting sum is

Default Settings

When shipped from the factory, the BACnet MS/TP MicroGateway is set up as shown in Table 6. For more specific information on the default settings, refer to the *Operation Manual*.

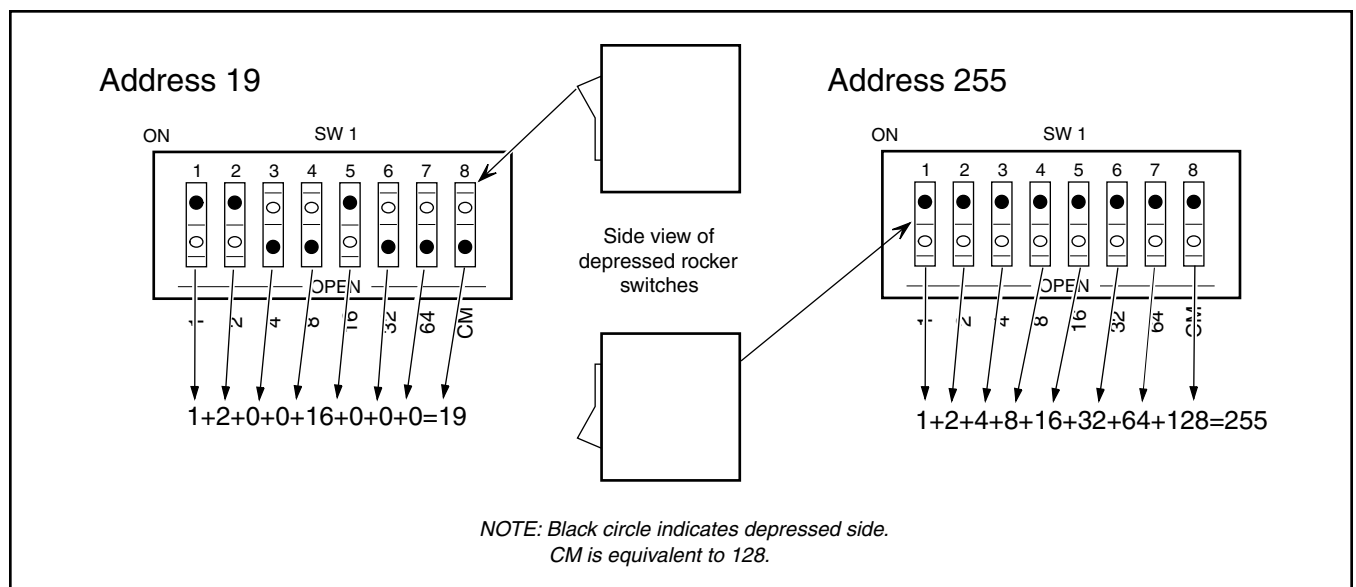
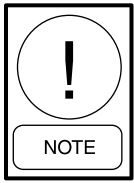

Figure 22. Setting the Node Switch

the number (address) selected, which is either the network address or a Quick Start option.



NOTE: *The CM DIP switch is equivalent to binary value 128.*

Setting the Network Address

The BACnet network node number should be selected so it is unique on the network. Because of the Quick Start feature, the MicroGateway’s possible network address is from 1 to 200 excluding 128, which is used for a Quick Start function. Addresses from 201 to 255 are used to select the various Quick Start features.

The MicroGateway and the CLIP will have different network addresses and reside on different networks.

Quick Start

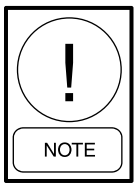

NOTE: *The Quick Start functions in the same manner on the CLIP and the MicroGateway circuit boards.*

Quick Start allows a user to select a configuration for the most popular chillers, select terminal mode for computer communications, select metric or imperial units and run a basic “loop back” communications test using the node switch. The node switch is used to select the Quick Start features and the STATUS LED flashes to indicate and verify that the proper Quick Start feature is selected.

The Quick Start features are shown in Tables 7 and 8. Table 7 defines the chiller types and communication rates. Table 8 lists auxiliary features.

When a Quick Start selection is made, the STATUS LED flashes a predefined code to allow the user to verify that the required selection has been made. The STATUS LED continues to flash as long as the Quick Start selection is in force.

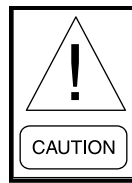

CAUTION: *It is highly recommended that Quick Start 128 be invoked whenever changing chiller profiles using the Quick Start feature. This clears any items not overwritten by a new Quick Start. It is not necessary to use Quick Start 128 when setting auxiliary features.*

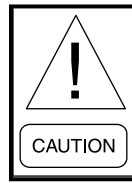

CAUTION: *The DIP switch on the CLIP and MicroGateway must be selected in the exact order specified, i.e., first the MicroGateway switch, then the CLIP switch. Otherwise, synchronization between the two boards cannot be assured.*

Changing the node switch to the network address will not remove the Quick Start information from the E² memory. Therefore, it is highly recommended that the Quick Start 128 be invoked whenever changing chiller profiles using the Quick Start feature. This will clear any items not overwritten by a new Quick Start.

York Talk Points List

Along with the communication parameters, activating a Quick Start feature loads the standard set of micro-objects for an OptiView micro panel. An up-to-date list of the standard micro-objects, referred to as the York Talk Points List, for all YORK chillers is available at

<http://intranet.york.com/web0147>

This site also cross references the type of York Talk and micro panel board number used for specific chiller models.

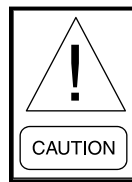

CAUTION: *If the York Talk Points List is modified in any way, the MicroGateway and CLIP will lose reference to one another and be unable to transfer data.*

For OptiView micro panels, the points may be modified for non-standard configurations. Refer to the Operations Manual for additional information.

Selecting a Quick Start Address

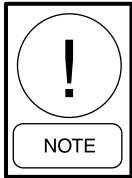

NOTE: It is recommended that power be removed from the MicroGateway/CLIP any time a node switch address is being modified.

To select a Quick Start feature, follow the procedure shown in the figure titled “Commissioning Sequence.” This guides the user through the process of selecting chiller profiles and auxiliary features.

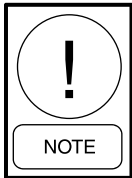

NOTE: Be sure to read the node switch correctly if it is installed upside down or sideways.

The selected Quick Start feature is loaded into memory when the MicroGateway first has power applied. The items remain in memory when power is removed unless they are overwritten by a new Quick Start. Hence the Quick Start information remains when the node switch is eventually set to the BACnet network address.

When communications between the MicroGateway and chiller micro panel are operating correctly, the STATUS LED flashes steadily at twice per second. If the communications are not operating properly, the STATUS LED flashes twice and is off for 3.5 seconds.

Once the port 1 communications are setup, the transmit and receive LEDs (TX1 and RX1) on port 1 should flash to indicate communication between the micro panel and MicroGateway.

After the port 2 communications are connected, the port 2 LEDs (TX2 and RX2) should flash to indicate network communication.

Quick Start 128

Selecting Quick Start 128 allows the user to re-configure the MicroGateway to ensure that no items have been inadvertently placed in memory and the unit is set to the original factory defaults.

The STATUS LED flashes 3 times per cycle until all the original data is recovered. When complete, the STATUS LED flashes normally at once per second.

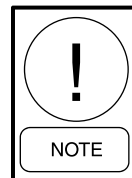

NOTE: When Quick Start 128 is invoked, only data that has been changed is transferred. If few changes have been made, the transfer may take less than a second and the 3 flashes per cycle will not be observed.

Sign-Off

A final check-out sheet is provided for use as a summary of the contents of this manual. This, along with other items required by the customer/contractor, should be provided when the job is complete. This ensures that the third-party Controls Contractor has been provided with the information required to communicate with the chiller through the MicroGateway.

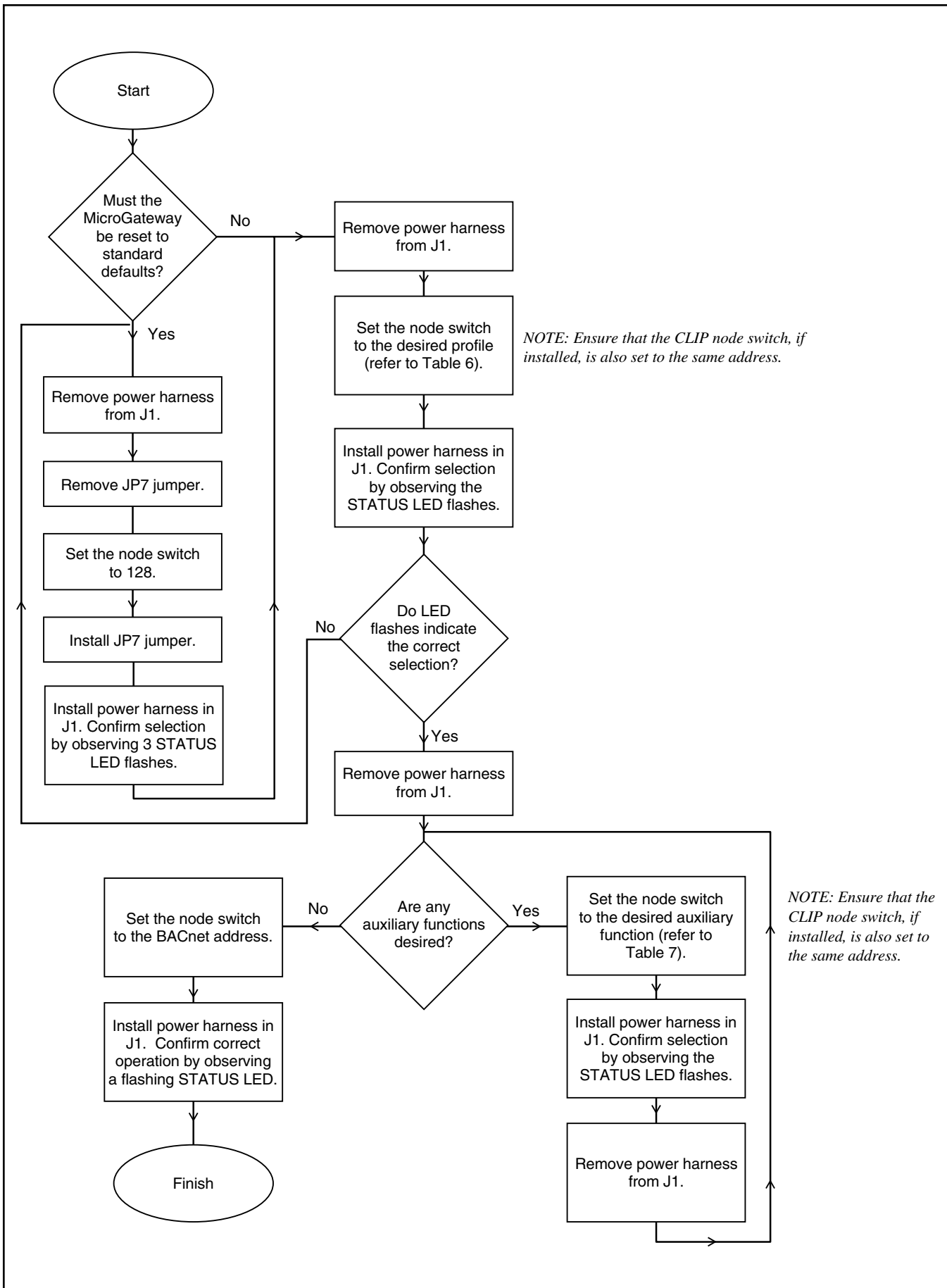
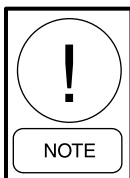

Figure 23. Commissioning Sequence

Table 7 – Quick Start Chiller Profiles



Chiller Type	No. of STATUS LED Flashes	Quick Start (NODE Address)	Switch Settings
Changes Port 2 to Terminal Mode (for use with a portable computer). Port 1 remains set to the default or previous Quick Start selection.	4	255	
Optiview YK with SSS or mechanical starter using York Talk 3 at 19.2 kbaud. Port 2 is set for BACnet MS/TP at 9600 baud, No parity.	5	254	
Optiview YK with VSD using York Talk 3 at 19.2 kbaud. Port 2 is set for BACnet MS/TP at 9600 baud, No parity.	6	253	
Optiview YT with SSS or mechanical starter using York Talk 3 at 19.2 kbaud. Port 2 is set for BACnet MS/TP at 9600 baud, No parity.	7	252	
Optiview YT with VSD using York Talk 3 at 19.2 kbaud. Port 2 is set for BACnet MS/TP at 9600 baud, No parity.	8	251	
Optiview YS/YR with SSS or mechanical starter using York Talk 3 at 19.2 kbaud. Port 2 is set for BACnet MS/TP at 9600 baud, No parity.	9	250	
Any York Talk 2 with one (1) section at 1200 baud. Port 2 is set for BACnet MS/TP at 9600 baud, No parity.	10	249	
Any York Talk 1 with one (1) section at 1200 baud. Port 2 is set for BACnet MS/TP at 9600 baud, No parity.	11	248	
Any York Talk 2 with one (1) section at 4800 baud. Port 2 is set for BACnet MS/TP at 9600 baud, No parity.	12	247	
Any York Talk 2 with two (2) sections at 4800 baud. Port 2 is set for BACnet MS/TP at 9600 baud, No parity.	13	246	

4

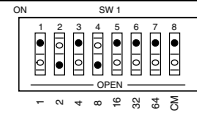
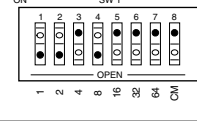
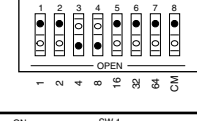
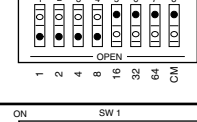
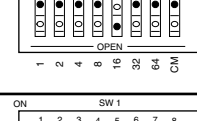
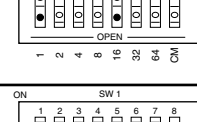

NOTE: Each Quick Start sets the equivalent Modbus RTU parameters on the CLIP.

Table 8 – Quick Start Auxiliary Functions

Chiller Type	No. of STATUS LED Flashes	Quick Start (NODE Address)	Switch Settings
Select Metric Units in the OptiView micro panel.	14	245	
Select Imperial Units in the OptiView micro panel.	15	244	
Runs a Communications Test on the MicroGateway (Advanced Fault Finding).	1	243	
Changes the Modbus range field to 50 and scaling of Pages 32 and 33 to a value of 3 (divides the returned value by 10)	19	240‡	
Synchronizes the time and date with a local BACnet Time Master (York Talk 3 only).	20	239	
Sets the BACnet communications rate to 38.4 kbaud, No parity	21	238	
Returns MicroGateway to EPROM defaults. (Requires removal of JP7 and power disconnect.)	3	128	

‡ Effects Modbus communications from the CLIP only.

FINAL CHECKOUT LIST	YES	NO (If no, indicate why)
1) Is the unit installed according to the diagrams presented in this manual? (Indicate the chiller board number and Figure No.)		
2) Is the unit wired and grounded according to all local, state and country codes, NEC recommendations and the procedures recommended in this manual?		
3) What is the York Talk Chiller ID address of the chiller board? (This is set using either the rotary switch on the chiller board or via software.)		
4) What is the node address of the MicroGateway? What is the node address of the CLIP, if installed?		
5) What was the LED flash rate when the node switch was to the Quick Start address?		
6) Do the RX and TX LEDs to the micro panel flash alternately, indicating York Talk communications?		
7) Is the third-party Controls Contractor connected properly to the correct port?		
8) Is the third-party Controls Contractor able to communicate to the MicroGateway successfully?		
9) What York Talk Points List has been provided to the third-party Controls Contractor? (http://intranet.york.com/web0147/) Include file name, revision level, and Modbus/BACnet map< if applicable.		

4

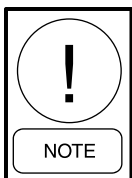

NOTE: *It is recommended that this page be photocopied before completion and a copy left at the jobsite for reference.*

If the answer to any of the above questions is no, indicate why in the space provided.

JOB NAME _____

STARTUP DATE _____

TECHNICIAN _____



P.O. Box 1592, York, Pennsylvania USA 17405-1592
Tele. 800-861-1001 website: www.york.com
Copyright © by York International Corporation 2005
Form 450.20-N14 (905)
Supersedes 450.20-N14 (1203)

Unit 1, Red Shute Hill, Hermitage, Newbury, Berks RG18 9QL United Kingdom
Tele: +44 (0)1635 202200 e-mail: controls.sales@uk.york.com
Subject to change without notice. Printed in USA
ALL RIGHTS RESERVED