

ENGINEERING GUIDE

YORK® YZ Centrifugal Chiller

Form: 161.01-EG1 (0618)

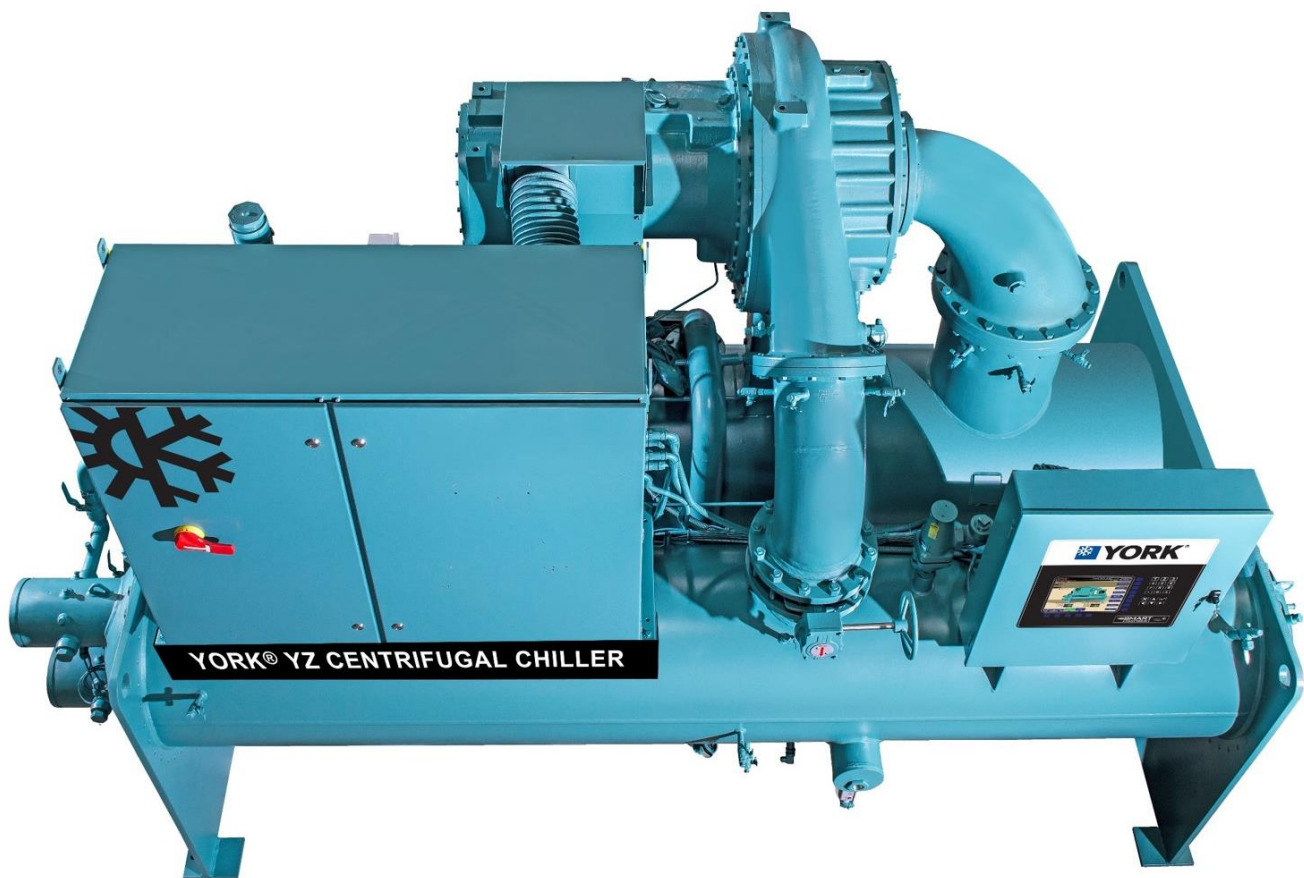

MODEL YZ MAGNETIC BEARING CENTRIFUGAL CHILLER
Style A

580 through 3500 kW
(165 through 1000 Tons)
Utilizing R-1233zd

Table of Contents

Nomenclature.....	3
Introduction	4
Unit Components	6
Equipment Overview.....	8
Codes and Standards	14
Chiller Options	16
Application Data.....	17
Unit Weights & Dimensions.....	22

Visit [YORK.com/Next](https://www.york.com/next) for more information

Nomenclature

SYSTEM

YZ - MA033 AN030 P042N A

Product Family _____ Unit Mod Level _____
 Motor Name _____ VSD Name _____
 Compressor Name _____

MOTOR

MA 033 AA

Motor Family _____ Motor Configuration Level _____
 Motor Size Code _____

COMPRESSOR

AN 030NA - AA

Compressor Family _____ Compressor Configuration Level _____
 Compressor Size Code _____

VARIABLE SPEED DRIVE

P 042 NA C A - 6 6

VSD Family _____ Frequency _____
 VSD Size Code _____ Voltage _____
 Filter (N-no filter, H-harmonic filter) _____ Sediment Accumulator _____
 VSD Cooling _____

HEAT EXCHANGER

FA 21 12 - A2Z * - 2 CA 1 G LR B**

Heat Exchanger Family _____ Hinges _____
 Nominal Diameter _____ Nozzle Arrangement _____
 Nominal Length _____ Water Connection Type _____
 Bundle Code _____ Waterside DWP _____
 Tube Type _____ Waterbox Family _____
 _____ Number of Passes _____

Introduction

The YORK® YZ Magnetic Bearing Centrifugal Chiller is a revolutionary advancement that challenges everything about conventional chiller design. The result is a chiller fully optimized for ultimate performance with a next generation low-GWP (global warming potential) refrigerant, delivering superior real-world performance and a new definition of sustainability. The YORK® YZ Chiller is available from multiple global factories to meet regional customers' needs.

EFFICIENCY

Johnson Controls pioneered the term “real-world efficiency” to illustrate the energy-saving potential of focusing on chiller performance during off-design conditions. Off-design conditions are not only seen at part-load, but at full-load operation as well, by taking advantage of reduced entering condenser water temperatures (ECWTs). These conditions are where chillers operate up to 99% of the time, and where operating costs add up. YZ chillers are designed to operate on a continuous basis with cold ECWT and full condenser flow at all load points, taking full advantage of real-world conditions. YZ chillers offer the most efficient real-world operation of any chiller, meaning lower operating costs and an excellent return on your chiller investment.

Actual chiller efficiency cannot be determined by analyzing the theoretical efficiency of any one chiller component. It requires a specific combination of heat exchanger, compressor, and motor performance to achieve the best system efficiency. YZ technology matches chiller system components to provide maximum chiller efficiency under actual – not just theoretical – operating conditions. Now with the YORK® YZ, efficiency is improved up to an impressive 7% at part-load and as much as an additional 5% at full-load versus our most efficient previous designs.

BETTER EFFICIENCY IN EVERY OPERATING CONDITION

The YZ chiller has been designed to take full advantage of colder cooling tower water temperatures, which are naturally available during most operating hours. Considerable energy savings are available by letting tower water temperature drop, rather than artificially holding it above 19°C (65°F), especially at low load, as some chillers require.

Since the vast majority of its operating hours are spent at off-design conditions, a chiller should be chosen not only to meet the full-load design, but also for its ability to perform efficiently at lower loads, lower tower water temperatures, and even higher leaving evaporator water temperatures. It is not uncommon for chillers with the same full-load efficiency to have an operating cost difference of over 10% due to differences in part-load efficiencies.

Part-load is important to an owner's operating budget, this information has been standardized within the AHRI Certification Program in the form of an Integrated Part Load Value (IPLV), and Non-Standard Part Load Value (NPLV).

Additionally, looking at annual energy costs that use weather data specific to your city, you can get a better understanding of the efficiency benefits the YORK® YZ offers across a wide range of operating conditions. This more detailed analysis also takes into account actual building load profiles to provide a more accurate view of chiller operating cost. Part-load performance data should be requested by the customer for each job using its own design criteria.

RELIABILITY

Designed for the most reliable chillers we have ever made, the YORK® YZ magnetic bearing compressor achieves superior performance because it is based on a successful line of efficient YORK® compressors. With fewer moving parts, YORK® compressors have proven to be durable in numerous applications, especially where minimal downtime is a critical concern. The lubrication-free, non-contact design of the YORK® YZ provides system simplicity and reliability that far exceeds continuous-contact-oil and refrigerant-lubricated bearing chiller designs.

The majority of chiller components on YZ chillers have been time tested on the tens of thousands of air-cooled and water-cooled YORK® chillers operating globally. The YZ chiller employs the most advanced driveline available - an active magnetic-bearing drive to levitate the driveshaft. The result is frictionless operation and 80% fewer moving parts than oil-lubricated or refrigerant-lubricated systems, which is why we have used this type of driveline in our mission-critical chillers since 1998.

The YZ chiller incorporates service design principles that are consistent with our family of centrifugal chillers. We made sure that this chiller, and specifically the driveline, was field serviceable by a single source supplier, who also happens to be the industry's largest service force: our own Johnson Controls service team.

AHRI CERTIFICATION PROGRAM

The performance of the YZ chiller has been certified by the Air Conditioning, Heating and Refrigeration Institute (AHRI) as complying with the certification sections of the latest issue of AHRI Standard 550/590. Under this Certification Program, chillers are regularly tested in strict compliance with this Standard. This provides an independent, third-party verification of chiller performance.



COMPUTERIZED PERFORMANCE RATINGS

Each chiller is custom-matched to meet the individual building load and energy requirements. A variety of standard heat exchangers and pass arrangements are available to provide the best possible match.

It is not practical to provide tabulated performance for each combination, as the energy requirements at both full- and part-load vary significantly with each heat exchanger and pass arrangement. Computerized ratings are available through each Johnson Controls sales office. Each rating can be tailored to a specific job requirement, and is part of the AHRI Certification Program.

Unit Components

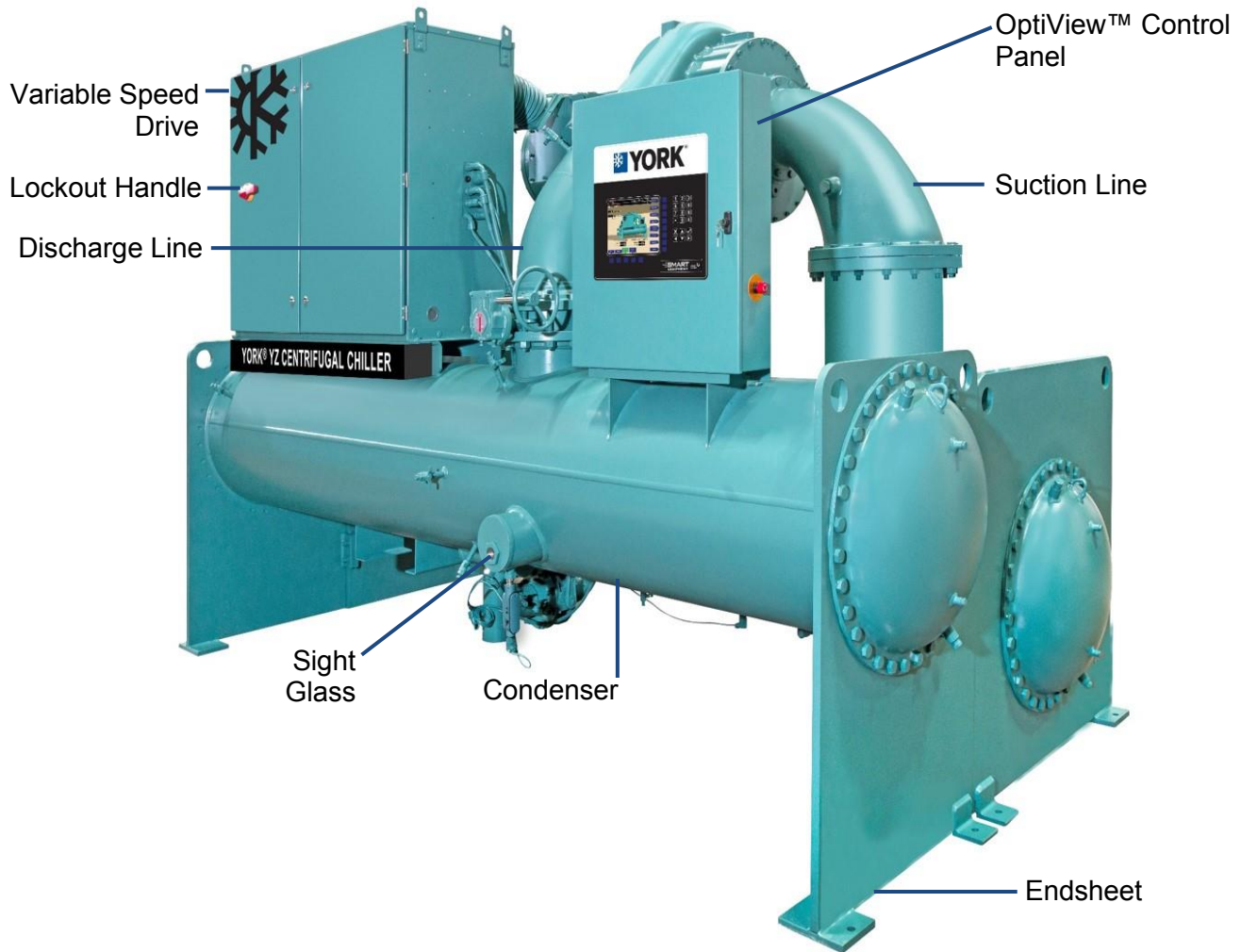

Unit Components (Continued)

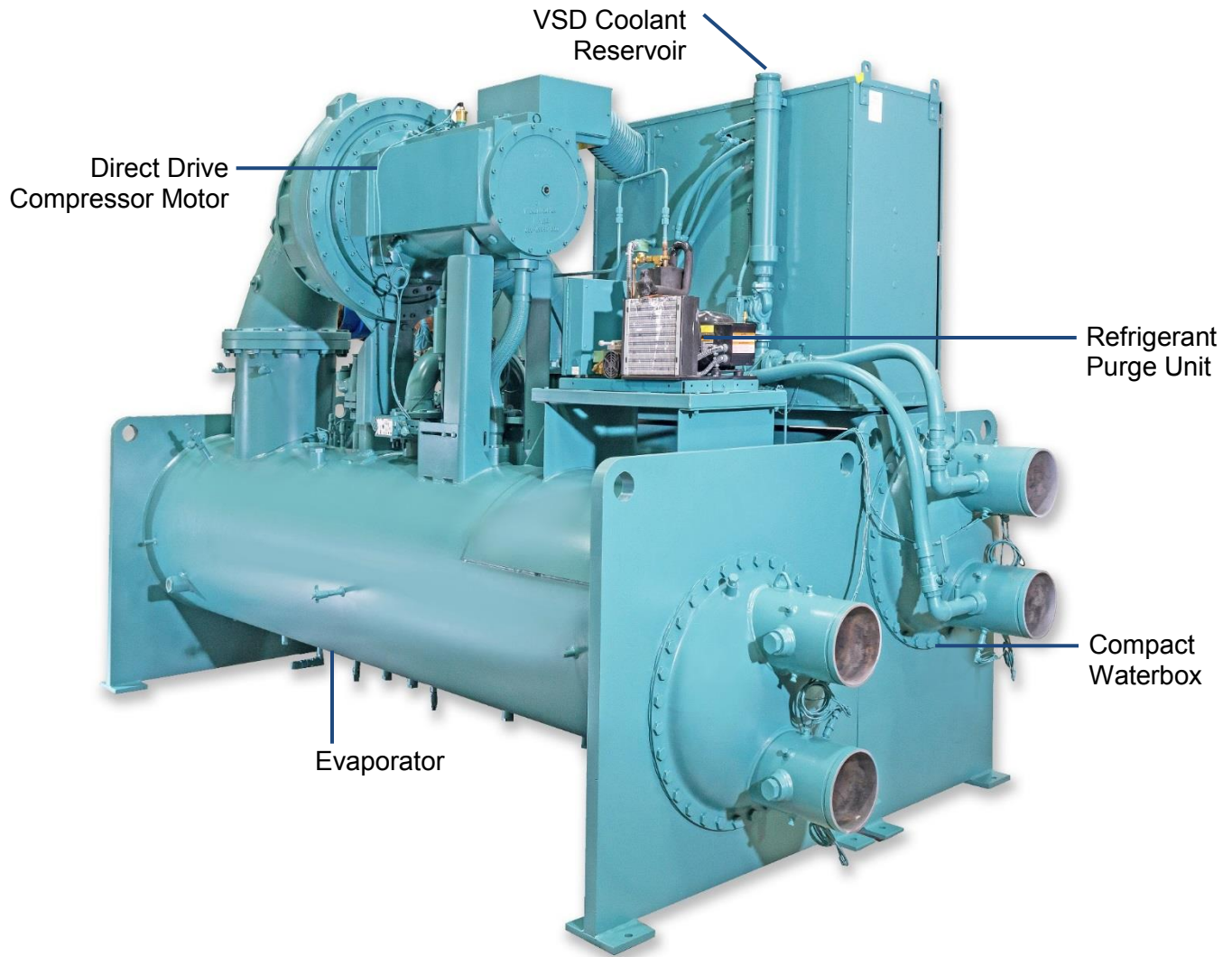

Equipment Overview

YORK® YZ Centrifugal Chillers are completely factory-packaged including the compressor, motor, VSD, OptiView™ control center, evaporator, condenser, purge unit, and all interconnecting unit piping and wiring.

When selected, the initial charge of refrigerant can be supplied for each chiller from the factory. Actual shipping procedures for the chiller will depend on a number of project-specific details. YZ chillers are designed to keep installation costs low. Where installation access is not a problem, the unit can be shipped completely packaged including the unit-mounted variable speed drive, requiring minimal piping and wiring to complete the installation.

At start-up, the services of a Johnson Controls factory-trained, field service representative are required to supervise or perform the final leak testing, charging, initial start-up, and concurrent operator instructions.

COMPRESSOR

Note: Please refer to the YZ Operations & Maintenance Manual (161.01-OM1) for a complete description of features and functionality.

The compressor is a single-stage centrifugal design directly driven by a hermetically-sealed motor with a VSD. A cast-aluminum, fully-shrouded impeller is mounted directly to the motor shaft. Impeller seals employ a labyrinth geometry, sized to provide minimal thrust loading on the impeller throughout the operating range. The impeller is dynamically balanced and overspeed tested for smooth, vibration-free operation.

CAPACITY CONTROL

Capacity control is achieved by the combined use of variable speed control and mechanical flow regulation to provide fully modulating control from maximum to minimum load. For normal air conditioning applications, the chiller can adjust capacity from 100% to 10% of design, without the use of hot gas bypass (HGBP). For each condition, the capacity control devices will be automatically adjusted to maintain a constant leaving chilled liquid temperature at optimized efficiency, based on information fed by sensors located throughout the chiller.

YZ chillers are equipped with sophisticated capacity control as standard. Our capacity control is a patented combination of centrifugal chiller hardware and software that expands the chiller operating range and improves chiller performance. The capacity control continuously monitors the characteristics of the compressor discharge gas and optimizes the diffuser spacing to minimize gas-flow disruptions from the impeller.

MOTOR

The compressor motor is a hermetically-sealed, high-speed induction motor supported by active magnetic bearings. The bearing design provides a completely lubrication-free operating system. The motor rotor and stator are cooled by a pressure driven refrigerant loop to maintain acceptable operating temperatures.

The active magnetic bearings are equipped with balancing systems to ensure smooth and reliable operation. In the event of a power failure, the magnetic bearings will remain in operation throughout the compressor coast-down using an uninterruptable power supply. Mechanical bearings are included as backup to the magnetic bearings and are designed for rare emergency touchdown situations where both the main power and uninterruptable power supply fail.

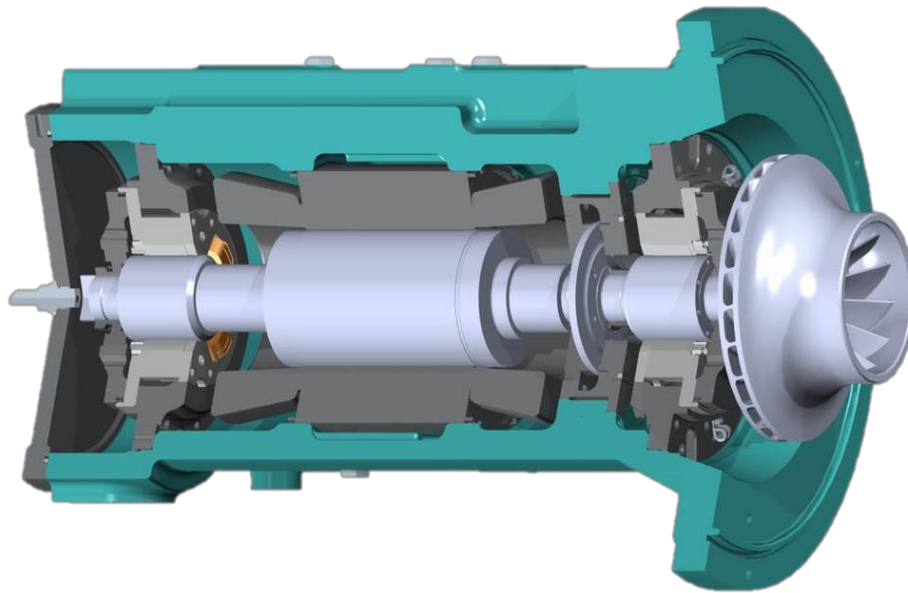

VARIABLE SPEED DRIVE

Note: Please refer to the YZOperations & Maintenance Manual (161.01-OM1) for a complete description of features and functionality.

A variable speed drive is factory-packaged and mounted on the YZ chiller. It is designed to vary the compressor motor speed by controlling the frequency and voltage of the electrical power to the motor. The capacity control logic shall automatically adjust motor speed and compressor diffuser geometry for maximum part load efficiency by analyzing information fed to it by sensors located throughout the chiller. The variable speed drive is mounted in a NEMA-1/IP22 enclosure with all power and control wiring between the drive and chiller factory-installed. The chiller uses a single-point power connection with a circuit breaker disconnect. Electrical lugs for incoming power wiring are provided.



The variable speed drive provides automatic displacement power factor correction to 0.95 or better at all load conditions. Separate displacement power factor correction capacitors are not required. The displacement power factor is 0.98 or better when the optional harmonic filter is provided. Additionally, variable speed drives provide the following advantages:

- Lowest chiller operating cost through part load energy savings.
- Soft start with input current less than full load current.
- Smooth acceleration reduces stresses on motor and driveline.
- Rugged and reliable with no moving parts.

Standard features include: a door interlocked lockable circuit breaker; UL/cUL listed and CE approved ground fault protection; over-voltage and under-voltage protection; 3-phase sensing motor over-current protection; single-phase protection; insensitive to phase rotation; over-temperature protection and readouts of important values on the OptiView™ control panel.

OPTIVIEW™ CONTROL CENTER

Note: Please refer to the YZ Operations & Maintenance Manual (161.01-OM1) for a complete description of features and functionality.

The YORK® OptiView™ Control Center is a factory mounted, wired and tested microprocessor based control system for centrifugal chillers. It provides control of chiller operation and monitoring of chiller sensors, actuators, relays and switches. As part of the capacity control logic, OptiView™ controls the leaving chilled liquid temperature and adjusts the motor current via control of the Variable Geometry Diffuser (VGD) and Variable Speed Drive (VSD).



The panel comes configured with a full screen graphic display mounted in the middle of a keypad interface with soft keys. The operator may view a graphical representation of the historical operation of the chiller as well as the present operation. The locations of various chiller parameters are clearly marked, and instructions for specific operations are provided on many of the screens. To prevent unauthorized changes of setpoints and operating conditions, security access is provided with three different levels of access and passwords.

The graphic display also allows information to be represented in both SI and Imperial units of measure, and has the ability to display many languages.

OptiView™ continually monitors the system operation and records the cause of any shutdowns (safety, cycling or normal). This information is recorded in memory and is preserved even through a power failure condition, so the user may recall it for viewing at any time. During operation, the user is continually advised of the operating conditions by various status and warning messages. By providing a common networking protocol through the Building Automation System (BAS), YORK® chillers not only work well individually, but also as a part of the building system. This networking protocol allows increased remote control of the chiller, as well as 24-hour performance monitoring via a remote site. In addition, compatibility is maintained with the present network of BAS communications. Both of these remote control capabilities allow for the standard Energy Management System (EMS) interface:

1. Remote Start
2. Remote Stop
3. Remote leaving chilled liquid temperature setpoint adjustment
4. Remote current limit setpoint adjustment
5. Pulse Width Modulation
6. Remote "Ready to Start" Contacts
7. Safety Shutdown Contacts
8. Cycling Shutdown Contacts

HEAT EXCHANGERS

Shells

Evaporator and condenser shells are fabricated from rolled carbon steel plates with fusion welded seams or carbon steel pipe. Carbon steel tube sheets, drilled and reamed to accommodate the tubes, are welded to the end of each shell. Intermediate tube supports are fabricated from carbon steel plates, and drilled and reamed to eliminate sharp edges. The refrigerant side of each shell is designed, tested, and stamped in accordance with local pressure vessel codes.

Tubes

Heat exchanger tubes are copper alloy high-efficiency, externally and internally enhanced to provide optimum performance. Utilizing the "skip-fin" tube design provides a smooth internal and external surface at each intermediate tube support. This provides extra wall thickness (up to twice as thick) and non work-hardened copper at the support location, extending the life of the heat exchangers. Each tube is expanded into the tube sheets providing a leak-proof seal, and is individually replaceable.

Evaporator

The evaporator is a patented hybrid falling-film type heat exchanger. It contains a balance of flooded and falling-film technology to optimize efficiency, minimize refrigerant charge, and maintain reliable control. A specifically designed spray header provides uniform distribution of refrigerant over the entire shell length to yield optimum heat transfer. A suction eliminator is located above the tube bundle to prevent liquid refrigerant carryover into the compressor. A 38 mm (1.5") liquid level sight glass is conveniently located on the side of the shell to aid in determining proper refrigerant charge. The evaporator shell contains a dual refrigerant relief valve arrangement or a single relief valve arrangement if the chiller is supplied with the optional refrigerant isolation valves. A 25.4 mm (1") refrigerant charging valve is provided for service access.

Condenser

The condenser is a shell and tube type heat exchanger with a discharge gas baffle to prevent direct high velocity impingement on the tubes. The baffle is also used to distribute the refrigerant gas flow properly for the most efficient heat transfer. An integral subcooler is located at the bottom of the condenser shell, providing highly effective liquid refrigerant subcooling to provide the highest possible cycle efficiency. A 38 mm (1.5") liquid level sight glass is conveniently located on the side of the shell to aid in determining proper refrigerant charge. The condenser contains dual refrigerant relief valves.

Waterboxes

The removable waterboxes are fabricated of steel. Integral steel water baffles are located and welded within the waterbox to provide the required pass arrangements. Stub-out water nozzle connections welded to the waterboxes are suitable for ANSI/AWWA C-606 couplings, welding or flanged, and are capped for protection during shipment. Plugged 19 mm (3/4") drain and vent connections are provided in each waterbox.

Water Flow Switches

Thermal or differential pressure type water flow switches are factory mounted in the evaporator and condenser water nozzles, and are factory wired to the OptiView™ control panel.

Refrigerant Flow Control

Refrigerant flow to the evaporator is controlled by the YORK® variable orifice control system. Liquid refrigerant level is continuously monitored to provide optimum subcooler, condenser and evaporator performance. The variable orifice electronically adjusts to all real-world operating conditions, providing the most efficient and reliable operation of refrigerant flow control without the use of a refrigerant pump.

Refrigerant Purge Unit

The purge is designed to meet the ASHRAE Standard 147 where at most one unit mass of refrigerant is purged per one unit mass of air removed by the unit. This automatic, self-contained, high-efficiency purge unit collects non-condensable gases to be removed from the chiller. The YORK® purge is factory assembled, mounted, piped, and wired, and operates automatically. Purge exhaust cycles are monitored, and if excessive, provide warning of a potential system leak to the OptiView™ Control Center.

ISOLATION MOUNTING

The unit is provided with four vibration isolation mounts of nominal 25.4 mm (1") operating height. The isolators have a neoprene pad to contact the foundation, bonded to a steel plate. The vibration isolation pad assemblies mount under steel plates welded to the chiller tube sheets.

Optionally, spring isolation mounting is available instead of standard isolation mounting pads. Four level-adjusting, spring-type vibration isolator assemblies with non-skid pads are provided for field-installation. Isolators are designed for 25.4 mm (1") of deflection.

REFRIGERANT CONTAINMENT

The standard unit has been designed as a complete factory-packaged chiller, which minimizes the joints from which refrigerant can leak. The entire assembly is thoroughly leak tested at the factory prior to shipment. The YZ chiller includes service valves conveniently located to facilitate transfer of refrigerant to a remote refrigerant storage/recycling system.

Optional factory-installed isolation valves in the compressor discharge line and refrigerant liquid line allow isolation and storage of the refrigerant charge in the chiller condenser.

FACTORY TESTING

Johnson Controls has the ability to factory performance test every type of chiller that we engineer and manufacture. Testing options, including performance, vibration, and sound, can be performed as factory or remote customer witness tests.

SMART EQUIPMENT

Smart Equipment by Johnson Controls allows the connection of data streams from equipment to the cloud, providing unprecedented insights into operations. Smart Equipment helps maximize system control for greater efficiency, extended equipment life and reduced operating costs. The YORK® YZ chiller has controls embedded at the factory to allow the chiller to connect seamlessly to a controls system. On-board controls that support cloud-based data analytics, including fault detection, enables proactive maintenance and minimizes downtime.

YORK® SMART CONNECTED CHILLERS

YORK® Smart Connected Chiller functionality feeds YZ chiller data to a secure, cloud-based dashboard, enabling analysis of historical data to diagnose the chiller, observe long-term trends, and investigate potential issues. The dashboard collects status-related data warnings, cycling, and safety fault codes. Advanced algorithms detect problems such as condenser or evaporator tube fouling or low refrigerant charge. A more strategic approach to maintenance can be implemented to stay a step ahead of emergencies to save time and money.

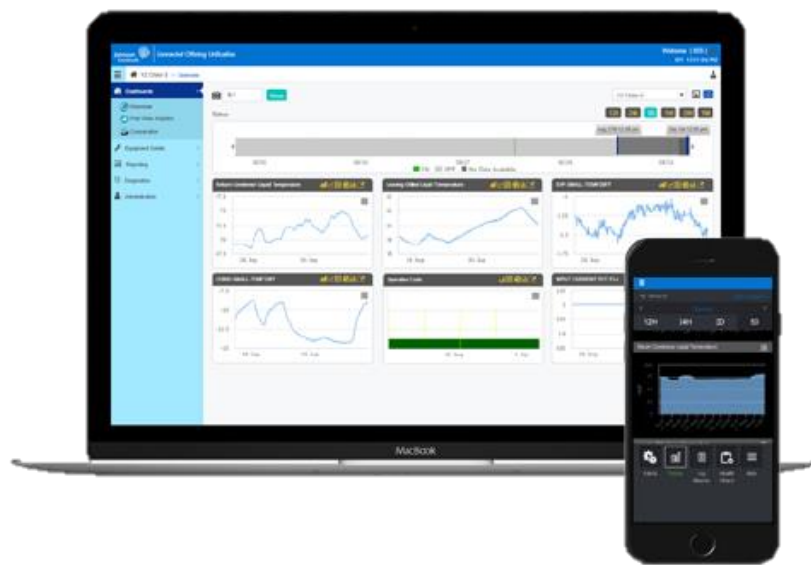

SHIPMENT

Each unit can be broken down into several form shipment configurations for ease of transportation and installation. For all broken down shipment options, the unit is first factory assembled, refrigerant piped, wired and leak tested; then disassembled according to the shipment option selected.

Protective covering is furnished on the OptiView™ and VSD. Water nozzles are capped with fitted plastic enclosures. Then the entire unit is protected with industrial-grade, reinforced shrink-wrap covering.

Form 1 – Unit is shipped as one assembly with refrigerant charge inside the unit.

Form 2 – Unit is shipped as one assembly with refrigerant charge shipped separately.

Form 3 – Driveline separate from shells. Shipped as three major subassemblies with refrigerant charge shipped separately. This form is best used when height is a limiting dimension to enter the installation site.

- Driveline (motor/compressor assembly)
- Evaporator/Condenser shell assembly – not skidded
- Variable Speed Drive

Form 7 – Driveline separate from split shells. Shipped as four major subassemblies, with refrigerant charge shipped separately. This form is best used when the chiller must fit through a tight space, limited by multiple dimensions.

- Driveline (motor/compressor assembly)
- Evaporator – not skidded
- Condenser – not skidded
- Variable Speed Drive

Form 11 – Unit shipped as two major subassemblies, with refrigerant charge shipped separately. This form is best used when width is a limiting dimension to enter the installation site.

- Condenser side assembly (Condenser/OptiView™/Variable Speed Drive) – not skidded
- Evaporator side assembly (Evaporator/Driveline/Magnetic Bearing Controller) – not skidded

Codes and Standards

Chiller standards and codes vary based on factory source. Any of the standards and codes listed below can be met when ordering the YZ chiller. Work with your local sales contact for a unit that will meet your local codes and standards.

PERFORMANCE & ENERGY STANDARDS

- ASHRAE 90.1
- AHRI Standard 550/590
- IECC – International Energy Conservation Code
- GBCI – Green Business Certification Inc.
- Eurovent (EN14511, EN14825)
- GB 18430.1
- GB 19577/GB 50189
- GB/T 50378
- MEPS – Minimum Energy Performance Standards
- ECBC – Energy Conservation Building Code
- Greenmark

- BEC – Business Environment Council
- SASO – Saudi Standards, Metrology and Quality Organization
- ESMA – Emirates Authority for Standardization and Metrology
- LEED EA4 enhanced refrigerant management credit
- BREEAM Refrigerant Credit – Building Research Establishment Environmental Assessment Method

SOUND RATINGS

- AHRI 575
- ISO 9614/3744
- JB/T 4330

PRESSURE VESSEL CODES

- ASME Boiler and Pressure Vessel Code – Section VII – Division I
- PED – European Pressure Equipment Directive
- NB/T 47012
- KHK – High Pressure Gas Control Law

ELECTRICAL CODES

- c/U.L. – Underwriters Laboratory
- N.E.C. – National Electrical Code
- CE – Directive 93/68/EEC
- IP – Ingress Protection
- GB 5226.1
- ETL – Electrical Testing Labs

SAFETY CODES

- ASHRAE 15 – Safety Code for Mechanical Refrigeration
- ASME
- Safety Code for Mechanical Refrigeration (EN 378-2/A2)
- Machinery Directive (2006/42/EC)
- EMC Directive (2004/108/EC)
- Safety of machinery – Electrical Equipment of Machine (EN 60204-1)
- GB 25131

MANUFACTURING REQUIREMENTS

- Manufactured in an EN ISO 9001 accredited organization
- Conform to CE Testing Services for construction of chillers and provide CE listed mark
- EN 61000-6-2:2005 and EN 61000-6-4:2007 compliance for use in an industrial environment

Chiller Options

ITEM	DESCRIPTION	STANDARD	OPTIONAL
VSD	Harmonic Filter	None	Input harmonic filter
	Incoming customer wiring	60 Hz: 460V, 400V, 380V 50 Hz: 415V, 400V, 380V	
	VSD cooling heat exchanger protection (for condenser fluid lines)	None	Sediment accumulator
Heat Exchangers	Tube wall thickness	0.635 mm (0.025")	0.711 mm and 0.889 mm (0.028" and 0.035")
	Factory tube testing	None	Factory Eddy current testing
	Evaporator thermal insulation	None	19 mm, 25.4 mm ¹ , 32 mm ² , and 38 mm (3/4", 1", 1.25", 1.5") standard thickness
Waterboxes	Customer piping connections	Grooved	Flanges
	Waterbox design	Compact	Marine
	Design working pressure	1034 kPa (150 psig) DWP	2070 kPa (300 psig) DWP
	Hinges	None	1034 kPa & 2070 kPa (150 psig & 300psig) DWP
	Corrosion protection	None	Internally epoxy coated waterboxes and tubesheets, sacrificial anodes
Unit Configuration	Ability to isolate refrigerant charge in the condenser	None	Isolation valves
	Minimum load (assuming AHRI unloading)	Down to 10% unloading	Down to 0% with hot gas bypass
	Unit mount	Neoprene pads	Spring isolation
	Flow switches in the evaporator and condenser water nozzles	Thermal flow switch or differential pressure flow switch ³	Ship loose paddle flow switches
	Unit paint	Caribbean blue paint	Amerlock 400, Amershield
	Factory knock-down shipment options	Form 1 or 2 ⁴	Form 3, 7, or 11
	Unit wrapped before shipment	Partial wrapping (driveline & electrical)	Complete chiller wrapping
	Temporary shipping skids	None	Shipping skids
	Long term storage requirements	None	Long term storage

Contact your local sales representative for more information.

¹ Asia-source only

² Europe-source only

³ Asia-source standard

⁴ Europe-source standard

Application Data

The following is a guide to the application of YZ chillers to ensure reliable operation. While this guide is directed towards normal, water-chilling applications, a Johnson Controls sales engineer can provide complete recommendations on other types of applications.

LOCATION

YZ chillers are virtually vibration free and may generally be located at any level in a building where the construction will support the total system operating weight.

The unit site must be a floor, mounting pad or foundation which is level within 6.5 mm (1/4") and capable of supporting the operating weight of the unit.

Sufficient clearance to permit normal service and maintenance work should be provided all around and above the unit. Additional space should be provided at one end of the unit to permit cleaning of evaporator and condenser tubes as required. A doorway or other properly located opening may be used if convenient.

The chiller should be installed in an indoor location where temperatures range from 4.4°C to 40.0°C (40°F to 104°F). The dew point temperature in the equipment room must be below the entering condenser water temperature to prevent condensing water vapor inside of the VSD. Other areas susceptible to water vapor condensate are outside of the condenser shell and condenser waterboxes. Example applications include cooling condenser water using chilled water, wells, river, or other low temperature fluids.

Refrigerant Relief Piping - Each chiller is equipped with dual pressure relief valves on the condenser and two dual relief valves on the evaporator, or two single relief valves on the evaporator if the optional refrigerant isolation valves are ordered. The dual relief valves on the condenser are redundant and allow changing of either valve while the unit is fully charged. The purpose of the relief valves is to quickly relieve excess pressure of the refrigerant charge, as a safety precaution in the event of an emergency such as a fire. They are set to relieve at an internal pressure as noted on the pressure vessel data plate, and are provided in accordance with local pressure vessel codes.

Sized to the requirements of applicable codes, a vent line must run from the relief device to the outside of the building. This refrigerant relief piping must include a cleanable, vertical leg dirt trap to catch vent-stack condensation. Vent piping must be arranged to avoid imposing a strain on the relief connection and should include one flexible connection.

Sound and Vibration Considerations - A YZ chiller is not a source of objectionable vibration in most air conditioning applications. Standard neoprene isolation mounts are available with each unit to reduce vibration transmission. Optional level-adjusting spring isolator assemblies designed for 25.4 mm (1") static deflection are also available for further isolation. YZ chiller sound pressure level ratings will be provided upon request. Control of sound and vibration transmission must be taken into account in the equipment room construction as well as in the selection and installation of the equipment.

Thermal Insulation - The chiller's cold surfaces should be insulated with a vapor barrier insulation sufficient to prevent condensation. As an option, a chiller can be factory-insulated. This insulation will normally prevent condensation in environments with dry bulb temperatures of 10.0°C to 32.2°C (50°F to 90°F) and relative humidity up to 75% [19 mm (3/4") thickness], 85% [25.4 mm (1") thickness], or 90% [38 mm (1.5") thickness]. It is intended for a chiller installed indoors and, therefore, no protective covering of the insulation is usually required. If insulation is applied to the waterboxes at the job site, it must be removable to permit access to the tubes for routine maintenance.

Ventilation - Some standards requires that all machinery rooms be vented to the outdoors utilizing mechanical ventilation by one or more fans. State, local and any other related codes should be reviewed for specific requirements. Since the YZ chiller motor is hermetically sealed, no additional ventilation is needed due to motor heat.

In addition, the ASHRAE Standard 15 requires a refrigerant vapor detector to be employed for all refrigerants. It is to be located in an area where refrigerant from a leak would be likely to concentrate. An alarm is to be activated and the mechanical ventilation started at a value no greater than the Threshold Limit Value (TLV) of the refrigerant.

WATER CIRCUITS

Flow Rate - For normal water chilling duty, evaporator and condenser flow rates are permitted at water velocity levels in the heat exchanger tubes of between 0.91m/s and 3.66m/s (3.0 fps and 12.0 fps) for evaporators and 1.0m/s and 3.66m/s (3.3 fps and 12.0 fps) for condensers. Two pass units are also limited to 134kPa (45ft H₂O) water pressure drop. The three pass limit is 201kPa (67.5ft H₂O). Variable flow in the condenser is not recommended, as it generally raises the energy consumption of the system by keeping the condenser pressure high in the chiller. Additionally, the rate of fouling in the condenser will increase at lower water velocities associated with variable flow, raising system maintenance costs. Cooling towers typically have narrow ranges of operation with respect to flow rates, and will be more effective with full design flow.

The chillers can tolerate a 50% flow rate change in one minute that is typically associated with the staging on or off of an additional chiller; however a lower flow rate change is normally used for better system stability and set point control. Proper sequencing via the building automation system will make this a very smooth transition.

Variable Primary Flow - There is increasing interest to use variable primary flow (VPF) systems in large chilled water plants. VPF systems can offer lower installation and operating costs in many cases, but do require more sophisticated control and flow monitoring. YZ chillers will operate successfully in VPF systems. With a minimum allowable evaporator tube velocity of 0.5m/s (1.5 fps) for standard tubes at part load rating conditions, YZ chillers will accommodate the wide variation in flow required by many chilled water VPF applications.

Temperature Ranges - For normal water chilling duty, leaving chilled water temperatures may be selected between 3.5°C (38°F) and 21.0°C (70°F) to obtain temperature deltas between entering chilled and leaving chilled water temperature of 1.7°C up to 16.7°C (3°F up to 30°F).

Water Quality - The practical and economical application of liquid chillers requires that the quality of the water supply for the condenser and evaporator be analyzed by a water treatment specialist. Water quality may affect the performance of any chiller through corrosion, deposition of heat-resistant scale, sedimentation or organic growth. These will degrade chiller performance and increase operating and maintenance costs. Normally, performance may be maintained by corrective water treatment and periodic cleaning of tubes. If water conditions exist which cannot be corrected by proper water treatment, it may be necessary to provide a larger allowance for fouling, and/or to specify special materials of construction.

General Piping - All chilled water and condenser water piping should be designed and installed in accordance with accepted piping practice. Chilled water and condenser water pumps should be located to discharge through the chiller to assure positive pressure and flow through the unit. Piping should include offsets to provide flexibility and should be arranged to prevent drainage of water from the evaporator and condenser when the pumps are shut off. Piping should be adequately supported and braced independently of the chiller to avoid the imposition of strain on chiller components. Hangers must allow for alignment of the pipe. Isolators in the piping and in the hangers are highly desirable in achieving sound and vibration control.

Convenience Considerations - To facilitate the performance of routine maintenance work, some or all of the following steps may be taken by the purchaser. Evaporator and condenser waterboxes are equipped with plugged vent and drain

connections. If desired, vent and drain valves may be installed with or without piping to an open drain. Pressure gauges with stop-cocks and stop-valves may be installed in the inlets and outlets of the condenser and chilled water line as close as possible to the chiller. An overhead monorail or beam may be used to facilitate servicing.

Connections - The standard chiller is designed for 1034 kPa (150 psig) design working pressure in both the chilled water and condenser water circuits. The connections (water nozzles) to these circuits are furnished with grooves to ANSI/AWWA C-606 standard for grooved and shouldered joints. Piping should be arranged for ease of disassembly at the unit for tube cleaning. All water piping should be thoroughly cleaned of all dirt and debris before final connections are made to the chiller.

Chilled Water - A water strainer of maximum 3.2 mm (1/8") perforated holes must be field-installed in the chilled water inlet line as close as possible to the chiller. If located close enough to the chiller, the chilled water pump may be protected by the same strainer. The strainer is important to protect the chiller from debris or objects which could block flow through individual heat exchanger tubes. A reduction in flow through tubes could seriously impair the chiller performance or even result in tube freeze-up. A flow switch is factory installed in the evaporator nozzle and connected to the OptiView™ panel, which assures adequate chilled water flow during operation.

Condenser Water - The chiller is engineered for maximum efficiency at both design and part load operation by taking advantage of the colder cooling tower water temperatures which naturally occur during the winter months. Appreciable power savings are realized from these reduced heads. At initial startup, entering condensing water temperature may be as much as 16.7°C (30°F) colder than the standby chilled water temperature.

MULTIPLE UNITS

Selection - Many applications require multiple units to meet the total capacity requirements as well as to provide flexibility and some degree of protection against equipment shutdown. There are several common unit arrangements for this type of application. The YZ chiller has been designed to be readily adapted to the requirements of these various arrangements.

Parallel Arrangement - Chillers may be applied in multiples with chilled and condenser water circuits connected in parallel between the units. Figure 1 below represents a parallel arrangement with two chillers. Parallel chiller arrangements may consist of equally or unequally sized units. When multiple units are in operation, they will load and unload at equal percentages of design full load for the chiller.

Figure 1 – Parallel Evaporators (Evap.) Parallel Condensers (Cond.)

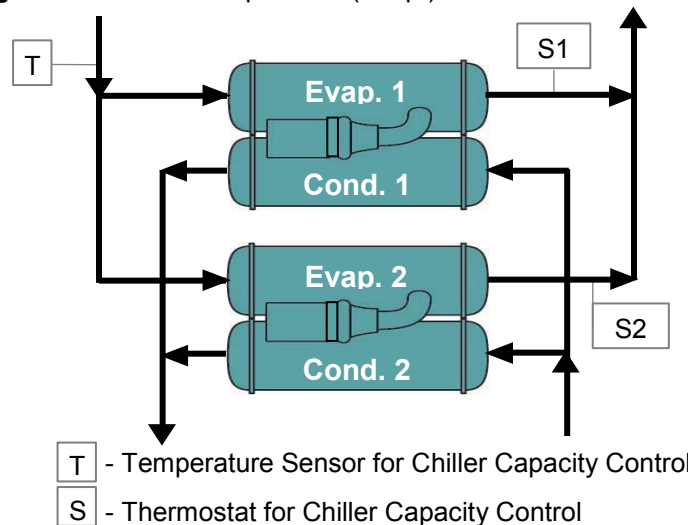

Depending on the number of units and operating characteristics of the units, loading and unloading schemes should be designed to optimize the overall efficiency of the chiller plant. It is recommended to use an evaporator bypass piping arrangement to bypass fluid around evaporator of any unit which has cycled off at reduced load conditions. It is also recommended to alternate the chiller cycling order to equalize chiller starts and run hours.

Series/Parallel Arrangement - Chillers may be applied in pairs with chilled water circuits connected in series and condenser water circuits connected in parallel. All of the chilled water flows through both evaporators with each unit handling approximately half of the total load. When the load decreases to a customer selected load value, one of the units will be shut down by a sequence control. Since all water is flowing through the operating unit, that unit will cool the water to the desired temperature.

Figure 2 – Series/Parallel Arrangement

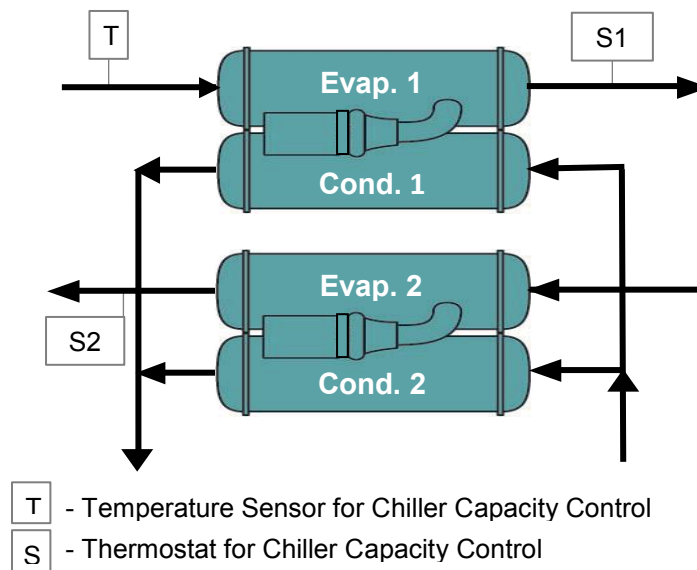

Series Counter Flow Arrangement - Chillers may be applied in pairs with chilled water circuits connected in series and with the condenser water in series counter flow. All of the chilled water flows through both evaporators. All of the condenser water flows through both condensers. The water ranges are split, which allows a lower temperature difference or "head" on each chiller, than multiple units in parallel. For equal chillers, the machine at the higher temperature level will typically provide slightly more than half the capacity. The compressor on each chiller is often matched, such that the high temperature machine can operate at the low temperature conditions when one unit is cycled off at part load (as compared to series-parallel chillers which are typically not identical).

Figure 3 – Series Evaporators (Evap.) Series-Counter Flow Condensers (Cond.)

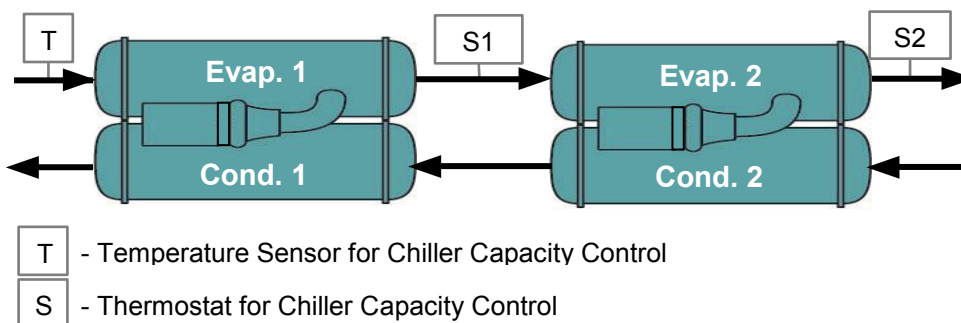

ELECTRICAL CONSIDERATIONS

Unit input conductor size must be in accordance with applicable electrical codes, for the unit full load amperes (FLA). Please refer to the submittal drawings for the FLA and Minimum Current Ampacity (MCA) specific to each application. Flexible conduit should be used for the last several feet to the chiller in order to provide vibration isolation. The table below lists the allowable variation in voltage supplied to the chiller. The unit nameplate is stamped with the unit voltage and frequency.

Voltage Variations

Frequency	Rated Voltage (Volts)	Nameplate Voltage (Volts)	Operating Voltage (Volts)	
			Min	Max
60 Hz	460	460	414	508
	400	400	360	440
	380	380	342	423
50 Hz	415	415	374	456
	400	400	360	440
	380	380	342	423

Copper Conductors - Only copper conductors should be connected to compressor motors and starters. Aluminum conductors have proven to be unsatisfactory when connected to copper lugs. Aluminum oxide and the difference in thermal conductivity between copper and aluminum cannot guarantee the required tight connection over a long period of time.

Displacement Power & Factor Correction Capacitors - The VSD provides automatic displacement power factor correction to a minimum of 0.95 at all operating conditions, so additional capacitors are not required.

Branch Circuit Overcurrent Protection - The branch circuit overcurrent protection device(s) should be a time-delay type, with a minimum rating equal to the next standard fuse/breaker rating above the calculated value. Refer to the submittal drawings for the specific calculations for each application.

Unit Weights & Dimensions

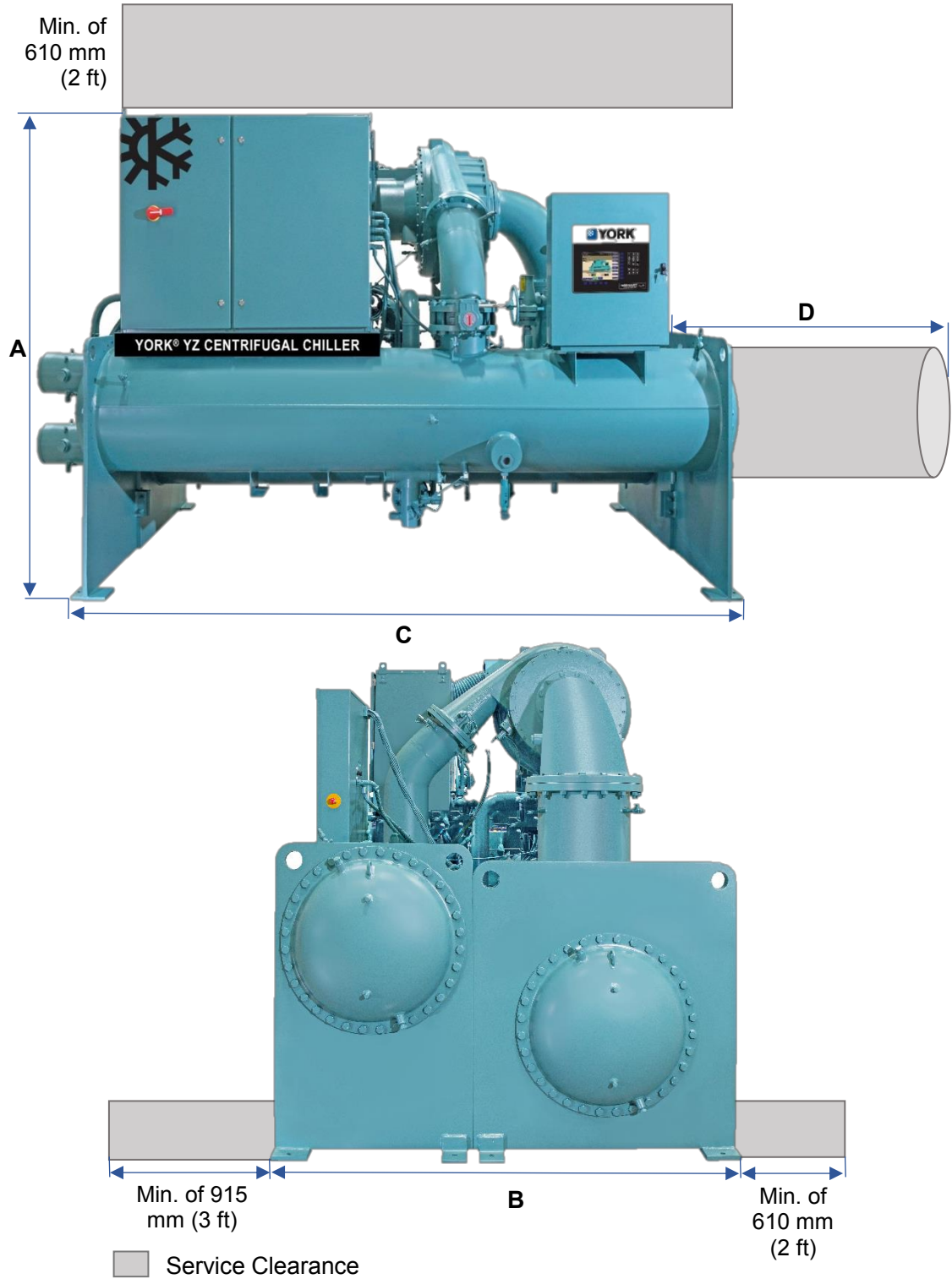

Unit Weights & Dimensions (Continued)⁵

Heat Exchanger Size	A - Height	B - Width	C - Length ⁶	D - Tube Removal Clearance	Maximum Shipping Weight ⁷
FB2910/CA2110	2.3 m (7.4')	1.8 m (5.9')	3.1 m (10')	3.1 m (10')	5950 kg (13100 lb)
FB2912/SA2512	2.4 m (7.9')	1.9 m (6.2')	3.7 m (12')	3.7 m (12')	7650 kg (16850 lb)
FA3312/SA2512	2.5 m (8.2')	2.1 m (6.9')	3.7 m (12')	3.7 m (12')	8600 kg (18300 lb)
FA3312/CA2512	2.6 m (8.5')	2.1 m (6.9')	3.7 m (12')	3.7 m (12')	8850 kg (19500 lb)
FA3314/SA3314	2.8 m (9.2')	2.3 m (7.5')	4.3 m (14')	4.3 m (14')	10900 kg (24000 lb)
FA3914/SA3314	2.9 m (9.4')	2.4 m (7.9')	4.3 m (14')	4.3 m (14')	11750kg (25900 lb)
FA3914/CA3314	3.1 m (10.0')	2.4 m (7.9')	4.3 m (14')	4.3 m (14')	12800 kg (28200 lb)
FA3916/SA3916	3.3 m (10.7')	2.6 m (8.5')	4.9 m (16')	4.9 m (16')	16050 kg (35350 lb)
FB4816/SA3916	3.4 m (11.2')	2.9 m (9.3')	4.9 m (16')	4.9 m (16')	18250 kg (40250 lb)
FB4816/CA3916	3.5 m (11.4')	2.9 m (9.3')	4.9 m (16')	4.9 m (16')	20100 kg (44350 lb)
FB4818/SA4418	3.9 m (12.5')	3.1 m (10.0')	5.5 m (18')	5.5 m (18')	23000 kg (50700 lb)
FB5618/SA4418	4.0 m (13.0')	3.4 m (10.9')	5.5 m (18')	5.5 m (18')	25450 kg (56100 lb)

⁵ Actual weights and dimensions for specific configurations can be provided by your local sales representative

⁶ Length (C) does not include length of waterboxes

⁷ Shipping Weight does not include refrigerant, which varies based on design condition



Visit [YORK.com/Next](https://www.york.com/Next) to learn more



SAVE OUR NATURAL RESOURCES. THINK BEFORE YOU PRINT.
Copyright© by Johnson Controls 2017
Form: 161.01-EG1
Issue Date: June 2018
Supersedes: 161.01-EG1 (1217)

Subject to change without notice
ALL RIGHTS RESERVED WORLDWIDE