



YZ CENTRIFUGAL CHILLER

STARTUP CHECKLIST

Supersedes: 161.01-CL2 (118)

Form 161.01-CL2 (718)

STARTUP CHECKLIST

CUSTOMER: _____ LOCATION: _____

ADDRESS: _____ CUSTOMER ORDER NO: _____

PHONE: _____ JCI CONTRACT NO: _____

JOB NAME: _____

CHILLER MODEL NO: _____

UNIT SERIAL NO: _____

The work (as checked below) is in process and will be completed by: _____ / _____ / _____
MM DD YYYY

A. YORK CHILLER

- 1. Review *Installation Checklist (Form 161.01-CL1)* to ensure installation is complete.....
- 2. Attach a signed and completed copy of *Form 161.01-CL1*.....
- 3. Unit checked for shipping damage.....

NOTE: Any damage **MUST** be reported to Johnson Controls immediately for inspection.

Initials: _____

Company Name: _____

Date: _____

- 4. If applicable, monitoring alarm is:
 - a. Functional.....
 - b. Operational.....

- e. Liquid line isolation valve.....
- f. Hot gas bypass isolation valve (if hot gas is present).....
- g. All required motor liquid cooling valves.....
- h. Purge isolation valves.....
- 4. Verify the UPS battery type selector is in position AGM2.....
- 5. Glycol shipping solution in the VSD has been drained and replaced.....
- 6. VSD has been flushed with de-ionized water.....
- 7. VSD is filled with blue inhibited water (P/N 013-02987-000).....

B. GENERAL

- 1. Unit is charged with refrigerant.....
- 2. Pressures match refrigerant saturation for ambient temperature.....
- 3. Each of the following valves are open:
 - a. Evaporator pressure transducer isolation valve.
 - b. Condenser pressure transducer isolation valve.
 - c. Discharge pressure transducer (stall transducer) isolation valve.....
 - d. Compressor discharge isolation valve.....

C. REFRIGERANT RELIEF PIPING (When Required)

- 1. Refrigerant relief piping installed from unit to atmosphere (per local building code).....
- 2. Purge exhaust must be piped to the refrigerant relief piping.....

D. ELECTRICAL WIRING

- 1. Incoming power wiring is NOT aluminum.....
- 2. Incoming power wire is sized correctly for the VSD. Refer to *161.01-PW3*.....
- 3. Variable Speed Drive (VSD):
 - a. Main power supply available.....

- b. Wiring completed from main power supply up to VSD
- NOTE:** DO NOT cut to length or connect to the drive without JCI supervision.
- c. Power feed terminations to the VSD are tightened to torque value listed on the circuit breaker.
- d. The circuit breaker settings match the settings shown in the *OptiSpeed VSD Service Manual (161.01-M3)*
- 4. External control wiring completed according to the wiring diagram shipped with the unit.
- 5. Chilled water pumps:
 - a. Power is available.....
 - b. Wiring is complete
 - c. Check rotation
- 6. Condenser water pumps:
 - a. Power is available.....
 - b. Wiring is complete
 - c. Check rotation
- 7. Cooling tower fan:
 - a. Power is available.....
 - b. Wiring is complete
 - c. Check rotation
- NOTE:** DO NOT check compressor motor.
- 8. Megohm tester available for checking motor windings.
- NOTE:** Tester not necessary unless start-up indicates a motor winding short.
- 9. Connect the following system inputs to their respective terminals on the I/O board:
 - a. Optional chilled liquid flow switch terminals 1 and 12 on TB3. Jumper JP10 must be configured in the 2-3 position on the main microboard.....
 - b. Optional condenser liquid flow switch terminals 1 and 11 on TB2. Jumper JP11 must be configured in the 2-3 position on the main microboard.
 - c. Remote mode ready to start contact terminals 26 and 27 on TB4
 - d. Remote start and stop contact terminals 1 and 7 on TB3
 - e. Verify that the jumper is installed between terminals 21 and 24 on TB6
 - f. Optional chilled liquid pump run contacts are installed on terminals 44 and 45 on TB4
 - g. Optional condenser pump run contacts are installed on terminals 150 and 151 on TB5

NOTE: For contact information and additional field wiring, see *Form 161.01-PW2*.

E. PURGE SETUP

- Remove fan cover on condensing unit
- Remove exhaust port cap prior to starting purge.....
- Purge exhaust pipe connected to refrigerant relief piping

F. Customer Representative:

Name: _____
 Title: _____
 Date: _____

Name: _____
 Title: _____
 Date: _____

G. CONTROL PANEL SYSTEM COMMISSIONING CHECKLIST

- 1. Verify that the control panel is configured according to the OptiView Control Center Manual (*Form 161.01-M1*).
- 2. Verify the sales order screen is populated
- 3. Verify motor end name on the nameplate matches sales order screen.
 Motor End Name: _____
- 4. Use the following checklist during commissioning to make sure that all setpoints have been programmed to the desired value

NOTE: Programming some of the Setpoints requires a *SERVICE* access level. To be sure you have access to all Setpoints, login at the *SERVICE* access level before you begin.

The Setpoints are grouped under the Display Screen in which they appear. The indented screens are subscreens of the numbered screens. They are accessed from the numbered screens. If any of the Setpoints have to be changed, use the standard programming procedures in the YZ Control Panel Operation Manual (*Form 161.01-OM1*). Thresholds, values, and calibrations of items marked with an asterisk "*" have been determined and entered/set at the YORK Factory at the time of manufacture.

H. EVAPORATOR SCREEN (HOME SCREEN)

(Press: Home > Evaporator)

Local Cooling setpoint	<input type="text"/>
Shutdown.....	<input type="text"/>
Restart	<input type="text"/>
Refrigerant.....	<input type="text"/>

I. CONDENSER REFRIGERANT LEVEL CONTROL SCREEN

(Press: Home > Condenser > Level Control)

Level Setpoint	<input type="text"/>
Startup Position	<input type="text"/>
Startup Delay	<input type="text"/>
Ramp Time	<input type="text"/>
Manual Increment	<input type="text"/>

J. PURGE SCREEN

(Press: Home > Condenser > Purge)

Purge Mode	<input type="text"/>
Manual Purge	<input type="text"/>
Purge Regen Control	<input type="text"/>

K. COMPRESSOR CAPACITY CONTROL

(Press: Home > Compressor > Capacity Control)

Override Control

Evaporator Pressure	<input type="text"/>
Override Threshold	<input type="text"/>
Condenser Pressure	<input type="text"/>
Override Threshold	<input type="text"/>
Motor Current % FLA	<input type="text"/>
Override Threshold	<input type="text"/>

L. MBC SCREEN

(Press: Home > Compressor > MBC)

MBC Heatsink Temperature	<input type="text"/>
J Bearing Temperature	<input type="text"/>
K Bearing Temperature	<input type="text"/>
H1 Bearing Temperature	<input type="text"/>
H2 Bearing Temperature	<input type="text"/>

M. SURGE PROTECTION SCREEN

(Press: Home > Compressor > Surge)

Shutdown	<input type="text"/>
Extended Run	<input type="text"/>
Count Window	<input type="text"/>
Count Limit	<input type="text"/>
Surge Sensitivity	<input type="text"/>

N. VARIABLE SPEED DRIVE (VSD) DETAILS SCREEN

(Press: Home > Motor)

Local motor current limit	<input type="text"/>
Pulldown demand limit	<input type="text"/>
Pulldown demand time	<input type="text"/>

O. MOTOR DETAILS SCREEN

(Press: Home > Motor > Motor Details)

Motor Windings Setup

Temperature A1	<input type="text"/>
Temperature B1	<input type="text"/>
Temperature C1	<input type="text"/>
Temperature A2	<input type="text"/>
Temperature B2	<input type="text"/>
Temperature C2	<input type="text"/>

Motor Cooling Control

Motor Housing Temperature	<input type="text"/>
Motor Housing Temperature Setpoint	<input type="text"/>

P. HYPERTERMINAL CONNECTIONS

- 1. Download setpoint data to laptop
- 2. Download history data
- 3. Download sales order data

NOMENCLATURE

SYSTEM NOMENCLATURE



MOTOR END NAMING

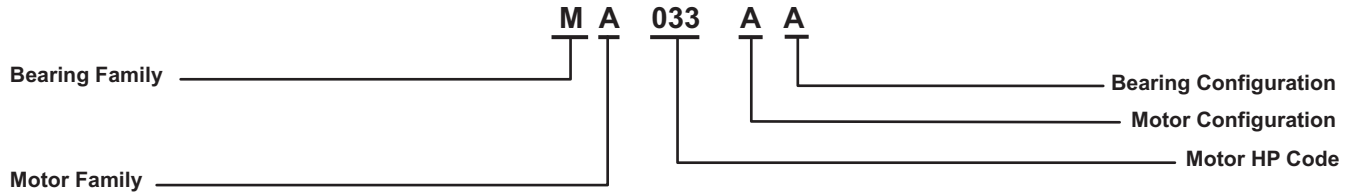

STAGE END NAMING

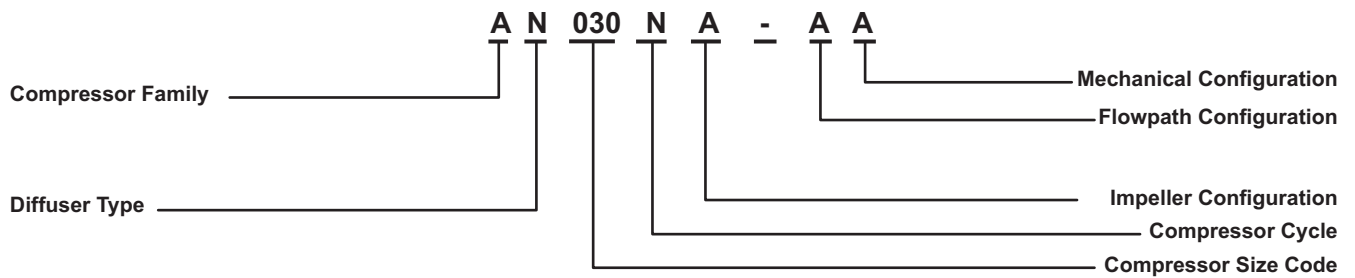

VARIABLE SPEED DRIVE NOMENCLATURE

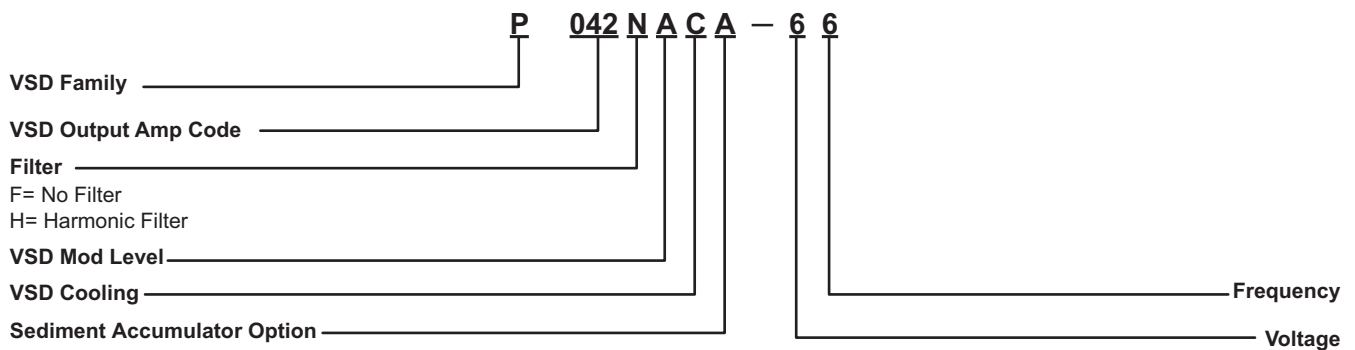

LD26924

NOMENCLATURE (CONT'D)

EVAPORATOR NAMING

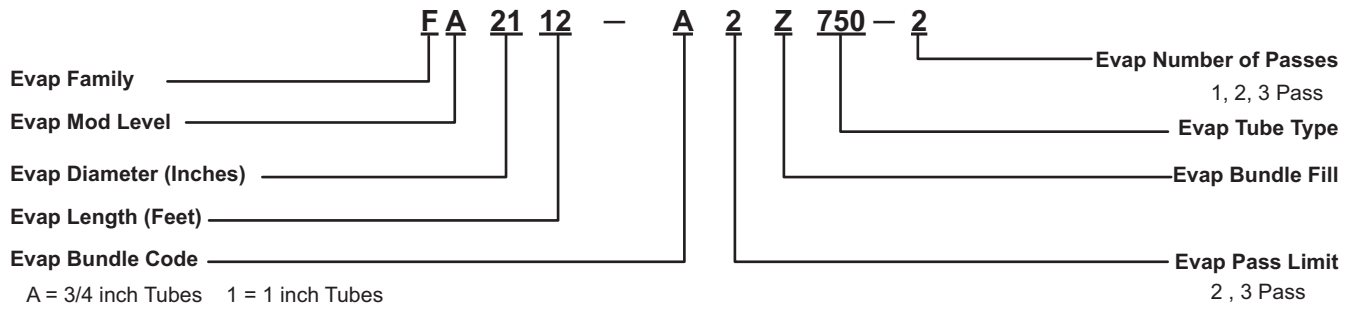

EVAPORATOR WATERBOX NAMING

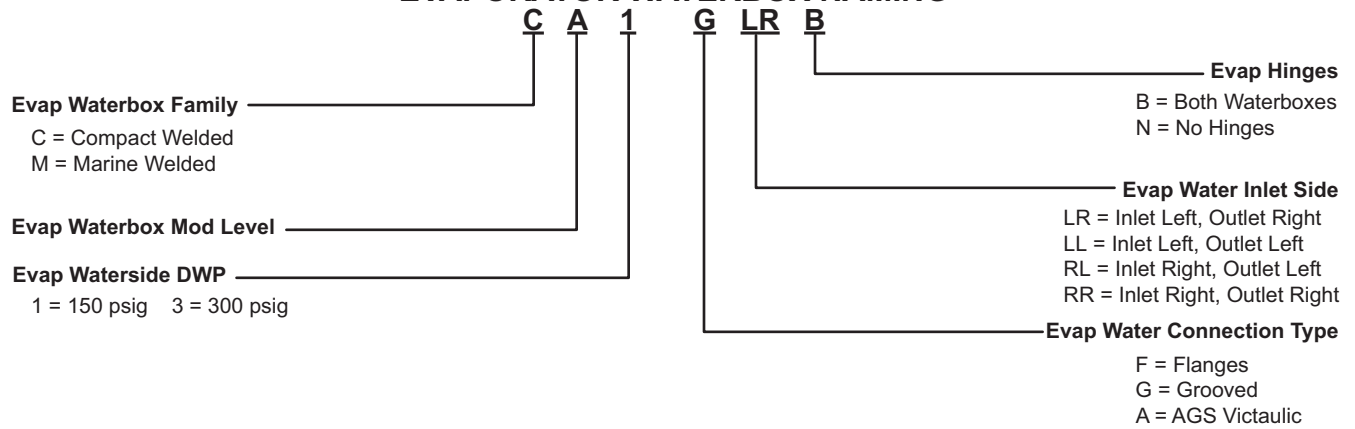

CONDENSER NAMING

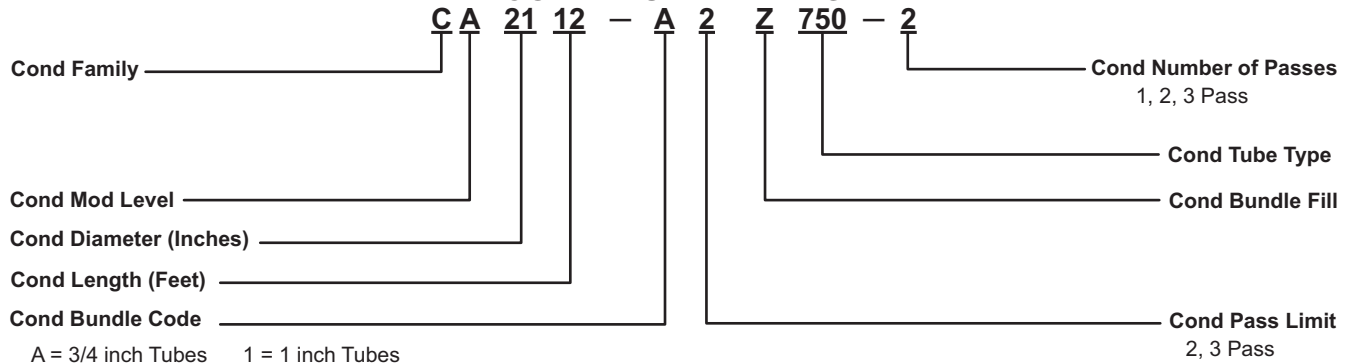

CONDENSER WATERBOX NAMING

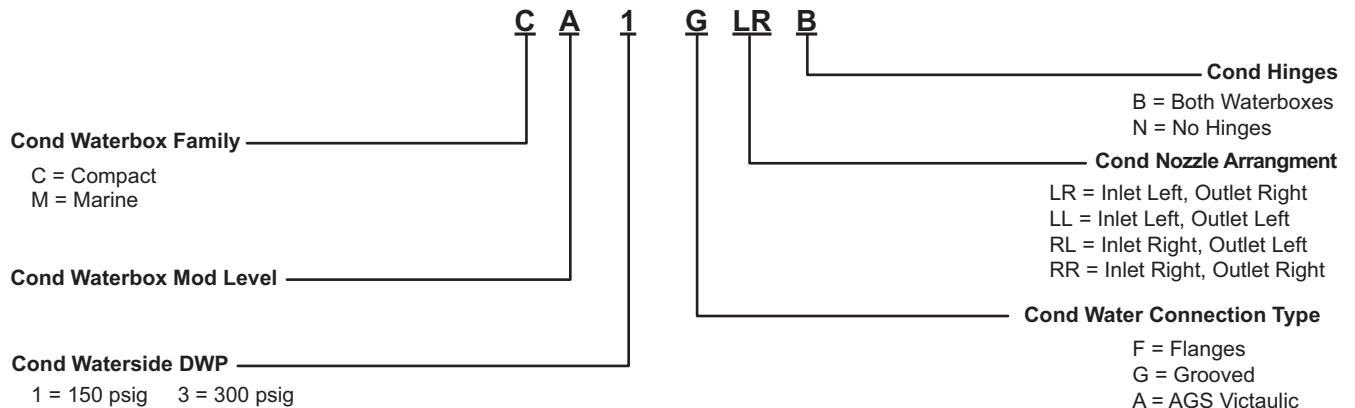

LD2692E



5000 Renaissance Drive, New Freedom, Pennsylvania USA 17349
Copyright © by Johnson Controls 2018
Form 161.01-CL2 (718)
Issue Date: July 18, 2018
Supersedes: 161.01-CL2 (118)

800-861-1001
www.johnsoncontrols.com

Subject to change without notice. Printed in USA
ALL RIGHTS RESERVED