



# YZ CENTRIFUGAL CHILLER

**INSTALLATION CHECKLIST**

Supersedes: 161.01-CL1 (618)

Form 161.01-CL1 (718)

035-27134-100

## INSTALLATION CHECKLIST AND REQUEST FOR AUTHORIZED STARTUP ENGINEER

CUSTOMER: \_\_\_\_\_

ADDRESS \_\_\_\_\_

PHONE \_\_\_\_\_

JOB NAME: \_\_\_\_\_

LOCATION: \_\_\_\_\_

CUSTOMER ORDER NO: \_\_\_\_\_

JCI TEL NO: \_\_\_\_\_

JCI ORDER NO: \_\_\_\_\_ JCI CONTRACT NO: \_\_\_\_\_

### SYSTEM NOMENCLATURE

SYSTEM \_\_\_\_\_ MOTOR \_\_\_\_\_

STAGE \_\_\_\_\_ VSD \_\_\_\_\_

EVAPORATOR \_\_\_\_\_

EVAPORATOR WATERBOXES \_\_\_\_\_

CONDENSER \_\_\_\_\_

CONDENSER WATERBOXES \_\_\_\_\_

UNIT SERIAL NO: \_\_\_\_\_

The work (as checked below) is in process and will be completed by: \_\_\_\_\_ / \_\_\_\_\_ / \_\_\_\_\_  
Month Day Year

The following work must be completed in accordance with installation instructions:





## CONTRACTOR'S RESPONSIBILITIES AND INSTRUCTIONS TO USE FORM

This installation checklist provides a quick way to check if all necessary installation work was completed in accordance with all applicable installation instructions in Form 161.01-N1, and when completed, acts as a request for Johnson Controls to furnish start-up supervision.

Complete this form as follows:

1. Fill out the top of page 1.
2. Check off each item as required. Cross out (x) items that do not apply.
3. Enter names, initials, and date of the operating personnel who completed the checklist.
4. **Bottom of Form:** Enter the date that the Johnson Controls start-up technician should be at the job site and the name(s) of the supervisor(s) to be contacted.
5. Retain one copy in files and send one copy to customer.

With reference to the terms of the above contract, we are requesting the presence of your JCI Authorized Representative at the job site on \_\_\_\_\_ / \_\_\_\_\_ / \_\_\_\_\_ to start the system and instruct operating personnel.  
Month Day Year

Have the JCI representative contact: \_\_\_\_\_  
Name/Phone

**TERMS:** We understand that the services of the Johnson Controls Authorized Representative will be furnished in accordance with the contract for a period of time of not more than \_\_\_\_\_ consecutive normal working hours, and we agree that a charge of \_\_\_\_\_ per diem plus travel expenses will be made to Johnson Controls if services are required for longer than \_\_\_\_\_ consecutive normal hours or if repeated calls are required, through no fault of Johnson Controls.

**Customer/Contractor Signature:** \_\_\_\_\_

**Customer/Contractor Name:** \_\_\_\_\_  
**(Print)**

**Title:** \_\_\_\_\_

**Form Completed by:** \_\_\_\_\_

**JCI Representative Signature:** \_\_\_\_\_

**JCI Representative Name: (Print)** \_\_\_\_\_

**Title:** \_\_\_\_\_

**Form Completed by:** \_\_\_\_\_



## ADDITIONAL INFORMATION

### SYSTEM NOMENCLATURE

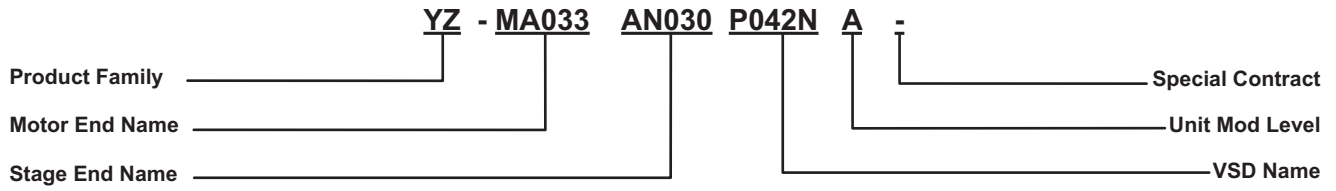

### MOTOR END NAMING

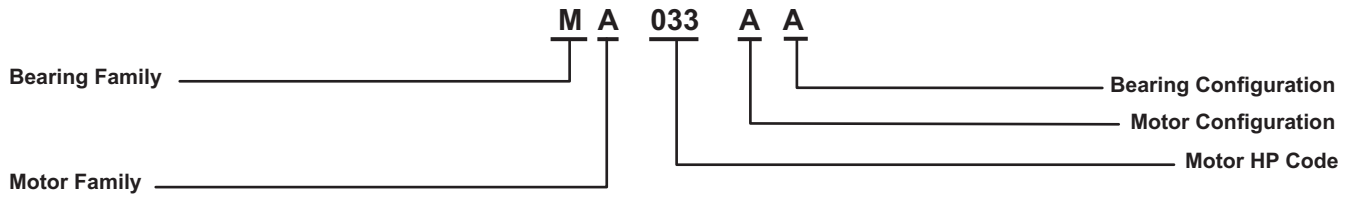

### STAGE END NAMING

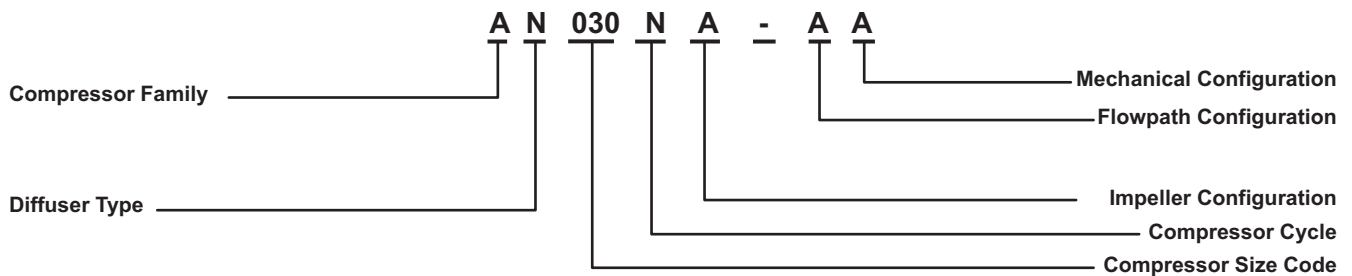

### VARIABLE SPEED DRIVE NOMENCLATURE

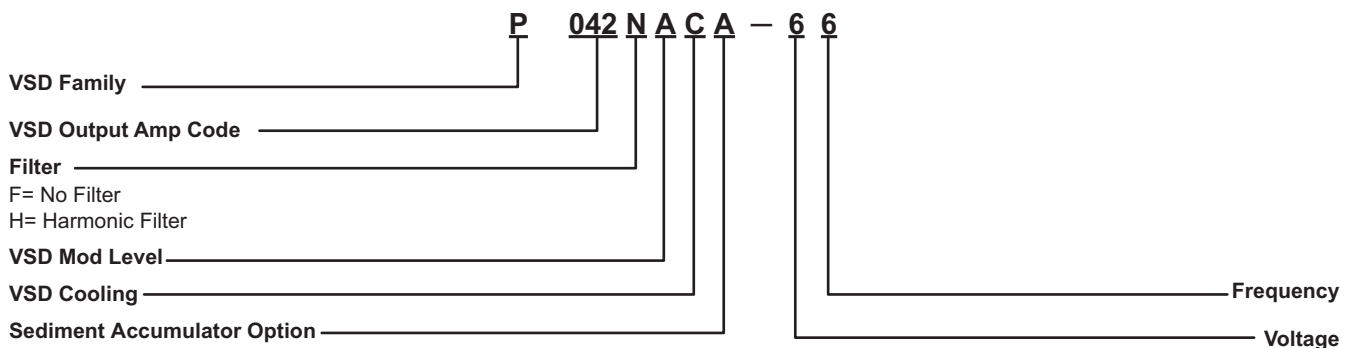

LD26924

## ADDITIONAL INFORMATION, CONT'D

### EVAPORATOR NAMING

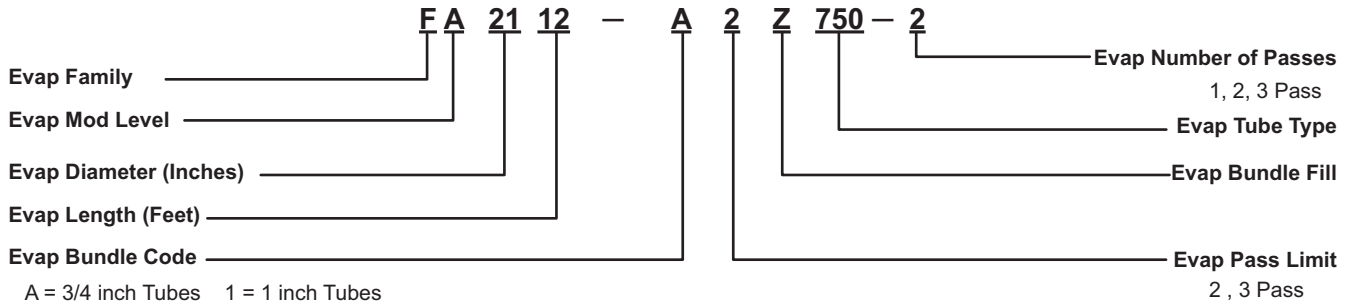

### EVAPORATOR WATERBOX NAMING

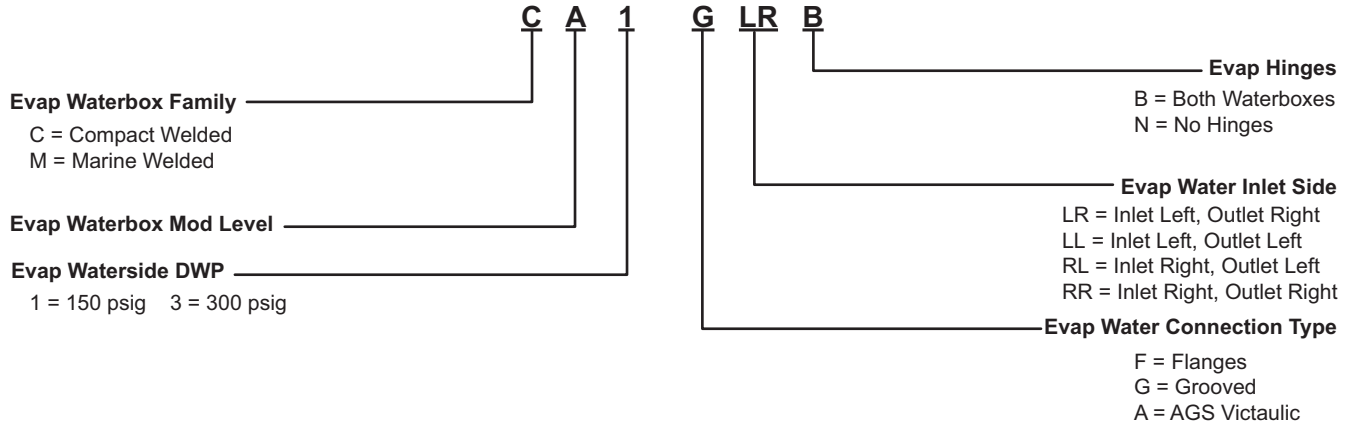

### CONDENSER NAMING

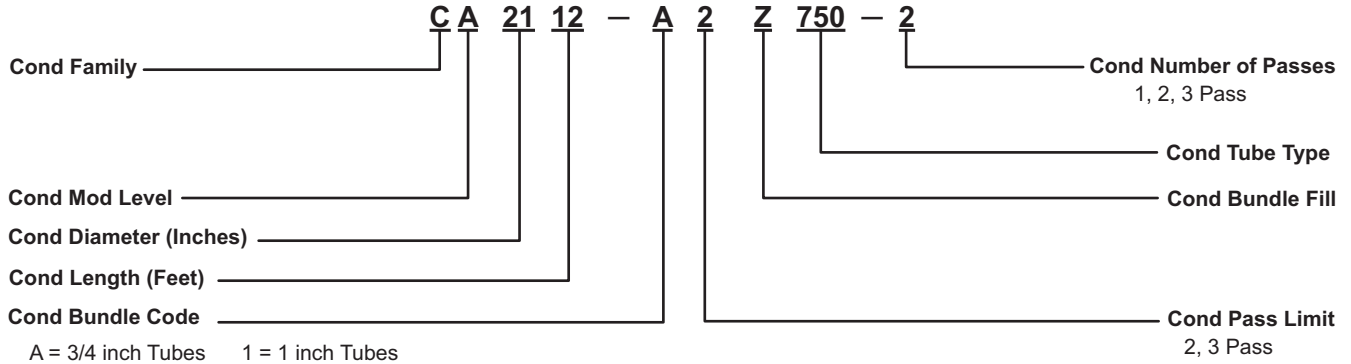

### CONDENSER WATERBOX NAMING

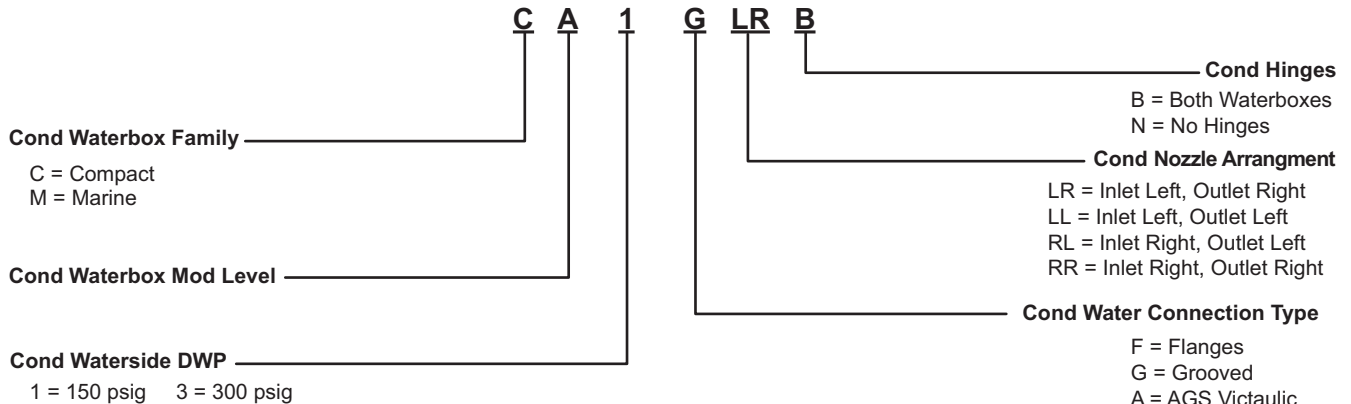

LD26925