

Model YVFA Air-Cooled Liquid Chillers With VSD Screw Compressor And Integrated Free Cooling Style A

215-380 Tons
765-1340 kW
2 Compressor
50 and 60 Hz
HFC-134a

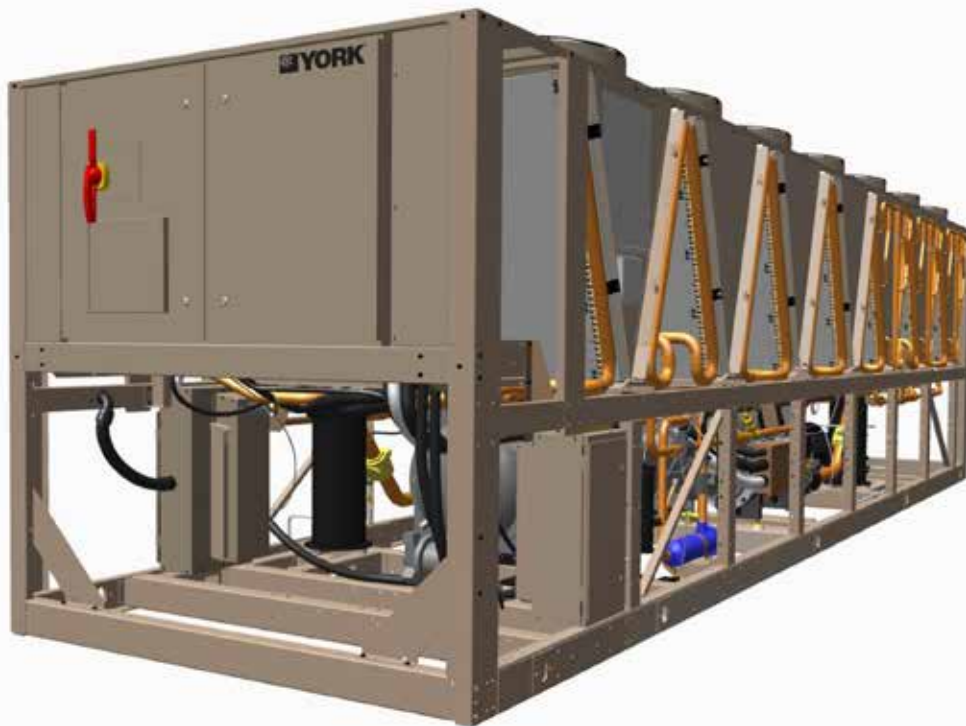

Nomenclature

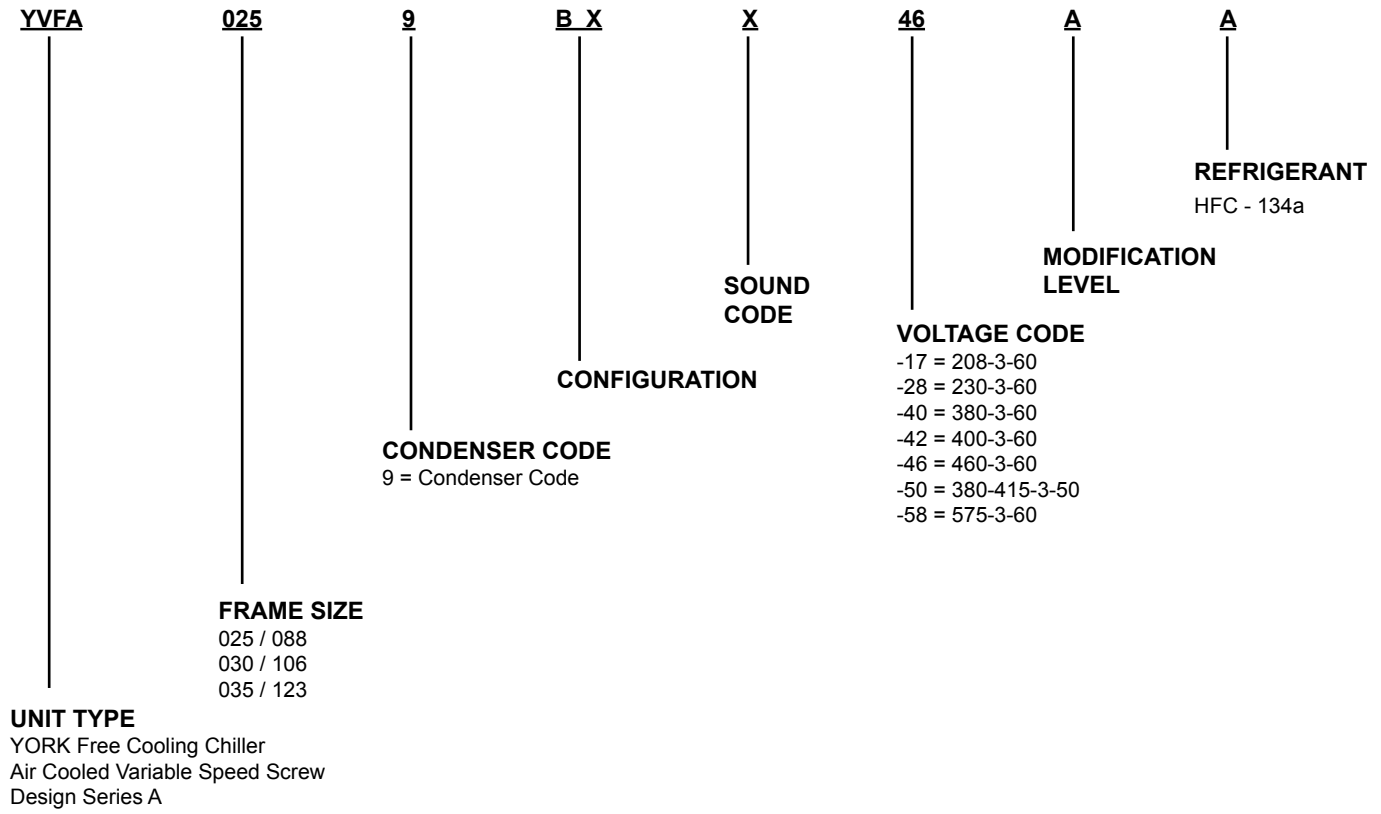

Approvals

- ASME Boiler and Pressure Vessel Code – Section VIII Division 1.
- AHRI Standard 550/590 and 551/591.
- UL 1995 – Heating and Cooling Equipment
- ASHRAE 15 – Safety Code for Mechanical Refrigeration
- ASHRAE Guideline 3 – Reducing Emission of Halogenated Refrigerants in Refrigeration and Air-Conditioning Equipment and Systems
- N.E.C. – National Electrical Code
- OSHA – Occupational Safety and Health Act

Due to the configurability of this product, images contained in this document are illustrations and may not represent a specific unit.

Table of Contents

INTRODUCTION	5
UNIT OVERVIEW	7
YVFA CONTROL CENTER	11
ACCESSORIES AND OPTIONS	13
REFRIGERANT FLOW DIAGRAM	18
APPLICATION DATA	19
PHYSICAL DATA	25
Microchannel Coil - English (SI)	25
YVFA0259/YVFA0889 Unit Dimensions	26
YVFA0309/YVFA1069 Unit Dimensions	28
YVFA0359/YVFA1239 Unit Dimensions	30
Elastomeric Isolators	32
One Inch Deflection Spring Isolator (CPX-X-)	33
ELECTRICAL DATA	34
WIRING	35
Single Point Wiring	35
Control Wiring.....	36
Customer Control Wiring	38
GUIDE SPECIFICATIONS	39

THIS PAGE INTENTIONALLY LEFT BLANK.

Introduction

Allows YVFA compressors to operate efficiently across all cooling load and ambient temperature conditions

The YORK YVFA Free Cooling Air-Cooled Screw Chiller delivers the lowest possible operating cost by combining superior engineering and technology in a packaged design that's simple to own and operate. Advanced technologies including a variable speed drive compressor, energy optimized hybrid cooling mode and air to liquid free cooling coils designed by our heat transfer experts are intelligently controlled to maximize efficiency year-round, automatically. YORK, the leader in air cooled chillers with Variable Speed Drive compressors, continues a legacy of innovation with the first integrated Variable Speed Drive screw chiller with free cooling.

EFFICIENCY

Industry-Leading Variable-Speed Drive (VSD) Technology - Allows YVFA compressors to operate efficiently across all cooling load and ambient temperature conditions.

High-Efficiency, Air-To-Liquid “Free Cooling” Coils - Reduce or eliminate the need for mechanical cooling when ambient conditions allow. Plus, the free-cooling coils are integrated within a traditional chiller footprint to conserve space.

Intelligent Controls - optimize operation year-round, constantly evaluating conditions and controlling bypass valves to reduce pump energy when free cooling is not beneficial.

Performance is assured by AHRI Certification - the first time certification has been given to an air-cooled screw chiller with free cooling.*

Annual Energy Cost (AEC) Report verifies payback in as little as three years - To confirm that your chiller selection delivers the smallest possible energy footprint, we use AEC modeling to produce a customized report factoring in all key variables — geographic location, building type, operating hours, utility costs and local weather data. In most locations, a facility operating 24/7 with a constant cooling load can achieve an operating cost payback within three or four years. Our AHRI-certified testing laboratory can demonstrate performance under your application's conditions.

Hybrid mode uses advanced technologies - For unsurpassed efficiency at part-load conditions. The VSD screw compressor can turn down capacity to reduce power draw below the power required by fan motors to move air. At part-load conditions, the chiller uses optimized “Hybrid Mode” with free-cooling coils to provide pre-cooling, with the compressor efficiently delivering the final cooling to meet the setpoint.

Optimized liquid circuit prevents wasted pump energy - Designed with low liquid pressure drop in mind, the YVFA chiller employs oversized pipe and fittings, a highly optimized free cooling coil, and an automatic bypass to prevent pumping through the coils when not beneficial.

Introduction (Cont'd)

SIMPLICITY

Packaged controls include single-point convenience

YVFA controls simplify operation with single-point control that easily accommodates process or building changes. When a new setpoint is required, adjustment can be made at the chiller control panel or through a Building Automation System (BAS). The free-cooling function automatically adjusts to deliver the best performance at the required conditions.

Open-loop unit design maximizes free cooling

The YVFA open-loop unit design permits building glycol to flow through the free-cooling coils directly, providing the best performance at the lowest first cost.

Reliability

Three generations of Johnson Controls expertise in variable-speed driven, air-cooled chillers ensure superior efficiency and reliability in the YVFA design. Variable-frequency inverter technology enables a zero-inrush soft start and a high displacement power factor across the entire operating range. For critical process and data center applications, the Quick Start option achieves full load after a power-loss restart in four minutes or less. On the jobsite, all YVFA models fit within a standard 40-foot shipping container for lowest possible rigging and shipping costs.

Unit Overview

SEMI-HERMETIC YORK TWIN SCREW COMPRESSORS

The direct-drive, semi-hermetic rotary twin-screw compressors incorporate advanced technology in a rugged design. The continuous function, microprocessor controlled VSD provides smooth capacity control from 100% down to 10% of chiller capacity. State-of-the-art technology, obtained from decades of screw compressor design, ensures optimal efficiencies at all chiller load points. With no unloading steps or slide valves in the compressors, the YVFA variable speed driven compressors have 50% fewer moving parts than fixed speed compressors with slide valves. The YVFA compressor is one of the most efficient and reliable screw compressors in the industry.

FREE COOLING ECONOMIZER

YVFA is the first Variable Speed Drive Screw chiller to include integrated free cooling economizer coils. The free cooling coils reject heat directly to the atmosphere when ambient temperature permits, reducing mechanical cooling requirement and saving energy. The free cooling economizer coils are round tube, plate fin design, delivering a low liquid-side pressure drop to reduce pump energy and providing a robust design that can accommodate small particle debris from the building liquid loop without clogging. Coils are two-row depth and circuited to make draining for service easy. The coils are factory piped to the evaporator, providing simple single-point inlet and outlet connections to the unit. A pair of factory mounted, unit powered and controlled butterfly valves divert liquid to the economizer when ambient is suitable for free cooling. The coils are bypassed during high ambient to avoid unnecessary pressure drop and reduce pump energy.

EVAPORATOR

The evaporator is a shell and tube, hybrid falling film type heat exchanger. It contains a balance of flooded and falling film technology to optimize efficiency, minimize refrigerant charge, and maintain reliable control. A specially designed distribution system provides uniform refrigerant flow for optimum performance.

CONDENSER

YVFA uses microchannel condenser heat exchangers, which provide excellent heat transfer and airflow for the best efficiency while operating mechanical cooling. Charge quantity is reduced up to 30% compared to traditional round tube condenser coils and the heat exchangers are single-row depth for simple rinse cleaning. Microchannel coils are made of a single material to avoid galvanic corrosion due to dissimilar metals. Tubes, fins and headers are brazed as one piece, minimizing leaks. The inherently rugged construction, which includes non-overhanging fins, eliminates the possibility of fin damage.

The condenser fans are composed of corrosion resistant aluminum hub and glass-fiber reinforced polypropylene composite blades molded into a low-noise airfoil section. All blades are statically and dynamically balanced for vibration-free operation. Fan motors are Totally Enclosed Air-Over (TEAO), inverter duty, IP54 rated, and current protected. Variable speed drives, standard, reduce energy use and sound at part load while maximizing condenser and economizer heat transfer performance. The motors feature double-sealed and permanently lubricated ball bearings, reducing maintenance costs over the life of the unit.

Unit Overview (Cont'd)

REFRIGERANT CIRCUIT

The YVFA has one independent refrigerant circuit per compressor. Each circuit uses copper refrigerant pipe formed on computer-controlled bending machines. By using computer-aided technology, over 60% of system piping brazed joints have been eliminated (as compared to designs that use fittings), resulting in a highly reliable and leak-resistant system.

COMPLETE FACTORY PACKAGE

Each unit is shipped as a complete factory package, completely assembled with all interconnecting refrigerant piping and internal wiring and ready for field installation. Prior to shipment, each individual chiller undergoes an extensive testing procedure, ensuring workmanship is the highest quality and that the initial start-up is trouble-free.

Before leaving the factory, each refrigerant circuit is factory pressure tested, evacuated, and then fully charged with R134a refrigerant and oil. An operational test is performed with water flowing through the evaporator to ensure each circuit functions correctly.

ELECTRICAL

All controls and motor starting equipment necessary for unit operation are factory wired and function tested. There are no surprises when you go to start-up; you can have confidence that the unit will start up right the first time and every time.

The chillers are available with a single point power connection and are supplied with a factory mounted and wired control transformer that powers all unit controls from the main unit power supply. The transformer utilizes scheduled line voltage on the primary side and provides 115 V/1Ø on secondary. The standard unit is equipped with terminal block electrical connections. All exposed power wiring is routed through liquid-tight, UV-stabilized, non-metallic conduit. Selection of frame 36 and larger are standard dual point, with single point option.

VSD Power/Control Panel includes main power connection(s), VSD and fan motor contactors, current overloads, and factory wiring. All display and control features can be accessed through the keypad and control display access door, eliminating the need to open the main cabinet doors.

BUILDING AUTOMATION SYSTEM CAPABILITIES

The E-Link Gateway provides an economical and versatile connection between Johnson Controls equipment and open/standard protocols. It efficiently manages the communication protocols currently used by Johnson Controls equipment, exposing the data in a consistent, organized, and defined fashion. A simple switch selection allows configuration of the required equipment profile and output protocol, which reduces equipment connectivity startup time.

Johnson Controls systems or another vendor's systems can incorporate these setpoints and data outputs to give the customer a complete understanding of how the system is running through a Building Automation System.

During extreme or unusual conditions (i.e. blocked condenser coils, ambient above scheduled maximum, etc.) the chiller control system will avoid shutdown by varying capacity. By monitoring motor current and suction and discharge pressures, the chiller can maintain maximum available cooling output without shutting down.

Unit Overview (Cont'd)

Unit Safeties are provided for the chiller to perform auto-reset shut down for the following conditions:

- Ambient temperature above or below allowable range
- Out of range leaving chilled liquid temperature
- Under voltage
- Flow switch operation

AHRI CERTIFICATION PROGRAM

YORK YVFA chillers have been tested and certified by Air-Conditioning, Heating and Refrigeration Institute (AHRI) in accordance with the latest edition of AHRI Standard 550/590 (I-P). Under this Certification Program, chillers are regularly tested in strict compliance with this Standard. This provides an independent, third-party verification of chiller performance. Refer to the AHRI site at www.ahrinet.org/ for complete Program Scope, Inclusions, and Exclusions as some options listed herein fall outside the scope of the AHRI certification program. For verification of certification, go to the AHRI Directory at www.ahridirectory.org.



Rated in accordance with the latest issuance of AHRI Standard 550/590 and 551/591.

YVFA units conform with the following European Directives:

- Machinery Directive (2006/42/EC)
- EMC Directive (2004/108/EC)
- Pressure Equipment Directive (97/23/CEE)
- Safety Code for Mechanical Refrigeration EN 378- 2 (2008)/A2(2012) [Safety accessories according to essential requirements in PED paragraph 2.11.1 have been calculated according to EN13136:2001/A1:2005 and are not following the requirements in EN378-2:2008 paragraph 6.2.6.2, unless dual relief valves are fitted]
- Safety of machinery - Electrical Equipment of Machine (EN 60204-1)
- Generic emissions and immunity standards for industrial environment EN61000-6-4:2007 & 61000- 6-2:2005
- ISO 9614 – Determination of sound power levels of noise sources using sound intensity
- ECO Design Directive (2009/125/EC) Fan/motor Efficiency EN ISO 5801
- Manufactured in an EN ISO 9001 accredited organization
- Conform to CE Testing Services for construction of chillers and provide CE Listed Mark

Unit Overview (Cont'd)

OFF-DESIGN PERFORMANCE

Since the vast majority of operating hours are spent at off-design conditions, a chiller should be chosen not only to meet the full load design, but also for its ability to perform efficiently at lower loads. It is not uncommon for chillers with the same full load efficiency to have an operating cost difference of over 10% due to differences in off-design (part load) efficiencies.

Annual Energy Cost can be calculated quickly and accurately by computer using simple inputs of geographic location, building load profile and operating hours. For a facility with higher operating hours and load profile than comfort cooling, Annual Energy Cost must be considered when comparing overall performance of mechanical and economizer operation.

In addition to Annual Energy Cost, YVFA ratings also include Integrated Part Load Value (IPLV) and Non-Standard Part Load Value (NPLV), standardized within the AHRI Certification Program. These values do not include economizer operation, as this is outside the scope of the AHRI program.

YVFA Control Center

UNIT CONTROL CENTER

The unit control center provides automatic control of chiller operation including compressor start/stop and load/unload anti-recycle timers, condenser fans, chilled liquid pump, evaporator heater, unit alarm contacts and run signal contacts. The microcomputer control center comes online as soon as the main power switch on the unit is switched on; immediately, the microcomputer control center will begin to continuously monitor all variables.

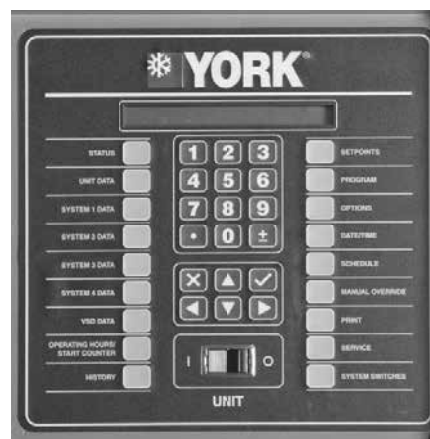

LD19911

FIGURE 1 - YVFA CONTROL CENTER KEYPAD AND DISPLAY

The microprocessor controls the unit's capacity by matching the actual leaving chilled liquid temperature (LCHLT) to the user-defined setpoint. Factors that may cause the system's actual LCHLT to fluctuate are changes in ambient temperature, load, and chilled liquid loop flow rate and volume. The controls system reacts to such changes by adjusting the number of compressors that are on and the loading of each compressor in order to keep the LCHLT at the setpoint.

The controls system logic monitors the rate at which the LCWT is approaching the setpoint to ramp up or down compressor capacity as required. The variable frequency drive allows the compressor capacity to match the load.

Display Data

- Leaving Chilled Liquid Temperature
- Returning Liquid Temperature
- Ambient Temperature
- Lead System
- Compressor Capacity (% of Full Load Amps)
- VSD Output Frequency/Compressor Speed

YVFA Control Center (Cont'd)

- Compressor Run Hours
- Compressor Number of Starts
- Oil Pressure and Temperature (per Compressor)
- Chilled Liquid Pump Status
- Evaporator Heater Status
- History Data for Last 20 Normal Shutdowns
- History Data for Last Ten Shutdown Faults

Programmable Setpoints

- Chiller On/Off
- Chilled Liquid (Water or Glycol)
- Local or Remote Control
- Units of Measure (Imperial or SI)
- System Lead/Lag
- Remote Temperature Reset
- Remote Current Limit
- Leaving Chilled Liquid Temperature Setpoint and Range

Accessories and Options

All options factory mounted unless otherwise noted.

SOUND ATTENUATION

Low Noise Kits – The standard chiller configuration is equipped with variable speed, high airflow fans. There are several sound attenuation options available to further reduce sound at its source thereby meeting local sound level regulations.

CONDENSER COIL PROTECTION

The alloys used in the YVFA microchannel condenser and economizer coils have been carefully selected and tested for high corrosion resistance. However, all metals can corrode in harsh conditions. Consider protecting coils from corrosive environments such as coastal, marine, urban, and industrial.

Post-Coated Epoxy Dipped Condenser and Economizer – Microchannel condenser and round tube economizer coils coated with an electro-deposited and baked flexible epoxy coating that is finished with a polyurethane UV resistant top-coat. This is suitable for highly corrosive applications.

PROTECTIVE CHILLER PANELS

Wire Panels – Heavy-gauge, welded-wire-mesh guards mounted on the exterior of the full unit. The guards are coated to prevent corrosion with a UV stabilized material. The wire panels protect condenser coil faces and prevent unauthorized access to refrigerant components (compressors, pipes, evaporator, etc.), yet provide free air flow. This can cut installation cost by eliminating the need for separate, expensive fencing. See Figure 2.

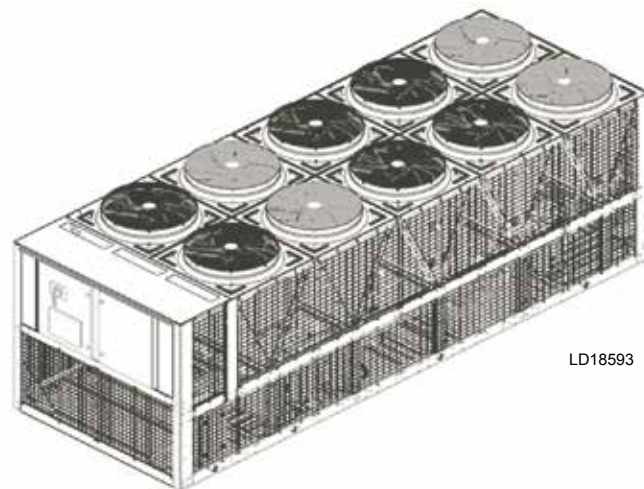

LD18593

FIGURE 2 - FULL UNIT WIRE PANELS

Accessories and Options (Cont'd)

Louvered Panels – Louvered panels, painted the same color as the unit, enclose the unit to visually screen and protect the coils as well as prevent unauthorized access to internal components. Also available as a condenser-only option. See Figure 3.

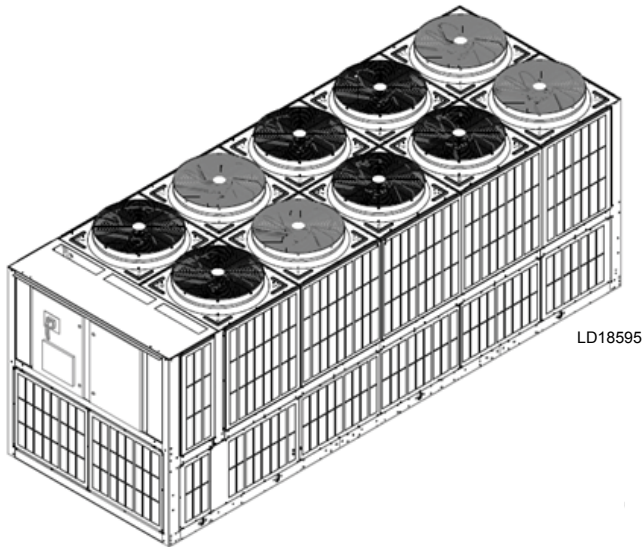

FIGURE 3 - FULL UNIT LOUVERED PANELS

Louvered/Wire Panels Combination – Louvered panels, painted the same color as the unit, are mounted on external condenser coil faces. Heavy gauge, welded wire-mesh panels, coated to resist corrosion with a UV stabilized material, are mounted around base of machine to restrict unauthorized access. See Figure 4.

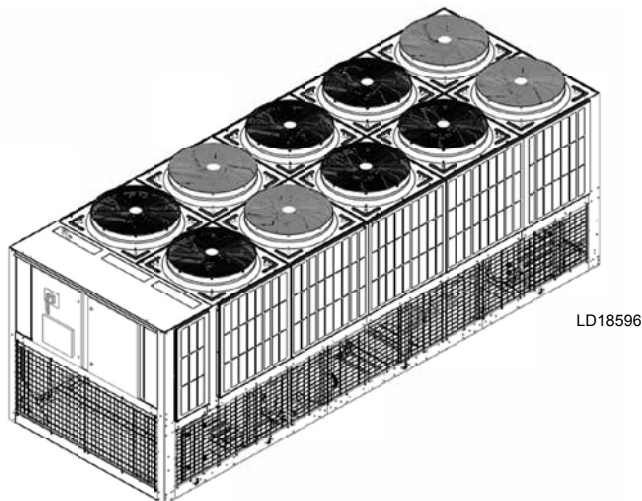

FIGURE 4 - LOUVERED/WIRE PANELS COMBINATION

Accessories and Options (Cont'd)

V-Guard Panels – Solid panels, painted the same color as the unit, are installed along the sides of the units to cover exposed piping within the condenser section without impacting airflow. These guard panels can be combined with End Hail Guard option for additional protection from flying debris. See Figure 5.

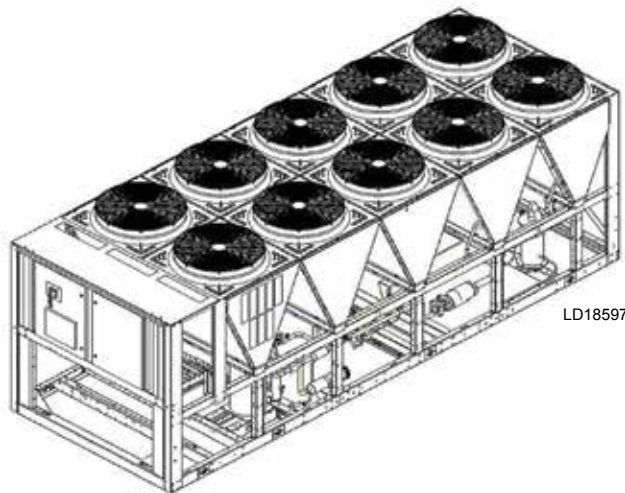

FIGURE 5 - V-GUARD OPTION

EVAPORATOR OPTIONS

Flange Kit – Provides contractor with the couplings best suited to connect the chiller to the chilled liquid piping. All flanges are ANSI 150 psig (10.3 barg). Field mounted. Options include:

- **ANSI/AWWA C-606 Flanges** – Two flanges, for applications where field piping has existing flanges
- **Weld Flanges** – Four flanges, two ANSI/AWWA C-606 connections to chiller and two weld flanges for field piping

Water Box Heater – The standard unit comes with freeze protection on the evaporator down to 0°F (-17.8°C) Unless the appropriate concentration of glycol is used, optional water box heaters are required for storage below 0°F (-17.8°C). See "*Application Data*" on page 19 for additional information on freeze protection. Separate 120 V/60 Hz or 230 V/50 Hz single phase power supply required.

CONTROLS OPTIONS

Building Automation System Interface (Temperature) – Factory installed option to accept a 4 to 20 mA or a 0 to 10 VDC input to allow remote reset of the Leaving Chilled Liquid Temperature Setpoint. The setpoint can be positively offset upwards up to 40°F (22.2°C). This option is useful for process applications or for periods where higher chilled liquid temperatures are adequate for low loads. Available alone or in combination with BAS Load Limit.

Accessories and Options (Cont'd)

Building Automation System Interface (Load Limit) – Factory installed option to accept a 4 to 20 mA or a 0 to 10 VDC input to allow remote reset of the Load Limit Setpoint. The setpoint can limit system demand from 30-100%. Available alone or in combination with BAS Temperature Reset.

E-Link – The E-Link gateway provides full communication to Building Automation Systems, including BACnet (MS/TP), Modbus, LON and N2.

GENERAL OPTIONS

Thermal Dispersion Flow Switch – Solid state thermal dispersion flow switch with no moving parts for high reliability and long service life. Stainless steel probe and IP 67 housing with LED status indicator of flow and output condition. Includes 10m IP67 cable required for field installation near chiller and bronzed steel welding adapter to ensure correct insertion depth. **Field Mounted.**

Differential Pressure Switch – This 3-45 PSIG (0.2-3 BarG) range switch, with 1/4 inch NPTE pressure connections, is an alternative to the paddle-type flow switch. **Field mounted.**

Service Isolation Valve – Service suction isolation valve added to the unit for each refrigerant circuit. Valve is available in both manual and chiller actuated configurations. Actuated valve is recommended for operation below freezing ambients with water in evaporator (refer to "Operation in Sub-freezing Conditions" on page 21).

Chicago Code Relief Valve – Special relief valves per Chicago code.

Dual Pressure Relief Valve – Two safety relief valves are mounted in parallel; one is always operational to assist in valve replacement during maintenance.

Pressure Vessel Options – The evaporator can be provided with ASME, PED or GB pressure vessel codes certification.

Circuit Breaker – Unit-mounted circuit breaker(s) with external lockable handle(s) will be supplied to isolate the power voltage for servicing. The circuit breaker(s) is (are) sized to provide motor branch circuit protection, short circuit protection and ground fault protection for the motor branch-circuit conductors, the motor control apparatus, and the motors.

Quick Start – Special software allows the chiller to achieve full capacity within four minutes of power being restored. Designed for process and data center applications where recovering liquid temperature control rapidly after power loss is especially critical. Not recommended for comfort cooling applications as chiller may temporarily reach liquid temperature below set point while ramping quickly to achieve full load.

Non-Fused Disconnect Switch – Unit-mounted disconnect switch(es) with external lockable handle can be supplied to isolate the unit power voltage for servicing. Separate external fusing must be supplied by the power wiring, which must comply with local codes.

Accessories and Options (Cont'd)

Special Requirement Documents – There are two options to select from:

- Special Requirement Document Package (SRDP) includes Pressure Vessel Report, Unit Run Test Report, Production System Check Sheet, and Final Unit Inspection Check Sheet.
- Materials Package includes steel mill material reports for vessels in addition to the SRDP.

VIBRATION ISOLATION

Elastomeric Isolation – This option is recommended for normal installations. It provides very good performance in most applications for the least cost. **Field mounted.**

1 Inch Spring Isolators – Spring and cage type isolators for mounting under the unit base rails are available to support unit. They are level adjustable. 1” nominal deflection may vary slightly by application. **Field mounted.**

Refrigerant Flow Diagram

Low pressure refrigerant (liquid and gas) enters the evaporator and is sprayed across the top of the tube bundle from spray nozzles. The liquid refrigerant from the nozzles gravity drains down across the tube bundle and is evaporated and superheated by the heat energy absorbed from the chilled liquid passing through the tubes.

The low pressure refrigerant vapor leaves the top of the evaporator and enters the compressor where the refrigerant vapor is compressed and the pressure and superheat are increased. The high pressure superheated gas enters the air cooled condenser where heat is rejected via the condenser coils and fans.

The fully condensed and sub-cooled liquid leaves the air cooled condenser, flows through the filter drier and enters the economizer tank. The flow of refrigerant into the economizer is controlled by the electronic expansion valve.

Additional cooling of the refrigerant liquid may take place in the economizer tank when the economizer valve is opened. After leaving the economizer tank, liquid refrigerant flows through an orifice where pressure reduction and further cooling take place. The low pressure refrigerant (liquid and gas) then enters the evaporator.

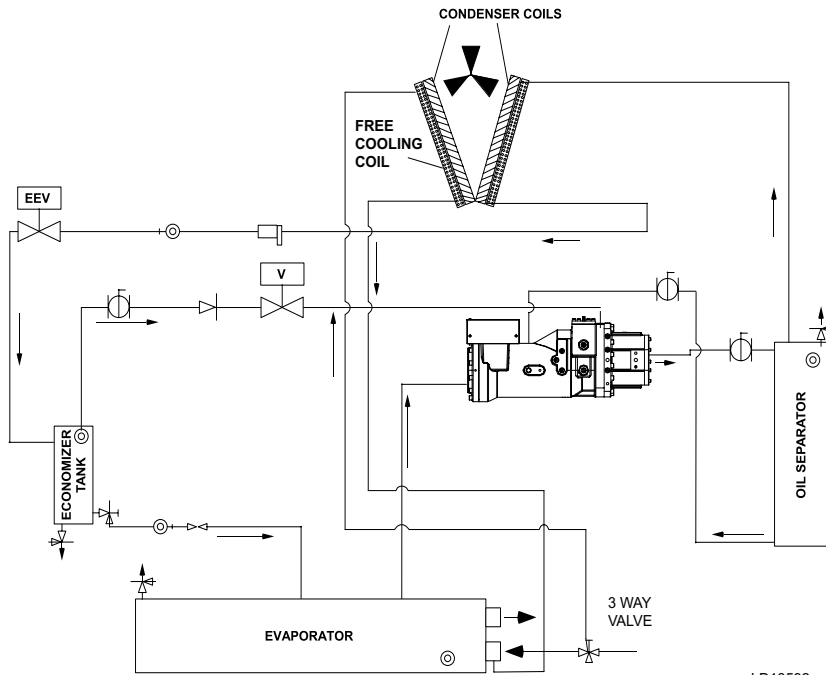

LD18592a

SYMBOL	YVFA SYSTEM COMPONENTS
	Electronic Expansion Valve
	Ball Valve
	Relief Valve
	Stop Valve Angle, Access
	Replacement Core Filter/Dryer
	Sight Glass
	Orifice
	Check Valve
	Valve

Application Data

UNIT SIZING

Avoid over-sizing a chiller. Properly sized chillers operate stably and provide the best life cycle cost. When designing phased projects, select multiple small chillers to match demand for each phase. Use multiple small chillers when the minimum cooling demand is less than 10% of the maximum cooling demand.

UNIT LOCATION

The YVFA chillers are designed for outdoor installation. To achieve optimum performance and trouble-free service provide adequate space around chillers (see Figure 7).

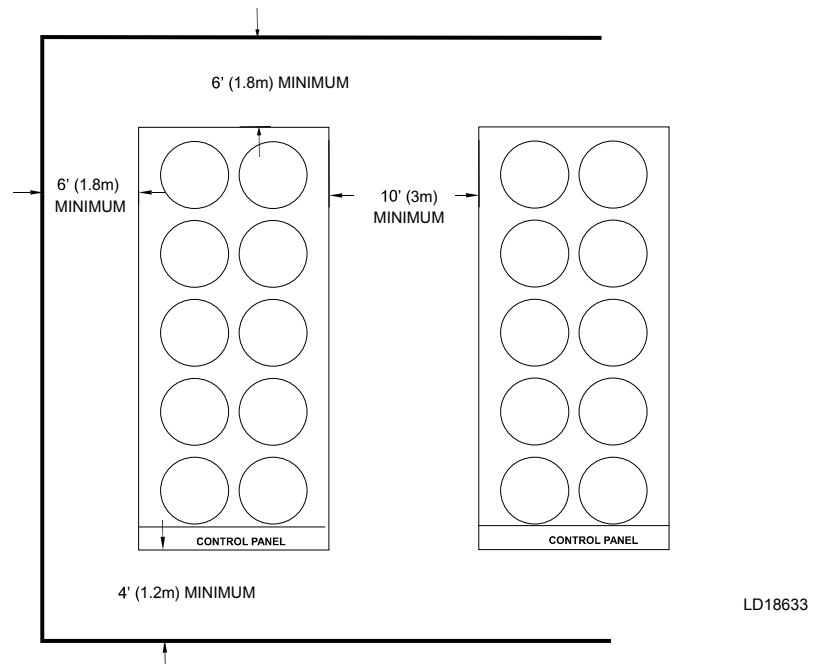

FIGURE 6 - ACCEPTABLE MINIMUM CLEARANCES AROUND/BETWEEN UNIT(S) FOR PROPER AIRFLOW

When selecting chiller installation sites, follow these requirements:

- A. Installation sites may be either on a roof or on ground level. (See *FOUNDATION on Page 20*)
- B. Provide space for air to flow into condensers per dimensions shown on the dimension drawing on "*Dimensions*" on page 18. Restricted airflow or hot air recirculation will diminish performance. Johnson Controls' unit controls will optimize the operation without nuisance high pressure safety cutouts; however, the system designer **MUST** consider potential performance degradation. Recommended clearances for all units are as follows:
 1. Access to the unit control center stipulates the unit is no higher than on spring isolators.

Application Data (Cont'd)

2. Recommended minimum clearances:
 - a. Side to wall – 6 feet (1.8m)
 - b. Rear to wall – 6 feet (1.8m)
 - c. Control panel end to wall – 4 feet (1.2m)
 - d. Top – no obstructions whatsoever
 - e. Distance between adjacent units – 10 feet (3m)
 3. No more than one wall around the chiller yard should be higher than the chiller(s).
- C. Avoid locations near windows or structures where normal operating sounds may be objectionable.
- D. The condenser fans are propeller-type and are not recommended for use with duct-work, filters, or other impediments to airflow in the condenser air stream.
- E. When obstructions to airflow exist, they must not add more than 0.1 inch external static pressure.
- F. Protection against corrosive environments is available by ordering the units with cured epoxy-coating on the condenser microchannel. Epoxy-coated coils should be used with any units being installed at the seashore, or where salt spray may hit the units, or where acid rain is prevalent.
- G. On installations where winter operation is intended and snow accumulations are expected, additional elevation must be provided to insure normal condenser air flow.
- H. Provide adequate space for tubes to be removed from evaporator. For clearances please contact your nearest Johnson Controls Sales Office.

FOUNDATION

Mount units on a flat and level foundation, ground or roof, capable of supporting the entire operating weight of the equipment. Please contact your nearest Johnson Controls Sales Office for shipping and operating weights.

Roof Locations – Provide structure to safely support the entire weight of the unit and service personnel. Do not damage the roof during installation. If the roof is of bonded construction, consult a building contractor or architect for special installation requirements. Use spring isolators to minimize vibration transmission into building structure. Provide additional structural support at the spring-isolator locations.

Ground Locations – Units must be installed on a substantial base that will not settle and cause strain on the refrigerant lines, resulting in possible leaks. A one-piece concrete slab, with footers extending below the frost line is recommended. The slab should not be tied to the main building foundation as operational noise will telegraph. Mounting holes (5/8 inch) are provided in the base rails for bolting the unit to its foundation. See *Isolator Locations on Page 19* for location of the mounting holes.

For ground installations, precautions should be taken to protect the unit from tampering by, or injury to, unauthorized persons. Fasteners on access panels will prevent casual tampering; however, further safety precautions such as unit enclosure options, a fenced-in enclosure, or locking devices on the panels may be advisable. Check local authorities for safety regulations.

Application Data (Cont'd)

Seismic Applications – Avoid installing chillers on springs or roofs where earthquakes are a risk. Springs and roofs amplify earthquake forces. Rigidly mounting chillers to ground level concrete pads is typically the best option for earthquake zones. Contact Johnson Controls equipment specialists for help with projects that have seismic requirements.

CHILLED LIQUID PIPING

Design the chilled liquid piping system so that the circulating pump discharges into the chiller inlet piping. The inlet and outlet liquid connections are given in "YVFA0259/YVFA0889 Unit Dimensions" on page 26. Hand stop valves are recommended in all lines to facilitate servicing. Provide drain connections at low points to permit complete drainage of the chiller and system piping.

The chiller must be protected by a strainer, preferably of 40 mesh, fitted as close as possible to the liquid inlet connection, and provided with a means of local isolation.

The chiller must not be exposed to flushing velocities or debris released during flushing. It is recommended that a suitably sized bypass and valve arrangement is installed to allow flushing of the piping system. The bypass can be used during maintenance to isolate the chiller without disrupting flow to other units.

Pressure-gauge connections are recommended for installation in the inlet and outlet liquid lines. Gauges are not provided with the unit and are to be furnished by others.

A flow switch is available as an accessory on all units. A flow switch must be installed in the leaving liquid piping of the chiller and must not be used to start and stop the unit.

Chilled liquid lines exposed to the weather should be wrapped with a supplemental heater cable and insulated, or glycol should be added to the chilled liquid to protect against freezing if low-ambient periods are expected.

OPERATION IN SUB-FREEZING CONDITIONS

The YVFA is designed for use with appropriate glycol concentration to prevent freezing in event of power loss. If operation below glycol concentration freeze point is required, the following freeze protections must be taken:

A. An automatic suction service valve electric actuator is installed. Chiller software will operate the actuator in order to protect against freezing due to evaporator refrigerant migration.

-or-

B. No suction service valve is installed but the liquid circuit valves are kept open, there is continuous power to the chiller and pump for pump control, and the pump will operate and circulate water through the evaporator whenever commanded by the chiller.

Warning: The above operation is only advised if uninterrupted power can be ensured. Unforeseen power interruptions can damage the evaporator in a very short time frame if the temperature falls below freezing.

If there is potential for power loss, Johnson Controls recommends the water in the chilled water circuit be replaced with an appropriate water-to-glycol concentration.

Application Data (Cont'd)

UNIT MAINTENANCE AND SHUTDOWN IN SUB-FREEZING CONDITIONS

If the YVFA is maintained or shut down and will be subjected to sub-freezing conditions, it is critical to protect against evaporator and waterbox freeze damage. Johnson Controls recommends the following options (in order of freeze protection level) be performed on each circuit.

A. **Glycol:** Replace water with an appropriate water to glycol concentration of antifreeze.

-or-

B. **Pump Control:** Keep power to the chiller in order to have control over chilled liquid pumps and heater operation and leave the water circuit valves open. This will enable liquid to circulate through the evaporator to avoid freezing.

Warning: Option A is the recommended processes for unit maintenance and shutdown. Unforeseen power interruptions can damage the chiller in a very short time frame if the temperature falls below freezing.

Note: Failure to follow Johnson Controls freeze protection recommendations can void the warranty.

ACTUATED SUCTION SERVICE VALVE CONTROL

The Actuated Suction Service Valve (ASSV) is controlled by ambient air temperature. When the air temperature drops below 40°F (4.4°C), the ASSV is closed. When the air temperature rises above 45°F (7.2°C), or any system is running, the ASSV is opened. Power must be available in order for the ASSV to operate. Both system ASSV digital outputs are turned on (VALVE CLOSED) and off (VALVE OPEN) together, not independently. Open and closed commands are controlled by the relay within the Suction Service Valve (SSV) junction box. Power is always applied to the Normally Closed contact during commanded open operation. To close the ASSV, power is applied to the relay coil within the SSV junction box to drive actuator closed through the Normally Open contact. Pulling the ASSV handle out will disengage all chiller controlled operation. The ASSV handle should remain pushed in to ensure chiller control.

UNIT CONTROLLED PUMPS

This evaporator pump control routine is designed to provide freeze protection to the chiller evaporator tubes when exposed to low ambient during the time the chiller is not running. The purpose of activating the evaporator pump in low ambient conditions is to bring the warmer building liquid temperature into the evaporator, thus preventing freeze and increasing suction pressure. See unit IOM for installation details.

MINIMUM LIQUID VOLUME

It is good practice to include as much liquid volume as possible in a chilled liquid loop. This increases the thermal mass and “Flywheel” effect within the system (i.e. the more the better) which in turn promotes stable liquid temperature control and increases reliability by reducing compressor cycling.

Application Data (Cont'd)

For air conditioning applications, a minimum of 3 gallons/ton (3.2 liters/cooling kW) is recommended. It is preferred that the gallon/ton ratio be within the 5 to 8 (5.4 to 8.6 liter/cooling kW) range for constant flow rate chilled liquid systems. See "VARIABLE PRIMARY FLOW" on page 24 for recommendations for VPF systems. For process applications, a minimum of 6 gallons/ton (6.5 liter/cooling kW) ratio is recommended with preference towards a range of 7 to 11 gallons/ton (7.5 to 11.8 liter/cooling kW). Install a tank or increase pipe sizes to provide sufficient liquid volume.

LEAVING LIQUID TEMPERATURE OUT OF RANGE

The YVFA chiller line has a maximum leaving liquid temperature of 70°F (21.1°C). Some process applications require a chilled liquid temperature higher than what the chiller provides. In those applications, a simple piping change can remove the problem. By using a mixture of chiller-cooled liquid and returning process liquid, the chilled liquid entering the process can be held at the desired temperature. (A tank can also be used to meet high leaving liquid temperature requirements.) (See "Figure 7 - Leaving Liquid Temperature Out Of Range Suggested Layout" on page 23).

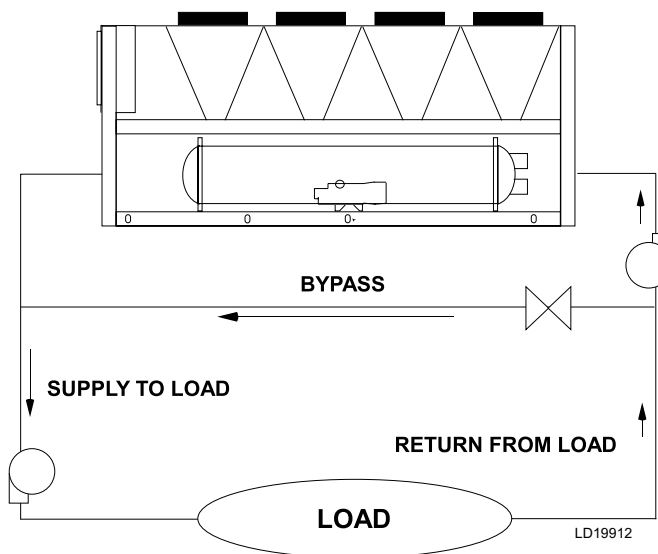

FIGURE 7 - LEAVING LIQUID TEMPERATURE OUT OF RANGE SUGGESTED LAYOUT

FLOW RATE OUT OF RANGE

Each YVFA chiller has a minimum and maximum flow rate. Some process applications require a flow rate that is out of range for the evaporator. In those applications, a piping change can remove the problem.

In applications where the required flow rate is less than the evaporator's minimum allowable, the chilled liquid can be recirculated to the chiller. (See "Figure 8 - Suggested Layout For Applications With A Flow Rate Greater Than The Maximum Allowable Flow Rate" on page 24).

Application Data (Cont'd)

In applications where the required flow rate is greater than the evaporator's maximum allowable, the chilled liquid can be recirculated to the load (see "Figure 8 - Suggested Layout For Applications With A Flow Rate Greater Than The Maximum Allowable Flow Rate" on page 24).

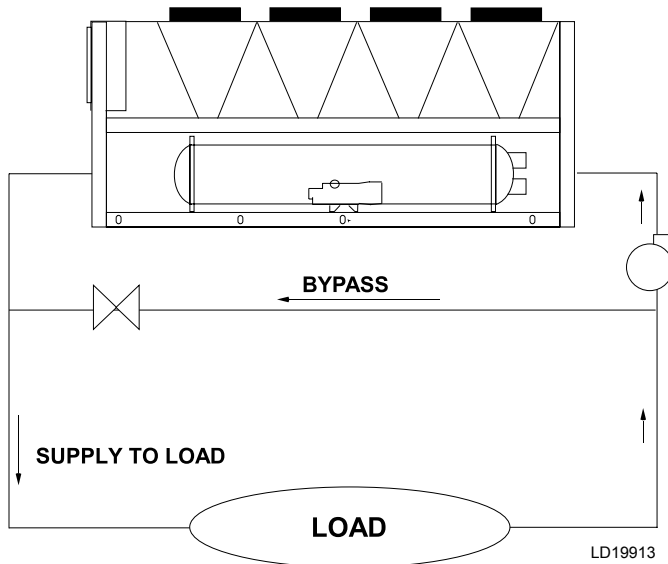

FIGURE 8 - SUGGESTED LAYOUT FOR APPLICATIONS WITH A FLOW RATE GREATER THAN THE MAXIMUM ALLOWABLE FLOW RATE

VARIABLE PRIMARY FLOW

Johnson Controls recommends a maximum 10% per minute flow rate of change, based on design flow, for variable primary flow applications. Eight to 10 gallons per chiller ton (8.6 to 10.8 liter per cooling kW) is recommended for the system liquid volume. Insufficient system volume and rapid flow changes can cause control problems or can even cause chiller shutdowns. There are many other design issues to evaluate with variable primary flow systems. Consult your Johnson Controls Sales Office for more information about successfully applying YVFA chillers.

Physical Data

MICROCHANNEL COIL - ENGLISH (SI)

The data shown in this table is applicable to selected typical configurations. Other configurations are available through our configuration/selection software. Please contact your nearest Johnson Controls Sales Office for the chiller configuration that best matches your specific needs.

UNIT FRAME	025/088	030/106	035/123
CONDENSER CODE	9	9	9
EVAPORATORS			
Min flow rate, glycol GPM (l/s) ¹	300 (19)	410 (26)	410 (26)
Max flow rate glycol, GPM (l/s) ¹	810 (51)	925 (58)	1040 (66)
COMPRESSORS			
Type	Semi-Hermetic Screw		
Number of Circuits	2		
Number of Compressors	2		
Refrigerant type	R-134a		
Refrigerant charge, lbs (kg)	250/225 (113/102)	310/265 (141/120)	310/310 (141/141)
Oil charge, gal (liters)	2.9/2.8 (11.1/10.5)	4.2/3.1 (15.9/11.7)	4.2/4.2 (15.9/15.9)
CONDENSER FANS			
Number of Fans (System 1/System 2)	8/6	9/7	9/9
Fan Power, 50Hz (kW)	42	48	54
Fan Power, 60Hz (kW)	36	42	47
Air flow, CFM (50Hz Units)	169,904	194,176	218,448
Air flow, CFM (60Hz Units)	171,500	196,000	220,500
PHYSICAL DATA			
Unit Length, inches (mm)	335.2 (8514)	379.2 (9631)	423.1 (10748)
Unit Width, inches (mm)	88.3 (2242)	88.3 (2242)	88.3 (2242)
Unit Height, inches (mm)	94.6 (2403)	94.6 (2403)	94.6 (2403)
Shipping weight, lbs (kg) ²	20367 (9238)	23045 (10453)	25131 (11399)
Operation weight, lbs (kg) ²	22907 (10390)	26013 (11799)	28686 (13012)

NOTES:

- Flow rates shown are for ethylene and propylene glycol.
- Shipping and operating weights shown are for base unit; selected options may add weight to unit. Contact your nearest Johnson Controls Sales office for weight data.

Physical Data (Cont'd)

YVFA0259/YVFA0889 UNIT DIMENSIONS

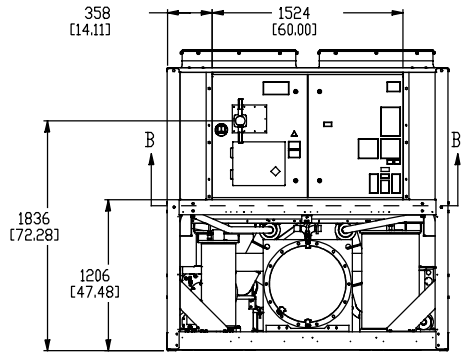
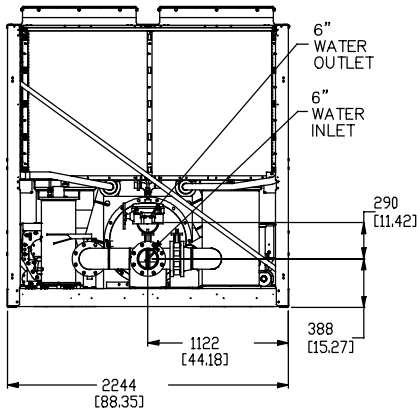
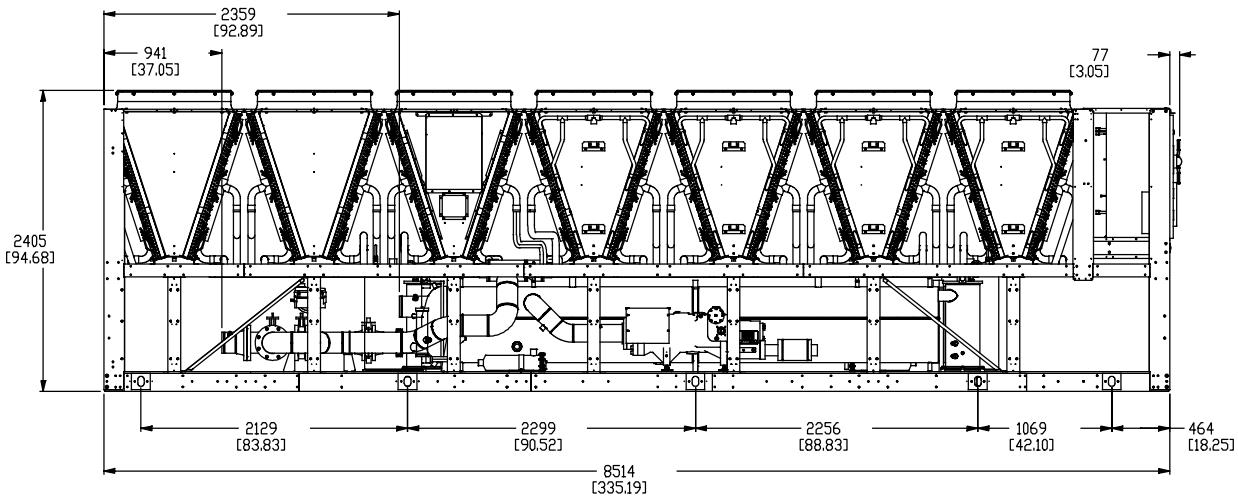

END VIEW

LD19939

Physical Data (Cont'd)

YVFA0259/YVFA0889 UNIT DIMENSIONS

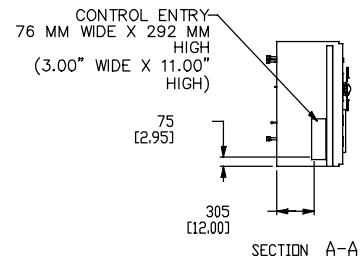
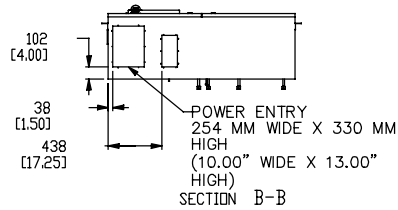
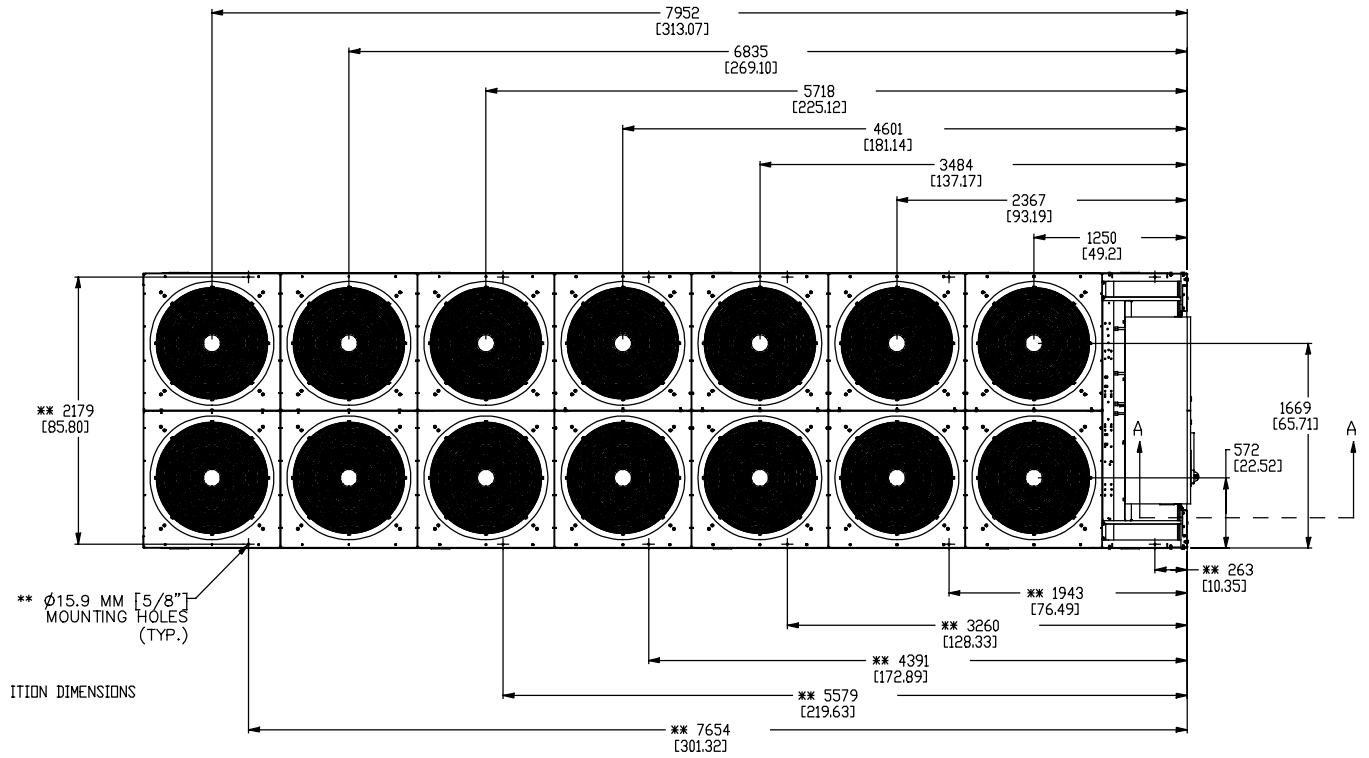

LD19940

Physical Data (Cont'd)

YVFA0309/YVFA1069 UNIT DIMENSIONS

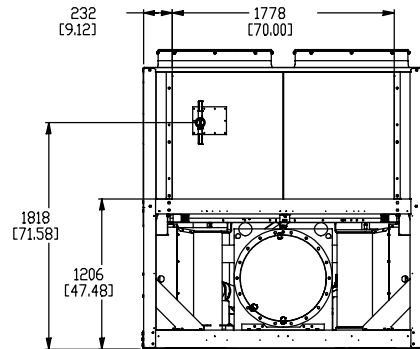
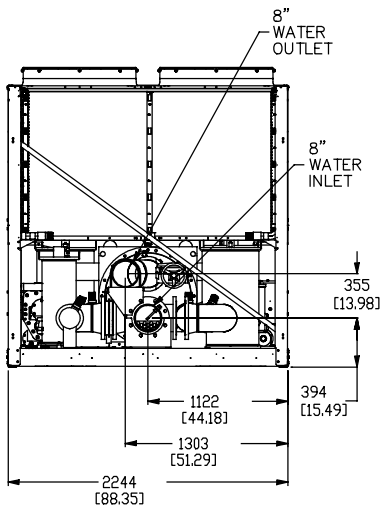
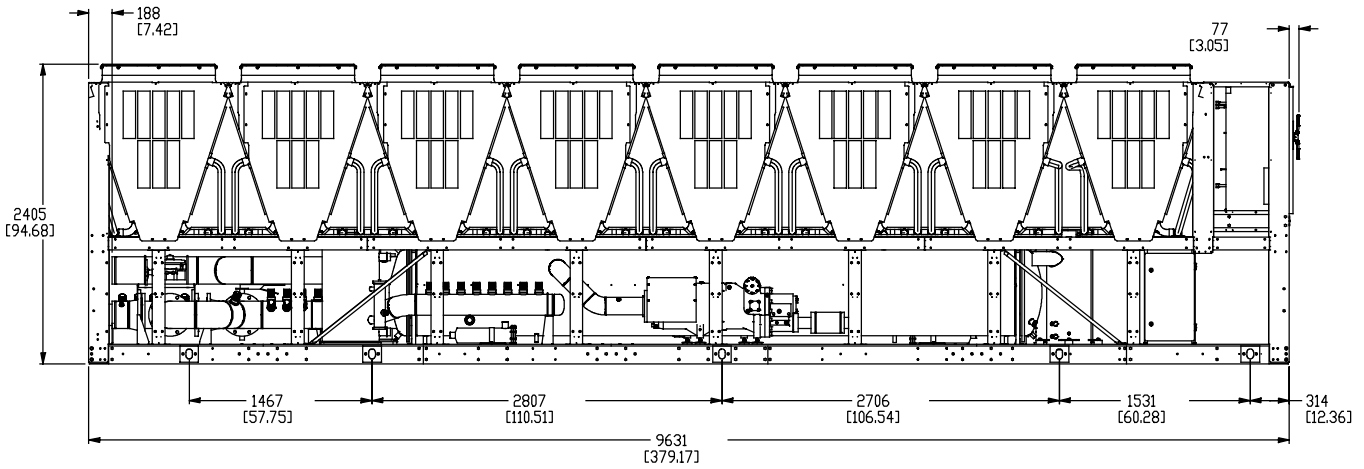

END VIEW

LD19941

Physical Data (Cont'd)

YVFA0309/YVFA1069 UNIT DIMENSIONS

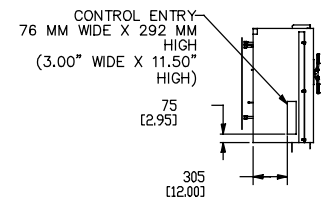
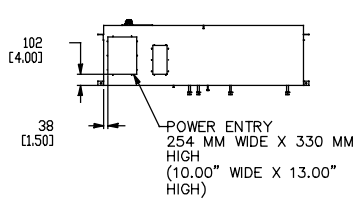
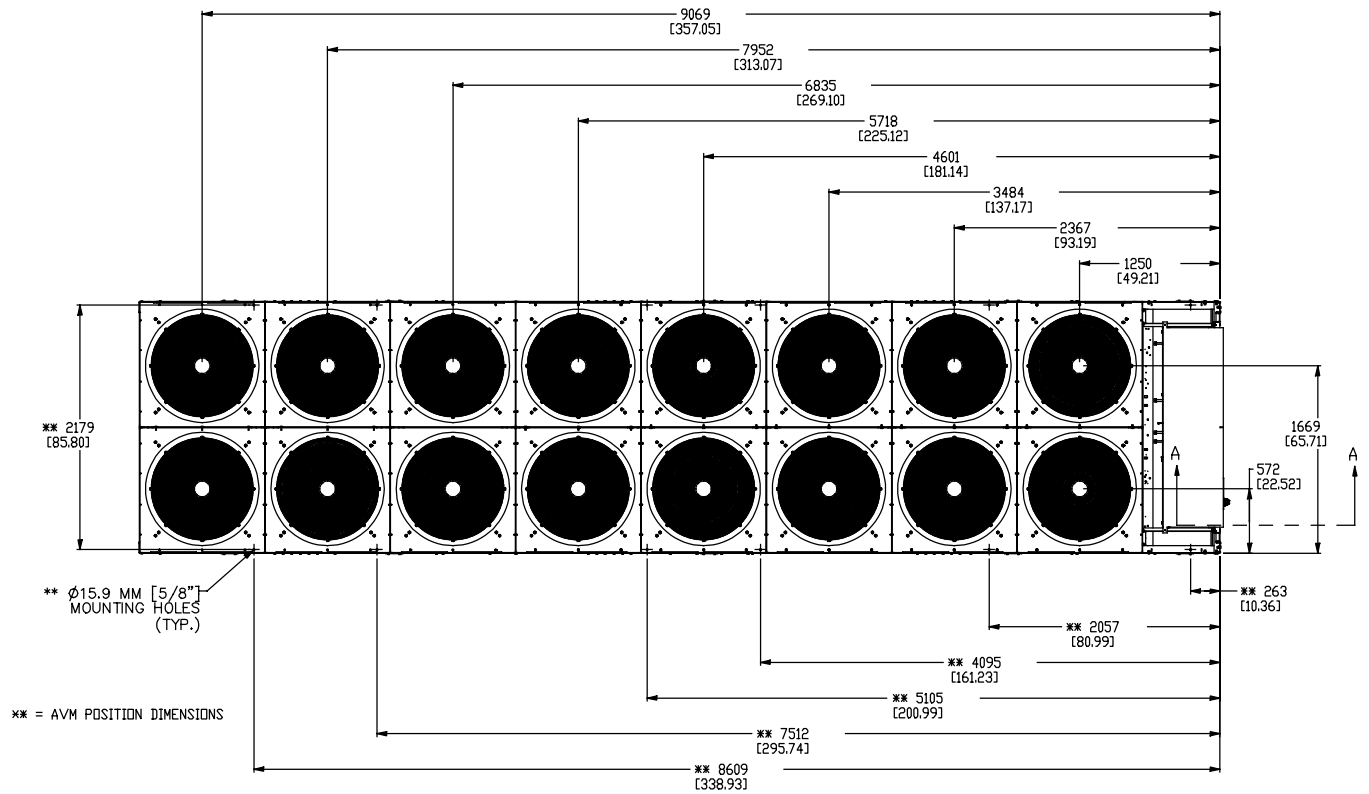

SECTION A-A

LD20132

Physical Data (Cont'd)

YVFA0359/YVFA1239 UNIT DIMENSIONS

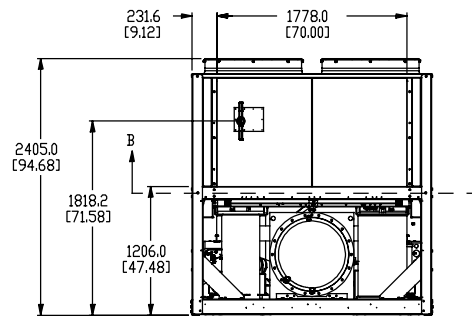
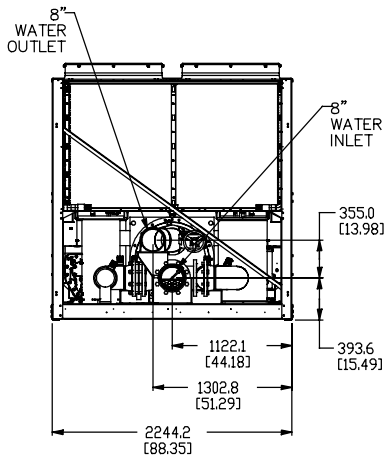
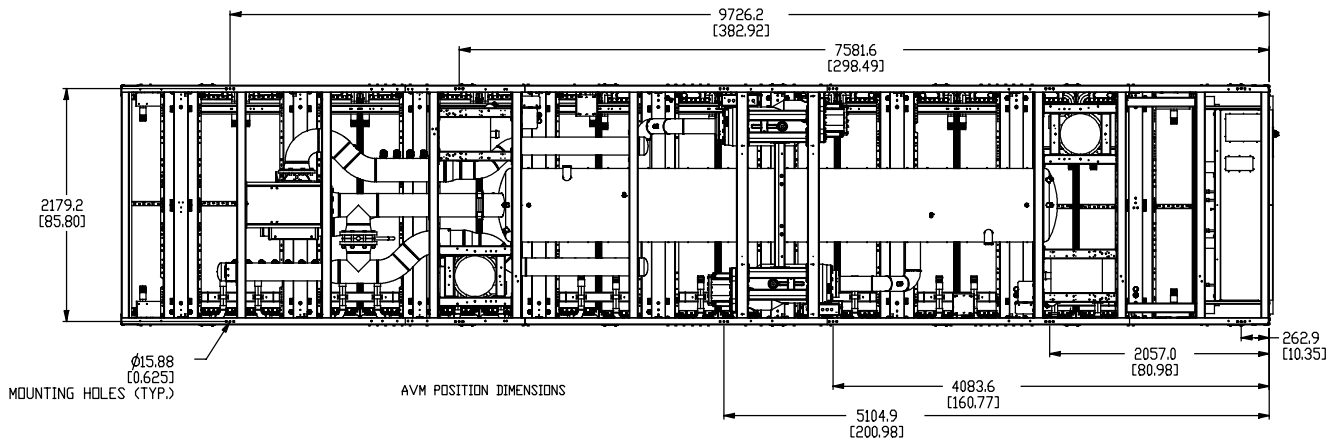
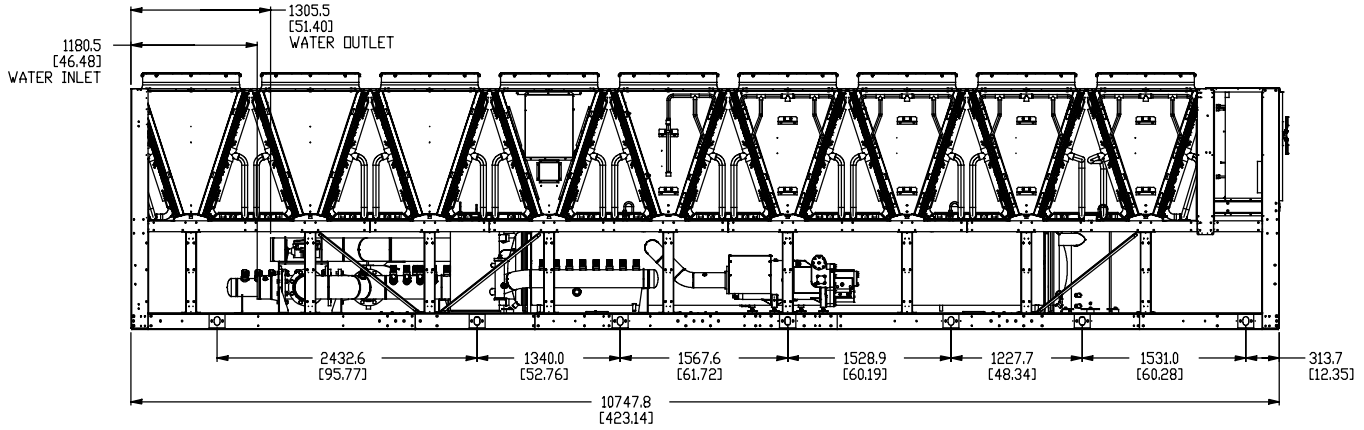

END VIEW

LD20133

Physical Data (Cont'd)

YVFA0359/YVFA1239 UNIT DIMENSIONS

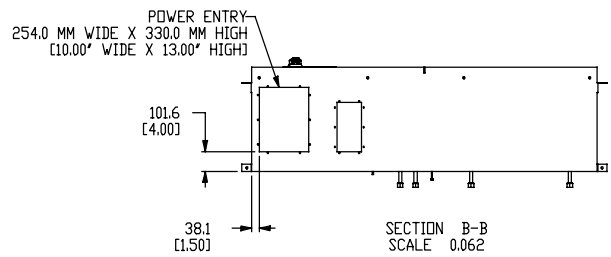
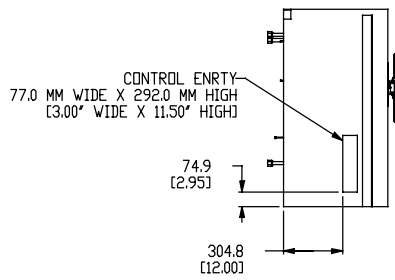
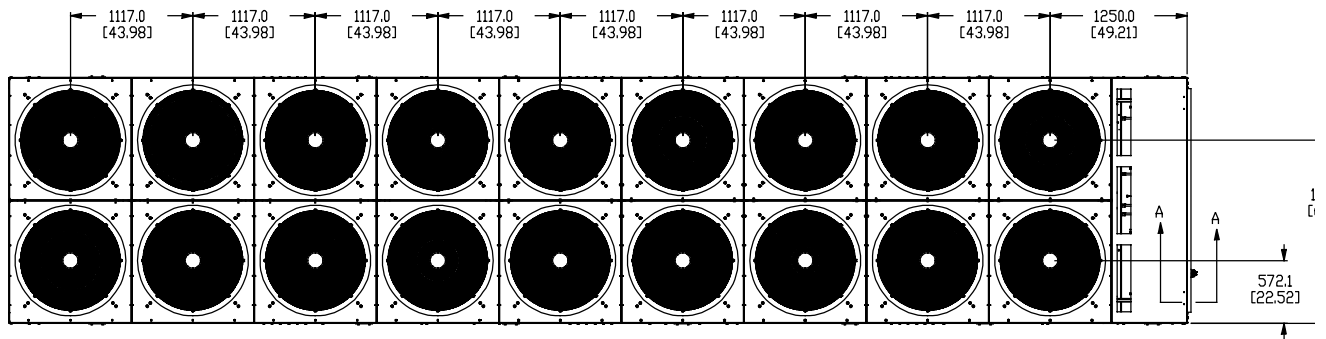

LD20134

Physical Data (Cont'd)

ELASTOMERIC ISOLATORS

RD-1, 2, AND 3 ISOLATORS

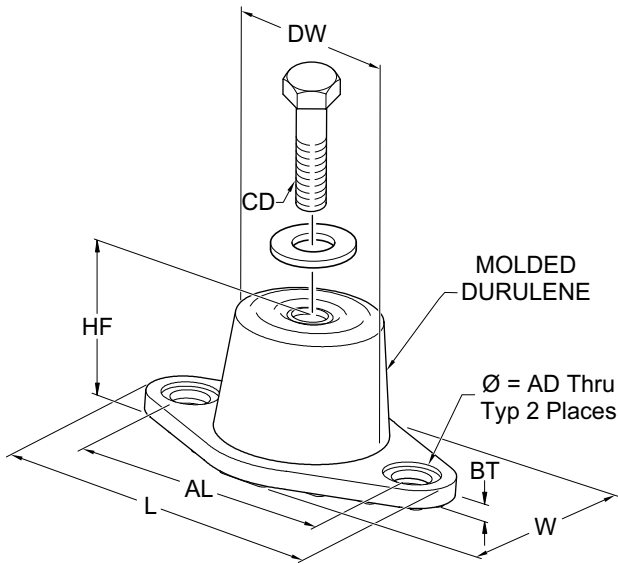

RD-4 ISOLATORS

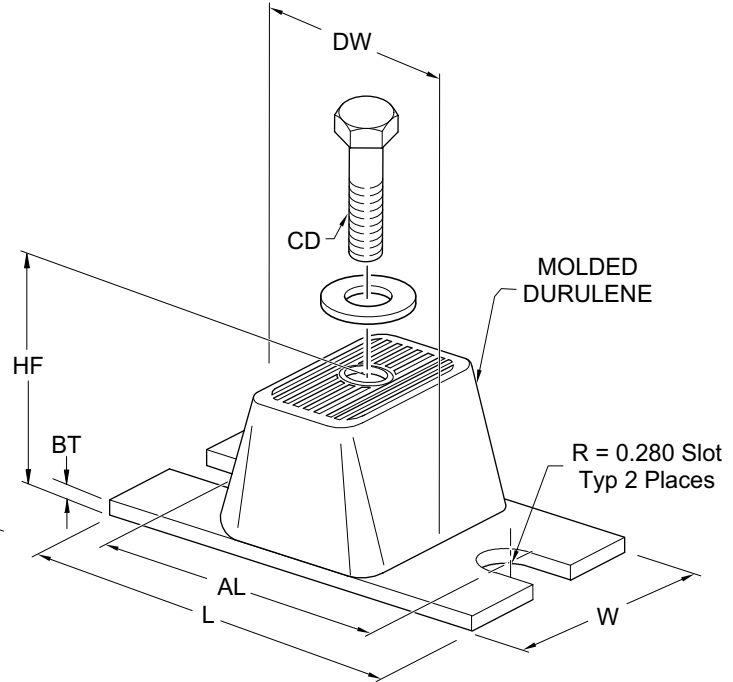

LD17304

MOUNT TYPE	DIMENSION DATA inches / (mm)							
	L	W	HF	AL	AD	BT	CD	DW
RD1-WR	3.13 (79.50)	1.75 (44.45)	1.25 (31.75)	2.38 (60.45)	0.34 (8.64)	0.19 (4.83)	5/16-18 UNC X 3/4 (M14 X 2)	1.25 (31.75)
RD2-WR	3.88 (98.55)	2.38 (60.45)	1.75 (44.45)	3.00 (76.20)	0.34 (8.64)	0.22 (5.59)	3/8-16 UNC X 1 (M18 X 2.5)	1.75 (44.45)
RD3-WR	5.50 (139.7)	3.38 (85.85)	2.88 (73.15)	4.13 (104.90)	0.56 (14.22)	0.25 (6.35)	1/2-13 UNC X 1 (M27 X 3)	2.50 (63.50)
RD4-WR	6.25 (158.75)	4.63 (117.6)	2.75 (69.85)	5.00 (127.00)	0.56 (14.22)	0.38 (9.65)	1/2-13 UNC X 1 (M27 X 3)	3.00 (76.20)

MODEL NUMBER	ISOLATOR COLOR	WEIGHT RANGE (LBS)	WEIGHT RANGE (KGS)
RD-3-CHARCOAL-WR	CHARCOAL	Up thru 825	UP TO 374
RD-4-BRICK RED-WR	BRICK RED	826 thru 1688	375 - 766
RD-4-CHARCOAL-WR	CHARCOAL	1689 thru 4000	767 - 1814

Physical Data (Cont'd)

ONE INCH DEFLECTION SPRING ISOLATOR (CPX-X-)

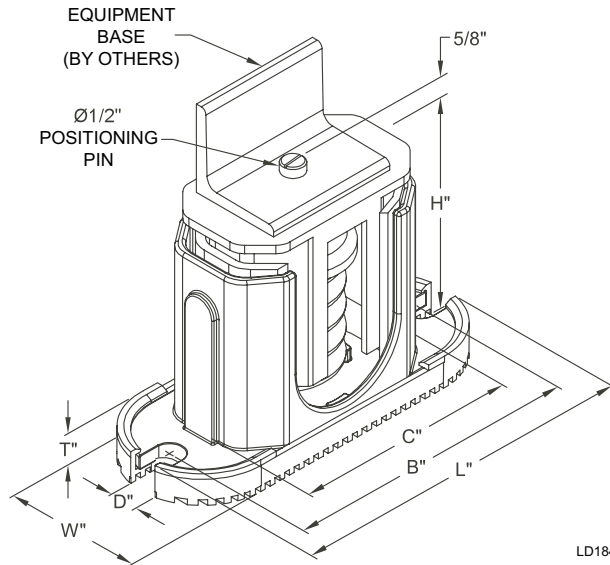

LD18443

MOUNT TYPE	DIMENSION DATA (INCHES)						
	W	D	L	B	C	T	H
CP1	3	5/8	7-3/4	6-1/2	4-3/4	1/2	5-5/8
CP2	3	5/8	10-1/2	9-1/4	7-3/4	9/16	6

MODEL NUMBER	COLOR CODE	RATED CAPACITY (FOR UNITS WITH ALL LOAD POINTS LESS THAN 1785 LBS (810 KG))	
		(LBS.)	(KG)
CP-1D-510	BLACK	Up thru 434	Up thru 197
CP-1D-900	DARK GREEN	435 thru 765	198 thru 347
CP-1D-1200	GRAY	766 thru 1020	348 thru 463
CP-1D-1360	WHITE	1021 thru 1156	464 thru 524
CP-1D-1785N	GRAY/RED	1157 thru 1785	525 thru 810

MODEL NUMBER	COLOR CODE	RATED CAPACITY (FOR UNITS WITH ANY LOAD POINT ABOVE 1518 LBS (689 KG))	
		(LBS.)	(KG)
C2P-1D-1350	DARK PURPLE	Up thru 1148	Up to 521
C2P-1D-1800	DARK GREEN	1149 thru 1530	522 - 694
C2P-1D-2400	GRAY	1531 thru 2040	695 - 925
C2P-1D-2720	WHITE	2041 thru 2312	926 - 1049
C2P-1D-3570N	GRAY/RED	2313 thru 3570	1050 - 1619

Electrical Data

FIELD WIRING LUGS				HIGH AIRFLOW CONDENSER FANS					
				TERMINAL BLOCK		CIRCUIT BREAKER		NON-FUSED DISCONNECT SWITCH	
YVFA MODEL		INPUT VOLTS	INPUT FREQ	WIRE PER PHASE	LUG WIRE RANGE	WIRES PER PHASE	LUG WIRE RANGE	WIRES PER PHASE	LUG WIRE RANGE
FRAME	COND								
SINGLE POINT WIRING									
25	9	200	60	4	1/0 - 700 kcmil				
		230	60	4	#2 - 600 kcmil	4	4/0 - 500 kcmil		
		380	60	3	#2 - 600 kcmil	3	3/0 - 400 kcmil	3	#2 - 600 kcmil
		400	50	3	3/0 - 400 kcmil	3	3/0 - 400 kcmil	3	#2 - 600 kcmil
		460	60	3	#2 - 600 kcmil	3	3/0 - 400 kcmil	3	#2 - 600 kcmil
30	9	575	60	2	#2 - 600 kcmil	2	#1 - 500 kcmil	2	#2 - 600 kcmil
		380	60	4	#2 - 600 kcmil	4	4/0 - 500 kcmil	4	#2 - 600 kcmil
		400	50	4	4/0 - 500 kcmil	4	4/0 - 500 kcmil	4	#2 - 600 kcmil
		460	60	3	#2 - 600 kcmil	4	4/0 - 500 kcmil	3	#2 - 600 kcmil
35	9	575	60	3	#2 - 600 kcmil	3	3/0 - 400 kcmil	3	#2 - 600 kcmil
		380	60	4	#2 - 600 kcmil	4	4/0 - 500 kcmil	4	#2 - 600 kcmil
		400	50	4	4/0 - 500 kcmil	4	4/0 - 500 kcmil	4	#2 - 600 kcmil
		460	60	3	#2 - 600 kcmil	4	4/0 - 500 kcmil	3	#2 - 600 kcmil
		575	60	3	#2 - 600 kcmil	3	3/0 - 400 kcmil	3	#2 - 600 kcmil

FIELD WIRING LUGS				HIGH AIRFLOW CONDENSER FANS					
				TERMINAL BLOCK		CIRCUIT BREAKER		NON-FUSED DISCONNECT SWITCH	
YVFA MODEL		INPUT VOLTS	INPUT FREQ	WIRE PER PHASE	LUG WIRE RANGE	WIRES PER PHASE	LUG WIRE RANGE	WIRES PER PHASE	LUG WIRE RANGE
FRAME	COND								
SINGLE POINT WIRING									
88	9	400	50	3	3/0 - 400 kcmil	3	3/0 - 400 kcmil	3	#2 - 600 kcmil
106	9	400	50	4	4/0 - 500 kcmil	4	4/0 - 500 kcmil	4	#2 - 600 kcmil
123	9	400	50	4	4/0 - 500 kcmil	4	4/0 - 500 kcmil	4	#2 - 600 kcmil

Wiring

SINGLE POINT WIRING

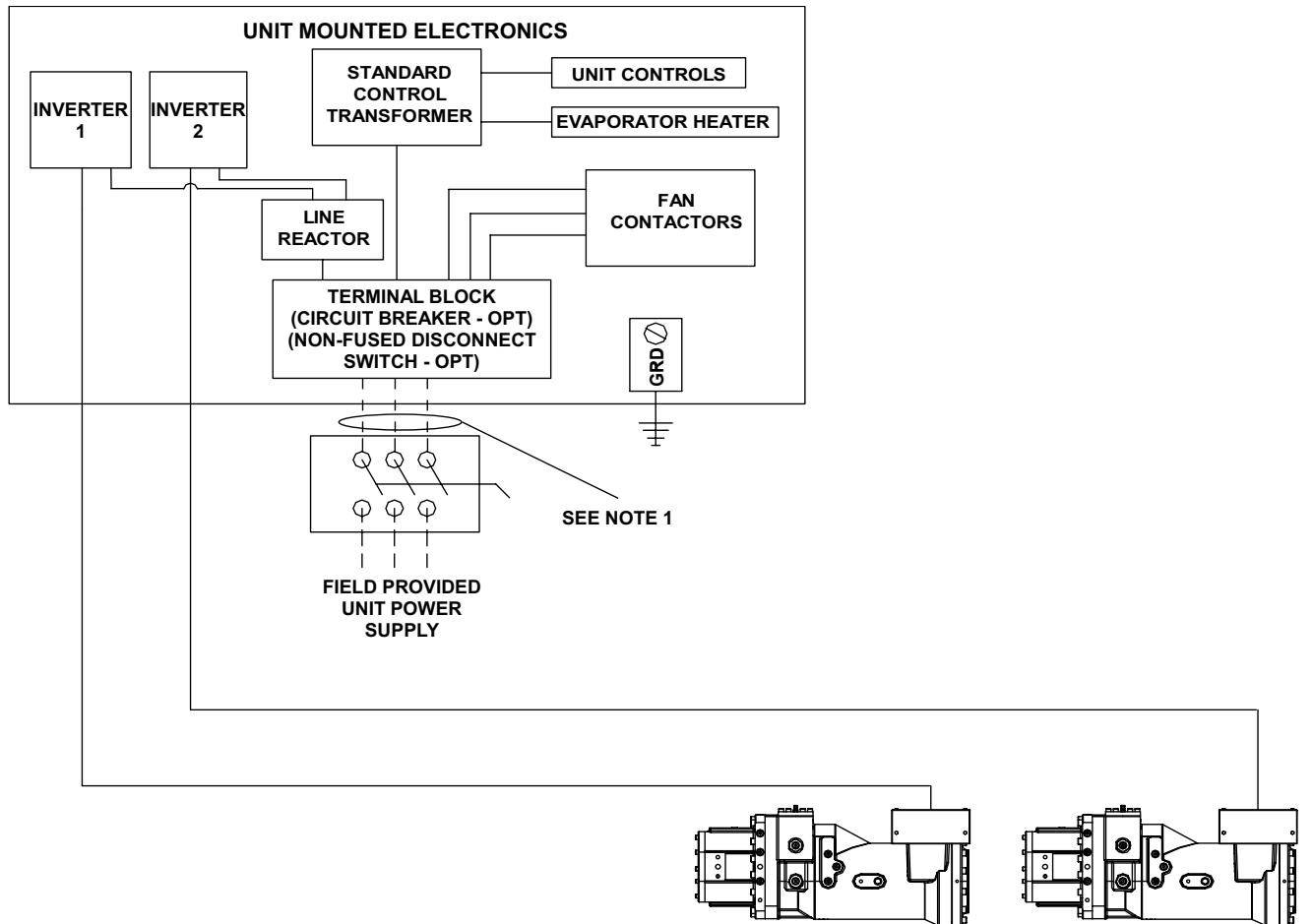

LD18588

Wiring (Cont'd)

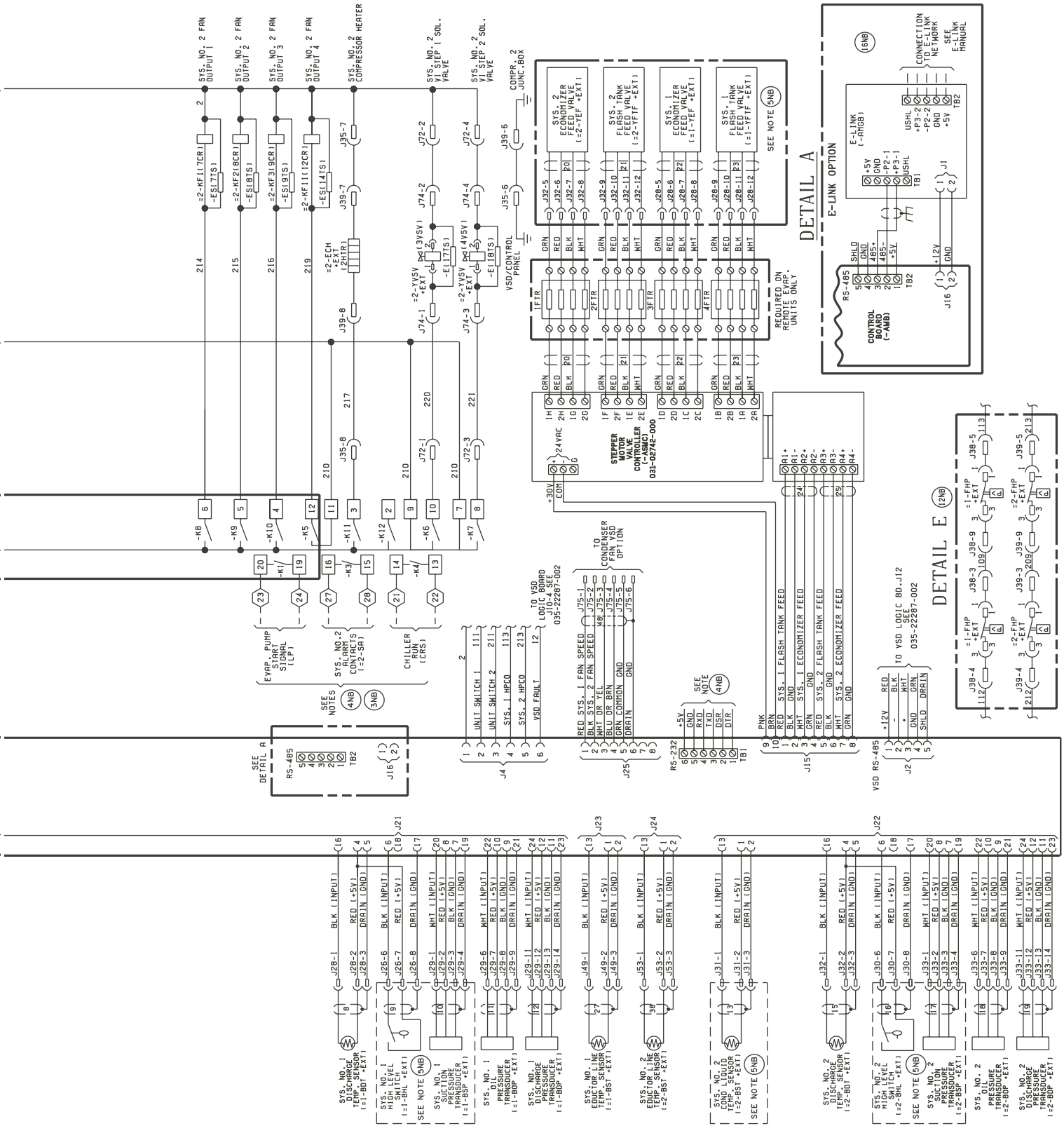

CONTROL WIRING

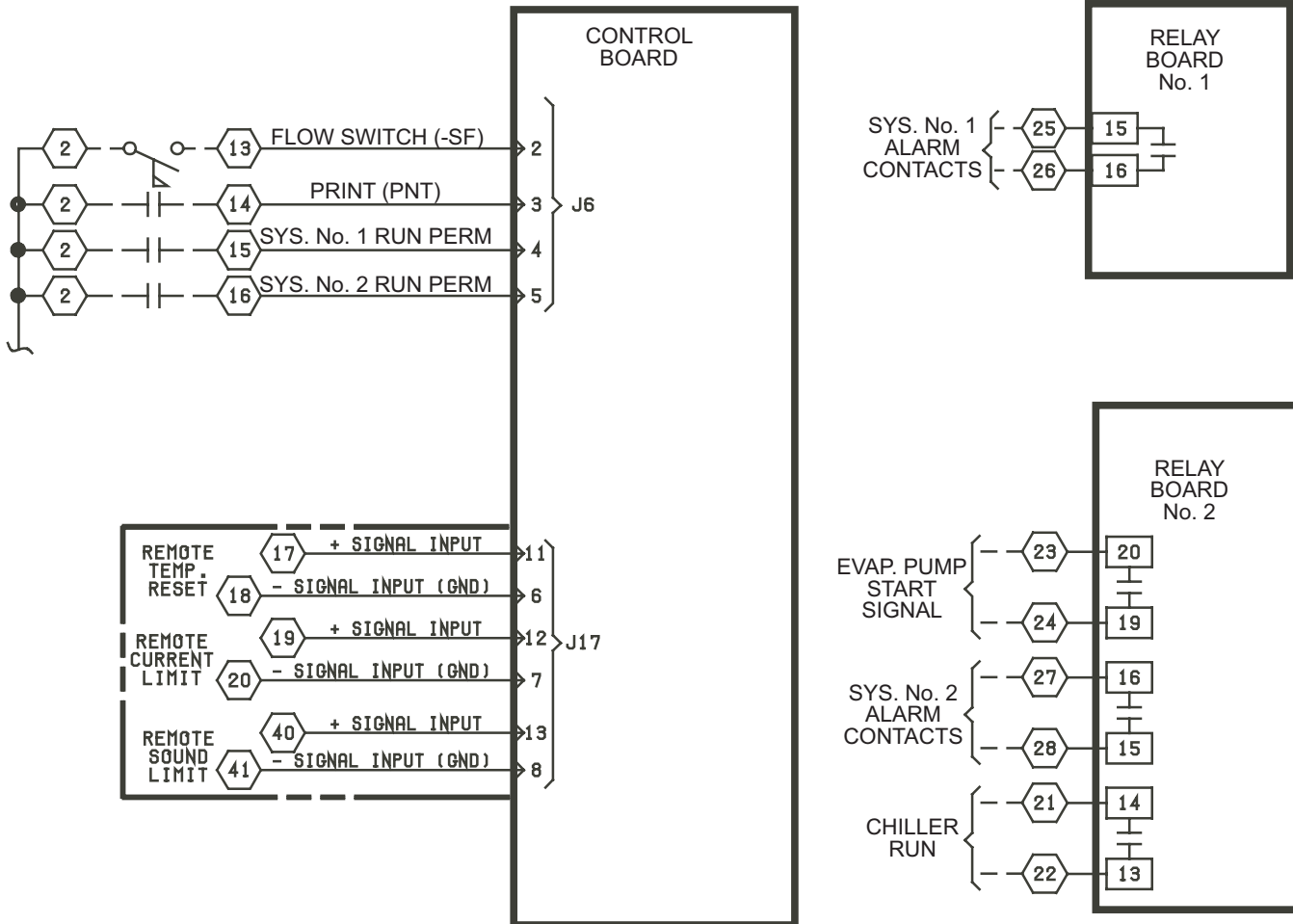

Wiring (Cont'd)

CUSTOMER CONTROL WIRING



- LEGEND**
-  TERMINAL BLOCK FOR CUSTOMER CONNECTIONS
 -  TERMINAL BLOCK FOR YORK CONNECTIONS
 - WIRING AND COMPONENTS BY YORK
 - OPTIONAL EQUIPMENT
 - WIRING AND/OR COMPONENTS BY OTHERS

Guide Specifications

PART 1 - GENERAL

1.01 GENERAL REQUIREMENTS

A. The requirements of this Section shall conform to the general provisions of the Contract, including General and Supplementary Conditions, Conditions of the Contract, and Contract Drawings.

1.02 SCOPE

A. Provide microprocessor controlled, twin-screw compressor, air-cooled, liquid chillers with auxiliary liquid cooling coils of the scheduled capacities as shown and indicated on the drawings, including but not limited to:

1. Chiller package
2. Charge of refrigerant and oil
3. Electrical power and control connections
4. Chilled liquid connections
5. Manufacturer start-up

1.03 QUALITY ASSURANCE

A. Products shall be designed, tested, rated and certified in accordance with, and installed in compliance with applicable sections of the following standards and codes:

1. AHRI 550/590 – Water Chilling Packages Using the Vapor Compression Cycle
2. AHRI 370 – Sound Rating of Large Outdoor Refrigerating and Air-Conditioning Equipment
3. ANSI/ASHRAE 15 – Safety Code for Mechanical Refrigeration
4. ANSI/ASHRAE 34 – Number Designation and Safety Classification of Refrigerants
5. ASHRAE 90.1 – Energy Standard for Buildings Except Low-Rise Residential Buildings
6. ANSI/NFPA 70 – National Electrical Code (N.E.C.)
7. ASME Boiler and Pressure Vessel Code, Section VIII, Division 1
8. OSHA – Occupational Safety and Health Act
9. Manufactured in facility registered to ISO 9001
10. Conform to Intertek Testing Services for construction of chillers and provide ETL/cETL Listed Mark

Guide Specifications (Cont'd)

1.04 DELIVERY AND HANDLING

- A. Unit shall be delivered to job site fully assembled with all interconnecting refrigerant piping and internal wiring ready for field installation and charged with refrigerant and oil by the Manufacturer.
- B. Provide protective covering over vulnerable components for unit protection during shipment. Fit nozzles and open ends with plastic enclosures.
- C. Unit shall be stored and handled per Manufacturer's instructions.

PART 2 - PRODUCTS

2.01 MANUFACTURERS

- A. The design shown on the drawings is based on YORK Model YVFA VSD screw chiller with integrated waterside economizer manufactured by Johnson Controls. Alternate equipment will be acceptable if the manufacturer's equipment meets the scheduled performance and complies with these specifications. If equipment manufactured by a manufacturer other than that scheduled is utilized, then the mechanical contractor shall be responsible for coordinating with the general contractor and all affected subcontractors to insure proper provisions for installation of the furnished unit. This coordination shall include, but not be limited to, the following:
 - 1. Structural supports for units.
 - 2. Piping size and connection/header locations.
 - 3. Electrical power requirements and wire/conduit and overcurrent protection sizes.
 - 4. Chiller physical size on plant layout.
 - 5. Site noise considerations.
 - 6. Annual Energy Cost Analysis including site location, building use profile, electrical and demand charges.
- B. The mechanical contractor shall be responsible for all costs incurred by the general contractor, subcontractors, and consultants to modify the building provisions to accept the furnished alternate equipment.
- C. The equipment manufacturer must specialize in the design and manufacture of the products specified and shall have a minimum of ten years of experience in supplying variable speed driven compressor technology on the type of equipment and refrigerant specified.

2.02 GENERAL

- A. Description: Furnish, install, and commission factory assembled, charged, and operational run tested air-cooled screw compressor chiller with integrated waterside economizer glycol coils as specified herein and shown on the drawings. Chiller shall include, but is not limited to: a complete system with multiple independent refrigerant circuits, semi hermetic twin screw compressors, tube-in-shell hybrid falling film type evaporator, air-cooled condenser, glycol economizer coils, R134a refrigerant, lubrication system, interconnecting wiring, safety and operating controls including capacity controller, control center, motor starting components, and special features as specified herein or required for safe, automatic operation.

Guide Specifications (Cont'd)

B. Operating Characteristics:

1. Provide low and high ambient temperature control options as required to ensure unit is capable of operation from -20°F to 125°F (-28.8°C to 46.1°C) ambient temperature.
2. Provide capacity control system capable of reducing unit capacity to 10% of full load for 2 compressor units. Compressor shall start in unloaded condition. Hot gas bypass shall not be acceptable to meet specified minimum load.

C. Cabinet: Unit panels, structural elements, control boxes and heavy gauge structural base shall be constructed of painted galvanized steel. All exposed sheet steel shall be coated with baked on powder paint to meet 500-hour salt spray test in accordance with the ASTM B117 standard.

D. Shipping: Unit shall ship in one piece and shall require installer to provide only a single evaporator inlet and outlet pipe connection. If providing chiller model that ships in multiple pieces, bid shall include all the material and field labor costs for factory authorized personnel to install a trim kit to connect the pieces as well as all interconnecting piping and wiring.

2.03 COMPRESSORS

A. Compressors: Shall be direct drive, semi hermetic, rotary twin-screw type, including: muffler, temperature actuated 'off-cycle' heater, rain-tight terminal box, discharge shut-off service valve and precision machined cast iron housing. Design working pressure of entire compressor, suction to discharge, shall be 350 Psig (24 barg) or higher. Compressor shall be U.L. and/or CE recognized.

[Optional]: Provide suction shut-off service valve for each compressor.

B. Compressor Motors: Refrigerant suction-gas cooled accessible hermetic compressor motor, full suction gas flow through 0.006" (0.1524 mm) maximum mesh screen, with inherent internal thermal overload protection and external current overload on all three phases.

C. Balancing Requirements: All rotating parts shall be statically and dynamically balanced.

D. Lubrication System: External oil separators with no moving parts, 450 psig (31 barg) design working pressure, and ETL and/or CE listing shall be provided on the chiller. Refrigerant system differential pressure shall provide oil flow through service replaceable, 0.5 micron, full flow, cartridge type oil filter internal to compressor. Filter bypass, less restrictive media, or oil pump not acceptable.

E. Capacity Control: Compressors shall start at minimum load. Provide Microprocessor control to command com-pressor capacity to balance compressor capacity with cooling load.

2.04 REFRIGERANT CIRCUIT COMPONENTS

A. Refrigerant: R-134a. Classified as Safety Group A1 according to ASHRAE 34.

[Optional]: EN 378-2 (Only when optional dual safety relief valves are fitted).

B. Equipment supplied shall comply with LEED Energy & Atmospheric Credit 4, Enhanced Refrigerant Management.

Guide Specifications (Cont'd)

- C. Each independent refrigerant circuit shall incorporate all components necessary for the designed operation including: liquid line shut-off valve with charging port, low side pressure relief device, removable core filter-drier and sight glass with moisture indicator.
- D. Chiller manufacturer shall provide an independent circuit for each compressor to provide maximum redundancy during chiller operation. If equipment does not have independent circuits per compressor, manufacturer shall provide owner one spare compressor of each unique size.
- E. Discharge lines shall be provided with manual compressor shut-off service valves.

2.05 HEAT EXCHANGERS

A. Evaporator:

1. Evaporator shall be tube-in-shell, hybrid falling film type to optimize efficiency and refrigerant charge. Tubes shall be high-efficiency, internally and externally enhanced type copper tubes with 0.035 inch (0.89 mm) minimum wall thickness at all intermediate tube supports to provide maximum tube wall thickness at the support area. Each tube shall be roller expanded into the tube sheets providing a leak proof seal, and be individually replaceable. Independent refrigerant circuits shall be provided per compressor.
2. Constructed, tested, and stamped in accordance with applicable sections of ASME pressure vessel code for minimum 235 Psig (16 barg) refrigerant side design working pressure and 150 Psig (10 barg) liquid side design working pressure.

[Optional]: Constructed, tested, and stamped in accordance with applicable sections of PED pressure vessel code for minimum 235 Psig (16 barg) refrigerant side design working pressure and 150 Psig (10 barg) liquid side design working pressure.

[Optional]: Constructed, tested, and stamped in accordance with applicable sections of GB pressure vessel code for minimum 235 Psig (16 barg) refrigerant side design working pressure and 150 Psig (10 barg) liquid side design working pressure.

3. Water boxes shall be removable to permit tube cleaning and replacement. Water boxes shall include liquid nozzle connections suitable for ANSI/AWWA C-606 grooved couplings, welding, or flanges.

[Optional]: Unit shall include 150 Psig (10.3 barg) ANSI raised-face flanges with ANSI/AWWA C-606 couplings. Flanges are field-mounted by Contractor. Companion flanges, bolts, nuts, and gaskets are not included.

[Optional]: Unit shall include 150 Psig (10.3 barg) ANSI raised-face flanges with ANSI/AWWA C-606 couplings with companion flanges. Flanges are field-mounted by Contractor. Bolts, nuts, and gaskets are not included.

4. Provide vent and drain fittings, and thermo-statically controlled heaters to protect to 0°F (-17.8°C) ambient temperature in off-cycle.

[Optional]: Provide thermo-statically controlled heaters to protect to -20°F (-28°C) ambient temperature in off-cycle. A separate power connection for evaporator heaters is required and shall be provided by the contractor.

Guide Specifications (Cont'd)

5. Connection location: Chilled liquid inlet and outlet nozzle connections are located at rear (opposite control panel) end of unit.

B. Air-cooled Condenser and Waterside Economizer Glycol Cooling Coils:

1. Condenser coils shall be micro-channel type, parallel flow aluminum alloy tubes metallurgically brazed as one piece to enhanced aluminum alloy fins. Condenser coils shall be made of a single material to avoid galvanic corrosion due to dissimilar metals. Tube and fin type condenser coils are an acceptable alternate. Condenser Coils shall be designed for 350 Psig (24 barg) or higher working pressure.

[Optional]: Coils shall be post-coated with an electro-deposited and baked flexible epoxy coating that is finished with a polyurethane UV resistant top-coat suitable for highly corrosive applications.

[Optional]: Unit shall include Wire Panels: Heavy gauge, welded wire mesh coated to resist corrosion, to protect condenser coils from incidental damage and also restrict unauthorized access to internal components. **[Optional]:** Unit shall include Louvered Panels (Condenser Coils): Painted steel to match unit panels, over external condenser coil faces.

[Optional]: Unit shall include Louvered Panels (Full Unit): Painted steel to match unit panels, over internal components.

[Optional]: Unit shall include Louvered/Wire Panels: Louvered steel panels on external condenser coil faces, painted to match unit panels. Heavy gauge, welded wire mesh, coated to resist corrosion, around base of machine to restrict unauthorized access.

[Optional]: Unit shall include V-Guard Panels: Steel panels installed over exposed condenser piping to protect from damage.

2. High Airflow Fans with Variable Speed Drives. All fans shall be powered by variable speed drive. Fans shall provide vertical air discharge from extended orifices. Fans shall be composed of corrosion resistant aluminum hub and glass-fiber-reinforced polypropylene composite blades molded into a low-noise airfoil section. Fan impeller shall be dynamically balanced for vibration-free operation. Fan guards of heavy gauge, PVC (polyvinyl chloride) coated or galvanized steel.
3. Fan Motors: High efficiency, direct drive, 3-phase, insulation class "F", current protected, Totally Enclosed Air-Over (TEAO), IP54 with double sealed, permanently-lubricated ball bearings. Open Drip Proof (ODP) fan motors will not be acceptable.

C. Integrated Waterside Economizer Heat Exchangers:

1. Integrated Waterside Economizer coils shall be seamless copper tubes mechanically expanded into aluminum alloy fins with full height collars. Design working pressure shall be 150 Psig (10.3 barg) or higher

[Optional]: Coils shall be post-coated with an electro-deposited and baked flexible epoxy coating that is finished with a polyurethane UV resistant top-coat suitable for highly corrosive applications.

2. Liquid inlet and outlet shall be single connection for simple field piping. Piping to connect evaporator and integrated waterside economizer coils shall be internal to the unit frame. All internal connections shall be factory connected.

Guide Specifications (Cont'd)

3. Unit shall be equipped with a valve to permit bypass of waterside economizer coils when ambient temperature is above liquid return temperature, to avoid unnecessary liquid pressure drop and reduce pumping power consumption. Valve shall be automatically controlled and powered by unit control panel.

2.06 INSULATION

- A. Material: Closed-cell, flexible, UV protected, thermal insulation complying with ASTM C 534 Type 2 (Sheet) for preformed flexible elastomeric cellular thermal insulation in sheet and tubular form.
- B. Thickness: 3/4 inch (19mm).
- C. Thermal conductivity: 0.26 (BTU/HR-Ft²-°F/in) maximum at 75°F mean temperature.
- D. Factory-applied insulation over cold surfaces of liquid chiller components including evaporator shell, water boxes, and suction line. Liquid nozzles shall be insulated by contractor after pipe installation.
- E. Adhesive: As recommended by insulation manufacturer and applied to 100 percent of insulation contact surface including all seams and joints.

2.07 ACOUSTICAL DATA

- A. Provide acoustical sound power or sound pressure level data in decibels (dB) at the scheduled eight (8) octave band center frequencies. A-weighted sound data alone is not acceptable.
- B. Provide all sound power or sound pressure level data at 100%, 75%, 50%, and 25% load.
- C. Supplied equipment shall not exceed scheduled sound power or sound pressure level data at any load point. The mechanical Contractor shall be responsible for any additional costs associated with equipment deviation.
- D. Acoustical performance ratings shall be in accordance with AHRI Standard 370.

[Optional]: Acoustical performance ratings shall be in accordance with ISO 9614.

[Optional]: Provide factory-installed sound reduction enclosures surrounding compressor to meet chiller sound levels scheduled at all load points.

2.08 POWER AND ELECTRICAL REQUIREMENTS

- A. Power/Control Panel:
 1. Factory installed and wired NEMA 3R / IP55, powder painted steel cabinets with tool lockable, hinged, latched, and gasket sealed outer doors equipped with wind struts for safer servicing. Provide main power connection(s), compressor starters and fan motor contactors, current overloads, and factory wiring.
 2. Panel shall include control display access door.

Guide Specifications (Cont'd)

B. Single Point Power:

1. Provide single point power connection to chiller, shall be 3 phase of scheduled voltage.
2. Terminal Block connections shall be provided at the point of incoming single point connection for field connection and interconnecting wiring to the compressors. Separate external protection must be supplied, by others, in the incoming power wiring, which must comply with local codes.

[Optional]: Single Point Disconnect: A non-fused disconnect and lockable external handle shall be provided at the point of incoming single point connection for field connection, interconnecting wiring to the compressors, and isolating the unit power voltage for servicing. Separate external fusing must be supplied, by others, in the incoming power wiring which must comply with local codes.

[Optional]: Single Point Circuit Breaker: A unit-mounted Circuit Breaker with external lockable handle shall be provided at the point of incoming single point connection for field connection, interconnecting wiring to the compressors, and isolating the power voltage for servicing. Incoming power wiring must comply with local codes. Circuit breaker shall be sized to provide the motor branch circuit protection, short circuit protection and ground fault protection for the motor branch-circuit conductors, the motor control apparatus and the motors.

C. Control Transformer: Power panel shall be supplied with a factory mounted and wired control transformer that will supply all unit control voltage from the main unit power supply. Transformer shall utilize scheduled line voltage on the primary side and provide 115 V/1Ø on secondary.

D. Short Circuit Withstand Rating of the chiller electrical enclosure shall be (380, 400, & 460 V): 30,000 Amps.

[Optional]: Short Circuit Withstand Rating of the chiller electrical enclosure shall be (380, 400, & 460 V): 50,000 Amps

[Optional]: Short Circuit Withstand Rating of the chiller electrical enclosure shall be (380, 400, & 460 V): 65,000 Amps. Rating shall be published in accordance with UL508.

[Optional]: Rating shall be published in accordance EN 60204-1

E. Motor Starters: Motor starters shall be Variable Frequency Drive type with zero electrical inrush current. Wye-Delta, Solid State, and Across the Line type starters will not be acceptable.

F. Power Factor:

1. Provide equipment with power factor correction capacitors as required to maintain a displacement power factor of 95% at all load conditions.
2. The installing contractor is responsible for additional cost to furnish and install power factor correction capacitors if they are not factory mounted and wired.

G. All exposed power wiring shall be routed through liquid-tight, UV-stabilized, non-metallic conduit.

H. Supplied equipment shall not exceed scheduled Minimum Circuit Ampacity (MCA). The mechanical Contractor shall be responsible for any additional costs associated with equipment deviation.

Guide Specifications (Cont'd)

2.09 CONTROLS

A. General:

1. Provide automatic control of chiller and waterside economizer operation including compressor start/stop and load/unload, anti-recycle timers, condenser fans, evaporator pump, evaporator heater, waterside economizer bypass valve, unit alarm contacts and run signal contacts.
2. Chiller shall automatically reset to normal chiller operation after power failure.
3. Unit operating software shall be stored in non-volatile memory. Field programmed set points shall be retained in lithium battery backed regulated time clock (RTC) memory for minimum five years.
4. Alarm contacts shall be provided to remote alert for any unit or system safety fault.

B. Display and Keypad:

1. Provide minimum 80 character liquid crystal display that is both viewable in direct sunlight and has LED backlighting for nighttime viewing. Provide one keypad and display panel per chiller.
2. Display and keypad shall be accessible through display access door without opening main control/electrical cabinet doors.
3. Display shall provide a minimum of unit setpoints, status, electrical data, temperature data, pressures, safety lockouts and diagnostics without the use of a coded display.
4. Descriptions in English (or available language options), numeric data in English (or Metric) units.
5. Sealed keypad shall include unit On/Off switch.

C. Programmable Setpoints (within manufacturer limits): Display language, chilled liquid cooling mode, local/remote control mode, display units mode, system lead/lag control mode, remote temperature reset, remote current limit, remote sound limit, low ambient temperature cutout enable/disable, leaving chilled liquid setpoint and range, maximum remote temperature reset.

D. Display Data: Chilled liquid leaving and entering temperatures; outside ambient air temperature; lead system; evaporator pump status; active remote control; compressor suction, discharge, and oil pressures per refrigerant circuit; compressor discharge, motor, and oil temperatures per refrigerant circuit; saturation temperatures per refrigerant circuit; compressor speed; condenser fan status; condenser subcooling temperature; condenser drain valve percentage open; compressor capacity in percentage of full load amps; compressor number of starts; run time; operating hours; evaporator heater status; history data for last ten shutdown faults; history data for last 20 normal (non-fault) shutdowns.

E. Predictive Control Points: Unit controls shall avoid safety shutdown when operating outside design conditions by optimizing the chiller controls and cooling load output to stay online and avoid safety limits being reached. The system shall monitor the following parameters and maintain the maximum cooling output possible without shutdown of the equipment: motor current, suction pressure, discharge pressure, starter internal ambient temperature, and starter baseplate temperature.

Guide Specifications (Cont'd)

- F. System Safeties: Shall cause individual compressor systems to perform auto-reset shut down if: high discharge pressure or temperature, low suction pressure, low motor current,
- G. high/low differential oil pressure, low discharge superheat, high motor temperature, system control voltage.
- H. Unit Safeties: Shall be automatic reset and cause compressors to shut down if: high or low ambient temperature, low leaving chilled liquid temperature, under voltage, flow switch operation. Contractor shall provide flow switch and wiring per chiller manufacturer requirements.
- I. Manufacturer shall provide any controls not listed above, necessary for automatic chiller operation. Mechanical Contractor shall provide field control wiring necessary to interface sensors to the chiller control system.

2.10 ACCESSORIES AND OPTIONS

Some accessories and options supersede standard product features. All options are factory-mounted unless otherwise noted.

A. CONTROLS OPTIONS:

1. Building Automation System Interface: Chiller to accept 4 to 20 mA or 0 to 10 VDC input from BAS (by others) to reset the leaving chilled liquid temperature setpoint.
2. Building Automation System Interface: Chiller to accept 4 to 20 mA or 0 to 10 VDC input from BAS (by others) to reset the load limit setpoint.
3. Building Automation System Interface: Chiller to accept 4 to 20 mA or 0 to 10 VDC input from BAS (by others) to reset the leaving chilled liquid temperature and load limit setpoints.
4. Gateway: Provides communication for Building Automation Systems, including BACnet (MS/TP), Modbus, N2, and LON. **(Field commissioned by BAS manufacturer.)**

B. GENERAL OPTIONS:

1. Solid state thermal dispersion flow switch with stainless steel probe and IP 67 housing with LED status indicator of flow and output condition. 300 Bar pressure rating, -13 to 176°F (-25 to 80°C) ambient temperature range. **(Field mounted by contractor.)**
2. Differential Pressure Switch: 3-45 Psig (0.2-3 barg) range with 1/4" NPTE pressure connections. **(Field Mounted by contractor.)**
3. Chicago Code Relief Valve – Special relief valves per Chicago Code
4. Dual pressure relief valves – Two safety relief valves mounted in parallel; one is always operational. Pressure relief valves on both low and high pressure sides. Option available for ETL units only.
5. Special Requirement Documents:
 - a. Special Requirement Document Package (SRDP) includes Pressure Vessel Report, Unit Run Test Report, Production System Check Sheet and Final Unit Inspection Check Sheet.

Guide Specifications (Cont'd)

- b. Materials Package includes steel mill material reports for vessels in addition to Pressure Vessel Report, Unit Run Test Report, Production System Check Sheet and Final Unit Inspection Check Sheet

C. Vibration Isolation (All options field mounted by contractor):

- a. Provide Elastomeric Isolators.
- b. Provide 1 inch deflection spring isolators: Level adjustable, spring and cage type isolators for mounting under the unit base rails.

PART 3 - EXECUTION

3.01 INSTALLATION

- A. General: Rig and install in full accordance with manufacturer's requirements, project drawings, and contract documents.
- B. Location: Locate chiller as indicated on drawings, including cleaning and service maintenance clearance per manufacturer instructions. Adjust and level chiller on support structure.
- C. Components: Installing contractor shall provide and install all auxiliary devices and accessories for fully operational chiller.
- D. Electrical: Coordinate electrical requirements and connections for all power feeds with electrical contractor.
- E. Controls: Coordinate all control requirements and connections with controls contractor.
- F. Finish: Installing contractor shall paint damaged and abraded factory finish with touch-up paint matching factory finish.

Notes

