

 BY JOHNSON CONTROLS	MEDIUM VOLTAGE SOLID STATE STARTER	
OPERATION	Supercedes 160.00-05 (706)	Form 160.00-05 (1108)

**MEDIUM VOLTAGE 4160V & 2300V, 60Hz & 3300V, 50Hz
SOLID STATE STARTERS for YK and YT CHILLER APPLICATIONS**

CURRENT-GUARD® STARTER



IMPORTANT!

READ BEFORE PROCEEDING!

GENERAL SAFETY GUIDELINES

This equipment is a relatively complicated apparatus. During installation, operation, maintenance or service, individuals may be exposed to certain components or conditions including, but not limited to: refrigerants, oils, materials under pressure, rotating components, and both high and low voltage. Each of these items has the potential, if misused or handled improperly, to cause bodily injury or death. It is the obligation and responsibility of operating/service personnel to identify and recognize these inherent hazards, protect themselves, and proceed safely in completing their tasks. Failure to comply with any of these requirements could result in serious damage to the equipment and the property in

which it is situated, as well as severe personal injury or death to themselves and people at the site.

This document is intended for use by owner-authorized operating/service personnel. It is expected that this individual possesses independent training that will enable them to perform their assigned tasks properly and safely. It is essential that, prior to performing any task on this equipment, this individual shall have read and understood this document and any referenced materials. This individual shall also be familiar with and comply with all applicable governmental standards and regulations pertaining to the task in question.

SAFETY SYMBOLS

The following symbols are used in this document to alert the reader to areas of potential hazard:



DANGER indicates an imminently hazardous situation which, if not avoided, will result in death or serious injury.



CAUTION identifies a hazard which could lead to damage to the machine, damage to other equipment and/or environmental pollution. Usually an instruction will be given, together with a brief explanation.



WARNING indicates a potentially hazardous situation which, if not avoided, could result in death or serious injury.

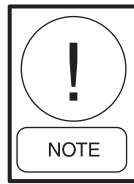

NOTE is used to highlight additional information which may be helpful to you.



External wiring, unless specified as an optional connection in the manufacturer's product line, is NOT to be connected inside the equipment cabinet. Devices such as relays, switches, transducers and controls may NOT be installed inside the unit. NO external wiring is allowed to be run through the unit. All wiring must be in accordance with YORK's published specifications and must be performed ONLY by qualified YORK personnel. YORK will not be responsible for damages/problems resulting from improper connections to the controls or application of improper control signals. Failure to follow this will void the manufacturer's warranty and cause serious damage to property or injury to persons.



DANGER
HIGH VOLTAGE

HAZARD OF ELECTRICAL SHOCK

LINE VOLTAGE PRESENT ON COMPONENTS AND TERMINALS IN THIS ENCLOSURE. MORE THAN ONE DISCONNECT SWITCH MAY BE REQUIRED TO DE-ENERGIZE THE EQUIPMENT FOR SERVICING. NOTE - LINE SIDE OF UNIT DISCONNECTS ARE LIVE UNLESS INCOMING SUPPLY VOLTAGE IS INTERRUPTED.



DANGER

HIGH VOLTAGE - KEEP OUT

DO NOT REMOVE COVERS, OPEN DOORS OR WORK ON THIS EQUIPMENT - UNLESS YOU COMPLY WITH ALL OF THE FOLLOWING:

1. Electric voltage & power has been turned off.
2. You are qualified & knowledgeable of this equipment.

CUT OFF POWER - LOCK OUT - TAG - PROPERLY GROUND ALL CIRCUITS BEFORE WORKING ON THIS EQUIPMENT. USE PROPER SAFETY PRECAUTIONS.

TABLE OF CONTENTS

GENERAL SAFETY GUIDELINES	2
SAFETY SYMBOLS	2
MV-SSS REQUIREMENTS	5
UNIT MODEL NOMENCLATURE	6
MV-SSS OVERVIEW	7
SECTION 1 – THEORY OF OPERATION	8
SECTION 2 – SYSTEM ARCHITECTURE	10
GENERAL	12
POWER FUSES	12
CONTROL TRANSFORMER	13
3-PHASE VOLTAGE DIVIDER	13
CONTACTORS	13
SCR POWER STACK ASSEMBLIES	14
SECTION 3 – MV-SSS INTERNAL COMPONENTS	15
CONTROLLER BOARD	15
FIBER OPTIC TRANSMITTER BOARD	15
GATE DRIVER BOARDS	16
SCR HEATSINK POWER STACK ASSEMBLY	16
VOLTAGE DIVIDER BOARD	17
SECTION 4 – INSTALLATION	18
INSPECTION	18
GENERAL	18
SAFETY PRECAUTIONS	18
STARTER LOCATION	18
ELECTRICAL CONNECTION	18
CONTROL WIRING	19
POWER WIRING	19
SECTION 5 – STARTER FAULTS	22
DETAILED EXPLANATION OF MV-SSS CONTROLLER BOARD FAULTS	24
SECTION 6 – TROUBLESHOOTING	26

LIST OF TABLES

TABLE 1 – CT RATIOS	15
TABLE 2 – FAULT MESSAGES	22
TABLE 3 – GENERAL TROUBLESHOOTING	26

LIST OF FIGURES

FIG. 1 – FRONT VIEW, EXTERIOR	7
FIG. 2 – BASIC BLOCK DIAGRAM	9
FIG. 3 – MOTOR LEAD	10
FIG. 4 – R - TYPE FUSES	10
FIG. 5 – LOW VOLTAGE COMPARTMENT	11
FIG. 6 – MEDIUM VOLTAGE COMPARTMENT	11
FIG. 7 – LEXAN VIEWING WINDOW	12
FIG. 8 – CONTROL TRANSFORMER	13
FIG. 9 – 3-PHASE VOLTAGE DIVIDER	13
FIG. 10 – IN-LINE / BYPASS CONTACTORS	13
FIG. 11 – SCR POWER STACK ASSEMBLY	14
FIG. 12 – CONTROLLER BOARD	14
FIG. 13 – OUTGOING TERMINATION BUS	14
FIG. 14 – CONTROLLER BOARD	15
FIG. 15 – FIBER OPTIC TRANSMITTER BOARD	15
FIG. 16 – GATE DRIVER BOARD	16
FIG. 17 – SCR HEATSINK POWER STACK CURRENT FLOW	16
FIG. 18 – DIVIDER / CONTROLLER RESISTORS	17
FIG. 19 – MODBUS CONNECTIONS	19
FIG. 20 – INCOMING POWER LANDING PAD	19
FIG. 21 – OIL PUMP WIRING	19
FIG. 22 – 36" CABINET ELECTRICAL CONNECTIONS / UNIT CLEARANCES	20
FIG. 23 – 72" CABINET ELECTRICAL CONNECTIONS / UNIT CLEARANCES	21
FIG. 24 – CONTROLLER BOARD FAULT MESSAGE	22

MV-SSS REQUIREMENTS

Nominal Rated Voltage-	4160	3300	2300
Maximum Continuous Voltage-	4576	3630	2530
Minimum Continuous Voltage-	3744	2970	2070
Maximum Voltage Dip-	10%	10%	10%
Absolute Minimum Voltage-	3536	2805	1955
Frequency-	60Hz +/-2Hz	50Hz +/-2Hz	60Hz +/-2Hz
Frequency Rate of Change-	10Hz / sec.	10Hz / sec.	10Hz / sec.
Maximum Phase Unbalance-	3%	3%	3%
Interrupting Capacity-	50KA	50KA	50KA

% THD - Output THD does NOT exceed input THD once start sequence is started.

Overload - 105% Full Load RMS current for 40 seconds.

Anti-recycle Time - Minimum 20 minutes between starts.

Efficiency - 99.5% at rated input voltage and load.

Code Approval - CSA, UL, and CE.

Environmental - 32°F to 104°F (0°C to 40°C), max. 95% humidity, non-condensing, 5000' (1524m) altitude.

Enclosure - NEMA 1, IP20, IEC-529.

UNIT MODEL NUMBER NOMENCLATURE

MVSSS 0 8 5 3 R T 0 4 2 - 8 0

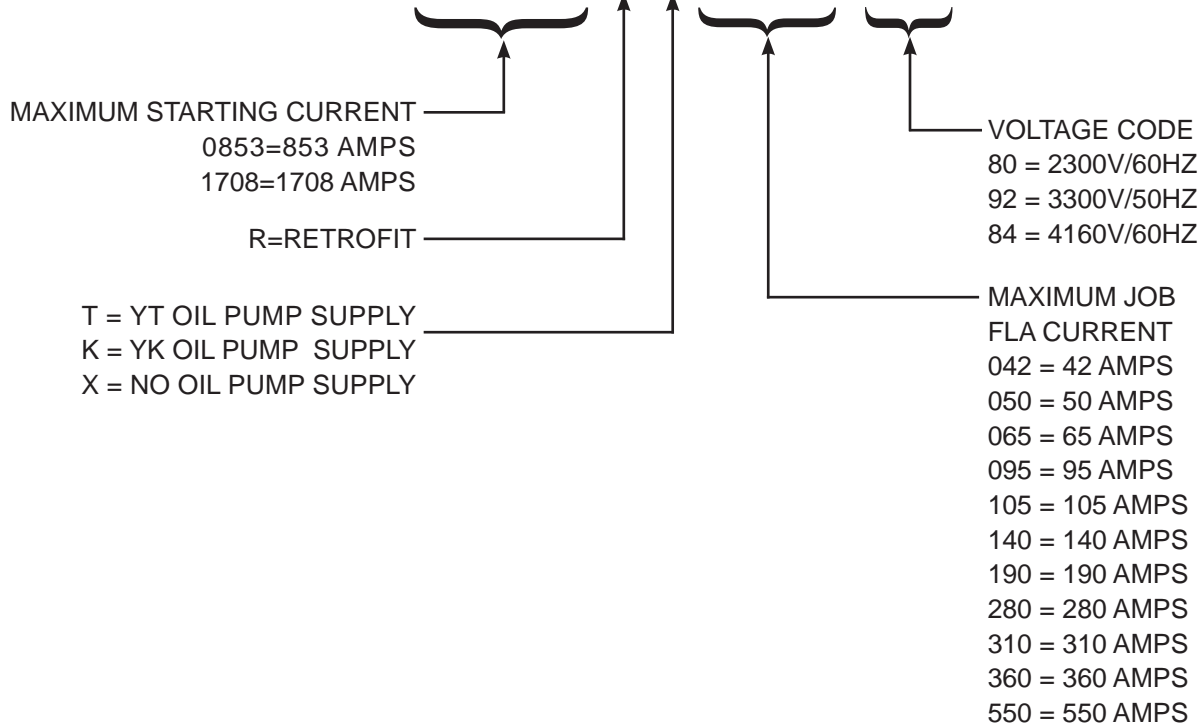

36" CABINET								
UNIT MODEL REFERENCE CHART								
MODEL #	MAX. FLA	MAX. LRA	45% LRA	CT 1, 2, 3	FU 1, 2, 3	POWER STACK ASSEMBLY P/N		
						2300 VAC	3300 VAC	4160 VAC
MVSSS0853R_042-V	42	1896	853	50:5	3R	031-02578-000	031-02578-000	031-02580-000
MVSSS0853R_050-V	50	1896	853	150:5	4R	031-02578-000	031-02578-000	031-02580-000
MVSSS0853R_065-V	65	1896	853	150:5	6R	031-02578-000	031-02578-000	031-02580-000
MVSSS0853R_095-V	95	1896	853	150:5	9R	031-02578-000	031-02578-000	031-02580-000
MVSSS0853R_105-V	105	1896	853	150:5	9R	031-02578-000	031-02578-000	031-02580-000
MVSSS0853R_140-V	140	1896	853	250:5	12R	031-02578-000	031-02578-000	031-02580-000
MVSSS0853R_190-V	190	1896	853	250:5	12R	031-02578-000	031-02578-000	031-02580-000
MVSSS0853R_280-V	280	1896	853	400:5	18R	031-02581-000	031-02581-000	031-02583-000
MVSSS0853R_310-V	310	1896	853	400:5	24R	031-02581-000	031-02581-000	031-02583-000
MVSSS0853R_360-V	360	1896	853	800:5	24R	031-02581-000	031-02581-000	031-02583-000
MVSSS1708R_360-V	360	3796	1708	800:5	24R	031-02581-000	031-02581-000	031-02583-000

72" CABINET								
UNIT MODEL REFERENCE CHART								
MODEL #	MAX. FLA	MAX. LRA	45% LRA	CT 1, 2, 3	FU 1, 2, 3	POWER STACK ASSEMBLY P/N		
						2300 VAC	3300 VAC	4160 VAC
MVSSS1708R_550-V	550	3796	1708	2640:1	36R	031-02581-000	031-02581-000	031-02583-000



FIG. 1 – MEDIUM VOLTAGE SOLID STATE STARTER – FRONT VIEW, EXTERIOR

LD11477

MEDIUM VOLTAGE SOLID STATE STARTER OVERVIEW



Safety is Number One! Voltages present within this starter enclosure may be lethal! Only “qualified” individuals are permitted to service this product!

This instruction describes the operation, start-up, and troubleshooting of the YORK Medium Voltage Solid State Starter (MV-SSS). Qualification in this case requires that the individual hold a certificate, proving satisfactory completion of formal training on proper procedures and safety requirements for working on equipment in the medium voltage (600 VAC to 7500 VAC) class. The qualified individual furthermore is to be knowledgeable of, and adhere to, all safe work practices as required by NEC, OSHA, and NFPA 70E. Because available fault current is determined largely due to sizing of the upstream transformers, wiring, and protective devices - available fault current and arc-flash hazard levels must be determined by personnel responsible for the electrical systems within the facility where this product is installed. Proper personal

protective equipment (PPE) is to be utilized where and when required. This entire publication is to be read thoroughly before servicing this product. Proper lock-out and tag-out procedures are mandatory!



Under no circumstances should any live testing be performed with the main cabinet doors open, exposing medium voltage components! Only the low-voltage access door is permitted to be open during live testing or operation of the unit. The energized safe approach distance for this product is to be determined per NFPA 70E. Non-qualified personnel are not to be present within this boundary during energizing, de-energizing, or energized testing (even with cabinet doors closed) on this starter!

SECTION 1 – THEORY OF OPERATION

General

The Medium Voltage Solid State Starter (MV-SSS), provides a soft continuous current to the chiller motor during motor starting, limiting the inrush of current to a programmed starting value, by reducing the voltage to the motor during startup. This reduced voltage is accomplished when the silicon controlled rectifiers (SCRs) are turned on in a phased back mode during motor acceleration.

The controller board provides turn-on, or “firing”, pulses to the fiber optic transmitter board, which in turn provides firing signals to the SCR power stack assemblies in each phase. Each power stack assembly contains six SCR devices and a gate driver board mounted to the SCR heatsink. Initially during motor starting these firing signals are delayed such that only a portion of the applied AC mains voltage waveform is conducted to the motor. As the motor accelerates and the inrush of current begins to drop, the SCR devices are fired with less delay time so that more of the AC mains voltage is conducted.

Once the motor is up to full speed, there is no longer any delay applied to the firing signals. The SCR devices are turned on fully, and the full applied voltage is conducted to the motor. At this point a shunt contactor is engaged to connect the motor leads directly to the incoming mains voltage so that current no longer passes through the SCR devices.

The SCR power stack assemblies control motor voltage in a manner similar to YORK’s low-voltage air-cooled and liquid-cooled solid state starters, the higher voltage level requires that multiple SCR devices be connected together in series to withstand the voltage. Compared to YORK low-voltage starters which contain 2 SCR devices per phase, the medium voltage starter contains 6 SCRs in each phase at 4160 volts. Therefore, each SCR pair handles just under 1400 volts. This is the maximum safe rating for such SCR devices. Within each phase, three SCRs are fired simultaneously to handle the positive half of the AC waveform, and three more SCRs are fired simultaneously to handle the negative half of the AC waveform.

The gate driver board, which is attached to the SCR power stack assembly, receives firing signals for each of the 6 SCRs from the fiber optic transmitter board. The gate driver board also monitors any fault condition at the SCR power stack, and sends a “status OK” signal back to the fiber optic transmitter board. These fiber optic connections serve to isolate the voltages between phases and provide immunity to electrical noise in the environment.

The fiber optic transmitter board serves only to convert signals between electrical logic and optical logic. With 6 SCR devices per phase, there are 18 firing signals coming from the controller board which are converted to 18 optical signals, or 6 signals to each phase. Also, each of the three gate driver boards sends an optical signal back to the fiber optic transmitter board where these signals are combined into one “fault” signal that is passed from the fiber optic board, back to the controller board.

The controller board’s main function is to provide the firing signals to the SCRs and to control the in-line power contactor and SCR bypass contactor. The controller board also monitors the incoming mains voltage and current to the motor. Decisions about safety and cycling shutdowns are made by logic circuits within the controller board, and all starter parameters, status information, and fault information is communicated back to the YORK OptiView panel through the controller board. This information is passed to the OptiView panel via a Modbus data connection between the Optiview panel and the controller board. In addition, there is a hard-wired start command supplied to the controller board from the OptiView panel, and a hard-wired motor controller shutdown command sent back to the OptiView panel from the controller board.

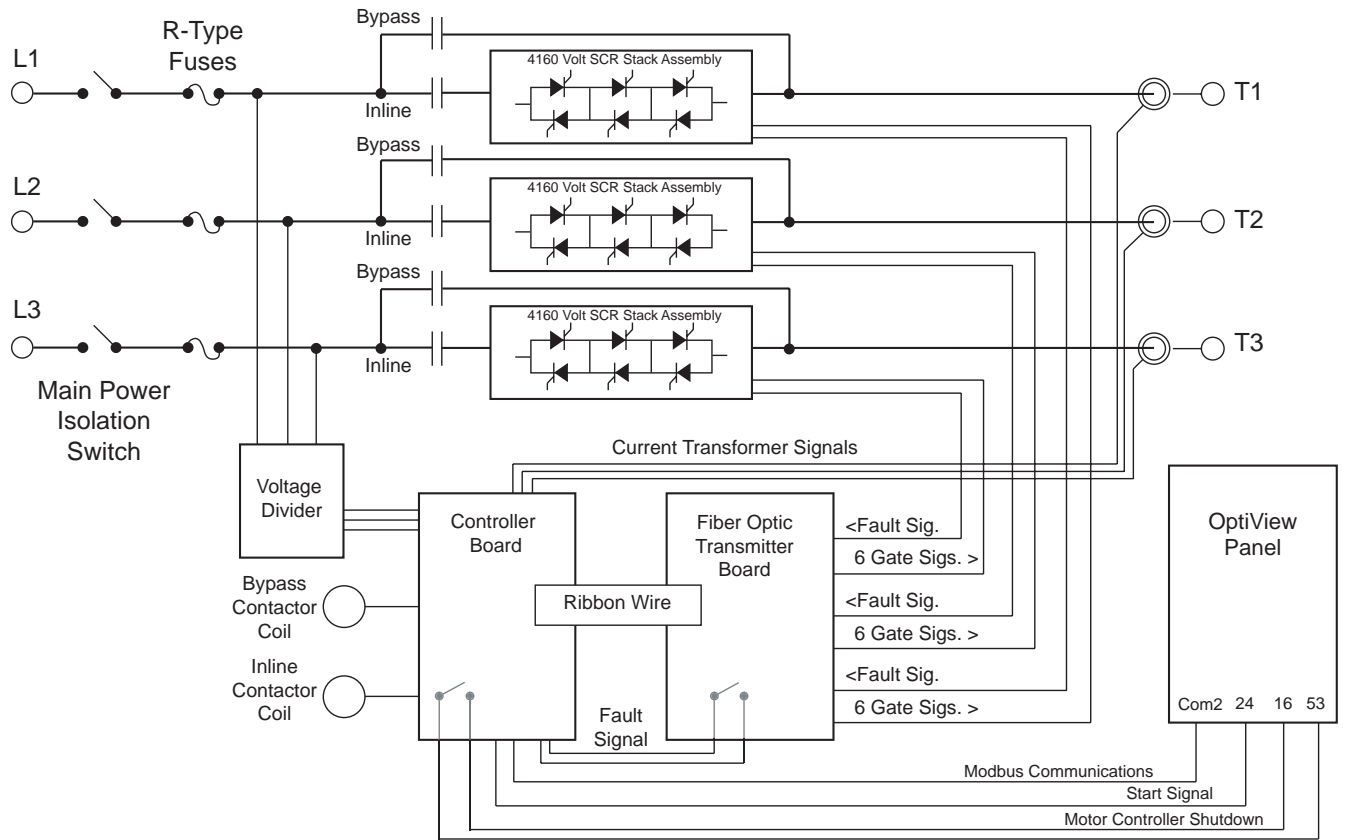

LD11745

FIG. 2 – BASIC BLOCK DIAGRAM

SECTION 2 – SYSTEM ARCHITECTURE

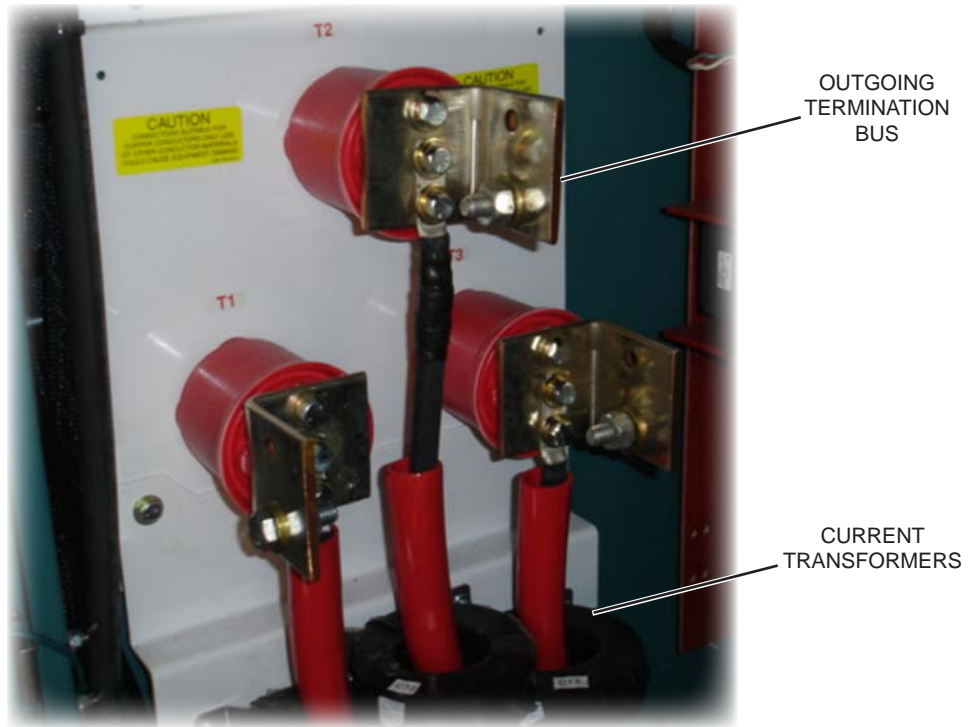

LD11615

FIG. 3 – MOTOR LEAD



LD11616

FIG. 4 – R -TYPE FUSES

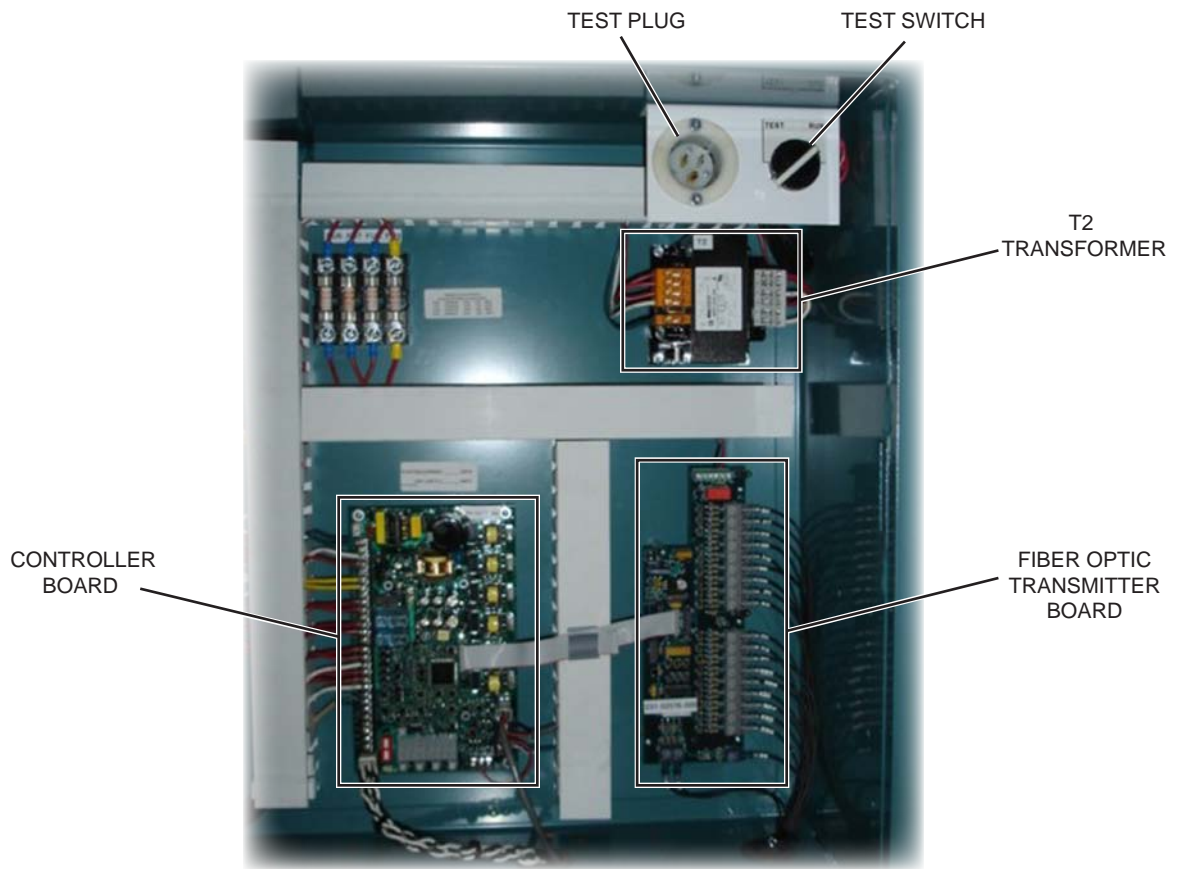

LD11613

FIG. 5 – LOW VOLTAGE COMPARTMENT

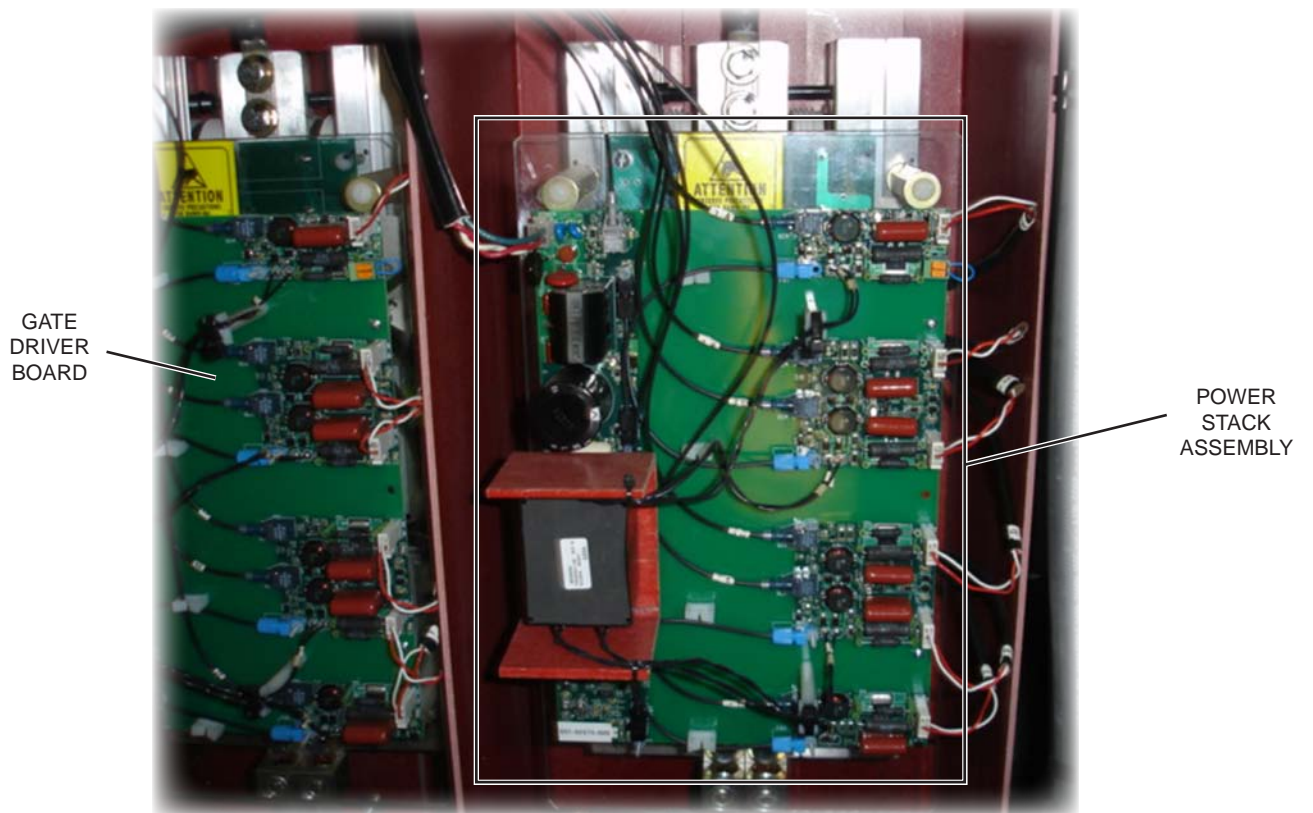

LD11614

FIG. 6 – MEDIUM VOLTAGE COMPARTMENT

GENERAL

The YORK MV-SSS is a floor-standing, air-cooled, self-contained motor starter for 2300, 3300, and 4160 volt 3-phase applications. The cabinet is NEMA 1 rated, and designed for temperatures from 32°F to 104°F (0°C to 40°C), with relative humidity of 20% to 95%, non-condensing. If the MV-SSS is to be applied at greater than 5000' (1524m) it will need to be de-rated. It is designed to interface to the YORK OptiView control panel. All setup parameters are entered through the OptiView panel, and all data and fault information from the starter are communicated back to the OptiView panel for display and access through history screens.

All components of the Medium Voltage Solid State Starter are contained within a standard 36" or 72" wide enclosures (see FIG. 1). This offers a definite advantage over other medium voltage electro-mechanical reduced voltage starters, which typically are in much larger enclosures.

Incoming power connections are made inside the top section of the enclosure to a three-phase load-break rated isolation switch. Main power supply wiring may enter at the top of the cabinet, adjacent to this switch – or may be brought into the cabinet from the floor. Conduit entrance plates are provided at the top and the bottom of the cabinet. There is also a wire path provided along the left cabinet wall for optional bottom-entry wiring. Tie-straps are provided to secure the wires if this option is chosen.

The main incoming power isolation switch is rated to open under load, the number of operations under load is very limited.



Do NOT open this switch as a normal means of shutting down the system.

When the switch is open, all three contact blades should be resting against a grounded metal bracket which assures the load-side circuits are de-energized and discharged. Visual confirmation of an open switch can be made by viewing the contact blades through a Lexan viewing window in the front of the upper cabinet portion of the enclosure (see FIG. 7).



LD11742

FIG. 7 – LEXAN VIEWING WINDOW



Before opening the cabinet of the MV-SSS, standard lock-out/tag-out procedures must be followed, and visual confirmation of an open incoming power switch must be made through the viewing window!

POWER FUSES

From the load side of the incoming power isolation switch, power is routed to the three R-type medium voltage motor-starting power fuses inside the starter (see FIG. 4). These supplied fuses are pre-selected to match the size of motor being applied.



Upstream customer fuses should be sized such that the starter's internal fuses should open first. Most often upstream fuses will be E-type fuses which have a different time/current characteristic compared to R-type fuses.

The time/current characteristics of the upstream fuses must be selected to handle the motor inrush permitted by the R-type fuses. The load side of the MV-SSS motor starting fuses supplies power to the 120 VAC control transformer (T1), the optional 3-phase oil pump transformer (if supplied), the 3-phase voltage divider network, and to the in-line and bypass contactors.

CONTROL TRANSFORMER

The 120 VAC control transformer (T1) is located on the floor of the starter cabinet. It supplies power to the control circuits of the MV-SSS as well as 120 VAC to the OptiView control panel on the chiller. When the three-phase oil pump transformer option is selected, there will be an additional transformer and a set of primary and secondary fuses for line and load sides of this transformer.



LD11743

FIG. 8 – CONTROL TRANSFORMER

3-PHASE VOLTAGE DIVIDER NETWORK

The 3-phase voltage divider network is a series of resistors mounted under the glastic panel that separates the upper and lower sections of the starter cabinet. This series of resistors drops the voltage down to approximately 0.4 VAC to supply a 3-phase representation of line voltage to the MV-SSS controller board.



LD11744

FIG. 9 – 3-PHASE VOLTAGE DIVIDER

CONTACTORS

The in-line and bypass contactors are located directly below the 3 large R-type fuses within the incoming power compartment for the 36" cabinet. The in-line and bypass contactors are located in the starter section of the 72" cabinet. These contactors are vacuum bottle type assemblies, designed to open under load in less than 4 line-cycles. The power from the R-type fuses is supplied to the line side of both vacuum bottle assemblies. The in-line vacuum bottles are engaged initially during motor starting, to supply power to the three SCR assemblies that control the ramping up of voltage to the motor.

Once the motor is up to speed, the bypass contactor closes to connect the motor directly across the incoming line. The in-line contactor can then be dropped out and the SCRs devices turned off. The motor continues to run until the bypass contactor is dropped out.

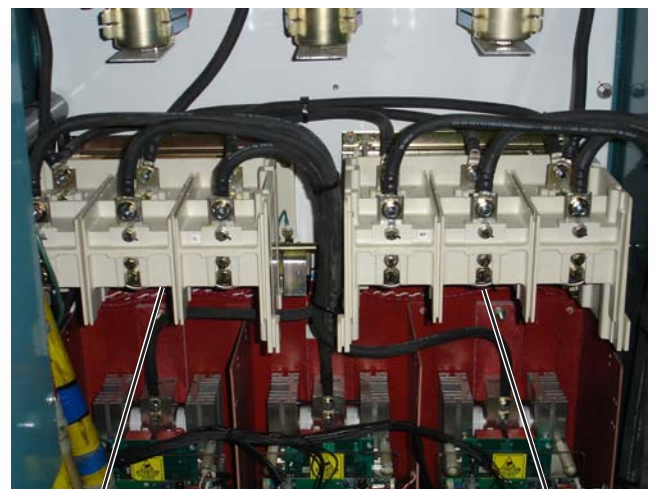
IN-LINE
CONTACTORBYPASS
CONTACTOR

LD11748

FIG. 10 – IN-LINE / BYPASS CONTACTORS

SCR POWER STACK ASSEMBLIES

Wires pass from the load side of the in-line contactor to each of the three phase SCR power stack assemblies. Each stack contains 6 SCR devices, with 3 pairs in series to handle the rated voltage. Each SCR power stack also contains a gate driver board which is powered by 28 VAC and in-turn develops isolated supplies to power the gate of each SCR on the stack assembly. Each individual gate supply on this gate driver board is further isolated by fiber optics which transmit the firing commands from the controller board to the individual SCRs.

The load side of the bypass contactor and the load side of the SCR power stack assemblies are tied together at the output bus connections located along the lower left wall of the starter enclosure. Three copper buses are mounted to glastic standoffs to serve as a point for termination of wiring to the motor. These buses and standoffs are oriented to accept wiring entering the starter cabinet from the top of the enclosure. However, bottom entry is possible. It requires that the mounting of the three buses and standoffs to be rotated 180 degrees and re-bolted to the cabinet structure. For details of motor lead landing pads see the following FIG. below.



FIG. 11 – SCR POWER STACK ASSEMBLIES

LD11614

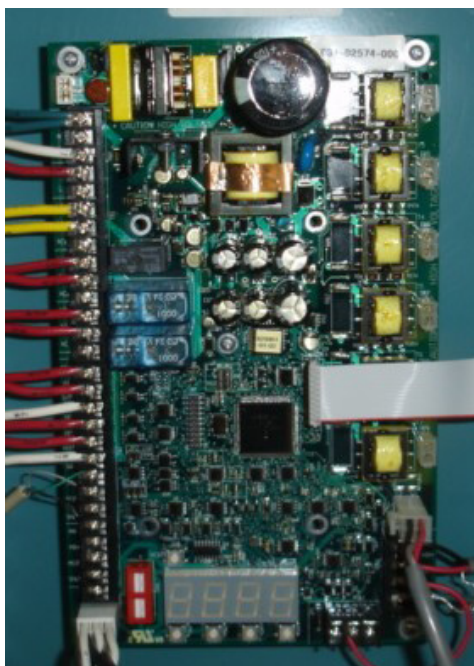
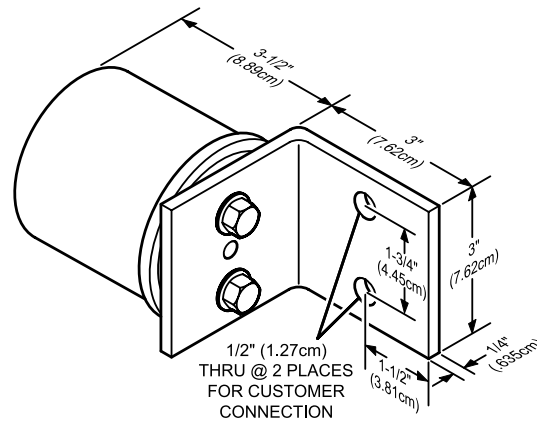
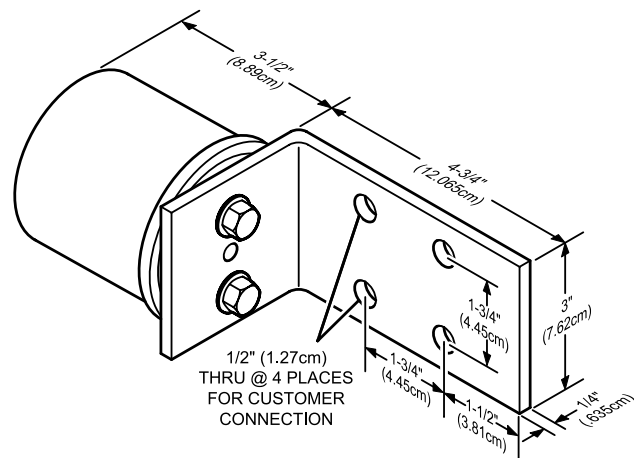

FIG. 12 – CONTROLLER BOARD

LD11746



36" CABINET MOTOR LEAD LANDING PAD



72" CABINET MOTOR LEAD LANDING PAD

LD12114

FIG. 13 – OUTGOING TERMINATION BUS

SECTION 3 – MV-SSS INTERNAL COMPONENTS

CONTROLLER BOARD

The controller board (031-02574-000) is a generic controller board designed for use in various models of high-voltage and low-voltage solid state starters. There are several connectors along the edge of this board that are not used. There are no wires connected to TB0, TB4, TB5, TB6, TB7, TB8, or TB9. The following FIG. depicts the Controller Board (see FIG. 5 for location).

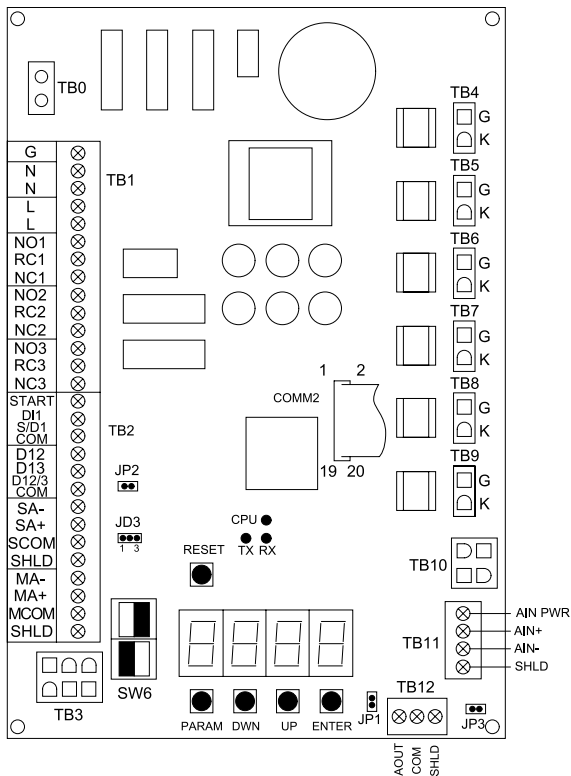

FIG. 14 – CONTROLLER BOARD

LD11747

Controller Board Configuration

JP1 – CLOSED (Jumper installed)

JP2 – OPEN (NO Jumper)

JP3 – OPEN (NO Jumper)

JD3 – OPEN (NO Jumper)

SW6 – per the following table:

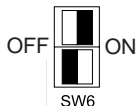
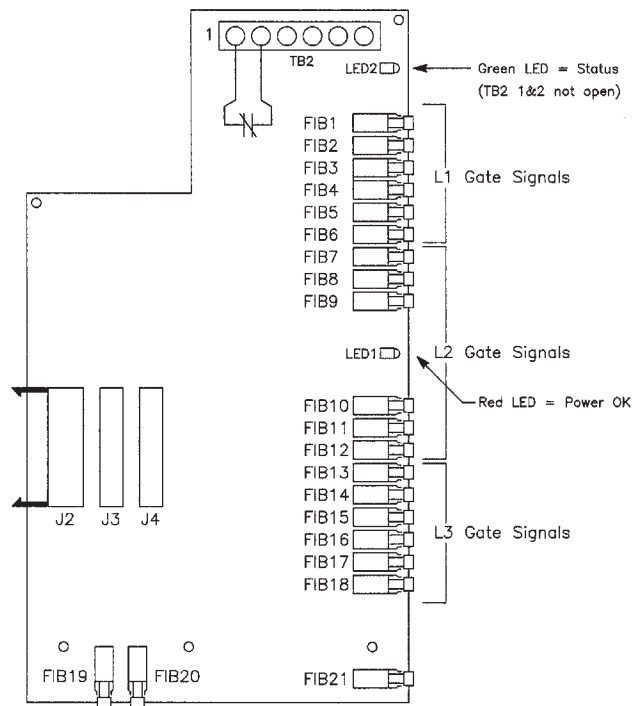

TABLE 1 – CT RATIOS

CT Ratio	Motor FLA	Switch 1	Switch 2
864:1	20A to 24A	OFF	OFF
864:1	25A to 70A	ON	OFF
864:1	71A to 180A	ON	ON
2640:1	40A to 80A	OFF	OFF
2640:1	81A to 200A	ON	OFF
2640:1	201A to 500A	ON	ON

FIBER OPTIC TRANSMITTER BOARD

This board is located adjacent, and to the right of the controller board in the low voltage compartment of the MV-SSS (see FIG. 5 for location). The purpose of this board is to convert electrical digital logic signals to optical digital logic signals. Optical isolation assures there will be no passing of electrical currents between phases, and assures immunity to electrical RFI/EMI noise in the surrounding environment (see the FIG. below).



LD11749

FIG. 15 – FIBER OPTIC TRANSMITTER BOARD

Power to the board and digital logic signals are supplied via a 20 conductor ribbon wire connected to J3 on this board. When power is present on the board, the red “Power OK” LED1 is illuminated. Gate signals to the SCRs are transmitted from connectors FIB1 through FIB18. In addition, each gate driver board sends a fault status back to the fiber optic transmitter board on connectors FIB19, FIB20, and FIB21.

If any one of these signals should indicate a fault at a gate driver, the fiber optic transmitter board extinguishes the green “Status” LED2 on the transmitter board.

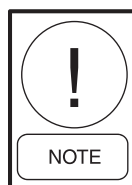

J2, J4, and TB2 pins 3 through 6 are not used in the MV-SSS application.

GATE DRIVER BOARD

Each MV-SSS contains three identical gate driver boards, one for each phase (Refer to the FIG. below).

Gating signals are applied to this board from the fiber optic signals going to connectors SCRA through SCRF. These optical signals in turn cause gate voltages to be applied to the SCR devices at connectors J2, J4, J5, J6, J7, and J8 respectively.

!

J3 is not a gate signal, but connects to a Klixon® thermal detector device on the heatsink.

NOTE

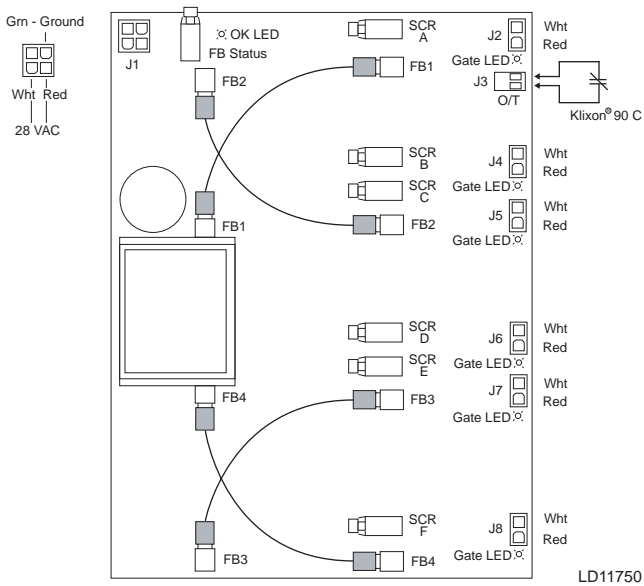

FIG. 16 – GATE DRIVER BOARD

This device opens above 194°F (90°C), and causes loss of the gate driver status "OK" signal back to the fiber optic board. Lack of 28 VAC control power to the gate driver board also can cause loss of the status "OK" signal.

!

There are also gate signal LEDs adjacent to each SCR gate connector.

NOTE

None of these LEDs will be visible when running since we cannot operate the MV-SSS with the cabinet doors open. However the starter has a built in self test mode (BIST) that can be utilized with low voltage (only) applied to the MV-SSS. In the self test mode, gate signals

are sent to all gate driver boards at a very slow rate so that illumination of the gate signal LEDs can be verified. This is addressed in more detail in the troubleshooting section of the service manual.

SCR HEATSINK POWER STACK ASSEMBLY

The SCR devices themselves are very similar to the SCR devices used in YORK low-voltage air-cooled and liquid-cooled solid state starters. The MV-SSS heatsink assemblies or "stacks" are arranged somewhat like having three low voltage SCR heatsinks in series. There are a total of 6 SCRs in each stack, or phase. A gate driver board is attached to each heatsink to develop the gate to cathode potential needed to turn on the gate of each SCR device.

Because it may be somewhat confusing to see how electrical current flows in such an assembly the FIG. below shows conventional current flow, alternating in both directions.

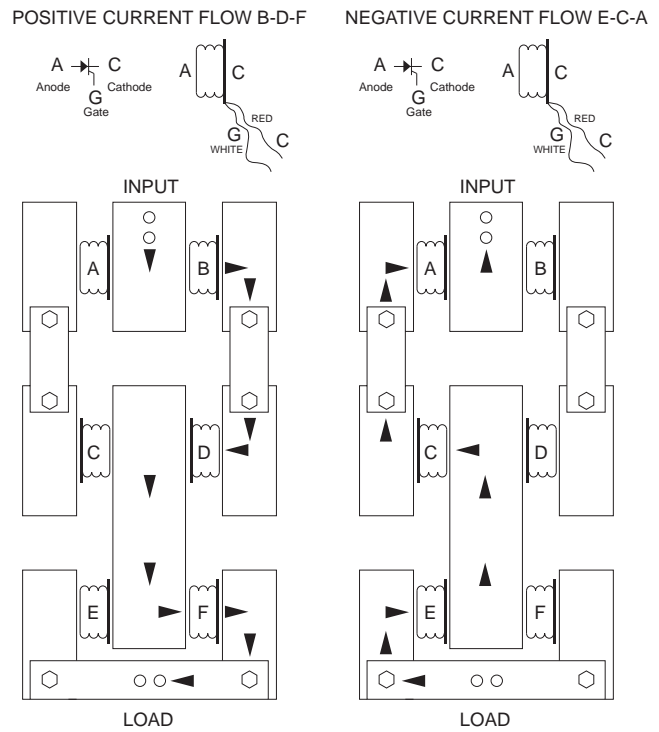
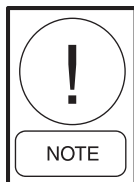

FIG. 17 – SCR HEATSINK POWER STACK CURRENT FLOW

VOLTAGE DIVIDER BOARD

The voltage divider board takes the incoming line voltage and drops it down to a lower voltage that can be supplied to the controller board for the purpose of monitoring the incoming line voltage and for detecting phase loss conditions, sags, etc.



If the wires from the divider board are unplugged from TB10 on the controller board, the controller board's internal resistors are no longer in the circuit and the voltage at the wires on this plug will increase to much more than the normal 0.4 VAC that is supplied to the controller board.

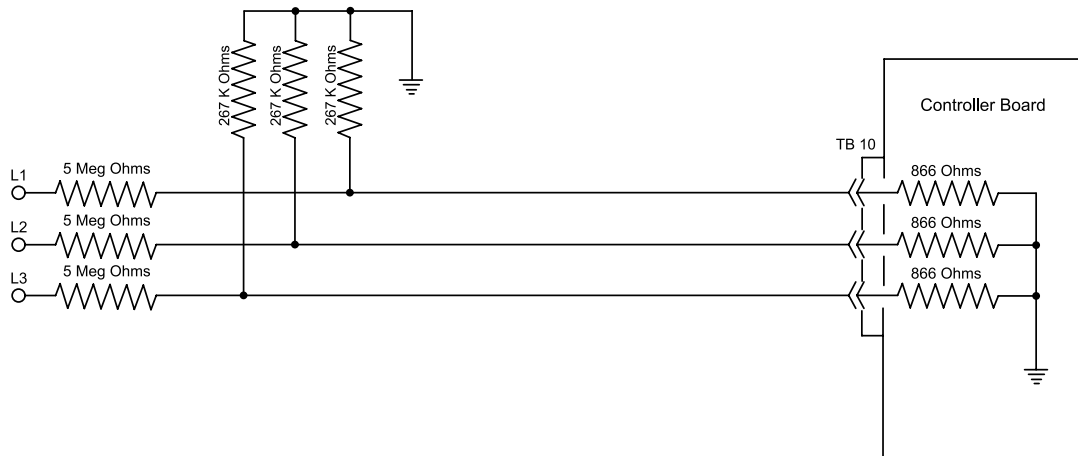

LD11777

FIG. 18 – DIVIDER / CONTROLLER RESISTORS

SECTION 4 – INSTALLATION

INSPECTION

Remove any transit packing and inspect the unit to ensure that all components have been delivered and that no damage has occurred during transit. If any damage is evident, it should be noted on the carrier's freight bill and a claim entered. Any major damage must be reported to your local YORK representative.

GENERAL

Before installing the starter, ensure:

- The starter is the correct voltage and current rating for the motor being started.
- All of the installation safety precautions are followed.
- The correct power source is available.
- The installation site meets all environmental specifications for NEMA 1.
- The chiller being started is ready to be started.
- Any power factor correction capacitors (PFCCs) if installed, are located on the power source side of the starter and not on the motor side.
- Ensure that the starter is positioned so that the cabinet door has ample clearance, and all of the controls are accessible.



Failure to remove power factor correction or surge capacitors from the load side of the starter will result in serious damage to the starter which will NOT be covered by the starter's warranty. The capacitors must be powered from the line side of the starter. An auxiliary contact can be used to energize the capacitors after the motor has reached full speed.

SAFETY PRECAUTIONS

To ensure the safety of the individuals installing the starter, and the safe operation of the starter, observe the following guidelines:

- Ensure that the installation site meets all of the required environmental conditions.
- **LOCK-OUT/TAG-OUT ALL SOURCES OF POWER!**

- Follow all NEC (National Electrical Code) and/or C.S.A. (Canadian Standards Association) standards.
- Remove any foreign objects from the interior of the enclosure.
- Ensure that wiring is installed properly by a qualified electrician.
- Ensure that the individuals installing the starter have proper personal protective equipment (PPE).

STARTER LOCATION

The standard YORK MV-SSS is intended for indoor installations only. The cabinet is NEMA 1 rated. You should allow for 6" of clearance on either side of the starter and across the back of the starter enclosure. Ensure that the starter is positioned so that the cabinet door(s) has ample clearance, and all of the controls are accessible (36" minimum). There should be 24" of clearance above the starter cabinet (see FIG. 21 & 22). If the 3 phase Oil Pump Transformer option is selected please allow for an additional 24" of clearance above the Transformer.

The temperature range for operation is 32° F to 104°F (0°C to 40°C), with humidity not to exceed 95%, non-condensing. If the location is such that moisture could be permitted to condense on components inside the MV-SSS, it will be necessary to add cabinet heaters to keep the moisture out. Failure to prevent condensation inside the starter cabinet could result in serious electrical failure which is NOT covered by warranty. In cases where the application is greater than 5000' (1524m) above sea level, the starter will need to be de-rated. For additional details about de-rating the unit contact YORK marketing.

ELECTRICAL CONNECTION

The following connection recommendations are intended to ensure safe and satisfactory operation of the unit.



Failure to follow the recommendations could cause harm to persons, or damage to the unit, and may invalidate the warranty.



No additional controls (relays, etc.) should be mounted in the unit. Power and control wiring not connected to the unit should not be run through the unit. If these precautions are not followed electrical noise could cause malfunctions or damage the unit and its controls.

CONTROL WIRING

Wiring between the MV-SSS and the YORK OptiView control panel consists of 6 conductors plus a shielded communications cable. The 6 conductors are for the following:

- GND – Ground
- L – 120 VAC control power hot side
- 2 – 120 VAC control power neutral side
- 24 – Start signal from panel to MV-SSS
- 16 – Motor controller fault signal from MV-SSS contact back to control panel.
- 53 – Motor controller 120 VAC supply to dry contact in the MV-SSS

In addition, the modbus cable is comprised of three conductors plus a shield. Standard 18 gauge shielded wire may be used. The following FIG. relates the modbus connections between the MV-SSS and the OptiView Panel.

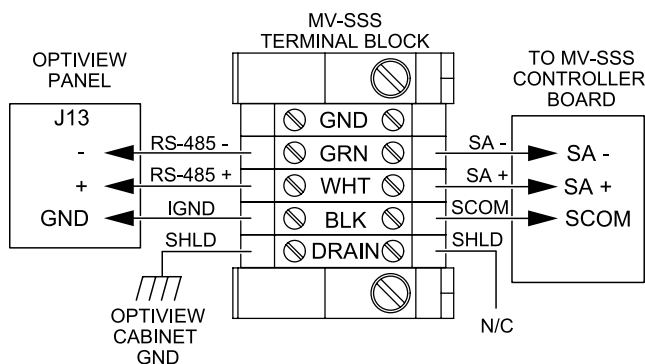

FIG. 19 – MODBUS CONNECTIONS

LD12113



Control wiring is NOT to be run in the same conduit with power wiring.

POWER WIRING

Incoming power wiring terminals are designated L1, L2, and L3, and output power wiring terminals are designated T1, T2, and T3. Do NOT run input and output wiring in the same conduit. Connection cables must be of the correct current rating per NEC/CSA.

Input and output wiring connections are NEMA 2, which consists of two 1/2" holes per phase, spaced 1-3/4" apart. The contractor will need to provide crimped lugs on the ends of the wires to match the 1/2" bolt holes provided. FIG. 20 below shows the details for the incoming power, refer to FIG. 13 for motor lead details.

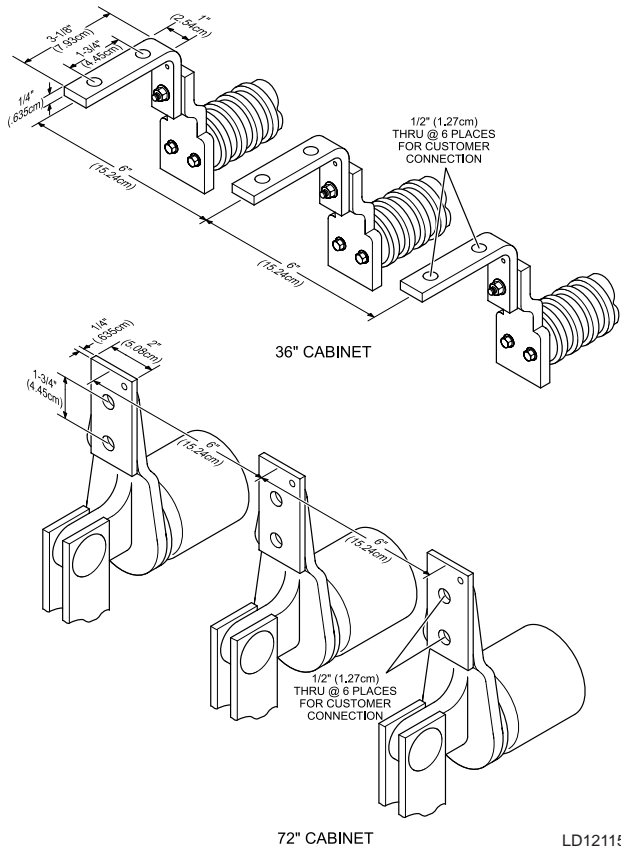

FIG. 20 – INCOMING POWER LANDING PAD

LD12115

OIL PUMP WIRING (OPTIONAL)

Optional field wiring terminals are designated 101, 102, 103, and GND. Standard 14 gauge wire may be used. The following FIG. shows the connections for the Oil Pump. Refer to 160.00-RP4 Low Voltage Compartment for TB location.

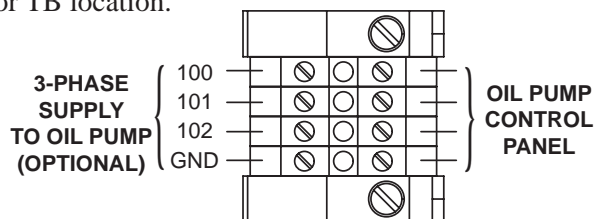
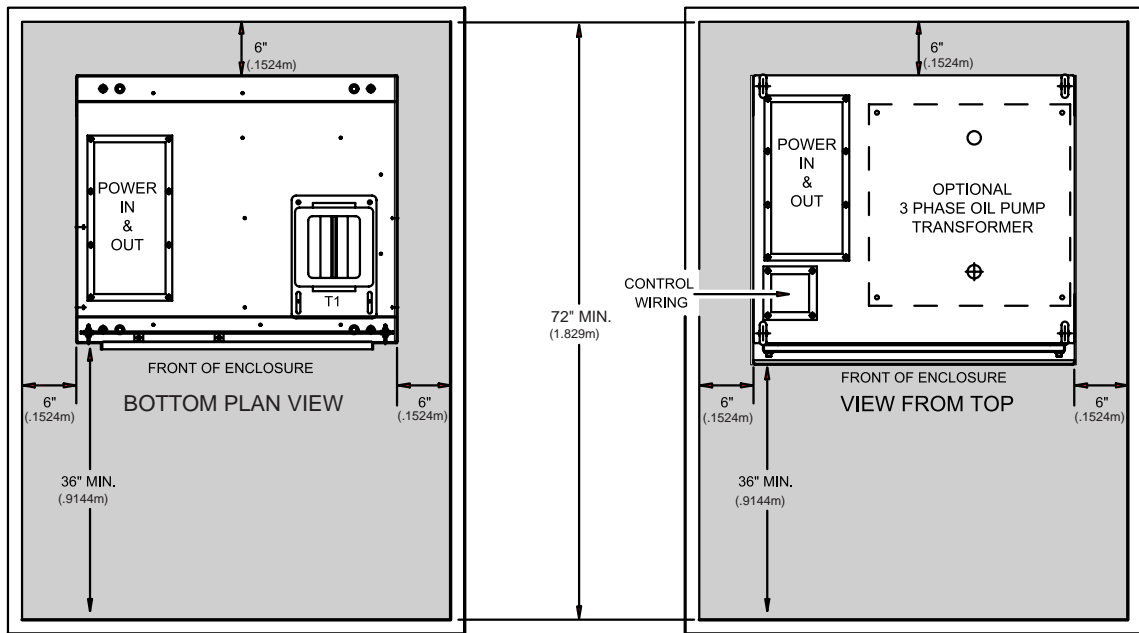

FIG. 21 – OIL PUMP WIRING

LD12163



36" CABINET
BOTTOM ENTRY

36" CABINET
TOP ENTRY

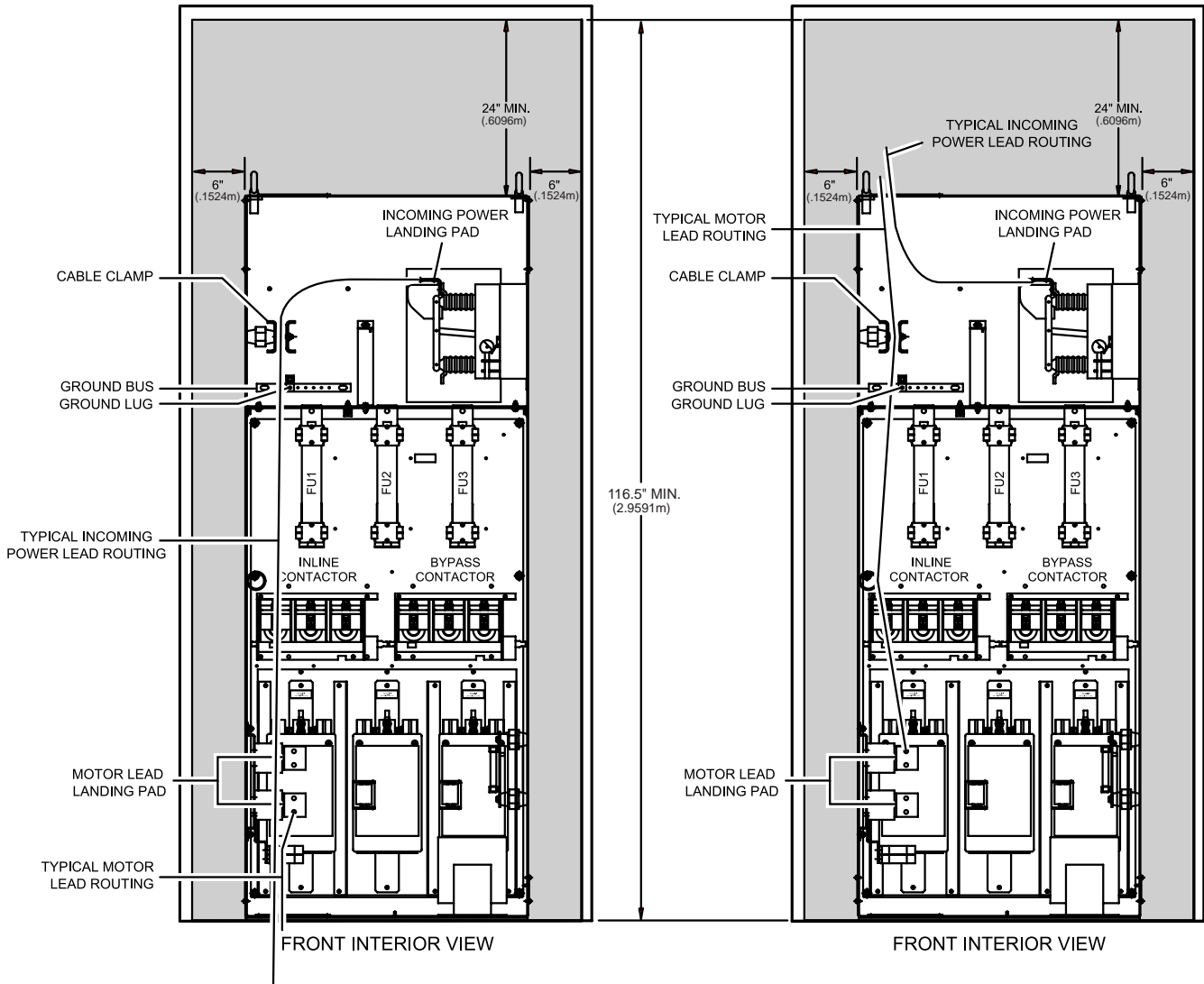

FRONT INTERIOR VIEW

FRONT INTERIOR VIEW

LD12116

FIG. 22 – 36" CABINET ELECTRICAL CONNECTIONS / UNIT CLEARANCES

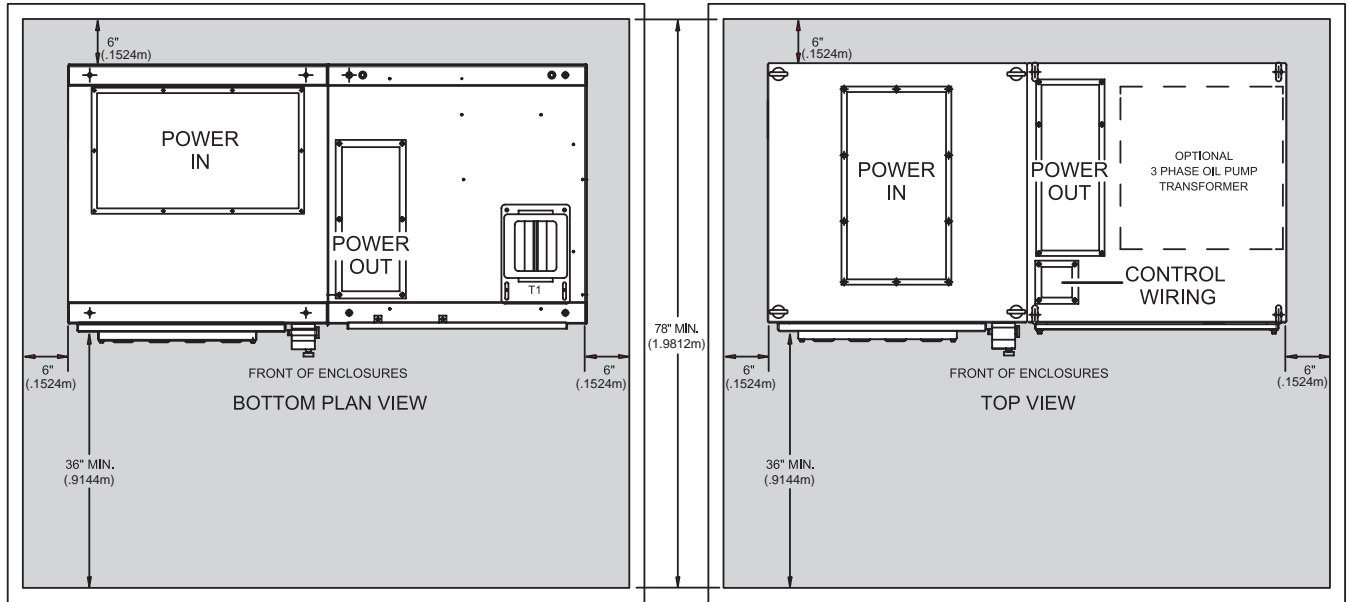

72" CABINET
BOTTOM ENTRY

72" CABINET
TOP ENTRY

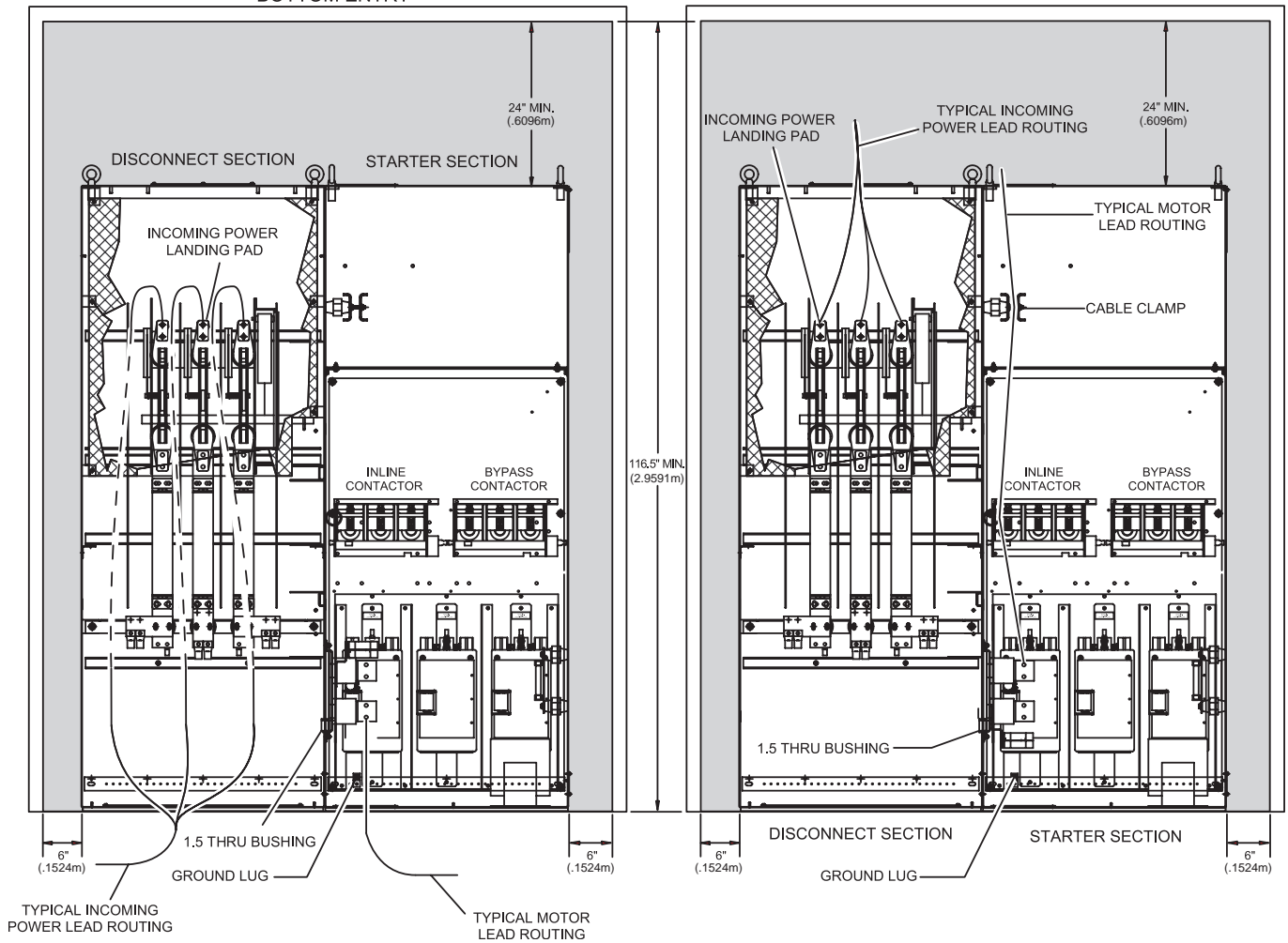
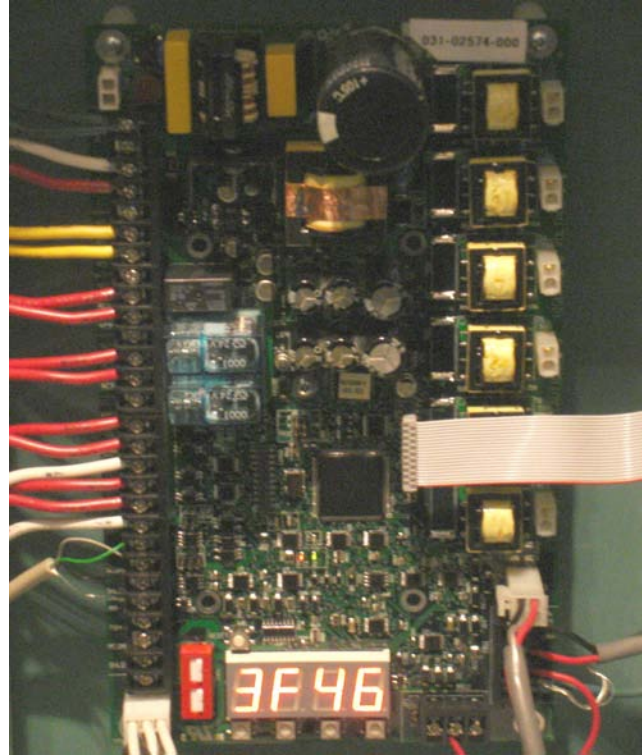

FIG. 23 – 72" CABINET ELECTRICAL CONNECTIONS / UNIT CLEARANCES

SECTION 5 – STARTER FAULTS

The Medium Voltage Solid State Starter (MV-SSS) controller board, in addition to generating firing pulses for the SCRs, also continually checks status of the three power stack assemblies, monitors for system parameters such as overcurrent and undervoltage, and communicates status and data back to the YORK OptiView panel for display and annunciation. Decisions about starter faults are made at the MV-SSS controller board. In the event of a problem, the MV-SSS controller opens the motor controller contacts which cause 120 VAC to drop out on wire #16 going back to the OptiView. At the same time, the controller board sends a fault message to the OptiView via the modbus connection.

There are many individual MV-SSS faults that can be detected. Some of these are combined together into a single generic OptiView panel message. The list below shows all the possible MV-SSS faults, and the associated OptiView panel message that is generated. The individual MV-SSS fault is also displayed on the controller board inside the low-voltage section of the MV-SSS cabinet (see FIG. 23). The MV-SSS controller board will display “F_XX”, where XX is a two-digit value representing the MV-SSS fault.



LD11907

FIG. 24 – CONTROLLER BOARD FAULT MESSAGE

TABLE 2 – FAULT MESSAGES

OPTIVIEW PANEL MESSAGE	MV-SSS CONTROL- LER BOARD DISPLAY	MV-SSS FAULT DESCRIPTION
MV-SSS - 105% Overload	31	Overcurrent, motor current exceeded 105% FLA for 40 seconds.
MV-SSS - Contactor Fault	48	Bypass Contactor Fault, aux. contacts do NOT match contactor status.
	49	In-line Contactor Fault, aux. contacts do NOT match contactor status.
MV-SSS - Control Board	51	Current Sensor Offset, an abnormal current is detected at power up.
	52	Burden Switch was changed while the motor was running.
	94	Illegal Software State, program error detected on the controller board.
	95	Parameter Storage Loss, values in memory are invalid at power up.
	96	Illegal Instruction Trap, a program instruction error occurred on the controller board.
	97	Software Watchdog, the program has gotten off path and is NOT running properly.
	98	Spurious Interrupt, an interrupt has occurred that is NOT normally utilized by the program.
99	Program Storage Fault, the checksum test failed at power up.	

TABLE 2 – FAULT MESSAGES (CON'T)

OPTIVIEW PANEL MESSAGE	MV-SSS CONTROLLER BOARD DISPLAY	MV-SSS FAULT DESCRIPTION
MV-SSS - Disconnect Fault	46	Disconnect Open, feedback indicates the switch is opened while running.
MV-SSS - Failed SCR	40	An Open or Shorted SCR has been detected.
MV-SSS - Ground Fault	38	Ground Fault current exceeds 50% FLA for 3 seconds.
MV-SSS - Heatsink High Temperature - Running	71	Stack Overtemperature Running, the temperature exceeded 194°F (90°C) while running. A Klixon® device on one of the 3 stacks has opened its circuit.
MV-SSS - Heatsink High Temperature - Stopped	72	Stack Overtemperature Stopped, the temperature exceeded 194°F (90°C) while stopped. A Klixon® device on one of the 3 stacks has opened its circuit.
MV-SSS - High Supply Line Voltage	24	High Line L1 to L2, greater than 13.2% above rated for 20 seconds.
	25	High Line L2 to L3, greater than 13.2% above rated for 20 seconds.
	26	High Line L3 to L1, greater than 13.2% above rated for 20 seconds.
MV-SSS - High Instantaneous Current	30	A single sample of motor current was higher than the maximum amps for the starter.
	32	Current exceeded 115% of maximum programmed inrush for 1 second.
MV-SSS - Logic Board Power Supply	50	Control Power is Low, as determined at the Controller board.
MV-SSS - Low Supply Line Voltage	21	Low Line L1 to L2, less than 19% below rated for 20 seconds.
	22	Low Line L2 to L3, less than 19% below rated for 20 seconds.
	23	Low Line L3 to L1, less than 19% below rated for 20 seconds.
MV-SSS - Motor or Starter Current Imbalance	37	Current Imbalance, greater than 30% difference between phases for 45 seconds. This fault is inhibited for the first 45 seconds, and when motor current is below 80% FLA.
MV-SSS - Phase Loss	27	Phase Loss, a single phase dropped more than 30% below the rated value.
	28	No Line Voltage detected at Voltage Divider input to TB10.
MV-SSS - Phase Rotation	10	The incoming phase rotation is not ABC.
MV-SSS - Power Fault	34	Undercurrent, one of the phases has dropped below 10% FLA for 2 cycles.
	39	Motor Current dropped to below 25% FLA for 1/2 second while running.
MV-SSS - Run Signal	68	Run Interlock, both hard-wired and serial run commands were NOT present within 5 seconds.
MV-SSS - Serial Communications	82	Network Timeout, no modbus communications for more than 60 seconds.
(NOT reported on OptiView panel)	54	BIST Abnormal Exit - BIST was exited before completing all tests.

DETAILED EXPLANATION OF MV-SSS CONTROLLER BOARD – IN NUMERIC ORDER

10 – Phasing NOT ABC – The incoming phase rotation is sensed by the three signals derived from the voltage divider and applied to the Controller board at connector TB10.

21 - Low Supply Line L1 to L2 – The incoming line voltage has dropped below the threshold as detected at the signal applied to the Controller board at TB10. The threshold is as follows:

4160 Volt Starters – 3370 VAC
3300 Volt Starters – 2673 VAC
2300 Volt Starters – 1863 VAC

22 – Low Supply Line L2 to L3 – The same as above for L1 to L2.

23 – Low Supply Line L3 to L1 – The same as above for L1 to L2.

24 – High Supply Line L1 to L2 – The incoming line voltage has exceeded the threshold as detected at the signal applied to the Controller board at TB10. The threshold is as follows:

4160 Volt Starters – 4713 VAC
3300 Volt Starters – 3739 VAC
2300 Volt Starters – 2606 VAC

25 – High Supply Line L2 to L3 – The same as above for L1 to L2.

26 – High Supply Line L3 to L1 – The same as above for L1 to L2.

27 – Phase Loss – A single-cycle phase loss is detected on any individual phase as detected at TB10. To be detected, the line-to-line voltage must drop to below 30% of the nominal value. This fault only occurs when the motor is running, it is ignored when the motor is stopped.

28 – No Line Voltage – This fault occurs when the starter receives a command to start, but no line voltage is detected at TB10.

30 – Instantaneous Overcurrent – The starter has detected a single sample of motor current which is in excess of the starter's maximum rating.

31 – 105% Overcurrent – The motor current has exceeded 105% of full-load amps (FLA) for 40 seconds.

32 – High Short Term Current – The motor current has exceeded 115% of the programmed inrush current for 1 second.

34 – Undercurrent – One or more phases of motor current has dropped below 10% of FLA for 2 line-cycles. This fault is inhibited for the first 4 seconds of starting, and until all phase currents have reached 25% FLA.

38 – Ground Fault – The ground fault current has been determined to have exceeded 50% of motor FLA for 3 seconds. There is no device measuring current to ground. This is done by looking at all three motor currents, and calculating the instantaneous sum of all three. Recognize that at any given time, the current passing in the direction toward the motor must equal any currents coming back from the motor in the other phases. The net sum of all three instantaneous currents (with attention to polarity) is always zero. If at any time the sum is not zero, this would indicate that some current passing toward the load is not returning to the starter, but is leaking off to ground.

39 – No Current at Run – This fault occurs if the motor current is less than 25% FLA for ½ a second.

40 – Failed SCR – This fault indicates an open or shorted SCR has been detected. The controller board looks at line voltage and motor current, and determines if an SCR is open or shorted based on analysis of the voltage and current waveforms and knowing what SCR device should be turned on at any given time. The controller does not indicate which SCR was detected to have a problem. It is necessary to check the devices with an ohmmeter and/or gate/hi-pot tester. Refer to form 160.00-M5 for additional information.

46 – Disconnect Open – There is a micro-switch mounted on a cam attached to the main power disconnect or isolation switch. This micro-switch advises the controller board of the status of this isolation switch. If this switch provides indication that the main power disconnect was opened while the motor was running, this fault will be generated.

48 – Bypass Fault – The bypass vacuum contactor has an auxiliary switch mounted on it and wired back to the controller board at DI1. The controller board also controls the status of the bypass vacuum contactor through an output from R3 on this board. If this switch status does not match the status of R3, this fault is generated.

49 - In-line Fault – The in-line vacuum contactor has an auxiliary switch mounted on it and wired back to the controller board at DI2. The controller board also controls the status of the bypass vacuum contactor through an output from R2 on this board. If this switch status does not match the status of R2, this fault is generated.

50 – Control Power Low – This fault is generated when the 120 VAC control power drops below 90 VAC.

51 – Current Offset Sensor – The controller board performs a diagnostic at power up which checks the current feedback circuits on the controller board. If this test fails, this message is generated.

52 – Burden Switch Error – This fault occurs if the CT SW6 switch on the controller board is changed while the motor is running. Changing the switch while running can cause damage to the controller board.

54 – BIST Abnormal Exit – This fault occurs if the BIST routine is stopped before it is able to complete all of the BIST tests. This can be caused by the disconnect closing, line voltage being detected, or current being detected.

68 – Run Interlock – As with other YORK products, the MV-SSS requires both a hard-wired start command and a serial communications run command. If both are not received within 5 seconds, this message is generated.

71 – Stack Overtemperature Running – One of the Klixon® thermal switches has opened on one of the heatsinks while the chiller motor is running.

72 - Stack Overtemperature Stopped – One of the Klixon® thermal switches has opened on one of the heatsinks while the chiller motor is stopped.

82 – Network Timeout – This fault occurs if the MV-SSS controller board does not receive a modbus communication from the OptiView panel for more than 60 seconds.

94 – Illegal Software State – This fault occurs if the controller board determines that the software has performed an unexpected operation.

95 – Parameter Storage Loss – During power up the controller board checks all values stored in memory and if any are determined to be invalid, this message is generated. This can occur at times when software versions are changed, and values from the old software are left in memory locations that are no longer used by the new software. If this should occur, hold the “Param” and “Enter” keys down together while applying power to the board. This will clear out the memory.

96 – Illegal Instruction Trap – This fault occurs if the controller board determines the software has performed an instruction that is not part of the normal program.

97 – Software Watchdog – The software program performs tasks in sequence, and after all tasks are performed, the program goes back to the first instruction and begins over again. One of the programmed tasks is to essentially “touch base”. If the software does NOT “touch base” before going off to follow the list of tasks once again, it generates this fault. This assures that the software program continues to run the program over and over. If the program becomes locked up or if it should get side-tracked, it fails to “touch base” and the controller board shuts down on this fault.

98 – Spurious Interrupt – The controller board has detected an interrupt that was not generated by the program.

99 – Program Storage Fault - The checksum test failed at power up. Check to see that the proper program is loaded to the controller board.

SECTION 6 – TROUBLESHOOTING

TABLE 3 – GENERAL TROUBLESHOOTING

MOTOR WILL NOT START, NO OUTPUT TO MOTOR.

STATUS	CAUSE	SOLUTION
Fault Displayed	Shown on Display	See Fault Code table
Watchdog LED is ON	CPU card problem	Consult factory
Display is blank	Control voltage is absent	Check for proper control voltages
	Ribbon cables	Check ribbon cables
Stopped	Control devices	Check control devices
No line	Missing at least 1 phase of main power.	Check Power system.

MOTOR ROTATES BUT DOES NOT REACH FULL SPEED.

STATUS	CAUSE	SOLUTION
Fault displayed	Shown on display	See Fault Code table
Accel	Mechanical Problems	Check for load binding / Check Motor
	Inadequate start limit settings	Increase start current setting
	Abnormally low line voltage	Fix line voltage problems
Running	Mechanical Problems	Check for load binding / Check Motor
	Inadequate overload limit settings	Increase overload current setting
	Abnormally low line voltage	Fix line voltage problems

MOTOR STOPS WHILE RUNNING.

STATUS	CAUSE	SOLUTION
Fault displayed	Shown on display	See Fault Code table
Display is blank	Control voltage is absent	Check control wiring and voltage
Stopped	Control devices	Check control system

OTHER SITUATIONS.

STATUS	CAUSE	SOLUTION
Power metering not working, or incorrect display on OptiView.	CT installed wrong	Fix CT installation. White dot to line side.
Motor current or voltage display on OptiView fluctuates with steady load.	Motor	Verify motor is running smoothly without variation on speed or load.
	Power connection	Shut off all power and check connections.
	SCR Fault	Check SCR devices, Gate Drivers, and outputs from Fiber Optic Transmitter Board
Erratic Operation	Loose connections	Shut off all power and check connections.
Accelerates too quickly	Maximum start current setting	Decrease Maximum start current setting.
	Improper FLA setting	Check FLA setting.
Accelerates too slowly	Maximum start current setting	Increase Maximum start current setting.
	Improper FLA setting	Check FLA setting.
Motor short circuit	Wiring fault	Identify fault and correct.
	Power factor correction capacitors (PFCC) on starter output	Move PFCC to line side of starter.



BY JOHNSON CONTROLS

P.O. Box 1592, York, Pennsylvania USA 17405-1592
Copyright © by JOHNSON CONTROLS, INC. 2008
Form 160.00-05 (1108)
Supersedes 160.00-05 (706)

(717) 771-7890
www.york.com

Subject to change without notice. Printed in USA
ALL RIGHTS RESERVED