

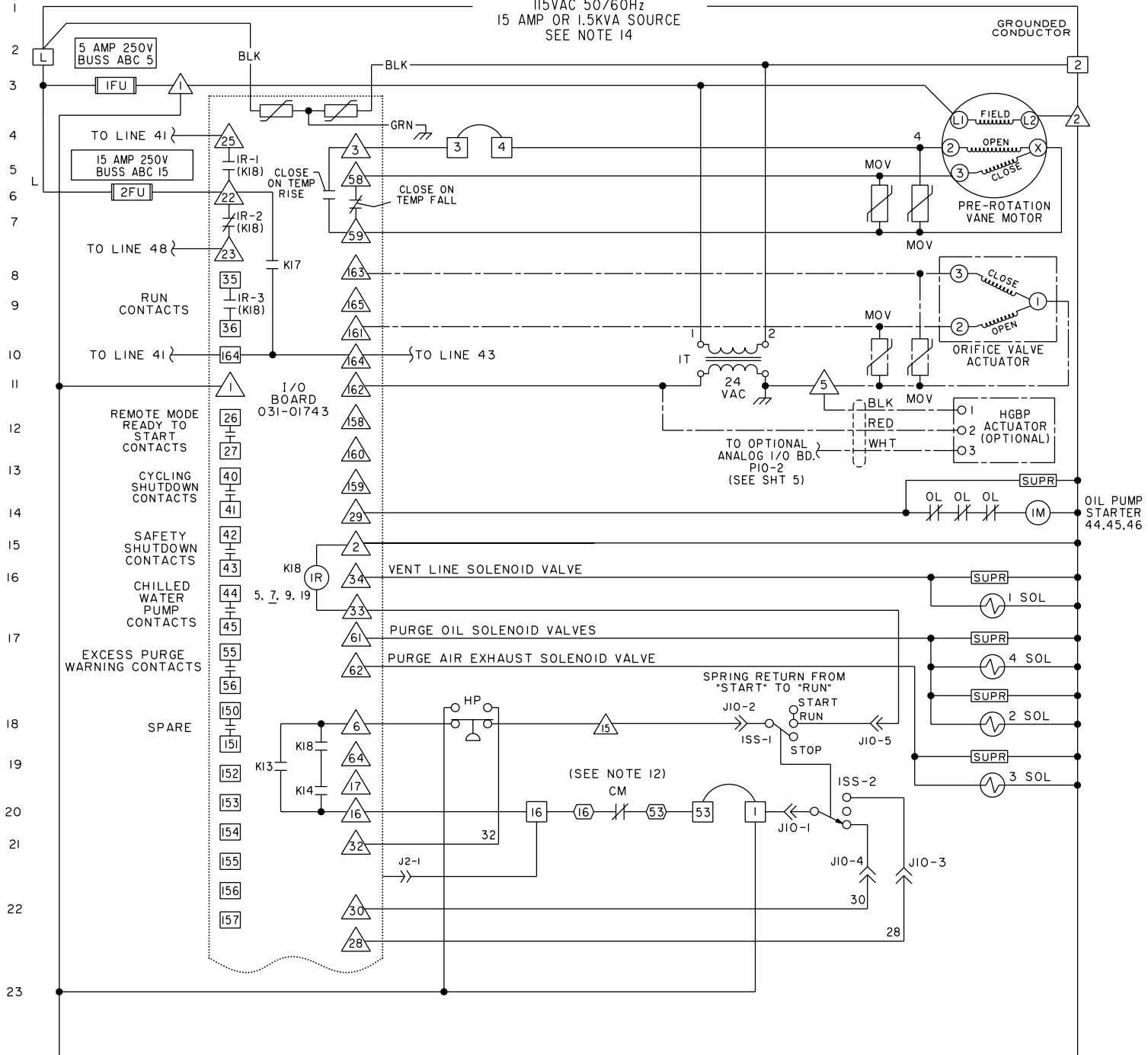

# ELEMENTARY DIAGRAM

CONTROL SUPPLY  
115VAC 50/60Hz  
15 AMP OR 1.5KVA SOURCE  
SEE NOTE 14

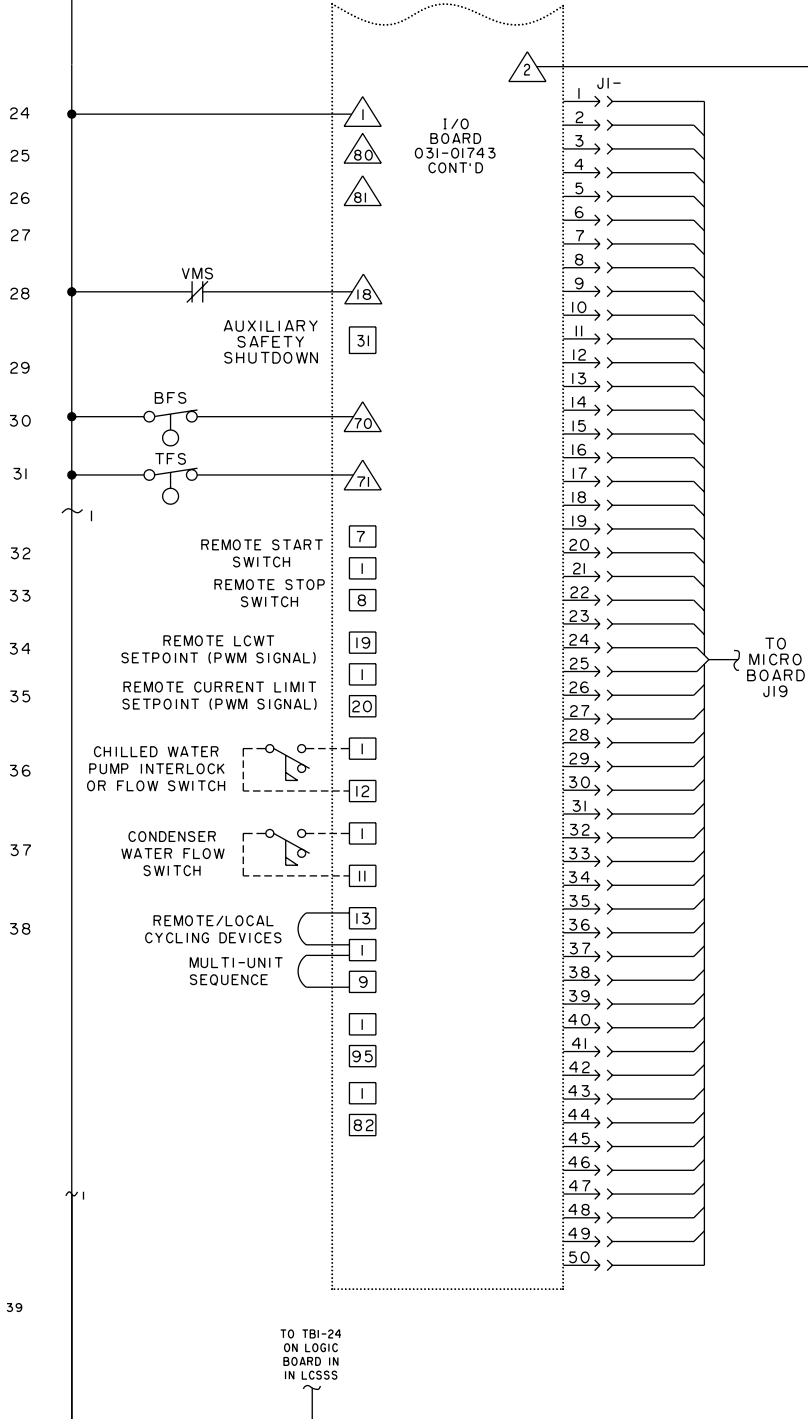



COMPRESSOR MOTOR SUPPLY VOLTAGE RANGE - (V)	LOW LINE VOLTAGE OPERATING POINT		HIGH LINE VOLTAGE OPERATING POINT	
	CUTOUT - (V) (ON FALL)	CUTIN - (V) (ON RISE)	CUTOUT - (V) (ON RISE)	CUTIN - (V) (ON FALL)
200-208	160	174	227	226
220-240	185	200	262	261
380	305	331	415	414
400	320	349	436	435
415	335	362	454	453
440-480	370	400	524	523
550-600	460	502	655	654
SUPPLY VOLTAGE RANGE DISABLED	NONE	0	NONE	0

40  
41  
42  
43  
44  
45  
46  
47  
48  
49  
50  
51  
52

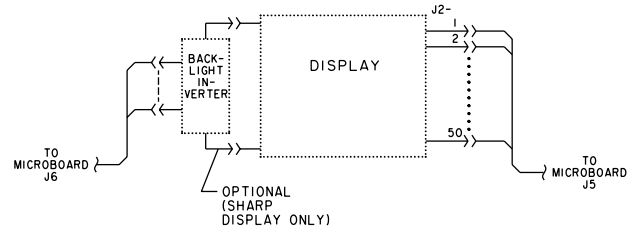
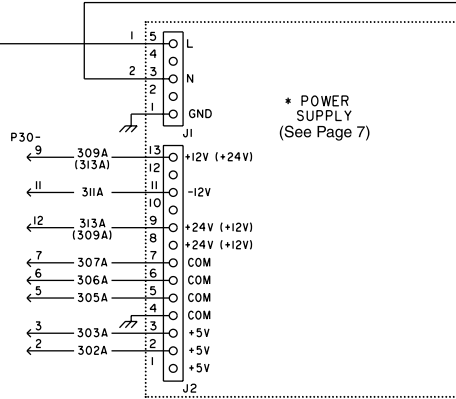
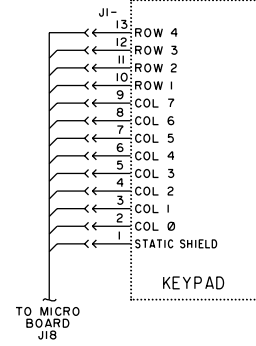
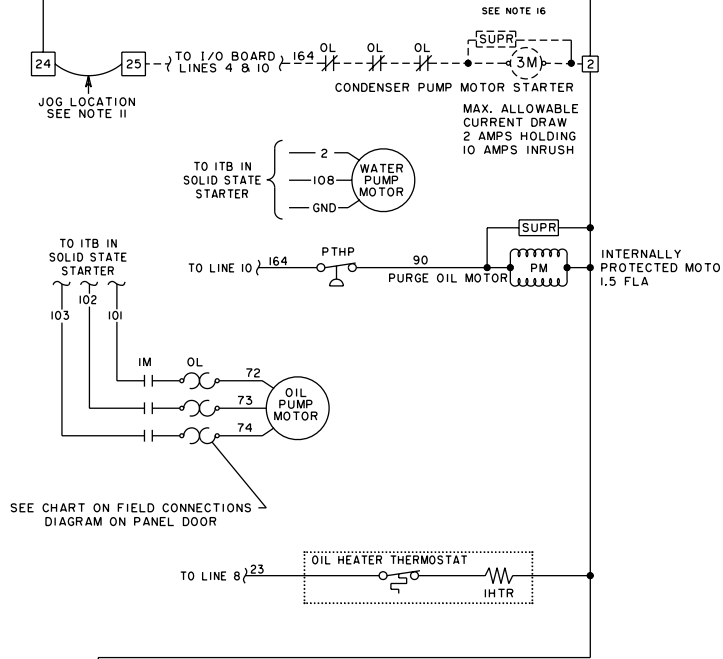

# ELEMENTARY DIAGRAM (Cont'd)

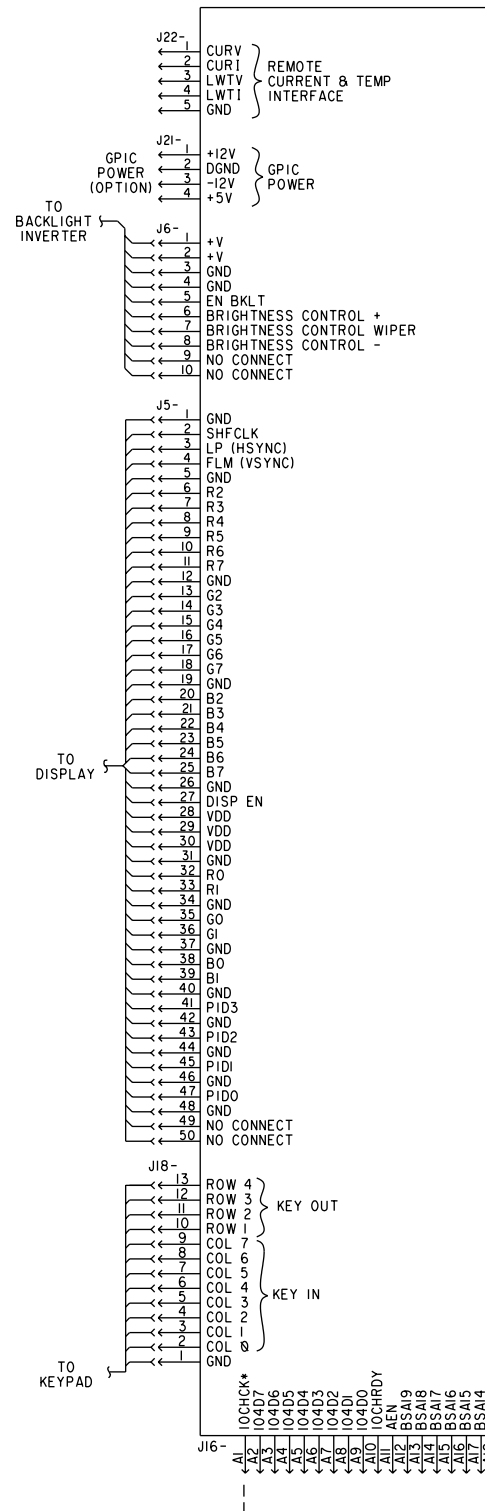





## TIMING DIAGRAM

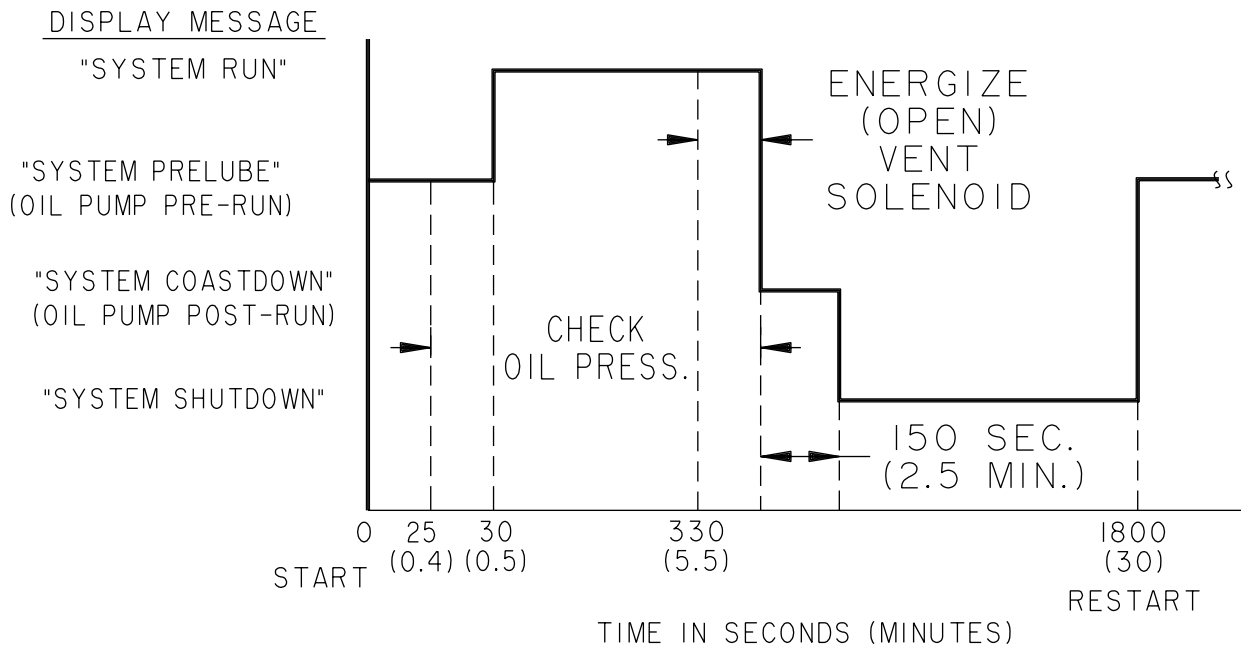







LD04580

### NOTES:

- This wiring diagram describes the standard electronic control scheme for use with an electromechanical starter. For details of standard modifications, refer to Product Form 160.55-PW7.
- Field wiring to be in accordance with the National Electrical Code as well as all other applicable codes and specifications. See Product Form 160.55-PW5 for field wiring connections.
- Numbers along the left side of diagram are line identification numbers. The numbers along the right side indicate the line number location of relay contacts. An underlined contact location signifies a normally closed contact.
- Main control panel Class 1 field wiring terminal connection points are indicated by numbers within a rectangle, i.e. 15. Main control panel factory wiring terminal connection points are indicated by numbers within a triangle, i.e. 5. Component terminal markings are indicated by numbers within a circle, i.e. C1. Numbers adjacent to circuit lines are the circuit identification numbers.
- To cycle unit on and off automatically with contacts other than those shown, install a cycling device between terminals 1 & 13 (line 38) (see note 7). If a cycling device is installed, jumper must be removed between terminals 1 & 13.
- To stop unit and not permit it to start again, install a stop device between terminals 1 & 8 (Line 33) (see note 7). A remote start-stop switch may be connected to terminals 1, 7 & 8 (Lines 32 & 33) (see note 7). Remote start-stop switch (Line 32) is operative only in the "remote" operating mode.
- Device contact rating to be 5 milliamperes @ 115 volts A.C.
- Contact rating is 5 Amp resistive @ 120 volts A.C. or 240 volts A.C.
- \_\_\_\_\_
- For wiring diagram of solid state starter, refer to product form 160.04-PW1.
- To check motor rotation on initial start-up, install momentary switch between terminals 24 & 25 (line 41). Depress start switch. After approx. 30 seconds, jog motor with momentary switch. When proper rotation is obtained, replace momentary switch with jumper. Switch must have a minimum contact rating of 2 FLA., 10 LRA at 115 Volts A.C.
- Solid state motor overload contact (CM) on solid state starter logic board in LCSSS is set to trip at 105% FLA.
- Contact rating is 5 Amps resistive @ 250 Volts A.C. & 30 Volts D.C., 2 Amp inductive (.4 PF) @ 250 Volts A.C. & 30 Volts D.C.
- Field connected control power supply is not required, as control transformer is supplied on the solid state starter.
- Wires 2\* and L\* are from solid state starter.
- Each 115VAC field-connected inductive load: i.e. relay coil, motor starter coil, etc., shall have a transient suppressor wired in parallel with its coil, physically located at the coil. Spare transient suppressors and control circuit fuses are supplied in a bag attached to cable clamp on left, inside wall of control panel.

# LEGEND

IHTR	THERMOSTATICALLY CONTROLLED 1000 WATT OIL HEATER
IM	3 PHASE OIL PUMP STARTER (MOUNTED IN PURGE PANEL)
3M	CONDENSER PUMP MOTOR STARTER
IR	COMPRESSOR MOTOR/ IHTR HEATER CONTROL RELAY (KI8 - LOCATED ON I/O BD.)
ISOL	VENT LINE SOLENOID VALVE
2SOL,4SOL	PURGE OIL SOLENOID VALVES
3SOL	PURGE AIR EXHAUST SOLENOID VALVE
ISS	DPDT 3 POSITION ROCKER SWITCH
ITB	TERMINAL BLOCK, FACTORY WIRING (IN SOLID STATE STARTER)
IT	CLASS 2 POWER SUPPLY TRANSFORMER
BFS	PURGE BOTTOM FLOAT SWITCH
CM	SOLID STATE OVERLOAD/POWER FAULT CONTACTS (PART OF LCSSS LOGIC BOARD)
FDT5	FAULTY DISCHARGE TEMP. SENSOR (PROVIDED BY RTI)
FLA	FULL LOAD AMPS (COMPRESSOR MOTOR)
FU	FUSE
HDT	REFRIG. HIGH DISCHARGE TEMP. (PROVIDED BY RT2)
HOP	HIGH OIL PRESSURE (PROVIDED BY TWO TRANSDUCERS)
HOT	HIGH OIL TEMPERATURE (PROVIDED BY RT3)
HP	HIGH PRESSURE CUTOUT (MOUNTED IN PURGE PANEL)
LCSSS	LIQUID COOLED SOLID STATE STARTER
LEP	LOW EVAPORATOR PRESSURE (PROVIDED BY EVAP. PRESS TRANSDUCER)
LLS	LIQUID LEVEL SENSOR (PROBE)
LOT	LOW OIL TEMPERATURE (PROVIDED BY RT3)
LWT	LOW WATER TEMPERATURE (PROVIDED BY RTI)
HGBP	HOT GAS BYPASS
MOV	METAL OXIDE VARISTOR
OL	MOTOR STARTER OVERLOADS
OP	LOW OIL PRESSURE (PROVIDED BY TWO TRANSDUCERS)
PAES	PURGE AIR EXHAUST SOLENOID VALVE (3 SOL)
PM	PURGE OIL MOTOR (MOUNTED IN PURGE PANEL)
PTHP	PURGE TANK HIGH PRESSURE CUTOUT (MOUNTED IN PURGE TANK)
POS	PURGE OIL SOLENOID VALVE (2 SOL & 4 SOL)
RTI-RT9	RESISTANCE TEMPERATURE SENSING ELEMENT
RES	RESISTOR
<span style="border: 1px solid black; padding: 2px;">SUPR</span>	TRANSIENT SUPPRESSOR
TFS	PURGE TOP FLOAT SWITCH
TB1, TB3, TB5, TB6 (TOP)	TERMINAL BLOCK, FACTORY WIRING — 
TB2, TB4, TB6 (BOTTOM)	TERMINAL BLOCK, FIELD CONNECTION — 
VMP	VANE MOTOR POTENTIOMETER
VMS	VANE MOTOR SWITCH (LOCATED IN PRV)
-----	FIELD WIRING
—————	FACTORY WIRING
.....	CIRCUIT BOARD OR ENCLOSURE BOUNDARY
→	JACK (JI, J2, ...)
⌋	PLUG (PI, P2, ...)
	WIRE ENTRANCE HOLE IN CONTROL PANEL
-----	OPTION (WHEN SUPPLIED) BY YORK.
-----	MECHANICAL LINKAGE
	SHIELDED CABLE
	METAL OXIDE VARISTOR
KI3, KI4, KI7	RELAYS MOUNTED ON I/O BOARD - SEE OPERATOR'S MANUAL
	TERMINAL LOCATED IN LCSSS (TB1)

LD04581

# CONNECTION DIAGRAM

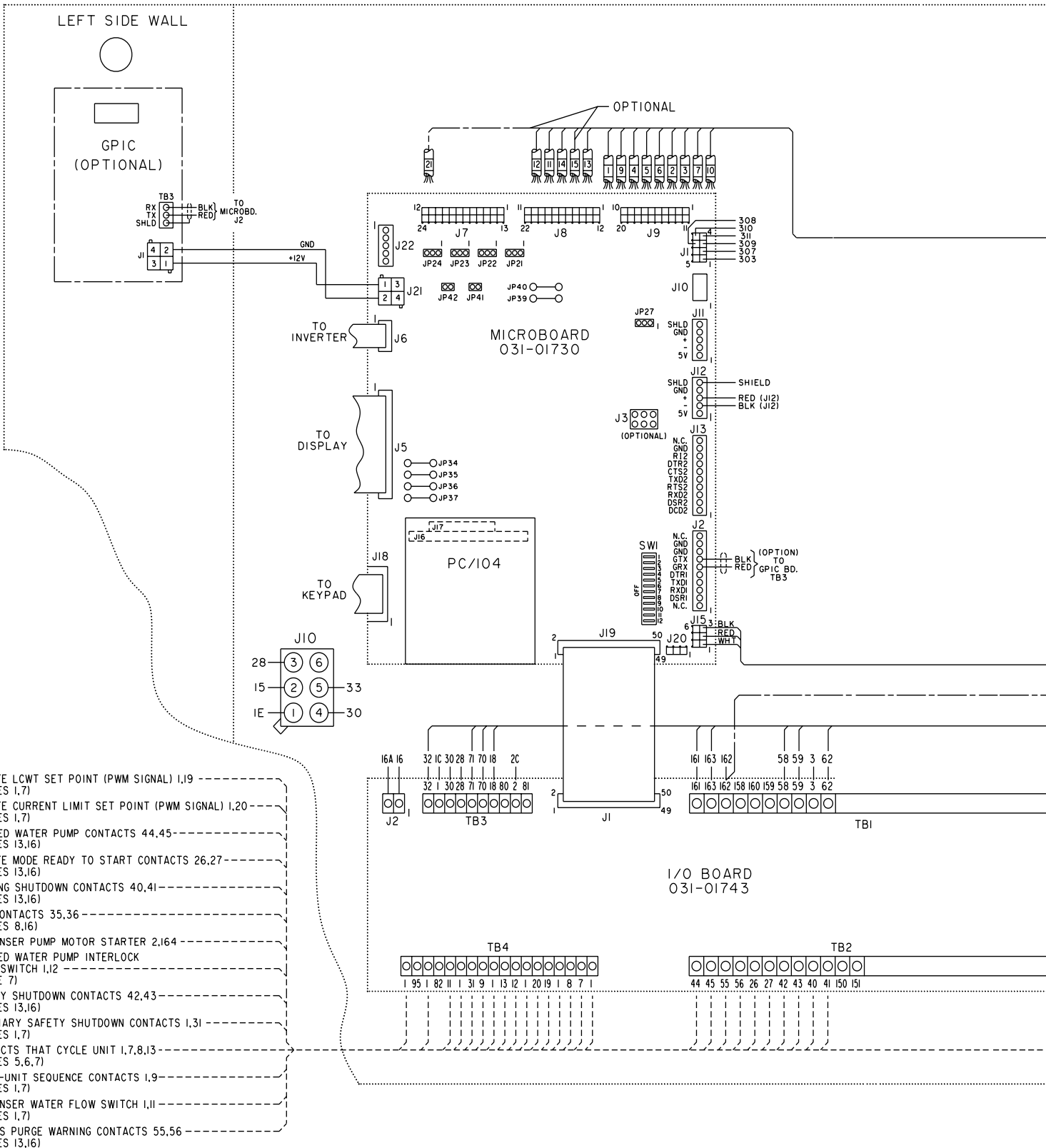



# CONNECTION DIAGRAM (Cont'd)

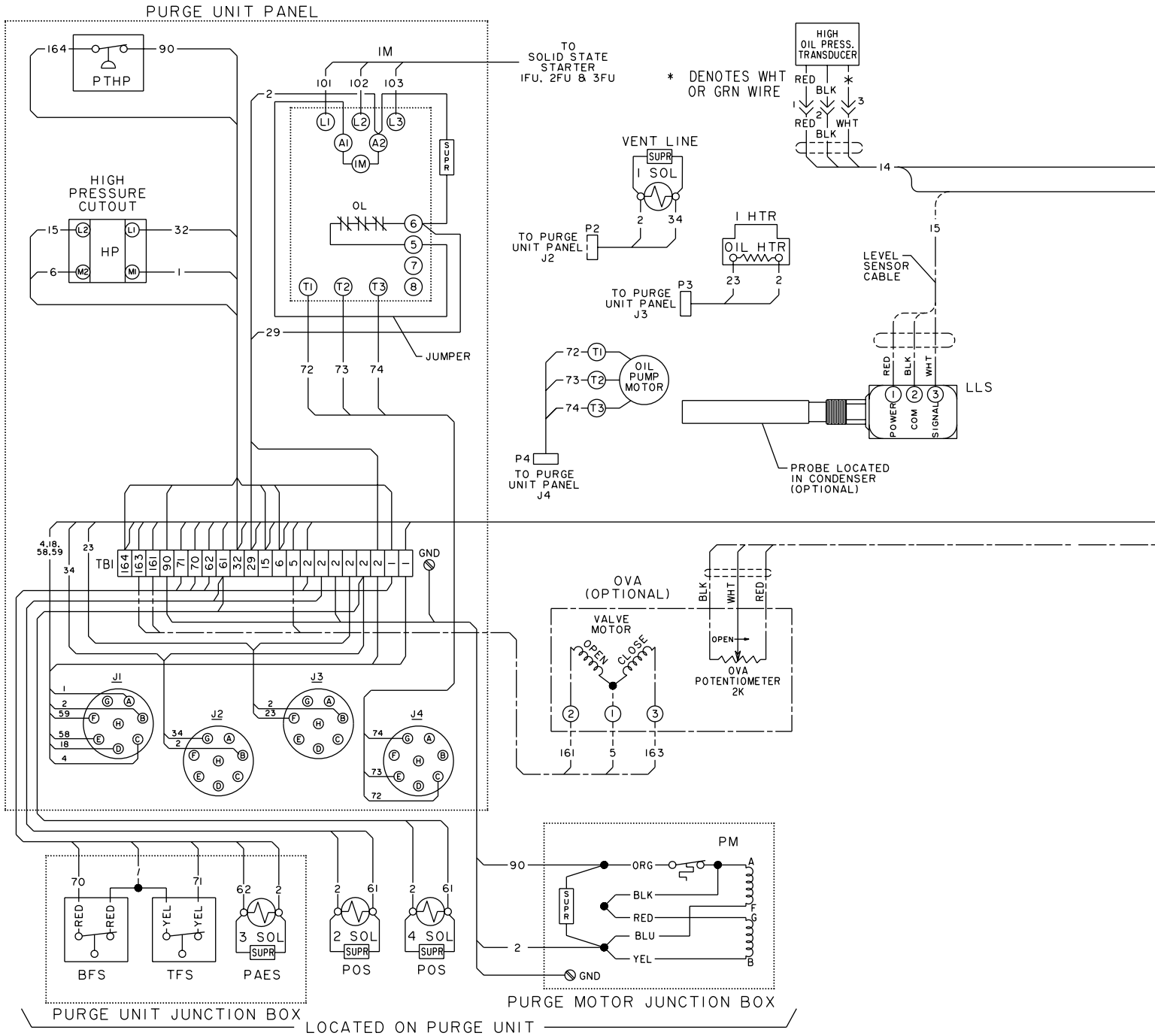

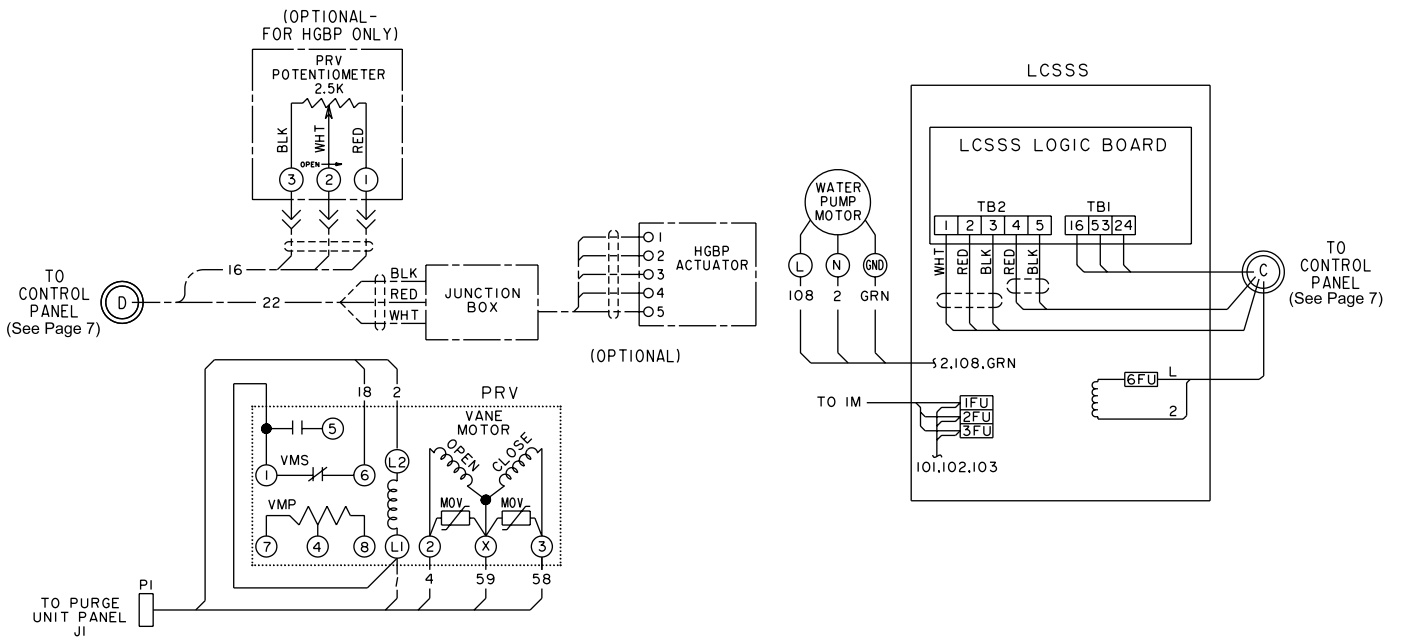
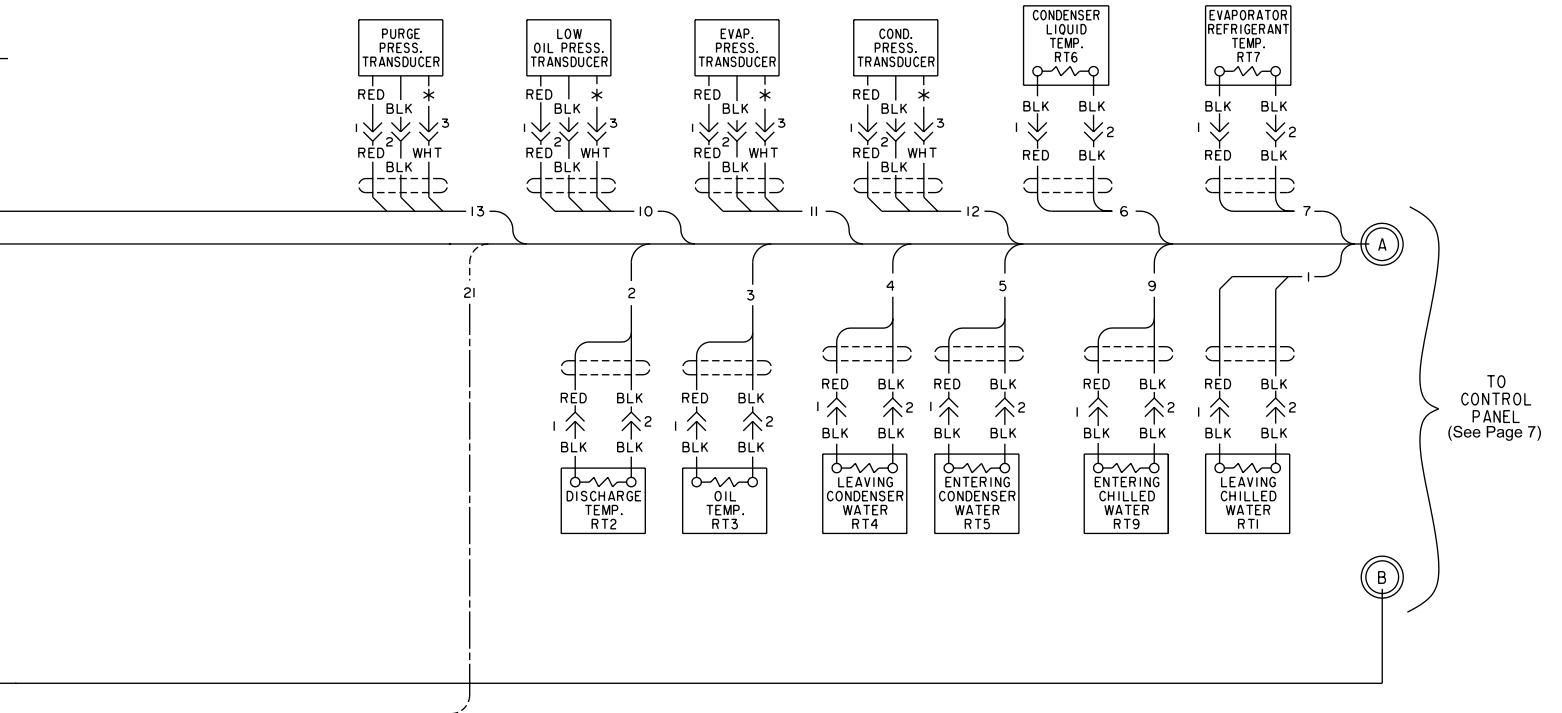

# INSIDE VIEW OF FRONT DOOR

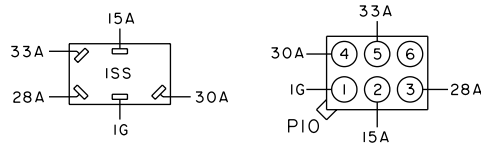
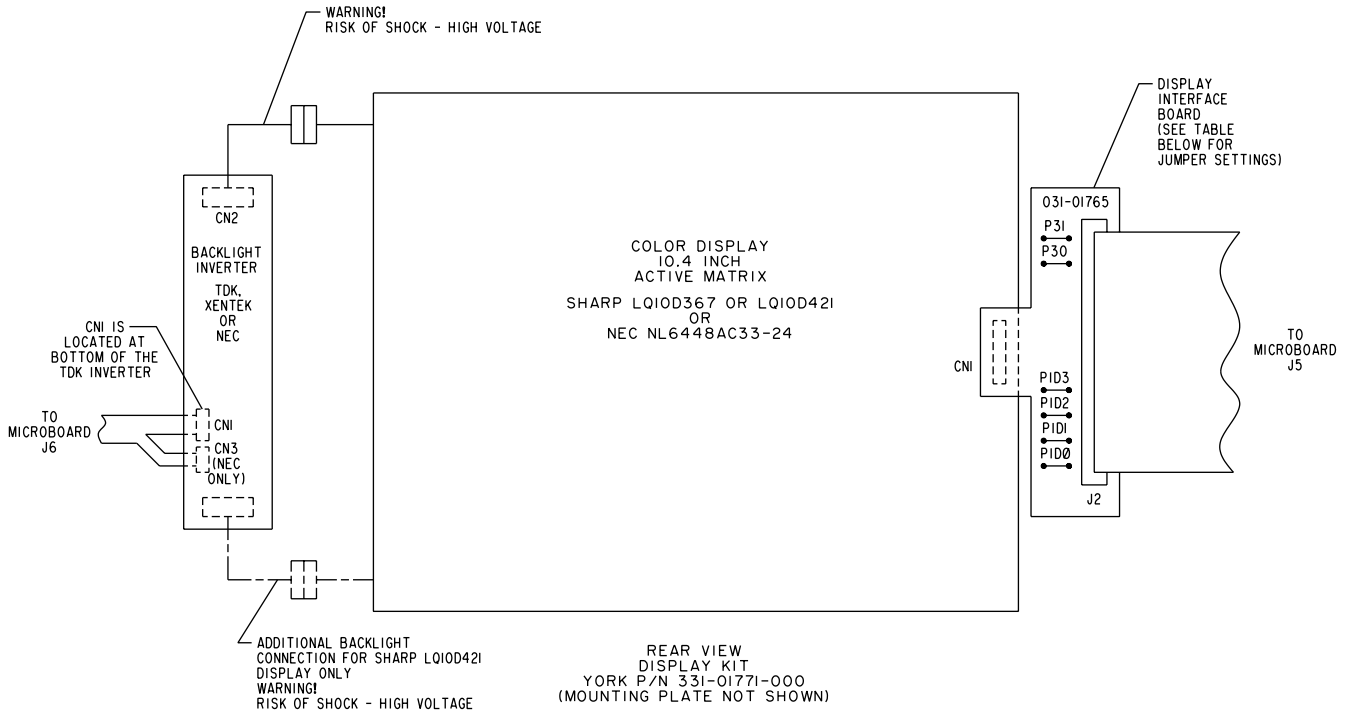

DISPLAY INTERFACE BOARD JUMPER SETTINGS

DISPLAY	P3O	P3I	P1D3	P1D2	P1D1	P1D0
SHARP LQ10D367	IN	IN	OUT	OUT	IN	OUT
SHARP LQ10D421	IN	IN	OUT	OUT	IN	OUT
NEC	OUT	OUT	OUT	OUT	OUT	IN

LD04584

**CHART 1 – OIL PUMP MOTOR AND STARTER FOR COMPRESSOR CODES B,C & E**

OIL PUMP MOTOR		OIL PUMP STARTER OVERLOAD HEATERS					
VOLTS-PH-HZ	FULL LOAD AMPS	MANUFACTURER	MANUFACTURER'S PART NO.	SETTING	TRIP AMPS	DUAL* ELEMENT FUSE SIZE	% DRW PROTECTION
200-3-60	3.00	CUTLER HAMMER	H2008B-3	A.0	4.0	12	135
208-3-60	2.90	CUTLER HAMMER	H2007B-3	B.75	3.7	12	126
220-3-60	2.90	CUTLER HAMMER	H2007B-3	B.75	3.7	10	126
230-3-60	2.90	CUTLER HAMMER	H2007B-3	B.75	3.7	10	126
240-3-60	3.00	CUTLER HAMMER	H2007B-3	C.0	3.8	10	126
440-3-60	1.45	CUTLER HAMMER	H2005B-3	B.0	1.8	5	125
460-3-60	1.45	CUTLER HAMMER	H2005B-3	B.0	1.8	5	125
480-3-60	1.45	CUTLER HAMMER	H2005B-3	B.0	1.8	5	125
550-3-60	1.30	CUTLER HAMMER	H2005B-3	B.0	1.8	5*	140
575-3-60	1.25	CUTLER HAMMER	H2005B-3	A.5	1.7	5*	133
600-3-60	1.23	CUTLER HAMMER	H2005B-3	A.5	1.7	5*	135
380-3-50	2.20	CUTLER HAMMER	H2006B-3	B.75	3.0	6	138
400-3-50	2.20	CUTLER HAMMER	H2006B-3	B.75	3.0	6	138
415-3-50	1.85	CUTLER HAMMER	H2006B-3	A.25	2.4	6	127

\* – Oil pump motor fuses located in solid state starter.

\* – Single element fuse size.

**CHART 2 – OIL PUMP MOTOR AND STARTER FOR COMPRESSOR CODES F**

OIL PUMP MOTOR		OIL PUMP STARTER OVERLOAD HEATERS					
VOLTS-PH-HZ	FULL LOAD AMPS	MANUFACTURER	MANUFACTURER'S PART NO.	SETTING	TRIP AMPS	DUAL ELEMENT FUSE SIZE	% DRW PROTECTION
200-3-60	3.90	CUTLER HAMMER	H2008B-3	B.5	5.3	12	136
208-3-60	3.70	CUTLER HAMMER	H2008B-3	A.75	4.7	12	126
220-3-60	3.70	CUTLER HAMMER	H2008B-3	A.75	4.7	10	126
230-3-60	3.70	CUTLER HAMMER	H2008B-3	A.75	4.7	10	126
240-3-60	3.70	CUTLER HAMMER	H2008B-3	A.75	4.7	10	126
440-3-60	1.85	CUTLER HAMMER	H2006B-3	A.25	2.4	4	127
460-3-60	1.85	CUTLER HAMMER	H2006B-3	A.25	2.4	4	127
480-3-60	1.85	CUTLER HAMMER	H2006B-3	A.25	2.4	4	127
550-3-60	1.63	CUTLER HAMMER	H2005B-3	A.0	2.2	5*	137
575-3-60	1.56	CUTLER HAMMER	H2005B-3	C.0	2.1	5*	137
600-3-60	1.50	CUTLER HAMMER	H2005B-3	B.75	2.1	5*	137
380-3-50	2.20	CUTLER HAMMER	H2006B-3	B.75	3.0	6	138
400-3-50	2.20	CUTLER HAMMER	H2006B-3	B.75	3.0	6	138
415-3-50	1.85	CUTLER HAMMER	H2006B-3	A.25	2.4	6	127

\* – Oil pump motor fuses located in solid state starter.

\* – Single element fuse size.

PRESSURE-TEMPERATURE CHART

APPLICATION		DEVICE	UNITS	OPERATING POINT			
CHILLED WATER	BRINE			ON RISE		ON FALL	
✓	✓	HDT	DEG.F/DEG.C	220/104.4		219/103.9	
✓	✓	HOT	DEG.F/DEG.C	180/82.2		179/81.7	
✓	✓	OP	PSID/kPa	20/137.9		15/103.4	
✓	✓	PAES	PSIA/kPa	90/620.4		80/551.5	
✓	✓	HP	PSIA/kPa	CUT-OUT 29.7/204.8 **	PROGRAMMABLE PER OPERATOR'S MANUAL FORM 160.55-01 *		CUT-IN 23.7/163.4 **
✓		LEP (RII)	PSIA/kPa	CUT-IN 5.43/37.4	ALLOW PRV OPENING 5.65/39.0	INHIBIT PRV OPENING 5.55/38.3	CUT-OUT 5.42/37.4
✓		LEP (RI23)	PSIA/kPa	CUT-IN 4.41/30.4	ALLOW PRV OPENING 4.70/32.4	INHIBIT PRV OPENING 4.50/31.0	CUT-OUT 4.40/30.3
	✓	ILEP	PSIG				
✓	✓	HOP	PSID/kPa	60/413.7		59/406.8	
✓	✓	FDS	DEG.F/DEG.C	30.0/-1.10		29.9/-1.20	
✓		LWT	DEG.F/DEG.C	PROGRAMMABLE PER OPERATOR'S MANUAL FORM 160.55-01			
	✓	LWT	DEG.F/DEG.C				
✓	✓	LOT	DEG.F/DEG.C	71.0/21.7		55.0/12.8	
✓	✓	P THP	PSIA/kPa	105/723		99/682 MANUAL RESET	

LD04572

- \* Function provided by condenser transducer.
- \*\* HP threshold for inputs built in Wuxi, China to be as follows:  
 Cut-out – 29.1/200.7  
 Cut-in – 23.1/159.3  
 Inhibit Prv – 28.2/194.5  
 Allow Prv – 28.0/193.1



Proud Sponsor  
of the 2000  
U.S. Olympic Team

36USC380