

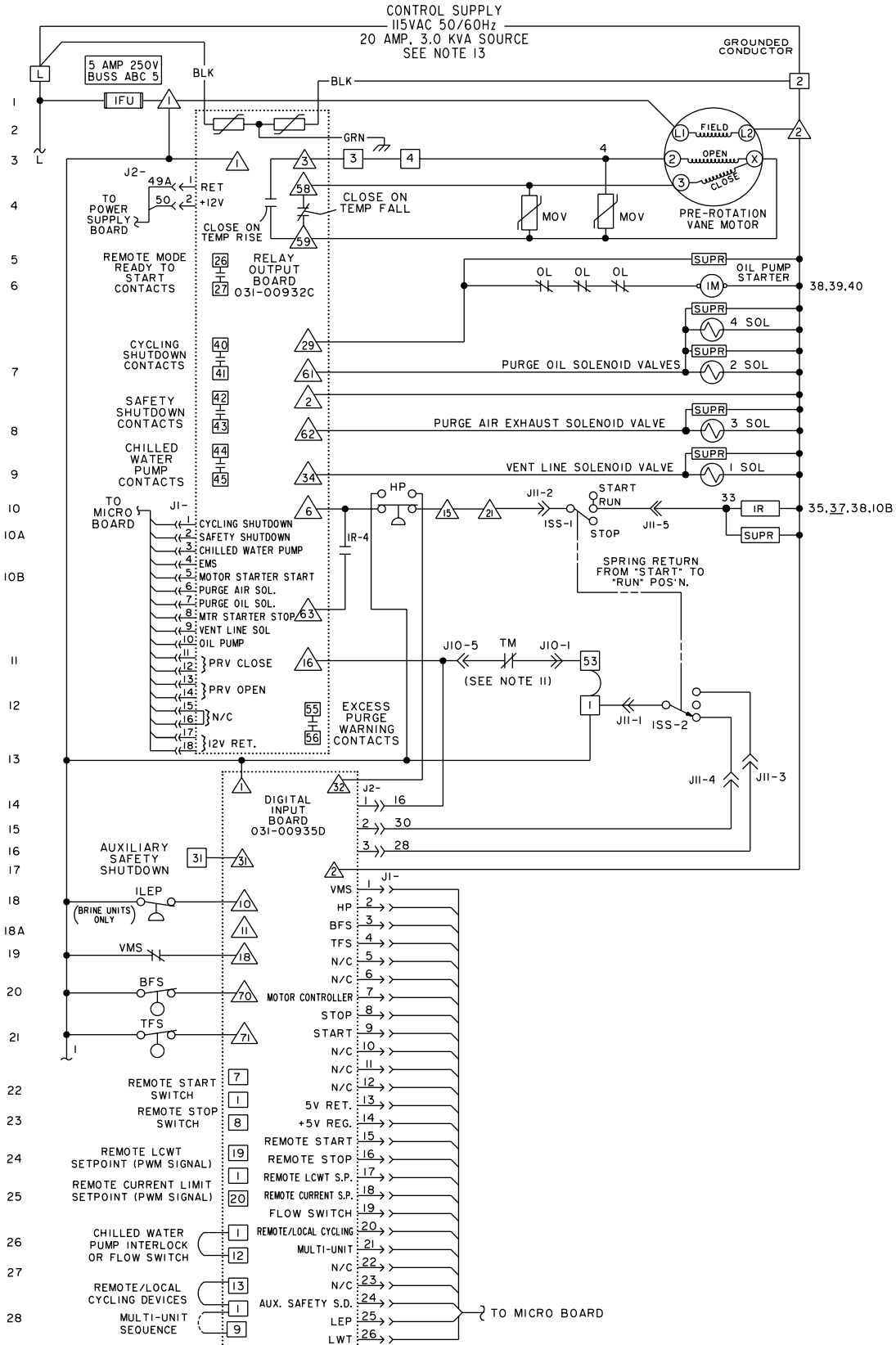

# ELEMENTARY DIAGRAM

035-12636 (REV. D)



LD02200

# ELEMENTARY DIAGRAM (Cont'd.)

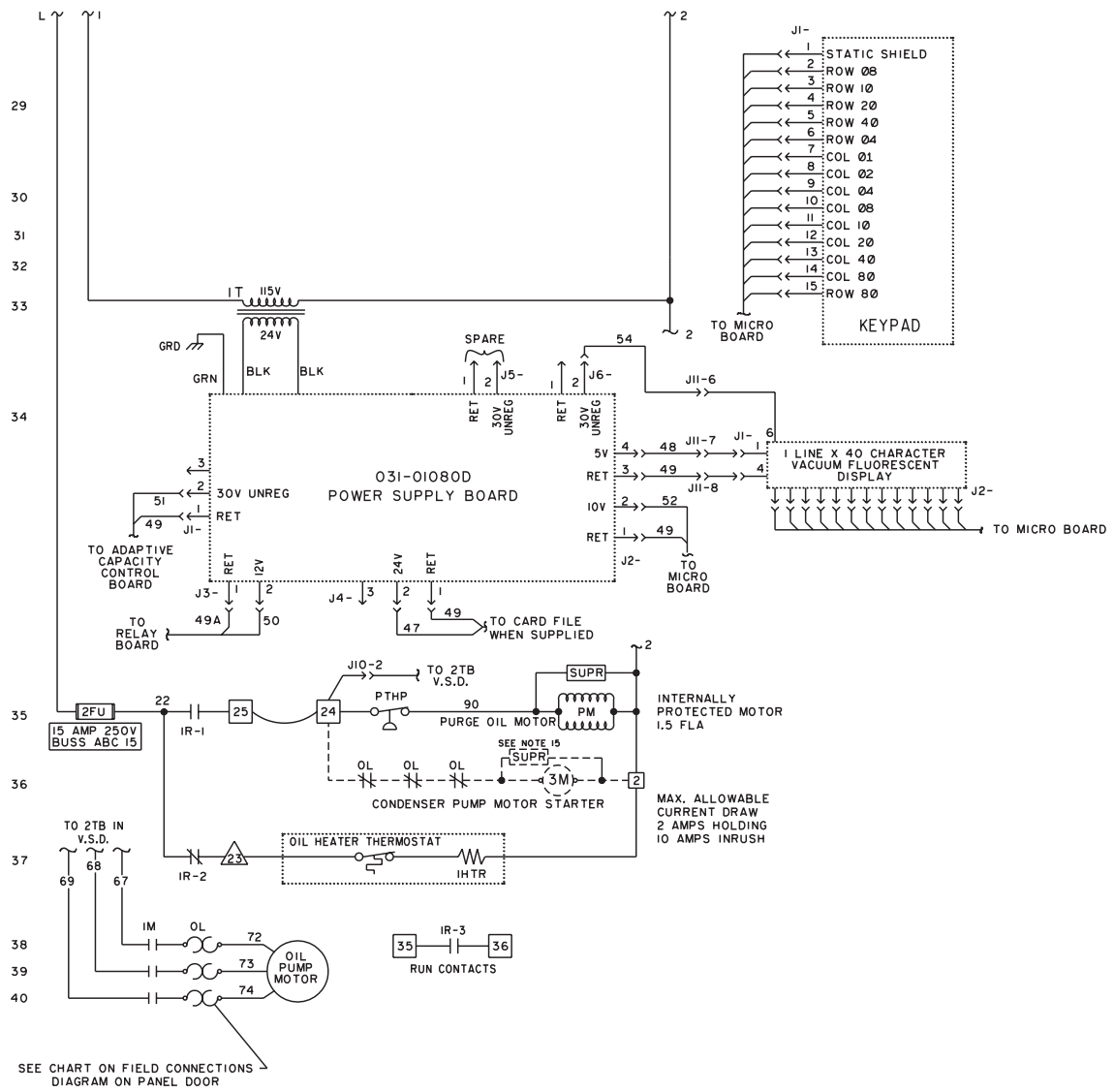



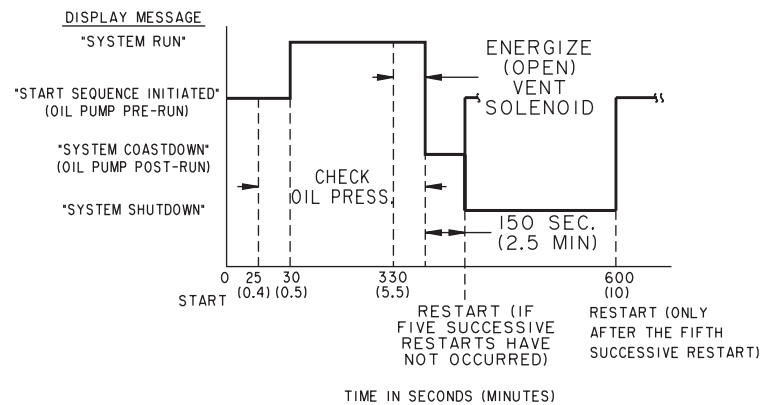

LD02201

## TIMING DIAGRAM















LD02202

# LEGEND

IHTR	THERMOSTATICALLY CONTROLLED 1000 WATT OIL HEATER	PM	PURGE OIL MOTOR (MOUNTED ON TOP OF CONDENSER)
IM	3 PHASE OIL PUMP STARTER (MOUNTED IN PURGE PANEL)	POS	PURGE OIL SOLENOID VALVE (2SOL & 4SOL)
3M	CONDENSER PUMP MOTOR STARTER	PTHP	PURGE TANK HIGH PRESSURE CUTOUT (MOUNTED IN PURGE PANEL)
IR	VSD RUN / HEATER CONTROL RELAY	RTI-RT9	RESISTANCE TEMPERATURE SENSING ELEMENT
ISOL	VENT LINE SOLENOID VALVE	RES	RESISTOR
2SOL,4SOL	PURGE OIL SOLENOID VALVES		TRANSIENT SUPPRESSOR
3SOL	PURGE AIR EXHAUST SOLENOID VALVE	TFS	PURGE TOP FLOAT SWITCH
ISS	DPDT 3 POSITION ROCKER SWITCH	TM	RUN CONTACT FROM V.S.D.
2TB	TERMINAL BLOCK, FACTORY WIRING (IN V.S.D.)	TBI,TB3,TB6	TERMINAL BLOCK, FACTORY WIRING — 
3TB	TERMINAL BLOCK, FACTORY WIRING (IN V.S.D.)	TB2,TB4, TB5	TERMINAL BLOCK, FIELD CONNECTION — 
IT	CLASS 2 POWER SUPPLY TRANSFORMER	VMP	VANE MOTOR POTENTIOMETER
BFS	PURGE BOTTOM FLOAT SWITCH	VMS	VANE MOTOR SWITCH
FDT5	FAULTY DISCHARGE TEMP. SENSOR (PROVIDED BY RTI)	-----	FIELD WIRING
FLA	FULL LOAD AMPS (COMPRESSOR MOTOR)	—————	FACTORY WIRING
FU	FUSE	.....	CIRCUIT BOARD OR ENCLOSURE BOUNDARY
HDT	REFRIG. HIGH DISCHARGE TEMP. (PROVIDED BY RT2)	→	JACK (J1,J2,...)
HOP	HIGH OIL PRESSURE (PROVIDED BY TWO TRANSDUCERS)	⌋	PLUG (P1,P2,...)
HOT	HIGH OIL TEMPERATURE (PROVIDED BY RT3)		WIRE ENTRANCE HOLE IN CONTROL PANEL
HP	HIGH PRESSURE CUTOUT (MOUNTED IN PURGE PANEL)	-----	OPTION (WHEN SUPPLIED) BY YORK.
LEP	LOW EVAPORATOR PRESSURE (PROVIDED BY EVAP. PRESS TRANSDUCER)	-----	MECHANICAL LINKAGE
ILEP	LOW EVAPORATOR PRESSURE CUTOUT (BRINE UNITS ONLY)	-----	SHIELDED CABLE
LOT	LOW OIL TEMPERATURE (PROVIDED BY RT3)		METAL OXIDE VARISTOR
LWT	LOW WATER TEMPERATURE (PROVIDED BY RTI)		
MOV	METAL OXIDE VARISTOR		
OL	MOTOR STARTER OVERLOADS		
OP	LOW OIL PRESSURE (PROVIDED BY TWO TRANSDUCERS)		
PAES	PURGE AIR EXHAUST SOLENOID VALVE (3SOL)		

LD02203

## NOTES:

- This wiring diagram describes the standard electronic control scheme for use with a YORK V.S.D. For details of standard modifications, refer to Product Form 160.48-PA14.
- Field wiring to be in accordance with the National Electrical Code as well as all other applicable codes and specifications. See Product Form 160.48-PA15 for field wiring connections.
- Numbers along the left side of diagram are line identification numbers. The numbers along the right side indicate the line number location of relay contacts. An underlined contact location signifies a normally closed contact.
- Main control panel Class 1 field wiring terminal connection points are indicated by numbers within a rectangle, i.e. . Main control panel factory wiring terminal connection points are indicated by numbers within a triangle, i.e. . Component terminal markings are indicated by numbers within a circle, i.e. . Numbers adjacent to circuit lines are the circuit identification numbers.
- To cycle unit on and off automatically with contacts other than those shown, install a cycling device between terminals  &  (line 27) (see note 7). If a cycling device is installed, jumper must be removed between terminals  & .
- To stop unit and not permit it to start again, install a stop device between terminals  &  (Line 23) (see note 7). A remote start-stop switch may be connected to terminals ,  &  (Lines 22 & 23) (see note 7). Remote start-stop switch (Line 22) is operative only in the "remote" operating mode.
- Device contact rating to be 5 milliamperes @ 115 volts A.C.
- Contact rating is 5A resistive @ 120 volts A.C. or 240 volts A.C.
- \_\_\_\_\_
- For wiring diagram of V.S.D., refer to Product Form 160.48-PA16.
- Run contact (TM) on V.S.D. Logic Board is set to trip at 105% FLA.
- Contact rating is 5 amps resistive @ 250 volts A.C. or 30 volts D.C., 2 amp inductive (.4 PF) @ 250 volts A.C. & 30 volts D.C.
- Field connected control power supply is not required, as control transformer is supplied on the V.S.D.
- Wires 2\* and L\* are from V.S.D.
- Each 115VAC field-connected inductive load: i.e. relay coil, motor starter coil, etc., shall have a transient suppressor wired in parallel with its coil, physically located at the coil. Spare transient suppressors and control circuit fuses are supplied in a bag attached to the top of the hinged panel.

### ELEMENTARY DIAGRAM (Cont'd.)

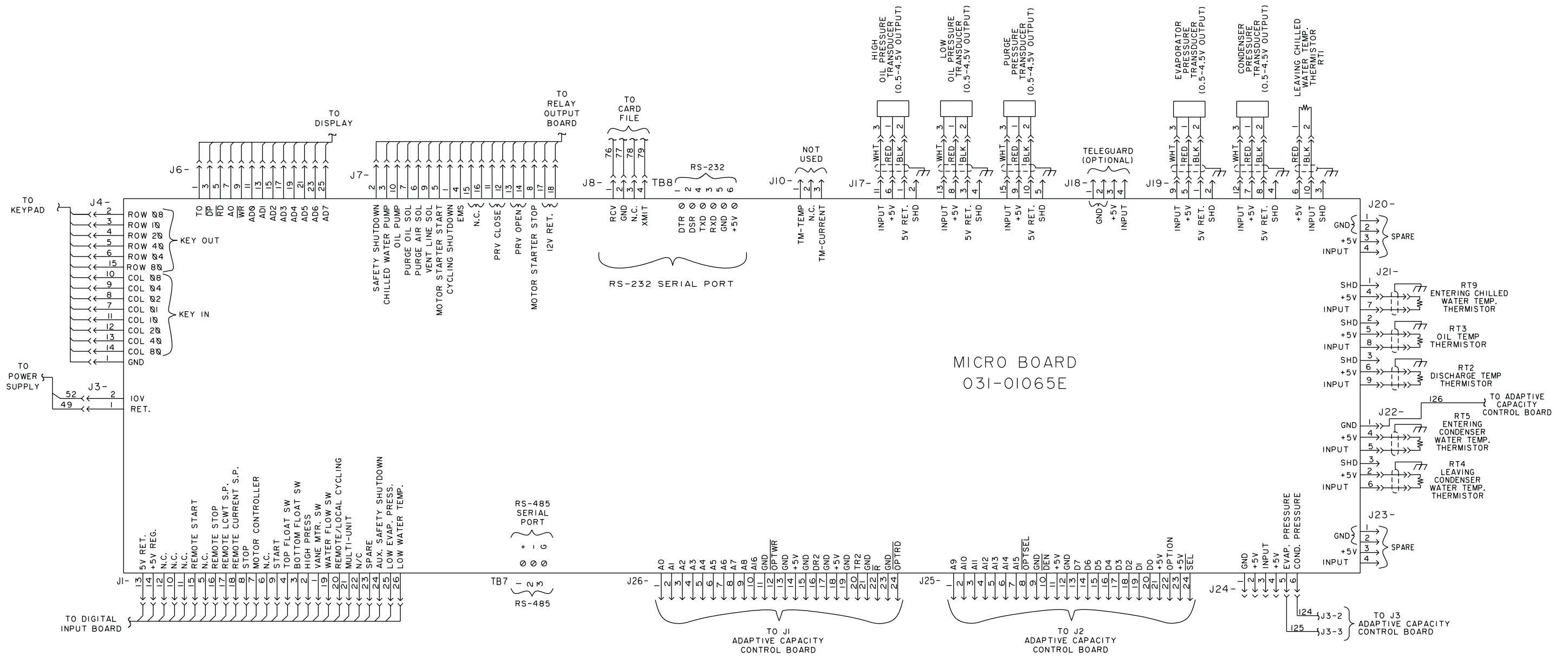

LD02204

PRESSURE-TEMPERATURE CHART							
APPLICATION		DEVICE	UNITS	OPERATING POINT			
CHILLED WATER	BRINE			ON RISE		ON FALL	
✓	✓	HDT	DEG.F/DEG.C	220/104.4		219/103.9	
✓	✓	HOT	DEG.F/DEG.C	180/82.2		179/81.7	
✓	✓	OP	PSID/kPa	20/137.9		15/103.4	
✓	✓	PAES	PSIA/kPa	90/620.4		80/551.5	
✓	✓	HP	PSIA/kPa	CUT-OUT 29.7/204.8	INHIBIT PRV OPENING * 28.8/198.6	ALLOW PRV OPENING * 28.6/197.2	CUT-IN 23.7/163.4
✓		LEP (R11)	PSIA/kPa	CUT-IN 5.43/37.4	ALLOW PRV OPENING 5.65/39.0	INHIBIT PRV OPENING 5.55/38.3	CUT-OUT 5.42/37.4
✓		LEP (R123)	PSIA/kPa	CUT-IN 4.41/30.4	ALLOW PRV OPENING 4.70/32.4	INHIBIT PRV OPENING 4.50/31.0	CUT-OUT 4.40/30.3
	✓	ILEP	PSIG				
✓	✓	HOP	PSID/kPa	60/413.7		59/406.8	
✓	✓	FDTS	DEG.F/DEG.C	30.0/-1.10		29.9/-1.20	
✓		LWT	DEG.F/DEG.C	CHILLED LIQUID TEMP. SETPOINT		AT OR ABOVE LCWT= 40/4.4, LWT=4/2.2 BELOW THE CHILLED LIQ. TEMP. SETPOINT: WHEN THE SETPOINT IS RAISED, LWT= 36/2.2 FOR 10 MINUTES. BELOW LWCT=40/4.4, LWT=36/2.2	
	✓	LWT	DEG.F/DEG.C	CHILLED LIQUID TEMP. SETPOINT		LWT = 4/2.2 BELOW THE CHILLED LIQ. TEMP. SETPOINT	
✓	✓	LOT	DEG.F/DEG.C	71.0/21.7		55.0/12.8	
✓	✓	PTHP	PSIA/kPa	105/723		99/682 MANUAL RESET	

\* - FUNCTION PROVIDED BY CONDENSER TRANSDUCER

LD02205





# ELEMENTARY DIAGRAM

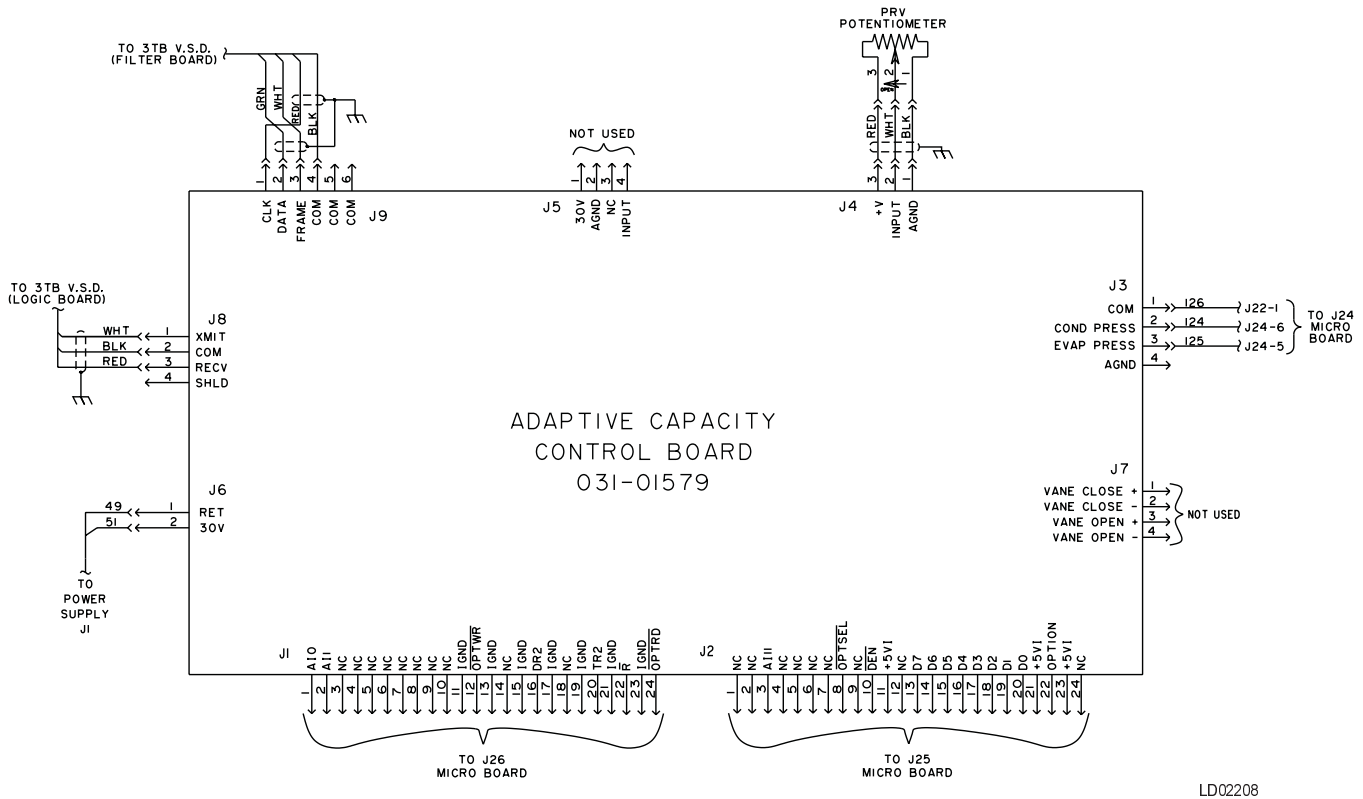

**CHART 2 – OIL PUMP MOTOR AND STARTER**

OIL PUMP MOTOR			OIL PUMP STARTER OVERLOAD HEATERS					
COMPR.	VOLTS-PH-HZ	FULL LOAD AMPS	MANUFACTURER	MANUFACTURER'S PART NO.	SETTING	TRIP AMPS	MAXIMUM DUAL ELEMENT FUSE SIZE*	% PROTECTION
B, C, E	440-3-60	1.61	CUTLER HAMMER	H2007B-3	A	2.254	5	134
	460-3-60	1.68	CUTLER HAMMER	H2007B-3	A	2.352	5	128
	480-3-60	1.75	CUTLER HAMMER	H2007B-3	A	2.450	5	123
F	440-3-60	2.02	CUTLER HAMMER	H2007B-3	B	2.828	5	129
	460-3-60	2.15	CUTLER HAMMER	H2007B-3	B	3.010	5	121
	480-3-60	2.29	CUTLER HAMMER	H2007B-3	C	3.206	5	133

\* Oil pump motor supply fuses located in Variable Speed Drive.

035-14044 (REV. -)

