



Supersedes: Nothing

FORM 160.48-PA14 (796)

**FIELD CONTROL MODIFICATIONS DIAGRAM  
FOR MICROCOMPUTER CONTROL CENTER  
MILLENNIUM™ MODEL YT LIQUID CHILLERS**

YORK INTERNATIONAL CORPORATION  
P.O. Box 1592, York, PA 17405

CONTRACTOR \_\_\_\_\_  
ORDER NO. \_\_\_\_\_  
YORK CONTRACT NO. \_\_\_\_\_  
YORK ORDER NO. \_\_\_\_\_

PURCHASER \_\_\_\_\_  
JOB NAME \_\_\_\_\_  
LOCATION \_\_\_\_\_  
ENGINEER \_\_\_\_\_

REFERENCE      DATE \_\_\_\_\_

APPROVAL      DATE \_\_\_\_\_

CONSTRUCTION      DATE \_\_\_\_\_

For use with York Centrifugal Liquid Chilling Units shown below.

MODELS YT GO A1 B1 thru YT L6 D8 F2 (STYLE H)

**JOB DATA:**

CHILLER MODEL NO. \_\_\_\_\_

CHILLER MODEL NO. \_\_\_\_\_

NO. OF UNITS \_\_\_\_\_

NO. OF UNITS \_\_\_\_\_

TYPE OF STARTING \_\_\_\_\_

TYPE OF STARTING \_\_\_\_\_

**SEE FIGURES:** \_\_\_\_\_

**Included by York for Field Installation (by others) are:**

|   | YES                      | NO                       | Per Unit |
|---|--------------------------|--------------------------|----------|
| One—Two Unit Sequence Control Kit, Part No. 466-61597T              | <input type="checkbox"/> | <input type="checkbox"/> | _____    |
| Remote Current Limit Setpoint Card, Part No. 031-00814-000          | <input type="checkbox"/> | <input type="checkbox"/> | _____    |
| Remote Temperature Control Point Reset Card, Part No. 031-00814-000 | <input type="checkbox"/> | <input type="checkbox"/> | _____    |
| Card File, Part No. 031-00827-000                                   | <input type="checkbox"/> | <input type="checkbox"/> | _____    |
| Condenser Water Temperature Sensor Kit, Part No. 375-01738-000      | <input type="checkbox"/> | <input type="checkbox"/> | _____    |
| Condenser Water Flow Switch, FS8W                                   | <input type="checkbox"/> | <input type="checkbox"/> | _____    |
| York Remote Chiller Communications (See Instruction 160.48-NOM4.1)  | <input type="checkbox"/> | <input type="checkbox"/> | _____    |

**ENERGY MANAGEMENT SYSTEMS**

Millennium Chiller unit design allows for ease of interfacing with Energy Management Systems (EMS). The MicroComputer Control Center includes unit status contacts, provisions for remote control inputs and provisions for remote setpoint reset of leaving chilled liquid temperature and current limit for EMS interfacing. See note 7.

- Remote Mode Ready to Start—See Fig. A.
- Cycling Shutdown—See Fig. B.
- Safety Shutdown—See Fig. C.
- Run (System Operating)—See Fig. D.

Four sets of unit status contacts are factory furnished through a field wiring terminal board in the MicroComputer Control Center. Each set of contacts are single pole, normally open, rated at 5 amperes resistive at 240 VAC. Chiller unit status contacts are provided for unit:

Three sets of inputs are available to the EMS, allowing for remote control of unit operation. Input device contact rating shall be 5 milliamperes at 115VAC. Field wiring terminal board (TB2) in the MicroComputer Control Center permits connection for the following operation:

## ENERGY MANAGEMENT SYSTEMS (Continued)

- Remote Stop Contacts—See Fig. E.
- Remote Start Contacts—See Fig. E.
- Remote/Local Cycling Devices—See Fig. F.

The Chiller (unless equipped with a York Variable Speed Drive (VSD) should not be cycled by the Energy Management System because the large motor used to drive the centrifugal compressor is limited to one start per 30 minutes. Instead, it is possible to limit the compressor motor amp draw indirectly or directly by the following methods:

*Note—If unit is equipped with a York VSD, the motor used to drive the centrifugal compressor is limited to five successive restarts, after which one 10 minute anti-recycle period takes place before the next five successive restarts.*

1. Application of Sequence Control Kit, so only one unit is running, when a single unit can carry the cooling load—See Fig. J.
2. When multiple Chiller installations are controlled by an EMS, remote start and stop contacts are available to start and stop each Chiller per Fig. E. Contact rating shall be 5 milliamperes at 115 volts A.C.
3. The MicroComputer Control Center has a programmable time clock function as a standard feature with holiday capability. This offers one preset automatic Start-Stop per day on a seven day calendar basis with the ability to program a single additional holiday start and stop time up to a week in advance. Chilled water pump control contacts (see Note 13) are also provided, allowing for efficient automatic operation of the chilled water pump to reduce energy. Two chilled water pump operating modes are available via the CHW PUMP programming jumper (J54) on the microboard. With jumper J54 installed, the chilled water pump operates for 30 seconds prior to Chiller start, during Chiller operation, coastdown, and LWT cycling shutdowns. With jumper J54 removed, the chilled water pump operates as above plus it operates during MULTI-UNIT and REMOTE/LOCAL cycling shutdowns.
4. Reduce the compressor-motor KW input (and thus amps), by raising the leaving chilled liquid temperature through remote temperature control setpoint in the "remote" operating mode. When remote temperature reset is accomplished by supplying a 1 to 11 second pulse-width modulated signal, refer to Fig. P. Through use of the remote temperature control setpoint option (at additional cost) card and Card File, the leaving chilled liquid temperature may be reset via a 4 to 20 mA D.C. current signal, a 0 to 10 volt D.C. signal, or a single contact closure per Fig. W.
5. Current limiting of demand during pulldown may be accomplished by using the standard PULLDOWN DEMAND LIMIT function provided in the MicroComputer Control Center. The "Pulldown Demand Limit" key can be programmed to limit compressor motor current from 40 to 100 percent of full load amperes, for 1 to 255 minutes following each compressor start. For more details refer to MicroComputer Control Center Instructions, Form 160.48-O1.
6. Controlling the maximum allowable compressor motor amps from 40 to 100% through remote current limit setpoint. Refer to Fig. Q when the remote current limit is accomplished by supplying a 1 to 11 second pulse-width modulated signal in the "remote" operating mode. An option (at additional cost) card and Card File is available for remote current limit setpoint via a 4 to 20 mA D.C. current signal, a 0 to 10 volt D.C. signal, or a single contact closure per Fig. V.
7. The York ISN Facility Automation System may be interfaced with the Chiller MicroComputer Control Center to provide unified Chiller plant system control. The ISN along with the York-Talk Communication Link directly communicate with the MicroComputer Control Center using a single twisted pair of wires. All temperatures, pressures, safety alarms and cycling information known to the MicroComputer Control Center are then available to the ISN for integrated Chiller plant control, data logging and, local and remote operator displays. The York-Talk Communication Link also allows the ISN to start, stop, and reset the Chiller's leaving chilled water and current limit setpoints.

## LIST OF FIGURES

|         |  |       |
|---------|--|-------|
| FIG. A  | — REMOTE MODE READY TO START CONTACTS .....  | 4     |
| FIG. B  | — CYCLING SHUTDOWN CONTACTS .....  | 4     |
| FIG. C  | — SAFETY SHUTDOWN CONTACTS .....   | 5     |
| FIG. D  | — RUN CONTACTS .....   | 5     |
| FIG. E  | — REMOTE START-STOP CONTACTS FROM ENERGY MANAGEMENT SYSTEM .....   | 6     |
| FIG. F  | — REMOTE/LOCAL CYCLING DEVICES .....   | 6     |
| FIG. G  | — MULTI-UNIT SEQUENCE .....  | 7     |
| FIG. H  | — CONDENSER WATER FLOW INTERLOCK .....   | 7     |
| FIG. J  | — TWO UNIT SEQUENCE CONTROL (KIT) .....  | 8     |
| FIG. K  | — MULTIPLE UNITS (TWO)—SERIES OPERATION .....  | 8     |
| FIG. L  | — MULTIPLE UNITS (TWO)—PARALLEL OPERATION—INDIVIDUAL PUMPS .....   | 9     |
| FIG. M  | — MULTIPLE UNITS (TWO)—PARALLEL OPERATION—SINGLE CHILLED WATER PUMP .....                                  | 9     |
| FIG. N  | — ELECTRO-MECHANICAL STARTER MANUAL RESET OVERLOADS .....  | 9     |
|         | (2300 TO 4160 VOLTS U.L. OR C.S.A. APPROVED UNITS ONLY)  |       |
| FIG. P  | — REMOTE LEAVING CHILLED WATER TEMPERATURE SETPOINT WITH PWM SIGNAL .....                                  | 10    |
| FIG. Q  | — REMOTE CURRENT LIMIT SETPOINT WITH PWM SIGNAL .....  | 10    |
| FIG. R  | — MICRO BOARD JUMPERS FOR AUTO/MANUAL RESTART AFTER POWER FAILURE<br>OR ENGLISH/METRIC DISPLAY UNITS ..... | 11    |
| FIG. S  | — CONDENSER WATER TEMPERATURE SENSORS (KIT) .....  | 11    |
| FIG. U  | — CARD FILE .....  | 12    |
| FIG. V  | — REMOTE CURRENT LIMIT SETPOINT—OPTION CARD #1 .....   | 13-14 |
| FIG. W  | — REMOTE LEAVING CHILLED WATER TEMPERATURE SETPOINT OPTION CARD #2 .....                                   | 15-16 |
| FIG. X  | — REMOTE START-STOP PUSHBUTTON STATION .....   | 17    |
| FIG. Y  | — EXTERNAL SIGNAL FOR REFRIGERATION UNIT FAILURE .....   | 17    |
| FIG. AA | — RUN CONTACTS/REMOTE RUN LIGHT AND SHUTDOWN INDICATOR PLUS EMS .....                                      | 18    |
| FIG. BB | — AUXILIARY SAFETY SHUTDOWN INPUT .....  | 18    |
| FIG. CC | — EVAPORATOR WATER PUMP INTERLOCK OR FLOW SWITCH .....   | 18    |
| FIG. DD | — EXCESS PURGE WARNING CONTACTS .....  | 19    |

TO ENERGY MANAGEMENT SYSTEM FROM CHILLER

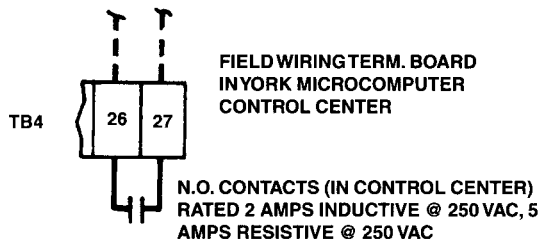
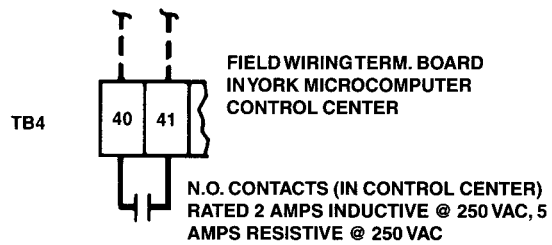

**FIG. A - REMOTE MODE READY TO START CONTACTS**

**FIG. A—REMOTE MODE READY TO START CONTACTS—**

When closed, these contacts signify the following: (1) The MicroComputer Control Center is in "remote" operating mode, allowing for energy management system or remote start/stop control (Fig. E); (2) All Chiller safety cutout controls are in the normal position, so they will allow the Chiller unit to start; (3) All Chiller cycling cutout controls are in the normal position, so they will allow the unit to start; (4) The MicroComputer Control Center "compressor" switch is in the "run" position; (5) The 30 minute anti-recycle timer has timed out (10 minute anti-recycle after 5th successive restart if equipped with VSD). A closure of the Remote Mode Ready to Start Contacts then signifies that the unit shall start when the Energy Management System maintains the Remote Stop Contact (Fig. E) open and momentarily closes the Remote Start Contact (Fig. E). When the Remote Mode Ready to Start Contacts close, the MicroComputer Control Center will display the following message "SYSTEM READY TO START."

TO ENERGY MANAGEMENT SYSTEM FROM CHILLER

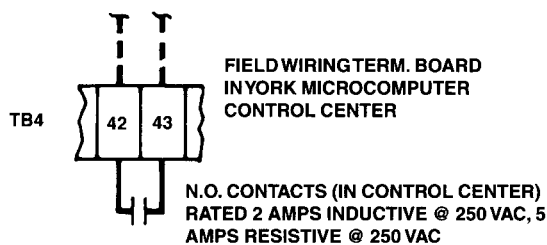

**FIG. B - CYCLING SHUTDOWN CONTACTS**

**FIG. B—CYCLING SHUTDOWN CONTACTS—**

When closed, these contacts signify the unit is not permitted to start due to one or more of the following occurrences: (1) The leaving chilled liquid temperature has dropped 4°F below setpoint; (2) The compressor pre-rotation vane motor switch is open and thus the PRVs are not in the closed starting position; (3) The chilled water pump interlock or flow switch(es) contacts are open—see "Field Connection" wiring diagram, Form 160.48-PA17 (Solid State Starter), 160.48-PA18 (Electro-Mechanical Starter) or Form 160.48-PA15 (VSD); (4) The Remote/Local Cycling Devices Contacts are open—see Fig. F; (5) The Multi-Unit Sequence contacts are open—See Fig. G; (6) The micro board 5VDC supply is less than 4VDC (Power Failure); (7) The compressor motor/heater control relay 1R in the panel has dropped out due to low 115 VAC supply voltage (AC Undervoltage); (8) The solid state starter AC input voltage falls below the cut-out value (Low Line Voltage) for 20 seconds (solid state starter units only); (9) A 115 VAC supply power failure occurred when the Chiller was off with the "Auto Restart After Power Failure" programming jumper installed on the micro board—See Fig. R; (10) The oil temperature fell below 55°F and has not yet risen above 71°F;—See Fig. R; (11) Compressor motor controller shutdown. See Form 160.48-O1 for all VSD cycling shutdowns which are displayed in place of this when equipped with VSD. Upon closure of all contacts above, the unit will automatically restart. When the Cycling Shutdown Contacts are closed, the MicroComputer Control Center will display the following message: "SYSTEM SHUTDOWN—PRESS STATUS," or "VSD SHUTDOWN—PRESS STATUS" if equipped with VSD. Upon pressing "STATUS" key, the status message consists of the day and time of shutdown plus cause of shutdown. Cycling Shutdown Contacts function in all operating modes.

TO ENERGY MANAGEMENT SYSTEM FROM CHILLER

**FIG. C—SAFETY SHUTDOWN CONTACTS**

**FIG. C—SAFETY SHUTDOWN CONTACTS**—When closed, these contacts signify the unit is not permitted to start due to one or more of the following safety controls: low oil pressure, high oil pressure, high condenser pressure, low evaporator pressure, high oil temperature, high discharge temperature (see Form 160.48-O1 for all safety shutdowns displayed when equipped with a VSD), and power failure when the “Auto Restart After Power Failure” programming jumper is NOT installed on the microboard (Fig. R) which implies that the Chiller requires “manual restart after power failure.” On solid state starter units only, when jumper JP5 (marked “CURR UNBAL”) is installed in the micro board, three phase current unbalance protection is provided. A safety shutdown occurs (following a 45 second by-pass at start up) whenever the % FLA readout exceeds 80% for 45 seconds continuously and the % unbalance is  $\geq 30\%$ . When all safety controls are satisfied, and the MicroComputer Control Center “compressor” switch has been manually “reset” and returned to the “run” position the unit may be restarted, if in “remote” mode, via the Remote Start Contacts (Fig. E) or if in “local” mode by pressing keypad compressor “start” switch.

A closure of the Safety Shutdown Contacts means that an operator must manually reset and restart the unit. When the Safety Shutdown Contacts are closed, the MicroComputer Control Center will display the following message: “SYSTEM SHUTDOWN—PRESS STATUS,” or “VSD SHUTDOWN—PRESS STATUS” if VSD related safety shutdown has occurred—when equipped with VSD. Upon pressing “status” key, the status message consists of the day and time of shutdown plus cause of shutdown. Safety Shutdown Contacts function in all operating modes, remote, local and service.

TO ENERGY MANAGEMENT SYSTEM FROM CHILLER

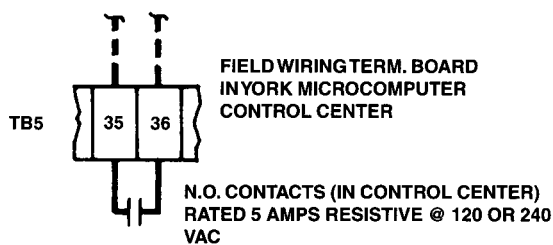
**FIG. D—RUN CONTACTS**

**FIG. D—RUN CONTACTS**—When closed, these contacts signify that the unit is operating. The MicroComputer Control Center will display:

- (1) “SYSTEM RUN—LEAVING TEMP. CONTROL”—Message displayed while the unit is running; indicating that the compressor pre-rotation vanes (capacity control) are being controlled by the leaving chilled liquid temperature setpoint.
- (2) “SYSTEM RUN—CURRENT LIMIT IN EFFECT”—Message displayed while the unit is running; indicating that the compressor pre-rotation vanes and/or motor speed, if equipped with VSD, (capacity control) are being controlled by the motor current limit value to operate the unit at reduced capacity.

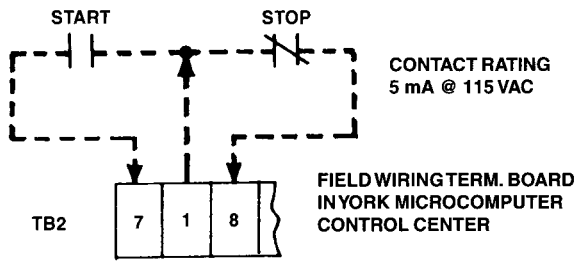

**FIG. E—REMOTE START-STOP CONTACTS FROM ENERGY MANAGEMENT SYSTEM**

**FIG. E—REMOTE START AND STOP CONTACTS FROM ENERGY MANAGEMENT SYSTEM**—When the MicroComputer Control Center is in the “remote” operating mode and the “compressor” switch is in the “run” position, with the Remote Stop Contacts open, and the Remote Mode Ready to Start Contacts closed ( Fig. A), the unit will start via a momentary or maintained closure of the Remote Start Contacts. A subsequent closure of the Energy Management System Remote Stop Contacts causes the unit to shut down. The MicroComputer Control Center will display the following message: “SYSTEM SHUTDOWN—PRESS STATUS.” Upon pressing “status” key “REMOTE STOP” message will be displayed when the Energy Management System Remote Stop Contacts has commanded the unit to shut down.

It is recommended that maintained contacts be used for both START and STOP.

When terminals **7**, **1** and **8** on terminal board TB2 are not connected to an Energy Management System, they may be connected to a Remote Start-Stop station (see Fig. X).

*Note*—Even when the Chiller unit is applied with Remote Start-Stop (when the Control Center is in the “remote operating mode), an EMERGENCY STOP by an operator or others can STOP the compressor from the MicroComputer Control Center and prevent the unit from restarting. However, the operator cannot locally start the compressor using “compressor” start switch, when the control center is in the “remote” operating mode.

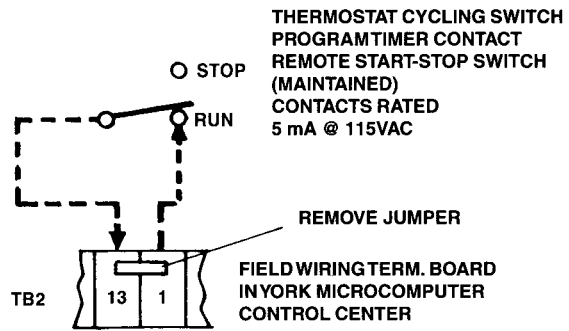

**FIG. F—REMOTE/LOCAL CYCLING DEVICES**

**FIG. F—REMOTE/LOCAL CYCLING DEVICES**—The closure of an automatic reset device across this input will permit the unit to operate in all operating modes. Conversely, an opening of the device contacts will inhibit the unit from operating; the MicroComputer Control Center will then display the following message: “SYSTEM SHUTDOWN—PRESS STATUS.” Upon pressing “status” key, the status message will read day and time of shutdown; “DAY XX:XX AM (DAY MONTH XXXX [military time] if equipped with VSD)—SYSTEM CYCLING—AUTO START.”

*Note*—The MicroComputer Control Center contains a seven day time clock to select daily schedule Start/Stop times (Sunday through Saturday including one or more holidays in week) up to one full week at a time. So automatic start and stop of the Chiller unit on a daily basis, at predetermined times, can be programmed as a standard feature; an additional program timer is not required for this function.

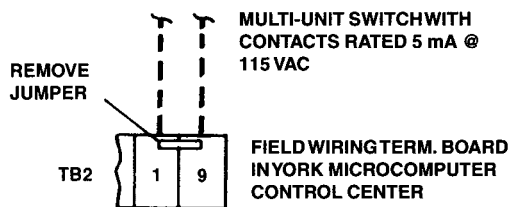

**FIG. G—MULTI-UNIT SEQUENCE**

**FIG. G—MULTI-UNIT SEQUENCE**—For multiple Chiller installation application, Multi-Unit Sequence contacts are available to start and stop each unit. The maintained closure of a device contacts across terminals **1** and **9** will permit the unit to operate in all of the operating modes with the “compressor” switch in the “run” position. Conversely, an opening of the device contacts will inhibit the unit from operating; the MicroComputer Control Center will then display the following message: “SYSTEM SHUTDOWN—PRESS STATUS.” Upon pressing “status” key, the status message will read day and time of shutdown: “DAY XX:XX AM (DAY MONTH XXXX [military time] if equipped with VSD)—MULTI-CHILLER UNIT CYCLING—AUTO START.” An accessory sequence control kit for two, three or four units is available from York—See Fig. J for Two Unit Sequence Control kit.

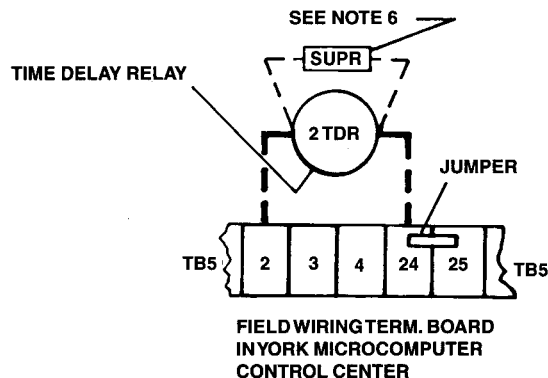
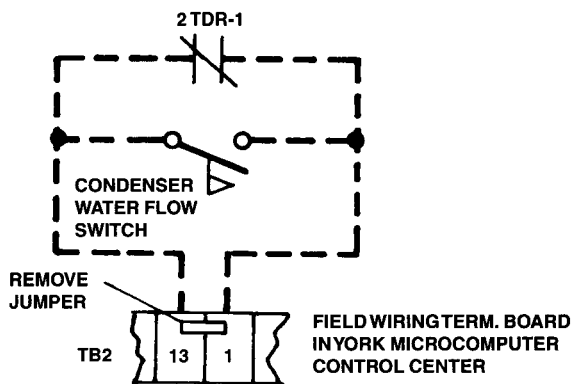
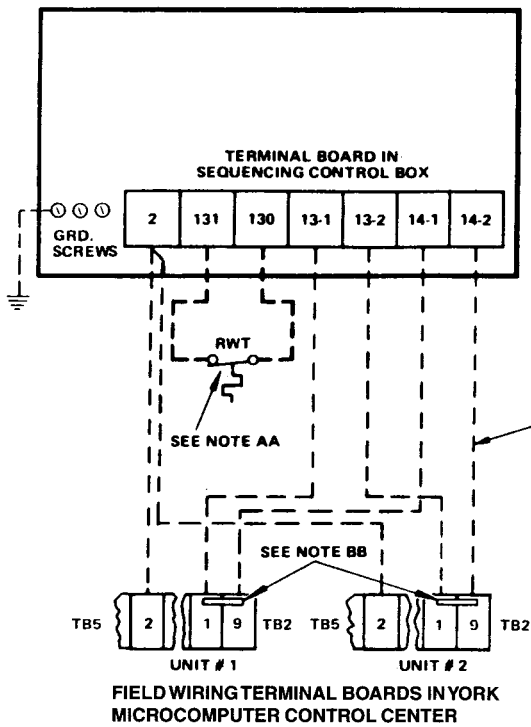

**FIG. H—CONDENSER WATER FLOW INTERLOCK (SEE NOTES 6 & 12)**

**FIG. H—CONDENSER WATER FLOW INTERLOCK**—If desired, a condenser water flow interlock can be applied. Flow switch—McDonnell type FS8W, max. 150 psi (York Part No. 024-15793) available at additional cost. Time delay relay (2TDR) Syracuse Electronics Corp., Series TCR-02311 or equal; 115 VAC, 50/60 hz, 2 watts, SPDT contacts rated 5 amps resistive, 0.6 to 60 second adjustable on delay, octal plug-in mounting. Set for appropriate delay.

When condenser water is flowing, the flow switch contact will close. Opening of the condenser water flow switch contacts will cause unit shutdown. The MicroComputer Control Center will display the following message: “SYSTEM SHUTDOWN—PRESS STATUS.” Upon pressing “status” key, the status message will read the day and time of shutdown, “DAY XX:XX AM (DAY MONTH XXXX [military time] if equipped with VSD)—SYSTEM CYCLING—AUTO START.”

**FIELD CONNECTION DIAGRAM**



**ELEMENTARY DIAGRAM**

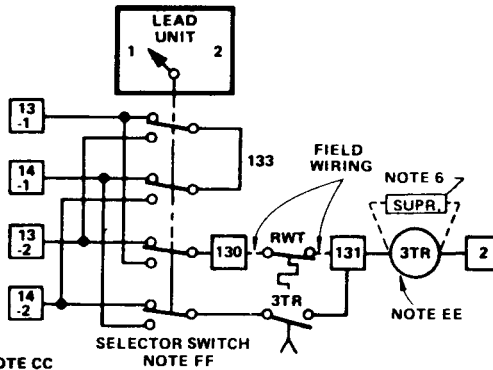

- NOTES:**  
 AA. RWT - RETURN WATER THERMOSTAT BY YORK.  
 BB. REMOVE JUMPER CONNECTING TERMINAL 1 TO 9 AT TERMINAL BOARD MOUNTED IN CHILLER CONTROL CENTERS.  
 CC. ALL REMOTE WIRING (BY OTHERS) TO BE #14 AWG COPPER CLASS 1 N.E.C. CONTROL WIRE.  
 DD. ALL CONTACTS HAVE A MAXIMUM RATING OF 125 VA @ 125 VAC 50/60 HZ.  
 EE. 3TR - TIME DELAY RELAY, 100 SEC., "ON" DELAY.  
 FF. 4 POLE, DOUBLE THROW SNAP SWITCH (TOGGLE).

**TWO UNIT SEQUENCE CONTROL—PARALLEL OR SERIES WATER FLOW—LEAD SELECTOR AND CYCLING THERMOSTAT (NOTES 2, 6, 8, 10 & 11)**

**FIG. J—TWO UNIT SEQUENCE CONTROL**

**FIG. J—TWO UNIT SEQUENCE CONTROL**—Provides that cycling thermostat RWT will automatically cycle either #1 or #2 unit. Timer 3TR is an additional feature which prevents simultaneous starting of lead and lag unit following a power failure and eliminates nuisance starting of lag unit due to periodic fluctuations in temperature. For two unit sequence control kit, order York accessory Kit No. 466-61597T for controls as specified with NEMA I enclosure.

See Form **150.40-NM2.2** for Installation and Operation Instructions. RWT has 20°F to 80°F range with adjustable differential of 3-1/2 to 14°F; 6 ft. of capillary with 3/8" x 5" bulb and 1/2" NPT brass well (maximum liquid DWP 300 psig). The thermostat is drawn to indicate its operation closes on rise. A 1/2" pipe coupling in the return chilled water line from the building must be furnished (by others) for RWT control well.

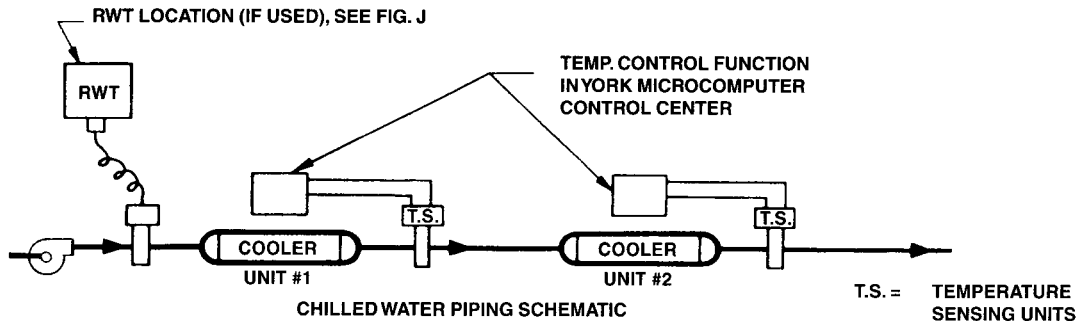

**FIG. K—MULTIPLE UNITS (TWO)—SERIES OPERATION (NOTES 8 & 11)**

**FIG. K—MULTIPLE CHILLER UNITS (TWO)—SERIES OPERATION**—The supply chilled water temperature to the building is normally determined by the "chilled liquid temp." setpoint for Unit #2. When lead selector position of sequence control kit

(Fig. J) is Unit #1, the supply chilled water temperature to the building will be the temperature control setpoint on Unit #1 MicroComputer Control Center. If a lower temperature is desired, reprogram the "chilled liquid temp." setpoint for Unit #1.

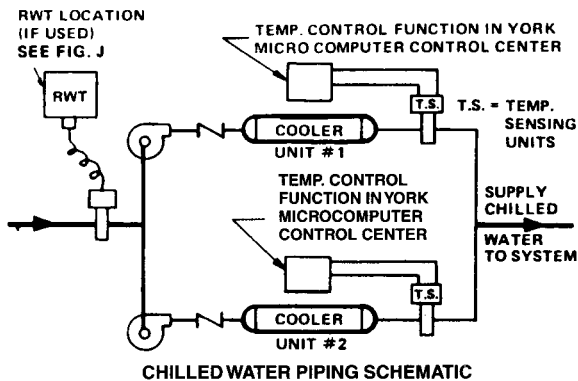

**MULTIPLE UNITS—PARALLEL OPERATION:**  
 IN THIS ARRANGEMENT, THE INDIVIDUAL CHILLED WATER PUMP IS STOPPED WHEN THE ONE UNIT IS SHUT DOWN AT APPROXIMATELY 40% SYSTEM LOAD. LEAVING CHILLED WATER TEMPERATURE IS CONSTANT (+/- 1/2 F) AT ALL LOADS. (NOTES 8 & 11)

**FIG. L—MULTIPLE CHILLER UNITS (TWO)—PARALLEL OPERATION—INDIVIDUAL UNIT PUMPS**

**FIG. L—MULTIPLE UNITS (TWO)—PARALLEL OPERATION—INDIVIDUAL UNIT PUMPS**—This piping arrangement is the same as Fig. M, except that the chilled water pumps associated with each cooler (evaporator) are cycled on and off with the unit. This results in reduced chilled water flow rates whenever a single unit can handle the cooling load. Because no chilled water flows through the inoperative unit, the mixed water temperature peculiar to using a single pump is avoided. When one unit is cut-out by the sequence control (Fig. J) the temperature of the supply chilled water does not change.

**TO ELECTRO-MECHANICAL STARTER  
 MANUAL RESET OVERLOAD AND/OR  
 SAFETY DEVICES WITH CONTACTS  
 RATED 5 mA @ 115 VAC**

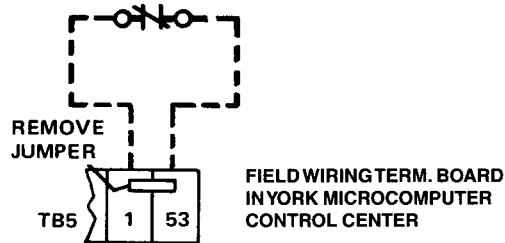

**FIG. N—ELECTRO-MECHANICAL STARTER MANUAL RESET OVERLOADS (2300 TO 4160 VOLTS U.L. OR C.S.A. APPROVED UNITS ONLY)**

**FIG. N—ELECTRO-MECHANICAL STARTER MANUAL RESET OVERLOADS**—Terminals are available for connection of the manual reset overloads and/or safety devices in the high voltage electro-mechanical starter for U. L. or C.S.A. approved units having 2300 to 4160 volt motors. See Remote Motor Starter (E-M) specifications, Product Drawing Form 160.45-PA5.1. An opening of the contacts causes the MicroComputer Control Center to display: "SYSTEM SHUT-DOWN—PRESS STATUS." Upon pressing "status" key, the status message will read the day and time of shutdown, "DAY XX:XX AM—MOTOR CONTROLLER—EXT. RESET." To restart the unit, reset the external device in the electro-mechanical starter that caused the shutdown. Then the unit will automatically restart.

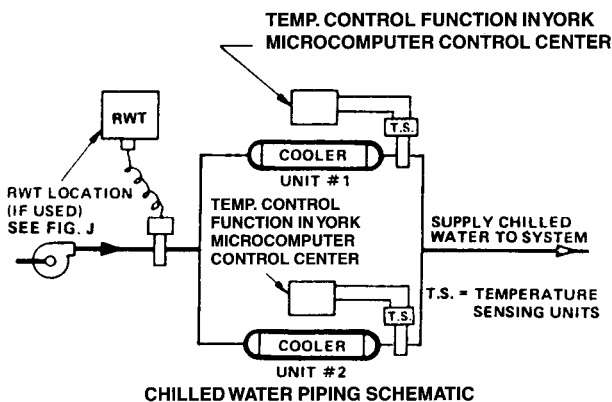

**MULTIPLE UNITS—PARALLEL OPERATION:**  
 IN THIS ARRANGEMENT, WHEN ONE UNIT IS SHUT-DOWN AT APPROXIMATELY 40% LOAD, THE CHILLED WATER TEMPERATURE SUPPLY TO THE SYSTEM RISES TO THE MIXED TEMPERATURE OF THE CHILLED WATER LEAVING BOTH UNITS, FOR ALL LOADS DOWN TO MINIMUM CAPACITY. LEAVING CHILLED WATER TEMPERATURE IS CONSTANT (+/- 1/2°F) AS LONG AS BOTH UNITS ARE IN OPERATION. (NOTES 8 & 11)

**FIG. M—MULTIPLE UNITS (TWO)—PARALLEL OPERATION—SINGLE CHILLED WATER PUMP**

**FIG. M—MULTIPLE UNITS (TWO)—PARALLEL OPERATION—SINGLE CHILLED WATER PUMP**—For this piping arrangement, each Chiller's water sensor is located in its own leaving water nozzle. This produces a constant "mixed" chilled water temperature when both units are operating. When either unit is cycled off by the sequence control (Fig. J), mixed chilled water temperature will rise as a result of uncooled return water flowing through the inoperative unit. For individual unit chilled water pump piping, refer to Fig L.

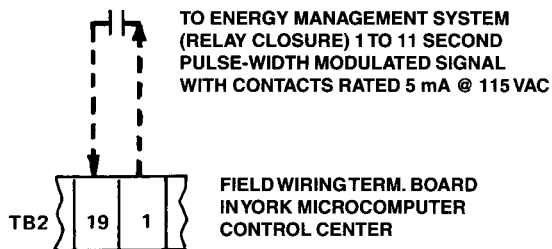

**FIG. P—REMOTE LEAVING CHILLED WATER TEMPERATURE SETPOINT WITH PWM SIGNAL**

**FIG. P—REMOTE LEAVING CHILLED WATER TEMPERATURE SETPOINT WITH PWM SIGNAL**—The MicroComputer Control Center can be programmed via panel “remote reset temp. range” setpoint for a 10°F or 20°F leaving chilled liquid temperature reset range. Then automatic remote temperature setpoint is accomplished by supplying (by others) a 1 to 11 second pulse-width modulated signal across terminals **1** and **19** on the digital input board (field wiring terminal board TB2) in the MicroComputer Control Center. The input signal will only be accepted when the MicroComputer Control Center is in the “remote” operating mode—see Fig. A. Unit capacity control is from the leaving chilled water temperature, providing the compressor motor current is below the current limit setpoint. A one second pulse corresponds to zero deg. F offset and therefore at the programmed leaving chilled liquid temperature setpoint. An eleven second pulse corresponds to maximum offset (10 °F or 20 °F as programmed) above the programmed setpoint. The amount of offset from 1 to 11 seconds varies linearly with pulse-width. For example, a 3 second pulse applied (across terminals **1** and **19**) to the unit programmed for 45°F leaving chilled water temperature setpoint and 20°F “remote reset temp. range,” the new setpoint would be:

Temp. Offset —

$$\text{Deg. F offset} = \frac{(\text{pulse-width} - 1) (\text{remote reset temp. range})}{10}$$

$$\text{Deg. F offset} = \frac{(3 - 1) (20)}{10} = 4^\circ\text{F}$$

Setpoint = keypad entered setpoint + °F offset

Thus the new leaving chilled water temperature control point is 45°F + 4°F = 49°F.

The maximum rate at which the MicroComputer Control Center will accept reset pulses is one pulse each 60 seconds. If a second reset pulse is not received within 30 minutes of the first pulse, the temperature setpoint reverts to the base setpoint (with no offset). If the unit has a VSD refer to Note 15.

Figure P can be applied in conjunction with Fig. Q, thus providing the capability of remotely controlling both leaving chilled liquid temperature setting AND motor current limit setting simultaneously, if so desired.

For remote temperature setpoint via a 4 to 20 mA D.C. current signal, a 0 to 10 volt D.C. signal, or a single contact closure, refer to Fig. V.

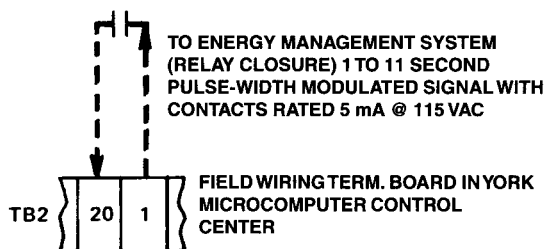

**FIG. Q—REMOTE CURRENT LIMIT SETPOINT WITH PWM SIGNAL**

**FIG. Q—REMOTE CURRENT LIMIT SETPOINT WITH PWM SIGNAL**—Remote current limit reset is accomplished by supplying (by others) a 1 to 11 second pulse-width modulated signal across terminals **1** and **20** on the digital input board (field wiring terminal board TB2) in the MicroComputer Control Center. The input signal will only be accepted when the MicroComputer Control Center is in the “remote” operating mode—see Fig. A. Chiller capacity control is from the leaving chilled water temperature, providing the current limit setpoint is satisfied. When the compressor motor current exceeds the current limit setpoint, it will override the temperature control system to reduce Chiller capacity. A one second pulse corresponds to 100% full load amperes and an eleven second pulse corresponds to 40% of full load amperes. The current limit setpoint varies linearly from 100% to 40% as the pulse-width changes from 1 to 11 seconds. For example, for a 5 second pulse applied across terminals **1** and **20** of TB2, the current limit setpoint would be as follows:

Remote Current Limit —

$$\text{Setpoint} = 100\% - (\text{pulse-width in seconds} - 1) 6\%$$

$$\text{Setpoint} = 100\% - (5 - 1) 6\% = 100\% - 24\% = 76\%$$

The maximum rate at which the MicroComputer Control Center will accept remote current limit setpoint pulses is one pulse each 60 seconds.

Following a remote setpoint pulse, the current limit setpoint changes to the value corresponding to the pulse-width. If a second reset pulse is not received within 30 minutes of the first pulse, the current setpoint reverts to the programmed current limit setpoint. If the MicroComputer Control Center “Pull-down Demand Limit” (standard available function) has been programmed and the unit was started and has run less than the Pull-down Demand Limit timer setting, then the unit will be current limited by the Pull-down Demand Limit. The Pull-down Demand Limit will automatically transfer control of current limit function to “remote” at the end of its programmed timed cycle with keyswitch in “remote” mode.

Figure Q can be applied in conjunction with Fig. P, thus providing the capability of remotely controlling both motor current limit setting AND leaving chilled water temperature setting simultaneously, if so desired.

For remote current limit setpoint via a 4 to 20 mA D.C. current signal, a 0 to 10 volt D.C. signal, or a single contact closure, refer to Fig. V.

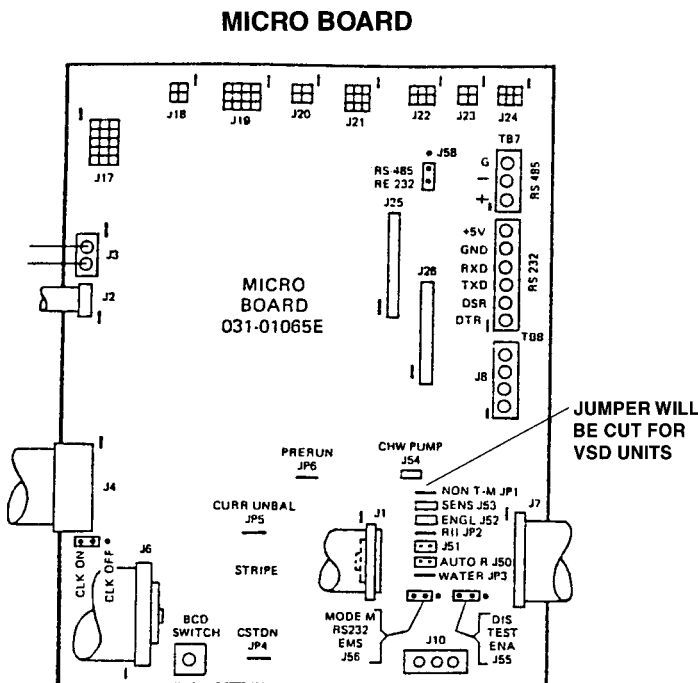

**FIG. R—MICRO BOARD JUMPERS FOR AUTO/MANUAL RESTART AFTER POWER FAILURE OR ENGLISH/METRIC DISPLAY UNITS**

**FIG. R—MICRO BOARD JUMPERS FOR AUTO/MANUAL RESTART OR ENGLISH/METRIC DISPLAY UNITS**—This figure shows the location of two jumpers, “Auto Restart” and “English,” on the Micro Board which can convert the MicroComputer Control Center functions. The Micro Board is on the rear panel located directly behind the MicroComputer Control Center key locked door and hinged panel; refer to the Connection Diagram page of Wiring Diagram, Form 160.48-PA20 (with Solid State Starter) or 160.48-PA19 (with electro-mechanical starter) or 160.48PA21 (with VSD). For orientation purposes with the Connection Diagram, see Fig. R.

1. Auto Restart Jumper—The MicroComputer Control Center is furnished for Manual Restart After Power Failure as a standard function. The Control Center can be field changed to AUTOMATIC restart after a power failure, if the MANUAL Restart feature is not desired. Simply remove jumper from provided bag of parts, and plug in the “Auto Restart” programming JUMPER (Auto R.) on the Micro Board.
2. English Jumper—The MicroComputer Control Center can present the “display” in English or Metric System of Units. For English units, temperature display is in degree Fahrenheit (°F) and absolute pressure in pounds per square inch (psia). For Metric units, temperature display is in degree Celsius (°C) and pressure in Kilo-Pascals (KPa). When the Metric system of units is desired, the Micro Board JUMPER (“English”), shown in Fig. R, is removed from the J52 terminals.

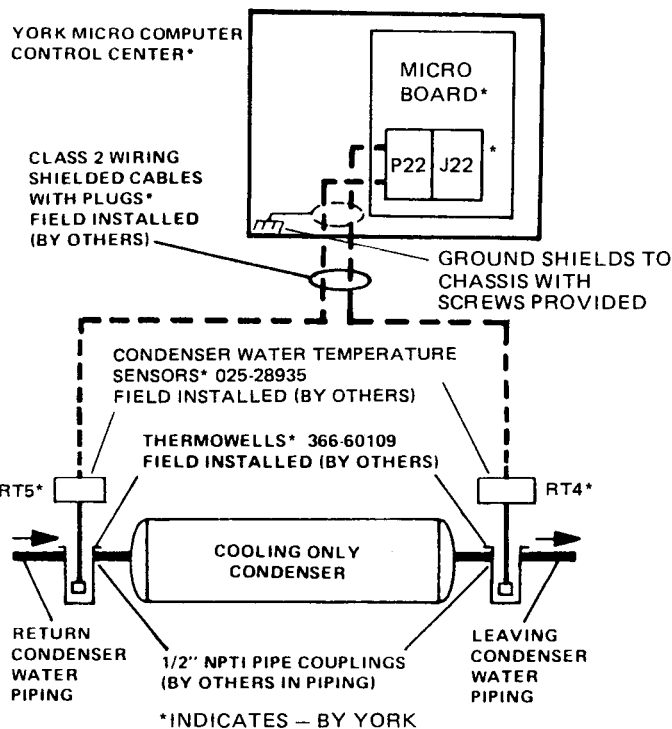

**FIG. S—CONDENSER WATER TEMPERATURE SENSORS (KIT)**

**FIG. S—CONDENSER WATER TEMPERATURE SENSORS**—Optional, at additional cost, condenser water temperature sensors can be used in conjunction with the York MicroComputer Control Center to indicate water temperatures in and out of the condenser. When the control center “Condenser Liquid Temps.” display key is pressed, the front panel display will then produce the following message: “COND. LEAVING = XXX.X °F, RETURN = XXX.X °F” for operator convenience. Instead of °F, the control center can display °C—see Fig. R for English/Metric jumper.

Option Kit includes: two condenser water temperatures sensors (thermistors) RT4 & RT5 (025-28935), two thermowells (366-60109) and necessary (26 ft. each) shielded cable wire with plug connector ends to run (by others) between the condenser sensor/thermowells and control center, plus four wire clamps & hardware for supporting cables. Order York Accessory Kit No. 375-01738-000; all shipped loose for field installation by others. Control wiring is N.E.C. Class 2, so conduit is not required. Sensor thermowells are copper, suitable for 150 psig D.W.P. For heat recovery units with double bundle condenser, the condenser water temperature sensors may be applied to the hot water circuit, instead of the tower water circuit, if desired; the control center can accept only two input sensors for condenser water temperature. Pipe couplings (by others) are required in the water piping located on the upper half of pipe. For details refer to Installation Instructions, Form 160.46-N2.4. When the kit is not used, thermometers should be provided (by others) in the water piping to measure leaving and return condenser water temperatures for performance monitoring. The MicroComputer Control Center is furnished with “chilled liquid temperatures” as a standard feature, with temperature sensors factory installed in chilled liquid entering and leaving nozzles and factory wired to the control center.

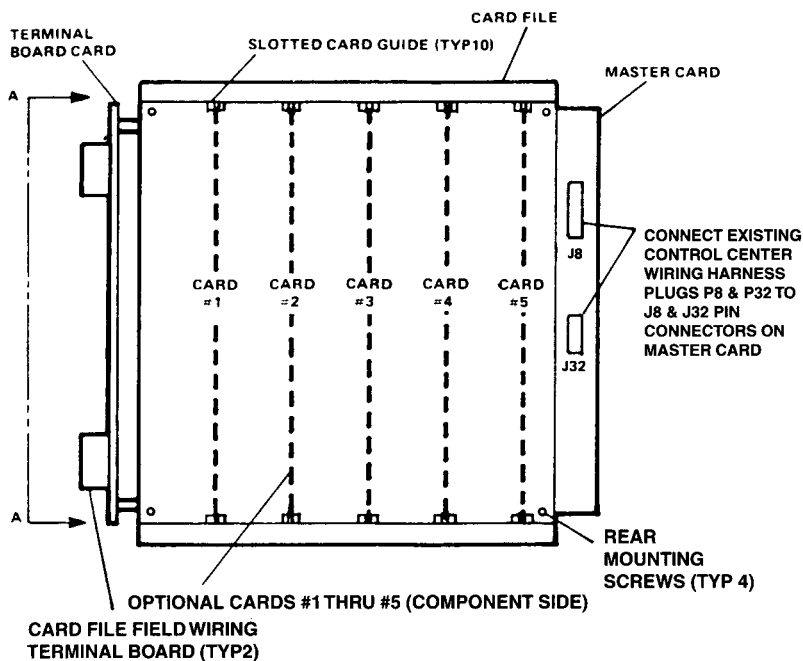

DETAIL—CARD FILE (FRONT VIEW)

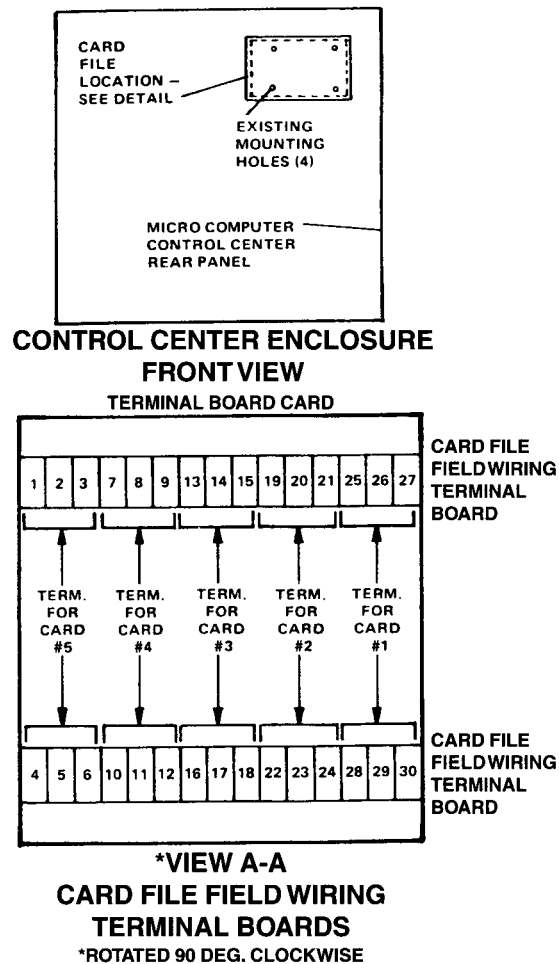

FIG. U—CARD FILE

**FIG. U—CARD FILE**—Designed-in flexibility of the MicroComputer Control Center allows the unit to be tailored for the application—for example, using a 4 to 20 mA D.C. current signal instead of a 1 to 11 second pulse-width modulated signal, for Remote Current Limit Setpoint. There are a number of such options available to the user. The Card File assembly provides the basic control system building block for optional features (when desired). The Card File function is to serve as a mounting medium for optional (at additional cost) electronic control printed circuit boards (“cards”). The Card File is a field installed assembly which includes slotted card guides, a field wiring terminal board card having 30 terminals, and a master card having connectors for option cards. One Card File can hold up to five option cards (at additional cost). The accessible field wiring terminal boards, located on the left end of the Card File assembly, provide six field connection terminals for each option card—See View A-A. For example, option card #1 would use field wiring terminals numbered 25 thru 30. The MicroComputer Control Center provides the 12 volt D.C. unregulated power to the master card; simply push-on connector plugs P8 & P32 from the control center existing wiring harnesses, to the corresponding master card J8 & J32 pin connectors. The Card File assembly (6" W x 8-3/4" L x 6-1/2" D overall) is easily field installed (by

others) within the control center enclosure at the “Card File” location, on the rear panel, using four standoff mounts, screws and lockwashers (factory furnished)—see Card File Installation Instructions, Form 160.45-N2.2, for more details. At additional cost, order York Accessory Part No. 031-00827-000 for the Card File Assembly (with mounting hardware); shipped loose for field installation (by others). Option cards #1 thru #5 are NOT included with the Card File Assembly (refer to Figs. V and W).

Front loading option cards (#1 thru #5) are field mounted into the Card File via slotted slide card guides, for easy push-in installation and plug connection to master card. Each option card has a keyway to mate with the corresponding key connector on the master card; the option card (#1 thru #5) can only be mounted in the proper Card File guides and in the correct position.

Option cards #1 and #2 provide the user with the capability of remotely controlling both motor current limit setting AND leaving chilled water temperature setting simultaneously, if so desired. Refer to Figs. V and W.

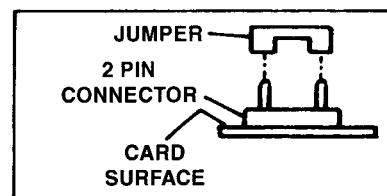
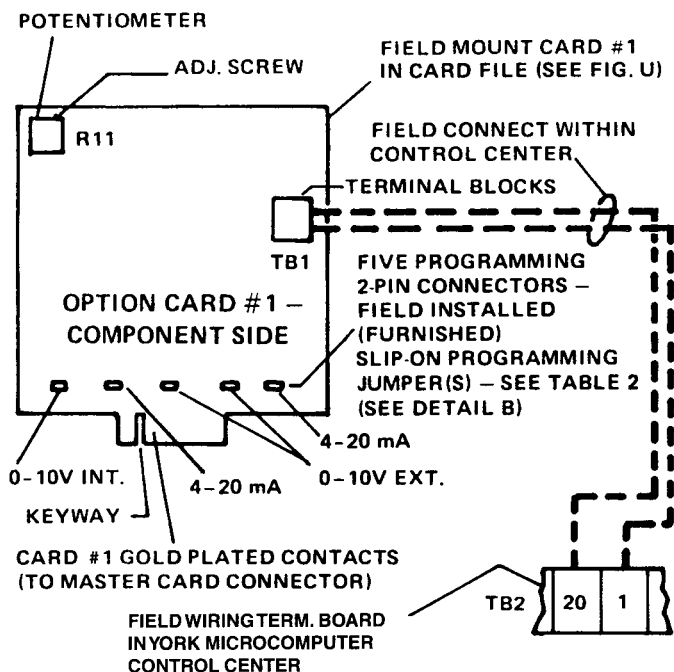

DETAIL B - JUMPER END VIEW

TABLE 2—JUMPER POSITION FOR CARD #1 PROGRAMMING MODE

| SEE<br>DETAIL | TYPE<br>REMOTE<br>INPUT SIGNAL | PROGRAMMING MODE<br>PIN CONNECTORS |            |              |              |            |
|---------------|--------------------------------|------------------------------------|------------|--------------|--------------|------------|
|               |                                | 0-10V<br>INT                       | 4-20<br>mA | 0-10V<br>EXT | 0-10V<br>EXT | 4-20<br>mA |
| 1             | 4 TO 20 mA                     | —                                  | ON         | —            | —            | ON         |
| 2             | 0 TO 10 VOLTS                  | —                                  | —          | ON           | ON           | —          |
| 3             | CONTACT CLOSURE*               | ON                                 | —          | —            | —            | —          |

\*ONLY ONE JUMPER IS USED

FIG. V—REMOTE CURRENT LIMIT SETPOINT—OPTION CARD #1

**FIG. V—REMOTE CURRENT LIMIT SETPOINT OPTION CARD #1**—A standard feature of the MicroComputer Control Center is to accept a 1 to 11 second pulse-width modulated (PWM) signal (by others) for remote current limit setpoint. Should the application require an input signal of 4 to 20 mA D.C., or 0 to 10 volts D.C., or a single contact closure for one discrete remote current limit setpoint—instead of a PWM signal—then option card #1 is required in conjunction with the Card File (see Fig. U). The input signal (by others) can be from an energy management system, etc. The MicroComputer Control Center will only accept the input signal when the “remote” mode is selected—See Fig. A. When option card #1 is used, Fig. Q, for PWM signal, cannot be applied. Chiller unit capacity control is from the leaving chilled water temperature, providing the current limit setpoint is not reached. When compressor motor current exceeds the current limit setpoint, it will override the temperature control system to reduce Chiller unit capacity.

Three input signal choices are available using option card #1. The user first determines which one is desired: (1) 4 to 20 mA D.C., (2) 0 to 10 volts D.C., or (3) single contact closure. Two slip-on programming mode jumpers are furnished with card #1. Simply place the program jumper(s) on the 2-pin connectors (see Detail B) according to the positions indicated by Table 2. Note only one jumper is used if the contact closure mode was chosen.

The optional Card File (Fig. U) must have been previously field installed (by others) in the MicroComputer Control Center, because it serves as the mounting medium for card #1. Field install (by others) card #1 by just sliding it into the slotted card guides of the Card File; connect the wiring harness (by others) from card #1 terminal block (TB1) to control center terminal board (TB2) as shown.

Input signal wiring is field connected (by others) to the Card File field wiring terminals, as shown in Detail 1, 2 or 3 (see Page 19). Select the detail that agrees with how program jumper(s) were positioned on card #1. For more details on Card File field wiring terminal board, refer to Fig. U—see View A-A.

The timer circuit on card #1 will permit the unit to begin responding to an input signal change within 150 seconds after the signal is received. Following a remote setpoint signal, the current limit setpoint changes to the value corresponding to the signal (see Details 1, 2 or 3). When the remote setpoint signal is removed, the setpoint reverts to the programmed current limit setpoint following a 30 minute built-in time delay. If the MicroComputer Control Center “Pull-down Demand Limit” (standard available function) has been programmed and the unit was started and has run less than the Pull-down Demand Limit timer setting, then the unit will be current limited by the Pull-down Demand Limit. The Pull-down Demand Limit will automatically transfer control of current limit function to “remote” at the end of its programmed timed cycle with panel in “remote” operating mode.

Order, at additional cost, York Remote Current Limit Setpoint Option Card, Part No. 031-00814-000; shipped loose for field installation (by others). The optional Card File (Fig. U) is REQUIRED if card #1 is ordered. When Remote Leaving Chilled Water Temperature Control Setpoint option card #2 is also ordered, cards #1 AND #2 are required, but only ONE Card File is ordered. Refer to card #1 Installation instructions, Form 160.45-N2.3.

Option card #1 in Fig. V can be applied in conjunction with Fig. W (option card #2), thus providing the capability of remotely controlling both motor current limit setting AND leaving chilled water temperature setting simultaneously, if so desired.

See Page 14 for Details 1, 2 & 3.

**DETAIL 1**—Remote Current Limit Setpoint is accomplished by supplying a 4 to 20 mA D.C. input current signal (by others) across terminals **28** and **30** on the Card File field wiring terminal board (see Fig. U). Option card #1 program jumper positions must be per Table 2. A 4 mA signal corresponds to 100% full load amperes and a 20 mA signal corresponds to 40% of full load amperes. The current limit setpoint varies linearly from 100% to 40%, as the current changes from 4 to 20 mA. For example, 8 mA applied across terminals **28** and **30** of the Card File, the current limit setpoint would be as follows:

Remote Current Limit—

$$\text{Setpoint} = 100\% - (\text{mA signal} - 4) 3.75\%$$

$$\text{Setpoint} = 100\% - (8 - 4) 3.75\% = 100\% - 15\% = 85\%$$

The maximum rate at which the MicroComputer Control Center will accept remote current limit setpoint mA signal is once each 150 seconds.

For remote current limit setpoint via a 0 to 10 volt D.C. signal—see Detail 2, or a single contact closure—see Detail 3. Refer to Fig. Q for pulse-width modulated signal.

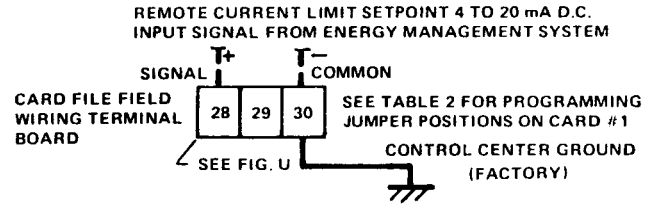

**DETAIL 1—4 to 20 mA D.C. INPUT CURRENT SIGNAL CONNECTIONS**

**DETAIL 2**—Remote Current Limit Setpoint is accomplished by supplying a 0 to 10 volt D.C. input voltage signal (by others) across terminals **28** and **30** on the Card File field wiring terminal board (see Fig. U). Option card #1 program jumper positions must be per Table 2. A 0 volt D.C. signal corresponds to 100% of full load amperes. The current limit setpoint varies linearly from 100% to 40% as the voltage changes from 0 to 10 volts D.C. For example, 4 volts D.C. applied across terminals **28** and **30** of the Card File, the current limit setpoint would be as follows:

Remote Current Limit—

$$\text{Setpoint} = 100\% - (\text{D.C. voltage signal}) 6\%$$

$$\text{Setpoint} = 100\% - (4) 6\% = 100\% - 24\% = 76\%$$

The maximum rate at which the MicroComputer Control Center will accept remote current limit setpoint D.C. voltage signal is once each 150 seconds.

For remote current limit setpoint via a 4 to 20 mA D.C. signal—see Detail 1, or a single contact closure—see Detail 3. Refer to Fig. Q for pulse-width modulated signal.

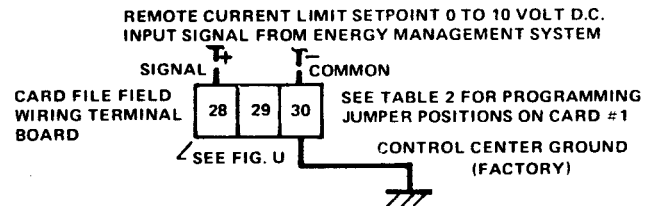

**DETAIL 2—0 TO 10 VOLT D.C. INPUT VOLTAGE SIGNAL CONNECTIONS**

**DETAIL 3**—Remote Current Limit Setpoint is accomplished by supplying a single dry circuit contact closure, 2 milliamperes @ 12 volts (by others) across terminals **25** and **26** on the Card File field wiring terminal board (see Fig. U). Option card #1 program jumper (one) position must be per Table 2. The contact closure provides one discrete remote current limit setpoint corresponding to the % (100 to 40) full load amperes setting (screw adjustable) that has been previously field selected (by others) on card #1 potentiometer (R11)—see top left corner of card #1.

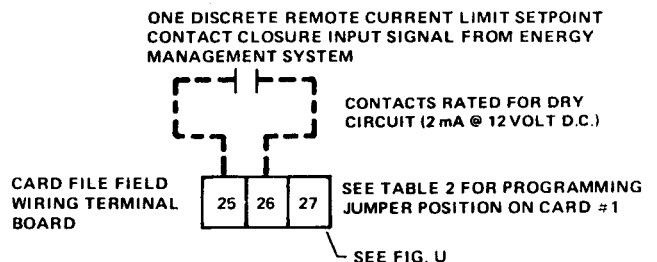

**DETAIL 3—CONTACT CLOSURE INPUT SIGNAL CONNECTIONS**

**FIG. V (Continued)—REMOTE CURRENT LIMIT SETPOINT—OPTION CARD #1**

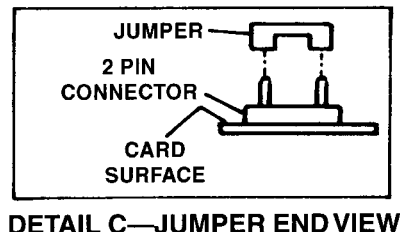
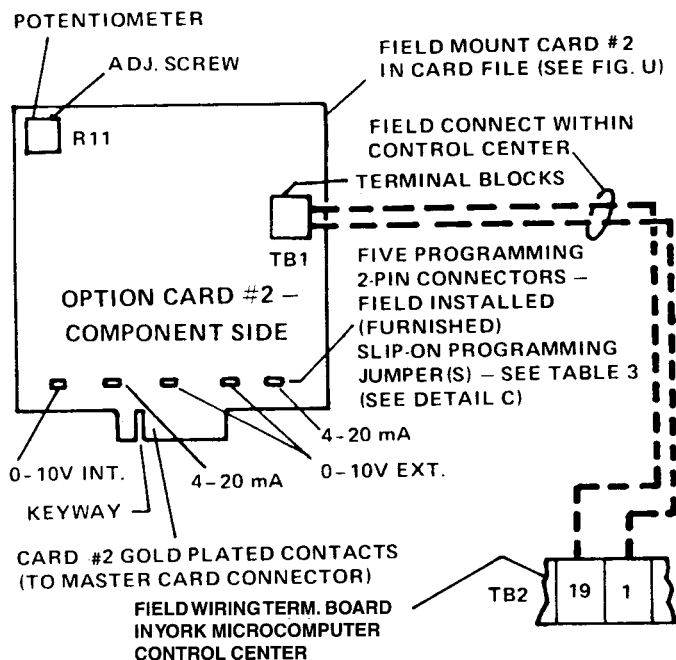

TABLE 3—JUMPER POSITION FOR CARD #2 PROGRAMMING MODE

| SEE DETAIL | TYPE REMOTE INPUT SIGNAL | PROGRAMMING MODE PIN CONNECTORS |         |           |           |         |
|------------|--------------------------|---------------------------------|---------|-----------|-----------|---------|
|            |                          | 0-10V INT                       | 4-20 mA | 0-10V EXT | 0-10V EXT | 4-20 mA |
| 1          | 4 TO 20 mA               | —                               | ON      | —         | —         | ON      |
| 2          | 0 TO 10 VOLTS            | —                               | —       | ON        | ON        | —       |
| 3          | CONTACT CLOSURE*         | ON                              | —       | —         | —         | —       |

\*ONLY ONE JUMPER IS USED

FIG. W—REMOTE LEAVING CHILLED WATER TEMPERATURE SETPOINT OPTION CARD #2

**FIG. W—REMOTE LEAVING CHILLED WATER TEMPERATURE OPTION CARD #2**—A standard feature of the MicroComputer Control Center is to accept a 1 to 11 second pulse-width modulated (PWM) signal (by others) for remote leaving chilled water temperature setpoint. Should the application require an input signal of 4 to 20 mA D.C., or 0 to 10 volts D.C., or a single contact closure for one discrete remote leaving chilled water temperature—instead of a PWM signal—then option card #2 is required in conjunction with the Card File (see Fig. U). The input signal (by others) can be from an energy management system, etc. The MicroComputer Control Center will only accept the input signal when “remote” mode is selected—see Fig. A. When option card #2 is used, Fig. P, for PWM signal, cannot be applied. Unit capacity control is from the leaving chilled water temperature, providing the current limit setpoint is not reached.

The MicroComputer Control Center can be programmed via “Remote Reset Temp. Range” setpoint key for a 10°F or 20°F leaving chilled liquid temperature reset range. Then automatic remote temperature reset is accomplished by supplying (by others) the input signal to the Card File field wiring terminal board shown in Fig. U. Three input signal choices are available using option card #2. The user first determines which one is desired: (1) 4 to 20 mA D.C., (2) 0 to 10 volts D.C., or (3) single contact closure. Two slip-on programming mode jumpers are furnished with card #2. Simply place the program jumper(s) on the 2-pin connectors (see Detail C) according to the positions indicated by Table 3. Note only one jumper is used if the contact closure mode was chosen.

The optional Card File (Fig. U) must have been previously field installed (by others) in the MicroComputer Control Center, because it serves as the mounting medium for card #2. Field install (by others) card #2 by just sliding it into the slot-

ted card guides of the Card File; connect the wiring harness (by others) from card #2 terminal block (TB1) to control center terminal board (TB2) as shown. Input signal wiring is field connected (by others) to the Card File field wiring terminals, as shown in Detail 1, 2 or 3 (see Page 17). Select the detail that agrees with how program jumper(s) were positioned on card #2. For more details on Card File field wiring terminal board, refer to Fig. U—see View A-A.

The timer circuit on card #2 will permit the unit to begin responding to an input signal change within 150 seconds after the signal is received. Following a remote setpoint signal, the leaving chilled water temperature setpoint changes to the value corresponding to the signal (see Details 1, 2 or 3). When the remote setpoint signal is removed, the setpoint reverts to the programmed leaving chilled water temperature following a 30 minute built-in time delay.

Order, at additional cost, York Remote Leaving Chilled Water Temperature Setpoint Option Card, Part No. 031-00814-000; shipped loose for field installation (by others). The optional Card File (Fig. U) is **REQUIRED** if card #2 is ordered. When remote current limit setpoint option card #1 is also ordered (Fig. V), cards #1 AND #2 are required, but only ONE Card File is ordered. Refer to card #2 Installation Instructions, Form 160.45-N2.3.

Option card #2 in Fig. W can be applied in conjunction with Fig. V (option card #1). Thus, providing the capability of remotely controlling both leaving chilled water temperature setting AND motor current limit setting simultaneously, if so desired.

**See Page 16 for Details 1, 2 & 3.**

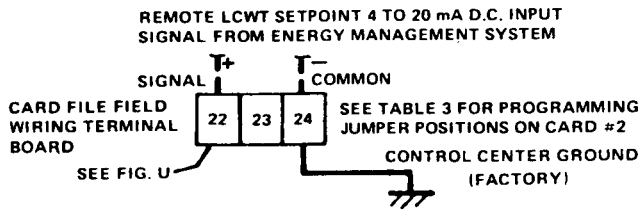

**DETAIL 1—4 to 20 mA D.C. INPUT CURRENT SIGNAL CONNECTIONS**

**DETAIL 1**—Remote Leaving Chilled Water Temperature Setpoint is accomplished by supplying a 4 to 20 mA D.C. input current signal (by others) across terminals **22** and **24** on the Card File field wiring terminal board (see Fig. U). Option card #2 program jumper positions must be per Table 3. A 4 mA signal corresponds to zero deg. F offset and therefore at the programmed leaving chilled liquid temperature setpoint. A 20 mA signal corresponds to maximum offset (10°F or 20°F as programmed) above the programmed leaving chilled liquid temperature setpoint. The amount of offset varies linearly with the 4 to 20 mA signal. For example, 12 mA applied (across terminals **22** and **24** of the Card File) to the unit programmed for 45°F leaving chilled water temperature setpoint and 10°F “Remote Reset Temp. Range,” the new setpoint would be:

Temperature Offset—

$$\text{Deg. F Offset} = \frac{(\text{mA signal} - 4) (\text{remote reset temp. range})}{16}$$

$$\text{Deg. F Offset} = \frac{(12 - 4) (10)}{16} = 5^\circ\text{F}$$

Setpoint = Keypad entered setpoint + °F offset

Thus, the new leaving chilled water temperature control point is 45°F + 5°F = 50°F

The maximum rate at which the MicroComputer Control Center will accept remote leaving chilled water temperature setpoint mA signal is once each 150 seconds.

For remote leaving chilled water temperature setpoint via a 0 to 10 volt D.C. signal—see Detail 2, or a single contact closure—see Detail 3. Refer to Fig. P for pulse-width modulated signal.

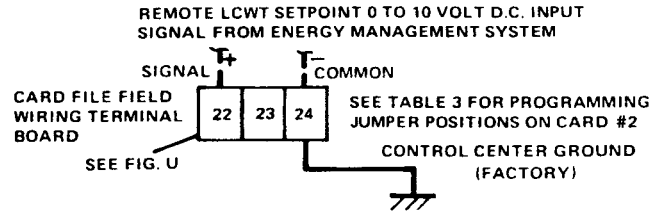

**DETAIL 2—0 TO 10 VOLT D.C. INPUT VOLTAGE SIGNAL CONNECTIONS**

**DETAIL 2**—Remote Leaving Chilled Water Temperature Setpoint is accomplished by supplying a 0 to 10 volt D.C. input voltage signal (by others) across terminals **22** and **24** on the Card File field wiring terminal board (see Fig. U).

Option card #2 program jumper positions must be per Table 3. A 0 volt D.C. signal corresponds to zero deg. F offset and therefore at the programmed leaving chilled liquid temperature setpoint. A 10 volt D.C. signal corresponds to maximum offset (10 °F or 20 °F as programmed) above the programmed leaving chilled liquid temperature setpoint. The amount of offset varies linearly with the 0 to 10 volt D.C. signal. For example, 5 volts D.C. applied (across terminals **22** and **24** of the Card File) to the unit programmed for 45°F leaving chilled water temperature setpoint and 10°F “Remote Reset Temp. Range.” The new setpoint would be:

Temperature Offset—

$$\text{Deg. F Offset} =$$

$$\frac{(\text{D.C. voltage signal}) (\text{remote reset temp. range})}{10}$$

$$\text{Deg. F Offset} = \frac{(5) (10)}{10} = 5^\circ\text{F}$$

Setpoint = Keypad entered setpoint + °F offset

Thus, the new leaving chilled water temperature control point is 45°F + 5°F = 50°F.

The maximum rate at which the MicroComputer Control Center will accept remote leaving chilled water temperature setpoint D.C. voltage signal is once each 150 seconds.

For remote leaving chilled water temperature setpoint via a 4 to 20 mA signal—see Detail 1, or a single contact closure see Detail 3. Refer to Fig. P for pulse-width modulated signal.

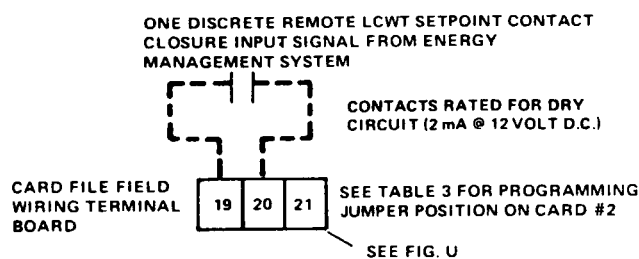

**DETAIL 3—CONTACT CLOSURE INPUT SIGNAL CONNECTIONS**

**DETAIL 3**—Remote Leaving Chilled Water Temperature Setpoint is accomplished by supplying a single dry circuit contact closure, 2 milliamperes @ 12 volts (by others) across terminals **19** and **20** on the Card File field wiring terminal board (see Fig. U). Option card #2 program jumper (one) position must be per Table 3. The contact closure provides one discrete remote leaving chilled water temperature setpoint corresponding to the leaving chilled water temperature setting (screw adjustable) that has been previously field selected (by others) on card #2 potentiometer (R11)—see top left corner of card #2—if unit has a VSD refer to Note 15.

**FIG. W (Continued)—REMOTE LEAVING CHILLED WATER TEMPERATURE SETPOINT OPTION CARD #2 (NOTE 15)**

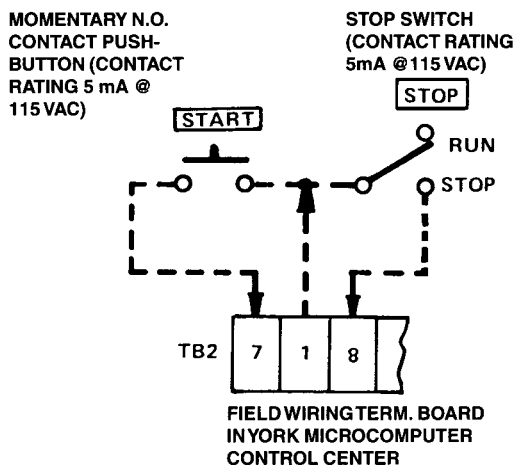

**FIG. X—REMOTE START-STOP PUSHBUTTON STATION**

**FIG. X—REMOTE START-STOP STATION**—When the remote Start-Stop contacts (see Fig. E) are not connected to an Energy Management System, terminals **7**, **1** and **8** on terminal board TB2 may be connected to a Remote Start-Stop Station. Whenever the MicroComputer Control Center is in the “remote” operating mode, the unit can be started and stopped from a remote location by employing a momentary normally open contact pushbutton for Remote Start and a maintained switch for Remote Stop.

*Note—Remote Start-Stop Station only functions in “remote” operating mode.*

When the Remote Mode Ready to Start contacts close in Fig. A (meaning the panel is in the “remote” operating mode and the “compressor” switch is in the “run” position and the Remote Stop Switch is in the “run” position (**1** to **8**) open), the unit will start via a momentary closure of the Remote Start Pushbutton. A subsequent closure of the maintained Remote Stop Switch to the “stop” position causes the unit to shutdown. The MicroComputer Control Center will display the following message: “SYSTEM SHUTDOWN—PRESS STATUS.” Upon pressing “status” key, “REMOTE STOP” message will be displayed when the Remote Stop switch has commanded the unit to shutdown.

*Note—Even when the unit is applied with Remote Start-Stop (when the panel is in the “remote” operating mode), an EMERGENCY STOP by an operator or others can STOP the compressor from the MicroComputer Control Center and prevent the unit from restarting. However, the operator cannot locally start the compressor using “compressor” start switch, when the panel is in the “remote” operating mode. To enter “remote” operating mode, a four digit access code must be entered for security.*

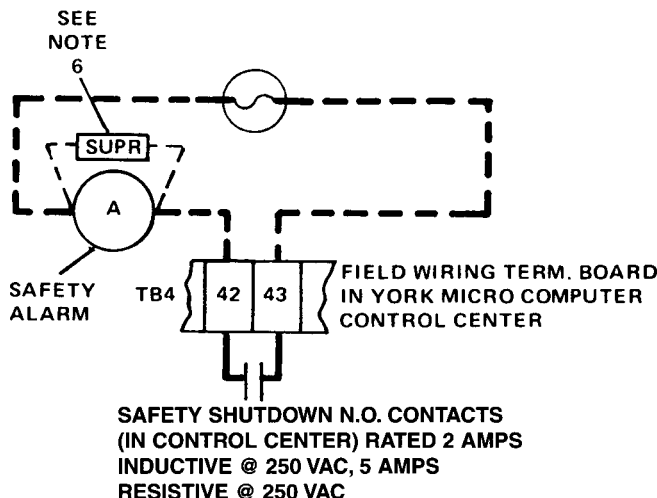

**FIG. Y—EXTERNAL SIGNAL FOR REFRIGERATION UNIT FAILURE (NOTE 6)**

**FIG. Y—EXTERNAL SIGNAL FOR REFRIGERATION UNIT FAILURE**—When the Safety Shutdown Contacts (see Fig. C) are not connected to an Energy Management System they may be employed to energize a local or remote safety alarm (by others). When the normally open Safety Shutdown Contacts close, the alarm will indicate shutdown of the unit. The cause of shutdown will be one or more of the following safety controls: low oil pressure, high oil pressure, high condenser pressure, low evaporator pressure, high oil temperature, high discharge temperature (see page 5 for list of safety shutdowns for VSD to be included in addition to these), power failure when the “Auto Restart After Power Failure” programming jumper is NOT installed on the Micro Board (Fig. R), which implies that the Chiller requires “manual restart after failure.” On solid state starter units only, when jumper JP5 (marked “CUR UNBAL”) is installed in the micro board, three phase current unbalance protection is provided. A safety shutdown occurs (following a 45 second by-pass at start up) whenever the % FLA readout exceeds 80% for 45 seconds continuously and the % unbalance is  $\geq 30\%$ . When all safety controls are satisfied, and the MicroComputer Control Center “compressor” switch has been manually “reset” (de-energizing alarm) and returned to the “run” position, the Chiller unit may be restarted, if panel is in “remote” mode, via the Remote Start contacts (Fig. E) or if panel is in “local” mode by pressing keypad compressor “Start” switch.

*Note—If the unit was shutdown because of Cycling Shutdown Contacts (see Fig. B) the alarm will not be energized, but the unit will have been shutdown. A closure of the safety alarm contacts means that an operator must manually reset and restart the unit.*

When the Safety Shutdown contacts close, the MicroComputer Control Center will display the following message: “SYSTEM SHUTDOWN—PRESS STATUS,” or “VSD SHUTDOWN—PRESS STATUS” if VSD. Upon pressing “status” key, the status message consists of the day and time of shutdown plus cause of shutdown.

**ELEMENTARY DIAGRAM**

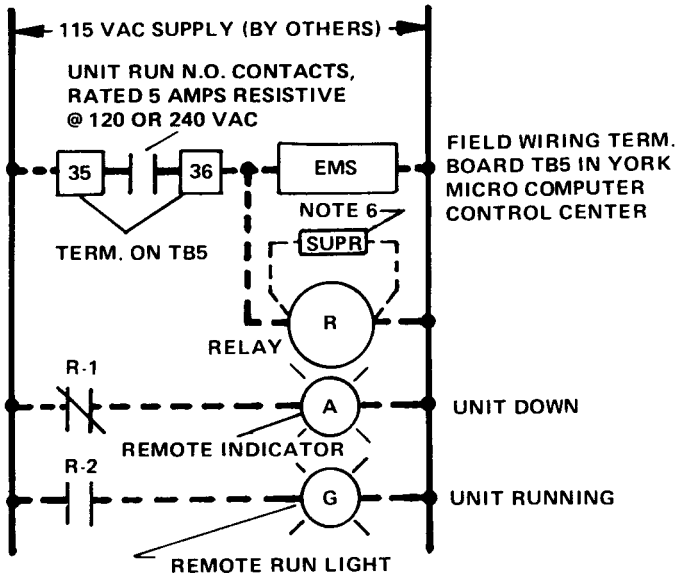

**FIG. AA—RUN CONTACTS/REMOTE RUN LIGHT AND SHUTDOWN INDICATOR PLUS EMS**—When run contacts are required for a Remote Run Light and/or Shutdown Indicator AND Energy Management System (EMS), connect (by others) as shown in the diagram. The EMS, control relay, shutdown and run lights are furnished by others. When the N.O. contacts close, between terminals [35] and [36] on field wiring terminal board TB5 in the MicroComputer Control Center, this indicates that the unit is operating; the remote Run Light will be energized. The unit run contacts open when the unit is shutdown (safety or cycling) and the remote indicator will then be energized. For run contacts to EMS only refer to Fig. D. When terminals [35] and [36] are not used for an EMS, they may be connected to a remote Run Light. The control relay scheme shown in Fig. AA can also be applied for a remote Run Light AND a Remote Shutdown Indicator, when an EMS is not used.

**FIG. AA—RUN CONTACTS/REMOTE RUN LIGHT AND SHUTDOWN INDICATOR PLUS EMS**

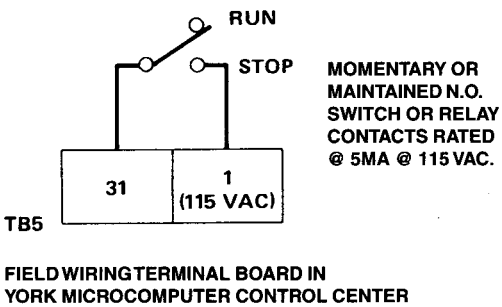

The closure of a Momentary or Maintained N.O. Switch or Relay Contacts will cause the unit to shutdown and display: "SYSTEM SHUTDOWN—PRESS STATUS." Upon pressing STATUS key, "DAY XX:XX AM (DAY MONTH XXXX [military time] if equipped with VSD)—AUX. SAFETY SHUTDOWN" is displayed. The unit will not restart until the contacts open and the keypad COMPRESSOR switch is moved to the "STOP-RESET" position and then to the "START" position.

**FIG. BB—AUXILIARY SAFETY SHUTDOWN INPUT**

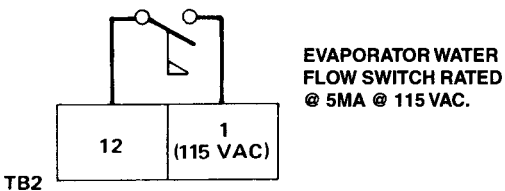

When Evaporator Water is flowing, the flow switch contact will close. If the flow switch opens for 2 seconds, the unit shuts down and displays "SYSTEM SHUTDOWN—PRESS STATUS." Upon pressing STATUS key, "DAY XX:XX AM (DAY MONTH XXXX [military time] if equipped with VSD)—FLOW SWITCH—AUTO START" is displayed. The unit will automatically restart when the switch again closes. The flow switch status is checked 25 seconds into "START SEQUENCE INITIATED" and continuously thereafter.

**FIG. CC—EVAPORATOR WATER PUMP INTERLOCK OR FLOW SWITCH**

TO ENERGY MANAGEMENT  
SYSTEM FROM CHILLER

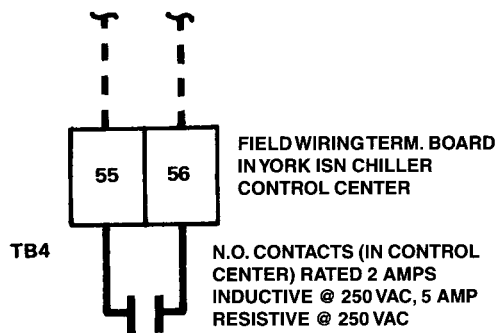

**FIG. DD—EXCESS PURGE WARNING CONTACTS**—(Note: This feature applies to ISN CHILLER CENTERS equipped with relay board part number 031-00932-002.) When closed, these contacts signify that the unit exceeds the programmed threshold for the maximum number of purge exhausts allowed per hour; in addition, the control center displays the message “DAY XX:XX AM (DAY MONTH XXXX [military time] if equipped with VSD) WARNING—EXCESS PURGE” alternating with the normal foreground message. To open the excess purge contacts and clear the warning message, press the WARNING RESET key in SERVICE mode.

**FIG. DD—EXCESS PURGE WARNING CONTACTS**

## NOTES

1. This drawing shows recommended field control wiring modifications (by others) to the standard MicroComputer Control Center wiring diagram. Refer to MicroComputer Control Center Wiring Diagram: Product Drawing Form 160.48-PA20, units furnished with a York solid state compressor-motor starter; Product Drawing Form 160.48-PA19, units having a remote electro-mechanical compressor-motor starter; Product Drawing Form 160.48-PA21, units having a Factory Packaged VSD.
2. If more than one of these modifications is to be utilized with a particular unit, additional consideration must be given to the application to insure proper functioning of the control system. Consult your YORK representative.
3. The additional controls and wiring for these modifications are to be furnished and installed in the field (by others).
4. The controls specified are recommended for use, but other controls of equal specifications are acceptable.
5. All wiring shall be in accordance with the National Electrical Code, and applicable State and Local Codes.
6. Each 115 VAC field connected inductive load; i.e., relay coil, motor starter coil, etc., shall have a transient suppressor wired (by others) in parallel with its coil, physically located at the coil. Spare transient suppressors are furnished in a bag in the MicroComputer Control Center.
7. The MicroComputer Control Center is factory furnished for Manual Restart After Power Failure as a standard function. The control center can be field changed from Manual Restart to Auto Restart after a power failure by plugging in a programming jumper—See Fig R.
8. Two (2) unit control schemes are suitable for 8–12°F water range. Constant chilled water flow is assumed at all loads. For other requirements contact your YORK representative. Also applicable for two units—each with a VSD or two units when only one unit has a VSD.
10. Lead selector and cycling control to provide similar lead selection and cycling of lag units for three (3) units is available: Kit No. 366-44684D (see Product Drawing Form 160.00-PA1.1) in NEMA I enclosure; for 4 units, Kit No. 366-52529D (see Product Drawing Form 160.00-PA1.2) in NEMA I enclosure. Consult your YORK representative.
11. Sequence control kits (see Fig. J and Note 10) assume a constant chilled water flow and a constant leaving chilled water temperature to sense the cooling load. Sequence control kits are not designed for variable chilled water flow or with reset of the leaving chilled water temperature—see Figs. P & W and Note 2.
12. Maximum allowable current draw between circuits **[24]** and **[2]** for field installed devices is 2 amp holding and 10 amps inrush—see MicroComputer Control Center Wiring Diagram Form No. in Note 1.
13. For required field wiring connections of the chilled water pump contacts (terminals **[44]** and **[45]** on MicroComputer Control Center field wiring terminal board TB4) and chilled water flow switch (terminals **[1]** and **[12]** on MicroComputer Control Center field wiring terminal board TB2), see Wiring Diagram—Field Connections—Form 160.48-PA17 (units with York Solid State Starter), or Form 160.48-PA18 (units having a Remote Electro-Mechanical Starter), or Form 160.48-PA15 (units with a factory packaged VSD). Form 160.48-PA18 also shows required field wiring connections between the compressor motor remote starter and Chiller.  
  
The chilled water flow switch is a safety control. It must be connected to prevent operation of the unit whenever chilled water flow is stopped. The use of the chilled water flow switch for purposes other than protection of the Chiller unit may be accomplished in several ways. Two flow switches, a flow switch and a relay or separate contacts on the same flow switch.
15. Do not apply voltage on field wiring terminal boards TB2 and TB5 in York MicroComputer Control Center, as 115 VAC source is fed from terminals **[1]** and **[2]**.

