

# MODEL YSAA AIR-COOLED SCREW CHILLERS STYLE A

65 – 135 TON  
255 – 475 kW  
60 Hz  
R-134A

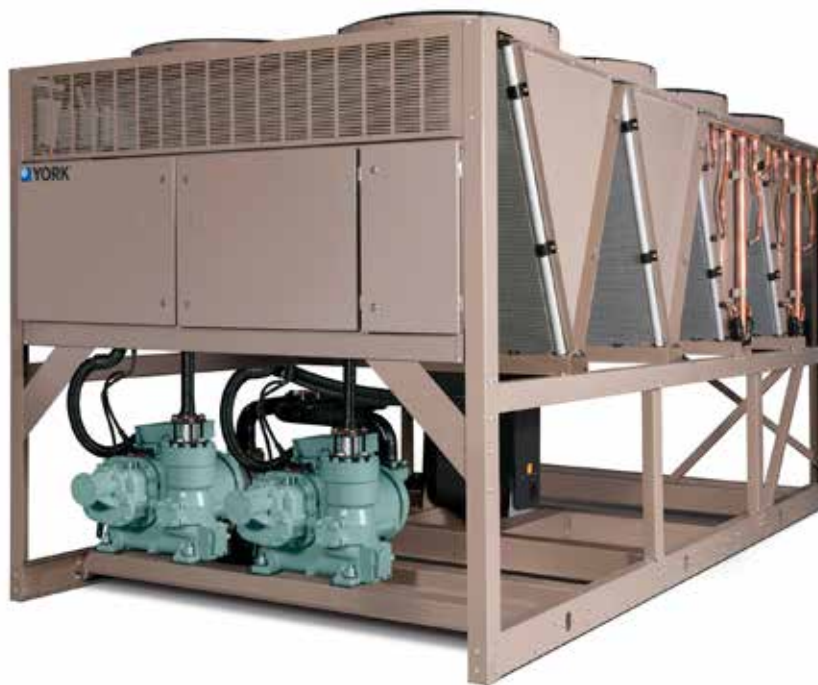

# Nomenclature

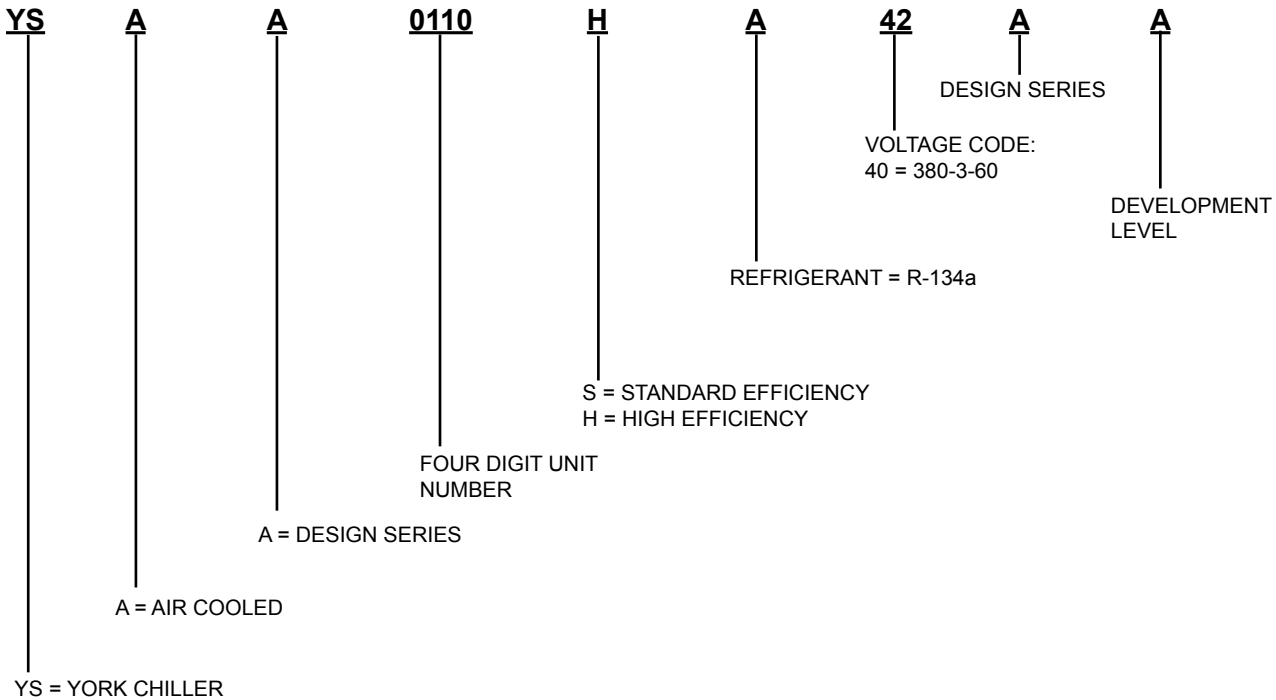

# Approvals

- ASME Boiler and Pressure Vessel Code – Section VIII Division 1.
- AHRI Standard 550/590 and 551/591.
- UL 1995 – Heating and Cooling Equipment
- ASHRAE 15 – Safety Code for Mechanical Refrigeration
- ASHRAE Guideline 3 – Reducing Emission of Halogenated Refrigerants in Refrigeration and Air-Conditioning Equipment and Systems
- N.E.C. – National Electrical Code
- OSHA – Occupational Safety and Health Act



Products are produced at a facility whose quality-management systems are ISO9001 certified.

# Table Of Contents

INTRODUCTION .....	5
EQUIPMENT OVERVIEW .....	7
UNIT COMPONENTS .....	14
ACCESSORIES AND OPTIONS .....	15
DESIGN PARAMETERS .....	17
WATER PRESSURE DROP .....	18
PHYSICAL DATA AND NOMINAL RATINGS .....	19
PART LOAD RATINGS .....	20
UNIT DIMENSIONS .....	21
ISOLATOR LOCATIONS .....	24
ISOLATOR DETAILS .....	27
ELECTRICAL NOTES .....	29
WIRING LUGS .....	31
ELECTRICAL DATA WITHOUT PUMPS .....	32
WIRING DIAGRAM .....	34
USER CONTROL WIRING .....	38
APPLICATION DATA .....	39
GUIDE SPECIFICATIONS .....	41
SI METRIC CONVERSION .....	49

Performance data provided in this document was created in accordance with Johnson Controls software: **YORKworks version 13.02 and DXCHILL version 6.04**

THIS PAGE INTENTIONALLY LEFT BLANK.

# Introduction

Johnson Controls, the building efficiency leader, is proud to present the YORK Model YSAA Air-Cooled Screw Chiller.

## FEATURES AND BENEFITS

### Installation

The YSAA chiller arrives as a factory-assembled package ready to be installed outdoors, either on the roof or at ground level. The air-cooled condensers eliminate the capital, installation and maintenance costs of a cooling-tower circuit.

The YSAA weighs less and has a smaller footprint than other chillers in its class. In fact, it is 20-35% lighter weight than the market average chiller. When the chiller is roof-mounted in new construction, the cost of the support structure can be reduced. In building retrofits, the YSAA can provide the largest capacity in a given space and existing structure.

Power hook-up could not be any easier with the standard single-point connection. A terminal block, or circuit breaker is provided to meet the unique needs of every project and minimize installation time and labor. The factory-installed control transformer steps down the power voltage to the control voltage.

Chilled-water piping is also simple. The water connections are factory-piped to the outside of the unit, for ease of access. Factory-cut grooves, or optional flanges, make piping connections simple.

Press the start button with confidence – your YSAA has been run-tested at the factory to ensure that you will have a successful start-up.

### Reliability

The YSAA chiller is proven and reliable, designed to reduce service calls. The screw compressors have logged hundreds of thousands of operating hours in numerous different applications. The corrosive-resistant condenser heat exchangers have been specifically designed for stationary HVAC applications and have undergone extensive laboratory and field testing to extend chiller life and improve performance. They are also more rigid than standard condenser coils, making them less susceptible to damage during rigging, lifting, and installation of the chiller.

Components are designed to keep the chiller up-and-running. A factory-installed water strainer prevents debris from affecting unit flow and/or heat transfer. The rugged thermal-dispersion flow switch is factory-installed at the optimum location in the piping for superior flow sensing, reducing the potential for nuisance trips. Intelligent controls protect the chiller while keeping it online, for maximum uptime. Exterior panels of the chiller are powder-coated with highly durable corrosion-resistant paint.

## Introduction (Cont'd)

### Efficiency

YSAA high-efficiency chillers, with their innovative control algorithms, offer industry-leading energy efficiency. Real-world energy efficiency is measured by IPLV (off-design) performance, and YSAA chillers provide some of the best IPLVs in their class.

### Sustainability

The YSAA makes you a leader in sustainability through innovation, not added cost. With the combination of R-134A refrigerant, which has no ozone-depletion potential, and state-of-the-art heat exchanger technology that allows refrigerant charge to be reduced by as much as 30%, the YSAA chiller provides the most ecologically friendly equipment. Paired with its low-sound properties for noise pollution prevention, this chiller is a true earth-friendly offering.

### Communications

The YSAA chiller comes standard with native communication capability for BACnet (MS/TP), Modbus, and N2, with optional capabilities available for LON. The standard unit capabilities include built-in-scheduling, remote start-stop, remote water temperature reset and up to two steps of demand (load) limiting depending on model. The standard control panel can be directly connected to a Johnson Controls Building Automated System via the standard factory-installed RS232 communication port.

### Serviceability

Minimal maintenance is required to keep the unit operating at maximum performance. If service should ever be required, the YSAA chiller has been designed to simplify the work, keeping costs down. The layout of the chiller locates all the major components that can be serviced near the outside edge. The condenser heat exchangers are light enough that no crane is required for replacement. And when it's time to clean them, city tap water, with water pressure typical of a spray from a common garden hose, is all that's needed.

### AHRI CERTIFICATION PROGRAM

YORK YSAA chillers have been tested and certified by Air-Conditioning, Heating and Refrigeration Institute (AHRI) in accordance with the latest edition of AHRI Standard 550/590 (I-P). Under this Certification Program, chillers are regularly tested in strict compliance with this Standard. This provides an independent, third-party verification of chiller performance. Refer to the AHRI site at [www.ahrinet.org/](http://www.ahrinet.org/) for complete Program Scope, Inclusions, and Exclusions as some options listed herein fall outside the scope of the AHRI certification program. For verification of certification, go to the AHRI Directory at [www.ahridirectory.org](http://www.ahridirectory.org).



Rated in accordance with the latest issuance of AHRI Standard 550/590 and 551/591.

## Equipment Overview

The 65 - 135 Ton (225 - 475 kW) YSAA models are shipped complete from the factory ready for installation and use. The unit is pressure-tested, evacuated, and fully charged with a zero Ozone Depletion Potential Refrigerant R-134A and includes an initial oil charge. After assembly, a complete operational test is performed with water flowing through the evaporator to assure that the refrigeration circuit operates correctly.

The unit structure is heavy-gauge, galvanized steel. This galvanized steel is coated with baked-on powder paint, which, when subjected to ASTM B117 1000 hour, salt spray testing, yields a minimum ASTM 1654 rating of "6". Units are designed in accordance with NFPA 70 (National Electric Code), ASHRAE/ANSI 15 Safety code for mechanical refrigeration, ASME and rated in accordance with AHRI Standard 550/590 and 551/591.

### COMPRESSORS

The chiller has suction-gas cooled, hermetic screw compressors. All rotating parts are statically and dynamically balanced. A large internal volume and oil reservoir provides greater liquid tolerance.

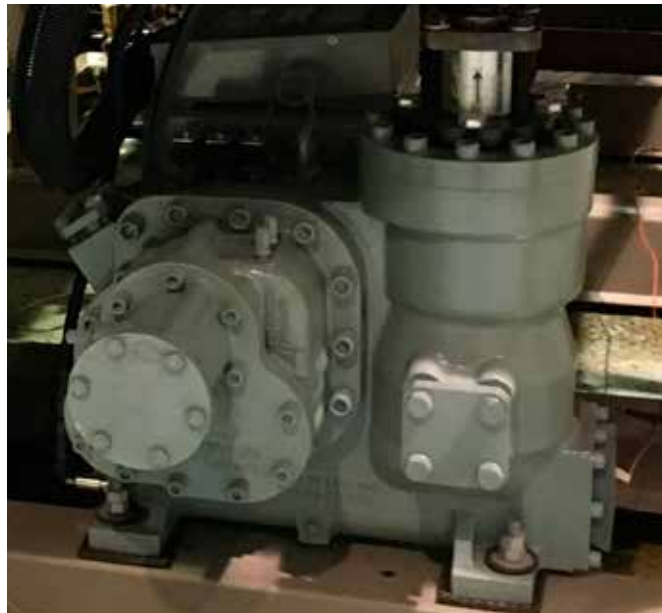

LD20512

## Equipment Overview (Cont'd)

### BRAZED PLATE EVAPORATOR

The compact, high efficiency Brazed Plate Heat Exchanger (BPHE) is constructed with 316L stainless steel corrugated channel plates with a filler material between each plate. It offers excellent heat transfer performance with a compact size and low weight, reducing structural steel requirements on the job site.



LD20513

The heat exchanger is manufactured in a precisely controlled vacuum-brazing process that allows the filler material to form a brazed joint at every contact point between the plates, creating complex channels. The arrangement is similar to older plate and frame technology, but without gaskets and frame parts.

Water inlet and outlet connections are 3" in diameter and are grooved for compatibility with field supplied ANSI/AWWA C-606 couplings.

A 20 mesh wye-strainer is provided as standard to provide protection at the evaporator inlet, particularly at system start-up when construction debris may be present in the piping system.

The evaporator is equipped with a thermostat-controlled heater. The heater provides freeze protection for the evaporator down to -20°F (-29°C) ambient. The evaporator is covered with 3/4" flexible, closed-cell, foam insulation (K=0.25).

A factory-wired flow switch is standard, installed in a pipe section at the outlet of the evaporator.

## Equipment Overview (Cont'd)

### CONDENSER

**Coils** - Condenser coils are made of a single material to avoid galvanic corrosion due to dissimilar metals. Coils and headers are brazed as one piece. Integral sub cooling is included. The design working pressure of the coil is 350 PSIG (24 BarG). Condenser coil is easily washable with clear water up to 100 PSI (7 bar).



LD18427

**Fans** - The condenser fans are composed of corrosion resistant aluminum hub and glass-fiber-reinforced polypropylene composite blades molded into a low-noise airfoil section. They are designed for maximum efficiency and are statically and dynamically balanced for vibration-free operation. They are directly driven by independent motors, and positioned for vertical air discharge. The fan guards are constructed of heavy-gauge, rust-resistant, coated steel. All blades are statically and dynamically balanced for vibration-free operation.



LD18428

**Motors** - The fans are driven by Totally Enclosed Air-Over, squirrel-cage type, current protected motors. They feature ball bearings that are double-sealed and permanently lubricated.

## Equipment Overview (Cont'd)

### UNIT CONTROL SYSTEM

The YSAA chiller is designed with an intelligent control system that operates the chiller automatically with maximum reliability, safety and ease of use. The controls are factory tested and with as little user input as a chilled liquid setpoint the chiller will operate to meet the load demand.

The control system includes native BACnet MS/TP, Modbus and N2 communications, with LON protocol served through an optional eLink communications card.

The operating program is stored in non-volatile memory (EPROM), so power failures and battery discharge will not require reprogramming the chiller. Programmed setpoints are retained in lithium battery-backed RTC memory for five years minimum.

Unit alarm contacts are standard. Contacts for remote chilled liquid temperature reset and two steps of demand load limiting are also standard, for projects without BAS or for redundancy.

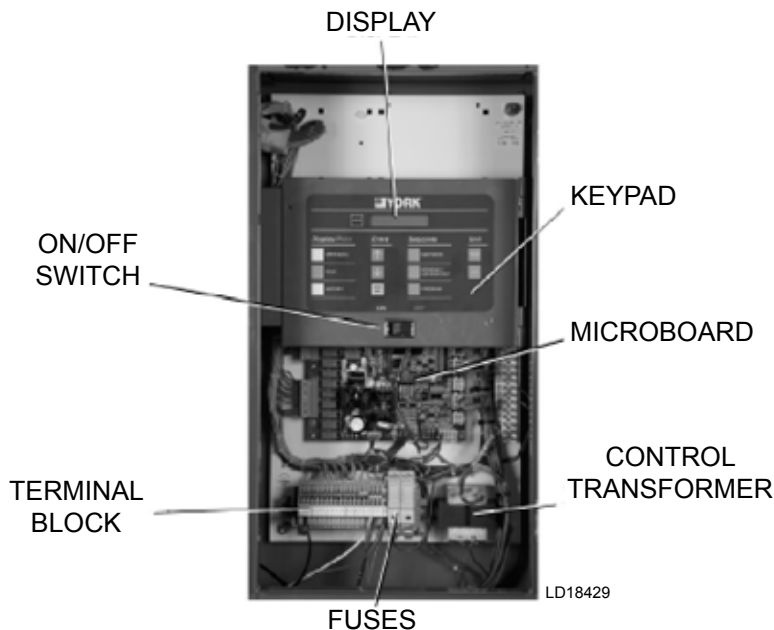

Maximum reliability is achieved through intelligent control. Run hours and starts are averaged across all compressors automatically. When compressors are cycled off, an anti-recycle timer ensures the motors have time to cool before starting again, for the maximum service life. At unit shutdown, the unit pumps down automatically to prevent liquid refrigerant from entering the compressors at restart, which can cause premature bearing wear and other compressor damage.

Liquid temperature sensors provide feedback to the controller, and logic predicts when additional capacity will be required based on how quickly the unit has loaded or unloaded in the past. This prevents unnecessary compressor cycling and helps maintain setpoint accurately.

## Equipment Overview (Cont'd)

If there is a problem that prevents the unit operating properly, the controls are designed to allow the unit to operate safely while making as much capacity as possible. For example, if airflow to the condenser coil is diminished due to a dirty coil, the chiller will unload slightly to provide maximum capacity possible while remaining within the unit operating envelope.

If a fault prevents the unit from starting or causes it to shutdown, the chiller will attempt to restart three times. If it cannot start, a manual reset is required to alert the operator about the fault condition. The fault history is stored in the unit controller RTC memory for the last six fault shutdown conditions. An RS-232 port provides capability to print hard copy reports (printer available separately).

All controls are contained in a NEMA 3R cabinet with a hinged outer door and includes a liquid crystal display (LCD) with light emitting diode (LED) backlighting for outdoor viewing. There are two display lines, each with 20 text characters per line, and a color coded 12-button non-tactile keypad with sections for display, entry and printing.

**DISPLAY/PRINT** provides quick access to frequently needed information:

- Chilled liquid temperatures
- Ambient temperature
- System pressures (each circuit)
- Operating hours and starts (each compressor)
- Operating data for the systems

**ENTRY** section allows entering setpoints or modifying system values.

**SETPOINTS** updating can be performed to:

- Chilled liquid temperature setpoint and range
- Remote reset temperature range
- Set daily schedule/holiday for start/stop
- Manual override for servicing
- Low and high ambient cut-outs
- Number of compressors
- Low liquid temperature cut-out
- Low suction pressure cut-out
- High discharge pressure cut-out
- Anti-recycle timer (compressor start cycle time)
- Anti-coincident timer (delay compressor starts)

## ***Equipment Overview (Cont'd)***

**UNIT** section to:

- Set time
- Set unit options

In addition, the microprocessor control center is capable of displaying the following data points:

- Return and leaving liquid temperature
- Low leaving liquid temperature cut-out setting
- Low ambient temperature cut-out setting
- Outdoor air temperature
- English or Metric data
- Suction pressure cut-out setting
- Each system suction pressure
- Discharge pressure (optional)
- Anti-recycle timer status for each system
- Anti-coincident system start timer condition
- Compressor run status
- No cooling load condition
- Day, date and time
- Daily start/stop times
- Holiday status
- Automatic or manual system lead/lag control
- Lead system definition
- Compressor starts & operating hours (each compressor)
- Status of hot gas valves, evaporator heater and fan operation
- Run permissive status
- Number of compressors running
- Liquid solenoid valve status
- Load & unload timer status
- Water pump status

## Equipment Overview (Cont'd)

### COMMUNICATIONS

- Native communication capability for BACnet (MS/TP), Modbus and N2
- Optional communication available for LON via eLink option

### BUILDING AUTOMATION SYSTEM INTERFACE

In addition to native BACnet, Modbus and N2, the YSAA chiller accepts a 4-20 milliamp or 0-10VDC input to reset of the leaving chilled liquid temperature. The standard unit capabilities include remote start-stop, remote water temperature reset via up to two steps of demand (load) limiting depending on model. The standard control panel can be directly connected to a Johnson Controls Building Automated System via the standard on-board RS232 communication port. (Factory- installed)

### POWER PANEL

- Each panel contains:
  - Compressor power terminals
  - Compressor motor starting contactors per I.E.C.
  - Control power terminals to accept incoming for 115-1-60 control power
  - Fan contactors & overload current protection

The power wiring is routed through liquid-tight conduit to the compressors and fans.

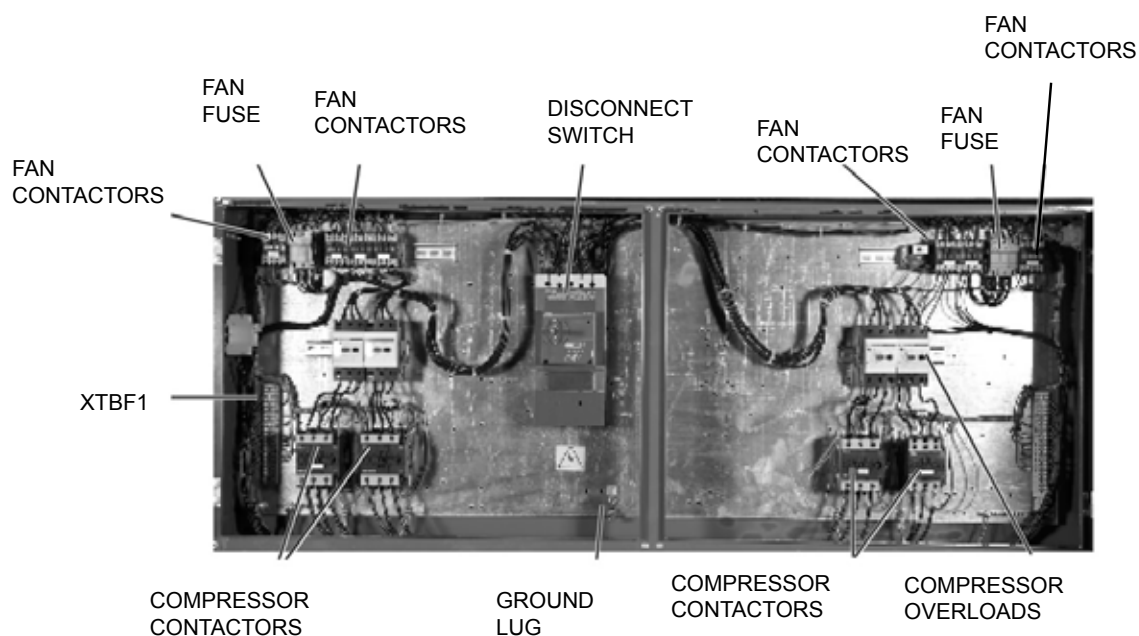

LD18430

# Unit Components

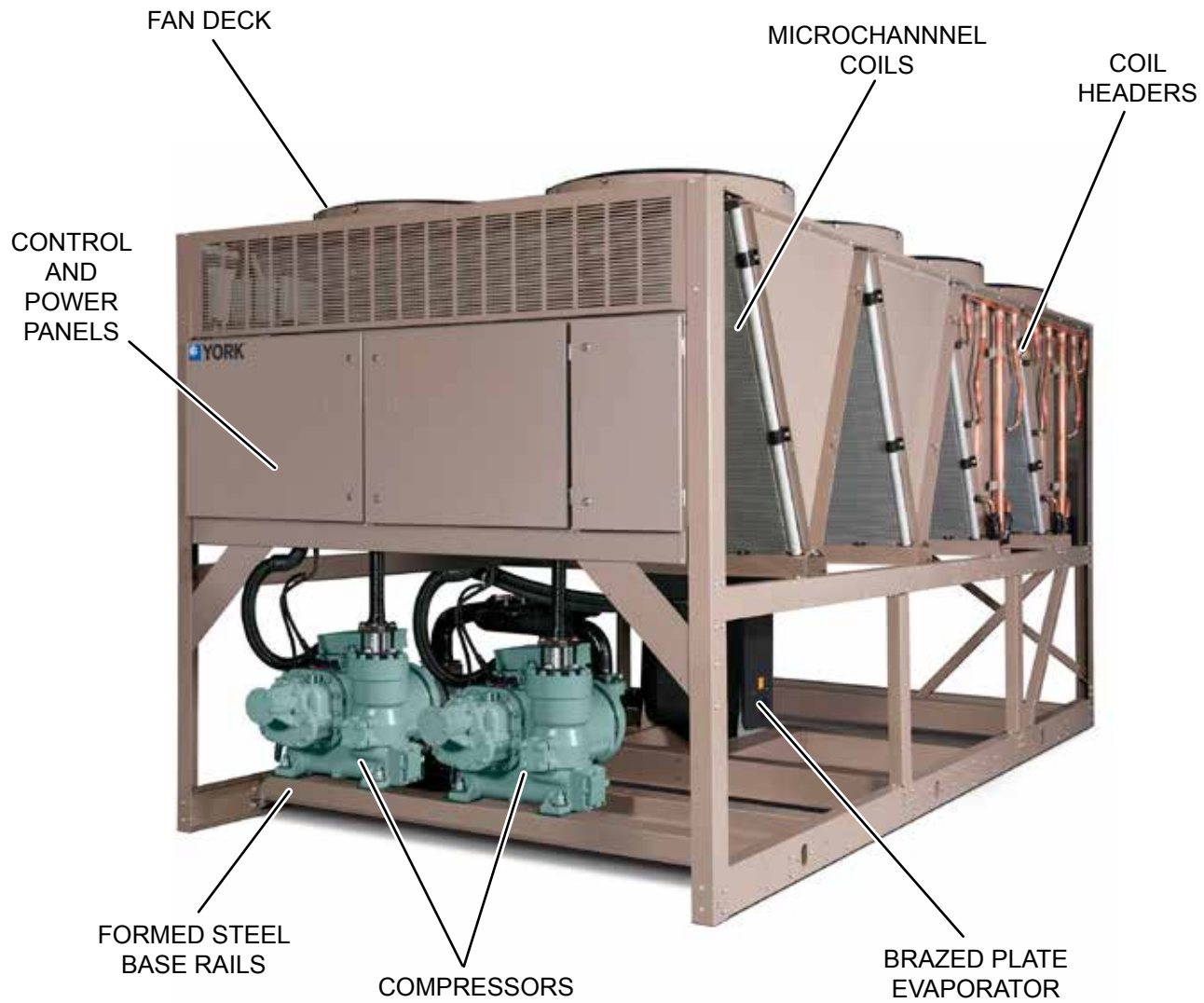

LD20515

FIGURE 1 - GENERAL UNIT COMPONENTS

## Accessories and Options

All options are factory installed unless otherwise noted.

### POWER OPTIONS:

**Unit Power Connections** – Single-point terminal block connection(s) are provided as standard. The following power connections are available as options. (See electrical data for specific voltage and options availability.)

**Single-Point Supply Terminal Block** – Includes enclosure, terminal-block and interconnecting wiring to the compressors. Separate external protection must be supplied, by others, in the incoming compressor-power wiring. (Do not include this option if either the Single-Point Non-Fused Disconnect Switch or Single-Point Circuit Breaker options have been included.)

**Single-Point Circuit Breaker** – A unit mounted circuit breaker with external, lockable handle (in compliance with NEC Article 440-14), can be supplied to isolate the power voltage for servicing. (This option includes the Single-Point Power connection.)

**Control Transformer** – Converts unit power voltage to 115-1-60 (0.5 or 1.0 kVA capacity). Factory mounting includes primary and secondary wiring between the transformer and the control panel.

### CONTROL OPTIONS:

**High Ambient Kit** – Allows units to operate when the ambient temperature is above 115°F (46°C). Includes sun shield panels and discharge pressure transducers.

**Low Ambient Kit** – Standard units will operate to 30°F (-1°C). This accessory includes all necessary components to permit chiller operation to 0°F (-18°C). (This option includes the discharge pressure transducer /readout capability option.) For proper head pressure control in applications below 30°F (-1°C) where wind gusts may exceed 5 mph, it is recommended that optional condenser louvered enclosure panels also be included.

### COMPRESSOR, PIPING, EVAPORATOR OPTIONS:

**Service Suction Isolation Valve** – Service suction discharge (ball-type) isolation valves are added to unit per system (discharge service ball-type isolation valve is standard on each circuit).

**Thermal Dispersion Flow Switch** – A thermal dispersion type flow switch provides accurate, low maintenance flow proving and is included standard. It is factory wired and installed in the extension pipe between evaporator outlet and edge of chiller. The extension pipe is secured to the chiller frame for shipping to avoid risk of damage to evaporator and is easily attached to the evaporator at startup using the supplied ANSI/AWWA C-606 connector. The flow switch can be deleted if alternate or existing flow switch is field supplied.

## ***Accessories and Options (Cont'd)***

### **CONDENSER AND CABINET OPTIONS:**

Condenser coil protection against corrosive environments is available by choosing any of the following options. For additional application recommendations, refer to FORM 150.12-ES1.

**Environment Guard Premium** – Microchannel condenser coils coated with an electro-deposited and baked flexible epoxy coating that is finished with a polyurethane UV resistant top-coat.

**Environment Guard Basic** – Microchannel condenser coils treated with immersion bath-applied chemical treatment.

**Microchannel condenser shall be provided with a 5-year warranty against corrosion damage.**

### **VIBRATION ISOLATION**

**Vibration Isolators** – Level adjusting, spring type 1 inch (25.4mm), deflection, or neoprene isolators for mounting under unit base rails. (**Field installed**)

## Design Parameters

NOMINAL EVAPORATOR WATER FLOW						
YSAA	TEMPERATURE °F (°C)		WATER FLOW GPM (L/S)		AIR ON CONDENSER °F (°C)	
	MIN <sup>1</sup>	MAX <sup>2</sup>	MIN	MAX	MIN <sup>3</sup>	MAX <sup>4</sup>
HIGH EFFICIENCY						
<b>0070HA</b>	40 (4.4)	60 (15.6)	40 (2.52)	350 (22.08)	0	125 (51.7)
<b>0090HA</b>	40 (4.4)	60 (15.6)	50 (3.15)	350 (22.08)	0	125 (51.7)
<b>0110HA</b>	40 (4.4)	60 (15.6)	60 (3.79)	350 (22.08)	0	125 (51.7)

**NOTES:**

1. For leaving liquid temperature below 40°F (4°C) (to 10°F [-12°C]) optional low temperature glycol kit required. Contact your nearest Johnson Controls Office for application requirements.
2. For leaving liquid temperature higher than 55°F (13°C), contact the nearest Johnson Controls Office for application guidelines.
3. The evaporator is protected against freezing to -20°F (-29°C) with an electric heater as standard.
4. For operation at temperatures above 115°F (46°C), the optional High Ambient Kit will need to be installed on the system.

# Water Pressure Drop

YSAA Evaporator Pressure Drop Curve

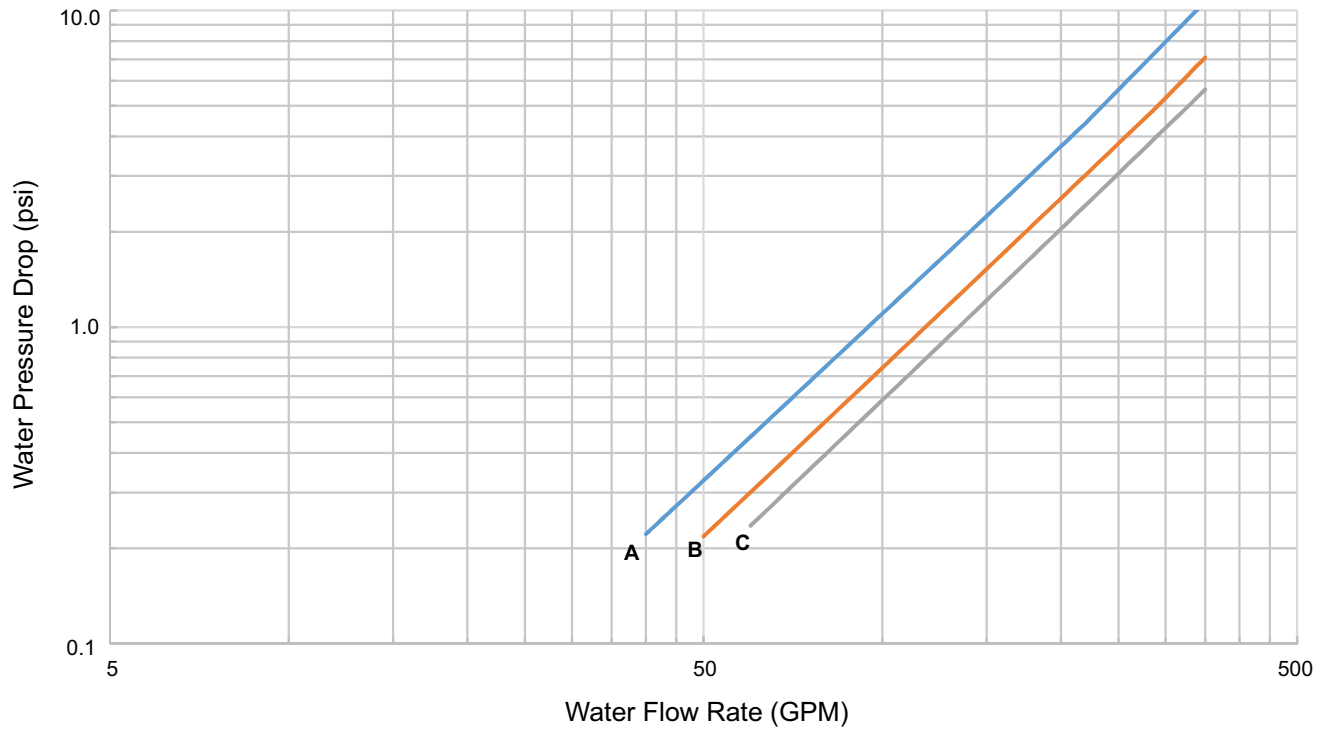

LD21025a

EVAPORATOR	YSAA MODELS
A	YSAA0070
B	YSAA0090
C	YSAA0110

## Physical Data and Nominal Ratings

REFRIGERANT R-134A	YSAA		
	HIGH EFFICIENCY UNITS		
	0070	0090	0110
<b>NOMINAL RATINGS</b>			
TONS	67.3	86.3	111.1
KW	69.9	86.9	122.7
EER	10.6	10.7	10.9
IPLV	14.4	14.1	15.1
<b>GENERAL UNIT DATA</b>			
Length, Inches	116.2	143.5	186.3
Width, Inches	88.3	88.3	88.3
Height, Inches	94.5	94.5	94.5
Number of Refrigerant Circuits	2		
<b>REFRIGERANT CHARGE, OPERATING</b>			
R-134A, Circuit 1 / Circuit 2, lbs	34/35.6	44/46	54.5/57
Oil Charge, Circuit 1 / Circuit 2, gallons	1.7	2	2.2
Shipping Weight, lbs	4415	5226	6441
Operating Weight, lbs	4594	5432	6668
<b>COMPRESSORS, SCREW TYPE</b>			
Compressors per circuit	1/1		
Compressors per unit	2		
<b>CONDENSER</b>			
Total Face Area ft <sup>2</sup>	106.9	160.4	213.8
Number of Rows	1		
Fins per Inch	20		
<b>CONDENSER FANS, LOW SOUND</b>			
Number of Fans, Circuit 1/Circuit 2	2/2	3/3	4/4
Fan hp	2		
Fan RPM	1160		
Total Chiller CFM	62,400	93,600	124,800
<b>EVAPORATOR</b>			
Water Volume, Gallons	9.7	12.9	15.5
Maximum Water Side Pressure, PSIG	150		
Maximum Refrigerant Side Pressure, PSIG	235		
Minimum Chiller Water Flow Rate, GPM	40	50	60
Maximum Chiller Water Flow Rate, GPM	350	350	350
Water Connections Size, Inches	3		

# Part Load Ratings

## HIGH EFFICIENCY

YSAA0070 60HZ				
% DISPL.	TONS	COMPR. KW	AMBIENT (°F)	UNIT EER
100	67.3	69.9	95.0	10.6
75	50.5	37.8	80.0	13.5
50	33.6	23.4	65.0	14.7
25	16.8	10.3	55.0	16.3
IPLV 14.4				
YSAA0090 60HZ				
% DISPL.	TONS	COMPR. KW	AMBIENT (°F)	UNIT EER
100	86.3	86.8	95.0	10.7
75	64.7	51.1	80.0	13.4
50	43.1	28.7	65.0	14.4
25	21.6	13.4	55.0	15.2
IPLV 14.0				
YSAA0110 60HZ				
% DISPL.	TONS	COMPR. KW	AMBIENT (°F)	UNIT EER
100.0	111.1	122.7	95.0	10.9
75.0	83.3	72.1	80	13.9
50.0	55.5	42.3	65	15.8
25.0	27.8	18.9	55.0	17.6
IPLV 15.1				

# Unit Dimensions

## YSAA0070HA

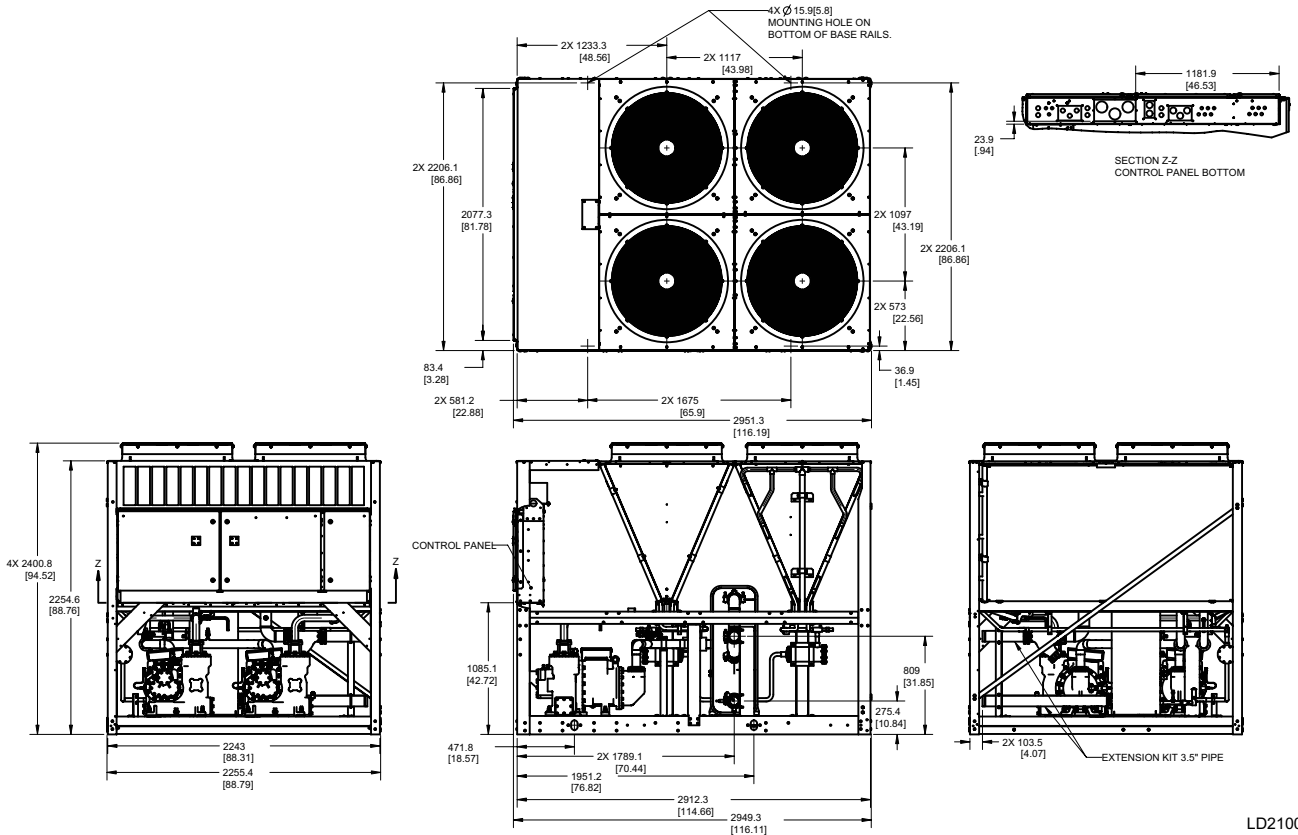

LD21004

**NOTE:**

Placement on a level surface of free of obstructions (including snow, for winter operation) or air circulation ensures rated performance, reliable operation, and ease of maintenance. Site restrictions may compromise minimum clearances indicated below, resulting in unpredictable airflow patterns and possible diminished performance. The unit controls will optimize operation without nuisance high-pressure safety cut-outs; however, the system designer must consider potential performance degradation. Access to the unit control center assumes the unit is no higher than on spring isolators. Recommended minimum clearances: Side to wall – 6'; rear to wall – 6'; control panel to end wall – 4'0"; top – no obstructions allowed; distance between adjacent units – 10'. No more than one adjacent wall may be higher than the unit.

# Unit Dimensions (Cont'd)

## YSAA0090HA

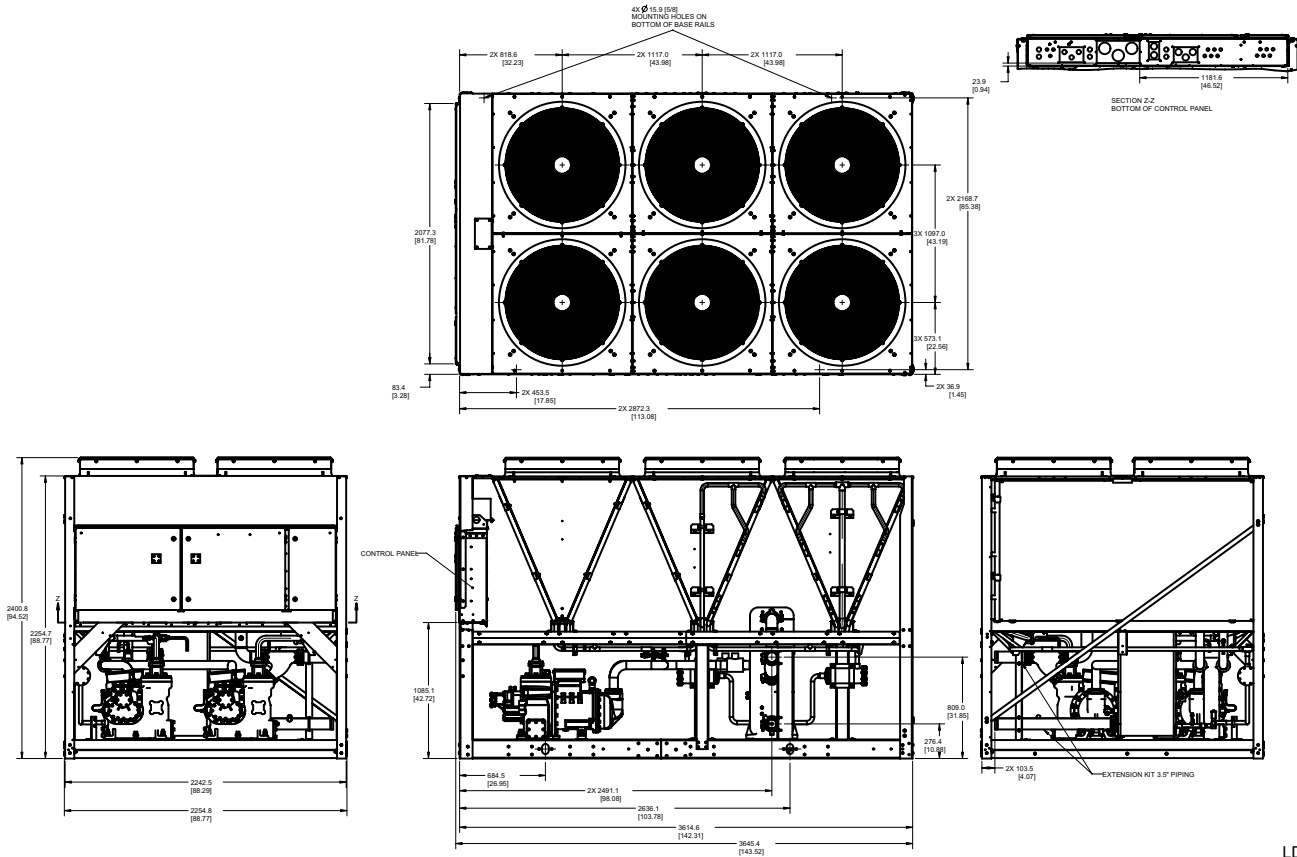

LD21005

**NOTE:**

Placement on a level surface of free of obstructions (including snow, for winter operation) or air circulation ensures rated performance, reliable operation, and ease of maintenance. Site restrictions may compromise minimum clearances indicated below, resulting in unpredictable airflow patterns and possible diminished performance. The unit controls will optimize operation without nuisance high-pressure safety cut-outs; however, the system designer must consider potential performance degradation. Access to the unit control center assumes the unit is no higher than on spring isolators. Recommended minimum clearances: Side to wall – 6"; rear to wall – 6"; control panel to end wall – 4'0"; top – no obstructions allowed; distance between adjacent units – 10'. No more than one adjacent wall may be higher than the unit.

# Unit Dimensions (Cont'd)

## YSAA0110HA

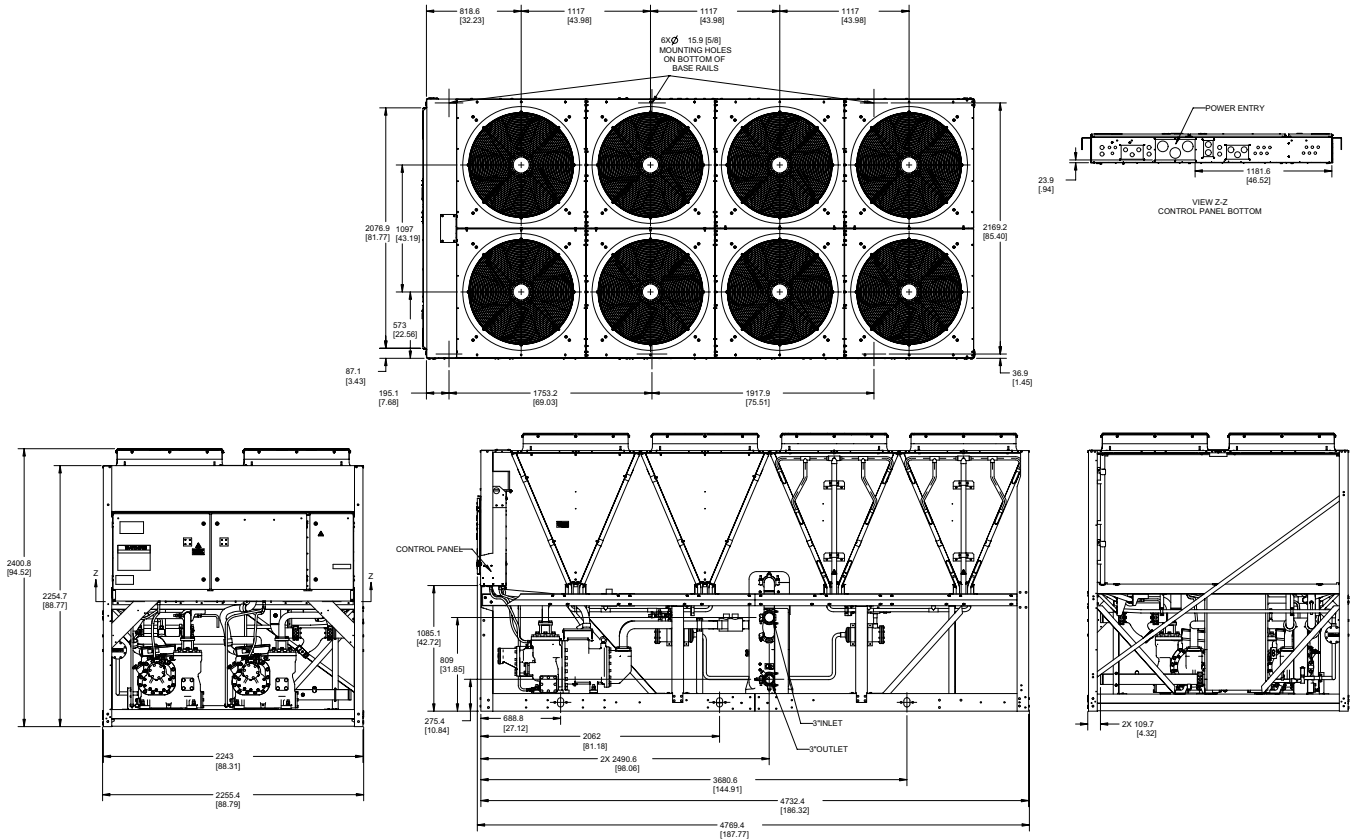

LD20510

**NOTE:**

Placement on a level surface of free of obstructions (including snow, for winter operation) or air circulation ensures rated performance, reliable operation, and ease of maintenance. Site restrictions may compromise minimum clearances indicated below, resulting in unpredictable airflow patterns and possible diminished performance. The unit controls will optimize operation without nuisance high-pressure safety cut-outs; however, the system designer must consider potential performance degradation. Access to the unit control center assumes the unit is no higher than on spring isolators. Recommended minimum clearances: Side to wall – 6'; rear to wall – 6'; control panel to end wall – 4'0"; top – no obstructions allowed; distance between adjacent units – 10'. No more than one adjacent wall may be higher than the unit.

# Isolator Locations

YSAA0070HA

## FOUR FAN ISOLATOR LOCATIONS

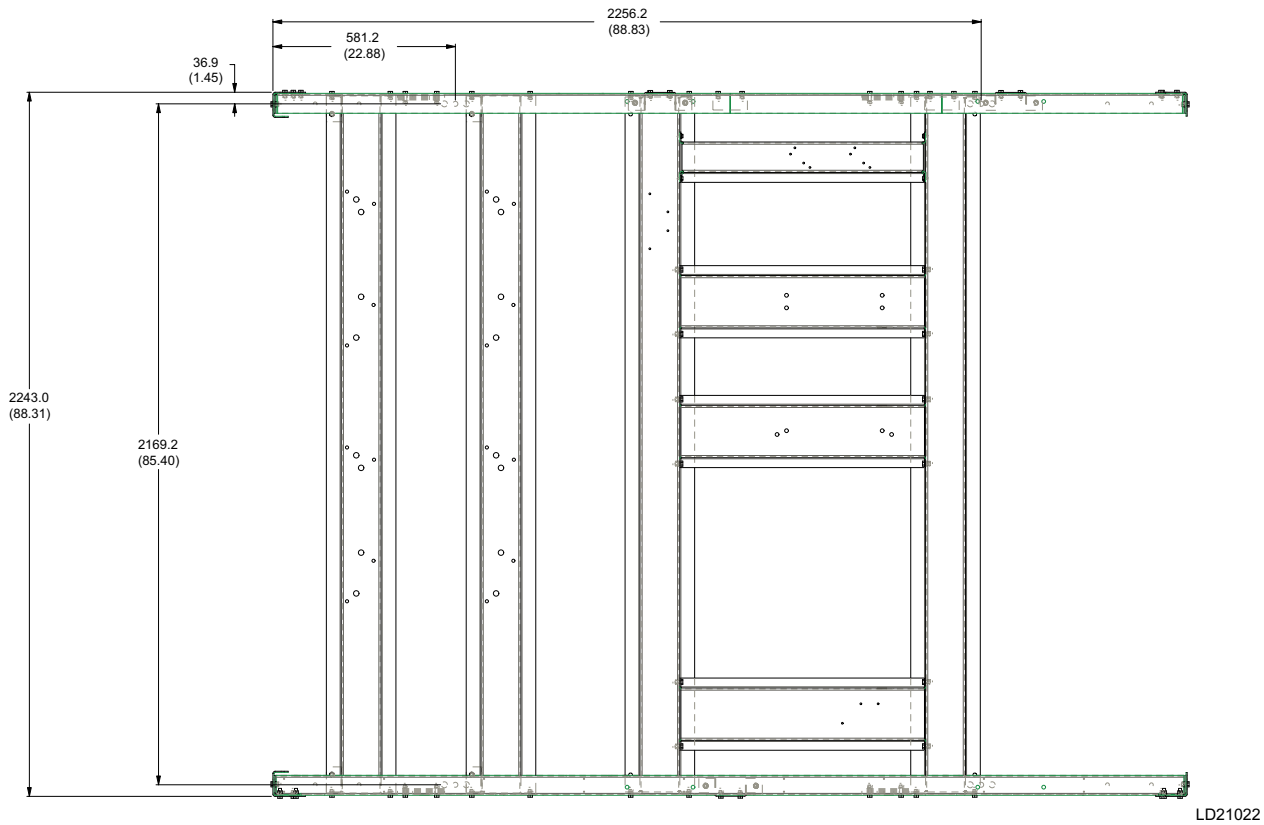

All dimensions are inches unless otherwise specified.  
Dimensions indicate isolator mounting centerlines.

# Isolator Locations (Cont'd)

YSAA0090HA

## SIX FAN ISOLATOR LOCATIONS

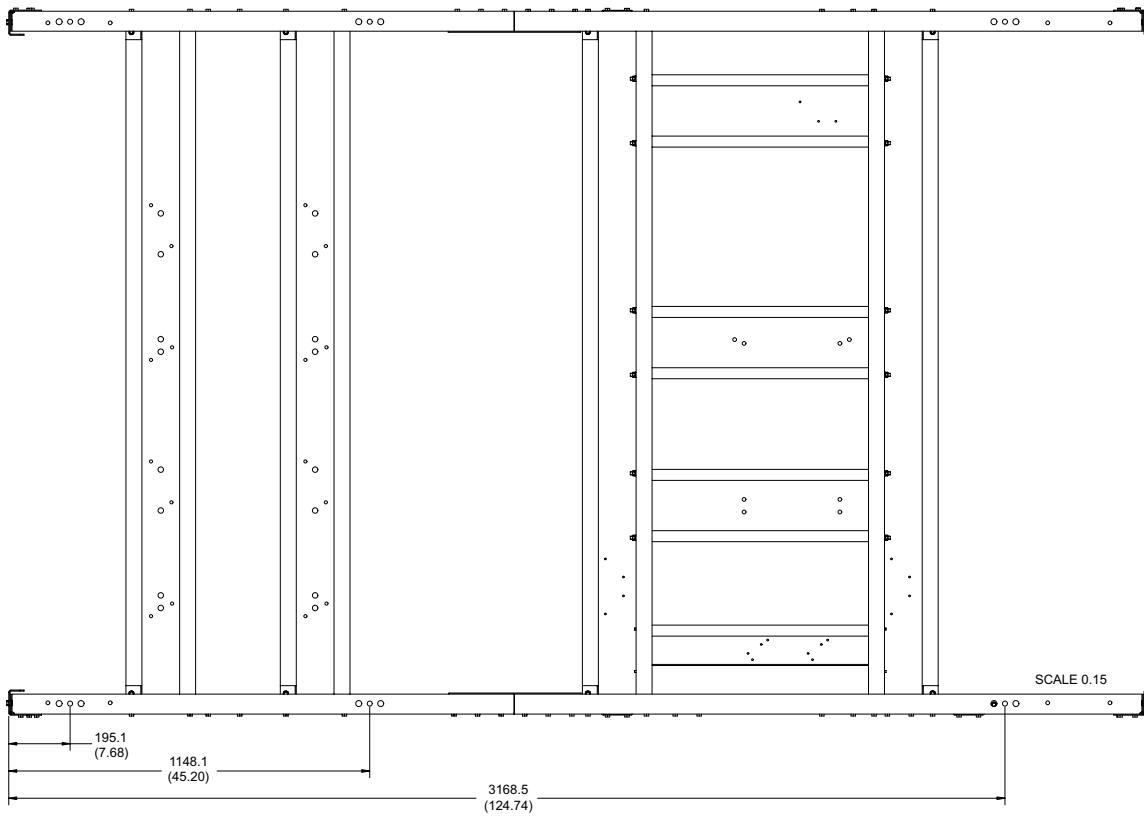

LD21023

All dimensions are inches unless otherwise specified.  
Dimensions indicate isolator mounting centerlines.

# Isolator Locations (Cont'd)

YSAA0110HA

## EIGHT FAN ISOLATOR LOCATIONS

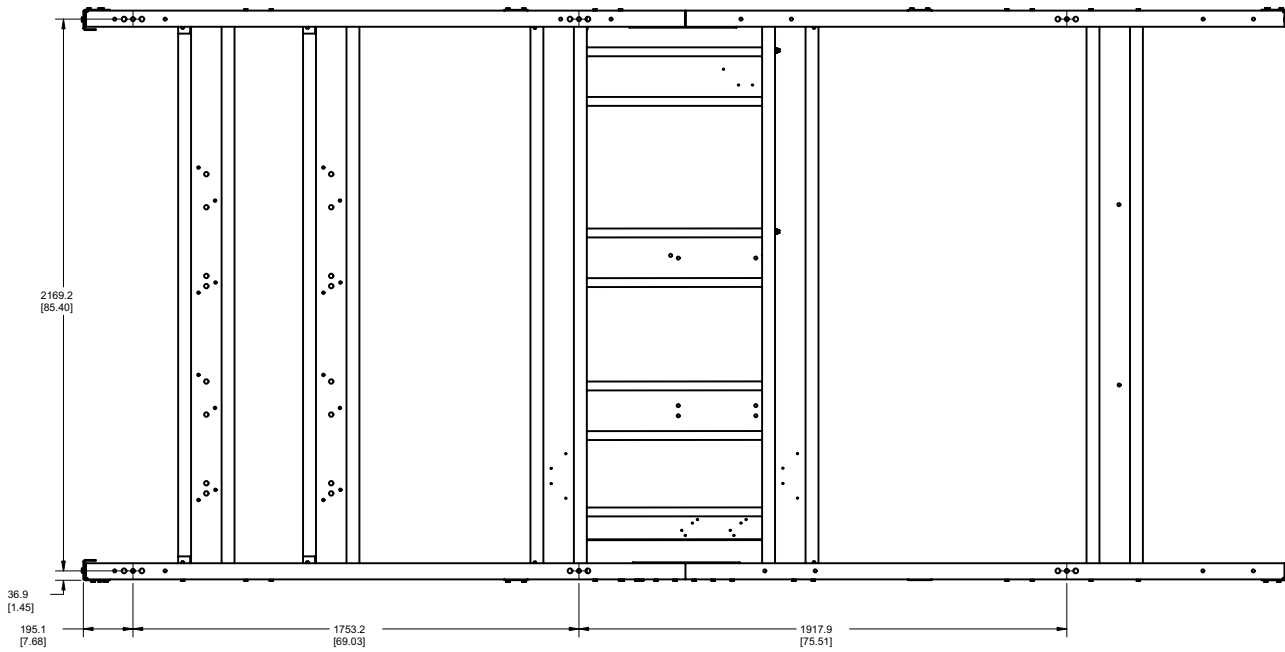

LD20511

All dimensions are inches unless otherwise specified.  
Dimensions indicate isolator mounting centerlines.

# Isolator Details

## ONE INCH DEFLECTION SPRING ISOLATOR (CPX-X-)

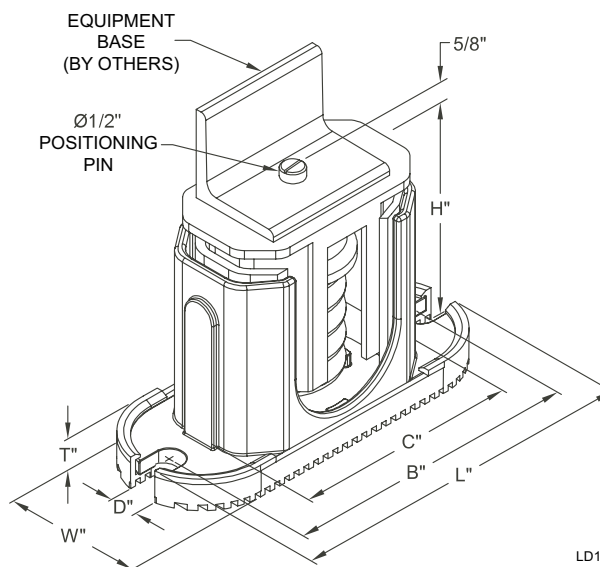

LD18443

MOUNT	DIMENSION DATA INCHES (MM)						
	W	D	L	B	C	T	H
CP1	3 (76)	0.625 (16)	7.75 (197)	6.5 (165)	4.75 (121)	0.5 (13)	4.625 (117)
CP2	3 (76)	0.625 (16)	10.5 (267)	9.25 (235)	7.75 (197)	0.5625 (14)	6 (152)

MOUNT	RATED CAPACITY LBS (KG)	DEFLECTION RATED IN (MM)	COLOR CODE
CP1-1D-85	85 (39)	1020 (463)	LT. PURPLE
CP1-1D-120	120 (54)	1.2 (30)	DK. YELLOW
CP1-1D-175	175 (79)	1.17 (30)	DK. BLUE
CP1-1D-250	250 (113)	1.4 (36)	YELLOW
CP1-1D-340	340 (154)	1.13 (29)	RED
CP1-1D-510	510 (231)	1.02 (26)	BLACK
CP1-1D-675	675 (306)	1.32 (34)	DK. PURPLE
CP1-1D-900	900 (408)	1.02 (26)	DK. GREEN
CP1-1D-1200	1200 (544)	0.9 (23)	GRAY
CP1-1D-1360	1360 (617)	0.77 (20)	WHITE
CP1-1D-1785N	1785 (810)	0.88 (22)	GRAY/RED

MOUNT	RATED CAPACITY LBS (KG)	DEFLECTION RATED IN (MM)	COLOR CODE
CP2-1D-1020	1020 (463)	1.020 (46)	BLACK
CP2-1D-1350	1350 (612)	1.32 (34)	DK. PURPLE
CP2-1D-1800	1800 (816)	1.02 (26)	DK. GREEN
CP2-1D-2400	2400 (1089)	0.9 (23)	GRAY
CP2-1D-2720	2720 (1234)	0.77 (20)	WHITE
CP2-1D-3570N	3570 (1619)	0.88 (22)	GRAY/RED

# Isolator Details (Cont'd)

## ELASTOMERIC ISOLATOR

**RD3 ISOLATORS**

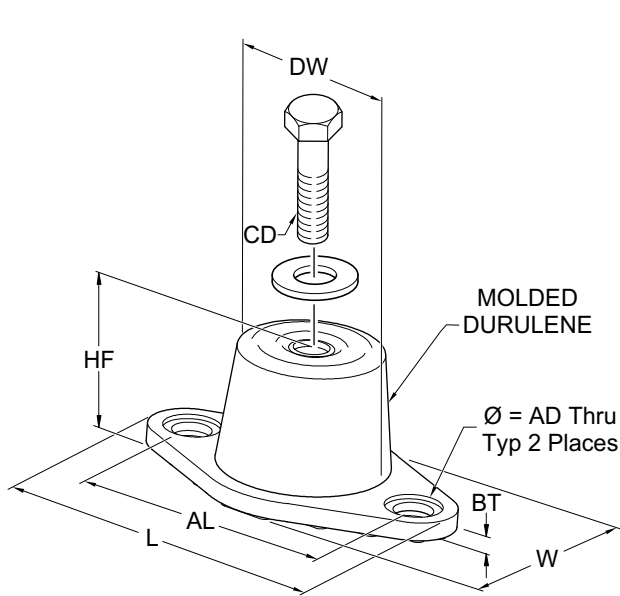

**RD4 ISOLATORS**

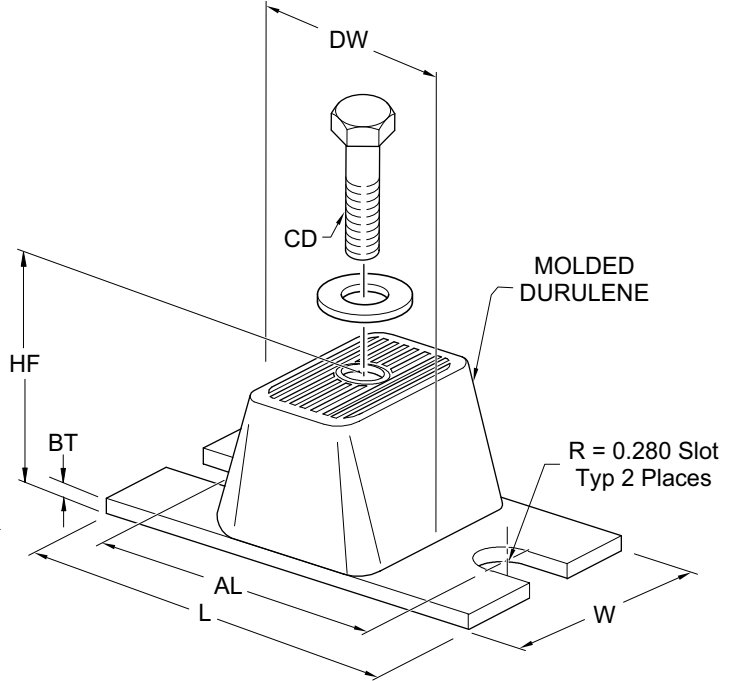

LD17304

MOUNT TYPE	DIMENSION DATA INCHES (MM)							
	L	W	HF	AL	AD	BT	CD	DW
RD3-WR	5.5 (139.7)	3.38 (85.85)	2.88 (73.15)	4.13 (104.90)	0.56 (14.22)	0.25 (6.35)	1/2-13 UNC X 1	2.5 (63.5)
RD4-WR	6.25 (158.7)	4.63 (117.60)	2.75 (69.85)	5 (127)	0.56 (14.22)	0.38 (9.65)	1/2-13 UNC X 1	3 (76.2)

RD3	RATED CAPACITY LBS (KG)	RATED DEFLECTION INCHES (MM)	DURO (± 5)
RD3-BROWN-WR	250 (113)	0.5 (12)	40
RD3-BRICK RED-WR	525 (238)	0.5 (12)	50
RD3-LIME-WR	750 (340)	0.5 (12)	60
RD3-CHARCOAL-WR	1100 (499)	0.5 (12)	70

RD4	RATED CAPACITY LBS (KG)	RATED DEFLECTION INCHES (MM)	DURO (± 5)
RD4-BROWN-WR	1500 (680)	0.5 (12)	40
RD4-BRICK RED-WR	2250 (1021)	0.5 (12)	50
RD4-LIME-WR	3000 (1361)	0.5 (12)	60
RD4-CHARCOAL-WR	4000 (1814)	0.5 (12)	70

# Electrical Notes

## NOTES:

1. Minimum Circuit Ampacity (MCA) is based on 125% of the rated load amps for the largest motor plus 100% of the rated load amps for all other loads included in the circuit, per N.E.C. Article 430-24. If the optional Factory Mounted Control Transformer is provided, add the following MCA values to the electrical tables for the system providing power to the transformer: -17, add 2.5 amps; -28, add 2.3 amps; -40, add 1.5 amps, -46, add 1.3 amps; -58, add 1 amp.
2. The minimum recommended disconnect switch is based on 115% of the rated load amps for all loads included in the circuit, per N.E.C. Article 440.
3. Minimum fuse size is based upon 150% of the rated load amps for the largest motor plus 100% of the rated load amps for all other loads included in the circuit to avoid nuisance trips at start-up due to lock rotor amps. It is not recommended in applications where brown outs, frequent starting and stopping of the unit, and/or operation at ambient temperatures in excess of 95°F (35°C) is anticipated.
4. Maximum fuse size is based upon 225% of the rated load amps for the largest motor plus 100% of the rated load amps for all other loads included in the circuit, per N.E.C. Article 440-22.
5. Circuit breakers must be UL listed and CSA certified and maximum size is based on 225% of the rated load amps for the largest motor plus 100% of the rated load amps for all other loads included in the circuit. Otherwise, HACR-type circuit breakers must be used. Maximum HACR circuit breaker rating is based on 225% of the rated load amps for the largest motor plus 100% of the rated load amps for all other loads included in the circuit.
6. The "INCOMING WIRE RANGE" is the minimum and maximum wire size that can be accommodated by the unit wiring lugs. The (2) preceding the wire range indicates the number of termination points available per phase of the wire range specified. Actual wire size and number of wires per phase must be determined based on the National Electrical Code, using copper connectors only. Field wiring must also comply with local codes.
7. A ground lug is provided for each compressor system to accommodate a field grounding conductor per N.E.C. Table 250-95. A control circuit grounding lug is also supplied.
8. The supplied disconnect is a "Disconnecting Means" as defined in the N.E.C. 100, and is intended for isolating the unit for the available power supply to perform maintenance and troubleshooting. This disconnect is not intended to be a Load Break Device.
9. Field Wiring by others which complies to the National Electrical Code & Local Codes.

## ***Electrical Notes (Cont'd)***

### **LEGEND**

ACR-LINE	ACROSS THE LINE START
C.B.	CIRCUIT BREAKER
D.E.	DUAL ELEMENT FUSE
DISC SW	DISCONNECT SWITCH
FACT MOUNT CB	FACTORY MOUNTED CIRCUIT BREAKER
FLA	FULL LOAD AMPS
HZ	HERTZ
MAX	MAXIMUM
MCA	MINIMUM CIRCUIT AMPACITY
MIN	MINIMUM
MIN NF	MINIMUM NON FUSED
RLA	RATED LOAD AMPS
S.P. WIRE	SINGLE POINT WIRING
UNIT MTD SERV SW	UNIT MOUNTED SERVICE (NON-FUSED DISCONNECT SWITCH)
LRA	LOCKED ROTOR AMPS

### **VOLTAGE CODE**

-40 = 380-3-60

## Wiring Lugs

YSAA	GLOBAL MARKET		STANDARD FAN			
			TERMINAL BLOCK		CIRCUIT BREAKER	
	VOLTS	HZ	WIRE PER LUG	LUG WIRE RANGE	WIRE PER LUG	LUG WIRE RANGE
0070	230	60	2	#6 - 500 kcmil	2	250 - 500 kcmil
	380	60	1	#6 - 500 kcmil	2	3/0-250 kcmil
0090	230	60	2	#6 - 500 kcmil	2	250 - 500 kcmil
	380	60	2	#6 - 500 kcmil	2	250 - 500 kcmil
0110	230	60	4	4/0 - 500 kcmil	4	4/0 - 500 kcmil
	380	60	2	#2 - 500 kcmil	2	250 - 500 kcmil

**NOTE:** Alternate lugs are provided in the panel for field electricians and contractors, should there be a need for other lug arrangements that the installed lugs on the non-fused disconnect switch and circuit breaker panels.

**Electrical Data Without Pumps**

YSAA	VOLT	HZ	MCA	MIN N/F DISC SW	MIN DUAL ELEM FUSE & CB	MAX DUAL ELEM CB	COMPR 1		COMPR 2		STD FLOW FANS		
							RLA	LRA	RLA	LRA	QTY	FLA	LRA
0070	230	60	358	500	500	500	142.1	935	142.1	935	4	7.4	37
	380	60	215	300	300	300	85.3	405	85.3	405	4	4.5	23.1
0090	230	60	466	600	600	600	183.6	1075	183.6	1075	6	7.4	37
	380	60	268	350	350	350	104.8	510	104.8	510	6	4.5	23.1
0110	230	60	607	800	800	800	239.7	1261	239.7	1261	8	7.4	37
	380	60	354	450	450	450	138.9	665	138.9	665	8	4.5	23.1

THIS PAGE INTENTIONALLY LEFT BLANK.

# Wiring Diagram

## ELEMENTARY DIAGRAM CONTROL CIRCUIT

- LEGEND**
- △ XTBC1 - TERMINAL BLOCK FOR CUSTOMER CONNECTIONS
  - XTBC2
  - TS TRANSIENT VOLTAGE SUPPRESSION
  - WIRING AND COMPONENTS BY YORK
  - OPTIONAL EQUIPMENT
  - WIRING AND/OR COMPONENTS BY OTHERS

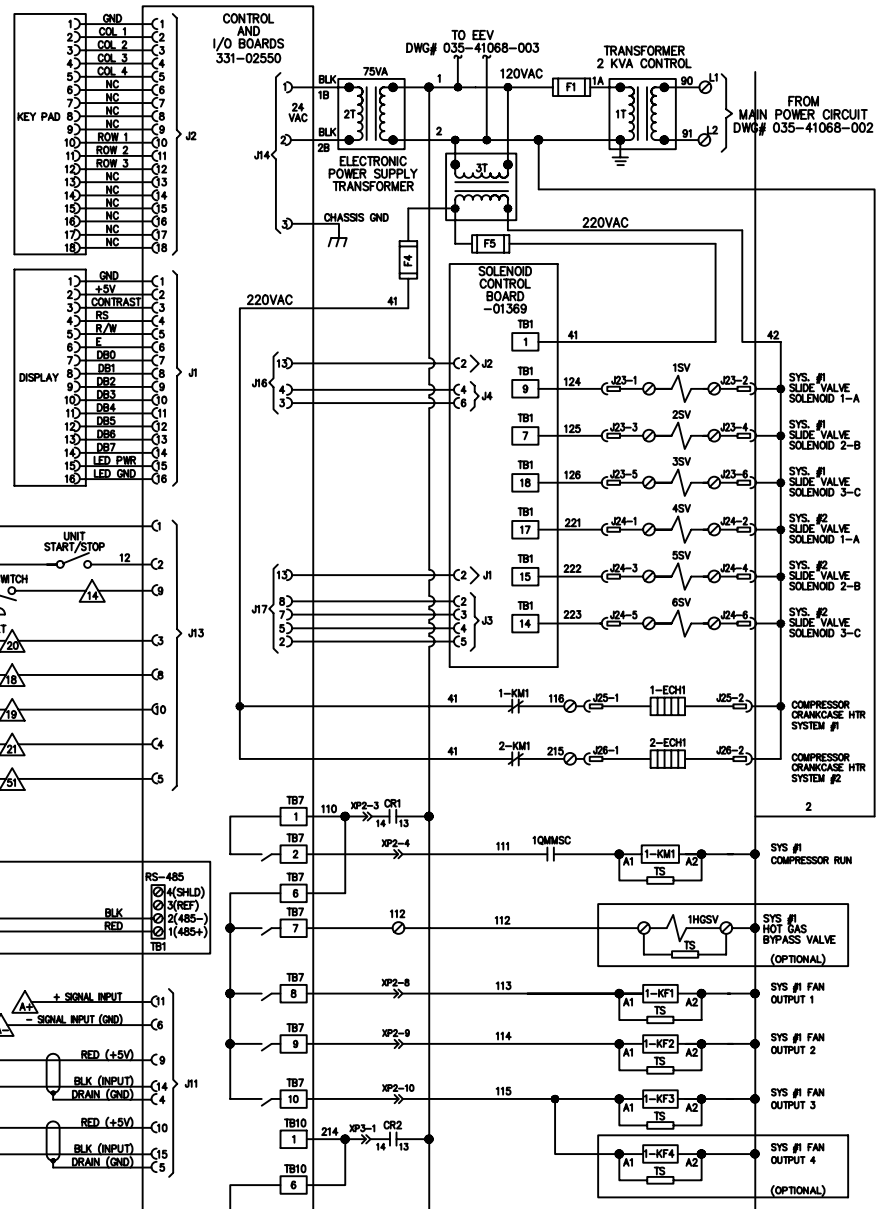
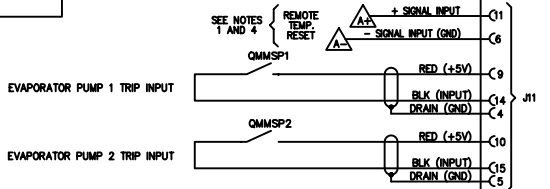
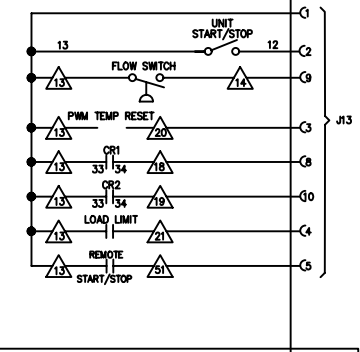
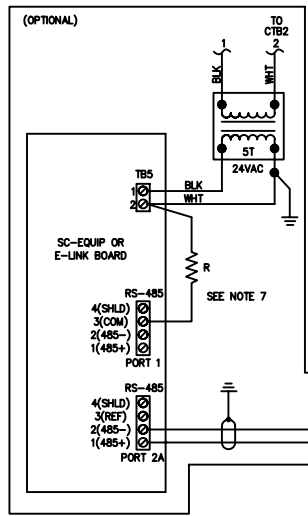
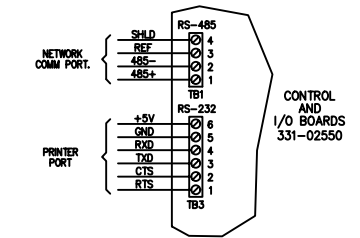

LD20511a

# Wiring Diagram (Cont'd)

035-41068-001 REV A

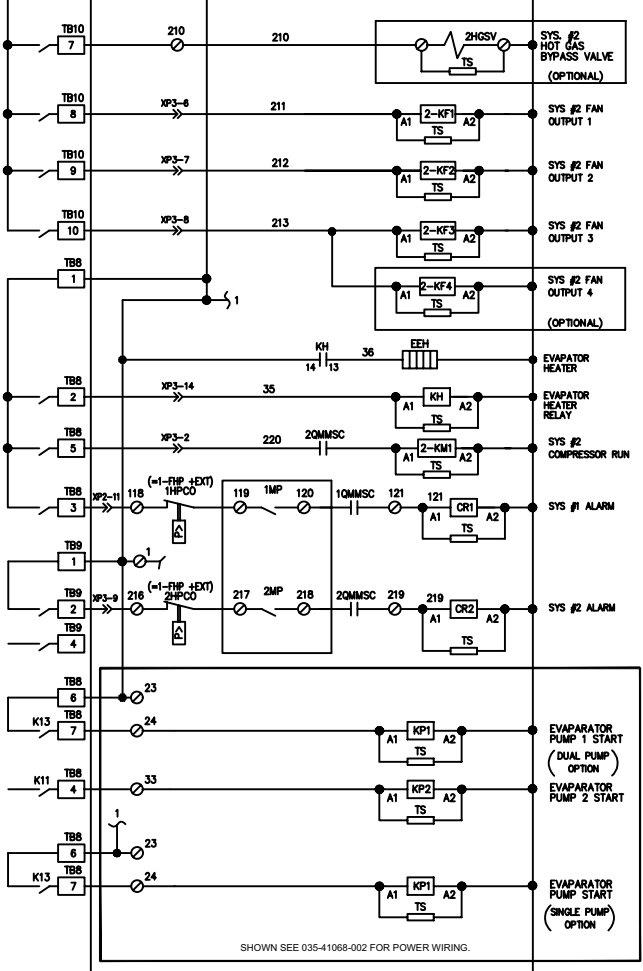

SHOWN SEE 035-41068-002 FOR POWER WIRING.

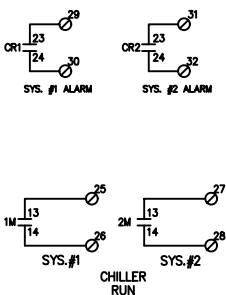
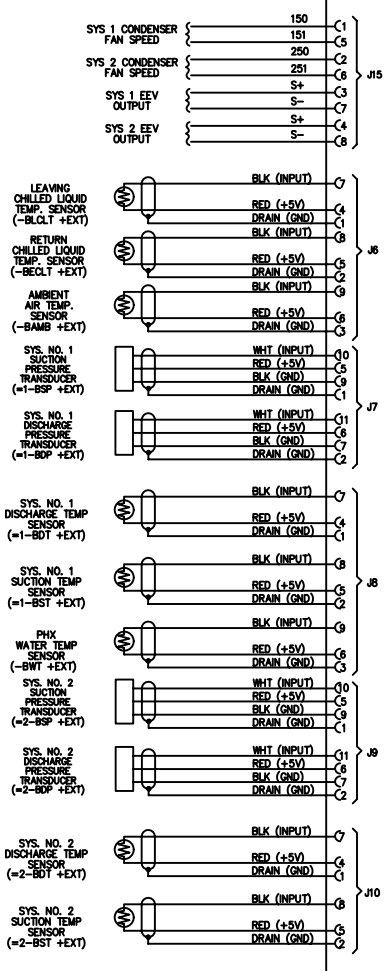

1. FIELD WIRING TO BE IN ACCORDANCE WITH THE CURRENT EDITION OF THE NATIONAL ELECTRICAL CODE AS WELL AS ALL OTHER APPLICABLE CODES AND SPECIFICATIONS.
2. CONTACTS MUST BE SUITABLE FOR SWITCHING 115VAC AT 5 MA.
3. CONTACTS ARE RATED AT 115V, 100VA, RESISTIVE LOAD ONLY, AND MUST BE SUPPRESSED AT LOAD BY USER.
4. SEE INSTALLATION, OPERATION AND MAINTENANCE MANUAL WHEN FEEDING ANALOG SIGNAL FOR REMOTE TEMP. RESET.
5. WIRING BY OTHERS ON REMOTE EVAP. UNITS
- 6.
7. RESISTOR INSTALLED WHEN BAS RS485 2-WIRE CONNECTION IS REQUIRED.

# Wiring Diagram (Cont'd)

Designation	DESCRIPTION
ACC	ACCESSORY
- ADIS	DISPLAY BOARD
- AMB	MICRO BOARD

- BAMB	AMBIENT
- BDP	DISCHARGE PRESSURE
- BECT	ENTERING CHILLED TEMP
- BLCT	LEAVING CHILLED TEMPERATURE
NOT FITTED ON REMOTE EVAP UNITS	

-BMP	MOTOR PROTECTOR COMP
- BSP	SUCTION PRESSURE

-CPF	CAPACITOR POWER FACTOR
------	------------------------

- ECH	CRANKCASE HEATER
-EEH	EVAPORATOR HEATER
-EPH	PUMP HEATER
-EXT	EXTERNAL TO CONTROL PANEL

- F	FUSE
- FHP	HIGH PRESSURE CUTOOUT
-FSI	FAN SPEED INHIBIT TWO SPEED FAN OPTION ONLY

GND	GROUND
G/Y	GREEN / YELLOW

J	PLUG BOARD CONNECTOR
---	----------------------

-K	CIRCUIT BOARD RELAY
-KF	FAN CONTACTOR LINE
-KFH	FAN CONTACTOR HIGH SPEED (INCLUDING COIL SUPPRESSOR)
-KFL	FAN CONTACTOR LOW SPEED (INCLUDING COIL SUPPRESSOR)
-KFOL	FAN OVERLOAC
-KFS	RELAY FAN SPEED
-KM	COMPRESSOR CONTACTOR (INCLUDING COIL SUPPRESSOR)
-KCR	CONTROL RELAY
-KP	PUMP CONTACTOR PART (INCLUDING COIL SUPPRESSOR)

- M	COMPRESSOR MOTOR
-MF	MOTOR FAN
-MP	MOTOR PUMP

NU	NOT USED
----	----------

PE	PROTECTIVE EARTH
PWM	PULSE WIDTH MODULATION TEMP RESET or REMOTE UNLOAD 2nd STEP

Designation	DESCRIPTION
-QCB	CIRCUIT BREAKER
-QMMSC	MANUAL MOTOR STARTER COMP
-QMMSP	MANUAL MOTOR STARTER PUMP
-QSD	SWITCH DISCONNECT

R	RESISTOR
RED	RED
RP	RUN PERMISSIVE
RU	REMOTE UNLOAD 1st STEP

CR	SCREEN
- SF	FLOW SWITCH
- SKP	KEYPAD
- SOA	SWITCH OFF AUTO

- T	TRANSFORMER
-TC	TRANSFORMER CURRENT

-UBR	BRIGDE RECIFIER
------	-----------------

WHT	WHITE
-----	-------

- XTBC	TERMINAL BLOCK CUSTOMER
- XTBF	TERMINAL BLOCK FACTORY

-YHGSV	HOT GAS SOLENOID VALVE (INCLUDING COIL SUPPRESSOR)
- YLLSV	LIQUID LINE SOLENOID VALVE (INCLUDING COIL SUPPRESSOR)
FIELD MOUNTED AND WIRED ON REMOTE EVAP UNITS	

- ZCPR	COMPRESSOR
--------	------------

	NOTE WELL {SEE NOTE}
---	----------------------

	WIRING AND ITEMS SHOWN THUS ARE STANDARD YORK ACCESSORIES
---	--

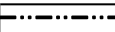
	WIRING AND ITEMS SHOWN THUS ARE NOT SUPPLIED BY JOHNSON CONTROLS
---	---

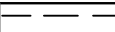
	ITEMS THUS ENCLOSED FORM A COMPONENTS OR SETS OFCOMPONENTS
---	---

## Wiring Diagram (Cont'd)

- A. This drawing is based on IEC symbols.
  - B. Field wiring to be in accordance with the relevant electrical code as well as all other applicable codes and specifications
  - C. All sources of supply shown on this diagram to be taken from one main isolator, not shown or supplied by the chiller manufacturer .
  - D. Green and yellow wire is used for earth, multi-coloured cable used for low voltage. Red wire used for AC control, blue wire for neutral, black wire for AC and DC power. Orange wire should be used for interlock control wiring supplied by external source.
  - E. Legend designation depicts component abbreviations. Number prefix located, if applicable, on schematic circuit, refers to system thereon, e.g.= 1-FHP2 refers to high pressure cutout no 2 on system no 1.
  - F. All wiring to control section voltage free contacts requires a supply provided by the customer maximum voltage 240 volts. The customer must take particular care when deriving the supplies for the voltage free terminals with regard to a common point of isolation. Thus, these circuits when used must be fed via the common point of isolation the voltage to these circuits is removed when the common point of isolation to the unit is opened. This common point of isolation is not supplied. The voltage free contacts are rated at 100VA. All inductive devices {relays} switch by the voltage free contacts must have their coil suppressed using standard r/c suppressors.
  - G. Customer voltage free contacts connected to terminal 13 must be rated at 30v 5ma
  - H. No controls {relays etc.} Should be mounted in any section of the control panel. Additionally, control wiring not connected to the control panel should not be run through the panel. If these precautions are not followed, electrical noise could cause malfunctions or damage to the unit and its controls.
1. Refer to instalation commisioning operation and maintenance manual for customer connections and customer connection notes, non compliance to these instructions will invalidate unit warranty.
  2. Wiring and components for compressor 3 only fitted when unit has 3 compressors on the system. 1-BMP3 is replaced by a link across terminals 134 & 135. 2-BMP3 is replaced by a link across terminals 234 & 235.
  3. FHP2 is only fitted on 0089 and above. When not fitted 1-FHP2 is replaced by a link across terminals 132 & 139. 2-FHP2 is replaced by a link across terminals 232 & 239
  4. Fitted on units with hot gas bypass option.
  5. EMS option is wired as shown
  6. This wiring must be used for old display 031-0110-000
  7. Network connection point
  8. Printer port
  9. Remote emergency stop can be wired between terminal 1 and 5 after removing link
  10. Power factor correction accessory. Power factor correction fitted to each compressor contactor
  11. Not fitted on compressors with internal motor protection. For sytem 1 terminals 132 & 133, 133 & 134 And 134 & 135 are linked. For sytem 2 terminals 232 & 233, 233 & 234 and 234 & 235 are linked.
  12. Only fitted on systems with 3 or 4 fans
  13. Only fitted on systems with 4 fans
  14. Only fitted on systems with 5 fans
  15. Only fitted on systems with 6 fans
  16. Input switch disconnect or circuit breaker option replaces input terminal block
  17. Input switch disconnect & system circuit breaker option replaces input terminal block
  18. 115V control circiut requires a 115V supply unless control circuit transformer-T2 & -F3 are fitted
  19. For optional hydro kit. Heater -EPH is fitted and wired as shown. On sinlge pump -KP1, -QMMSP1 and -MP1 are fitted & wired as shown. On two pump hydro kits -KP2, -QMMSP2 & -MP2 are also fitted and wired as shown.
  20. Current measurement option wired as shown
  21. Only fitted on systems with single speed fans
  22. Only fitted on systems with two speed fans
  23. Optional compressor manual motors starters.
  24. See sheet 3 of connection diagram for power input options

# User Control Wiring

## USER CONTROL WIRING INPUTS

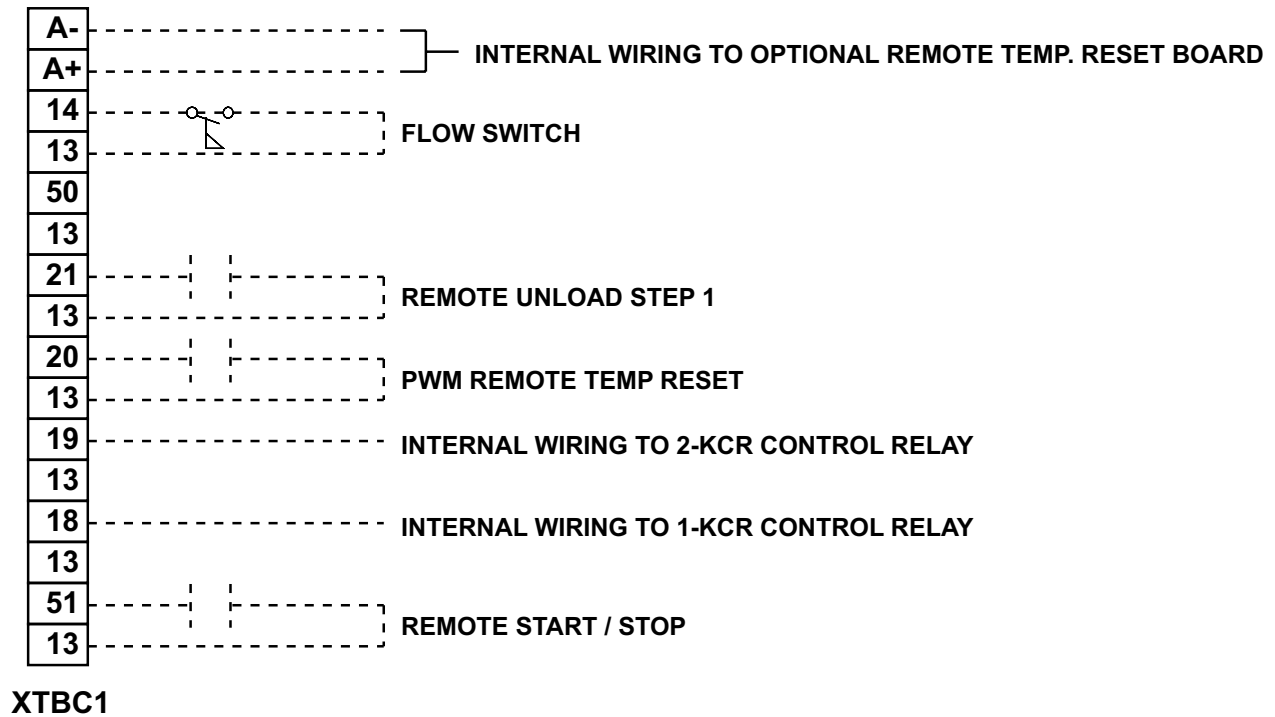

## USER CONTROL WIRING OUTPUTS

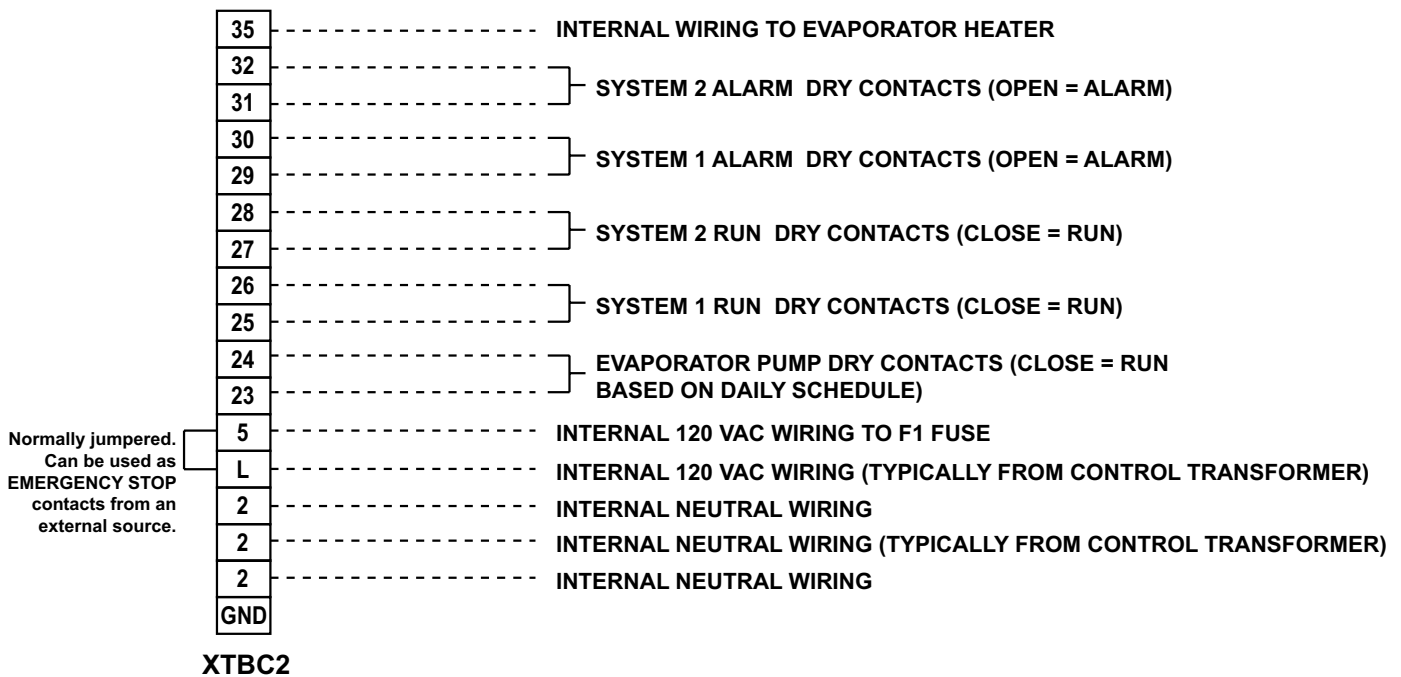

## Application Data

### UNIT LOCATION

The YSAA chillers are designed for outdoor installation. When selecting a site for installation, be guided by the following conditions:

- A. For outdoor locations of the unit, select a place having an adequate supply of fresh air for the condenser.
- B. Avoid locations beneath windows or between structures where normal operating sounds may be objectionable.
- C. Installation sites may be either on a roof, or at ground level. (See FOUNDATION.)
- D. The condenser fans are the propeller-type, and are not recommended for use with duct work in the condenser air stream.
- E. When it is desirable to surround the unit(s), it is recommended that the screening be able to pass the required chiller CFM without exceeding 0.1" of water external static pressure.
- F. Protection against corrosive environments is available by supplying the units with epoxy coating on the condenser coils. The epoxy coils should be offered with any units being installed at the seashore or where salt spray may hit the unit.

In installations where winter operation is intended and snow accumulations are expected, additional height must be provided to ensure normal condenser air flow.

Recommended clearances for units are given in Dimensions. When the available space is less, the unit(s) must be equipped with the discharge pressure transducer option to permit high pressure unloading in the event that air recirculation were to occur.

### FOUNDATION

The unit should be mounted on a flat and level foundation, ground or roof, capable of supporting the entire operating weight of the equipment. Operating weights are given in the *Physical Data and Nominal Ratings on page 19*.

**Roof Locations** – Choose a spot with adequate structural strength to safely support the entire weight of the unit and service personnel. Care must be taken not to damage the roof during installation. If the roof is “bonded”, consult the building contractor or architect for special installation requirements. Roof installations should incorporate the use of spring-type isolators to minimize the transmission of vibration into the building structure.

**Ground Level Installations** – It is important that the units be installed on a substantial base that will not settle, causing strain on the liquid lines and resulting in possible leaks. A one-piece concrete slab with footers extending below the frost line is highly recommended. Additionally, the slab should not be tied to the main building foundation as noises will telegraph.

Mounting holes (5/8" diameter) are provided in the steel channel for bolting the unit to its foundation. See *Unit Dimensions on page 23*.

## ***Application Data (Cont'd)***

For ground level installations, precautions should be taken to protect the unit from tampering by or injury to unauthorized persons. Screws on access panels will prevent casual tampering; however, further safety precautions, such as unit enclosure options, a fenced-in enclosure, or locking devices on the panels may be advisable. Check local authorities for safety regulations.

### **VARIABLE PRIMARY FLOW**

Johnson Controls recommends a maximum 10% per minute flow rate of change, based on design flow, for variable primary flow applications. Eight to 10 gallons per chiller ton (8.6 to 10.8 liter per cooling kW) is recommended for the system liquid volume. Insufficient system volume and rapid flow changes can cause control problems or can even cause chiller shutdowns. There are many other design issues to evaluate with variable primary flow systems. Consult your Johnson Controls Sales Office for more information about successfully applying YSAA chillers.

### **CHILLED LIQUID PIPING**

The chilled liquid piping system should be laid out so that the circulating pump discharges into the evaporator. The inlet and outlet evaporator liquid connections are given in *Unit Dimensions on page 23*.

Hand stop valves are recommended for use in all lines to facilitate servicing. Drain connections should be provided at all low points to permit complete drainage of the evaporator and system piping. Additionally, a strainer (20 mesh) is recommended for use on the INLET line to the evaporator.

Pressure gauge connections are recommended for installation in the inlet and outlet water lines. Gauges are not furnished with the unit and are to be furnished by other suppliers.

The chilled liquid lines that are exposed to outdoor ambients should be wrapped with a supplemental heater cable and covered with insulation. As an alternative, ethylene glycol should be added to protect against freeze-up during low ambient periods.

A flow switch is available as an accessory on all units. The flow switch (or its equivalent) must be installed in the leaving water piping of the evaporator and must not be used to start and stop the unit.

# Guide Specifications

## PART 1 – GENERAL

### 1.01 SCOPE

- A. The requirements of this Section shall conform to the general provisions of the Contract, including General and Supplementary Conditions, Conditions of the Contract, and Contract Drawings.
- B. Provide microprocessor-controlled, multiple-screw compressor, air-cooled, liquid chillers of the scheduled capacities as shown and indicated on the drawings, including but not limited to:
  - 1. Chiller package with zero ozone depletion potential Refrigerant R-134A
  - 2. Electrical power and control connections
  - 3. Chilled water connections
  - 4. Manufacturer start-up
  - 5. Charge of refrigerant and oil.

### 1.02 QUALITY ASSURANCE

- A. Products shall be Designed, Tested, Rated and Certified in accordance with, and Installed in compliance with applicable sections of the following Standards and Codes:
  - 1. AHRI 550/590 and 551/591– Water Chilling Packages Using the Vapor Compression Cycle
  - 2. AHRI 370 – Sound Rating of Large Outdoor Refrigerating and Air-Conditioning Equipment
  - 3. ANSI/ASHRAE 15 – Safety Code for Mechanical Refrigeration
  - 4. ANSI/ASHRAE 34 – Number Designation and Safety Classification of Refrigerants
  - 5. ASHRAE 90.1 – Energy Standard for Buildings Except Low-Rise Residential Buildings
  - 6. ANSI/NFPA 70 – National Electrical Code (N.E.C.)
  - 7. ASME Boiler and Pressure Vessel Code, Section VIII, Division 1
  - 8. OSHA – Occupational Safety and Health Act
  - 9. Manufactured in facility registered to ISO 9001
  - 10. Conform to Intertek Testing Services for construction of chillers and provide ETL/cETL Listed Mark

## Guide Specifications (Cont'd)

- B. Factory Run Test: Chiller shall be pressure-tested, evacuated and fully charged with refrigerant and oil, and shall be factory operational run tested with water flowing through the vessel.
- C. Chiller manufacturer shall have a factory trained and supported service organization.
- D. Warranty: Manufacturer shall Warrant all equipment and material of its manufacture against defects in workmanship and material for a period of eighteen (18) months from date of shipment or twelve (12) months from date of start-up, whichever occurs first.

### 1.03 DELIVERY AND HANDLING

- A. Unit shall be delivered to job site fully assembled with all interconnecting refrigerant piping and internal wiring ready for field installation and charged with refrigerant and oil by the Manufacturer.
- B. Provide protective covering over vulnerable components for unit protection during shipment. Fit nozzles and open ends with plastic enclosures.
- C. Unit shall be stored and handled per Manufacturer's instructions.

## PART 2 - PRODUCTS

### 2.01 CHILLER MATERIALS AND COMPONENTS

- A. General: Install and commission, as shown on the schedules and plans, factory assembled, charged, and tested air cooled screw compressor chiller(s) as specified herein. Chiller shall be designed, selected, and constructed using a refrigerant with Flammability rating of "1", as defined by ANSI/ASHRAE STANDARD 34 Number Designation and Safety Classification of Refrigerants. Chiller shall include not less than two refrigerant circuits above 50 tons (200kW), screw compressors, brazed plate type evaporator, air-cooled condenser, refrigerant, lubrication system, interconnecting wiring, safety and operating controls including capacity controller, control center, motor starting components, and special features as specified herein or required for safe, automatic operation.
- B. Cabinet: External structural members shall be constructed of heavy gauge, galvanized steel coated with baked on powder paint which, when subject to ASTM B117, 1000 hour, 5% salt spray test, yields minimum ASTM 1654 rating of "6".
- C. Operating Characteristics: Provide high ambient temperature control options as required to ensure unit is capable of operation from 30°F to 115°F (-1°C to 46°C) ambient temperature.
- D. Service Isolation valves: Discharge (ball type) isolation valves factory installed per refrigerant circuit.
- E. Includes a system high-pressure relief valve in compliance with ASHRAE15.
- F. Pressure Transducers and Readout Capability
  1. Discharge Pressure Transducers: Permits unit to sense and display discharge pressure.
  2. Suction Pressure Transducers: Permits unit to sense and display suction pressure.

## Guide Specifications (Cont'd)

3. High Ambient Control: Allows units to operate when the ambient temperature is above 115°F (46°C). Includes discharge pressure transducers.

### 2.02 COMPRESSORS

- A. Compressor Motors: Refrigerant suction-gas cooled accessible hermetic compressor motor, full suction gas flow through mesh screen, with inherent internal thermal overload protection and external current overload on all three phases.
- B. Balancing Requirements: All rotating parts shall be statically and dynamically balanced.
- C. Lubrication System: External oil separators with no moving parts, 290 psig (20 barg) design working pressure, and ETL listing shall be provided on the chiller. Refrigerant system differential pressure shall provide oil flow through service replaceable, full flow, cartridge type oil filter internal to compressor. Filter bypass, less restrictive media, or oil pump not acceptable.
- D. Capacity Control: Compressors shall start at minimum load. Provide Microprocessor control to command compressor capacity to balance compressor capacity with cooling load.

### 2.03 REFRIGERANT CIRCUIT COMPONENTS

Each refrigerant circuit shall include: a discharge service ball type isolation valve, high side pressure relief, liquid line shutoff valve with charging port, low side pressure relief device, filter-drier, solenoid valve, sight glass with moisture indicator, thermostatic expansion valves [**Option:** electronic expansion valves], and flexible, closed-cell foam insulated suction line and suction pressure transducer.

### 2.04 HEAT EXCHANGERS

- A. Evaporator :
  1. Evaporator shall be brazed-plate stainless steel construction capable of refrigerant working pressure of 235 psig (16 barg) and liquid side pressure of 150 psig (10 barg).
  2. Brazed plate heat exchangers shall be UL listed.
  3. Exterior surfaces shall be covered with 3.4" (19mm), flexible, closed cell insulation, thermal conductivity of 0.26k ([BTU/ HR-Ft2 -°F]/in.) maximum.
  4. Water nozzles shall be provided with grooves for field provided ANSI/AWWA C-606 mechanical couplings.
  5. Evaporator shall include vent and drain fittings and thermostatically controlled heaters to protect to -20°F (-29°C) ambient in off-cycle.
  6. A 20 mesh, serviceable wye-strainer and mechanical couplings shall be provided for field installation on evaporator inlet prior to startup.

## Guide Specifications (Cont'd)

### B. Air Cooled Condenser:

1. Coils: Condenser coils shall be constructed of a single material to avoid galvanic corrosion due to dissimilar metals. Coils and headers are brazed as one piece. Integral sub cooling is included. Coils shall be designed for a design working pressure of 350 PSIG (24 barg).
2. Low Sound Fans: Shall be dynamically and statically balanced, direct drive, corrosion resistant glass fiber reinforced composite blades molded into a low noise, full-airfoil cross section, providing vertical air discharge and low sound. Each fan shall be provided in an individual compartment to prevent crossflow during fan cycling. Guards of heavy gauge, PVC (polyvinyl chloride) coated or galvanized steel shall be factory installed.
3. Fan Motors: High efficiency, direct drive, 6 pole, 3 phase, insulation class "F", current protected, Totally Enclosed Air-Over (TEAO), rigid mounted, with double sealed, permanently lubricated, ball bearings.

### 2.05 CONTROLS

A. General: Automatic start, stop, operating, and protection sequences across the range of scheduled conditions and transients.

B. Power/Control Enclosure: Rain and dust tight NEMA 3R powder painted steel cabinet with hinged, latched, and gasket sealed door.

### C. Microprocessor Control Center:

1. Automatic control of compressor start/stop, anti-coincidence and anti-recycle timers, automatic pumpdown at system shutdown, condenser fans, evaporator pump, evaporator heater, unit alarm contacts, and chiller operation from 30°F to 125°F (-1°C to 52°C) ambient. Automatic reset to normal chiller operation after power failure.
2. Remote water temperature reset via 0-10 VDC or 4-20 mA input signal or up to two steps of demand (load) limiting.
3. Software stored in non-volatile memory, with programmed setpoints retained in lithium-battery -backed real-time-clock (RTC) memory for minimum 5 years.
4. Forty character liquid crystal display, descriptions in English, numeric data in English (or Metric) units. Sealed keypad with sections for Setpoints, Display/Print, Entry, Unit Options & clock, and On/Off Switch.
5. Programmable Setpoints (within Manufacturer limits): display language; chilled liquid temperature setpoint and range, remote reset temperature range, daily schedule/holiday for start/stop, manual override for servicing, low and high ambient cut-outs, low liquid temperature cut-out, low suction pressure cut-out, high discharge pressure cut-out, anti-recycle timer (compressor start cycle time), and anti-coincident timer (delay compressor starts).

## Guide Specifications (Cont'd)

6. Display Data: Return and leaving liquid temperatures, low leaving liquid temperature cut-out setting, low ambient temperature cut-out setting, outdoor air temperature, English or metric data, suction pressure cut-out setting, each system suction pressure, discharge pressure (optional), liquid temperature reset via a 4-20 milliamp or 0-10 VDC input, anti-recycle timer status for each compressor, anti-coincident system start timer condition, compressor run status, no cooling load condition, day, date and time, daily start/stop times, holiday status, automatic or manual system lead/lag control, lead system definition, compressor starts/operating hours (each), status of hot gas valves, evaporator heater and fan operation, run permissive status, number of compressors running, liquid solenoid valve status, load & unload timer status, water pump status.
  7. System Safeties: Shall cause individual compressor systems to perform auto shut down; manual reset required after the third trip in 90 minutes. System Safeties include: high discharge pressure, low suction pressure, high pressure switch, and motor protector. Compressor motor protector shall protect against damage due to high input current or thermal overload of windings.
  8. Unit Safeties: Shall be automatic reset and cause compressors to shut down if low ambient, low leaving chilled liquid temperature, under voltage, and flow switch operation.
  9. Alarm Contacts: Low ambient, low leaving chilled liquid temperature, low voltage, low battery, and (per compressor circuit): high discharge pressure, and low suction pressure.
  10. BAS Communications: YORKTalk 2, BACnet MS/TP, Modbus and N2 communication capabilities are standard. (Option: LON communication via ELink Microgateway)
- D. Manufacturer shall provide any controls not listed above, necessary for automatic chiller operation. Mechanical Contractor shall provide field control wiring necessary to interface sensors to the chiller control system.

### 2.06 POWER CONNECTION AND DISTRIBUTION

#### A. Power Panels:

1. NEMA 3R raintight, powder painted steel cabinets with hinged, latched, and gasket sealed outer doors. Provide main power connection(s), control power connections, compressor and fan motor start contactors, current overloads, and factory wiring.
  2. Power supply shall enter unit at a single location, be 3 phase of scheduled voltage, and connect to individual terminal blocks per compressor. Separate disconnecting means and/or external branch circuit protection (by Contractor) required per applicable local or national codes.
- B. Compressor, control and fan motor power wiring shall be located in an enclosed panel or routed through liquid tight conduit.

## Guide Specifications (Cont'd)

### 2.07 ACCESSORIES AND OPTIONS

Some accessories and options supercede standard product features. Your Johnson Controls representative will be pleased to provide assistance.

- A. Microprocessor controlled, Factory installed Across-the-Line type compressor motor starters as standard.
- B. Outdoor Ambient Temperature Control
1. Low Ambient Control: Permits unit operation to 0°F ambient. Standard unit controls to 30°F ambient.
  2. High Ambient Control: Permits unit operation above 115°F ambient.
- C. Power Supply Connections:
1. Single Point Power Supply: Single point Terminal Block for field connection and interconnecting wiring to the compressors. Separate external protection must be supplied, by others, in the incoming power wiring, which must comply with the National Electric Code and/or local codes.
  2. Single Point Circuit Breaker: Single point Terminal Block with Circuit Breaker and lockable external handle (in compliance with Article 440-14 of N.E.C.) can be supplied to isolate power voltage for servicing. Incoming power wiring must comply with the National Electric Code and/or local codes.
- D. Control Power Transformer: Converts unit power voltage to 120-1-60 (500 VA capacity). Factory-mounting includes primary and secondary wiring between the transformer and the control panel.
- E. Condenser Coil Environmental Protection:
- Environment Guard Premium** – Microchannel condenser coils coated with an electro-deposited and baked flexible epoxy coating that is finished with a polyurethane UV resistant top-coat.
- Environment Guard Basic** – Microchannel condenser coils treated with immersion bath-applied chemical treatment.
- Microchannel condenser shall be provided with a 5-year warranty against corrosion damage.**
- F. Thermal Dispersion Flow Switch (Factory installed and wired in piping extension kit): normally open, 30 Bar pressure rating, stainless steel 316L construction, IP67, -4°F to 158°F ambient rating.
- G. Evaporator options:
1. Provide 1-1/2 inch evaporator insulation in lieu of standard 3/4 inch.

## ***Guide Specifications (Cont'd)***

H. Vibration Isolation (Field installed):

1. Elastomeric Isolators.
2. 1 Inch Deflection Spring Isolators: level adjustable, spring and cage type isolators for mounting under the unit base rails.

### **PART 3 – EXECUTION**

#### **3.01 INSTALLATION**

- A. General: rig and install in full accordance with manufacturer's requirements, project drawings, and contract documents.
- B. Location: locate chiller as indicated on drawings, including cleaning and service maintenance clearance per manufacturer instructions. Adjust and level chiller on support structure.
- C. Components: installing contractor shall provide and install all auxiliary devices and accessories for fully operational chiller.
- D. Electrical: co-ordinate electrical requirements and connections for all power feeds with electrical contractor (Division 16).
- E. Controls: co-ordinate all control requirements and connections with controls contractor.
- F. Finish: installing contractor shall paint damaged and abraded factory finish with touch-up paint matching factory finish.

# NOTES

## SI Metric Conversion

Values provided in this manual are in the English inch-pound (I-P) system.

The following factors can be used to convert from English to the most common SI Metric values.

MEASUREMENT	MULTIPLY THIS ENGLISH VALUE	BY	TO OBTAIN THIS METRIC VALUE
CAPACITY	TONS REFRIGERANT EFFECT (ton)	3.516	KILOWATTS (kW)
POWER	KILOWATTS (kW)	NO CHANGE	KILOWATTS (kW)
	HORSEPOWER (hp)	0.7457	KILOWATTS (kW)
FLOW RATE	GALLONS / MINUTE (gpm)	0.0631	LITERS / SECOND (L/s)
LENGTH	FEET (ft)	304.8	MILLIMETERS (mm)
	INCHES (in)	25.4	MILLIMETERS (mm)
WEIGHT	POUNDS (lb)	0.4536	KILOGRAMS (kg)
VELOCITY	FEET / SECOND (fps)	0.3048	METERS / SECOND (m/s)
PRESSURE DROP	FEET OF WATER (ft)	2.989	KILOPASCALS (kPa)
	POUNDS / SQ. INCH (psi)	6.895	KILOPASCALS (k Pa)

### TEMPERATURE

To convert degrees Fahrenheit (°F) to degrees Celsius (°C), subtract 32° and multiply by 5/9 or 0.5556.

To convert a temperature range (i.e., 10°F or 12°F chilled water range) from Fahrenheit to Celsius, multiply by 5/9 or 0.5556.

### FOULING FACTOR

ENGLISH I-P (ft <sup>2</sup> °F hr/Btu)	EQUIVALENT SI METRIC (m <sup>2</sup> k/kW)
0.0001	0.018
0.00025	0.044
0.0005	0.088
0.00075	0.132

### EFFICIENCY

In the English I-P system, chiller efficiency is measured in kW / ton:

$$\text{kW/ton} = \frac{\text{kW input}}{\text{tons refrigeration effect}}$$

In the SI Metric system, chiller efficiency is measured in Coefficient of Performance (COP).

$$\text{kW/ton} = \frac{\text{kW input}}{\text{kW refrigeration effect}}$$

kW / ton and COP are related as follows:

$$\text{kW/ton} = \frac{3.516}{\text{COP}}$$

$$\text{COP} = \frac{3.516}{\text{kW/ton}}$$

