



Millennium™
ROTARY SCREW LIQUID CHILLERS

RENEWAL PARTS

Supersedes: Nothing

Form 160.47-RP7 (599)

**MODEL YS BA CB S0 THRU YS FA FB S5
(STYLE D)
100 THRU 675 TONS
(315 THRU 2375 KW)**

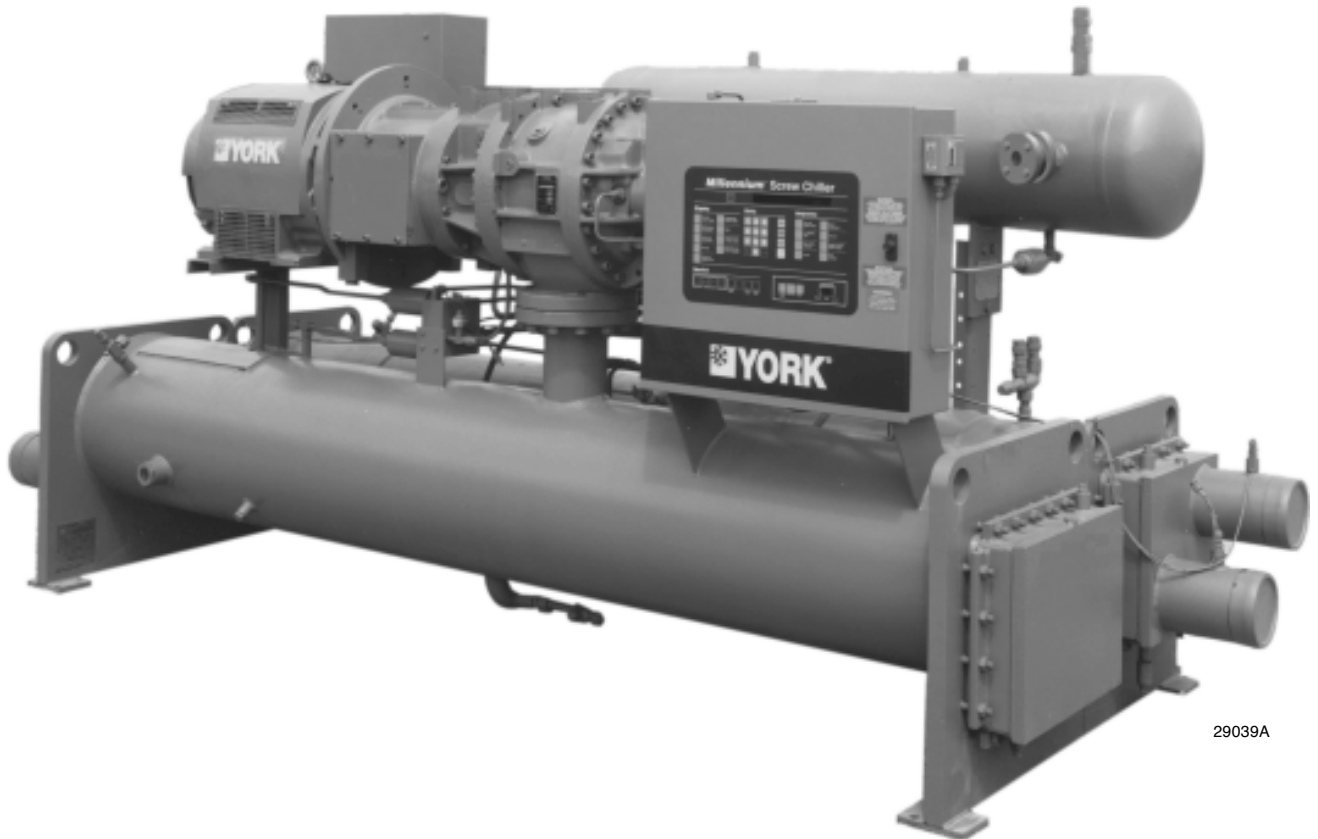

29039A

R-22 and R-134a

TABLE OF CONTENTS

NOMENCLATURE	3
AVAILABLE COMPRESSOR/SHELL/MOTOR COMBINATIONS	3
UNITS COMPONENTS	4
CURRENT TRANSFORMERS KITS	13
OIL SEPARATOR	13
ORIFICE PLATE	13
WATER BOX GASKETS	14
TUBES	15
ISOLATORS	16
MULTIPLE-UNIT SEQUENCE KIT CONTROLS	17
MISCELLANEOUS & ACCESSORIES	18

LIST OF FIGURES

1	UNIT FRONT VIEW	5
2	UNIT REAR VIEW	6
3	UNIT END VIEW	8
4	OIL EDUCTOR SCHEMATIC	10
5	OIL PIPING SCHEMATIC	11
6	CAPACITY CONTROL PIPING SCHEMATIC	12

FREQUENT REPLACEABLE PARTS

ITEM NUMBER	DESCRIPTION	PART NUMBER	QTY
18	TEFLON SEAL WASHER	028-12709-000	6
19*	FILTER - DRIER SUCTION	026-32839-000	2
27*	FILTER - DRIER	026-32841-000	1
37	OIL FILTER ELEMENT	026-32831-000	1
38	O-RING, OIL FILTER	026-32000-000	1

* Each filter/drier Item #19 and #27 requires (2) teflon seal washers Item #18.

NOMENCLATURE

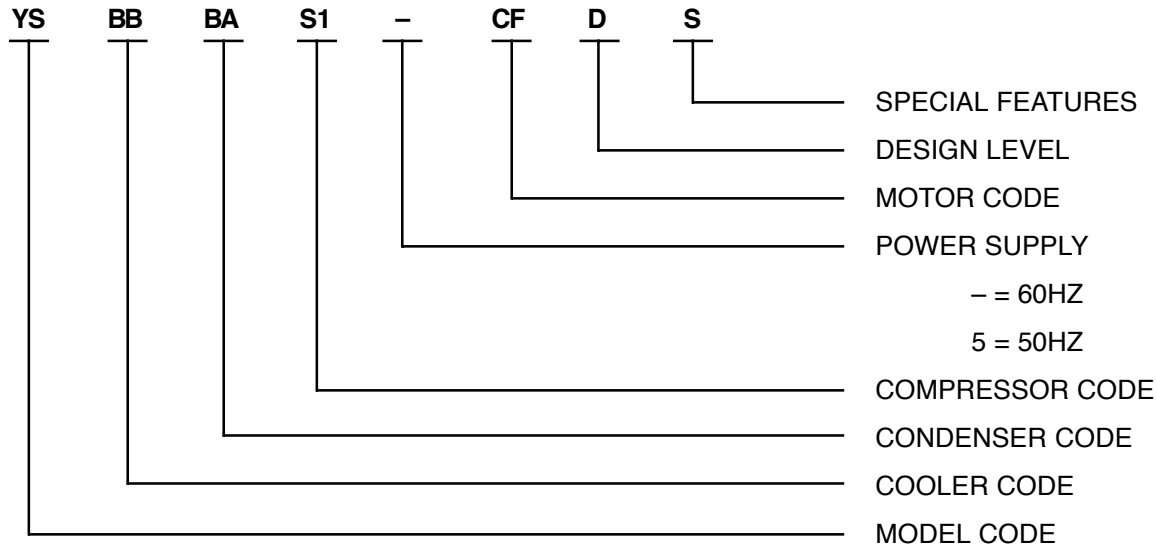

AVAILABLE COMPRESSOR/SHELL/MOTOR COMBINATION

COMPRESSOR CODE	COOLER SHELL	CONDENSER SHELL	MOTOR CODE		
			R-22, 60 HZ	R-134a, 60 HZ	R-22, 50 HZ
S0	BA, BB	BA, BB, CA, CB	CF, CG, CH	CF, CG, CH	5 CC, 5 CD
	CA, CB	BA, BB, CA, CB			
S1	BA, BB	BA, BB, CA, CB	CF, CG, CH, CJ, CK	CF, CG, CH, CJ, CK	5 CC, 5 CD, 5 CE, 5 CF
	CA, CB	BA, BB, CA, CB			
S2	CA, CB	CA, CB, DA, DB	CG, CH, CJ, CK, CL, CM	CF, CG, CH, CJ, CK, CL, CM	5 CD, 5 CE, 5 CF, 5 CG, 5 CH
	DA, DB, DC	CA, CB, DA, DB			
S3	DA, DB, DC	CA, CB, DA, DB	CJ, CK, CL, CM, CN, CP, CR	CG, CH, CJ, CK, CL, CM, CN, CP, CR	5 CF, 5 CG, 5 CH, 5 CI, 5 CJ, 5 CK
S4	EA, EB, EC	EA, EB, FA, FB	CK, CL, CM, CN, CP, CR, CS, CT, CU, CV	CJ, CK, CL, CM, CN, CP, CR, CS, CT, CU, CV	5 CF, 5 CG, 5 CH, 5 CI, 5 CJ, 5 CK, 5 CL, 5 CM, 5 CN, 5 CO
	FA, FB, FC	FA, FB			
S5	FA, FB, FC	FA, FB	CK, CL, CM, CN, CP, CR, CS, CT, CU, CV	CK, CL, CM, CN, CP, CR, CS, CT, CU, CV	

COMPRESSOR CODE	COOLER SHELL	CONDENSER SHELL	MOTOR CODE
S0	BA, BB	BA, BB, CA, CB	5 CC, 5 CD
	CA, CB	BA, BB, CA, CB	
S1	BA, BB	BA, BB, CA, CB	5 CC, 5 CD, 5 CE, 5 CF
	CA, CB	BA, BB, CA, CB	
S2	BA, BB	BA, BB, CA, CB	5 CC, 5 CD, 5 CE, 5 CF, 5 CG, 5 CH
	CA, CB	BA, BB, CA, CB, DA, DB	
	DA, DB, DC	CA, CB, DA, DB	
S3	CA, CB	CA, CB, DA, DB	5 CC, 5 CD, 5 CE, 5 CF, 5 CG, 5 CH, 5 CI, 5 CJ, 5 CK
	DA, DB, DC	CA, CB, DA, DB	
S4	DA, DB, DC	CA, CB, DA, DB	5 CE, 5 CF, 5 CG, 5 CH, 5 CI, 5 CJ, 5 CK, 5 CL, 5 CM, 5 CN, 5 CO
	EA, EB, EC	EA, EB, FA, FB	
	FA, FB, FC	EA, EB, FA, FB	
S5	EA, EB, EC	EA, EB, FA, FB	5 CF, 5 CG, 5 CH, 5 CI, 5 CJ, 5 CK, 5 CL, 5 CM, 5 CN, 5 CO
	FA, FB, FC	EA, EB, FA, FB	

UNIT COMPONENTS

ITEM NUMBER	DESCRIPTION	PART NUMBER	QUANTITY PER UNIT	REFERENCE FIGURE
1	Valve, Angle Stop - Rotalock®	022-09573-000	3	1, 2
2	Cap, Flare	023-00984-000	3	1, 2
3	Gasket, Seal	028-04836-000	3	1, 2
4	Shim, Motor Mounting	066-87439-000	8	1
5		066-92388-000	4	
6		066-92389-000	4	
7	Bottle, Oil	028-10579-000	1	1
8	Rupture Disk, 2"		1	1, 3
	S0-S1 R-22	026-36503-001		
	S0-S1 R-134a	026-36503-001		
	S2-S3 R-22	026-36503-002		
	S2-S3 R134a	026-36503-001		
	S4 R-22	026-36503-003		
	S4 R-134a	026-36503-004		
	S5 R-22	026-36503-002		
	S5 R-134a	026-36503-003		
8A	Rupture Disk 2" S4 & S5 Compressors	026-36503-004	1	1
9	Safety Head, 2"	026-32293-000	1 (S0-S3) 2 (S4-S5)	1, 3
10	Gasket, Round, Rupture Disk	028-10386-028	2 (S0-S3) 5 (S4-S5)	1, 3
11	Hi-Pressure Cutout - 270 PSIG	025-30970-000	1	1, 2
12	Valve, Relief			
	S0, S1 Compressors - 3/4"	022-09501-000	4	1, 2, 3
	S2 Compressors - 3/4" (B & C Coolers)	022-09501-000	5	
	S2, S3 Compressors - 3/4" (D Cooler)	022-09501-000	4	
	S4, S5 Compressors - 1"	022-09505-000	5	
13	Seal, "O"-Ring	028-12961-005	6	1, 2, 3
14	Valve, Three-Way Stop	022-09515-000	1 (S0-S1) 2 (S2-S5)	1, 2, 3
14a	Connector, Union	023-17643-000	1	1, 3
15	Well, Sensor (Clr and Cond Water)	026-32328-000	4	1, 2
16	Sensor, Temp. (Clr and Cond Water) - 300 ohm	025-29964-000	4	1, 2
17	Valve, Angle Stop - Rotalock®	022-09756-000	1 (S0-S1)	1, 4
18	Seal, Teflon Fiber	028-12709-000	11	1, 2, 3, 4
19	Filter, Suction *	026-32839-000	2	1
20	Eductor, Oil		1	1
	S0, S1 Compressors - R-22	026-35381-000		
	R-134a	026-35383-000		
	S2, S3 Compressors - R-22	026-35381-000		
	R-134a	026-35383-000		
	S4, S5 Compressors - R-22	026-35382-000		
	R-134a	026-35384-000		
21	Valve, Angle Stop - Transducer Isolation	022-09577-000	5	1, 3, 5
22	Gasket, Compressor Suction		1	1
	S0, S1 Compressors - 9-7/8" OD, 6-5/8" ID	028-13574-000		
	S2, S3 Compressors - 12-1/8" OD, 8-5/8" ID	028-13575-000		
	S4, S5 Compressors - 14-1/4" OD, 10-3/4" ID	028-13576-000		
23	Sensor, Temperature - 50,000 Ohms	025-33288-000	2	1, 3, 5
24	Seal, "O"-Ring	028-12961-004	11	1, 3, 4, 5
25	Valve, Bleed	022-09783-000	2	1, 2
26	Seal, "O"-Ring	028-12961-001	11	1, 2

* Special Primore Rotalock Fitting - Requires (2) teflon seal washers P/N 028-12709-000

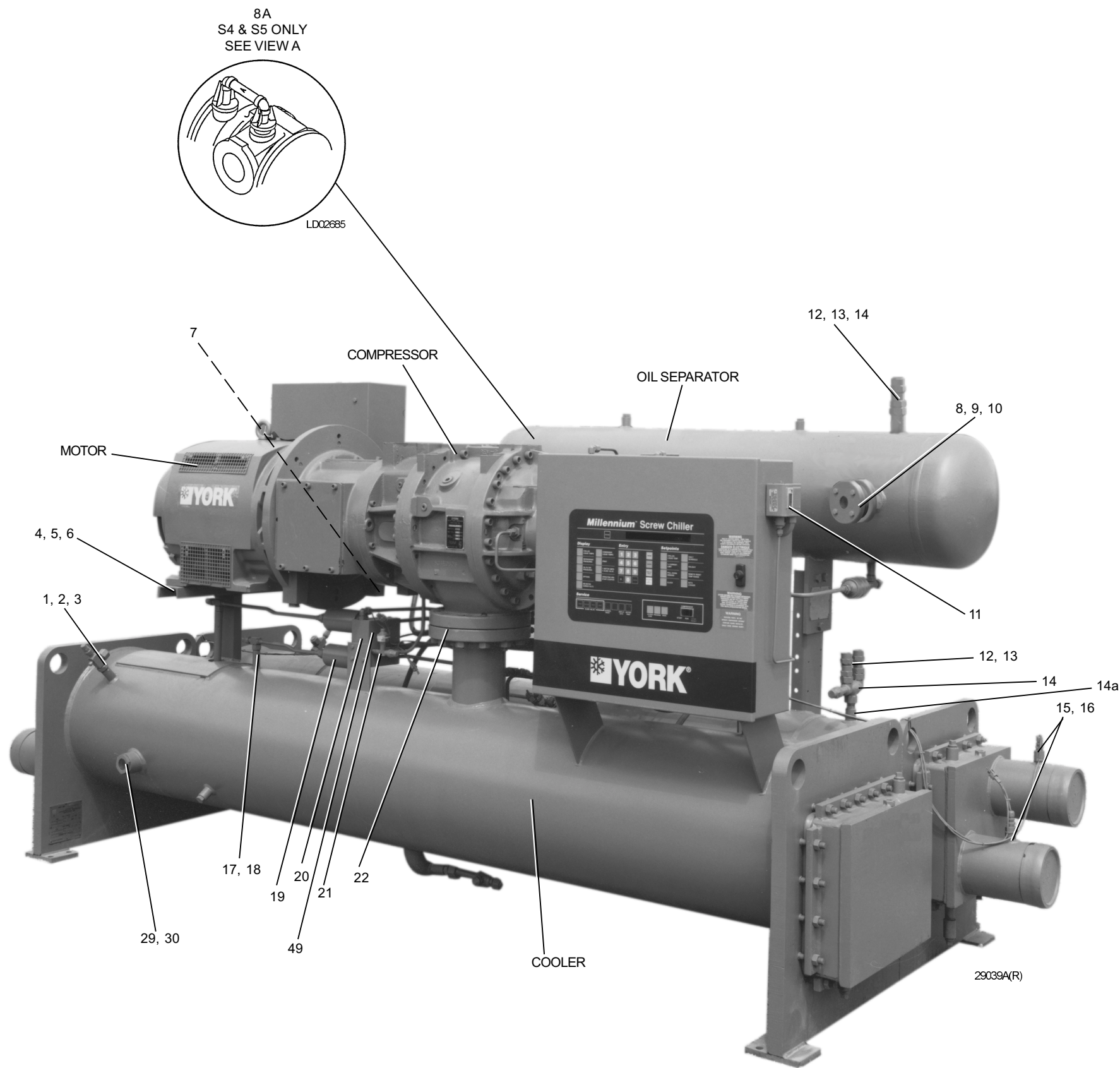
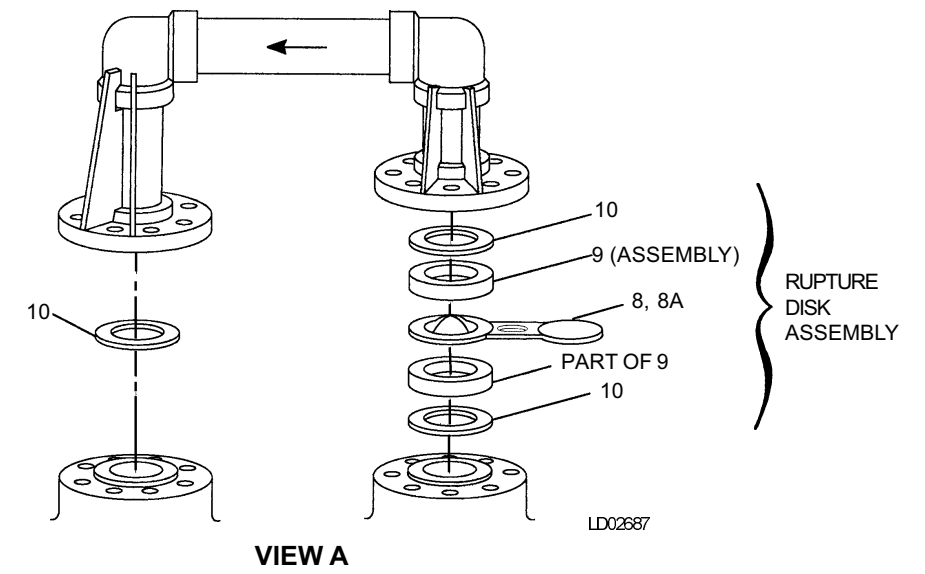
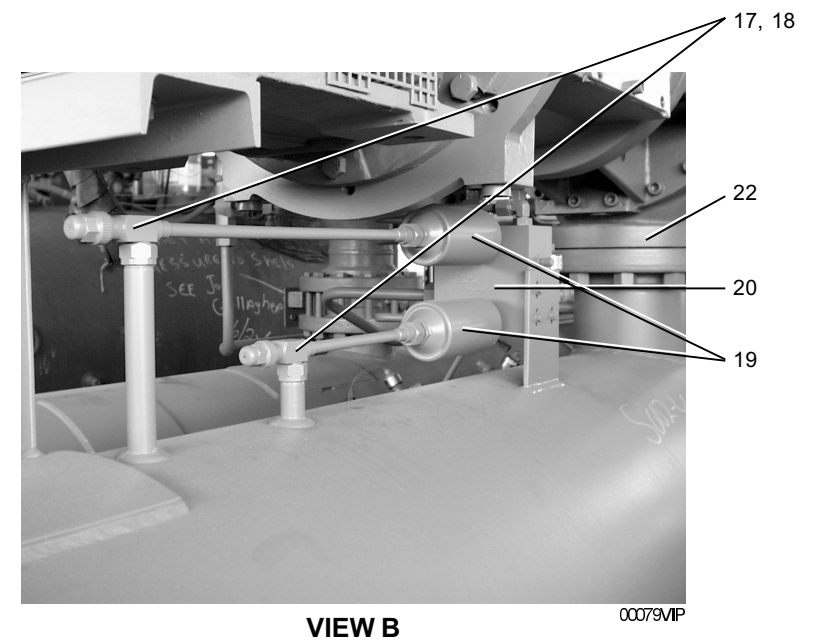

FIG. 1 - UNIT FRONT VIEW



VIEW A



VIEW B

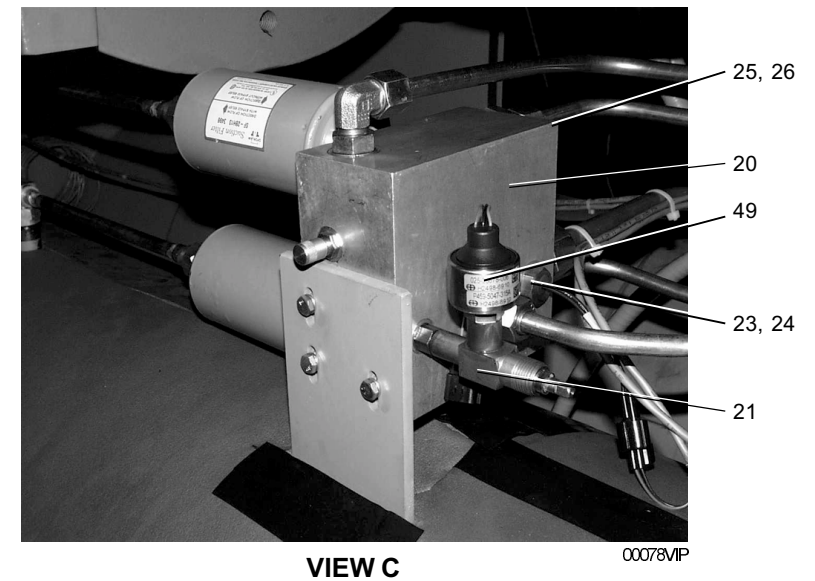

VIEW C

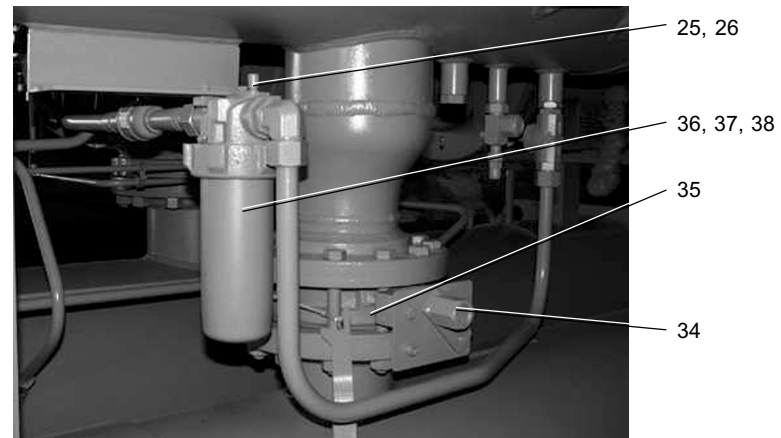

VIEW A

00080VP

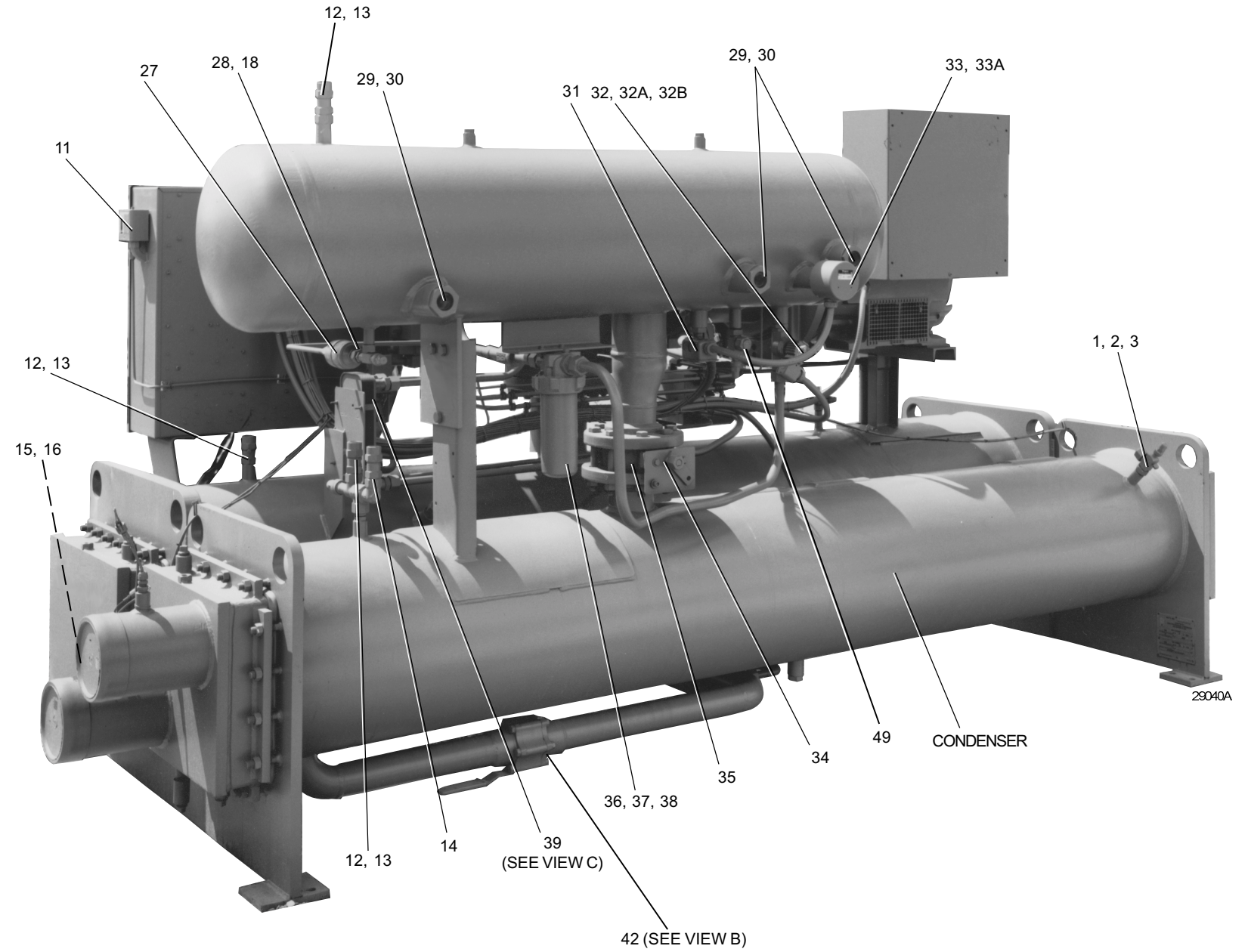
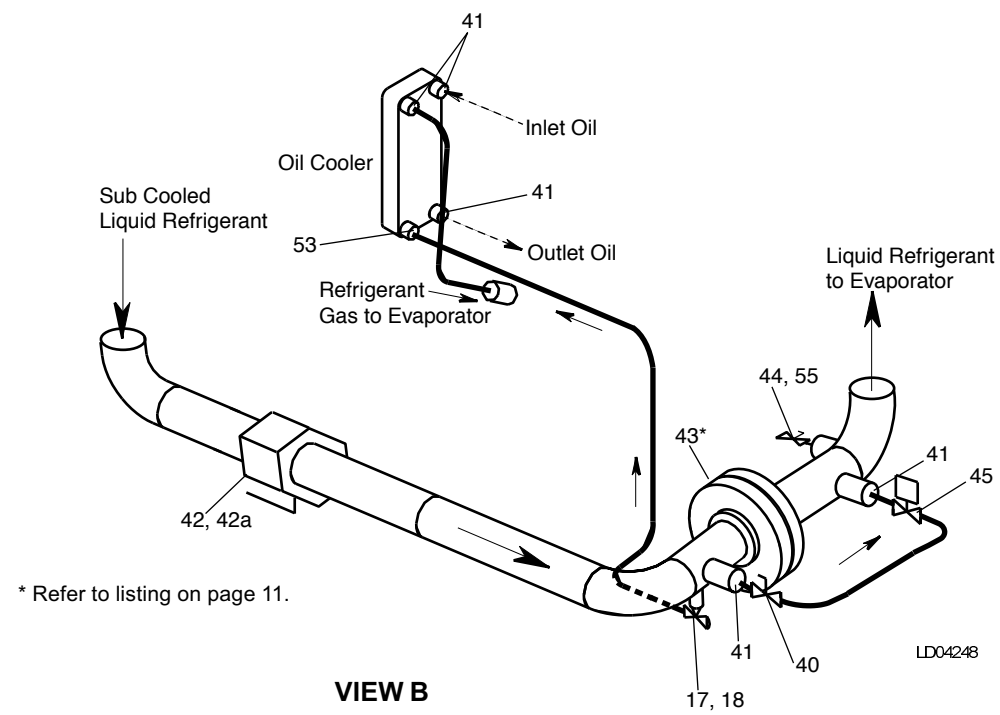
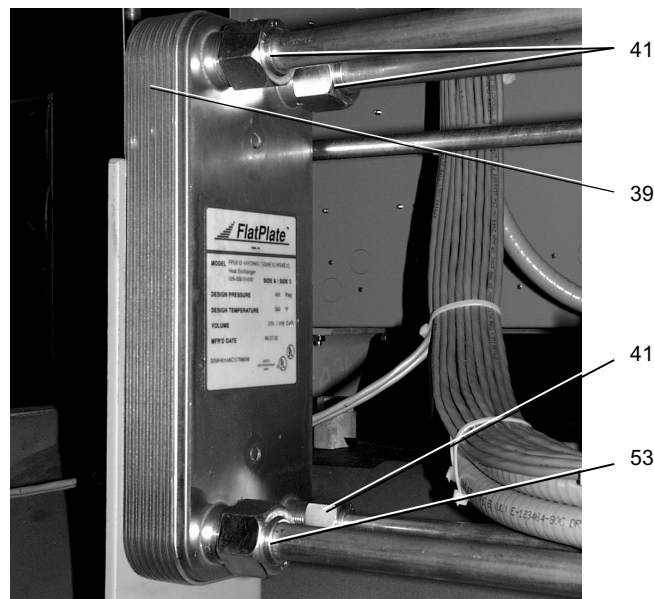

FIG. 2 - UNIT REAR VIEW



* Refer to listing on page 11.

VIEW B



VIEW C

00082VIP

UNIT COMPONENTS

ITEM NUMBER	DESCRIPTION	PART NUMBER	QUANTITY PER UNIT	REFERENCE FIGURE
27	Filter Drier *	026-32841-000	1	2, 3, 4
28	Valve, Angle Stop	022-09792-000	1	2, 3
29	Sight Glass	023-17197-000	4	2
30	Seal, "O"-Ring	028-12961-009	4	1, 2
31	Float Switch, Oil Level	024-30901-000	1	1, 2
32	Valve, Solenoid			
	S0, S1 Compressors	025-33702-000	1	2, 5
	S2, S3 Compressors	025-33702-000	1	
	S4, S5 Compressors	Not Required	—	
33	Oil Heater (1HTR)	025-33703-000	1	2
33a	Seal "O"-Ring	028-12961-017	1	2
34	Valve, Butterfly		1	2
	S0, S1 Compressors	022-08874-000		
	S2, S3 Compressors	022-08875-000		
	S4, S5 Compressors	022-08876-000		
35	Gasket, Butterfly Valve		2	2
	S0, S1 Compressors - 7-1/8" OD, 4-1/2" ID	028-13573-000		
	S2, S3 Compressors - 9-7/8" OD, 6-5/8" ID	028-13574-000		
	S4, S5 Compressors - 12-1/8" OD, 8-5/8" ID	028-13575-000		
36	Filter, Oil (Complete)	026-35621-000	1	2, 5
	Includes Items 37, 38		2 (Optional)	
37	Element, Oil Filter - 3 Micron	026-32831-000	1	2
38	Replacement "O"-Rings Kit, Oil Filter	026-32000-000	1	2
39	Cooler, Oil		1	2, 3, 5
	S0, S1 Compressors	026-36536-000		
	S2, S3 Compressors	026-36536-000		
	S4, S5 Compressors	026-36552-000		
40	Valve, Ball	022-09580-000	1	2
41	"O"-Ring Face Seal	028-12961-015	8	2, 5
42	Valve, Angle	022-09756-000	1	2
42a	Teflon Fiber Seal Washer	028-21709-000	1	2
43	Gasket, Round, Orifice Plate	028-13572-000	2	2, 3
44	Valve, Ball	022-09757-000	1	2
45	Valve, Solenoid	025-33738-000	1	2
46	Valve, 4-Way Solenoid	025-30464-000	1	3, 7
46a	Manifold Solenoid Sub-Plate	029-22732-000	1	3, 7
47	Valve, Angle Stop	022-09199-000	1	3, 4

* Special Primore Rotolock Fitting - Requires (2) teflon seal washers P/N 028-12709-000

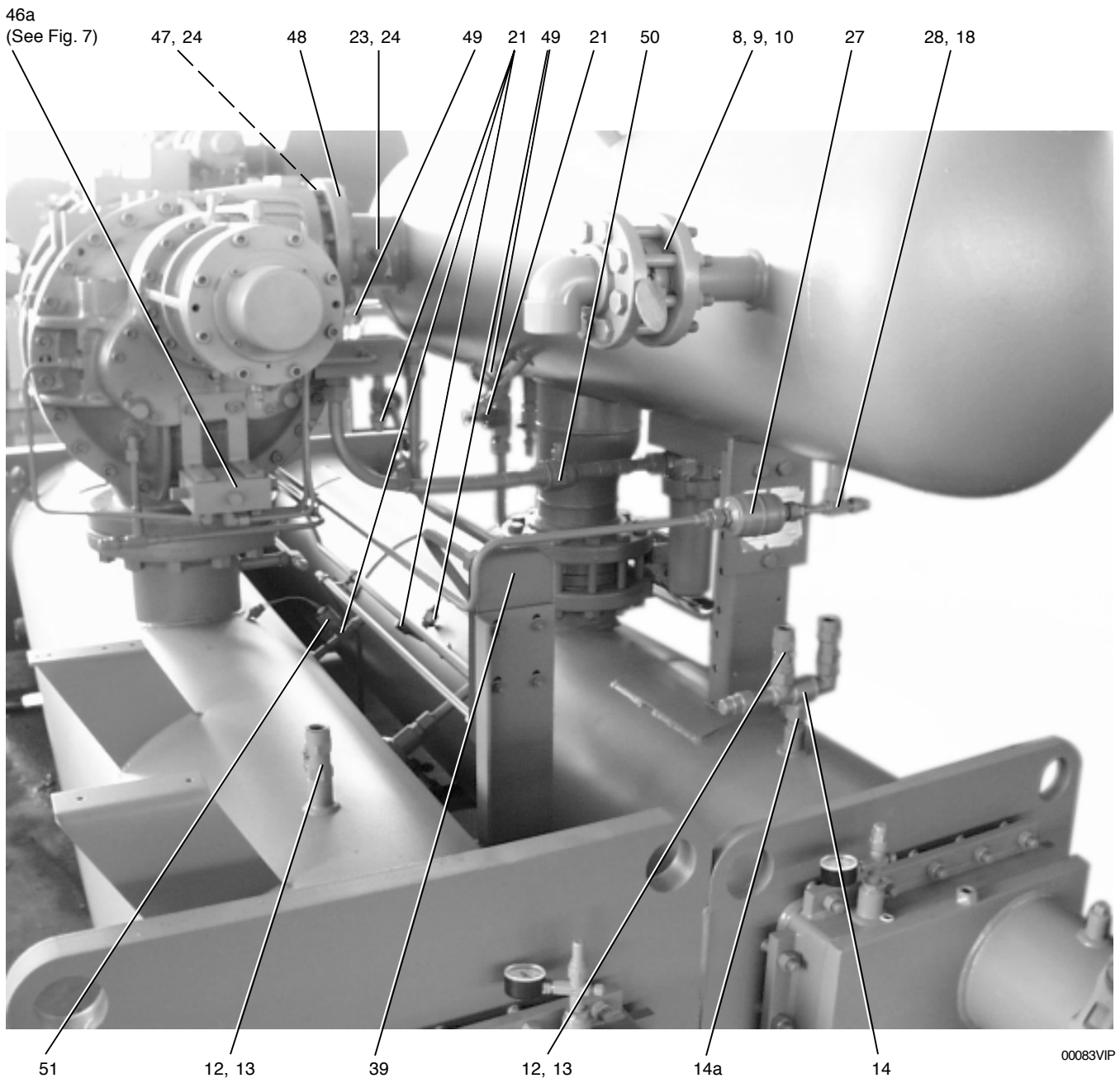

FIG. 3 – UNIT END VIEW

UNIT COMPONENTS

ITEM NUMBER	DESCRIPTION	PART NUMBER	QUANTITY PER UNIT	REFERENCE FIGURE
48	Gasket, Compressor Discharge		1	3
	S0, S1 Compressors - 7-1/8" OD, 4-1/2" ID	028-13573-000		
	S2, S3 Compressors - 9-7/8" OD, 6-5/8" ID	028-13574-000		
	S4, S5 Compressors - 12-1/8" OD, 8-5/8" ID	028-13575-000		
49*	Transducer, Condenser – Oil, Filter Oil, Seal Oil	025-28678-006	4	1, 2, 3, 5
50	Valve, Ball	022-09797-000	1 (Single Filter) (S0-S3) 4 (Dual Filter) (S0-S3) 2 (Single Filter) (S4-S5) 4 (Dual Filter) (S4-S5)	3, 5
51*	Transducer, Evaporator		1	3
	R22, Water	025-28678-007		
	R22, Brine	025-28678-009		
	R134a, Water and Brine	025-28678-008		
52	Suppressor	031-00808-000	4 4 3	—
	S0, S1 Compressors ¹			
	S2, S3 Compressors ¹			
	S4, S5 Compressors ²			
53	Seal, "O"-Ring	028-12961-013	7	4
54	Seal, "O"-Ring	028-12961-016	4	5
55	Seal, "O"-Ring	028-12961-006	4	5
56	Seal, "O"-Ring	028-12961-008	6	5
57	Seal, "O"-Ring	028-12961-002	5	5
58	Seal, "O"-Ring	028-12961-003	8	5
59	Seal, "O"-Ring	028-12961-012	8	6

* Item 49 and 51 are furnished with O-Ring, p/n 028-129610-002.

1. Used in Oil Line Solenoid Valve (1 SOL), Refrigerant Level Solenoid Valve (2 SOL) and Slide Valve Solenoid (2 Req'd).
2. Used in Refrigerant Level Solenoid Valve (2 SOL) and Slide Valve Solenoid (2 Req'd).

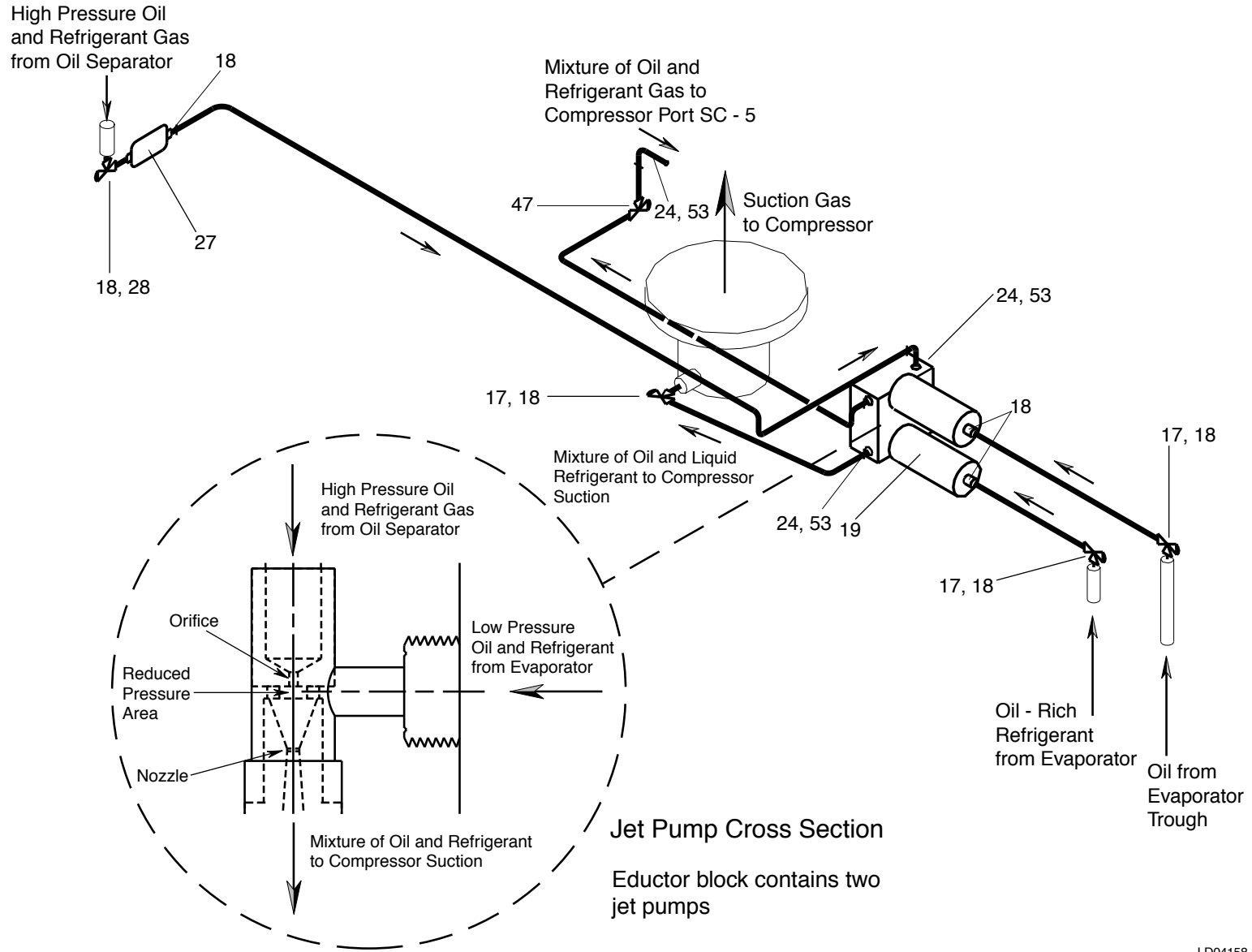
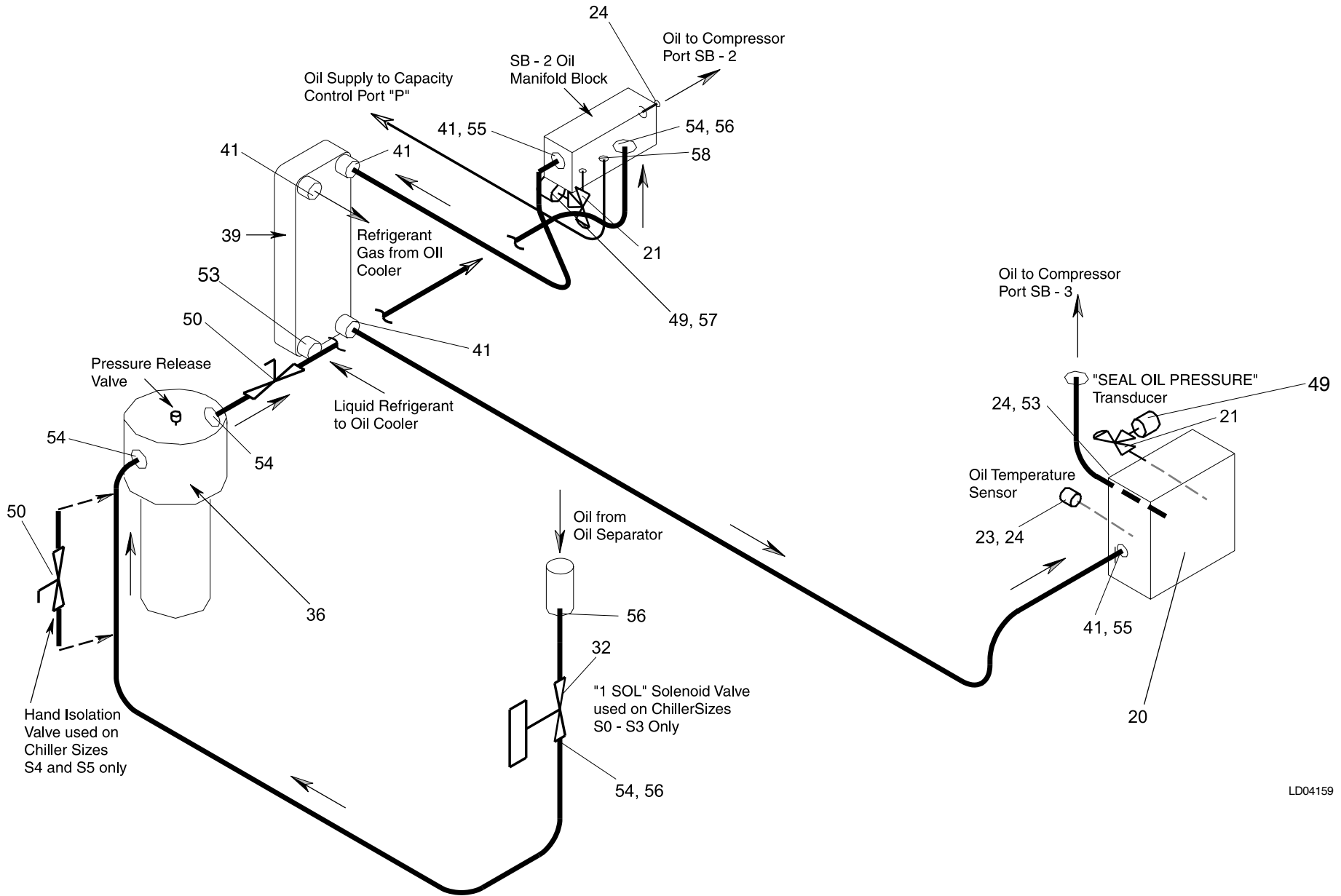
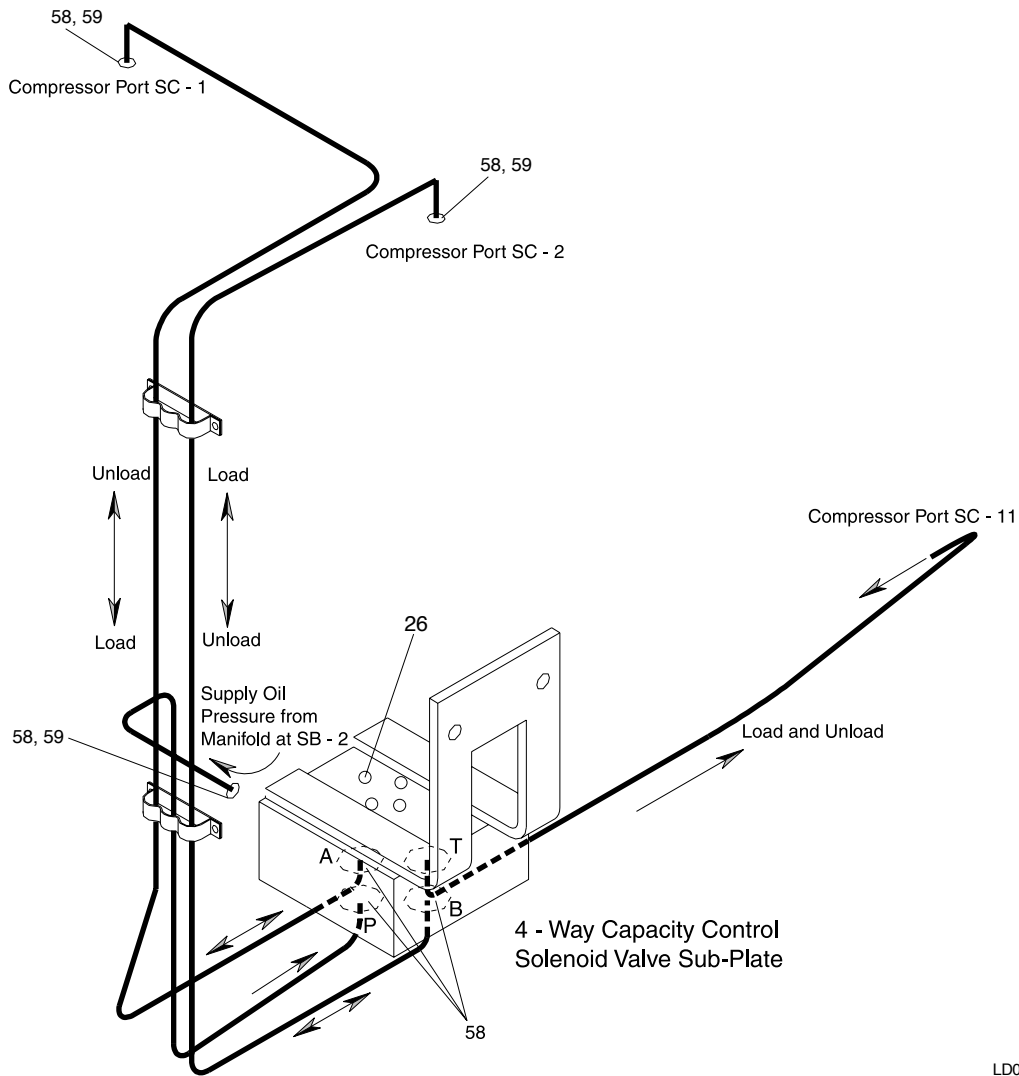

FIG. 4 – OIL EDUCTOR SCHEMATIC



LD04159

FIG. 5 – OIL PIPING SCHEMATIC



LD04160

FIG. 6 – CAPACITY CONTROL PIPING SCHEMATIC

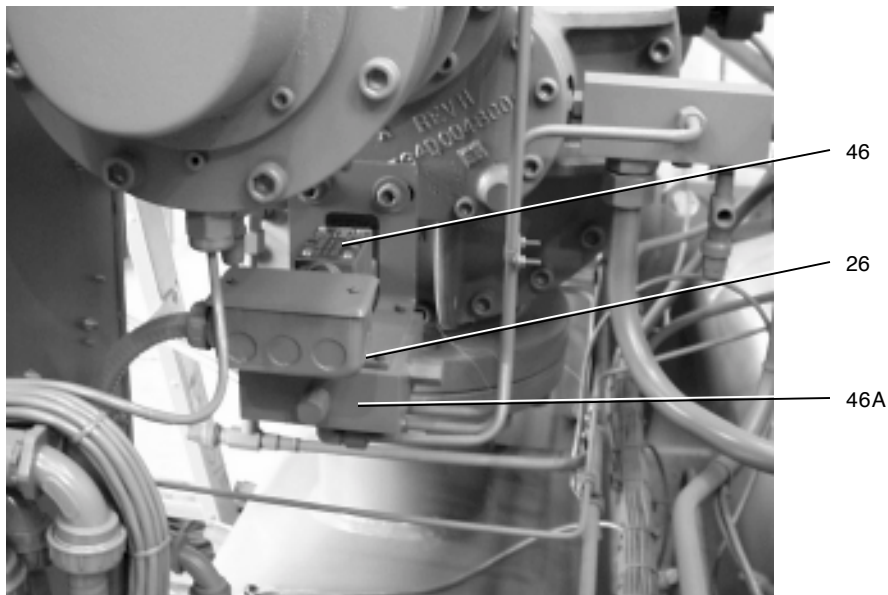

00086VIP

FIG. 7 – 4-WAY SOLENOID VALVE

CURRENT TRANSFORMER KITS

FIELD INSTALLED ELECTRO-MECHANICAL STARTERS ONLY

MOTOR VOLTAGE	FLA	"CT" RATIO	PART NUMBER
			USE WITH FACTORY-MOUNTED MOTORS ONLY
200/600	65-111	200:1	366-82718-701
	112-224	350:1	366-82718-702
	225-829	700:1	366-82718-703
	830-1790	1400:1	366-82718-704
2300/4160	11-18	200:1	366-82718-705
	19-37	200:1	366-82718-705
	38-123	200:1	366-82718-705
	124-264	350:1	366-82718-706

TRANSFORMER ONLY

CT RATIO	PART NUMBER
200:1	025-21173-001
350:1	025-21173-002
700:1	025-21173-003
1400:1	025-21173-004

OIL SEPARATOR

COMPRESSOR SIZE	PART NUMBER
S0	375-22455-000
S1	375-22455-000
S2	375-22456-000
S3	375-22456-000
S4	375-22457-000
S5	375-22457-000

ORIFICE PLATE

CODE	PART NUMBER	CODE	PART NUMBER
C	075-00748-001	N	075-00748-011
D	075-00748-002	P	075-00748-012
E	075-00748-003	Q	075-00748-013
F	075-00748-004	R	075-00748-014
G	075-00748-005	S	075-00748-015
H	075-00748-006	T	075-00748-016
J	075-00748-007	U	075-00748-017
K	075-00748-008	V	075-00748-018
L	075-00748-009	W	075-00748-019
M	075-00748-010		

WATER BOX GASKETS

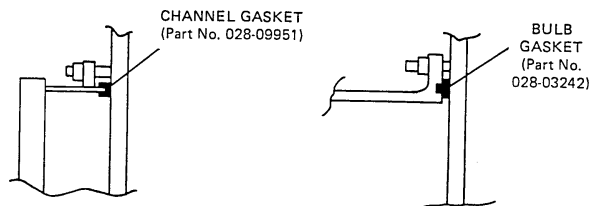

LD02690

COOLER WITH STANDARD COMPACT WATER BOXES 150 PSI

SHELL CODE	1 PASS		2 PASS		3 PASS	
	GASKET PART NO.	FEET REQ'D	GASKET PART NO.	FEET REQ'D	GASKET PART NO.	FEET REQ'D
BA,BB	028-09951	12.0	028-09951	14.0	028-09951	14.0
CA,CB	028-09951	12.0	028-09951	14.0	028-09951	15.0
DA,DB,DC	028-09951	17.0	028-09951	20.0	028-09951	22.0
EA,EB,EC	028-09951	18.0	028-09951	21.0	028-09951	23.0
FA,FB,FC	028-03242	21.0	028-03242	21.0	028-03242	21.0
			028-09951	4.0	028-09951	3.5

COOLER WITH MARINE WATER BOXES 150 PSI

SHELL CODE	1 PASS		2 PASS		3 PASS	
	GASKET PART NO.	FEET REQ'D	GASKET PART NO.	FEET REQ'D	GASKET PART NO.	FEET REQ'D
BA,BB	028-03242	13.0	028-03242	13.0	028-03242	13.0
			028-09951	4.0	028-09951	3.0
CA,CB	028-03242	14.0	028-03242	14.0	028-03242	14.0
			028-09951	5.0	028-09951	4.0
DA,DB,DC	028-03242	18.0	028-03242	18.0	028-03242	18.0
			028-09951	6.0	028-09951	5.0
EA,EB,EC	028-03242	36.0	028-03242	24.0	028-03242	36.0
			028-09951	6.0	028-09951	10.0
FA,FB,FC	028-03242	44.0	028-03242	33.0	028-03242	44.0
			028-09951	13.0	028-09951	13.0

COOLER WITH MARINE WATER BOXES 300 PSI

SHELL CODE	1 PASS		2 PASS		3 PASS	
	GASKET PART NO.	FEET REQ'D	GASKET PART NO.	FEET REQ'D	GASKET PART NO.	FEET REQ'D
BA,BB	028-03242	13.0	028-03242	13.0	028-03242	13.0
			028-09951	4.5	028-09951	4.5
CA,CB	028-03242	13.0	028-03242	13.0	028-03242	13.0
			028-09951	5.0	028-09951	4.0
DA,DB,DC	028-03242	16.5	028-03242	16.5	028-03242	16.5
			028-09951	6.0	028-09951	5.5
EA,EB,EC	028-03242	18.0	028-03242	18.0	028-03242	18.0
			028-09951	6.5	028-09951	6.0
FA,FB,FC	028-03242	21.0	028-03242	21.0	028-03242	21.0
			028-09951	7.5	028-09951	7.0

WATER BOX GASKETS

CONDENSER WITH STANDARD COMPACT WATER BOXES 150 PSI

SHELL CODE	1 PASS		2 PASS	
	GASKET PART NO.	FT. REQ'D	GASKET PART NO.	FT. REQ'D
BA,BB	028-09951	11.0	028-09951	12.0
CA,CB	028-09951	12.0	028-09951	14.0
DA,DB	028-09951	16.0	028-09951	18.0
EA,EB	028-09951	16.0	028-09951	18.0
FA,FB	028-03242	20.0	028-03242 028-09951	20.0 3.0

CONDENSER WITH MARINE WATER BOXES 150 PSI

SHELL CODE	1 PASS		2 PASS	
	GASKET PART NO.	FT. REQ'D	GASKET PART NO.	FT. REQ'D
BA,BB	028-03242	11.0	028-03242 028-09951	11.0 3.0
CA,CB	028-03242	14.0	028-03242 028-09951	14.0 3.0
DA,DB	028-03242	17.0	028-03242 028-09951	17.0 4.0
EA,EB	028-03242	17.0	028-03242 028-09951	17.0 4.0
FA,FB	028-03242	21.0	028-03242 028-09951	21.0 6.0

CONDENSER WITH MARINE WATER BOXES 300 PSI

SHELL CODE	1 PASS		2 PASS	
	GASKET PART NO.	FT. REQ'D	GASKET PART NO.	FT. REQ'D
BA,BB	028-03242	10.5	028-03242 028-09951	10.5 3.5
CA,CB	028-03242	11.5	028-03242 028-09951	11.5 4.0
DA,DB	028-03242	14.0	028-03242 028-09951	14.0 4.5
EA,EB	028-03242	14.0	028-03242 028-09951	14.0 4.5
FA,FB	028-03242	18.0	028-03242 028-09951	18.0 6.0

TUBES

COOLER TUBES

SHELL CODE	SHELL ID	TUBE QUANTITY
PART NUMBER 007-07872-000		
BA	19	100
BB	19	134
CA	23	174
CB	23	228
DA	29	216
DB	29	307
DC	29	410
PART NUMBER 007-07879-000		
EA	31	217
EB	31	308
EC	31	410
FA	38	410
FB	38	547
FC	38	728

CONDENSER TUBES

SHELL CODE	SHELL ID	TUBE QUANTITY
PART NUMBER 007-08409-000		
BA	17-1/4	133
BB	17-1/4	169
CA	20-1/2	226
CB	20-1/2	292
DA	25	404
DB	25	528
PART NUMBER 007-08408-000		
EA	25	408
EB	25	532
FA	32-1/2	670
FB	32-1/2	902

NEOPRENE VIBRATION ISOLATORS

SYSTEM OPERATING WEIGHT		PART NUMBER Includes Quantity of 4 Pads	PAD SIZE
KILOGRAMS	POUNDS		
Up to 7423	Up to 16365	028-10578-000	4-1/2" x 4-1/2"
7424 to 13079	16366 to 28835	028-10518-000	4-1/2" x 6"
13080 to 24281	28836 to 53530	028-10519-000	6" x 6"

SPRING ISOLATORS (4 Per Unit) – ENGLISH

COMPRESSOR SIZE	SYSTEM OPERATING WEIGHT (Lbs.)	PART NO.
S0, S1, S2, S3	UP to 6,865	029-18479-001
	6,866 to 9,818	029-18479-002
	9,819 to 12,182	029-18479-003
	12,183 to 15,272	029-18479-004
	15,273 to 18,272	029-18480-001
	18,273 to 22,909	029-18480-002
S4, S5	UP to 22,909	029-18480-002
	22,910 to 26,044	029-18480-003
	26,045 to 32,101	029-18480-004

SPRING ISOLATORS (4 Per Unit) – SI

COMPRESSOR SIZE	SYSTEM OPERATING WEIGHT (mm)	PART NO.
S0, S1, S2, S3	UP to 3,114	029-18479-001
	3,115 to 4,453	029-18479-002
	4,454 to 5,525	029-18479-003
	5,526 to 6,927	029-18479-004
	6,928 to 8,288	029-18480-001
	8,289 to 10,392	029-18480-002
S4, S5	UP to 10,392	029-18480-002
	10,392 to 11,813	029-18480-003
	11,814 to 14,561	029-18480-004

MULTIPLE UNIT SEQUENCE KIT CONTROLS STYLES C & D UNITS

TWO UNITS

ITEM	DESCRIPTION	QUANTITY	PART NUMBER
1 ¹	Controller, RWT	1	025-15154-000
2	Relay, Time Delay	1	024-13711-000
3	Switch, Toggle	1	024-14057-000

¹ Not Shown. Remote Mounted.

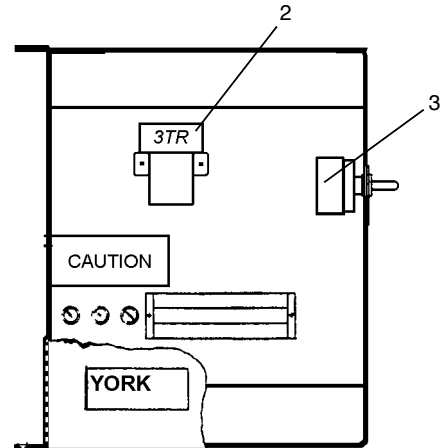

LD03251

THREE UNITS

ITEM	DESCRIPTION	QUANTITY	PART NUMBER
1	Controller, RWT	1	025-10215-000
2	Relay, Time Delay	2	024-13711-000
3	Relay, Control	3	024-27246-000
4	Relay, Control	2	024-14519-000
5	Switch, Toggle	1	024-11736-000
6	Switch, Toggle	1	024-17026-000

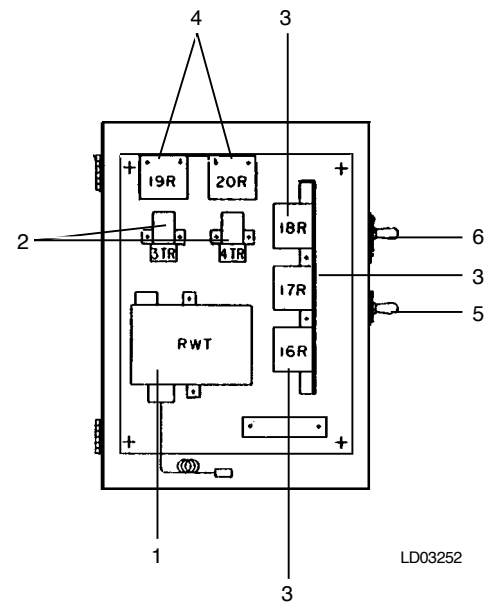

LD03252

FOUR UNITS

ITEM	DESCRIPTION	QUANTITY	PART NUMBER
1	Controller, RWT	1	025-10214-000
2	Relay, Time Delay	3	024-13711-000
3	Relay, Control	3	024-27246-000
4	Relay, Control	8	024-14519-000
5	Switch, Toggle	1	024-11736-000
6	Switch, Rotary	1	024-20494-000

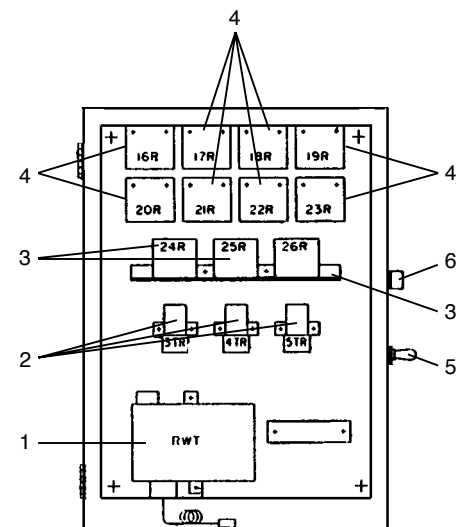

LD03253

MISCELLANEOUS AND ACCESSORIES

COMPOUND

DESCRIPTION	PART NUMBER	QUANTITY
Compound, Heat Conductive (For Thermometer Wells)	013-00898-000	4 Oz. Can

TOUCH-UP PAINTS – SPRAY CANS

DESCRIPTION	PART NUMBER
Caribbean Blue Enamel	013-01835-000
Black (Control Center)	Purchase Locally

TEMPERATURE RECORDER

DESCRIPTION		PART NUMBER
HZ	NUMBER OF PENS	
60	1	025-09658-000
	2	025-09823-000
50	1	025-12650-000
	2	025-12330-000

FLOW SWITCH CONTROL

DESCRIPTION	PART NUMBER
150 DWP	024-26116-000
300 DWP	024-12144-000

DIFFERENTIAL PRESSURE CONTROL

DESCRIPTION	PART NUMBER
Control, Differential Pressure*	025-30919-000

*300 Psi Maximum Working Pressure

YORK OIL	PART NUMBER (5 Gallon Container)	OIL TYPE
YORK "C"	011-00312-000	MINERAL
YORK "P"	011-00589-000	POE
YORK "H"	011-00549-000	POE

NOTES



Proud Sponsor
of the 2000
U.S. Olympic Team

36USC380