 <b>PRODUCT DRAWING</b>	Supersedes: 160.47-PW4 (798) <span style="float: right;">FORM 160.47-PW4 (1098)</span> <b>WIRING DIAGRAM – FIELD CONNECTIONS</b> <b>MILLENNIUM YS (STYLE C &amp; D) ROTARY SCREW CHILLER</b> <b>MICROCOMPUTER CONTROL CENTER</b> <b>WITH YORK SOLID STATE STARTER</b>
YORK INTERNATIONAL CORPORATION P.O. Box 1592, YORK, PA 17405	
CONTRACTOR _____ ORDER NO. _____ YORK CONTRACT NO. _____ YORK ORDER NO. _____	PURCHASER _____ JOB NAME _____ LOCATION _____ ENGINEER _____
<input type="checkbox"/> REFERENCE    DATE _____	<input type="checkbox"/> APPROVAL    DATE _____
<input type="checkbox"/> CONSTRUCTION    DATE _____	

**JOB DATA:**

CHILLER MODEL NO. YS \_\_\_\_\_ NUMBER OF UNITS \_\_\_\_\_  
 SOLID STATE STARTER, MODEL NO. SSS- \_\_\_\_\_ L \_\_\_\_\_  
 MOTOR/STARTER POWER \_\_\_\_\_ VOLTS, 3-PHASE, \_\_\_\_\_ HERTZ  
 OPTIONAL FACTORY INSTALLED DISCONNECT SWITCH \_\_\_\_\_ AMPS

**NOTES:**

1. All field wiring shall be in accordance with the current edition of the National Electrical Code (N.E.C.) as well as all other applicable codes and specifications.
2. Solid State Starter shall be grounded in accordance with the N.E.C. (paragraph 250-91 (b)) for equipment grounding. Where a separate grounding conductor is used, it must be a copper conductor only and sized per the N.E.C. (Table 250-95). See Note 8 for grounding lug wire range.
3. Wiring, electrical conduit, junction boxes, fused disconnect switches (FDS), or circuit breakers, starters (M), push-button stations (PB), manual-off-automatic switch (S), flow switch (FLS), and control relays furnished by others unless otherwise specified.
4. Items marked with an \* are furnished by York International Corporation.
5. Items marked with an \*\* are available from York International Corporation at additional cost.
6. Control power supply 115V – 50/60 Hz, 1.5 KVA capacity for control center only, is supplied by a control power transformer (5T) mounted on the side of the Solid State Starter as shown. It is factory wired.
7. Multiple conduits must contain an equal number of wires from each phase in each conduit to prevent overheating. Use copper conductors only; DO NOT USE aluminum conductors. See Note 8 for factory furnished starter terminal lugs.

8. The following terminal lugs are factory furnished for field wiring connections when a factory-installed disconnect switch is not supplied. All lugs are rated AL9CU.

Starter Model No. w/o Disconnect Option	Line Side Lugs		Grounding Lug Wire Range, Quantity
	Quan. Per Terminal	Wire Range	
SSS 7L	1	#2 - 500MCM	#6 AWG to 350MCM, one bbl.
SSS 14L	2	#2 - 500MCM	
SSS 26L	3	#2 - 600MCM	#6 AWG - 250MCM, four bbl.
SSS 33L	4		

The following terminal lugs are factory furnished for field wiring connections when a factory-installed disconnect switch is supplied.

Starter Model No. & Avail. Disconnect Amp Rating (See Note 17a)	Line Side Lugs			Grounding Lug Wire Range, Quantity (AL9CU)
	Quan. Per Terminal	Wire Range	Lug Rating	
SSS 7L, 250A	1	#4 - 350MCM	AL7CU	#6 AWG to 350MCM, one bbl.
SSS 7L, 400A	2	3/0 - 250MCM	AL9CU	
SSS 14L, 600A	2	250 - 500MCM	AL9CU	
SSS 26L, 1000A	4	1/0 - 350MCM	AL7CU	#6 AWG to 250MCM, four bbl.

9. Condenser water pump motor starter (3M) holding coil to be furnished for 115V – 50/60 Hz. The power requirements for the water pump starter (3M) must be a max. of 1 Amp holding and 10 Amps inrush. If power requirements exceed this value, furnish coil for line voltage, and control relay with 115V coil.
10. Units shipped knocked down require field connection of harnesses to control panel, power wiring between compressor motor and starter and SSS cool-

ing pump to solid state starter. These harnesses and power wiring are furnished by York International Corporation for field assembly and consist of proper lengths of flexible conduit with necessary connectors, and contain the wires (shown in Note 13) properly terminated and marked.

11. Wire #14 AWG copper for one way distance of less than 175 feet. Wire #12 AWG copper for one way distance of more than 175 feet, but less than 300 feet.
12. Wiring diagram for YORK Micro Computer Control Center, Style C, Form 160.47-PW2; Style D, Form 160.47-PW12. Field wiring modifications per Form 160.47-PW5. Wiring diagram for YORK Solid State Starter Form 160.47-PW6.
13. The following interconnecting wires are factory supplied when a YORK Solid State Starter is used. (See Forms 160.47-PW6, 160.47-PW2, Style C and 160.47-PW12, Style D.)
  - a. Starter to control center – L, 2, 110, 111, 112, 113, 114, and 115; 11 conductor shielded cable.
  - b. Starter to cooling pump – 2, 108, GRD.
14. Full load amperes for 1.5 KVA control power transformer (furnished by York International Corporation and factory wired) to be used with Notes 15, 16 and 17 are:

3-Phase Voltage	Hz	Control Power (5T) Transformer (Amps)
200/208	60	7.5
220/230/240	60	6.8
440/460/480	60	3.4
550/575/600	60	2.7
380/400/415	50	3.9

15. The branch circuit overcurrent protection device(s) for the YORK Solid State Starter must be a time delay type with a rating which is the smaller of the two values listed below (a) or (b):
  - a. The next standard fuse/breaker rating above:  
1.5 (Compressor-Motor FLA) + Control Transformer Amps
  - b. A rating limited by the starter size as follows:

Starter Model No.	Max. Fuse/Breaker Size (Amps)
SSS 7L	450
SSS 14L	800
SSS 26L	1600
SSS 33L	1600

Where 150% factor is per U.L. Standard 465 (7th Edition), Para. 45.1; FLA is per Note 7; control power transformer Amps per Note 14.

16. The YORK Solid State Starter power wiring ampacity shall be calculated as follows.

Model YS minimum circuit ampacity:

$$\text{Ampacity} = 1.25 (\text{Compressor-Motor FLA}) + \text{Control Transformer Amps}$$

Where 125% factor per N.E.C. (Para. 440-33); FLA is per Note 7; control power transformer Amps per Note 14.

17. If the fused disconnect switch (FDS2) is not located in sight (N.E.C. Para. 440-14) of the YORK Solid State Starter, a non-fused disconnect switch (not shown) shall be located in sight of the Solid State Starter between FDS2 and the Solid State Starter. The ampere rating shall be determined as follows for the disconnect switch of FDS2: The larger of
  - a. Amp Rating = 1.15 (Compressor-Motor FLA + Control Transformer Amps)
  - or
  - b. The size required to mount the fuses determined in Note 15 (if a fused disconnect is employed).

Where 115% factor is per N.E.C. (Para. 440-12b (2)); FLA is per Note 7 and control power transformer Amps per Note 14. An optional factory mounted and wired disconnect switch within the SSS is available (see Note 8).

18. Control circuit wiring for 3M condenser water pump motor starter is shown for cooling only application.
19. The main power transformer should be adequately sized such that the transformer voltage drop does not exceed 10% during unit start-up. The supply voltage, at starter input terminals, during start-up must be maintained above the minimum value specified in the table. Note that while the YORK chiller will perform acceptably during startup with this amount of voltage drop, the performance of other equipment connected to the supply transformer could be adversely affected.

Three Phase Voltage	Hz	Minimum Voltage at Starter Input Terminals During Start-up
200/208	60	170
230/240	60	196
440/460/480	60	391
575/600	60	489
380	50	323
400	50	340
415	50	353

20. Automatic control of the chilled water pump by the Control Center is shown. Chilled water pump motor

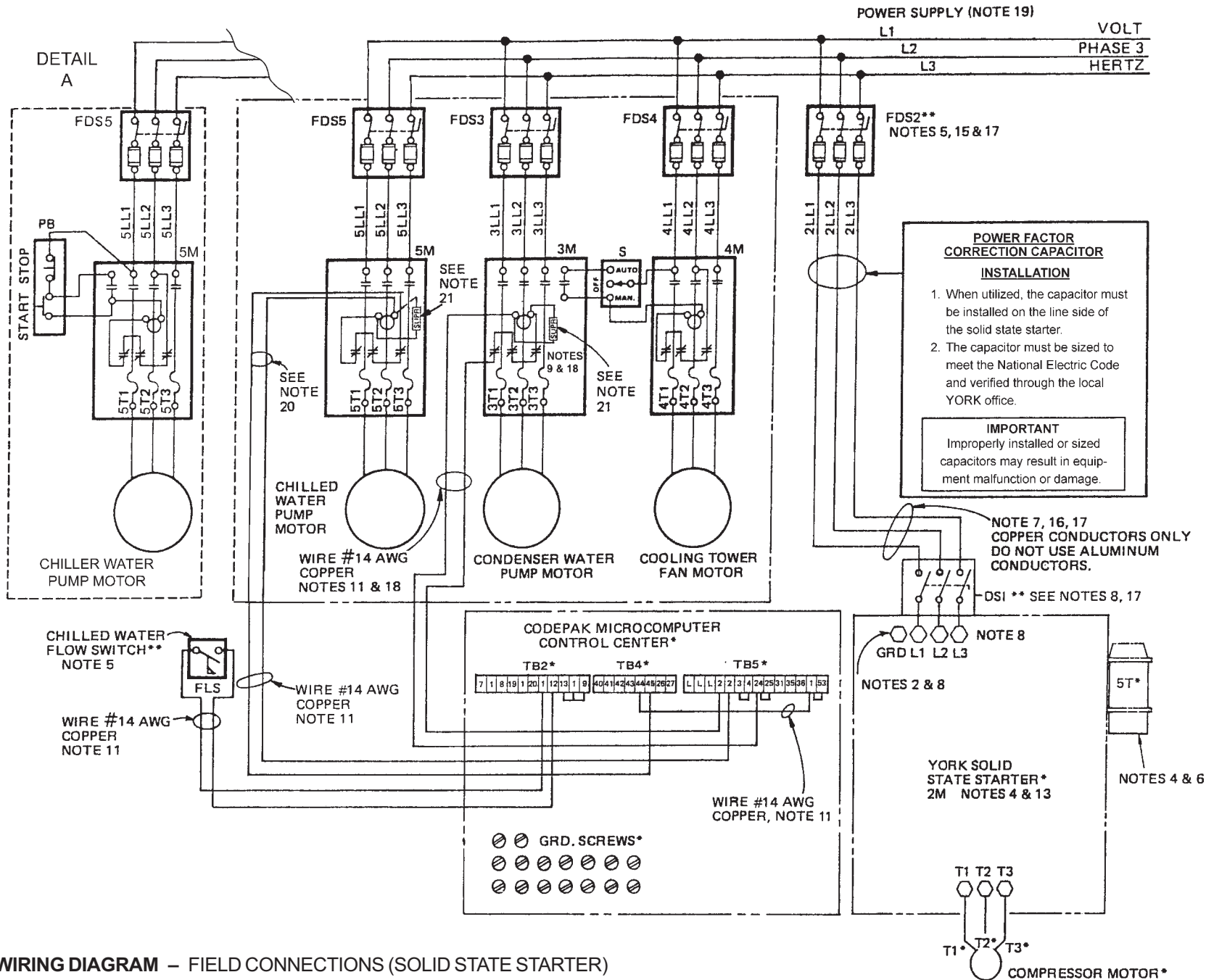

WIRING DIAGRAM – FIELD CONNECTIONS (SOLID STATE STARTER)

LD03608

starter (5M) holding coil to be furnished for 115V – 50/60 Hz. The power requirements for the water pump starter (5M) must be a maximum of 2 Amps inductive at 115VAC. If power requirements exceed this value, furnish coil for line voltage, and control relay with 115V coil.

Two chilled water pump operating modes are available via the CHW Pump programming jumper (J54) on the micro board. With J54 installed, the chilled water pump operates for 30 seconds prior to compressor start, during compressor operation, coastdown, and LWT cycling shutdowns. With J54

removed, the chilled water pump operates as above plus it operates during MULTI-UNIT and REMOTE/ LOCAL cycling shutdowns.

For manual chilled water pump control, connect a manual start/stop switch as shown in Detail A.

21. Each 115VAC field-connected inductive load, i.e. relay coil, motor starter coil, etc. shall have a transient suppressor wired (by others) in parallel with its coil, physically located at the coil. Spare transient suppressors are factory supplied in a bag attached to the top of the hinged panel in the MicroComputer Control Center.



Proud Sponsor  
of the 1998  
U.S. Olympic Team

36USC380