



ISOFLOW ABSORPTION CHILLERS

WIRING DIAGRAM

Supersedes: 155.16-W4 (698)

Form 155.16-W4 (502)

MODELS

STEAM

YIA-ST-1A1 THRU YIA-ST-14F3

HOT WATER

YIA-HW-1A1 THRU YIA-HW-14F3

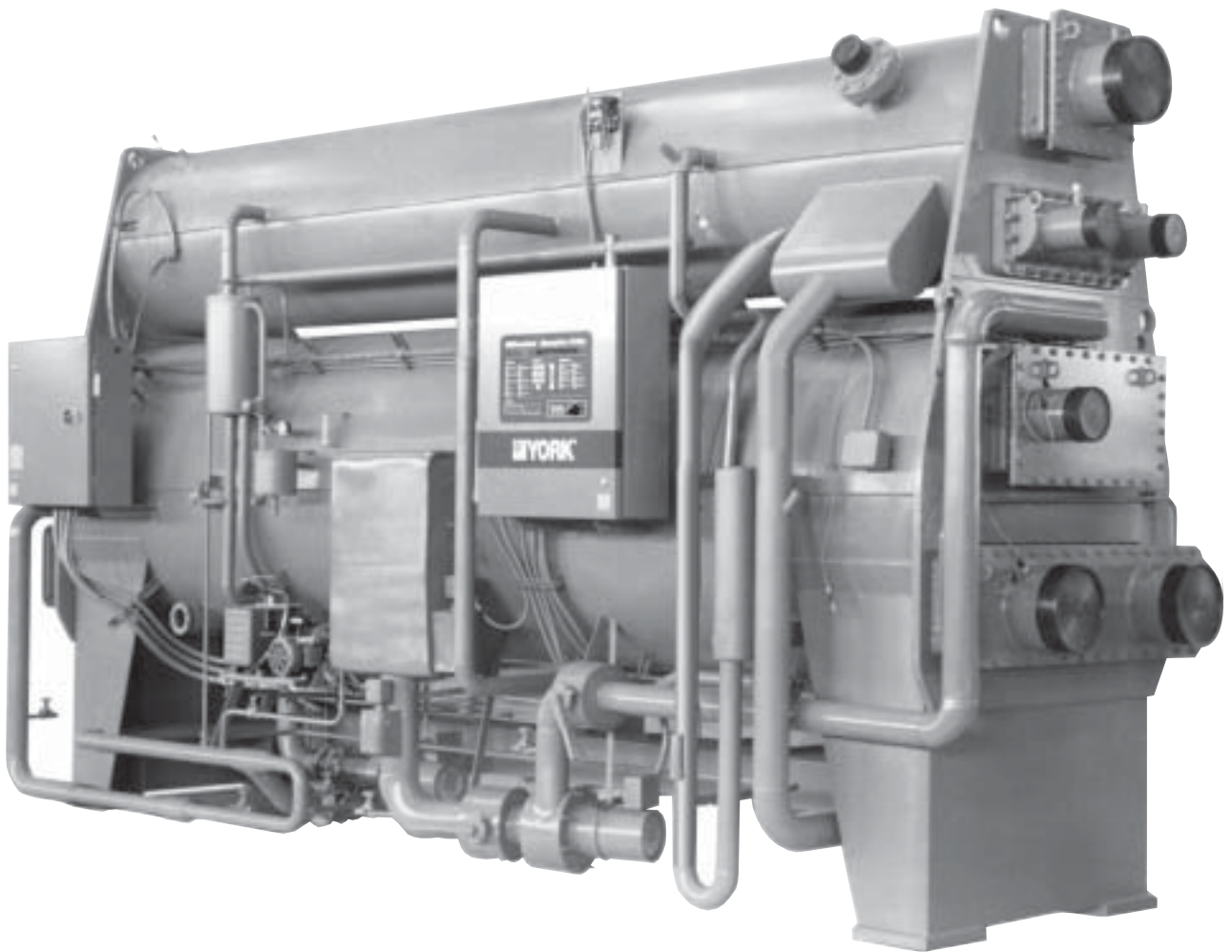

00101VIP

TABLE OF CONTENTS FOR DIAGRAMS

| | |
|---|--------|
| SECTION 1 (60 Hz IsoFlow Control Centers) | 4 |
| Legend for 60 & 50 Hz | 2 |
| Elementary Diagram | 4 |
| Digital Input Board | 5 |
| System Timing Chart | 5 |
| Power Supply Board | 6 |
| Keypad | 6 |
| Pressure-Temperature Chart | 7 |
| Microboard | 8-9 |
| I/O Expansion Board | 10 |
| MicroComputer Control Center | 12-13 |
| Connection Diagram | 14 |
| Incoming Power / Pump Connections | 15 |
| Control Valve Connections (Steam & Hot Water) | 16 |
| Power Panel Wiring Diagram | 17 |
| SECTION 2 (50 Hz IsoFlow Control Centers) | 18 |
| Elementary Diagram | 18 |
| Digital Input Board | 19 |
| System Timing Chart | 19 |
| Power Supply Board | 20 |
| Keypad | 20 |
| Pressure-Temperature Chart | 21 |
| Microboard | 22-23 |
| I/O Expansion Board | 24 |
| MicroComputer Control Center | 26-27 |
| Connection Diagram | 28 |
| Incoming Power / Pump Connections | 29 |
| Control Valve Connections (Steam & Hot Water) | 30 |
| Power Panel Wiring Diagram | 31 |
| Notes | 32 |

LEGEND FOR 50 & 60 HZ

| | |
|---|---|
| <p>IF REFRIGERANT LEVEL FLOAT SWITCH 3F REFRIGERANT PUMP CUT-OUT FLOAT SWITCH IM 3 PHASE SOLUTION PUMP STARTER (MOUNTED IN POWER PANEL) 2M 3 PHASE REFRIGERANT PUMP MOTOR STARTER (MOUNTED IN POWER PANEL) 3M 3 PHASE PURGE PUMP MOTOR STARTER (MOUNTED IN POWER PANEL) IR STEAM/HOT WATER SHUTOFF SOLENOID VALVE CONTROL RELAY 2R FIRST STAGE GENERATOR HIGH TEMP. CUT-OUT RELAY 3R RELAY 2SOL STABILIZER REFRIGERANT SOLENOID 3SOL REFRIGERANT LEVEL SOLENOID 4SOL STEAM/HOT WATER SHUTOFF SOLENOID</p> <p>6SOL STEAM CONDENSATE DRAIN VALVE SOLENOID (STEAM ONLY) ISS DPDT 3 POSITION ROCKER SWITCH IT CLASS 2 POWER SUPPLY TRANSFORMER CHFLS CHILLED WATER FLOW SWITCH CUT-OUT (BY YORK/WIRING BY OTHERS) FU FUSE HT STEAM OR HOT WATER SUPPLY TEMPERATURE HTI HIGH TEMPERATURE CUTOUT SWITCH HPI GENERATOR HIGH PRESSURE CUT-OUT SWITCH HP2 STEAM SUPPLY PRESSURE TRANSDUCER LRT LOW REFRIGERANT TEMPERATURE CUT-OUT SWITCH LWT LOW WATER TEMPERATURE CUT-OUT (PROVIDED BY RTI) MOV METAL OXIDE VARISTOR OL MOTOR OVERLOAD PT1,PT2-PT4 PRESSURE TRANSDUCER RTI-RT9 RESISTANCE TEMPERATURE SENSING ELEMENT UPS UNINTERRUPTABLE POWER SUPPLY SUPR TRANSIENT SUPPRESSOR</p> | <p>TB1,TB3,TB6 TERMINAL BLOCK, FACTORY WIRING - TB2,TB4,TB5 TERMINAL BLOCK, FIELD CONNECTION - TB7 TERMINAL BLOCK, FIELD CONNECTION, STEAM VALVE ACTUATOR - TERMINAL BLOCK LOCATED IN POWER PANEL</p> <p>----- FIELD WIRING ===== FACTORY WIRING - - - - - CIRCUIT BOARD OR ENCLOSURE BOUNDARY</p> <p> JACK (J1,J2,...) JACK (P1,P2,...) WIRE ENTRANCE HOLE IN CONTROL PANEL</p> <p>----- OPTION (WHEN SUPPLIED) BY YORK. ----- MECHANICAL LINKAGE SHIELDED CABLE METAL OXIDE VARISTOR (MOV)</p> <p>MTH1, MTH2 MOTOR WINDING THERMOSTAT FCV FLOW CONTROL VALVE</p> |
|---|---|

IMPORTANT!

READ BEFORE PROCEEDING!

GENERAL SAFETY GUIDELINES

This equipment is a relatively complicated apparatus. During installation, operation, maintenance or service, individuals may be exposed to certain components or conditions including, but not limited to: refrigerants, oils, materials under pressure, rotating components, and both high and low voltage. Each of these items has the potential, if mis-used or handled improperly, to cause bodily injury or death. It is the obligation and responsibility of operating / service personnel to identify and recognize these inherent hazards, protect themselves, and proceed safely in completing their tasks. Failure to comply with any of these requirements could result in serious damage to the equipment and the property in which it is situated, as well as severe personal injury or death to themselves and people at the site.

This document is intended for use by owner-authorized operating/service personnel. It is expected that this individual possesses independent training that will enable them to perform their assigned tasks properly and safely. It is essential that, prior to performing any task on this equipment, this individual shall have read and understood this document and any referenced materials. This individual shall also be familiar with and comply with all applicable governmental standards and regulations pertaining to the task in question.

SAFETY SYMBOLS

The following symbols are used in this document to alert the reader to areas of potential hazard:



DANGER indicates an imminently hazardous situation which, if not avoided, will result in death or serious injury.



WARNING indicates a potentially hazardous situation which, if not avoided, could result in death or serious injury.



CAUTION identifies a hazard which could lead to damage to the machine, damage to other equipment and/or environmental pollution. Usually an instruction will be given, together with a brief explanation.



NOTE is used to highlight additional information which may be helpful to you.

CHANGEABILITY OF THIS DOCUMENT

In complying with YORK's policy for continuous product improvement, the information contained in this document is subject to change without notice. While YORK makes no commitment to update or provide current information automatically to the manual owner, that information, if applicable, can be obtained by contacting the nearest YORK Applied Systems Service office.

It is the responsibility of operating/service personnel to verify the applicability of these documents to the equipment in question. If there is any question in the mind of operating/service personnel as to the applicability of these documents, then prior to working on the equipment, they should verify with the owner whether the equipment has been modified and if current literature is available.

ISOFLOW CONTROL CENTER ELEMENTARY DIAGRAM (60 HZ)

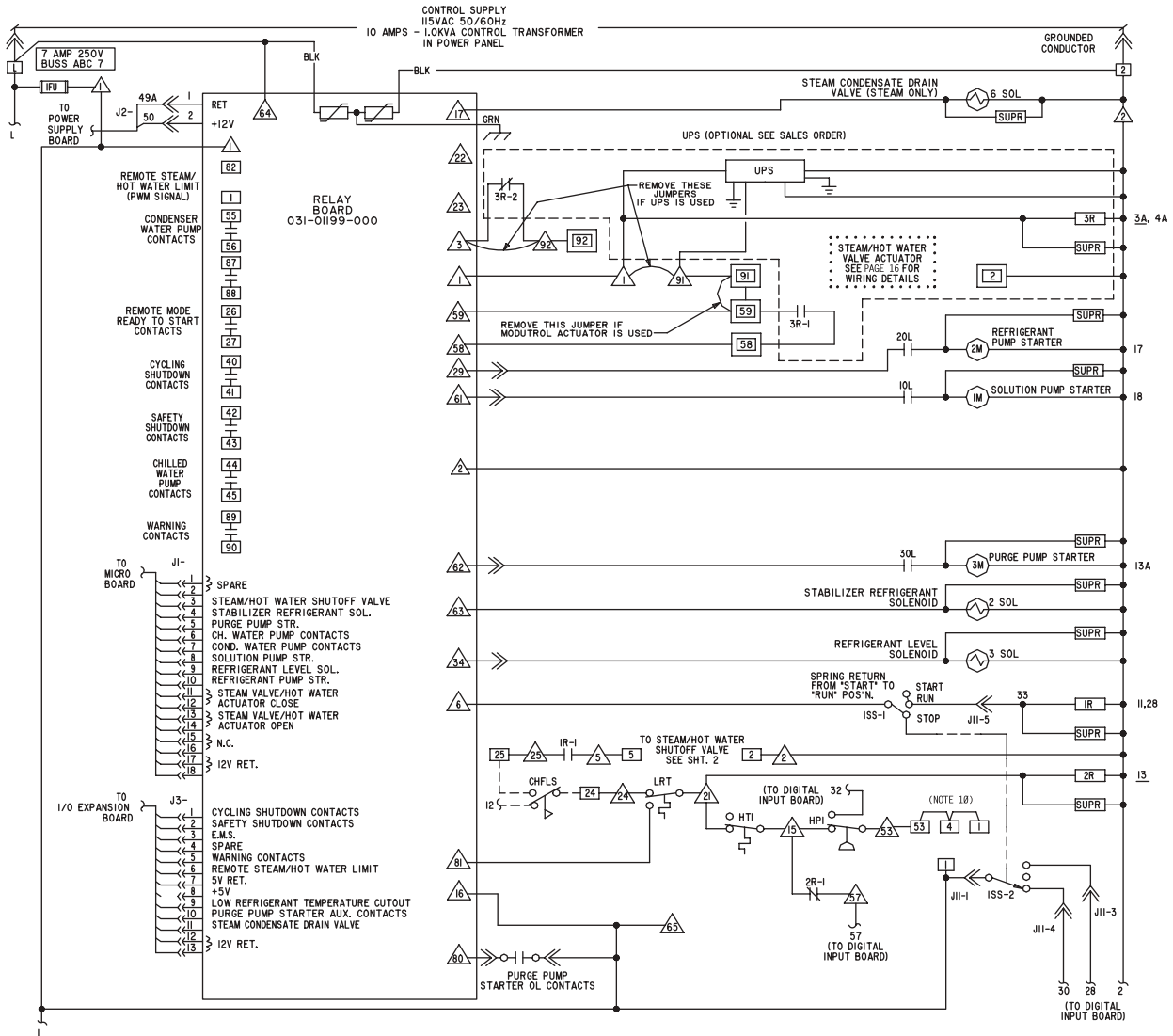

LD07859

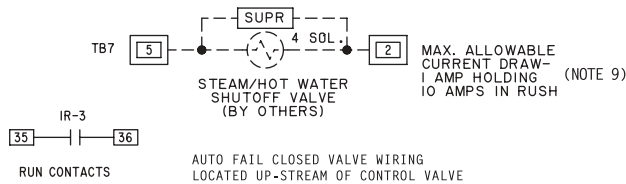

DIAGITAL INPUT BOARD (60 HZ)

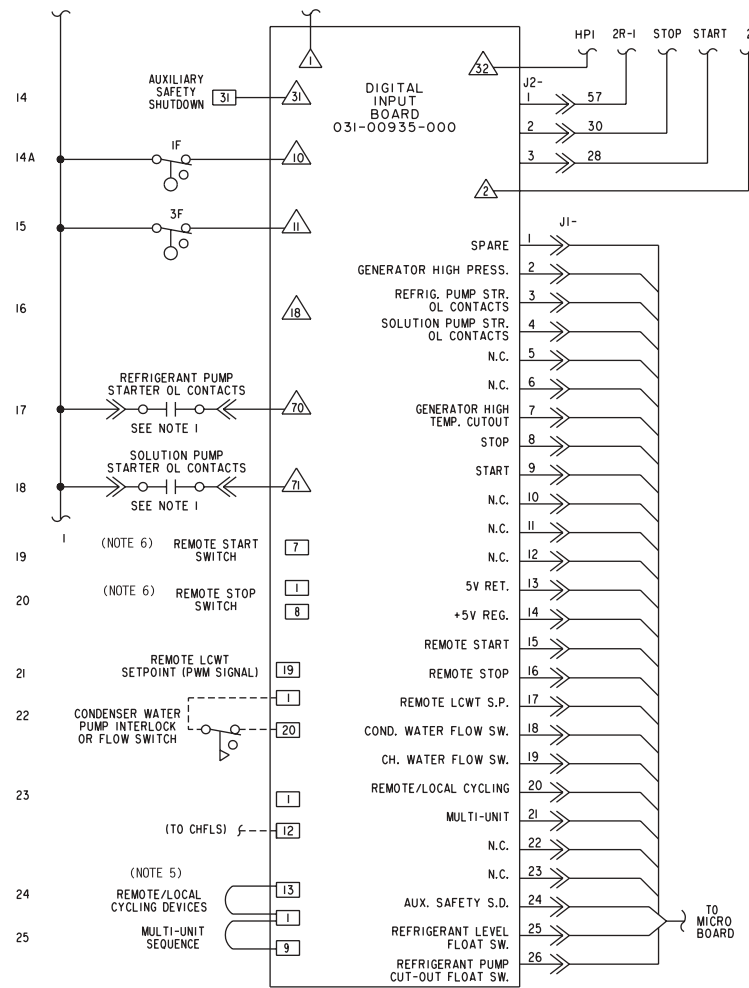

Id07877

SYSTEM TIMING CHART (60 HZ)

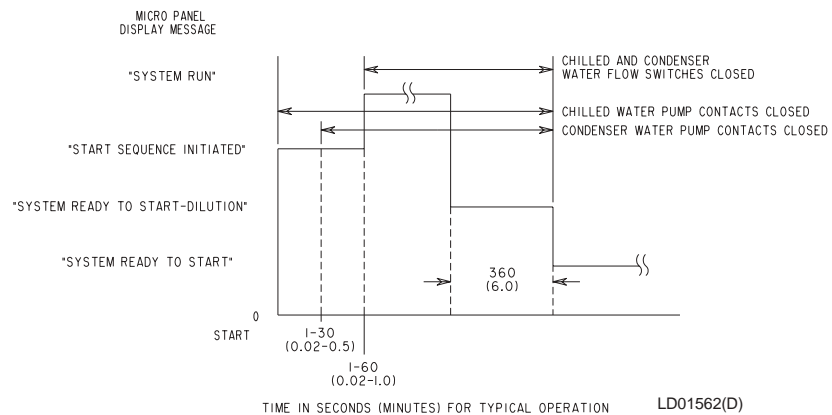

LD01562(D)

POWER SUPPLY BOARD (60 HZ)

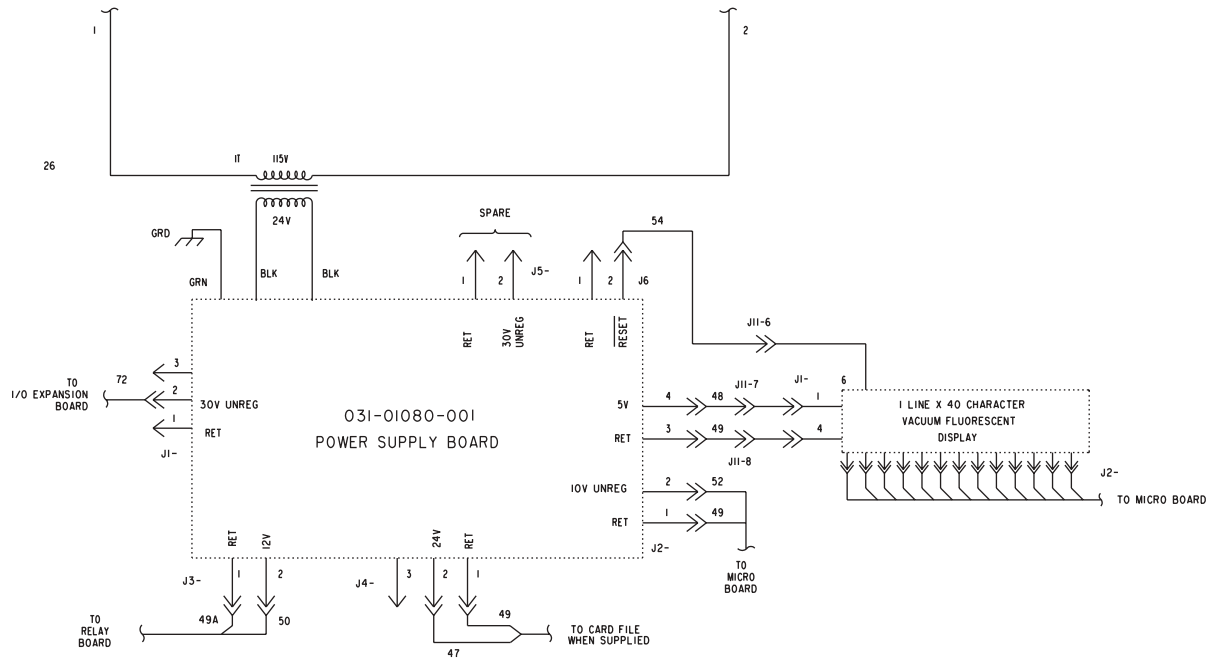

KEYPAD (60 HZ)

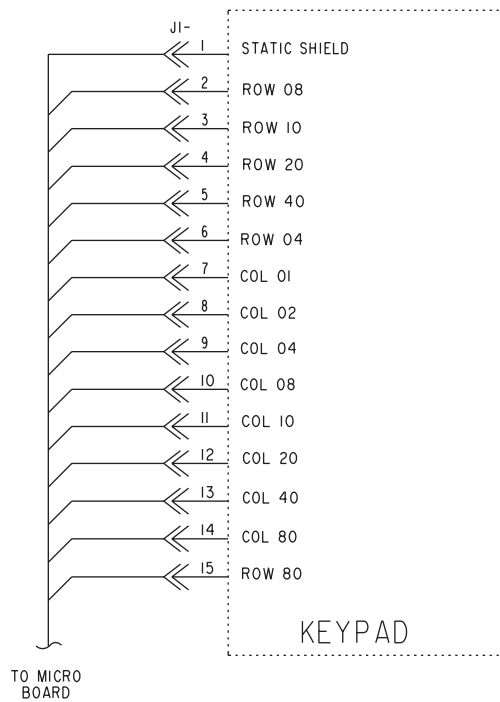

LD07876

PRESSURE-TEMPERATURE CHART (60 HZ)

| APPLICATION | | DEVICE | UNITS | OPERATING POINT | | | |
|--------------------------------|-----------------------------|--------|-----------------|---|---|---|------------------------------------|
| STEAM FIRED UNITS | HOT WATER UNITS | | | ON RISE (INCREASING) | | ON FALL (DECREASING) | |
| X | X | HP1 | mm Hg Abs. | Cut-Out 710 | | Cut-In 40 | |
| X | X | PT1 | mm Hg Abs. | Cut-Out 775.7 | HP Warning Forced Unload to 30% FCV | HP Warning Reset Unit Allowed to Load | Reset 770.5 |
| X | X | HT1 | Deg. F / Deg. C | Cut-Out 330 / 165.6 | | Cut-In (Manual Reset) 326 / 163.3 | |
| X | X | LRT | Deg. F / Deg. C | Cut-In 37 / 2.7* 37 / 2.7** | LRT Override Allow Loading 36 / 2.2* | LRT override Inhibit Loading 35.5 / 1.9* | Cut-Out 33 / 0.6* 33 / 0.6** |
| X | X | LWT | Deg. F / Deg. C | 2.0 / 1.1 Above the Chilled Water Temp. Setpoint | | 2.0 / 1.1 Below the Chilled Water Temp. Setpoint: When the Setpoint is Raised, LWT = the Previous Valve for 30 min. | |
| X | | PT2 | PSIA / Kpa | Cut-Out 29.0 / 199.9 | PT2 Steam Supply Warning 26.0 / 179.3 | PT2 Steam Supply Reset 25.5 / 175.8 | Cut-In 28.9 / 199.3 |
| | X (Std. Temp. Generator) | HT+ | Deg. F / Deg. C | Cut-Out 255 / 124 | Hot Water Supply Warning 250 / 121.1 | Hot Water Supply Reset 249.5 / 120.8 | Cut-In 254 / 123.3 |
| | X++ (Hi-Temp. Generator) | HT+ | Deg. F / Deg. C | Cut-Out 270 / 132.2 | Hot Water Supply Warning 266 / 130 | Hot Water Supply Reset 265.5 / 129.7 | Cut-In 269 / 131.7 |
| X (Std. Temp. Generator) | | HT+ | Deg. F / Deg. C | Cut-Out 290 / 143.3 | Steam Supply Warning 285 / 140.6 | Steam Supply Reset 284 / 140 | Cut-In 289 / 142.8 |
| X++ (Hi-Temp. Generator) | | HT+ | Deg. F / Deg. C | Cut-Out 340 / 171.1 | Steam Supply Warning 337 / 169.4 | Steam Supply Reset 336 / 168.9 | Cut-In 339 / 170.1 |

NOTES:

- * Function provided by refrigerant temperature sensor (RT8)
- ** Function provided by refrigerant temperature switch (LRT)
- + Function provided by steam or hot water supply temperature sensor (RT7)
- ++ Microboard jumper JP5 must be cut to activate higher settings.

MICROBOARD (60 HZ)

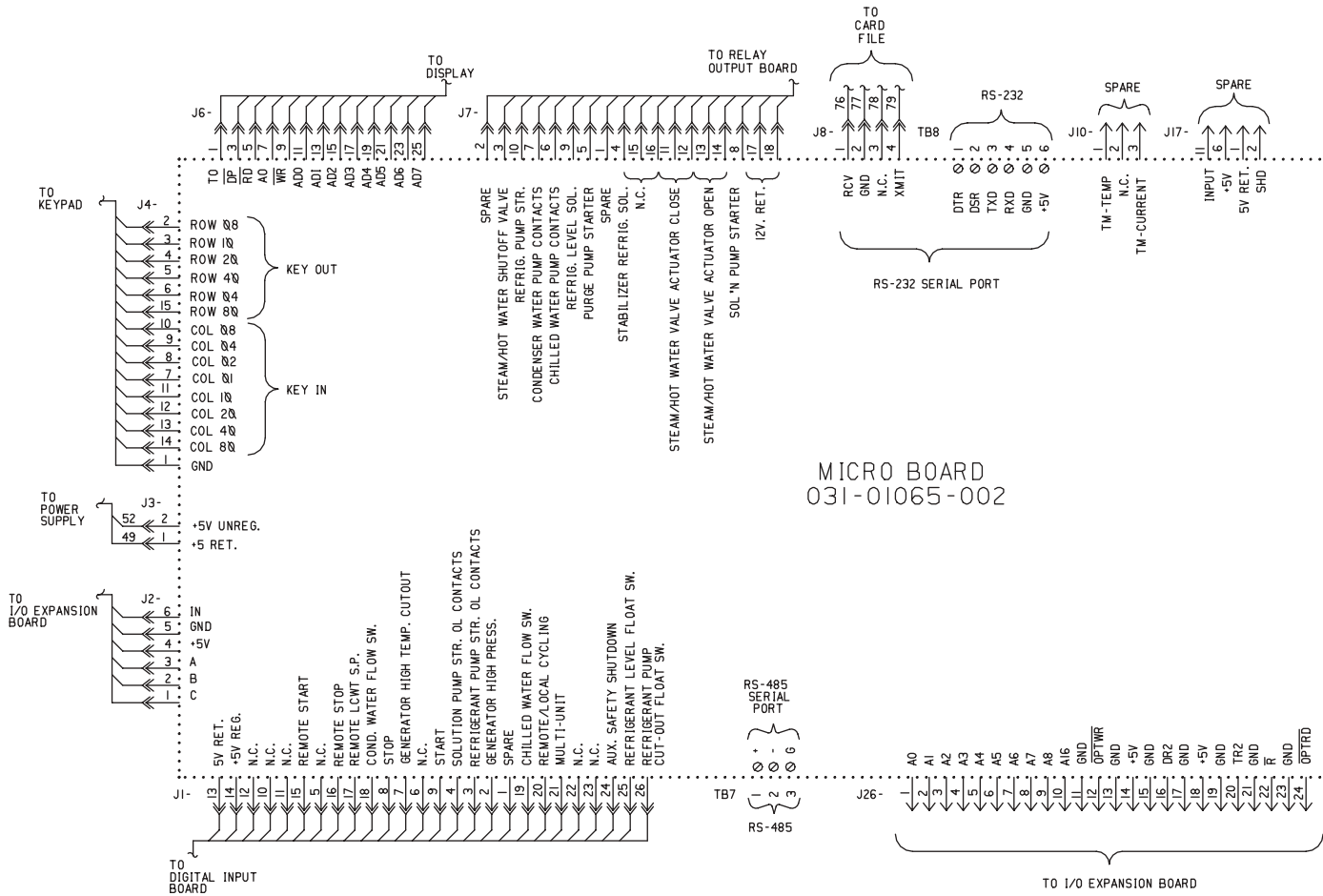

MICRO BOARD
031-01065-002

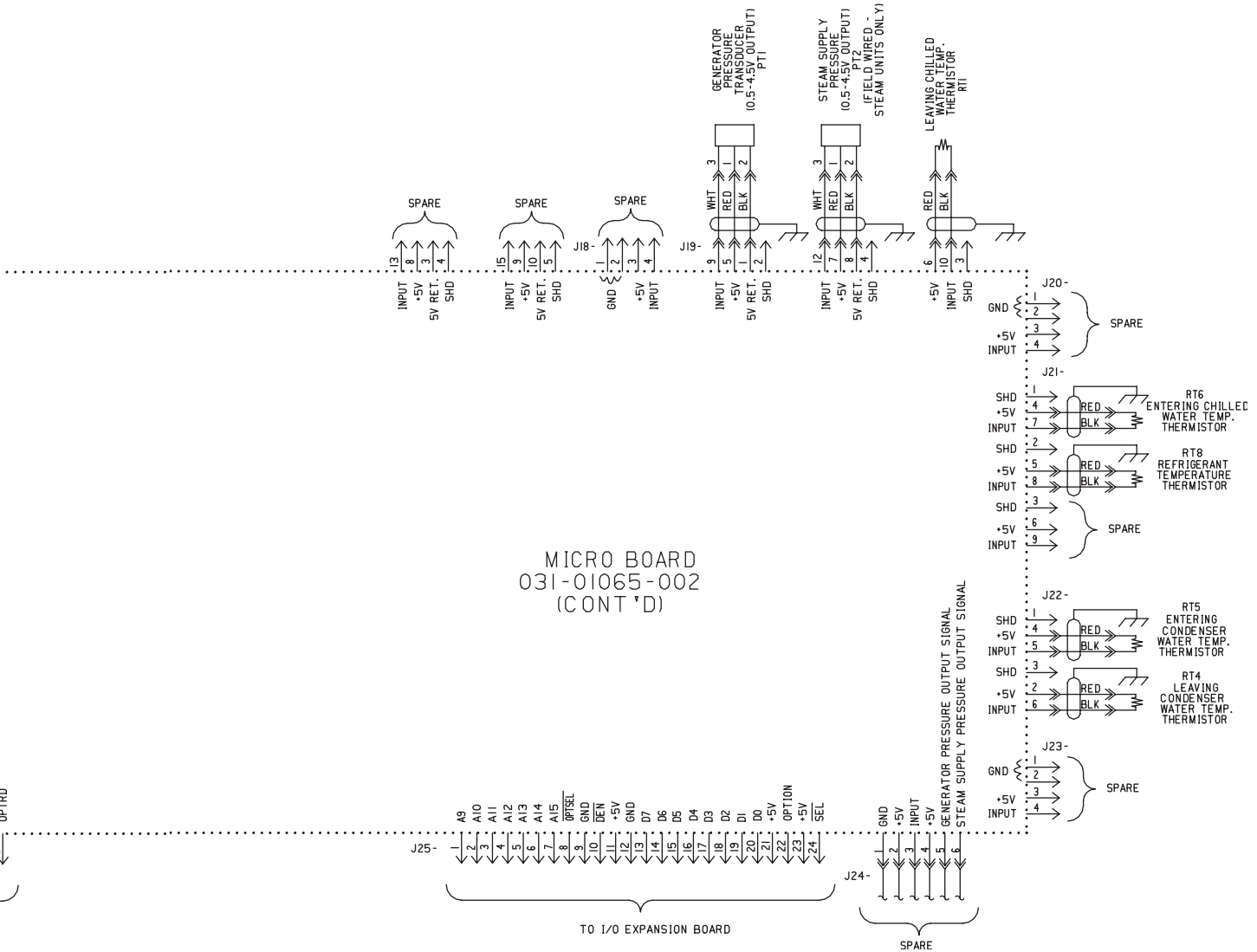

LD07860

This page intentionally left blank.

MICROCOMPUTER CONTROL CENTER (60 HZ)

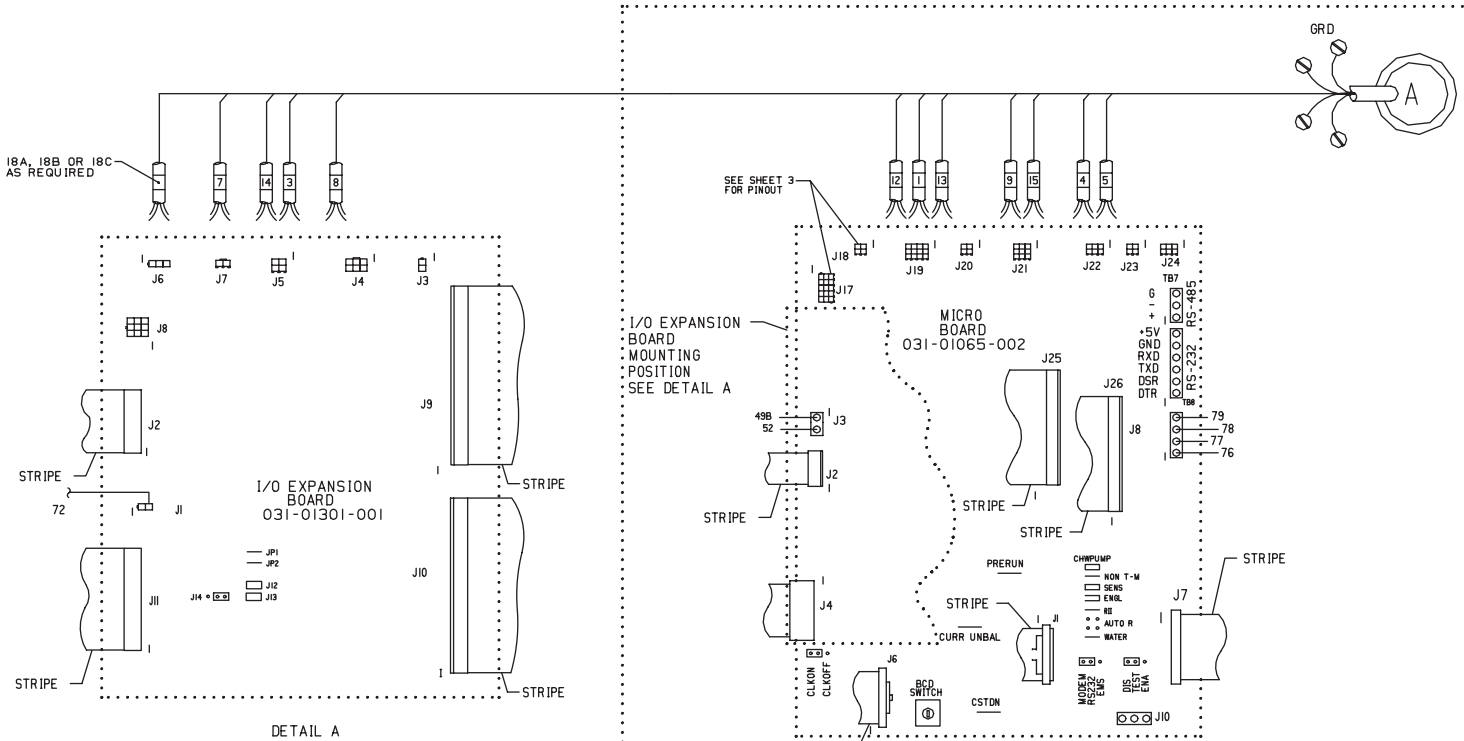

DETAIL A

- TO REMOTE MODE READY TO START CONTACTS 26,27 (SEE NOTES 11,12)
- TO REMOTE LCWT SET POINT (PWM SIGNAL) 1,19 (SEE NOTES 1,7)
- TO REMOTE STEAM/HOT WATER LIMIT (PWM SIGNAL) 1,82 (NOTES 1,7)
- TO CHILLED WATER PUMP CONTACTS 44,45 (NOTES 11,12)
- TO CYCLING SHUTDOWN CONTACTS 40,41 (SEE NOTES 11,12)
- TO RUN CONTACTS 35,36 (SEE NOTES 8,12)
- TO CONDENSER PUMP CONTACTS 55,56 (SEE NOTES 11,12)
- TO AUXILIARY SAFETY SHUTDOWN CONTACTS 4,31,53 (SEE NOTES 1,7)
- TO CHILLED WATER FLOW SWITCH, SUPPLIED BY YORK - SHIPPED LOOSE FOR INSTALLATION BY OTHERS 24,25,12 (SEE NOTE 7)
- TO SAFETY SHUTDOWN CONTACTS 42,43 (SEE NOTES 11,12)
- TO CONTACTS THAT CYCLE UNIT 1,7,8,13 (SEE NOTES 5,6,7)
- TO MULTI-UNIT SEQUENCE CONTACTS 1,9 (SEE NOTES 1,7)
- TO CONDENSER WATER PUMP INTERLOCK OR FLOW SWITCH 1,20 (SEE NOTE 7)
- TO WARNING CONTACTS 89,90 (SEE NOTES 11,12)
- TO STEAM/HOT WATER VALVE ACTUATOR, SUPPLIED BY YORK - SHIPPED LOOSE FOR INSTALLATION BY OTHERS 91,2,92,58,59 FOR MODUTROL ACTUATOR, 2,92,58 FOR ALL OTHER ACTUATORS (SEE NOTE 12 ON SHT. 4)
- TO STEAM/HOT WATER SHUTOFF VALVE 5,2 (SEE NOTES 9,12)

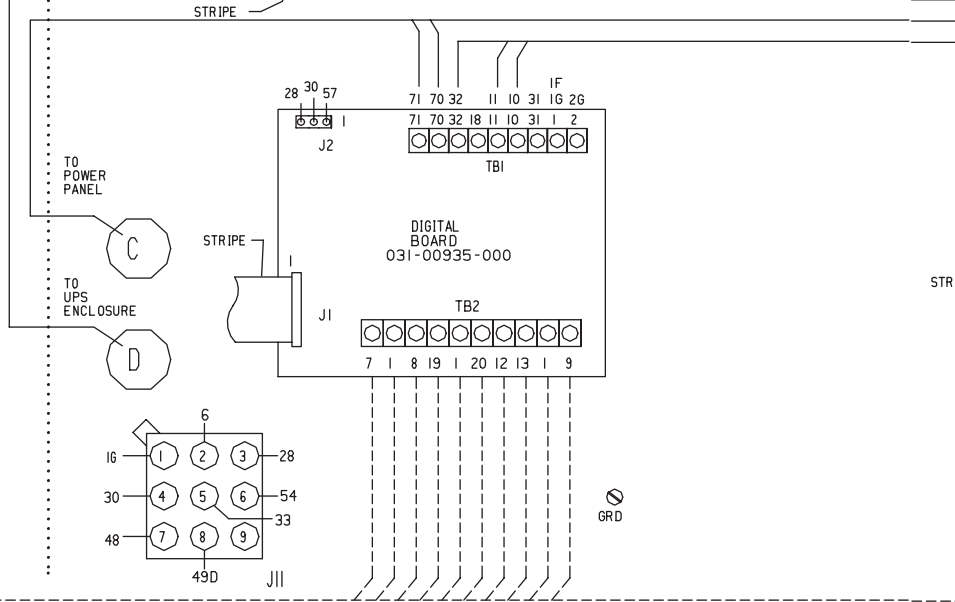

MICROCOMPUTER CONTROL CENTER

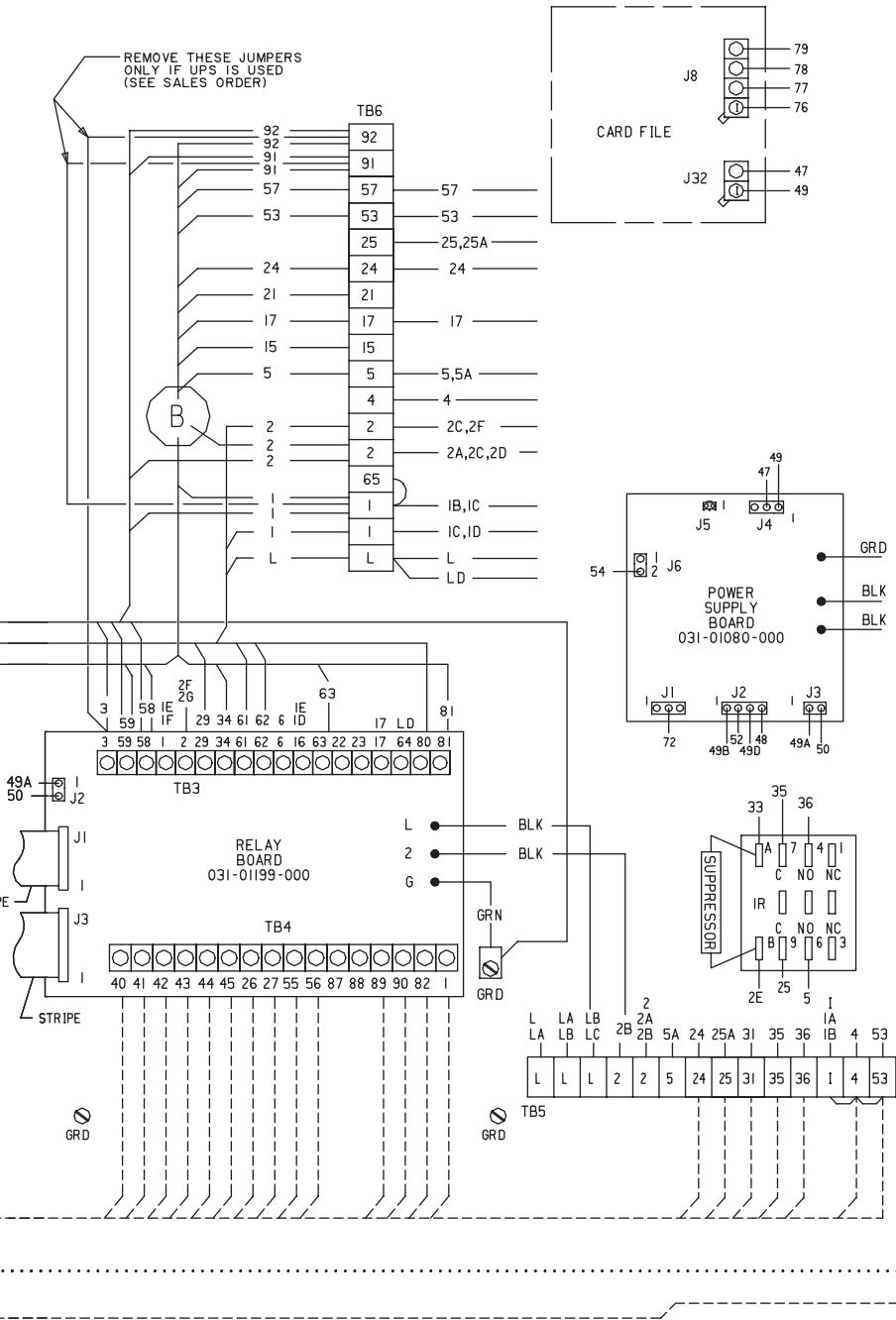

DOOR OPEN (REAR SIDE OF DOOR)

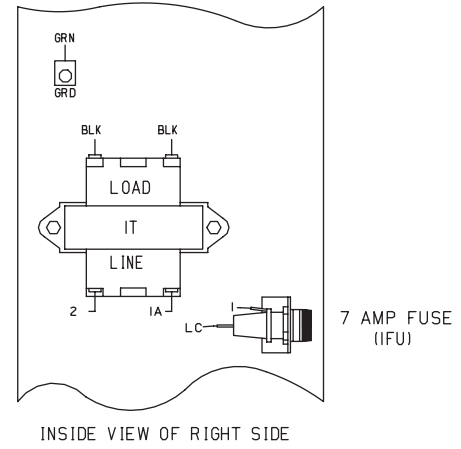
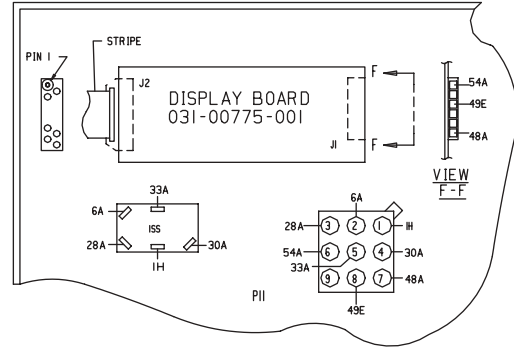

INCOMING POWER / PUMP CONNECTIONS (60 HZ)

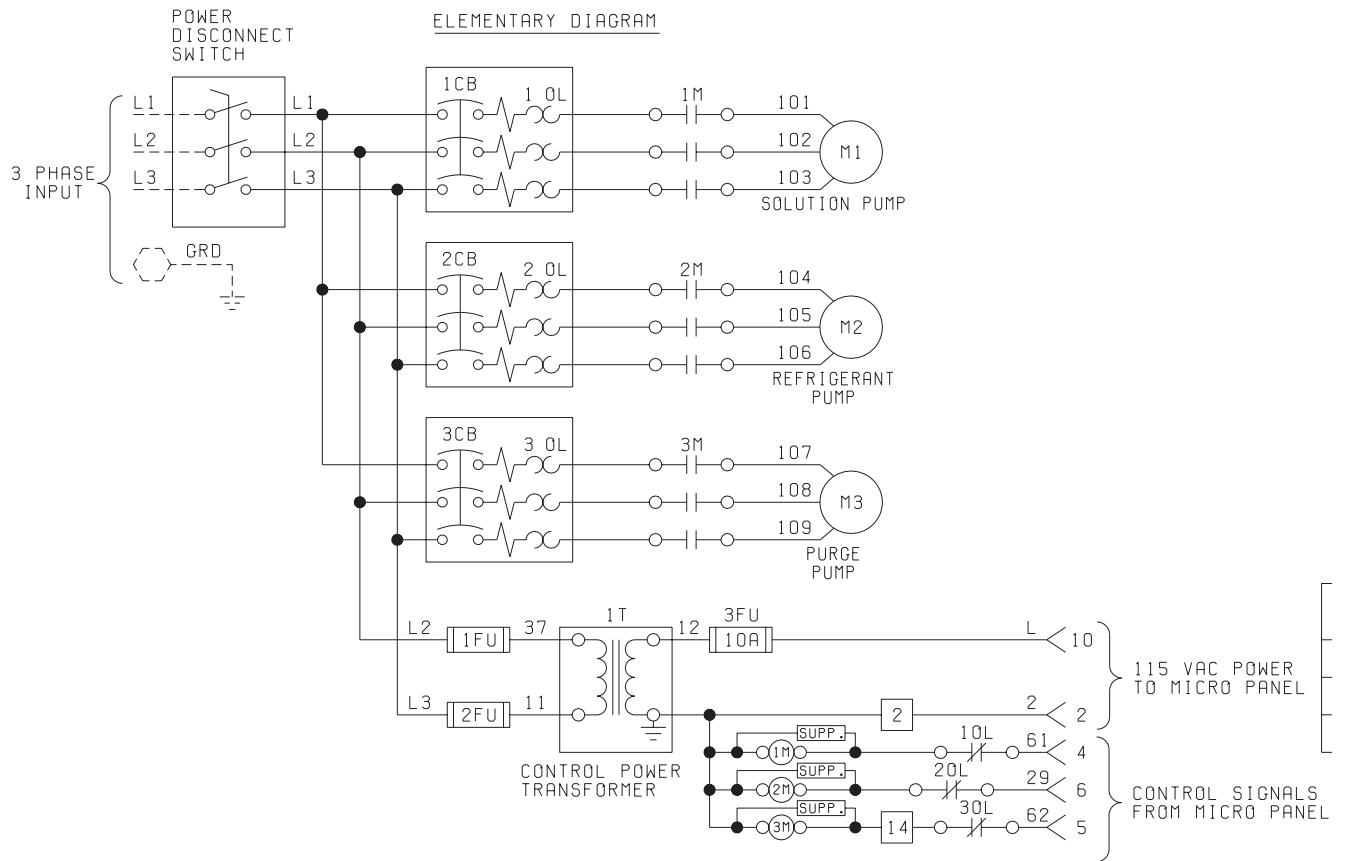

LD01559(D)

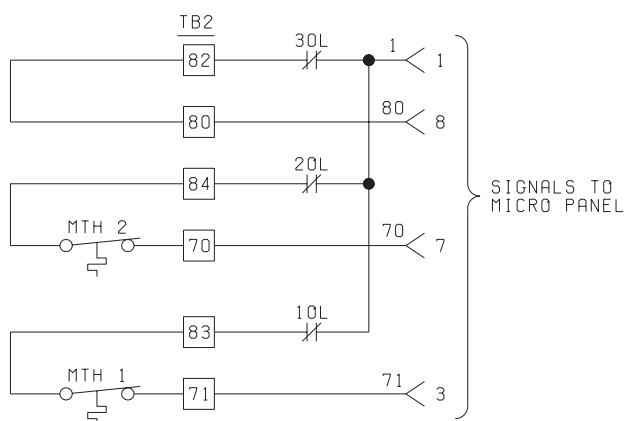

LD01559(D)

| PRIMARY VOLTS | FUSE INFO. | |
|----------------|------------|-----|
| | 1FU | 2FU |
| 208V-3PH-60HZ. | 12A | 12A |
| 230V-3PH-60HZ. | 10A | 10A |
| 460V-3PH-60HZ. | 5A | 5A |

LD01559(D)

POWER PANEL WIRING DIAGRAM (60 HZ)

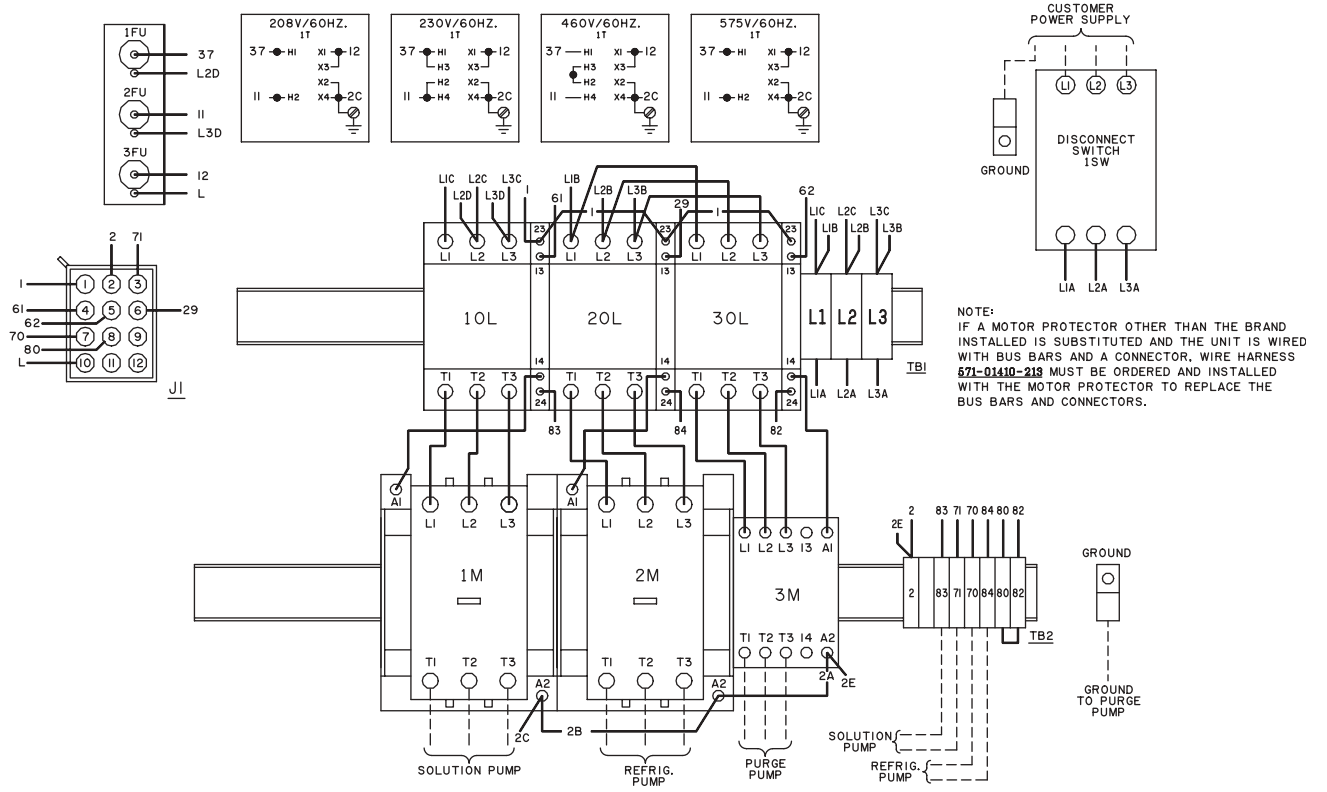

SECTION 2

ISOFLOW CONTROL CENTER ELEMENTARY DIAGRAM (50 HZ)

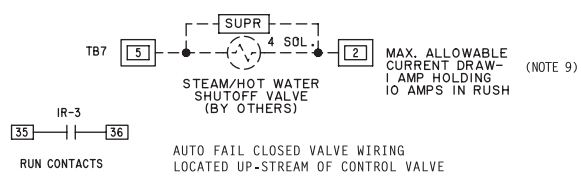
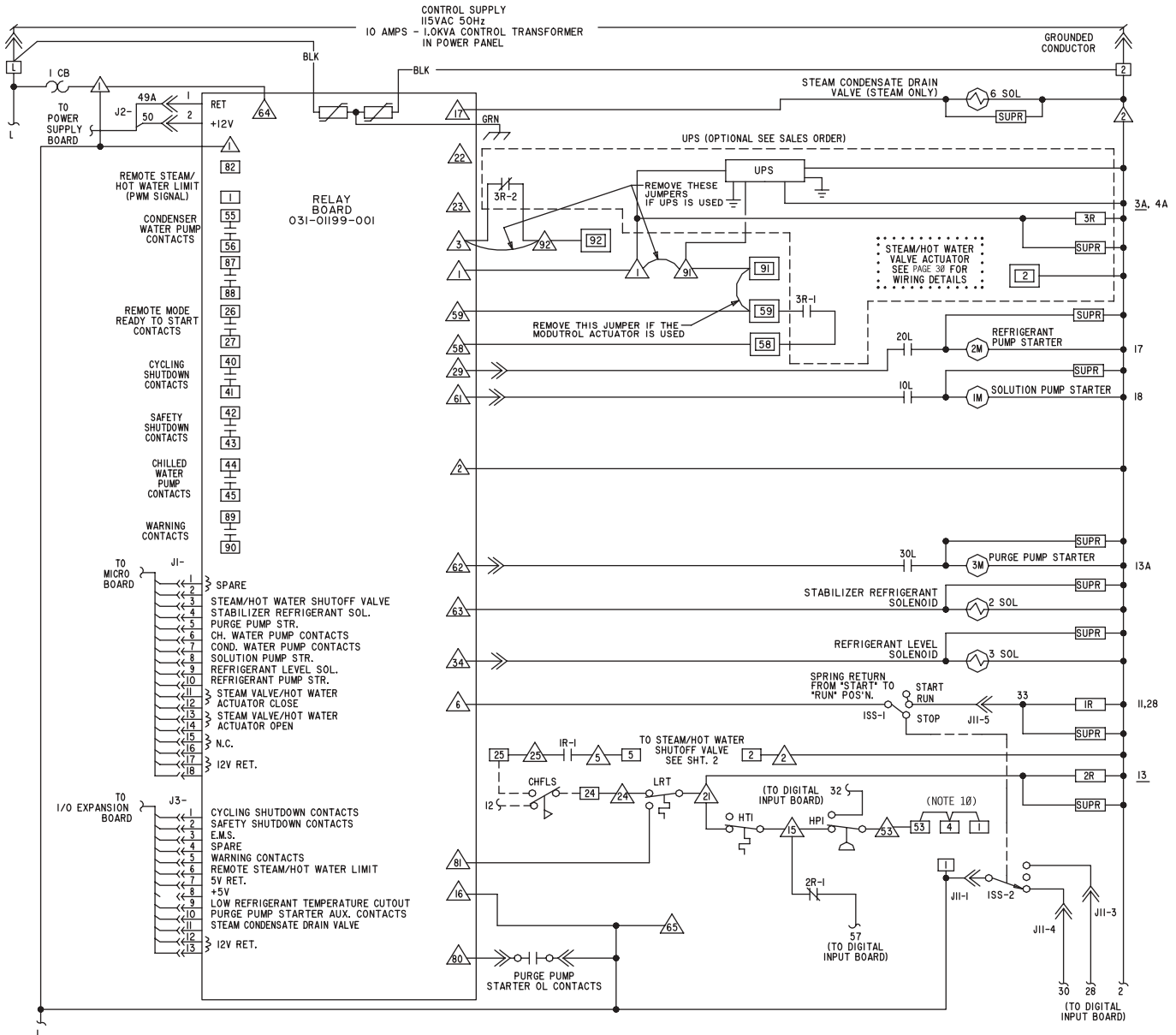

LD07851

DIGITAL INPUT BOARD (50 HZ)

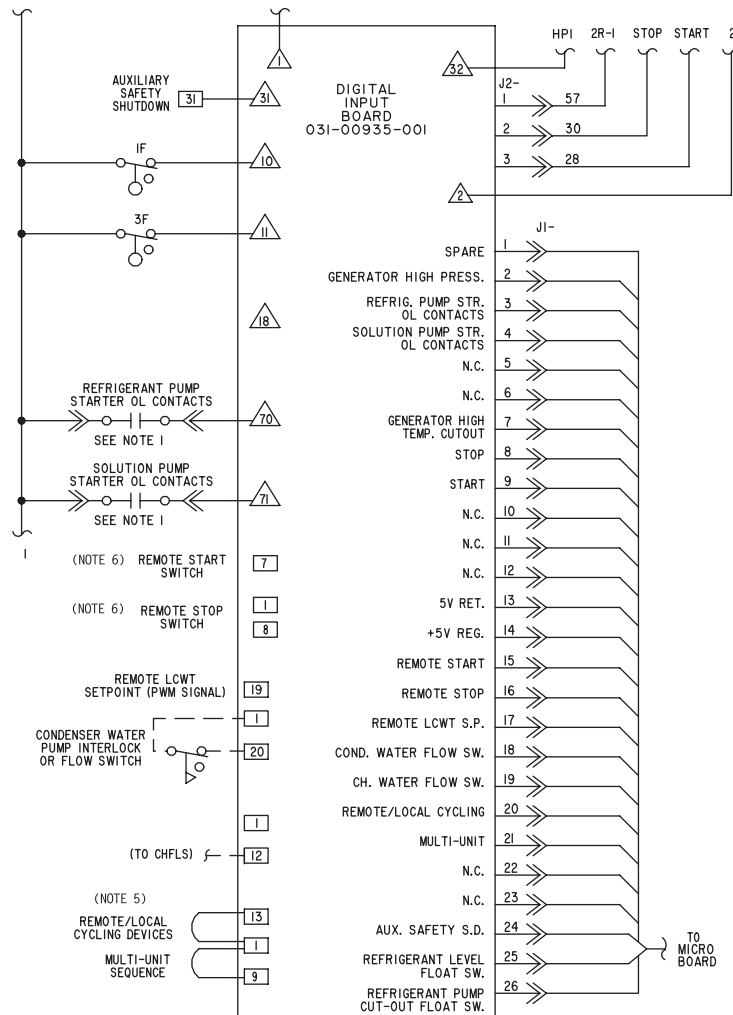

SYSTEM TIMING CHART (50 HZ)

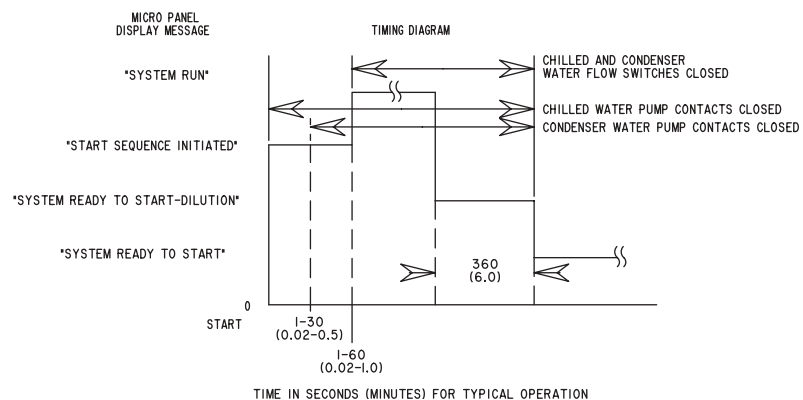

LD07852

POWER SUPPLY BOARD (50 HZ)

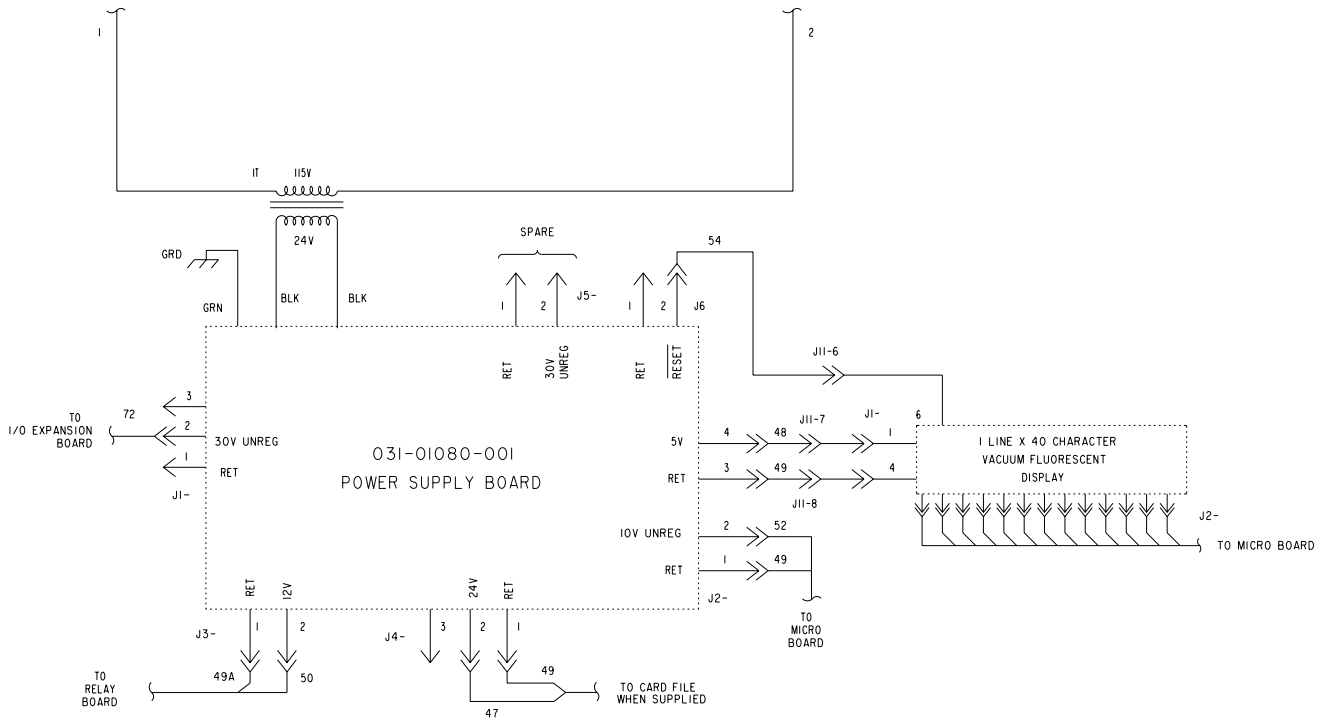

LD03120

KEYPAD (50 HZ)

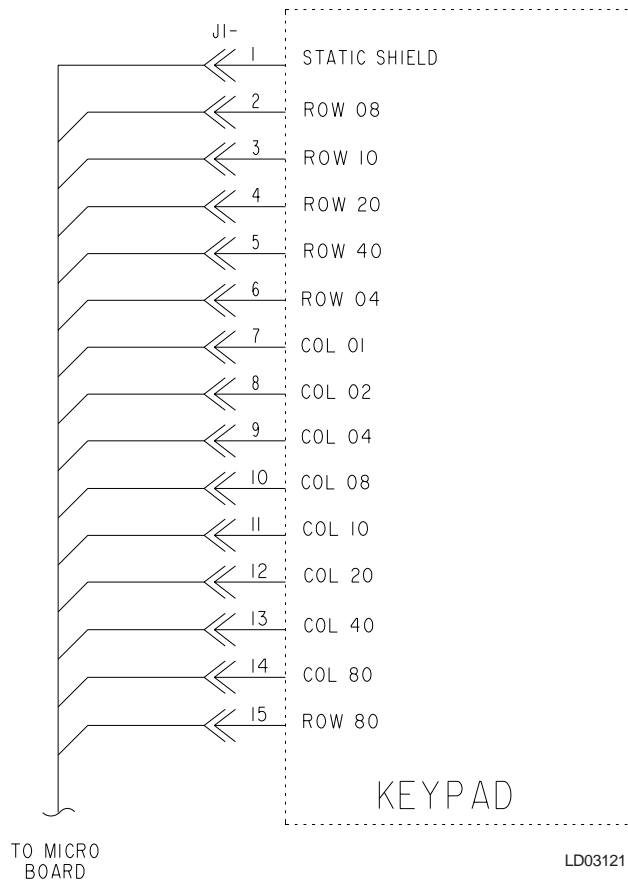

LD03121

PRESSURE-TEMPERATURE CHART (50 HZ)

| APPLICATION | | DEVICE | UNITS | OPERATING POINT | | | |
|--------------------------------|-----------------------------|--------|-----------------|---|---|---|---------------------------------|
| STEAM FIRED UNITS | HOT WATER UNITS | | | ON RISE (INCREASING) | | ON FALL (DECREASING) | |
| X | X | HP1 | mm Hg Abs. | Cut-Out 710 | | Cut-In 40 | |
| X | X | PT1 | mm Hg Abs. | Cut-Out 775.7 | HP Warning Forced Unload to 30% FCV | HP Warning Reset Unit Allowed to Load | Reset 770.5 |
| X | X | HT1 | Deg. F / Deg. C | Cut-Out 330 / 165.6 | | Cut-In (Manual Reset) 326 / 163.3 | |
| X | X | LRT | Deg. F / Deg. C | Cut-In 37 / 2.7* 37 / 2.7** | LRT Override Allow Loading 36 / 2.2* | LRT override Inhibit Loading 35.5 / 1.9* | Cut-Out 33 / 0.6* 33 / 0.6** |
| X | X | LWT | Deg. F / Deg. C | 2.0 / 1.1 Above the Chilled Water Temp. Setpoint | | 2.0 / 1.1 Below the Chilled Water Temp. Setpoint: When the Setpoint is Raised, LWT = the Previous Valve for 30 min. | |
| X | | PT2 | PSIA / Kpa | Cut-Out 29.0 / 199.9 | PT2 Steam Supply Warning 26.0 / 179.3 | PT2 Steam Supply Reset 25.5 / 175.8 | Cut-In 28.9 / 199.3 |
| | X (Std. Temp. Generator) | HT+ | Deg. F / Deg. C | Cut-Out 255 / 124 | Hot Water Supply Warning 250 / 121.1 | Hot Water Supply Reset 249.5 / 120.8 | Cut-In 254 / 123.3 |
| | X++ (Hi-Temp. Generator) | HT+ | Deg. F / Deg. C | Cut-Out 270 / 132.2 | Hot Water Supply Warning 266 / 130 | Hot Water Supply Reset 265.5 / 129.7 | Cut-In 269 / 131.7 |
| X (Std. Temp. Generator) | | HT+ | Deg. F / Deg. C | Cut-Out 290 / 143.3 | Steam Supply Warning 285 / 140.6 | Steam Supply Reset 284 / 140 | Cut-In 289 / 142.8 |
| X++ (Hi-Temp. Generator) | | HT+ | Deg. F / Deg. C | Cut-Out 340 / 171.1 | Steam Supply Warning 337 / 169.4 | Steam Supply Reset 336 / 168.9 | Cut-In 339 / 170.1 |

NOTES:

- * Function provided by refrigerant temperature sensor (RT8)
- ** Function provided by refrigerant temperature switch (LRT)
- + Function provided by steam or hot water supply temperature sensor (RT7)
- ++ Microboard jumper JP5 must be cut to activate higher settings.

MICROBOARD (50 HZ)

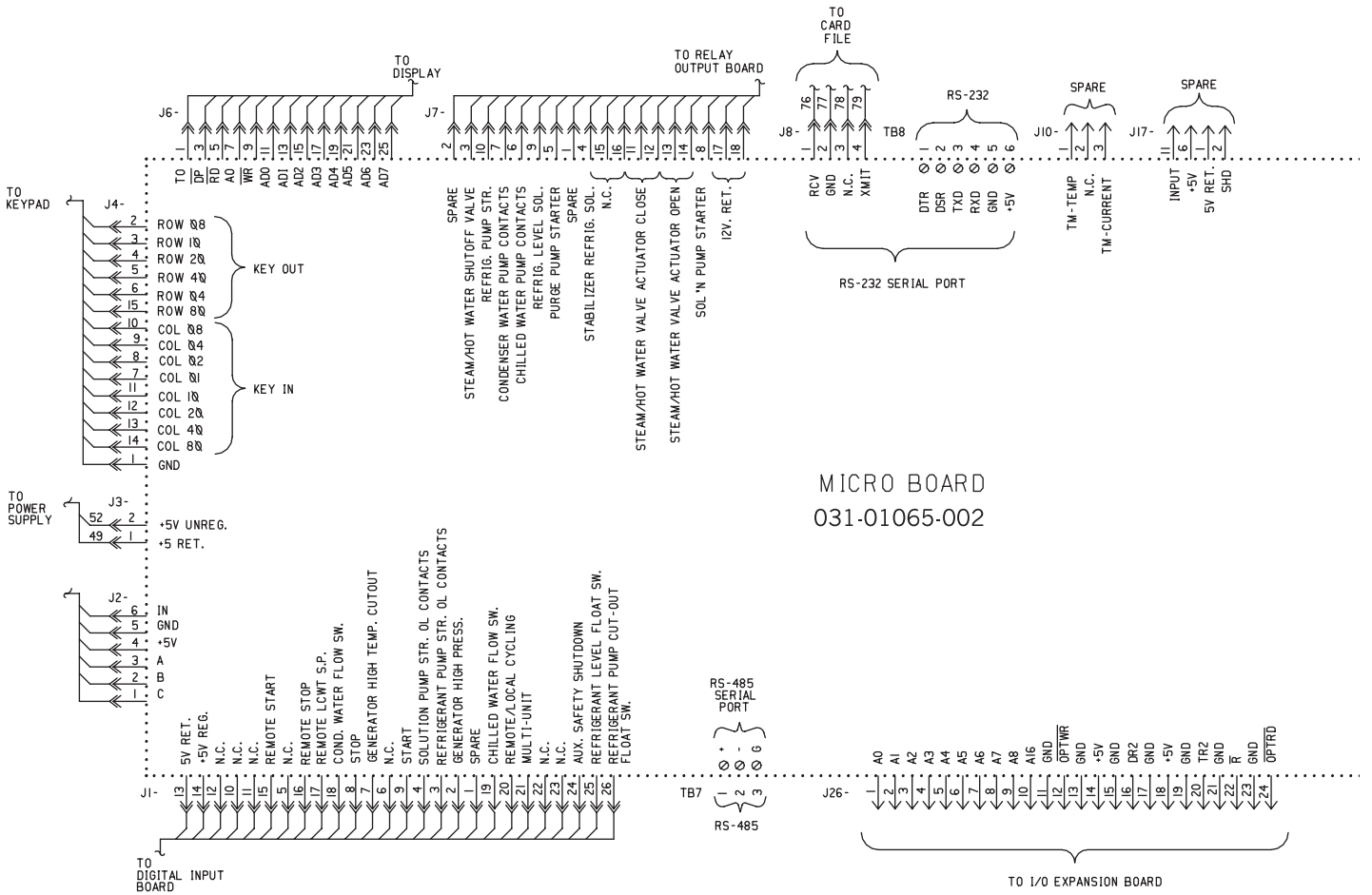

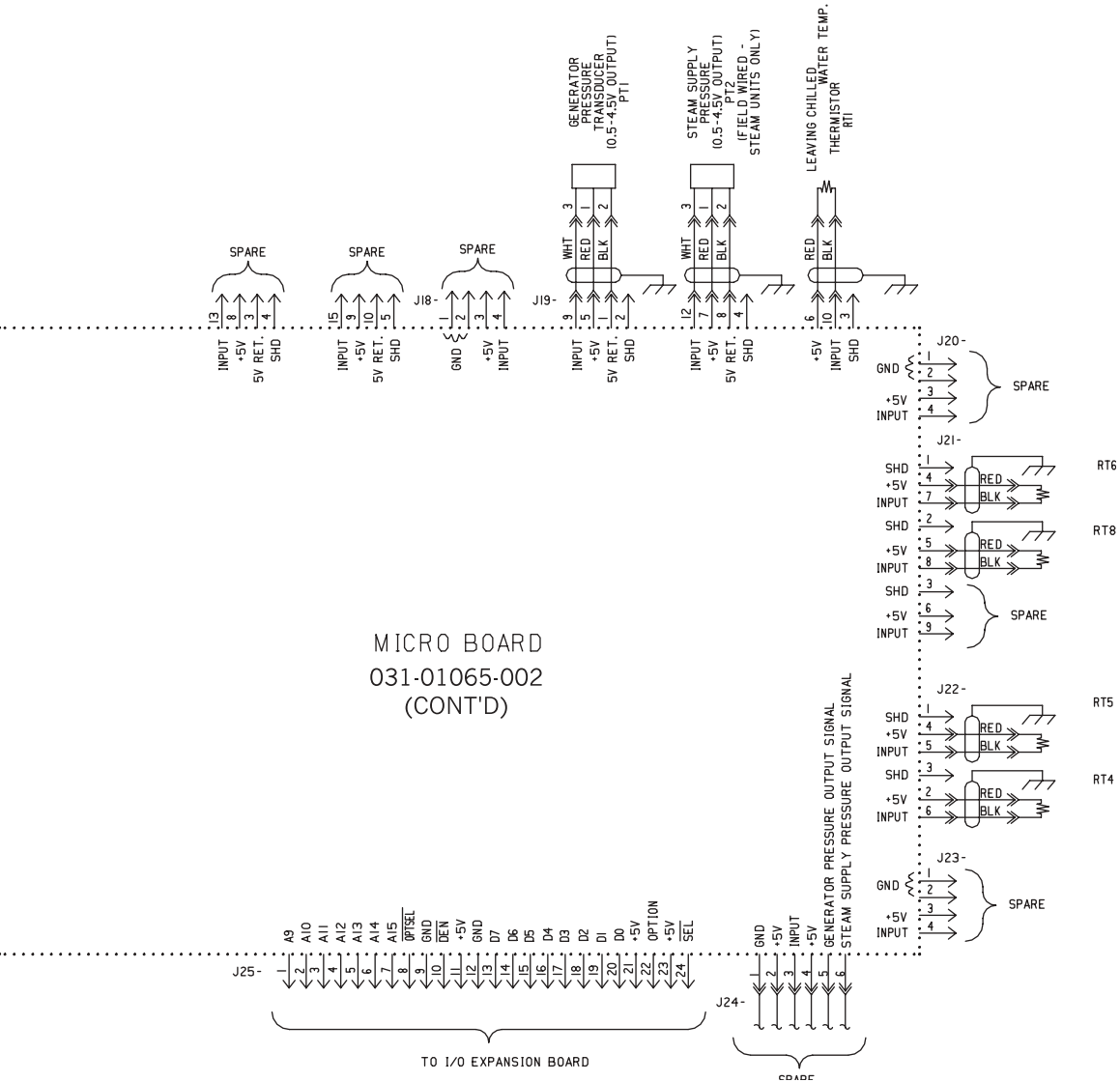

LD07854

This page intentionally left blank.

MICROCOMPUTER CONTROL CENTER (50 HZ)

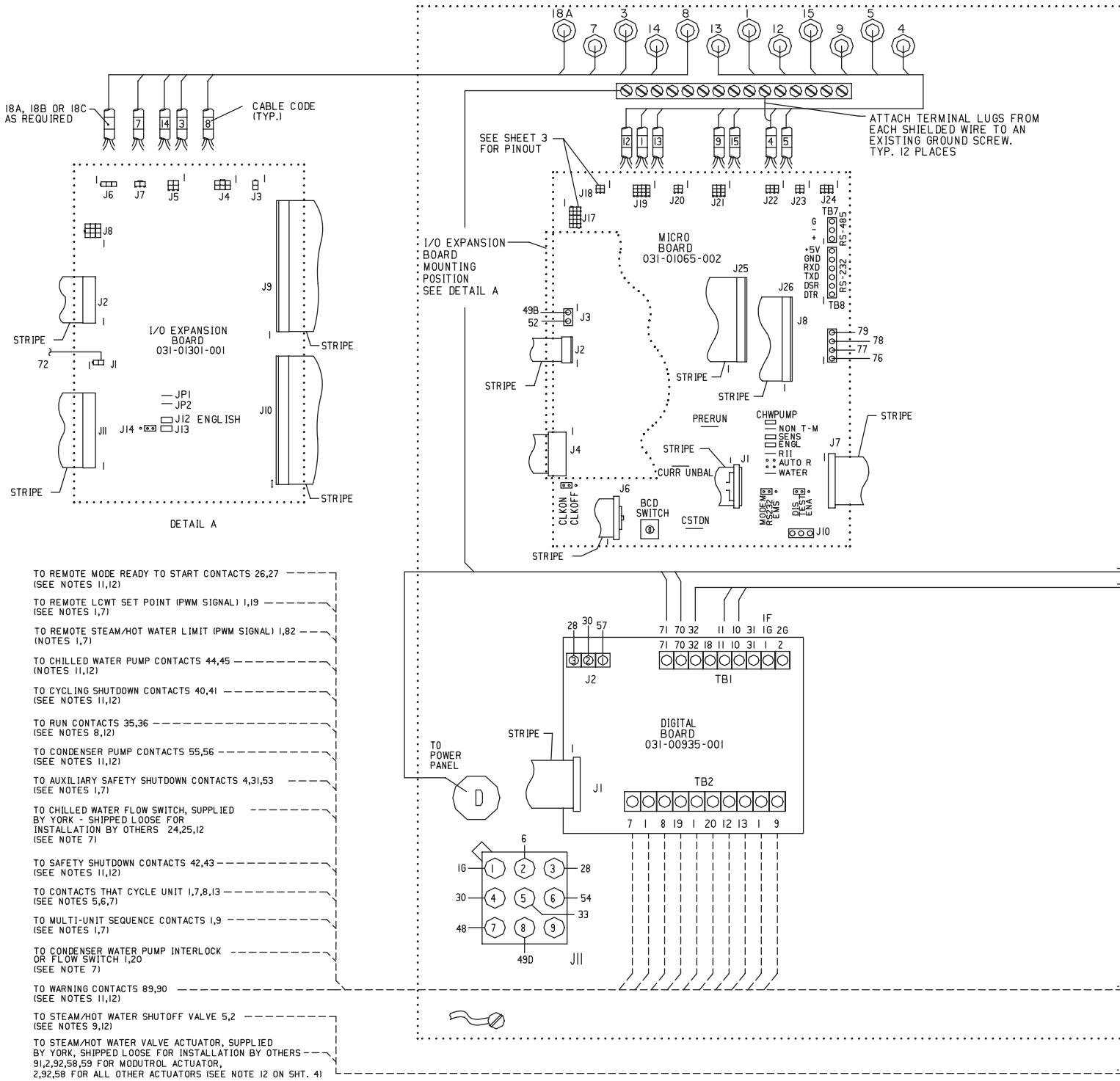

MICROCOMPUTER CONTROL CENTER

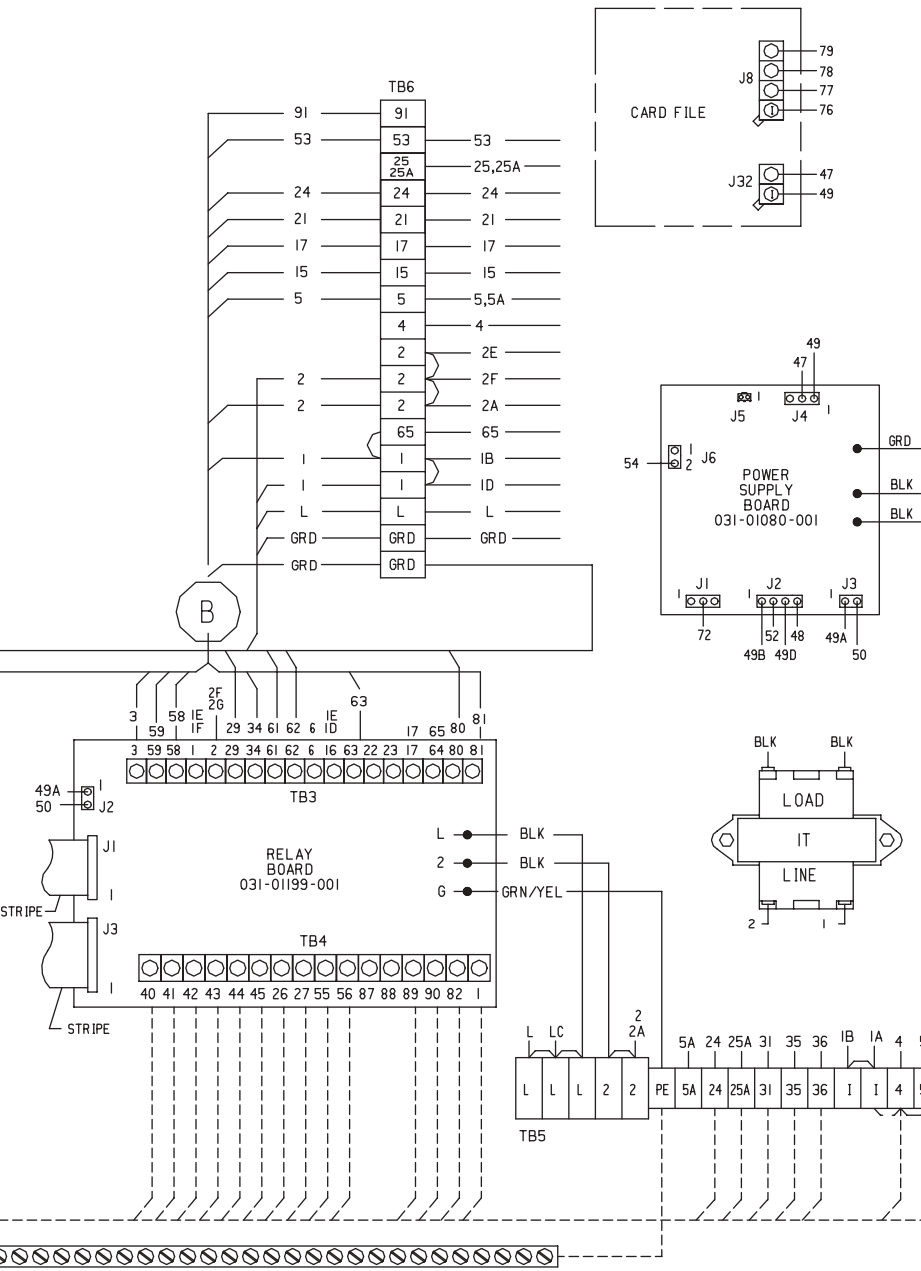

DOOR OPEN (REAR SIDE OF DOOR)

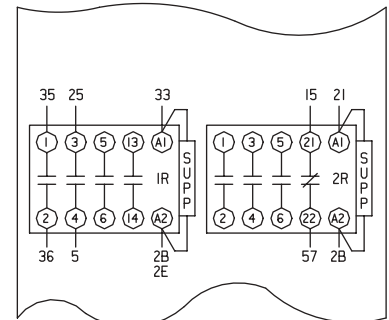
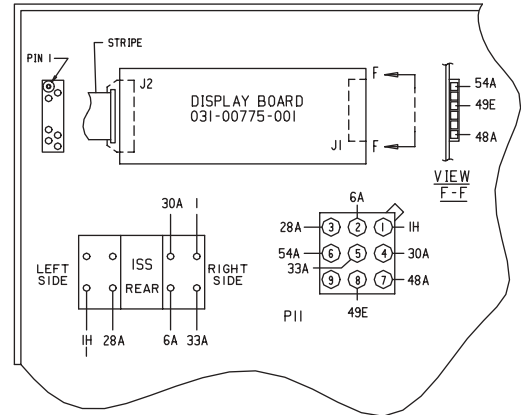

INSIDE VIEW OF RIGHT SIDE

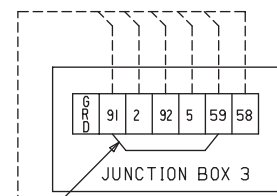

JUMPER MUST BE REMOVED WHEN THE MODUTROL ACTUATOR IS USED

LD07855

CONNECTION DIAGRAM (50 HZ)

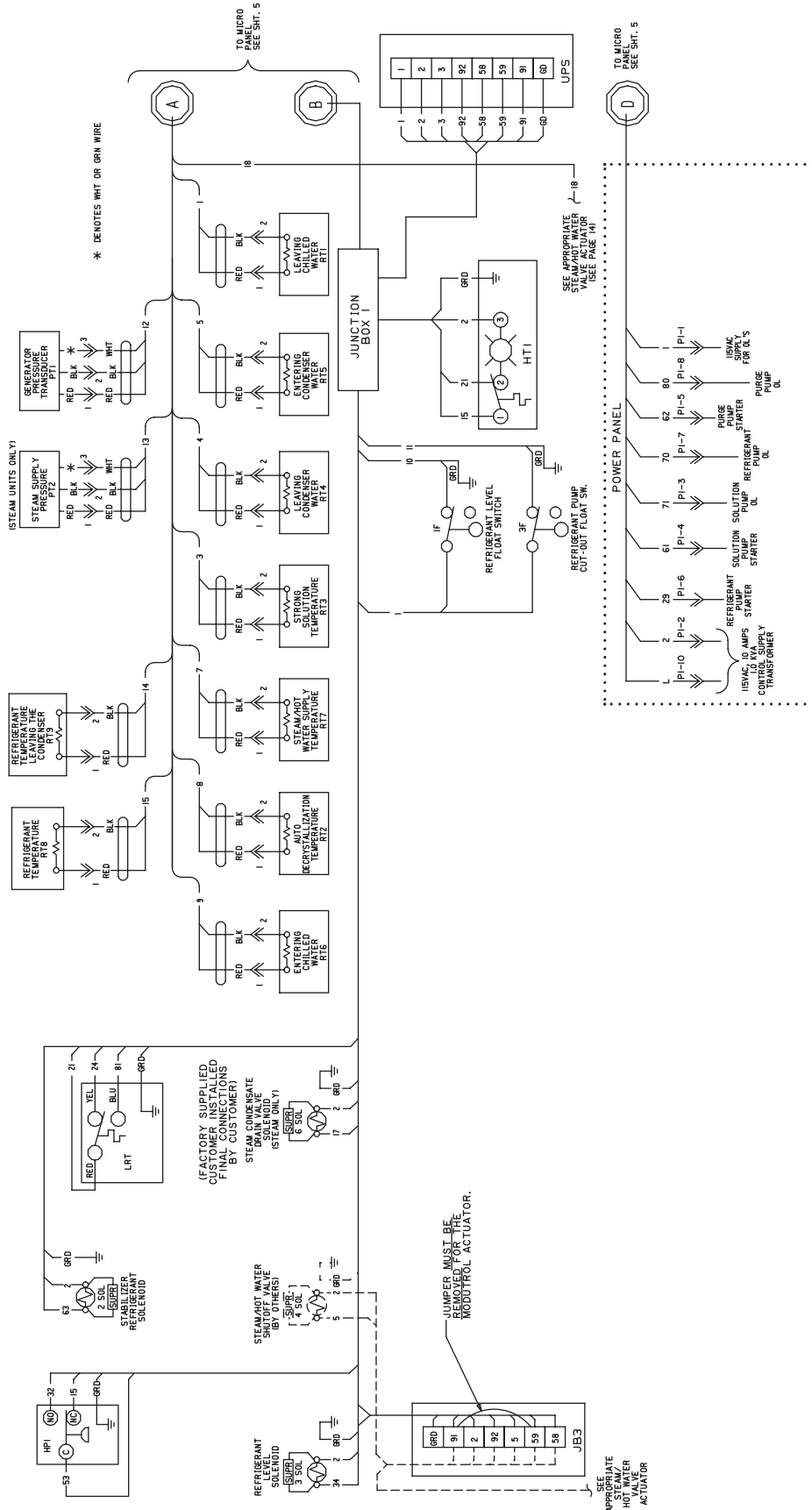

LD07856

INCOMING POWER / PUMP CONNECTIONS (50 HZ)

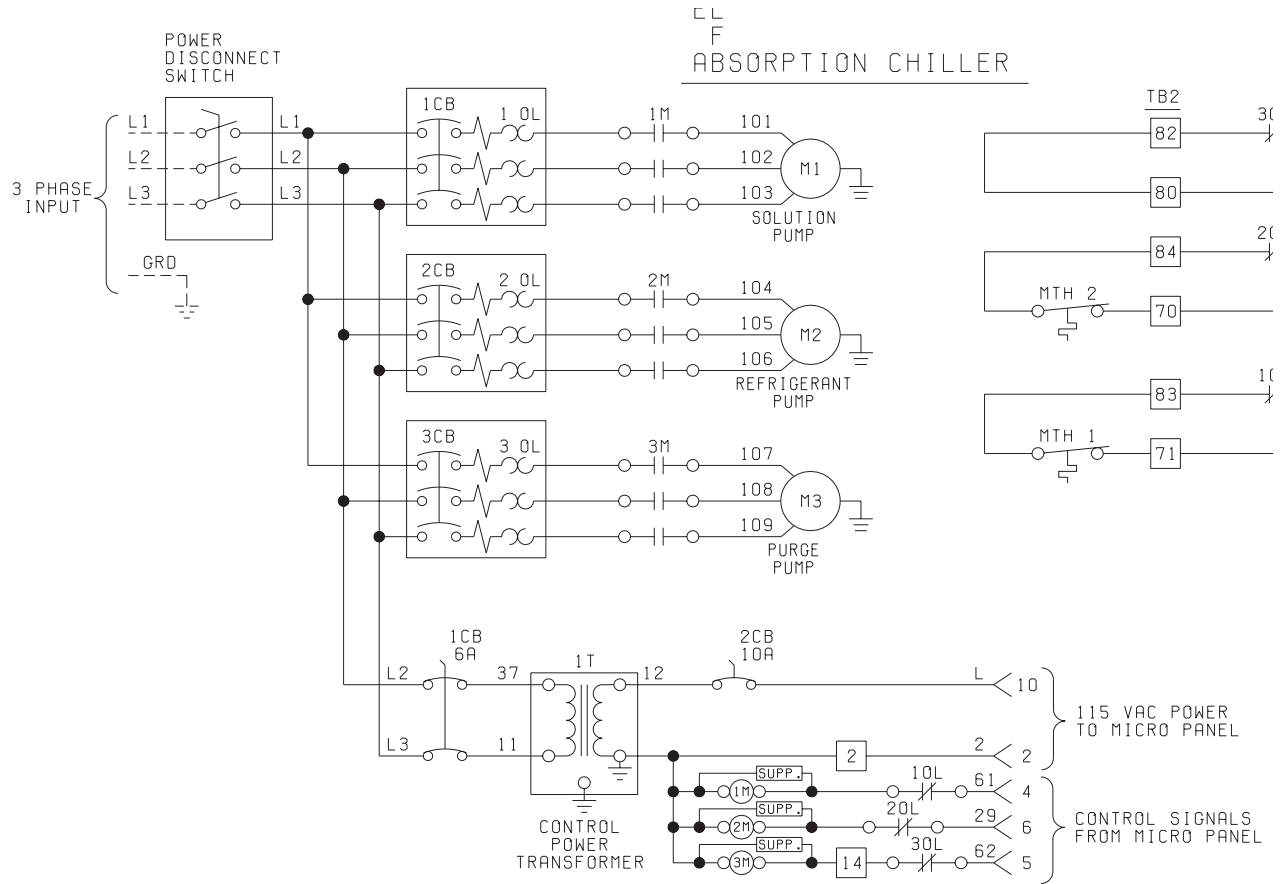

LD01568(D)

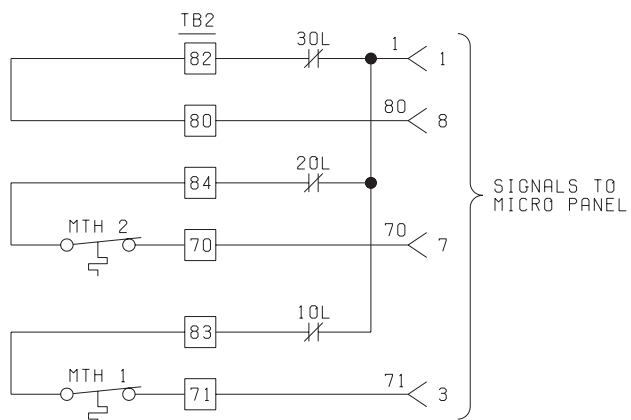

LD01568(D)

POWER PANEL WIRING DIAGRAM (50 HZ)

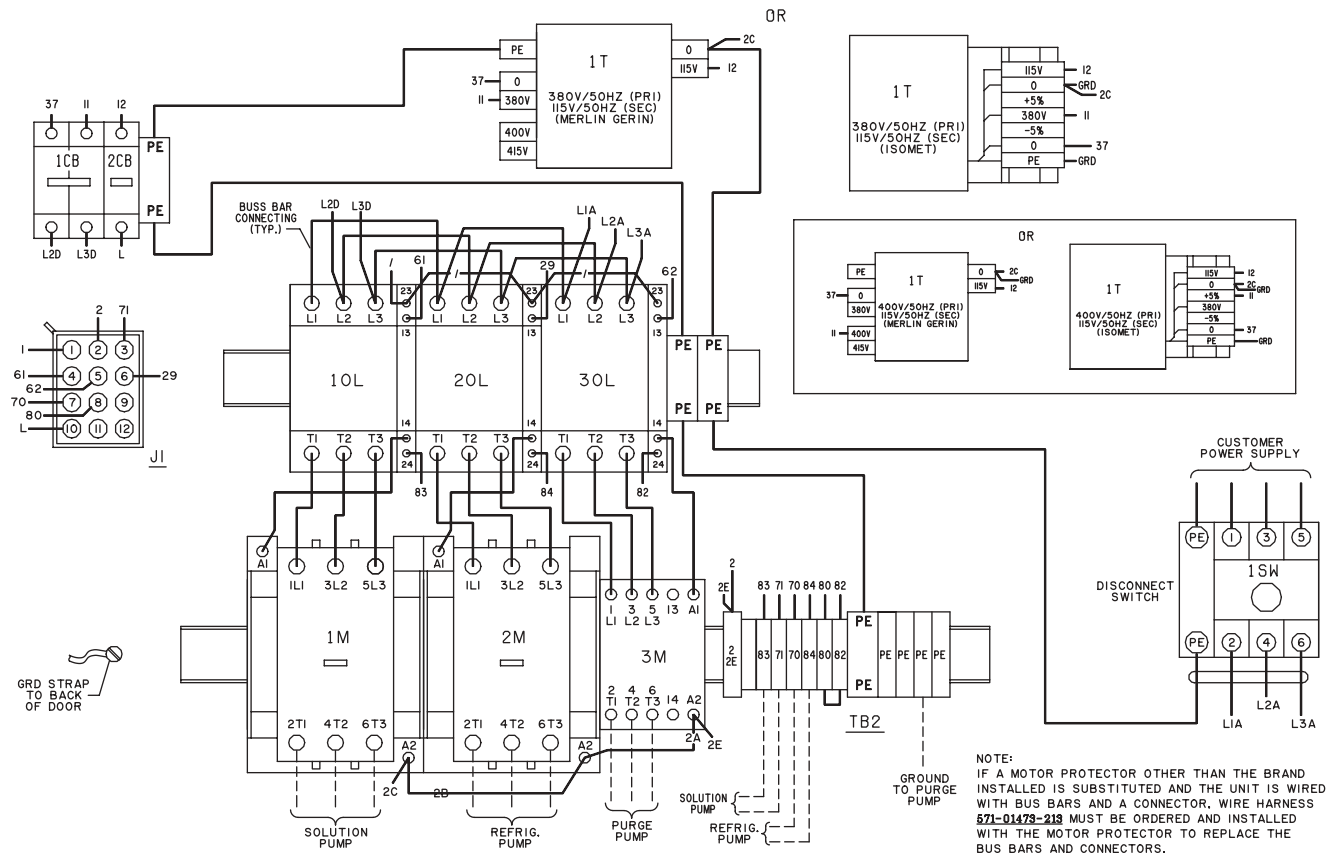

LD07858

NOTES FOR 60 AND 50 HZ

1. This wiring diagram describes the standard electronic control scheme. Refer to the power panel wiring diagram for additional information. For details of standard modifications, refer to product Form 155.16-PA1.
2. Field wiring to be in accordance with the National Electrical Code as well as all other applicable codes and specifications.
3. Numbers along the left side of diagram are line identification numbers. The numbers along the right side indicate the line number location of relay contacts. An underlined contact location signifies a normally closed contact.
4. Main control panel Class 1 field wiring terminal connection points are indicated by numbers within a rectangle, i.e. **15**. Main control panel factory wiring terminals connection points are indicated by numbers within a triangle, i.e. **2**. Component terminal markings are indicated by numbers within a circle, i.e. **C1**. Numbers adjacent to circuit lines are the circuit identification numbers.
5. To cycle unit on and off automatically with contacts other than those shown, install a cycling device between terminals **1** & **13** (See note 7). If a cycling device is installed, jumper must be removed between terminals **1** & **13**.
6. To stop unit and not permit it to start again, install a stop device between terminals **1** & **8** (See note 7). A remote start-stop switch may be connected to terminals **1**, **7** & **8** (See note 7). Remote start-stop switch is operative only in the "REMOTE" operating mode.
7. Device contact rating to be 5 milliamperes at 115 volts A.C.
8. Contact rating is 5 amps resistive at 120 volts A.C. or 240 volts A.C.
9. Maximum allowable current draw is 1 amp holding, 10 amps inrush for 115VAC field-supplied steam shutoff valve.
10. The factory supplied jumper between **4** & **53** must be removed when safety devices are used.
11. Contact rating is 5 amps resistive at 250 volts A.C. & 30 volts D.C., 2 amp inductive (0.4 PF) at 250 volts A.C. & 30 volts D.C.
12. Each 115VAC field-connected inductive load: i.e., relay coil, motor starter coil, etc. shall have a transient suppressor wired in parallel with its coil, physically located at the coil. Spare transient suppressors and control circuit fuse are supplied in a bag attached to the fuseholder.

