 PRODUCT DRAWING	Supersedes: 155.17-PA1 (396) Form 155.17-PA1 (1296) FIELD CONTROL MODIFICATIONS DIAGRAM FOR MILLENNIUM™ YPC CONTROL CENTER	
YORK INTERNATIONAL CORPORATION P.O. Box 1592, York, PA 17405		
CONTRACTOR _____ ORDER NO. _____ YORK CONTRACT NO. _____ YORK ORDER NO. _____	PURCHASER _____ JOB NAME _____ LOCATION _____ ENGINEER _____	
<input type="checkbox"/> REFERENCE DATE _____	<input type="checkbox"/> APPROVAL DATE _____	<input type="checkbox"/> CONSTRUCTION DATE _____

For use with YORK Millennium Two Stage Absorption Chillers:

Applies to all Direct-Fired and Steam-Fired Models

JOB DATA:

YPC MODEL NO. _____	YPC MODEL NO. _____
NO. OF UNITS _____	NO OF UNITS _____

SEE FIGURES: _____

INCLUDED BY YORK FOR FIELD INSTALLATION (BY OTHERS) ARE:

	YES	NO	Per Unit
Millennium SEQUENCE COMMANDER II when available, Part No. 466-61597T	<input type="checkbox"/>	<input type="checkbox"/>	_____
Remote Steam Limit Setpoint Card, Part No. 031-00814-000 (Steam Units Only)	<input type="checkbox"/>	<input type="checkbox"/>	_____
Remote Temperature Control Point Reset Card, Part No. 031-00814-000	<input type="checkbox"/>	<input type="checkbox"/>	_____
Card File, Part No. 031-00827-000	<input type="checkbox"/>	<input type="checkbox"/>	_____
YORK Remote Chiller Communications (See Instructions Form 450.00-NSU8.1)	<input type="checkbox"/>	<input type="checkbox"/>	_____
_____	<input type="checkbox"/>	<input type="checkbox"/>	_____
_____	<input type="checkbox"/>	<input type="checkbox"/>	_____
_____	<input type="checkbox"/>	<input type="checkbox"/>	_____

ENERGY MANAGEMENT SYSTEMS

The Millennium Control Center is designed to function as an integral component of the YORK Millennium YPC Two-Stage Absorption Chiller/Heater. All of the data contained in the Millennium Chiller Control Center is shared with the YORK Direct Digital Controllers via the single twisted-pair YorkTalk Bus. All temperatures, pressures, safety alarms and cycling conditions are available to the Direct Digital Controllers for integrated plant control, data logging, and local and remote display of operator information. The YorkTalk Bus communication of operator information. The YorkTalk Bus communication interface also allows the Direct Digital Controllers to issue commands to the Millennium Control Center to set temperature setpoints and start or stop the unit.

The Millennium Control Center also provides a limited interface to other Energy Management Systems (EMS). The Millennium Control Center includes unit status contacts, provisions for remote temperature setpoint reset and starting and stopping of the unit.

Five sets of unit status contacts are factory furnished through a field wiring terminal board in the Control Center. Each set of contacts are single pole, normally open, rated at 5 amperes resistive at 240 VAC. Status contacts are provided for unit:

- Warning - See Fig. H
- Remote Mode Ready to Start - See Fig. A
- Cycling Shutdown - See Fig. B
- Safety Shutdown - See Fig. C
- Run (System Operating) - See Fig. D

Three sets of inputs are available to the EMS, allowing for remote control of YPC unit operation. Input device contact rating shall be 5 milliamperes at 115VAC. Field wiring terminal board (TB2) in the Control Center permits connection for the following operation:

- Remote Stop Contacts - See Fig. E
- Remote Start Contacts - See Fig. E
- Remote / Local Cycling Devices - See Fig. F

The YPC unit should not be cycled frequently by the Energy Management System. Instead, it is possible to reduce the energy input indirectly or directly by the following methods:

1. Application of Sequence Control Kit, so only one

unit is running when a single unit can carry the cooling load - See Fig. J.

2. When multiple YPC installations are controlled by an EMS, remote start and stop contacts are available to start and stop each chiller per Fig. E. Contact rating shall be 5 milliamperes at 115 VAC.
3. The Control Center has a programmable time clock function as a standard feature with holiday capacity. This offers one preset automatic Start-Stop per day on a seven day calendar basis with the ability to program a single additional holiday start and stop time up to a week in advance. Chilled water pump control contacts (see Note 13) are also provided, allowing for efficient automatic operation of the chilled water pump to reduce energy. Two chilled water pump operating modes are available via the LWT PUMP programming jumper (J54) on the Micro Board. With jumper J54 installed, the chilled water pump operates for 30 seconds prior to unit start, during unit operation, dilution cycle, and LWT cycling shutdowns. With jumper J54 removed, the chilled water pump operates as above plus it operates during MULTI-UNIT and REMOTE/LOCAL cycling shutdowns.
4. Reduce the energy input by raising the leaving chilled liquid temperature or lowering the leaving hot water temperature through remote temperature control setpoint in the "remote" operating mode. When remote temperature reset is accomplished by supplying a 1 to 11 second pulse-width modulated signal, refer to Fig. P. Through use of the remote temperature control setpoint option (at additional cost) card and card file, the leaving chilled liquid temperature may be reset via a 4 to 20 mA D.C. current signal, a 0 to 10 volt D.C. signal, or a single contact closure per Fig. W.
5. Steam or Fuel limiting of demand during pulldown may be accomplished by using the standard PULLDOWN DEMAND LIMIT function provided in the Millennium Control Center. The "Pulldown Demand Limit" key can be programmed to limit steam or fuel input from 20 to 100% for steam units or 30 or 100% for fuel units in ramp fashion, for 1 to 255 minutes following each unit start. For more details, refer to Millennium Control Center Instructions, Form 155.17-O2.

LIST OF FIGURES

FIG. A	-	REMOTE MODE READY TO START CONTACTS	4
FIG. B	-	CYCLING SHUTDOWN CONTACTS	4
FIG. C	-	SAFETY SHUTDOWN CONTACTS	5
FIG. D	-	RUN CONTACTS	5
FIG. E	-	REMOTE START-STOP CONTACTS FROM ENERGY MANAGEMENT SYSTEM	6
FIG. F	-	REMOTE/LOCAL CYCLING DEVICES	6
FIG. G	-	MULTI-UNIT SEQUENCE	7
FIG. H	-	WARNING CONTACTS	7
FIG. J	-	TWO UNIT SEQUENCE CONTROL (KIT)	8
FIG. K	-	MULTIPLE UNITS (TWO) - SERIES OPERATION	8
FIG. L	-	MULTIPLE UNITS (TWO) - PARALLEL OPERATION - INDIVIDUAL PUMPS	9
FIG. M	-	MULTIPLE UNITS (TWO) - PARALLEL OPERATION - SINGLE CHILLED WATER PUMP	9
FIG. N	-	SAFETY DEVICES (AUXILIARY SAFETY SHUTDOWN)	9
FIG. P	-	REMOTE LEAVING CHILLED OR HOT (GAS/OIL-FIRED UNITS ONLY) WATER TEMPERATURE SETPOINT WITH PWM SIGNAL	10
FIG. Q	-	REMOTE STEAM LIMIT SETPOINT WITH PWM SIGNAL (STEAM UNITS ONLY)	10
FIG. R	-	MICROBOARD JUMPERS FOR AUTO/MANUAL RESTART AFTER POWER FAILURE OR ENGLISH/METRIC DISPLAY UNITS	11
FIG. U	-	CARD FILE	12
FIG. V	-	REMOTE STEAM LIMIT - OPTION CARD #1 (STEAM UNITS ONLY)	13-14
FIG. W	-	REMOTE LEAVING CHILLED OR HOT (GAS/OIL-FIRED UNITS ONLY) WATER TEMPERATURE SETPOINT OPTION CARD #2	15-16
FIG. X	-	REMOTE START-STOP PUSH-BUTTON STATION	17
FIG. Y	-	EXTERNAL SIGNAL FOR CHILLER/HEATER UNIT SAFETY SHUTDOWN	17
FIG. AA	-	RUN CONTACTS/REMOTE RUN LIGHT AND SHUTDOWN INDICATOR PLUS EMS	18
FIG. BB	-	BACKUP GENERATOR TRANSFER	19

TO ENERGY MANAGEMENT SYSTEM
FROM YPC UNIT

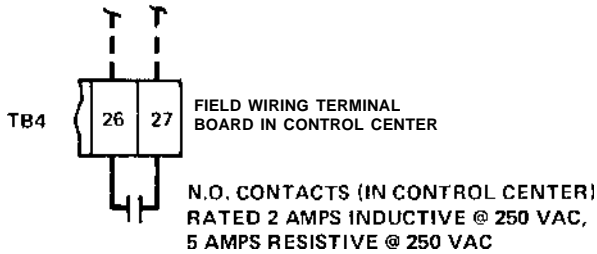

LD00855

FIG. A – REMOTE MODE READY TO START CONTACTS

FIG. A – REMOTE MODE READY TO START CONTACTS - When closed, these contacts signify the following: (1) The Millennium Control Center is in “remote” operating mode, allowing for energy management system or remote start/stop control (Fig. E); (2) All unit safety cutout controls are in the normal position, so they will allow the YPC unit to start; (3) All unit cycling cutout controls are in the normal position, so they will allow the Millennium unit to start; (4) The Control Center “unit” switch is in the “run” position. A closure of the Remote Mode Ready to Start Contacts then signifies that the Millennium unit shall start when the Energy Management System Maintains the Remote Stop contact (Fig. E) open and momentarily closes the Remote Start Contact (Fig. E). When the Remote Mode Ready to Start Contacts close, the Control Center will display the following message “SYSTEM READY TO START.”

TO ENERGY MANAGEMENT SYSTEM
FROM YPC UNIT

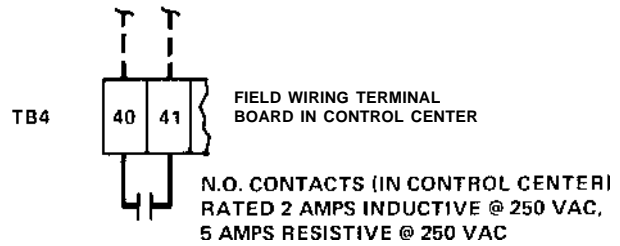

LD00856

FIG. B – CYCLING SHUTDOWN CONTACTS

FIG. B – CYCLING SHUTDOWN CONTACTS - When closed, these contacts signify that the unit is not permitted to start due to one or more of the following occurrences: (1) The leaving chilled water temperature has dropped more than 3°F below setpoint or a minimum of 40°F (in cooling mode) or the leaving hot water temperature has risen more than 5°F above setpoint (in heating mode); (2) The steam valve actuator is loaded greater than 10% (steam units only); (3) The condenser water pump interlock or flow switch contacts are open (in cooling mode) (see “Field Connections” wiring diagram, Form 155.17-W1 for gas/oil-fired units or Form 155.19-W1 for steam units); the Remote/Local Cycling Devices are open - see Fig. F; the Multi-Unit Sequence Contacts are open - see Fig. G; (6) The Micro Board 5 VDC supply is less than 4.75 VDC (Power Failure); a 115VAC supply power failure occurred when the unit was off with the “Auto Restart After Power Failure” programming jumper installed on the Micro Board - see Fig. R; or (11) the hot water flow switch is open (heating mode only). Upon closure of all contacts above, the unit will automatically restart. When the Cycling Shutdown Contacts are closed, the Control Center will display the following message: “SYSTEM SHUTDOWN - PRESS STATUS”; upon pressing the “status” key, the message displayed consists of the day and time of shutdown plus the cause of the shutdown.

TO ENERGY MANAGEMENT SYSTEM
FROM YPC UNIT

FIG. C – SAFETY SHUTDOWN CONTACTS

LD00857

FIG. C – SAFETY SHUTDOWN CONTACTS - When closed, these contacts signify that the unit is not permitted to start due to one or more of the following safety controls: (1) Solution or refrigerant pump overloads or thermal switches tripped/open (cooling mode only); (2) Low refrigerant temperature cutout at 39.1°F (cooling mode only); (3) First stage generator high pressure cutout at 13.73 PSIA (analog backup at 15.00 PSIA); (4) First stage generator high temperature cutout at 330°F (analog backup at 337°F); first stage generator low solution level switch cutout, (gas/oil-fired units only) (5) Burner alarm indicator contacts open (gas/oil-fired units only); (6) Power Failure (when the “Auto Restart After Power Failure” jumper is removed from the Micro Board - see Fig. R; (7) Chilled water flow switch open (in cooling mode); (8) “Burner on” contacts open for 10 seconds continuously during unit run (or after a 180 second bypass during the start sequence); (9) Following a power failure, if the solution dilution temperature is less than 136°F when power is restored and the unit did not complete its previous dilution cycle, check the levels in the absorber and generator; (10) If, after a shutdown as described in item (1), when the solution or refrigerant pump overloads or thermal switches reclose, if the solution dilution temperature is less than 136°F, check the levels in the absorber and generator; (11) When the low refrigerant temperature cutout switch recloses or the refrigerant temperature sensor temperature rises to 44°F (whichever device caused the shutdown), if the solution dilution temperature is less than 136°F, check the levels in the absorber and generator; (12) If the chilled water flow switch recloses after shutdown as described in item (7) and the solution dilution temperature is below 136°F, check the levels in the absorber and generator. In items (9), (10), (11), and (12) after the levels are properly adjusted, the unit must be manually reset by pressing the “warning reset” key in “service” mode.

When all safety controls are satisfied, and the Control Center “unit” switch has been placed in the “stop/reset” position and then in the “run” position, the unit may be restarted, if the control center is in “remote” mode, via the Remote Start Contacts (Fig. E); or if the control center is in “local” mode the unit may be started by pressing the keypad-mounted “unit” switch to the “start” position.

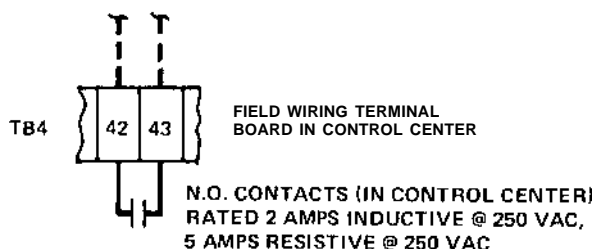
A closure of the Safety Contacts means that an operator must manually reset the unit. When the Safety Shutdown Contacts are closed, the Millennium Control Center will display the following message: “SYSTEM SHUTDOWN - PRESS STATUS.” Upon pressing “status” key, the status message consists of the day and time of shutdown plus cause of shutdown. Safety Shutdown Contacts function in all operating modes - local, remote, program, and service.

TO ENERGY MANAGEMENT SYSTEM
FROM YPC UNIT

FIG. D – RUN CONTACTS

LD00858

FIG. D – RUN CONTACTS - When closed, these contacts signify that the unit is operating. The Control Center will display:

- (1) “SYSTEM RUN - LEAVING TEMP. CONTROL” - Message displayed while the unit is running; indicating that the capacity control is being controlled by the leaving chilled water temperature setpoint (in cooling mode) or the leaving hot water temperature setpoint (in heating mode.)
- (2) “SYSTEM RUN - MAXIMUM COOLING” (in cooling mode) or “SYSTEM RUN - MAXIMUM HEATING” (in heating mode) - The message is displayed while the Millennium unit is running. It indicates that the unit is inhibiting loading due to its design operating limits controlled by the “MAXIMUM LOAD - Cooling=89%, HEATING=100%” setting. The actual limit is programmable from 50 to 100% individually for cooling and heating. The values for a specific unit are typically different and are dependent upon the specified operating conditions and unit design.

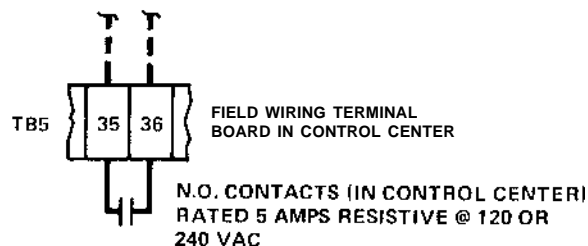
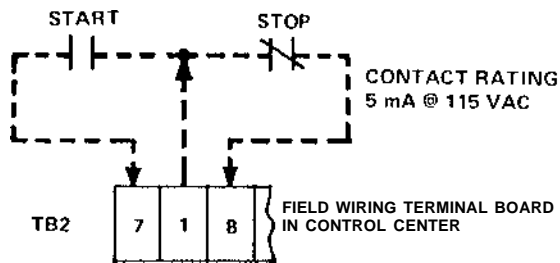

LD00859

FIG. E - REMOTE START-STOP CONTACTS FROM ENERGY MANAGEMENT SYSTEM

FIG. E - REMOTE START AND STOP CONTACTS FROM ENERGY MANAGEMENT SYSTEM -When the Control Center is in the “remote” operating mode and the “unit” switch is in the “run” position, with the Remote Stop Contacts open, and the Remote Mode Ready to Start Contacts closed (Fig. A), the Millennium unit will start via a momentary closure of the Remote Start Contacts. A subsequent closure of the Energy Management System Remote Stop Contacts causes the unit to shut-down. The Control Center will display the following message: “SYSTEM SHUTDOWN - PRESS STATUS”. Upon pressing “status” key “REMOTE STOP” message will be displayed when the Energy Management System Remote Stop Contacts has commanded the unit to shut-down.

When terminals 7 , 1 and 8 on terminal board TB2 are not connected to an Energy Management System, they may be connected to a Remote Start-Stop station (see Fig.E).

Note – Even when the unit is applied with Remote Start-Stop (when the Control Center is in the “remote operating” mode), an EMERGENCY STOP by an operator or others can STOP the unit from the Control Center and prevent the unit from restarting. However, the operator cannot locally start the unit using “unit” start switch, when the Control Center is in the “remote” operating mode.

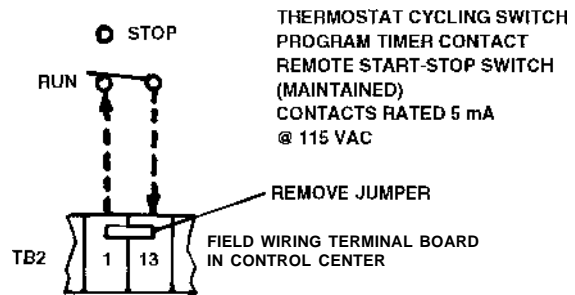

LD00860

FIG. F – REMOTE/LOCAL CYCLING DEVICES

FIG. F – REMOTE/LOCAL CYCLING DEVICES -The closure of an automatic reset device across this input will permit the unit to operate in all operating modes. Conversely, an opening of the device contacts will inhibit the unit from operating; the Control Center will then display the following message: “SYSTEM SHUTDOWN - PRESS STATUS”. Upon pressing “status” key, the status message will read day and time of shutdown; “DAY XX:XX AM - SYSTEM CYCLING - AUTO START.”

Note – The Control Center contains a seven day time clock to select daily schedule Start-Stop times (Sunday through Saturday including one or more holidays in week) up to one full week at a time. So automatic start and stop of the unit on a daily basis, at predetermined times, can be programmed as a standard feature; an additional program timer is not required for this function.

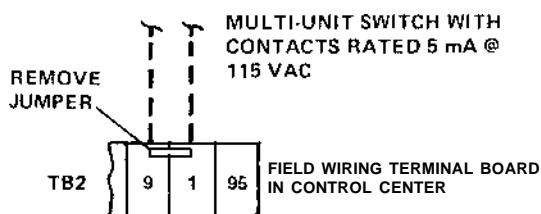

LD00861

FIG. G – MULTI-UNIT SEQUENCE

FIG. G – MULTI-UNIT SEQUENCE - For a multiple unit installation application, the Sequence Commander II may be used to sequence 2 to 8 units. The sequencing is accomplished via the YorkTalk communications bus using a single twisted-pair of wires to each chiller unit. When a Control Center is commanded to stop, the following message is displayed: "SYSTEM SHUTDOWN - PRESS STATUS." Upon pressing the "status" key, the message will read day and time of shutdown: "DAY XX:XX AM - REMOTE STOP." Refer to 450.10-N2 for more details.

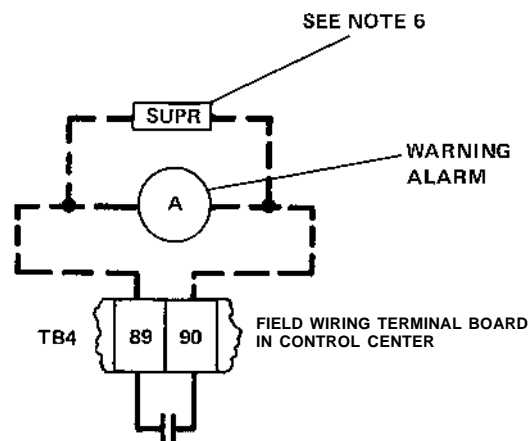

WARNING N.O. CONTACTS (IN CONTROL CENTER) RATED 2 AMPS INDUCTIVE @ 250 VAC, 5 AMPS RESISTIVE @ 250 VAC.

LD00862

FIG. H – WARNING CONTACTS

FIG. H – WARNING CONTACTS - The warning contacts may be employed to energize a local or remote warning alarm (by others). When one or more of the warning thresholds are exceeded and the unit is operating, the normally open warning contacts close to sound the alarm (by others). When the alarm (by others) sounds, it is indicative of one or more of the following warning conditions (which are displayed by pressing the "status" key on the Control Center): low refrigerant temperature (which inhibits unit loading); first stage generator high pressure override (which limits unit loading to 30% max.); first stage generator high temperature override (which limits unit loading to 30% max.); return condenser water temperature less than (<) 68°F (or <58°F for optional low condenser water temperature kit) after a 30 minute bypass at unit start; entering condenser water temperature >XX°F (which limits unit loading to 60% max.) after a 30 minute bypass at unit start (the limiting temperature is programmable from 75 to 95°F); purge pump overloads open; purge pump failure (optional automatic purge only) (if the purge pump pressure is greater than or equal to (\geq) 1.35 PSIA while the pump is running); purge transducer failure (optional automatic purge only) (if either purge tank or purge pump pressure is out of range low for 25 seconds continuously); excess purge, if 6 or more automatic purge cycles occur within 7 days (units with the optional automatic purge only); faulty solution dilution temperature sensor (for reading \leq 91°F for 1 minute continuously following a 30 minute bypass at unit start). If any of the warning thresholds are exceeded, the unit continues to run and the warning alarm, if connected (by others), may be silenced anytime by pressing the "warning reset" key. The displayed warning message may be cleared only when (1) the warning reset threshold has been previously reached and (2) by pressing the "warning reset" key in service mode.

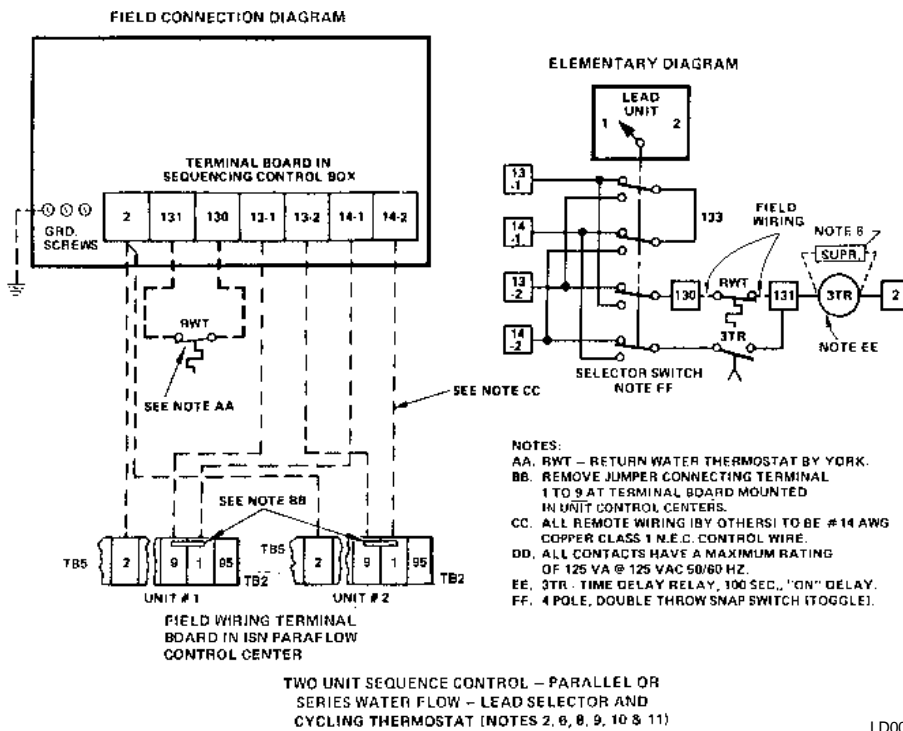

LD00863

FIG. J – TWO UNIT SEQUENCE CONTROL (COOLING APPLICATION ONLY)

FIG. J – TWO UNIT SEQUENCE CONTROL - Provides that cycling thermostat RWT will automatically cycle either #1 or #2 unit. Timer 3TR is an additional feature which prevents simultaneous starting of lead and lag unit following a power failure and eliminates nuisance starting of lead unit due to periodic fluctuations in temperature. For two unit sequence control kit, order YORK accessory Kit No. 466-61597T for controls as specified

with NEMA I enclosure. See Form 150.40-NM2.2 for Installation and Operation Instructions. RWT has 20°F to 80°F range with adjustable differential of 3-1/2 to 14°F; 6 ft. of capillary with 3/8" x 5" bulb and 1/2" NPT brass well (maximum liquid DWP 300 PSIG). The thermostat is drawn to indicate its operation closes on reset. A 1/2" pipe coupling is the return chilled water line from the building must be furnished (by others) for RWT control well.

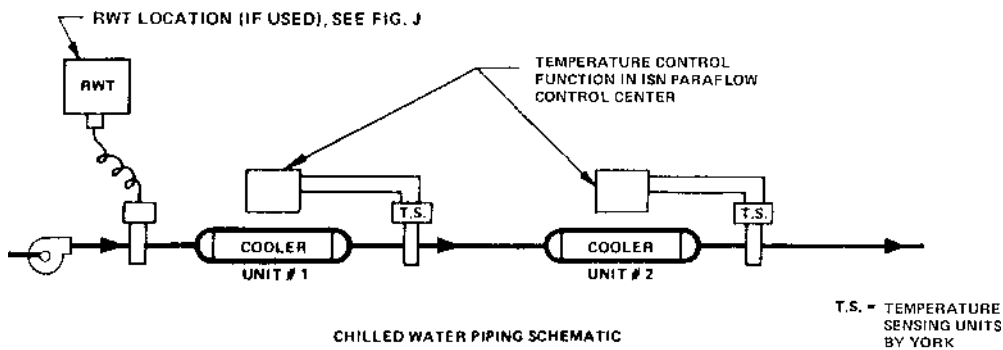

LD00864

FIG. K – MULTIPLE UNITS (TWO) - SERIES OPERATION (NOTES 8 & 11) (COOLING APPLICATION ONLY)

FIG. K – MULTIPLE UNITS (TWO) - SERIES OPERATION - The supply chilled water temperature to the building is normally determined by the “chilled water temp.” setpoint for Unit #2. When lead selector position of sequence control kit (Fig. J) is Unit #1, the supply chilled

water temperature to the building will be the temperature control setpoint on Unit #1 Control Center. If a lower temperature is desired, reprogram the “chilled water temp.” setpoint for Unit #1.

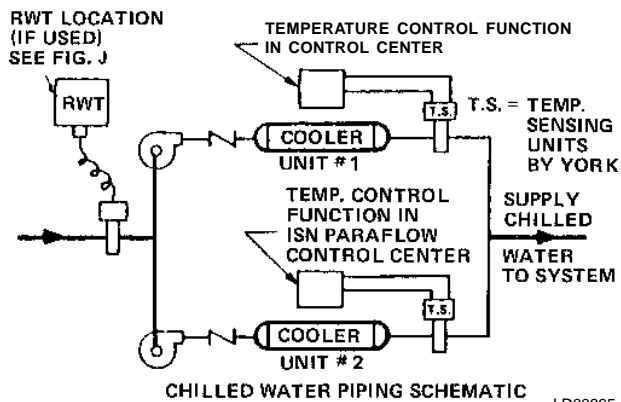

MULTIPLE UNITS - PARALLEL OPERATION:
 IN THIS ARRANGEMENT, THE INDIVIDUAL CHILLED WATER PUMP IS STOPPED WHEN THE ONE UNIT IS SHUT DOWN AT APPROXIMATELY 40% SYSTEM LOAD. LEAVING CHILLED WATER TEMPERATURE IS CONSTANT ($\pm 1/2^\circ\text{F}$) AT ALL LOADS. (NOTES 8 & 11)

FIG. L – MULTIPLE UNITS (TWO) - PARALLEL OPERATION - INDIVIDUAL UNIT PUMPS (COOLING APPLICATION ONLY)

FIG. L – MULTIPLE UNITS (TWO) - PARALLEL OPERATION - INDIVIDUAL UNIT PUMPS - The piping arrangement is the same as Fig. M, except that the chilled water pumps associated with each cooler (evaporator) are cycled on and off with the unit. This results in reduced chilled water flow rates whenever a single unit can handle the cooling load. Because no chilled water flows through the inoperative unit, the mixed water temperature peculiar to using a single pump is avoided. When one unit is cutout by the sequence control (Fig. J) the temperature of the supply chilled water does not change.

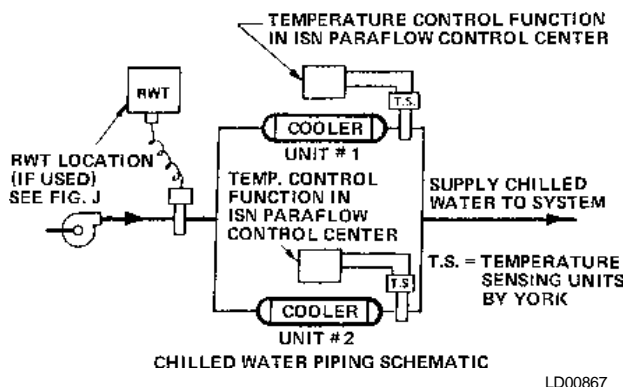

MULTIPLE UNITS - PARALLEL OPERATION:
 IN THIS ARRANGEMENT, WHEN ONE UNIT IS SHUT DOWN AT APPROXIMATELY 40% LOAD, THE CHILLED WATER TEMPERATURE SUPPLY TO THE SYSTEM RISES TO THE MIXED TEMPERATURE OF THE CHILLED WATER LEAVING BOTH UNITS, FOR ALL LOADS DOWN TO MINIMUM CAPACITY. LEAVING CHILLED WATER TEMPERATURE IS CONSTANT ($\pm 1/2^\circ\text{F}$) AS LONG AS BOTH UNITS ARE IN OPERATION. (NOTES 8 & 11)

FIG. M – MULTIPLE UNITS (TWO) - PARALLEL OPERATION - SINGLE CHILLED WATER PUMP (COOLING APPLICATION ONLY)

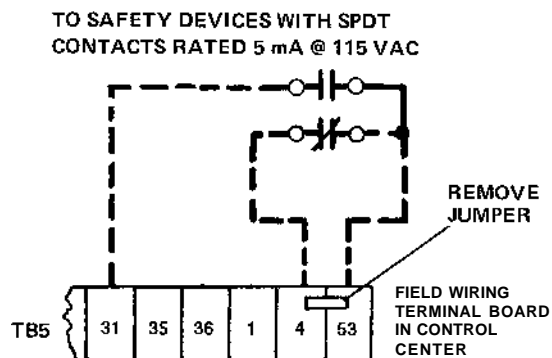

FIG. N – SAFETY DEVICES

FIG. N – SAFETY DEVICES - Terminals are available for connection of safety devices. An opening of the contacts causes the Control Center to display: "SYSTEM SHUTDOWN - PRESS STATUS." Upon pressing "status" key, the status message will read the day and time of shutdown, "DAY XX:XX AM - AUXILIARY SAFETY SHUTDOWN." To restart the unit, reset the external safety device that caused the shutdown. Then the unit can be restarted by pressing the "unit" switch to "stop/reset" and then to "start."

FIG. M – MULTIPLE UNITS (TWO) - PARALLEL OPERATION - SINGLE CHILLED WATER PUMP (COOLING APPLICATION ONLY) - For this piping arrangement, each unit's water sensor is located in its own leaving water nozzle. This produces a constant "mixed" chilled water temperature when both units are operating. When either unit is cycled off by the sequence control (Fig. J), mixed chilled water temperature will rise as a result of uncooled return water flowing through the inoperative unit. For individual unit chilled water piping, refer to Fig. L.

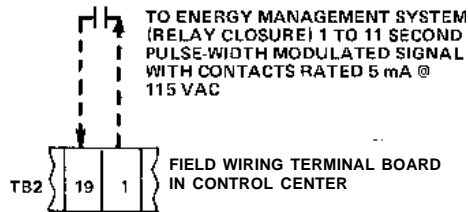

FIG. P – REMOTE LEAVING CHILLED OR HOT WATER TEMPERATURE SETPOINT WITH PWM SIGNAL (NOTE 14)

FIG. P – REMOTE LEAVING CHILLED OR HOT WATER TEMPERATURE SETPOINT WITH PWM SIGNAL

- The Control Center can be programmed via panel "remote reset temp. range" setpoint for a 10°F or 20°F leaving chilled or hot water temperature reset range. Then automatic remote temperature setpoint is accomplished by supplying (by others) a 1 to 11 second pulse-width modulated signal across terminals [1] and [19] on the digital input board (field wiring terminal board TB2) in the Control Center. The input signal will only be accepted when the Control Center is in the "remote" operating mode - see Fig. A. Millennium unit capacity control is from the leaving chilled or hot water temperature, providing the unit load is below the "maximum cooling or heating load" setpoint. A one second pulse corresponds to zero degree F offset and therefore at the programmed leaving chilled or hot water temperature setpoint. An eleven second pulse corresponds to maximum offset (10°F or 20°F as programmed) above the programmed chilled water (cooling mode) or below the hot water setpoint (heating mode) setpoint. The amount of offset from 1 to 11 seconds varies linearly with pulse-width. For example, a 3 second pulse applied (across terminals [1] and [19]) to the unit programmed for 45°F leaving chilled water temperature setpoint and 20°F "remote reset temp. range," the new setpoint would be:

Temp Offset -

$$\text{Deg. F offset} = \frac{(\text{pulse-width} - 1)(\text{remote reset temp. range})}{10}$$

$$\text{Deg. F offset} = \frac{(3-1)(20)}{10} = 4^\circ\text{F}$$

$$\text{Setpoint} = \text{keypad entered setpoint} + ^\circ\text{F offset}$$

Thus the new leaving chilled water temperature control point is 45°F + 4°F = 49°F.

The maximum rate at which the Control Center will accept reset pulses is one pulse each 60 seconds. If a seconds reset pulse is not received within 30 minutes of the first pulse, the temperature setpoint reverts to the base setpoint (with no offset).

For remote temperature setpoint via a 4 to 20 mA D.C. current signal, a 0 to 10 volt D.C. signal, or single contact closure, refer to Fig. W.

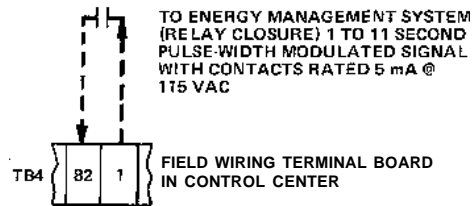

LD00869

FIG. Q – REMOTE STEAM LIMIT SETPOINT WITH PWM SIGNAL (STEAM UNITS ONLY)

FIG. Q – REMOTE STEAM LIMIT SETPOINT WITH PWM SIGNAL (STEAM UNITS ONLY)

Remote steam limit is accomplished by supplying (by others) a 1 to 11 second pulse-width modulated signal across terminals [1] and [82] on a digital input of the relay board (field wiring terminal board TB4) in the Control Center. The input signal will only be accepted when the Control Center is in the "remote" operating mode - see Fig. A. Unit capacity control is from the leaving chilled water temperature, providing the steam limit setpoint is satisfied. When the % steam valve opening exceeds the steam limit setpoint, it will override the temperature control system to reduce unit capacity. A one second pulse corresponds to 100% full load and an eleven second pulse corresponds to 20% of full load. The steam limit setpoint varied linearly from 100% to 20% as the pulse-width changes from 1 to 11 seconds. Since the lower limit of the steam valve is controlled by a mechanical limit switch (factory adjusted specifically for each unit), the minimum valve position during unit operation is generally 25-30%. For example, for a 5 second pulse applied across terminals [1] and [82] of TB4, the steam limit setpoint would be as follows:

Remote Steam Limit -

$$\text{Setpoint} = 100\% - (\text{pulse-width in seconds} - 1) 8\%$$

$$\text{Setpoint} = 100\% - (5 - 1) 8\% = 100\% - 32\% = 68\%$$

The maximum rate at which the Millennium Control Center will accept remote steam limit setpoint pulses is one pulse each 60 seconds.

Following a remote setpoint pulse, the steam limit setpoint changes to the value corresponding to the pulse-width. If a second reset pulse is not received within 30 minutes of the first pulse, the steam setpoint reverts to the programmed maximum load limit setpoint. If the Control Center "Pulldown Demand Limit" (standard available function) has been programmed and the unit was started and has run less than the Pulldown Demand Limit timer setting, then the unit will be steam limited by the lower of the Pulldown Demand Limit and remote steam limit. The Pulldown Demand Limit will automatically transfer control of steam limit function to "remote" at the end of its programmed timed cycle with the unit in "remote" mode.

On steam units only, Fig. Q can be applied in conjunction with Fig. P, thus providing the capability of remotely controlling both motor steam limit setting AND leaving chilled or hot water temperature simultaneously, if so desired.

For remote steam limit setpoint via a 4 to 20 mA D.C. current signal, a 0 to 10 volt D.C. signal, or a single contact closure, refer to Fig. V.

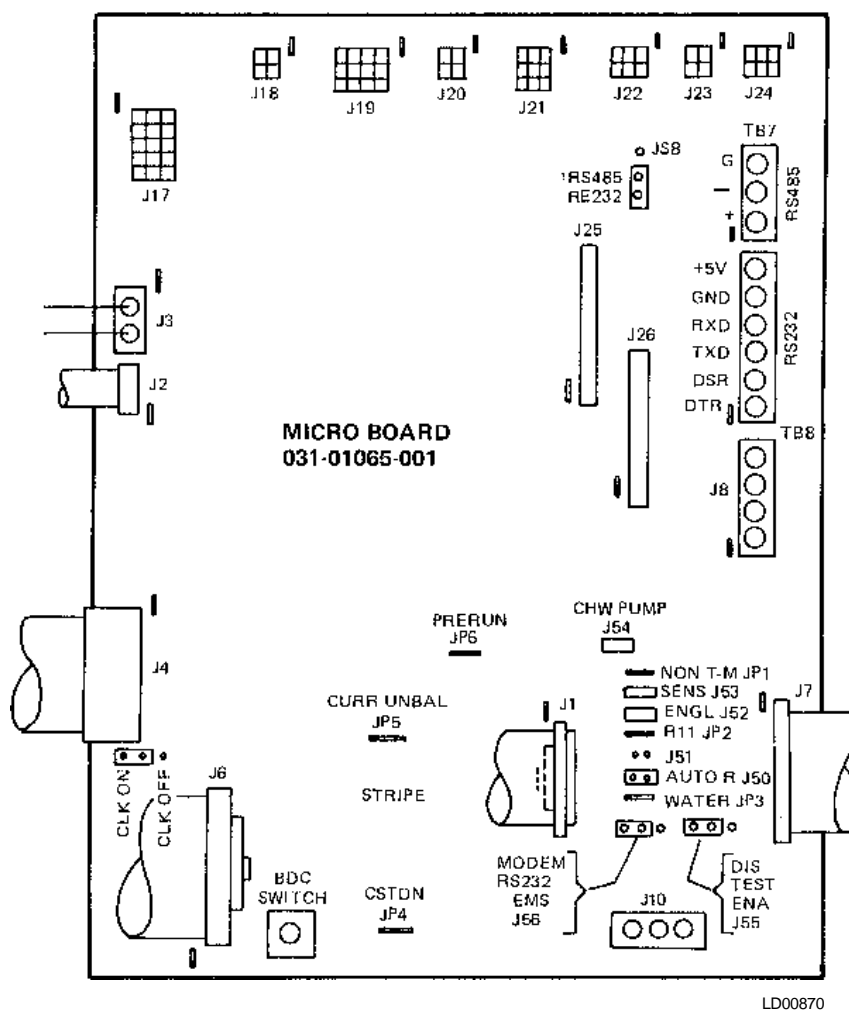

FIG. R – MICRO BOARD JUMPERS FOR AUTO/MANUAL RESTART AFTER POWER FAILURE OR ENGLISH/METRIC DISPLAY UNITS

FIG. R – MICRO BOARD JUMPERS FOR AUTO/MANUAL RESTART OR ENGLISH/METRIC DISPLAY UNITS - This figure shows the location of two jumpers, "Auto Restart" and "English," on the Micro Board which can convert the Control Center Functions. The Micro Board is on the rear panel located directly behind the Control Center key locked door and hinged panel; refer to the Connection Diagram page of Wiring Diagram, Form 155.17-W1 (gas/oil-fired units) or 155.19-W1 (steam-type units). For orientation purposes with the Connection Diagram, see Fig. R.

(1.) Auto Restart Jumper - Control Center is furnished for Manual Restart After Power Failure as a standard function. The Control Center can be field changed to AUTOMATIC restart after a power fail-

ure, if the MANUAL restart feature is not desired. Simply remove jumper from provided bag of parts, and plug in the "Auto Restart" programming JUMPER (Auto R.) on the Micro Board.

(2.) English Jumper - The Control Center can present the "display" in English or Metric System of Units. For English units, temperature display is in degree Fahrenheit (°F) and absolute pressure in pounds per square inch (PSIA). For Metric units, temperature displays is in degree Celsius (°C) and pressure in Kilo-Pascals (KPa). When the Metric system of units is desired, the Micro Board JUMPER ("English"), shown in Fig. R, is removed from the J52 terminals.

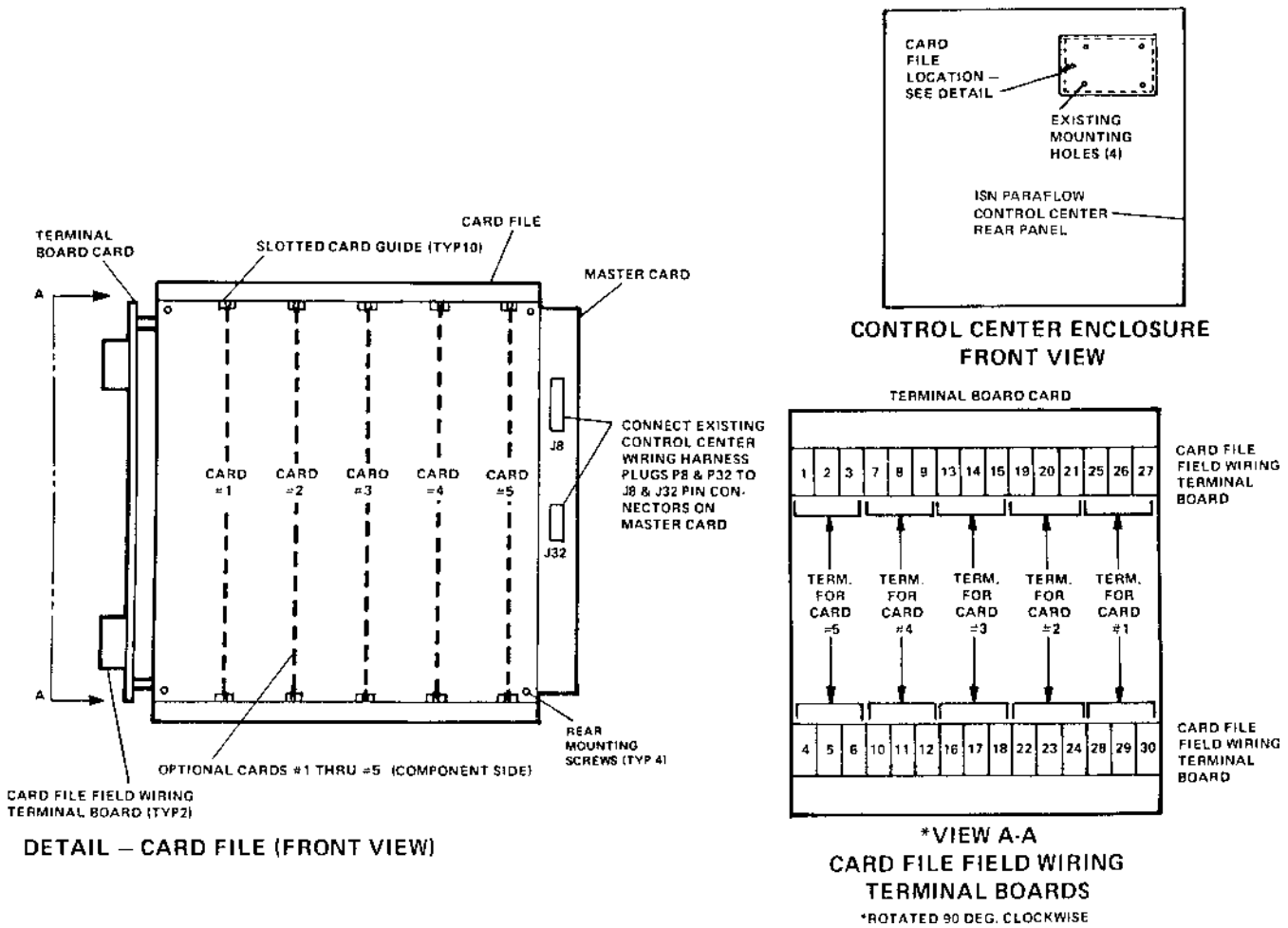

LD00871

FIG. U – CARD FILE

FIG. U – CARD FILE - Designed-in flexibility of the Control Center allows the unit to be tailored for the application - for example, using a 4 to 20 mA D.C. temperature reset signal instead of a 1 to 11 second pulse-width modulated signal, for Remote Temperature Setpoint. The Card File assembly provides the basic control system building block for optional features (when desired). The card file function is to serve as a mounting medium for optional (at additional cost) electronic control printed circuit boards ("cards"). The Card File is a field-installed assembly which includes slotted card guides, a field wiring terminal board card having 30 terminals, and a master card having connectors for option cards. One card file can hold up to five optional cards (at additional cost). The accessible field wiring terminal boards, located on the left end of the card file assembly, provide six field connection terminals for each option - see View A-A. For example, option card #1 would use field wiring terminals numbered 25 thru 30. The Control Center provides the 12 volt D.C. unregulated power to the master card; simply push-on connector plugs P8 & P32 from the control center existing wiring harnesses, to the corresponding master card J8 & J32 pin connectors.

The card file assembly (6" W. x 8-3/4" L. x 6-1/2" Deep overall) is easily field-installed (by others) within the control center enclosure at the "card file" location, on the rear panel, using four standoff mounts, screws and lockwashers (factory furnished) - see Card File Installation Instructions, Form 160.45-N2.2, for more details. At additional cost, order YORK Accessory Part No. 031-00827-000 for the Card File Assembly (with mounting hardware); shipped loose for field installation (by others). Option cards #1 thru #5 are NOT included with the Card File Assembly (refer to Fig. W).

Front loading option cards (#1 thru #5) are field mounted into the Card File via slotted slide card guides, for easy push-in installation and plug connection to master card. Each option card has a keyway to mate with the corresponding key connector on the master card; the option card (#1 thru #5) can only be mounted in the proper card file guides and in the correct position.

Option card #2 provides the user with the capability of remotely controlling leaving chilled or hot water temperature setting. Refer to Fig. W.

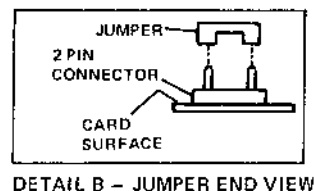
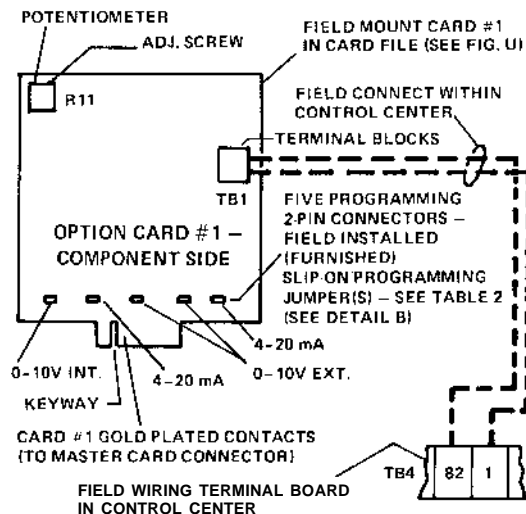

TABLE 2 - JUMPER POSITION FOR CARD #1
PROGRAMMING MODE

SEE DETAIL	TYPE REMOTE INPUT SIGNAL	PROGRAMMING MODE PIN CONNECTORS				
		0-10V INT	4-20 mA	0-10V EXT	0-10V EXT	4-20 mA
1	4 TO 20 mA	---	ON	---	---	ON
2	0 TO 10 VOLTS	---	---	ON	ON	---
3	CONTACT CLOSURE*	ON	---	---	---	---

*ONLY ONE JUMPER IS USED

LD00872

FIG. V - REMOTE STEAM LIMIT SETPOINT - OPTION CARD #1

FIG. V - REMOTE STEAM LIMIT SETPOINT OPTION CARD #1 - A standard feature of the Control Center is to accept a 1 to 11 second pulse-width modulated (PWM) signal (by others) for remote steam limit setpoint. Should the application require an input signal of 4 to 20 mA D.C., or 0 to 10 volts D.C., or a single contact closure for one discrete remote steam limit setpoint - instead of a PWM signal - then option card #1 is required in conjunction with the Card File (see Fig. U). The input signal (by others) can be from an energy management system, etc. The Control Center will only accept the input signal when the control center is in the "remote" mode - see Fig. A. When option card #1 is used, Fig. Q, for PWM signal, cannot be applied. Unit capacity control is from the leaving chilled water temperature, providing the steam limit setpoint is not reached. When unit steam valve exceeds the steam limit setpoint, it will override the temperature control system to reduce unit capacity.

Three input signal choices are available using option card #1. The user first determines which one is desired: (1) 4 to 20 mA D.C., (2) 0 to 10 volts D.C., or (3) single contact closure. Two slip-on programming mode jumpers are furnished with card #1. Simply place the program jumper(s) on the 2-pin connectors (see Detail B) according to the positions indicated by Table 2. Note only one jumper is used if the contact closure mode was chosen.

The optional Card File (Fig. U) must have been previously field-installed (by others) in the Control Center, because it serves as the mounting medium for card #1. Field install (by others) card #1 by just sliding it into the slotted card guides of the Card File; connect the wiring harness (by others) from card #1 terminal block (TB1) to control center terminal board (TB4) as shown.

Input signal wiring is field connected (by others) to the card file field wiring terminals, as shown in Detail 1, 2, or

3 (see Page 14). Select the detail that agrees with how program jumper(s) were positioned on card #1. For more details on card file field wiring terminal board, refer to Fig. U - see View A-A.

The timer circuit on card #1 will permit the unit to begin responding to an input signal change within 150 seconds after the signal is received. Following a remote setpoint signal, the steam limit setpoint changes to the value corresponding to the signal (see Details 1, 2 or 3). When the remote setpoint signal is removed, the setpoint reverts to the programmed maximum load setpoint following a 30 minute built-in time delay. If the Control Center "Pull-down Demand Limit" (standard available function) has been programmed and the unit was started and has run less than the Pull-down Demand Limit timer setting, then the unit will be steam limited by the lower of the Pull-down Demand Limit and the remote steam limit. The Pull-down Demand Limit will automatically transfer control of steam limit function to "remote" at the end of its programmed timed cycle with panel in "remote" operating mode.

Order, at additional cost, YORK Remote Steam Setpoint Option Card, Part No. 031-00814-000; shipped loose for field installation (by others). The optional Card File (Fig. U) is REQUIRED if card #1 is ordered. When Remote Leaving Chilled Water Temperature Control Setpoint option card #2 is also ordered, cards #1 AND #2 are required, but only ONE card file is ordered. Refer to card #1 Installation Instructions, Form 160.45-N2.3.

Option card #1 in Fig. V can be applied in conjunction with Fig. W (option card #2), thus providing the capability of remotely controlling both steam limit setting AND leaving chilled water temperature setting simultaneously, if so desired.

See Page 14 for Details 1, 2 & 3.

DETAIL 1 – Remote Steam Limit Setpoint is accomplished by supplying a 4 to 20 mA D.C. input current signal (by others) across terminals [28] and [30] on the card file field wiring terminal board (see Fig. U). Option card #1 program jumper positions must be per Table 2. A 4 mA signal corresponds to 100% full load amperes and a 20 mA signal corresponds to 20% of full load. The steam limit setpoint varies linearly from 100% to 20%, as the current changes from 4 to 20 mA. Since the lower limit of the steam valve is controlled by a mechanical limit switch (factory adjusted specifically for each unit), the minimum valve position during unit operation is generally 25-30%. For example, 8 mA applied across terminals [28] and [30] of the card file, the current limit setpoint would be as follows:

Remote Current Limit -

$$\text{Setpoint} = 100\% - (\text{mA signal} - 4) 5.0\%$$

$$\text{Setpoint} = 100\% - (8 - 4) 5.0\% = 100\% - 20\% = 80\%$$

DETAIL 2 – Remote Steam Limit Setpoint is accomplished by supplying a 0 to 10 volt D.C. input voltage signal (by others) across terminals [28] and [30] on the card file field wiring terminal board (see Fig. U). Option card #1 program jumper positions must be per Table 2. A 0 volt D.C. signal corresponds to 100% of full load. The steam limit setpoint varies linearly from 100% to 20% as the voltage changes from 0 to 10 volts D.C. Since the lower limit of the steam valve is controlled by a mechanical limit switch (factory adjusted specifically for each unit), the minimum valve position during unit operation is generally 25-30%. For example, 4 volts D.C. applied across terminals [28] and [30] of the card file, the steam limit setpoint would be as follows:

Remote Steam Limit -

$$\text{Setpoint} = 100\% - (\text{D.C. voltage signal}) 8\%$$

$$\text{Setpoint} = 100\% - (4) 8\% = 100\% - 32\% = 68\%$$

DETAIL 3 – Remote Steam Limit Setpoint is accomplished by supplying a single dry circuit contact closure, 2 milliamperes @ 12 volts (by others) across terminals [25] and [26] on the card file field wiring terminal board (see Fig. U). Option card #1 program jumper (one) position must be per Table 2. The contact closure provides one discrete remote steam limit setpoint corresponding to the % (100 to 20) full load setting (screw adjustable) that has been previously field selected (by others) on card #1 potentiometer (R11) - see top left corner of card #1. Since the lower limit of the steam valve is controlled by a mechanical limit switch (factory adjusted specifically for each unit), the minimum valve position during unit operation is generally 25-30%.

The maximum rate at which the Control Center will accept remote steam limit setpoint mA is once each 150 seconds.

For remote steam limit setpoint via a 0 to 10 volt D.C. signal - see Detail 2, or a single contact closure - see Detail 3. Refer to Fig. Q for pulse width modulated signal.

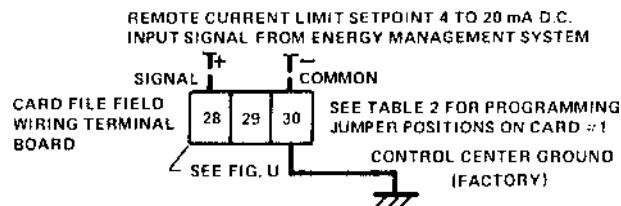

LD00873

DETAIL 1 – 4 TO 20 mA D.C. INPUT CURRENT SIGNAL CONNECTIONS

The maximum rate at which the Control Center will accept remote steam limit setpoint D.C. voltage signal is once each 150 seconds.

For remote steam limit setpoint via a 4 to 20 mA D.C. signal - see Detail 1, or a single contact closure - see Detail 3. Refer to Fig. Q for pulse-width modulated signal.

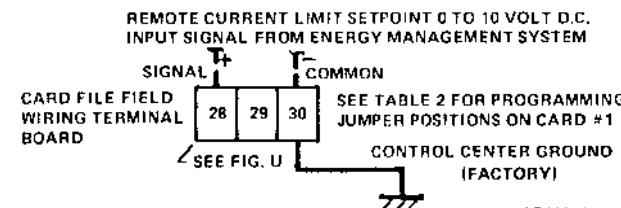

LD00874

DETAIL 2 – 0 TO 10 VOLT D.C. INPUT VOLTAGE SIGNAL CONNECTIONS

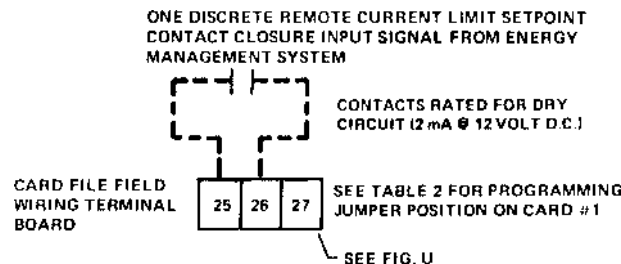

LD00875

DETAIL 3 – CONTACT CLOSURE INPUT SIGNAL CONNECTIONS

FIG.V (Continued) – REMOTE STEAM LIMIT SETPOINT (STEAM UNITS ONLY) – OPTION CARD #1

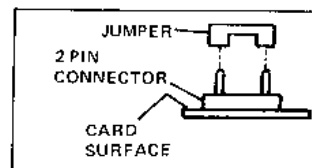
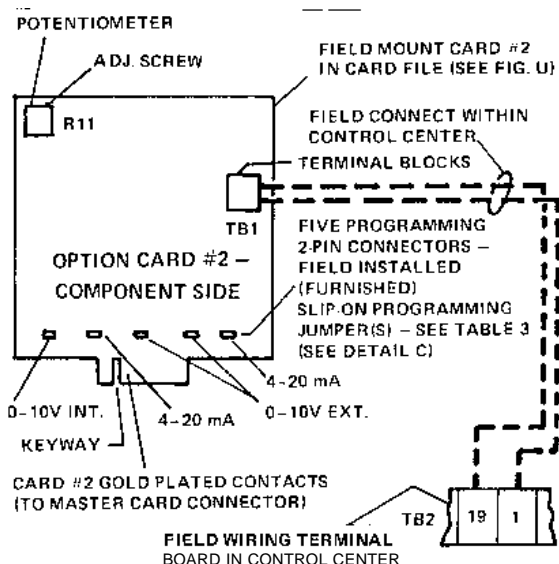

DETAIL C - JUMPER END VIEW

TABLE 3 - JUMPER POSITION FOR CARD #2 PROGRAMMING MODE

SEE DETAIL	TYPE REMOTE INPUT SIGNAL	PROGRAMMING MODE PIN CONNECTORS			
		0-10V INT	4-20 mA	0-10V EXT	0-10V EXT
1	4 TO 20 mA	---	ON	---	ON
2	0 TO 10 VOLTS	---	---	ON	ON
3	CONTACT CLOSURE*	ON	---	---	---

*ONLY ONE JUMPER IS USED

LD00876

FIG. W - REMOTE LEAVING CHILLED OR HOT WATER TEMPERATURE SETPOINT OPTION CARD #2 (NOTE 14)

FIG. W - REMOTE LEAVING CHILLED OR HOT WATER TEMPERATURE OPTION CARD #2 - A standard feature of the Control Center is to accept a 1 to 11 second pulse-width modulated (PWM) signal (by others) for remote leaving chilled or hot water temperature setpoint. Should the application require an input of 4 to 20 mA D.C., or 0 to 10 volts D.C., or a single contact closure for one discrete remote leaving chilled water temperature - instead of a PWM signal - then option card #2 is required in conjunction with the card file (see Fig. U). The input signal (by others) can be from an energy management system, etc. The Control Center will accept only the input signal when the control center is in the "remote" mode - see Fig. A. When option card #2 is used, Fig. P, for PWM signal, cannot be applied. Unit capacity control is from the leaving chilled or hot water temperature, providing the maximum cooling or heating load setpoint is not reached.

The Control Center can be programmed via "Remote Reset Temp. Range" setpoint key for a 10°F or 20°F leaving chilled or hot liquid temperature reset range. Then automatic remote temperature reset range. Then automatic remote temperature reset is accomplished by supplying (by others) the input signal to the card file field wiring terminal board shown in Fig. U. three input signal choices are available using option card #2. The user first determines which one is desired: (1) 4 to 20 mA D.C., (2) 0 to 10 volts D.C., or (3) single contact closure. Two slip-on programming mode jumpers are furnished with card #2. Simply place the program jumper(s) on the 2-pin connectors (see Detail C) according to the positions indicated by Table 3. Not only one jumper is used if the contact closure mode was chosen.

The optional card file (Fig. U) must have been previously field installed (by others) in the Control Center, because it serves as the mounting medium for card #2. Field install (by others) card #2 by just sliding it into the slotted card guides of the Card File; connect the wiring harness (by others) from card #2 terminal block (TB1) to control center terminal board (TB2) as shown. Input signal wiring is field connected (by others) to the card file field wiring terminals, as shown in Detail 1, 2 or 3 (see Page 17). Select the detail that agrees with how program jumper(s) were positioned on card #2. For more details on card file field wiring terminal board, refer to Fig. U - see View A-A.

The timer circuit on card #2 will permit the unit to begin responding to an input signal change within 150 seconds after the signal is received. Following a remote setpoint signal, the leaving chilled or hot water temperature setpoint changes to the value corresponding to the signal (see Details 1, 2 or 3). When the remote setpoint signal is removed, the setpoint reverts to the programmed leaving chilled or hot water temperature following a 30 minute built-in time delay.

Order, at additional cost, YORK Remote Leaving Chilled or Hot Water Temperature Setpoint Option card, Part No. 031-00814-000; shipped loose for field installation (by others). The optional card file (Fig. U) is REQUIRED if card #2 is ordered. Refer to card #2 Installation Instructions, Form 160.45-N2.3.

See Page 16 for Details 1, 2, & 3.

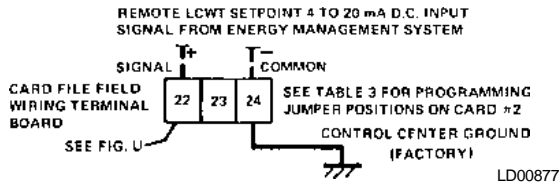

DETAIL 1 – 4 to 20 mA INPUT CURRENT SIGNAL CONNECTIONS

DETAIL 1 – Remote Leaving Chilled or Hot Water Temperature Setpoint is accomplished by supplying a 4 to 20 mA D.C. input current signal (by others) across terminals **22** and **24** on the card file field wiring terminal board (see Fig. U). Option card #2 program jumper positions must be per Table 3. A 4 mA signal corresponds to zero deg. F offset and therefore at the programmed leaving chilled or hot water temperature setpoint. A 20 mA signal corresponds to maximum offset (10°F or 20°F as programmed) above the programmed leaving chilled water temperature setpoint or below the programmed leaving hot water temperature setpoint. The amount of offset varies linearly with the 4 to 20 mA signal. For example, 12 mA applied (across terminals **22** and **24** of the card file) to the unit programmed for 45°F leaving chilled water temperature setpoint and 10°F “Remote Reset Temp. Range”, the new setpoint would be:

Temperature Offset -

$$\text{Deg. F Offset} = \frac{(\text{mA signal} - 4)(\text{remote reset temp. range})}{16}$$

$$\text{Deg. F Offset} = \frac{(12 - 4)(10)}{16} = 5^\circ\text{F}$$

Remote Cooling Setpoint = Keypad entered setpoint + °F offset

Remote Heating Setpoint = Keypad entered setpoint - °F offset

Thus, the new leaving chilled water temperature control point is 45°F + 5°F = 50°F.

The maximum rate at which the Control Center will accept remote leaving chilled or hot water temperature setpoint mA signal is once each 150 seconds.

For remote leaving chilled or hot water temperature setpoint via a 0 to 10 volt D.C. signal - see Detail 2, or a single contact closure - see Detail 3. Refer to Fig. P for pulse-width modulated signal.

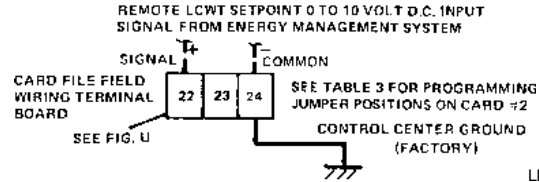

DETAIL 2 – 0 to 10 mA VOLT D.C. INPUT VOLTAGE SIGNAL CONNECTIONS

DETAIL 2 – Remote Leaving Chilled or Hot Water Temperature Setpoint is accomplished by supplying a 0 to 10 volt D.C. input voltage signal (by others) across terminals **22** and **24** on the card file field wiring terminal board (see Fig. U).

Option card #2 program jumper positions must be per Table 3. A 0 volt signal corresponds to zero deg. F offset and therefore at the programmed leaving chilled or hot water temperature setpoint. A 10 volt D.C. corresponds to maximum offset (10°F or 20°F as programmed) above the programmed leaving chilled water temperature setpoint or below the programmed leaving hot water temperature setpoint. The amount of offset varies linearly with the 0 to 10 volt D.C. signal. For example, 5 volts D.C. applied (across terminals **22** and **24** of the card file) to the unit programmed for 45°F leaving chilled water temperature setpoint and 10°F “Remote Reset Temp. Range.” The new setpoint would be:

Temperature Offset -

$$\text{Deg. F Offset} = \frac{\text{D.C. voltage signal}(\text{remote reset temp. range})}{10}$$

$$\text{Deg. F Offset} = \frac{(5)(10)}{10} = 5^\circ\text{F}$$

Remote Cooling Setpoint = Keypad entered setpoint + °F offset

Remote Heating Setpoint = Keypad entered setpoint - °F offset

Thus, the new leaving chilled water temperature control point is 45°F + 5°F = 50°F.

The maximum rate at which the Control Center will accept remote leaving chilled or hot water temperature setpoint D.C. voltage signal is once each 150 seconds.

For remote leaving chilled or hot water temperature setpoint via a 4 to 20 mA signal - see Detail 1, or a single contact closure, see Detail 3. Refer to Fig. P for pulse-width modulated signal.

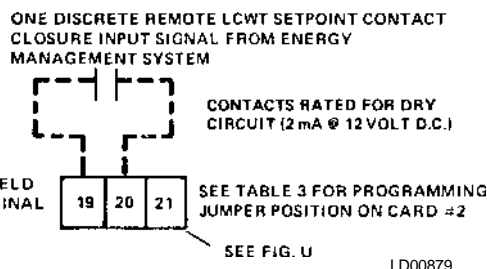

DETAIL 3 – CONTACT CLOSURE INPUT SIGNAL CONNECTIONS

FIG.W (Continued) – REMOTE LEAVING CHILLED OR HOT WATER TEMPERATURE SETPOINT OPTION CARD #2 (NOTE 15)

DETAIL 3 – Remote Leaving Chilled or Hot Water Temperature Setpoint is accomplished by supplying a single dry circuit contact closure, 2 milliamperes @ 12 volts (by others) across terminals **19** and **20** on the card file field wiring terminal board (see Fig. U). Option card #2 program jumper (one) position must be per Table 3. The contact closure provides one discrete remote leaving chilled or hot water temperature setpoint corresponding to the leaving chilled or hot water temperature setting (screw adjustable) that has been previously field selected (by others) on card #2 potentiometer (R11) - see top left corner of card #2.

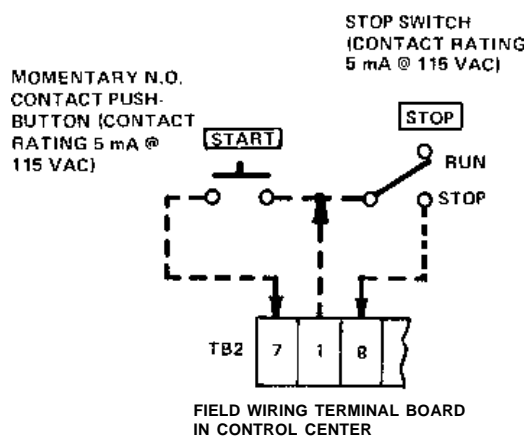

LD00880

FIG. X – REMOTE START-STOP PUSHBUTTON STATION

FIG. X – REMOTE START - STOP STATION - When the Remote Start-Stop contacts (see Fig. E) are not connected to an Energy Management System, terminals **7**, **1** and **8** on terminal board TB2 may be connected to a Remote Start-Stop Station. Whenever the Control Center is in the “remote” operating mode, the unit can be started and stopped from a remote location by employing a momentary normally open contact pushbutton for Remote Start and a maintained switch for Remote Stop.

NOTE – Remote Start - Stop Station only functions in “remote” operating mode.

When the Remote Mode Ready to Start contacts close in Fig. A (meaning the panel is in the “remote” operating mode and the “unit” switch is in the “run” position (**1** to **8** open), the unit will start via a momentary closure of the Remote Start Pushbutton. A subsequent closure of the maintained Remote Stop Switch to the “stop” position causes the unit to shutdown. The Millennium Control Center will display the following message: “SYSTEM SHUTDOWN - PRESS STATUS.” Upon pressing “status” key “REMOTE STOP” message will be displayed when the Remote Stop switch has commanded the unit to shutdown.

NOTE – Even when the unit is applied with Remote Start-Stop (when the panel is in the “remote” operating mode), an EMERGENCY STOP by an operator or others can STOP the compressor from the Control Center and prevent the unit from restarting. However, the operator cannot locally start the unit using “unit” start switch, when the panel is in the “remote” operating mode. To enter “remote” operating mode, a four digit access code must be entered for security.

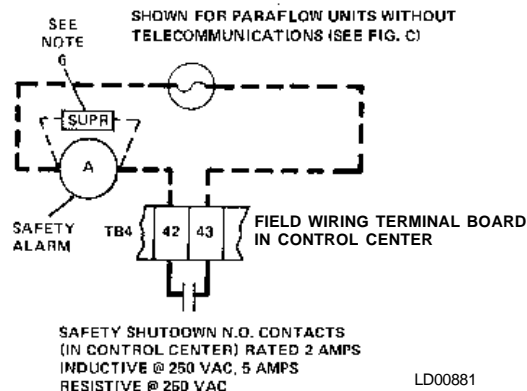

LD00881

FIG. Y – EXTERNAL SIGNAL FOR SAFETY SHUTDOWN (NOTE 6)

FIG. Y – EXTERNAL SIGNAL FOR SAFETY SHUTDOWN - When the Safety Shutdown Contacts (see Fig. C) are not connected to an Energy Management System, they may be employed to energize a local or remote safety alarm (by others). When the normally open Safety Shutdown Contacts close, the alarm will indicate shutdown of one unit. The cause of shutdown will be one of more of the following safety controls: (1) Solution or refrigerant pump overloads or thermal switches tripped/open (cooling mode only); (2) Low refrigerant temperature cutout at 39.1°F (cooling mode only); (3) First stage generator high pressure cutout at 13.73 PSIA (analog backup at 15.00 PSIA); (4) First stage generator high temperature cutout at 330°F (analog backup at 337°F); (first stage generator low solution level switch cutout (gas/oil-fired units only); (5) Burner alarm indicator contacts open (gas/oil-fired units only); (6) Power Failure (when the “Auto Restart After Power Failure” jumper is removed from the Micro Board - see Fig. R; (7) Chilled water flow switch open (in cooling mode); (8) “Burner on” contacts open for 10 seconds continuously during unit run (or after a 180 second bypass during the start sequence); (9) Following a power failure, if the solution dilution temperature is less than 136°F when power is restored and the unit did not complete its previous dilution cycle, check the levels in the absorber and generator; (10) If, after a shutdown as described in item (1), when the solution or refrigerant pump overloads or thermal switches reclose, if the solution dilution temperature is less than 136°F, check the levels in the absorber and generator; (11) When the low refrigerant temperature cutout switch recloses or the refrigerant temperature sensor temperature rises to 44°F (whichever device caused the shutdown), if the solution dilution temperature is less than 136°F, check the levels in the absorber and generator; (12) If the chilled water flow switch recloses after shutdown as described in item (7) and the solution dilution temperature is below 136°F, check the levels in the absorber and generator. In items (9), (10), (11), and (12), after the levels are properly adjusted, the unit must be manually reset by pressing the “warning reset” key in “service” mode.

Continued on Page 18.

FIG. Y – Continued

When all safety controls are satisfied, the Control Center “unit” switch has been placed in the “stop/reset” position (de-energizing the alarm) and then in the “run” position, the unit may be restarted, if the control center is in “remote” mode, via the Remote Start Contacts (Fig. E); or if the control center is in “local” mode the unit may be started by pressing the keypad-mounted “unit” switch to the “start” position. When all safety controls are satisfied, and the control center “unit” switch has been manually “reset” (de-energizing alarm) and returned to the “run” position the unit may be restarted, if control center is in “remote” mode, via the Remote Start contacts (Fig. E) or if control center is in “local” mode by pressing keypad unit “Start” switch.

NOTE – If the unit was shutdown because of Cycling Shutdown Contacts (see Fig. B) the alarm will not be energized, but the unit will have been shutdown. A closure of the safety alarm contacts means that an operator must manually reset and restart the unit.

When the Safety Shutdown contacts close, the control center will display the following message: “SYSTEM SHUTDOWN - PRESS STATUS.” Upon pressing “status” key, the status message consists of the day and time of shutdown plus cause of shutdown.

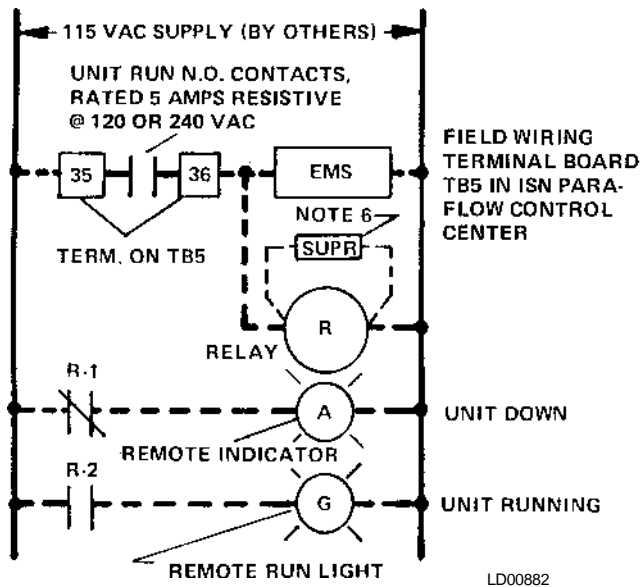

FIG. AA – RUN CONTACTS/REMOTE RUN LIGHT AND SHUTDOWN INDICATOR PLUS EMS -When run contacts are required for a Remote Run Light and/or Shutdown Indicator AND Energy Management System (EMS), connect (by others) as shown in the diagram. The EMS, control relay, shutdown and run lights are furnished by others. When the N.O. contacts close, between terminals 35 and 36 on field wiring terminal board TB5 in the Control Center, this indicates that the unit is operating; the remote Run Light will be energized. The unit run contacts open when the Millennium unit is shutdown (safety or cycling) and the remote indicator will then be energized. For run contacts to EMS only refer to Fig. D. When terminals 35 and 36 are not used for an EMS, they may be connected to a remote Run Light. The control relay scheme shown in Fig. AA can also be applied for a remote Run Light AND a Remote Shutdown Indicator, when an EMS is not used.

FIG. AA – RUN CONTACTS/REMOTE RUN LIGHT AND SHUTDOWN INDICATOR PLUS EMS

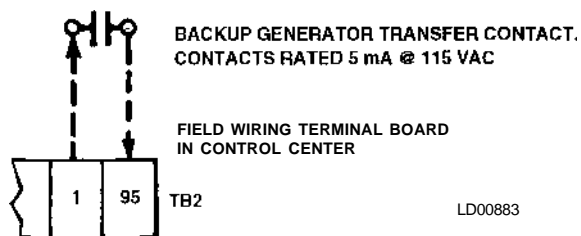

FIG. BB – BACKUP GENERATOR TRANSFER

FIG. BB – BACKUP GENERATOR TRANSFER -

During a prolonged power failure (disallowing a dilution operation) the unit could crystallize depending on length of power failure, level of insulation, and operating condition at time of power failure. By adding a small standby AC power supply, the solution pump (or all 3 solution pumps for multiple solution pump chillers) can perform a limited dilution as follows:

NOTE: This system does not allow for continued production of chilled water; it is only a dilution cycle to protect the chiller.

If a dilution is not required the unit will not enter a limited dilution cycle during Standby Power. Instead, the following message will be displayed: "SUN 12:00AM STANDBY POWER-UNIT LOCKOUT."

If the chiller experiences a power failure, the input (95) on TB2 is checked for a closed contact (indicating that a Standby Power Supply is on-line). This closure signifies to the Control Panel that a Limited Dilution cycle should be performed, if required. If a dilution cycle is required and the solution temperature is 136.0°F or less, a form of the message: "SUN 12:00-LD-CHK SOL'N LVL-ABS & GEN" will appear, and no dilution will be performed. This possible crystallization fault can only be cleared by placing the UNIT SWITCH in the STOP/RESET position and pressing the WARNING RESET button while in SERVICE operating mode.

If condenser flow is sensed (through the flow switch closure) when a Limited Dilution cycle is desired, a message of the form "SUN 12:00AM-FLS-LIMITED-DIL'N OVERRIDE" is displayed. The chiller will then experience a cycling shutdown, with resumption of the Limited Dilution cycle only after the flow is terminated. If, however, during the period of condenser flow, the Solution temperature has decreased below 136.0°F, a form of the message: "SUN 12:00AM-LD-CHK SOL'N LVL-ABS & GEN" will be displayed and the Limited Dilution cycle will not restart. The same message will be displayed and the Limited Dilution cycle will be interrupted if the Solution Pump Overloads should open before a dilution has been completed.

If a Limited Dilution cycle is initiated, the foreground message: "SYSTEM SHUTDOWN-PRESS STATUS" is

displayed. Pressing the STATUS key will produce a form of the message "SUN 12:00AM SOL'N PUMP ONLY DIL'N CYCLE" while the Limit Dilution cycle is in progress, and a form of the message: "SUN 12:00AM STANDBY POWER-UNIT LOCKOUT" after the Limited Dilution cycle is completed. The Limited Dilution cycle is normally terminated only after four hours of execution.

All other chiller operations are disabled during the standby power supply operation and can not be manually overridden.

Restoration of utility power causes two different dilution reactions dependent upon the length of the power failure.

If the length of utility power failure was less than one minute, and the unit was in the middle of a Limited Dilution cycle when power was restored, the unit shall ignore the normal possible crystallization lockout based on the Solution Temperature being below 136.0°F. If the unit is in AUTO RESTART the unit shall come up and run normally. If the unit is in MANUAL RESTART, a normal dilution is performed; manual intervention is then required, with the UNIT SWITCH, to start.

If the length of power failure was greater than one minute, and the unit was in the middle of a Limited Dilution cycle when power was restored, the possible crystallization lockout based on the Solution Temperature being below 136.0°F shall be ignored. Instead, the unit shall initiate a Normal Dilution cycle. If the unit is in AUTO RESTART the unit will run following the Normal Dilution cycle. If the unit is in MANUAL RESTART manual intervention with the UNIT SWITCH is required to allow the unit to run following the completion of the Normal Dilution.

If the unit is not executing Limited Dilution during power restoration and a Dilution cycle is requested, and the Solution Temperature is less than 136.0°F upon power restoration, the unit shall shutdown on a possible crystallization fault and display the following: "SUN 12:00AM-LDCHK SOL'N LVL-ABS & GEN."

If a Limited Dilution cycle is completed during a standby power condition, no Normal Dilution cycle will be performed when utility power is restored.

NOTES

1. This drawing shows recommended field control wiring modification (by others) to the standard Control Center wiring diagram. Refer to Control Center Wiring Diagram: Product Drawing Form 155.17-W1, gas/oil-fired units; Product Drawing Form 155.19-W1, steam-type units.
2. If more than one of these modifications is to be utilized with a particular unit, additional consideration must be given to the application to insure proper functioning of the control system. Consult your YORK representative.
3. The additional controls and wiring for these modifications are to be furnished and installed in the field (by others).
4. The controls specified are recommended for use, but other control of equal specifications are acceptable.
5. All wiring shall be in accordance with the National Electrical Code, and applicable State and Local Codes.
6. Each 115 VAC field connected inductive load; i.e., relay coil, motor starter coil, etc., shall have a transient suppressor wired (by others) in parallel with its coil, physically located at the coil. Spare transient suppressors are furnished in a bag in the Control Center.
7. The Control Center is factory furnished for Manual Restart After Power Failure as a standard function. The control center can be field changed from Manual Restart to Auto Restart after a power failure by plugging in a programming jumper – see Fig. R.
8. Two (2) unit control schemes are suitable for 8-12°F water range. Constant chilled water flow is assumed at all loads. For other requirements, contact your YORK representative.
9. Lead selector and cycling control to provide similar lead selection and cycling of lag units for three (3) units is available: Kit No. 366-44684D (see Product Drawing Form 160.00-PA1.1) in NEMA I enclosure; for 4 units, Kit No. 366-52529D (see Product Drawing Form 160.00-PA1.2) in NEMA I enclosure. Consult your YORK representative.
10. Sequence control kits (see Fig. J and Note 10) assume a constant chilled water flow and a constant leaving chilled water temperature to sense the cooling load. Sequence control kits are not designed for variable chilled water flow or with reset of the leaving chilled water temperature - see Figs. P & W and Note 2.
11. For steam type units only, the maximum allowable current draw between circuits **5** and **2** for field installed devices is 1 amp holding and 10 amps inrush - see Control Center Wiring Diagram Form No. referenced in Note 1.
12. For required connections of the chilled water pump contacts (terminals **44** and **45**), condenser water pump contacts (terminals **55** and **56**), and hot water pump interlock or flow switch (gas/oil-fired units only) (terminals **1** and **82**), and hot water pump, the chilled water pump flow switch (terminals **1** and **12**), and condenser water pump interlock or flow switch (terminals **1** and **20**), located on TB2, refer to Form 155.17-W1 for gas/oil-fired units or Form 155.19-W1 for steam-type units.

The chilled water flow switch is a safety control. It must be connected to prevent operation of the unit whenever chilled water flow is stopped. The use of the chilled water flow switch for purposes other than protection of the unit may be accomplished in several ways: two flow switches or a flow switch and a relay.
13. Do not apply voltage on field wiring terminal boards TB2 and TB5 in Control Center, as 115 VAC source is fed from terminal **1** and **2**.
14. Entering and leaving chilled and condenser water temperature sensors are supplied by YORK as a standard item on all units.

