



ABSORPTION LIQUID CHILLER

OPERATION

Supersedes: 155.17-02(1292)

1296

FORM 155.17-02

MILLENNIUM CONTROL CENTER

PART NO. 371-01288-101

FOR

ABSORPTION UNIT INSTALLATION, OPERATION, MAINTENANCE— YPC ABSORPTION CHILLER/HEATERS

155.17-W1—GAS/OIL-FIRED UNIT WIRING

155.17-PA1—FIELD CONTROL MODIFICATIONS, ALL UNITS

155.17-PA2—FIELD CONNECTIONS, ALL UNITS

155.19-W1—STEAM UNIT WIRING

155.17-M2—MICROCOMPUTER CONTROL CENTER SERVICE MANUAL

TABLE OF CONTENTS

THEORY OF OPERATION	3	PROGRAMMING THE	
Overview	3	YPC CONTROL CENTER	124
Operation	3	Programming Setpoints	124
Dilution Cycle (Automatic)	7	SERVICE KEYS	130
Dilution (Manual)	8	Unit Keys	130
Purge (Manual)	9	Other Service Keys	130
Purge (Automatic)	10	OPERATION MODES	133
Purge Counters	11	UNIT SWITCH	134
OPERATION FLOW CHART	13	DISPLAY MESSAGES	134
CONTROL CENTER	116		
OPERATION	117		
Displaying System Parameters	117		
System Setpoints	119		
Displaying System Setpoints	121		
LiBr Concentration Calculator	123		

WARNING

This equipment generates, uses, and can radiate radio frequency energy, and if not installed and used in accordance with the instructions manual, may cause interference to radio communications. It has been tested and found to comply with the limits for Class A computing devices pursuant to Subpart J of Part 15 of FCC Rules, which are designed to provide reasonable protection against such interference when operated in a commercial environment. Operation of this equipment in a residential area is likely to cause interference, in which case the user at his own expense will be required to correct the interference.

Additionally, any electronic equipment can generate EMI (electromagnetic interference), which, depending upon the installation and magnitude, may affect other electronic equipment. The amount of EMI generated is determined by the source inductance, load inductance, and circuit impedances. Responsibility for assuring the satisfactory operation of other equipment included in the same power source as the YORK equipment rests solely with the user. YORK disclaims any liability resulting from any interference or for the correction thereof.

THEORY OF OPERATION

OVERVIEW

An understanding of the operation of an absorption chiller/heater requires a review of the chiller's micro panel wiring diagram, power panel wiring diagram, the keypad drawing, and the description which follows. Major system components include the solution pump(s) (1 or 3 are used); refrigerant pump; purge (vacuum) pump; gas-fired burner and burner controls or steam valve actuator and steam shutoff valve; first stage generator pressure transducer, temperature sensor, low solution level switch (gas/oil-fired units only) and high pressure and high temperature cutout switches; solution dilution temperature sensor; chilled, condenser, and hot water (gas-fired units only) flow switches (condenser and hot water flow switches furnished by others); chilled, condenser, and hot water (gas-fired units only) pumps (furnished by others); low refrigerant temperature switch; and inlet and outlet temperature sensors for chilled, condenser, and hot water (gas/oil-fired units only) circuits.

The standard "G" series gas/oil-fired unit allows it to be employed as a chiller or as a heater or both. Steam units operate only as chillers. In heating mode, the burner on a gas-fired unit heats the first stage generator, which in turn heats the auxiliary hot water heat exchanger. The selection of which setpoint is in control, cooling, heating, or simultaneous operation is made by the operator via the panel keypad. Changeover is allowed only when the **UNIT** switch is in the **STOP/RESET** position and the dilution cycle has ended. When the **COOL/HEAT CHANGEOVER** key is depressed in the **PROGRAM** mode, the displayed message will be

COOLING (OR HEATING) MODE - VALVE ADJUSTMENT REQUIRED

If the **CHANGEOVER** key is depressed in the **PROGRAM** mode when the unit is running or in the dilution cycle, the display will read

CHANGEOVER DISABLED DURING RUN/DILUTION

Selecting simultaneous **COOLING AND HEATING** mode is identical to **COOLING ONLY** mode except that the hot water pump contacts close whenever the chilled water pump contacts close. Also, the position of the hot water flow switch is ignored in **COOLING AND HEATING** mode.

The "S" series gas/oil-fired units can be supplied with additional lines and valves to operate in a low temperature heating mode up to 140°F. These units do not have a separate heat exchanger. The evaporator is used to chill water in **COOLING ONLY** mode and heat water in **HEATING ONLY** mode. Therefore, simultaneous **COOLING AND HEATING** mode cannot be selected. When these units are operating in **HEATING ONLY** mode,

micro board program jumper JP2 must be removed. This causes the refrigerant, hot water, and all solution pumps to run during heating operation. The refrigerant pump start is delayed for 10 minutes at unit start. The allowable hot water setpoint range is 90° to 140°F.

"S" series units equipped with the high temperature option have a separate heat exchanger and are capable of heating water to 175°F. These units can operate in **COOLING ONLY**, **HEATING ONLY** and **COOLING AND HEATING** modes.

OPERATION

Whenever power is applied to the micro panel in the **COOLING**, **HEATING** or **COOLING/HEATING** modes, the following safety checks are performed: first stage generator high pressure, high temperature and low solution level (gas/oil-fired units only), burner control panel remote alarm contacts, burner panel malfunction, low refrigerant temperature switch, and all other standard customer interface run-permissive contacts. The steam valve potentiometer, when open about 10%, prevents unit start by providing a unit cycling shutdown. Whenever power is applied, the status of the purge pump motor overloads is checked, and if tripped, they produce a background (status) message

WARNING: PURGE PUMP OVERLOADS OPEN

when the unit is running or a foreground message

SYSTEM READY TO START - PURGE OL FAULT

whenever the unit is off. Except in the heating mode, the solution and refrigerant pump overloads and thermal switches are checked whenever power is applied; if tripped, they produce a

SYSTEM SHUTDOWN - PRESS STATUS

message with the appropriate status message. Manual operation of the solution, second spray solution, refrigerant, purge, chilled, condenser, hot water pumps, and manual dilution cycle is controlled via the **MANUAL PUMP** key in the **SERVICE** section of the keypad. The **PUMP STATUS** key employs a scrolling feature to allow control of the pumps and the manual dilution cycle via the **MANUAL PUMP** key. In the **SERVICE** mode, each pump may be operated manually if not already required to run due to chiller/heater operation or the dilution cycle. The pump will be on for 2 hours (except the purge pump, which requires manual turn off) and then automatically turn off. While the **PUMP STATUS** key is used to display the message

MANUAL DILUTION CYCLE

the **MANUAL PUMP** key (in the **SERVICE** mode only) allows on/off operation of the manual dilution cycle; with the unit off and not in the automatic dilution cycle, it initiates a dilution cycle regardless of the solution dilution temperature. When activated, the solution, refrigerant, chilled and condenser pumps run until the solution dilution temperature falls to 136°F or a minimum of 10 minutes. To stop the manual dilution cycle before automatic termination, press the **MANUAL PUMP** key again. The on/off status for all pumps is provided on the unit printout. In **LOCAL** or **REMOTE** or **SERVICE** mode, the **MANUAL PUMP** key is used in conjunction with the pump status key to control operation of the purge pump to allow manual purge operation when the optional auto purge is off.

To initiate a start in local operating mode, press the **UNIT** switch on the keypad. The micro panel checks to determine which setpoint, chilled or hot water (gas-fired units only), is controlling the chiller. In **COOLING** or **COOL/HEAT** mode, the panel displays the message

COOLING START SEQUENCE INITIATED

However, the chilled water and condenser flow switches are bypassed for 30 seconds, or until the unit starts, if less than 30 seconds. The allowable system starting temperature is equal to the leaving temperature setpoint. If the unit is kept from starting because the leaving water temperature is below setpoint, a cycling shutdown will be initiated, with the background message

DAY - TIME - LVG WATER TEMP BELOW SETPOINT

For LWT (low water temperature) shutdowns only, the system will restart when the leaving chilled water temperature increases to $\geq 1^\circ\text{F}$ above the setpoint if setpoint is $\geq 43.0^\circ\text{F}$. If setpoint $< 43.0^\circ\text{F}$, restart occurs at 44.0°F . The LWT shutdown occurs when the leaving chilled water temperature decreases to 3.0°F below setpoint or a minimum of 40.0°F . If the setpoint is increased while the unit is running, the shutdown threshold remains the same as the previous threshold for 30 minutes to eliminate nuisance trips. Following an LWT shutdown, a dilution cycle is performed. Following the dilution cycle, the chilled water pump continues to run. If one or more of the system status checks is negative, the panel displays the

SYSTEM SHUTDOWN - PRESS STATUS

message with the appropriate background message. If the checks are all normal, the chilled and condenser water pumps are started immediately. When the chilled water flow switch closes (on gas-fired units only), a burner control signal is sent to the burner panel via 1R relay in the micro panel. In approximately 30 to 90 seconds, after the burner control panel completes its pre-purge and safety checks, the main flame is established. At this point, the burner control closes the circuit

between its terminals 38 and 39, providing an indication to the micro panel via a digital input. Subsequently, the panel starts the solution and refrigerant pumps, displaying the message

SYSTEM RUN - LEAVING CHILLED WATER CONTROL

Models 19GL through 22G have a solution pump, a first spray solution pump and a delayed-on second spray solution pump. The second spray solution pump is turned on 30 to 120 seconds (10 to 120 seconds with EPROM version A.01F.09 or later) after the solution pump and first spray solution pump. The delay time is programmed with the **Spray Solution Pump Delay** setpoint. Both the default and nominal delays are 90 seconds. Models 16SL through 19S have a solution pump and a delayed-on spray solution pump; the spray solution pump is started 30 to 120 seconds (10 to 120 seconds with EPROM version A.01F.09 or later; as programmed with the **Spray Solution Pump Delay** setpoint) after the solution pump. Gas-fired models 20G through 22G employ two first stage generators which require two high pressure cutout switches, pressure transducers, two temperature sensors, two high temperature cutout switches, and one solution level switch with two level sensors. Coincident with the contact closure between burner terminals 38 and 39 (burner on indication), a software timer is initiated, maintaining the burner at minimum fire, delaying the automatic temperature-controlled operation of the burner. This function prevents unstable burner operation due to a "cold" stack. The default delay is 4 minutes; however, the delay is programmable from 0 to 10 minutes via the **DISPLAY DATA** key when accessed in **PROGRAM** mode with the special access code. After a 180-second bypass during the "Start Sequence" or anytime during the "System Run" condition, if the burner on contacts open for 10 seconds continuously, the panel initiates a safety shutdown, displaying the message

DAY - TIME - BURNER PANEL MALFUNCTION

The preceding message indicates that the burner control switch is OFF, that one (or more) of the burner step-down transformer fuses is blown, or that the field-installed high exhaust gas temperature switch is tripped. On all steam-fed units, the solution and refrigerant pumps are not started until the first stage generator pressure rises to 50.15mm HgA (0.97 PSIA). Typically, this causes a 30-second start sequence.

During "System Run" on steam units, the steam valve is prevented from unloading to less than 20% of unit capacity. The unit capacity percentage may not correspond to the steam valve position displayed with the **DISPLAY DATA** keypad key. The steam valve position displayed is the position of the valve with respect to fully closed and fully open. When the valve is fully closed, the position is 0%; when fully open, the position is 100%. A given unit could require 40% steam valve position to achieve

20% of unit capacity. On units equipped with Honeywell steam valves, the valve is prevented from unloading to less than 20% of unit capacity by a **limit switch** that is wired in series with the close winding of the valve actuator. The limit switch is part of the steam valve actuator. At unit shutdown, a relay on the **relay board** bypasses the limit switch and drives the valve fully closed. On units equipped with Leslie steam valves (EPROM version A.01F.08 and later), there is no limit switch. The **Minimum Allowed Loading** setpoint is set to a valve position that corresponds to 20% of unit capacity. This setpoint determines the lowest allowable steam valve position during unit run.

When the **UNIT** switch is pressed in **HEATING ONLY** mode (gas/oil units), the sequence is slightly different. The message displayed is

HEATING START SEQUENCE INITIATED

The hot water pump and burner start contacts are closed and the hot water flow switch is bypassed for the first 30 seconds of the start sequence. After a 30- to 90-second delay, the burner control closes the circuit between terminals 38 and 39 (burner on contacts) to signal the micro panel at terminals TB1-18 and the message

SYSTEM RUN - LEAVING HOT WATER CONTROL

is displayed. When a system shutdown occurs, these pumps are turned off coincident with the removal of the start signal. Any unit operating in **HEATING ONLY** mode, separate hot and chilled water flow switches are required regardless of the piping configuration. This allows the hot water flow switch opening to trip on a cycling rather than safety shutdown, eliminating the need for operator intervention to manually reset a safety shutdown.

When starting the standard "S" series units (without external heat exchanger—micro board program jumper JP2 removed), in **HEATING ONLY** mode, the operation is the same as above, except that the refrigerant, hot water and all solution pumps run. The solution pump is turned on coincident with

SYSTEM RUN - LEAVING HOT WATER CONTROL

being displayed. The refrigerant pump start is delayed for 10 minutes. On unit models 16SL through 19S, the spray solution pump is turned on after a 30- to 120-second delay (10 to 120 seconds with EPROM version A.01F.09 or later; as programmed by the **Spray Solution Pump Delay** setpoint). When a unit shutdown occurs, a 10-minute dilution cycle is performed. It terminates after 10 minutes, regardless of solution temperature. The hot water pump and all solution pumps run during the dilution cycle. If the chilled water pump is used in heating mode because there is no separate hot water pump, the hot water pump control contacts (TB4-87/88) must be wired in parallel with the chilled water pump contacts (TB4-44/45).

Operation of the high water temperature (HWT) cycling shutdown is similar to the low water temperature cycling condition in cooling mode. After cycling off due to HWT at 5°F above setpoint, the unit will not allow restart until the leaving hot water temperature falls to 10°F below setpoint. If the leaving hot water temperature setpoint is decreased while the unit is running, the HWT shutdown threshold becomes 155°F ("G" series units with standard heat exchanger), 175°F ("S" and "G" series with high temp heat exchanger), 145°F (standard "S" series without heat exchanger) for 30 minutes to eliminate nuisance trips. If the unit shuts down on other than HWT, the leaving hot water temperature will be equal to or less than the hot water temperature setpoint for unit restart. If not, the panel will initiate a cycling shutdown and display the status message

DAY - TIME - LVG WATER TEMP ABOVE SETPOINT

If the hot water flow switch opens while the unit is running, the unit shuts down on a cycling shutdown and

DAY - TIME - HW FLOW SWITCH - AUTOSTART

is displayed. The hot water pump control contacts (TB4-87/88) remain closed for 30 seconds in attempt to re-establish water flow.

During cooling or heating operation, the micro panel modulates the burner from 30 to 100% output by varying the 4-20mA signal. In **SERVICE** mode, the micro panel allows manual burner operation via its **LOAD**, **UNLOAD**, and **HOLD** keys. In the case of steam-fed units, however, the micro panel varies the load by pulsing the steam valve actuator inputs to control chiller capacity from 20 to 100%. The steam-fed unit is used for cooling only. All units can be manually controlled (**LOAD**, **UNLOAD**, **HOLD**) in **SERVICE** mode from the keypad. When a unit is commissioned, it is sometimes necessary to limit the maximum load. This is accomplished by entering the special access code to enter program mode. Via the load key, the Service Engineer can program the **Maximum Cooling Load** (for all units) and **Maximum Heating Load** (for gas/oil-fired units) each from 40% to 100%. The default value for both is 100%. When the unit is operating, if the maximum load is reached, the message displayed is

SYSTEM RUN - MAXIMUM COOLING

or

SYSTEM RUN - MAXIMUM HEATING

During operation, the first stage generator pressure, which is continuously monitored and displayed, provides a control function. A high pressure override, similar to the high pressure override feature of CodePaks, limits the main flame or steam valve opening to 30% whenever the threshold of 659.7mm HgA (12.76 PSIA) is reached. During this time, the panel displays

SYSTEM RUN – PRESS STATUS

and the warning relay contacts are closed. The **STATUS** key displays the message

HIGH PRESS OVERRIDE

This feature allows the chilled water (or hot water in heating mode) temperature control to be bypassed in order to keep the unit from cycling off. The warning relay contacts open when the **WARNING RESET** key is pressed in **LOCAL**, **REMOTE** or **SERVICE** mode; the message clears only if the pressure falls to 258.5mm HgA (5.0 PSIA) and subsequently the **WARNING RESET** key is depressed in **SERVICE** mode. If the first stage generator pressure continues to rise, however, the unit will perform a safety shutdown via the HP cutout switch at the preset value and, in cooling mode, display the message

SYSTEM SHUTDOWN – DILUTION – PRESS STATUS

The background (status) message will read

DAY – TIME – 1ST STAGE GEN PRESS

After completion of the dilution cycle, the message will read

SYSTEM SHUTDOWN – PRESS STATUS

In heating mode, the message displayed is

SYSTEM SHUTDOWN – PRESS STATUS

as the dilution cycle is not required. When the pressure falls to the reset value, with all other safety and cycling checks satisfied, the chiller can be manually restarted after pressing the unit switch to **STOP/RESET**.

A lower limit on entering condenser water temperature provides a warning message after a 30-minute bypass at unit start-up. For standard units, the minimum allowable threshold is 68°F; with the optional low entering condenser water temperature kit, the threshold is 59°F. In addition, an upper limit on entering condenser water temperature provides a warning message and limits the maximum load to 60%. The check is bypassed for the first 30 minutes of unit operation and the water temperature must exceed the specified limit for 10 minutes continuously. The maximum allowable entering condenser water temperature is programmable from 75° to 95°F. To program the value, the Service Engineer must enter the special access code and then **PROGRAM** mode. Press the **CONDENSER WATER TEMPS** key and enter the desired maximum entering condenser water temperature for which 100% load is allowable. The default value is 86°F.

Pull down demand limiting is a standard feature for all units (except those units connected to the optional FAX-

4500 Integrated Systems Network (ISN) through the RS-485 serial port). In **PROGRAM** mode, this function allows selection of the duration of the demand limit interval, the starting maximum steam valve position/burner signal, and the ending maximum steam valve position/burner signal. The programmable range is from 20 to 100% for steam units and from 30 to 100% for gas/oil-fired units; the allowable duration is from 0 to 255 minutes. Operation of this function is as follows: Each time the unit starts, a timer begins counting down the pull down interval. Unit loading/unloading, controlled by the automatic temperature control algorithm, is initially limited by the maximum programmed start value. For the remainder of the interval, the limit is the value determined by the difference between the starting and ending values multiplied by the time since starting divided by the total time interval selected. Thus, the actual limit linearly increases from start to end, allowing the unit to ramp load to limit energy input. During the pull down interval, pressing the **PULL DOWN DEMAND** key displays the actual load limit and the time remaining until timeout.

Units with YORK's optional FAX 4500 Integrated Systems Network (ISN) allow remote start/stop, remote reset of leaving chilled/hot water temperature, and remote steam/fuel limit control of the unit via the RS-485 serial port TB7. In addition, all unit information that is displayed on the micro panel is transmitted to the FAX 4500. Whenever the remote load limit function inhibits the automatic temperature control operation, the message

SYSTEM RUN – LEAVING CHILLED WATER CONTROL

or

SYSTEM RUN – LEAVING HOT WATER CONTROL

is replaced with the message

SYSTEM RUN – REMOTE LOAD LIMIT

Steam units have an additional feature which allows a remote hard-wired input signal on relay board terminals 82 and 1 to provide a **Remote Steam Limit** function. The standard signal accepted by the panel is a 1–11 second PWM signal which allows the limit to be set from 100 to 20% of the steam valve position. With the optional card file and reset card, the signal can be 4-20mA, 0–10 VDC, or a discrete contact closure. If the remote steam limit function inhibits the automatic leaving chilled water temperature control algorithm, the message

SYSTEM RUN – LEAVING CHILLED WATER CONTROL

is replaced with the message

SYSTEM RUN – REMOTE LOAD LIMIT

Both steam and gas/oil-fired units accept a 1–11 second PWM **Remote Temperature Reset** input signal at

digital input board terminal 19. This signal allows resetting the leaving water temperature setpoint to a maximum of 20°F above the operator-entered value (base). With the optional card file and reset card, the signal can be 4-20mA, 1–10 VDC, or a discrete contact closure.

On those units equipped with EPROM version A.01F.09 or later, the solution concentration is calculated as a function of the second stage leaving refrigerant temperature (RT12) and the first stage generator temperature (RT6). If the unit is running and the first stage generator temperature is at least 250°F, when the concentration load exceeds 66.0%, the message

WARNING – CONCENTRATION OVERRIDE

is displayed and unit loading is limited to minimum. The load limit will be removed if the concentration decreases to 65.0%. The message will remain until the **WARNING RESET** key is pressed in **SERVICE** mode. If the concentration continues to increase to 66.5%,

DAY – TIME – HIGH SOLUTION CONCENTRATION

is displayed and a safety shutdown is initiated. The % concentration can be displayed using the **FIRST STAGE GEN PRESS/TEMP** key if the unit is running and the first stage generator temperature is at least 250°F (and the concentration message display has been enabled by a qualified service technician using the “Special Setpoints and Programming Procedures” section of service manual 155.17-M2). Concentration related messages, inhibits and shutdowns are not displayed or performed in **HEATING ONLY** mode.

All units have a “Concentration Calculator” feature that allows solution concentration to be calculated using the Control Center keypad. The operator enters a bromide solution temperature and then enters either a saturation temperature or refrigerant pressure. The % solution concentration is then automatically calculated and displayed.

DILUTION CYCLE (AUTOMATIC)

In cooling mode, the dilution cycle occurs at most shutdowns. The dilution cycle is designed to prevent crystallization of the lithium bromide strong solution. During the dilution cycle the solution, refrigerant, chilled and condenser water pumps are on. Also, the solution dilution temperature is monitored. If the solution temperature is <91°F when the unit shuts down, the dilution is terminated after 30 minutes. Otherwise, the dilution is terminated after a minimum of 10 minutes or until the solution temperature has decreased to <136°F, whichever takes longer. If the chiller/heater is shut down due to the **solution or refrigerant pump overloads** or **thermal switches**, **chilled water flow switch**, or **low refrigerant temperature**, the dilution cycle will be bypassed. Opening of any of the previously listed contacts (in bold type) during the dilution cycle also disables the dilution

cycle. If the solution or refrigerant thermal switches reclose, the dilution cycle is initiated (one time only) if the solution temperature is above 136°F. If, when the solution or refrigerant thermal or overload contacts close, the solution dilution temperature is below 136°F, the unit will initiate a safety shutdown with the background message

DAY – TIME – PO – CHK SOL'N LEVEL – ABS & GEN

After adjusting the required solution levels, the unit can be restarted by placing the **UNIT** switch in **STOP/RESET** position, then pressing the **WARNING RESET** key in **SERVICE** mode and then initiating a start. If the low refrigerant temperature switch or sensor is the cause of shutdown, the chilled water pump will continue to run; when the low refrigerant temperature switch recloses or sensor rises to $\geq 5^\circ\text{F}$ above the temperature at which it cut out, a dilution cycle will be initiated if the solution dilution temperature is above 136°F; if the temperature is below 136°F, the unit will initiate a safety shutdown; the background message will be

DAY – TIME – LRT – CHK SOL'N LEVEL – ABS & GEN

and the chilled water pump will turn off.

After adjusting the required solution levels, the unit can be restarted by placing the **UNIT** switch in **STOP/RESET** position, then pressing the **WARNING RESET** key in **SERVICE** mode and then initiating a start. Following a chilled water flow switch shutdown, a dilution cycle will be initiated if the flow switch recloses and the solution dilution temperature is above 136°F. If the temperature is below 136°F, the unit will initiate a safety shutdown; the background message will be

DAY – TIME – FLS – CHK SOL'N LEVEL – ABS & GEN

After adjusting the required solution levels, the unit can be restarted by placing the **UNIT** switch in **STOP/RESET** position, then pressing the **WARNING RESET** key in **SERVICE** mode and then initiating a start.

AUTOMATIC DILUTION CYCLES AFTER POWER FAILURES

Whether or not an automatic dilution is performed after a power failure depends upon (a) whether the unit was running when the power failure occurred; (b) the solution temperature when power is restored; (c) whether or not the unit is configured for “Manual Restart After Power Failure” or “Auto Restart After Power Failure”; and (d) the duration of the power failure.

Automatic dilution cycles can only be performed if the unit was running when the power failure occurred and the solution temperature is greater than 136°F when power is restored.

Manual Restart After Power Failure

1. Regardless of the duration of the power failure, if the solution temperature is $<136^{\circ}\text{F}$ when power is restored, no dilution is performed. The unit locks out on a safety shutdown with the following message displayed:

DAY – TIME – PF – CHK SOL'N LEVEL

2. Regardless of the duration of the power failure, if the solution temperature is $>136^{\circ}\text{F}$ when power is restored, a dilution is performed. At the completion of the dilution, the unit can be restarted after a manual reset is performed.

Auto Restart After Power Failure

1. If the power failure duration is <1 minute and the solution temperature is $<136^{\circ}\text{F}$ when power is restored, no dilution is performed. The unit locks out on a safety shutdown with the following message displayed:

DAY – TIME – PF – CHK SOL'N LEVEL – ABS & GEN

If the power failure duration is <1 minute and the solution temperature is $>136^{\circ}\text{F}$ when power is restored, the unit automatically restarts without performing a dilution.

2. If the power failure duration is >1 minute and the solution temperature of $<136^{\circ}\text{F}$ when power is restored, no dilution is performed. The unit locks out on a safety shutdown with the following message:

DAY – TIME – PF – CHK SOL'N LEVEL – ABS & GEN

If the power failure duration is >1 minute and the solution temperature is $>136^{\circ}\text{F}$ when power is restored, a dilution is performed and at the completion of the dilution the unit automatically restarts.

If the unit cycles off due to the condenser water flow switch, the unit will begin the dilution cycle, regardless of the solution dilution temperature. Simultaneously, a software timer begins to time the dilution cycle; at the end of one hour, the dilution cycle is automatically terminated to prevent solution pump cavitation.

"S" series units that are not equipped with the optional high temperature heat exchanger also perform a 10-minute dilution cycle at all shutdowns when they are operating in **HEATING ONLY** mode (micro board program jumper JP2 removed). During the dilution, the hot water pump and all solution pumps run. When 10 minutes have elapsed, the dilution is terminated regardless of the solution temperature and all pumps are turned off.

"Limited Dilution" cycles can be performed during power failures on those units equipped with a **Standby Power Supply**. Refer to "Limited Dilution Cycles" section that follows.

DILUTION (MANUAL)

A dilution cycle can be manually initiated any time the unit is shut down as long as the shutdown was not caused by refrigerant pump thermal switch/overload, solution pump thermal switch/overload, low refrigerant temperature or chilled water flow switch. After the cycle has been manually initiated, it will operate like the automatic cycle listed above.

A dilution cycle is manually initiated as follows:

1. Place **UNIT** switch in **STOP/RESET** position.
2. Place Control Center in **SERVICE** mode. (Refer to procedure under "Operating Modes.")
3. Press and hold the **PUMP STATUS** key until this message is displayed:

MANUAL DILUTION CYCLE – OFF

Immediately release the **PUMP STATUS** key. (The "Display Hold" feature is automatically engaged when using the **PUMP STATUS** key in service mode. It will remain engaged until the **DISPLAY HOLD** key is pressed or 10 minutes have elapsed, whichever occurs first.)

4. Press and release **MANUAL PUMP** key. This message is displayed:

MANUAL DILUTION CYCLE – ON

When the dilution cycle is manually initiated (ON), it will automatically terminate when the dilution cycle is complete. However, it can be stopped at any time during the cycle by pressing and releasing the **MANUAL PUMP** key. This message is then displayed:

MANUAL DILUTION CYCLE – OFF

LIMITED DILUTION CYCLES (AUTOMATIC)

Since dilution cycles cannot be performed during power failures, crystallization could occur during long power failures. "Limited Dilution" cycles can be performed during utility power failures using an emergency generator (or other standby power supply) to power only the Millennium Control Center and the solution pumps as described below. The equipment required to perform this function must be selected in accordance with the power requirements of the YPC Absorption Unit. A description of the required hardware, interface wiring, fuse and generator size requirements is contained in YORK applications data manual, Form 155.17-AD1.

When a utility power failure occurs, an **automatic transfer switch** (ATS) transfers the power source from utility power to standby power source (generator). Simultaneously, two sets of normally open contacts that are part of the ATS close and remain closed for the duration of the utility power failure; one set starts the generator,

the other set signals the Millennium Control Center (at digital input board TB2-95) that a standby power supply is on-line and a limited dilution should be performed. (While the contacts are closed, the unit cannot be started and normal unit operation is inhibited.) The Millennium Control Center performs a limited dilution by running only the solution pumps. While the limited dilution is in progress,

DAY - TIME - SOL'N PUMP ONLY DILUTION CYCLE

is displayed when the **STATUS** key is pressed. The limited dilution will terminate after 4 hours have elapsed unless interrupted by restoration of utility power, detection of condenser water flow (see below) or the solution pump overloads open. When the limited dilution cycle has completed, and the contacts connected to TB2-95 are still closed, this message is displayed:

DAY - TIME - STANDBY POWER - UNIT LOCKOUT

NOTE: Units must be equipped with Digital Input Board 031-01621-001 (standards units) or 031-01621-002 (VDE units) to have TB2-95. Previous Digital Input Board 031-00935-000 does not have TB2-95.

If the unit was not running when the transfer to standby power occurred,

DAY - TIME - STANDBY POWER - UNIT LOCKOUT

is displayed and no limited dilution is performed. If the solution dilution temperature is <136°F when the transfer to standby power occurs,

DAY - TIME - LD - CHK SOL'N LEVEL - ABS & GEN

is displayed and the limited dilution is not performed.

During the limited dilution, no condenser water flow is allowed. If condenser water flow is detected, through the closing of the flow switch, the limited dilution cycle is terminated and

DAY - TIME - FLS - LIMITED DILUTION OVERRIDE

is displayed. If condenser water flow ceases, the limited dilution will resume if the solution dilution temperature is >136°F. Otherwise,

DAY - TIME - LD - CHK SOL'N LEVEL - ABS & GEN

is displayed and the unit is locked out until the **WARNING RESET** key is pressed in **SERVICE** mode with the **UNIT** switch in **STOP/RESET** position.

If any of the solution pumps overloads open during the limited dilution cycle,

DAY - TIME - LD - CHK SOL'N LEVEL - ABS & GEN

is displayed, the limited dilution is terminated, and the unit is locked out until the **WARNING RESET** key is pressed in **SERVICE** mode with the **UNIT** switch in the **STOP/RESET** position.

If a limited dilution is in progress and the automatic transfer switch (ATS) detects that utility power has been restored, it transfers the power source from standby power to utility power, and the ATS contacts connected to digital input board TB2-95 open. This causes a standard full dilution to be performed depending on whether the unit is configured for "Manual Restart After Power Failure" or "Auto Restart After Power Failure" and the duration of the utility power failure. To explain: If the unit is configured for "Manual Restart After Power Failure" a full standard dilution is performed regardless of the solution dilution temperature. If the unit is configured for "Auto Restart After Power Failure" and the utility power failure duration was >1 minute, a standard full dilution is performed, followed by an automatic unit restart; if the utility power failure was <1 minute, the unit automatically restarts without performing a standard full dilution cycle, regardless of the solution temperature.

If a limited dilution cycle is completed (4 hours) during a standby power condition, no full standard dilution is performed when the automatic transfer switch transfers the power source back to utility power (utility power is restored).

PURGE (MANUAL)

The following manual purge operation can be performed on all units except those equipped with EPROM version A.01F.09 (and later) that are equipped with the Automatic Purge Hardware (I/O expansion board program jumper JP1 removed). Units equipped with EPROM version A.01F.09 (and later) that are also equipped with the Automatic Purge Hardware (I/O expansion board program jumper JP1 removed), can perform the manual purge operation described below in "Purge (Automatic)."

The purge pump can be manually controlled from the YPC Control Center keypad to perform a manual purge operation. The purge pump can be turned on and off in **LOCAL**, **REMOTE** or **SERVICE** mode whether the unit is running or not.

To manually operate the purge pump, proceed as follows:

CAUTION: To reduce the risk of injury, do not operate the pump with the belt guard removed!

1. Press and release the **PUMP STATUS** key. (The "Display Hold" feature is automatically engaged when using the **PUMP STATUS** key. It will remain engaged until the **DISPLAY HOLD** key is pressed or 10 minutes have elapsed, whichever occurs first.) One of the following messages is displayed

PURGE PUMP - ON

or

PURGE PUMP - OFF

indicating that the purge pump is running or not running.

2. Press and release the manual pump key. If the purge pump was ON, it will be turned OFF. If it was OFF, it will be turned ON. Each time the key is pressed, the displayed message will change from

PURGE PUMP – ON

to

PURGE PUMP – OFF

or vice versa.

While the purge pump is ON, the manual purge operation can be performed as detailed in 155.17-NM1.

After the purge pump runs for at least 10 minutes continuously, the 7-day purge counter and the unit lifetime purge counter increment by 1 count when the pump turns off. The 7-day purge counter and the total (lifetime) purge counter are displayed via the **PURGE CYCLE COUNTER** display key.

There are two purge counters employed to count manual purges. See below.

PURGE (AUTOMATIC)

Units equipped with EPROM version A.01F.09 and later and also equipped with Automatic Purge Hardware have 2 modes of purge operation as follows: (Refer to “Programming the YPC Control Center” section of this book to select the desired mode.)

1. Auto Tank Purge
2. Manual Purge

If the unit is equipped with the Automatic Purge Hardware, I/O expansion board program jumper JP1 must be removed. The Auto Purge Hardware consists of:

PT3	Purge Pump Pressure Transducer
PT4	Purge Tank Pressure Transducer
1SOL	Purge Tank Solenoid Valve
2SOL	Purge Pump Solenoid Valve

AUTO TANK PURGE

If **AUTO TANK PURGE** mode is selected, the purge operation is completely automatic. No operator intervention is required. It operates whether the unit is running or not as follows: When the purge tank pressure (PT4) increases to 60mm HgA, the purge pump is turned on and 10 to 38 seconds later the purge pump solenoid valve (2SOL) opens. When the purge pump pressure (PT3) decreases to 15mm HgA, the purge tank solenoid valve (1SOL) opens. After allowing the pressures to settle for 60 seconds, the purge tank pressure (PT4) is stored in memory and a 1-minute timer is started. When the timer has elapsed, if the purge tank pressure (PT4) is greater than or equal to the stored value, the purge tank solenoid valve (1SOL) and purge pump solenoid valve (2SOL) are closed, the purge pump is turned off,

WARNING – AUTO PURGE FAILURE

is displayed on the keypad display and **AUTO TANK** purge defaults to **MANUAL** purge operation. This 1-minute period is re-initialized at each timeout and the pressure check is performed for the duration of the purge operation. However, if the purge tank pressure (PT4) decreased in the 1-minute period after the purge pump pressure (PT3) decreased to 15mm HgA, the purge operation continues. When the purge tank pressure (PT4) decreases to 30mm HgA, the purge tank solenoid valve (1SOL) and purge pump solenoid valve (2SOL) are closed and the 7-day auto purge counter and lifetime total auto purge counter each increment by 1 count. Then, 15 minutes later, the purge pump is turned off and the purge operation is complete.

If the purge pump solenoid valve (2SOL) has been energized (open) for at least 1 minute during the purge operation, and the purge pump pressure (PT3) increases to greater than 100mm HgA, the purge tank solenoid valve (1SOL) and purge pump solenoid valve (2SOL) are closed, the purge pump is turned off after a 65-second delay to allow the purge pump solenoid valve to fully close,

WARNING – PRG PMP FAIL; MAN CLOSE VP2, VP5

is displayed and **AUTO TANK** purge defaults to **MANUAL** purge operation. This is indicative of a purge pump failure. The operator should manually close valves VP2 and VP5. Manual turnoff of the purge pump is prevented during the 65-second pump turnoff delay. If someone attempts to manually turn off the purge pump before the 65 seconds have elapsed,

PURGE PUMP VALVE CLOSING

is displayed when the **PUMP STATUS** key is pressed.

If the purge pump is *not* running and the purge pump pressure (PT3) increases to greater than 100mm HgA, the purge tank (1SOL) and purge pump (2SOL) solenoid valves are closed, the purge pump is turned on,

WARNING – 2SOL FAIL; MANUAL CLOSE VP2, VP5

is displayed, and **AUTO TANK** purge defaults to **MANUAL** purge operation. This is indicative of a purge pump solenoid valve (2SOL) failure. The purge pump continues to run until manually turned off using the **PUMP STATUS** and **MANUAL PUMP** keypad keys as follows:

1. Press **PUMP STATUS** key. The following message is displayed:

CLOSE VP2, VP5; PRESS ‘MANUAL PUMP’

2. Operator should close VP2 and VP5.

3. Press **MANUAL PUMP** key. The purge pump turns off and this message is displayed:

PURGE PUMP – OFF – MANUAL PURGE

4. Press **DISPLAY HOLD** key. The normal foreground message is displayed.

If the purge tank transducer (PT4) or purge pump transducer (PT3) indicates a pressure of <0.0mm HgA continuously for 25 seconds, the following message appears on the keypad display:

WARNING – PURGE TRANSDUCER ERROR

While **AUTO TANK** purge is selected, the purge pump cannot be manually operated. If the operator attempts to manually run the purge pump,

PURGE PUMP – OFF – AUTO TANK PURGE or

PURGE PUMP – ON – AUTO TANK PURGE

is displayed when the **PUMP STATUS** key is pressed.

If 6 or more automatic purges occur in 7 days,

WARNING – EXCESS PURGE

is displayed on the keypad display while the unit runs. The “Excess Purge” check is disabled during the first 150 hours of unit operation since more frequent purging of newly-commissioned units is common, especially if the unit was shipped with a nitrogen charge.

MANUAL PURGE

In **MANUAL PURGE** operation, although the purge tank solenoid valve and purge pump solenoid valve are automatically controlled, the operator must manually operate the purge pump. Manual purge operation will be enabled whenever:

- (a) an “Auto Purge Failure” warning, “Purge Pump Failure” warning, or 2SOL failure warning occurs in **AUTO TANK** purge mode or
- (b) **MANUAL PURGE** mode is selected.

If the purge tank transducer (PT4) or purge pump transducer (PT3) indicates a pressure of <0.0mm HgA continuously for 25 seconds, the following message is displayed:

WARNING – PURGE TRANSDUCER ERROR

To start manual purge:

1. Press **PUMP STATUS** keypad key until

PURGE PUMP – OFF – MANUAL PURGE

is displayed. The “Display Hold” feature is automatically engaged.

2. Press **MANUAL PUMP** key. The message

PURGE PUMP – ON – MANUAL PURGE

is displayed. The purge pump starts. After 2 minutes, the purge tank solenoid valve (1SOL) and purge pump solenoid valve (2SOL) open.

To stop manual purge:

1. Press **PUMP STATUS** key until

PURGE PUMP – ON – MANUAL PURGE

is displayed. The “Display Hold” feature is automatically engaged.

2. Press **MANUAL PUMP** key. If the pump has been running less than 2 minutes (purge tank and purge pump solenoid valves not opened yet), the purge pump is turned off and the message

PURGE PUMP – OFF – MANUAL PURGE

is displayed. If the purge pump has been running for greater than 2 minutes, the purge tank solenoid valve (1SOL) and purge pump solenoid valve (2SOL) close. The message

PURGE PUMP VALVE CLOSING

is displayed for 65 seconds and when the 65 seconds elapse, the purge pump is turned off and

PURGE PUMP – OFF – MANUAL PURGE

is displayed. The **MANUAL PURGE** operation is then complete. If the **MANUAL PURGE** operation continued for more than 10 minutes, the 7-day manual purge counter and lifetime total manual purge counter each increment by 1 count.

3. Press **DISPLAY HOLD** key. The normal foreground message is displayed.

PURGE COUNTERS

There are several different purge counters. The actual purge counter used on any unit is determined by the EPROM version and whether the unit is equipped with the Automatic Purge Hardware (I/O expansion board program jumper JP1 removed).

If the unit is equipped with the Automatic Purge Hardware (I/O expansion board program jumper JP1 is removed) and EPROM version A.01F.09 (or later) there are two **7-DAY PURGE COUNTERS**, two **TOTAL (LIFETIME) PURGE COUNTERS**, and an **EXCESS PURGE COUNTER**. The **7-DAY MANUAL PURGE COUNTER** accumulates the number of manual purges (if purge

pump runs at least 10 minutes continuously) that have occurred in the last 7 days; the **7-DAY AUTOMATIC PURGE COUNTER** accumulates the number of automatic (auto tank) purges that have occurred in the last 7 days. Each day at 12:00 midnight, the oldest day's count is deleted from the 7-day count. The **TOTAL MANUAL PURGE COUNTER** accumulates the total number of manual (if purge pump runs at least 10 minutes continuously) purges that have occurred over the lifetime of the unit. The **TOTAL AUTO PURGE COUNTER** accumulates the total number of auto tank purges that have occurred over the lifetime of the unit. The **EXCESS PURGE COUNTER** increments every time an automatic (auto tank) purge occurs. When the count reaches 6 within the last 7 days, warning contacts TB4–89/90 on relay board close and

WARNING – EXCESS PURGE

is displayed if the unit is running. When the operator presses the **WARNING RESET** key in **SERVICE** mode, the excess purge counter is reset to zero and will begin to accumulate automatic purges as they occur. The oldest day's count is automatically deleted from the total (after 7 days have elapsed) each day at 12:00 midnight. Because frequent purging of a new unit is common, the excess purge counter is inhibited during the first 150 hours of operation. The purge counters can be displayed by pressing the **PURGE CYCLE COUNTER** key. (The excess purge counter cannot be displayed.) The following messages will scroll on the display. Each will be displayed for 2 seconds while the key is pressed.

LAST 7 DAYS = XXX; TOTAL MAN PURGES = XXXXX

▲
Total manual purges
in the last 7 days

▲
Total manual purges to date
over lifetime of unit

LAST 7 DAYS = XXX; TOTAL AUTO PURGES = XXXXX

▲
Total auto tank purges
in the last 7 days

▲
Total auto tank purges to date
over lifetime of unit

If the unit is not equipped with EPROM version A.01F.09 (or later) or if not equipped with the Automatic Purge Hardware (I/O expansion board program jumper JP1 installed), there is a **7-DAY MANUAL PURGE COUNTER** and a **TOTAL MANUAL PURGE COUNTER**. They operate as described above.

If the micro board or Real Time Clock (RTC) chip (IC-U16 on micro board) is replaced, the accumulated counts in all the above purge counters will be lost. Therefore, prior to replacing either of these components, the service technician should note the total count in all counters. After the component has been replaced, the service technician should enter or reset the counter values using the "Special Programming Procedures" section in the service manual, Form 155.17-M2.

OPERATION FLOW CHART

UNIT OPERATION

GAS/OIL-FIRED COOLING MODE (Equipped with Automatic Purge System)

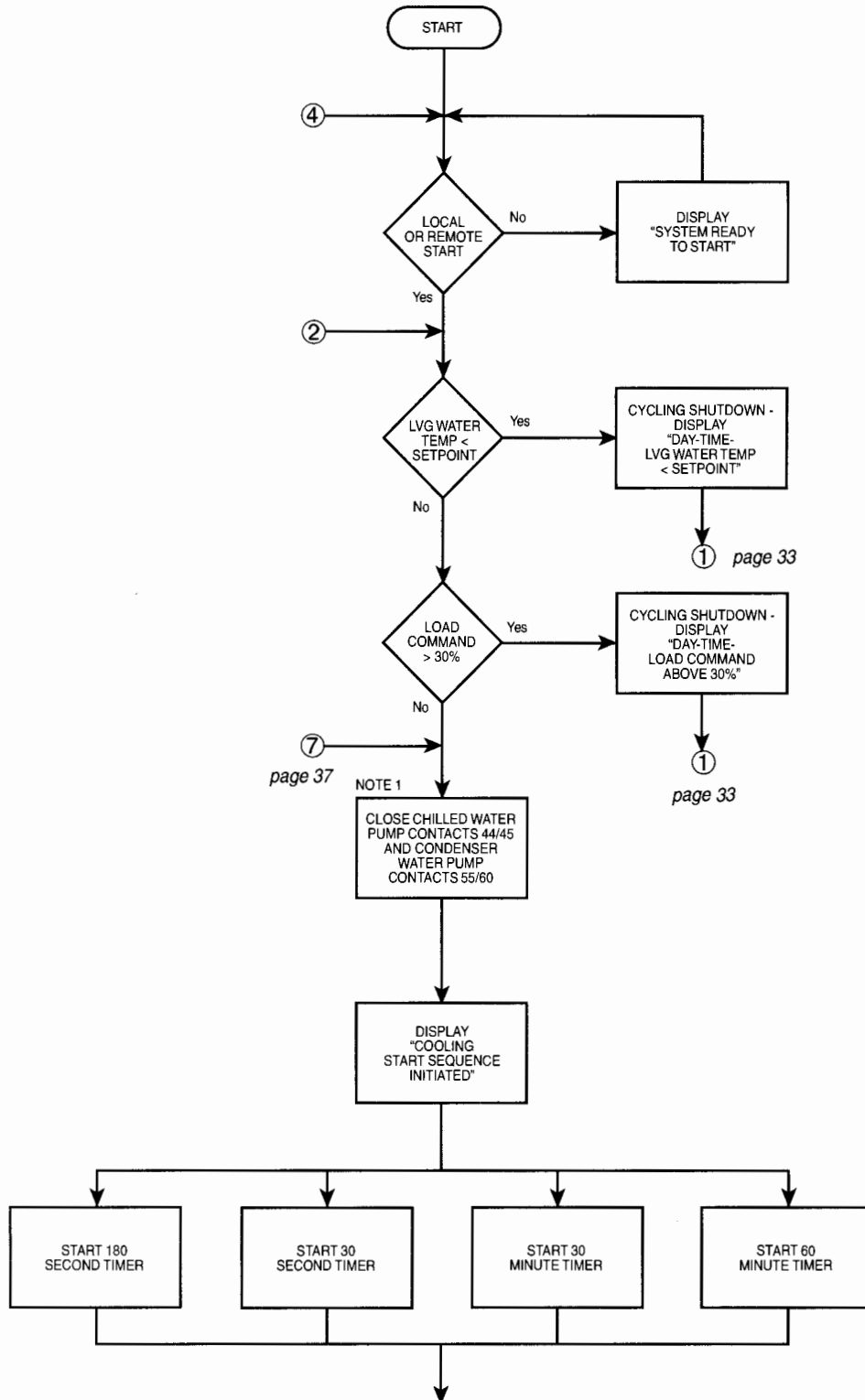

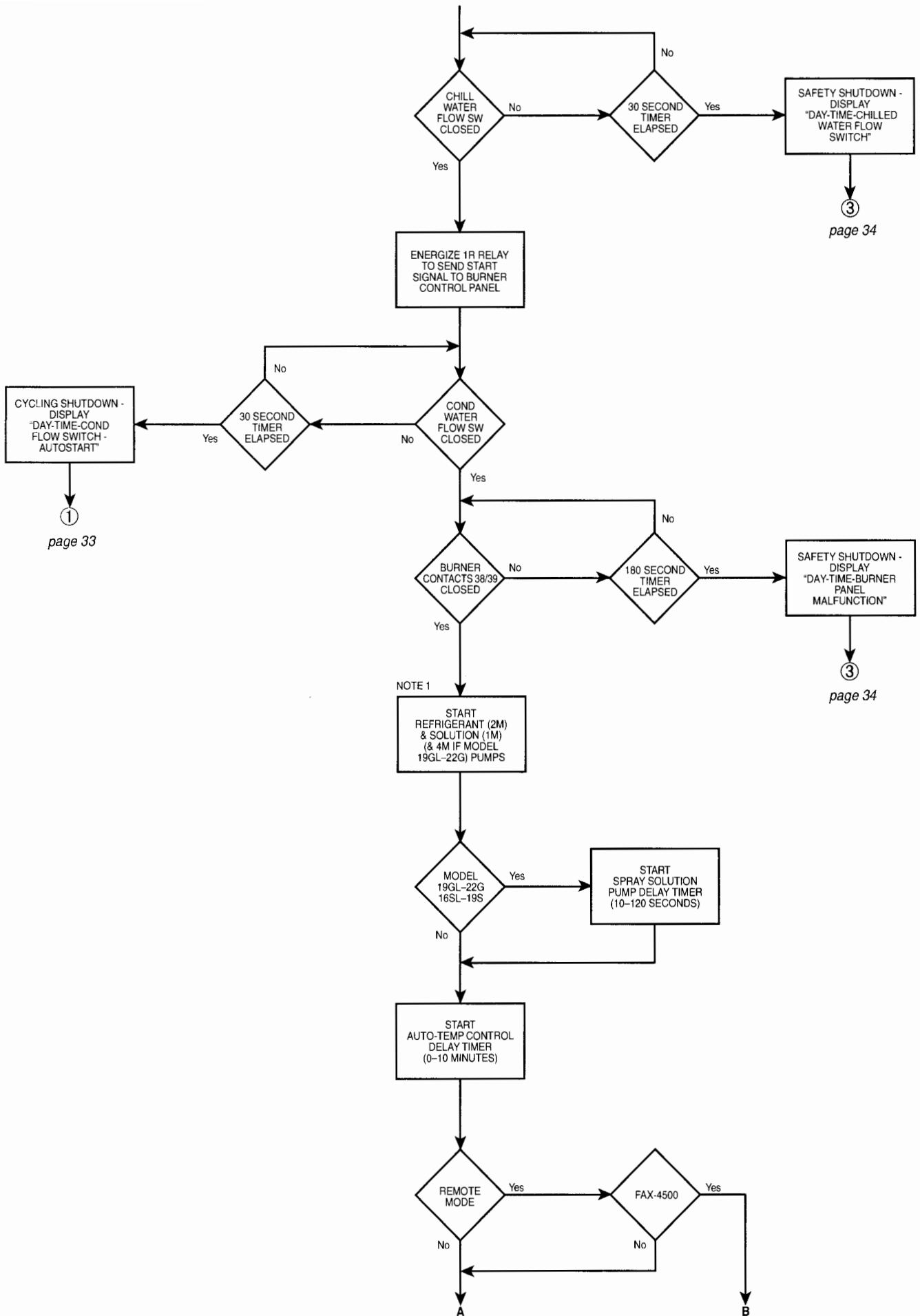

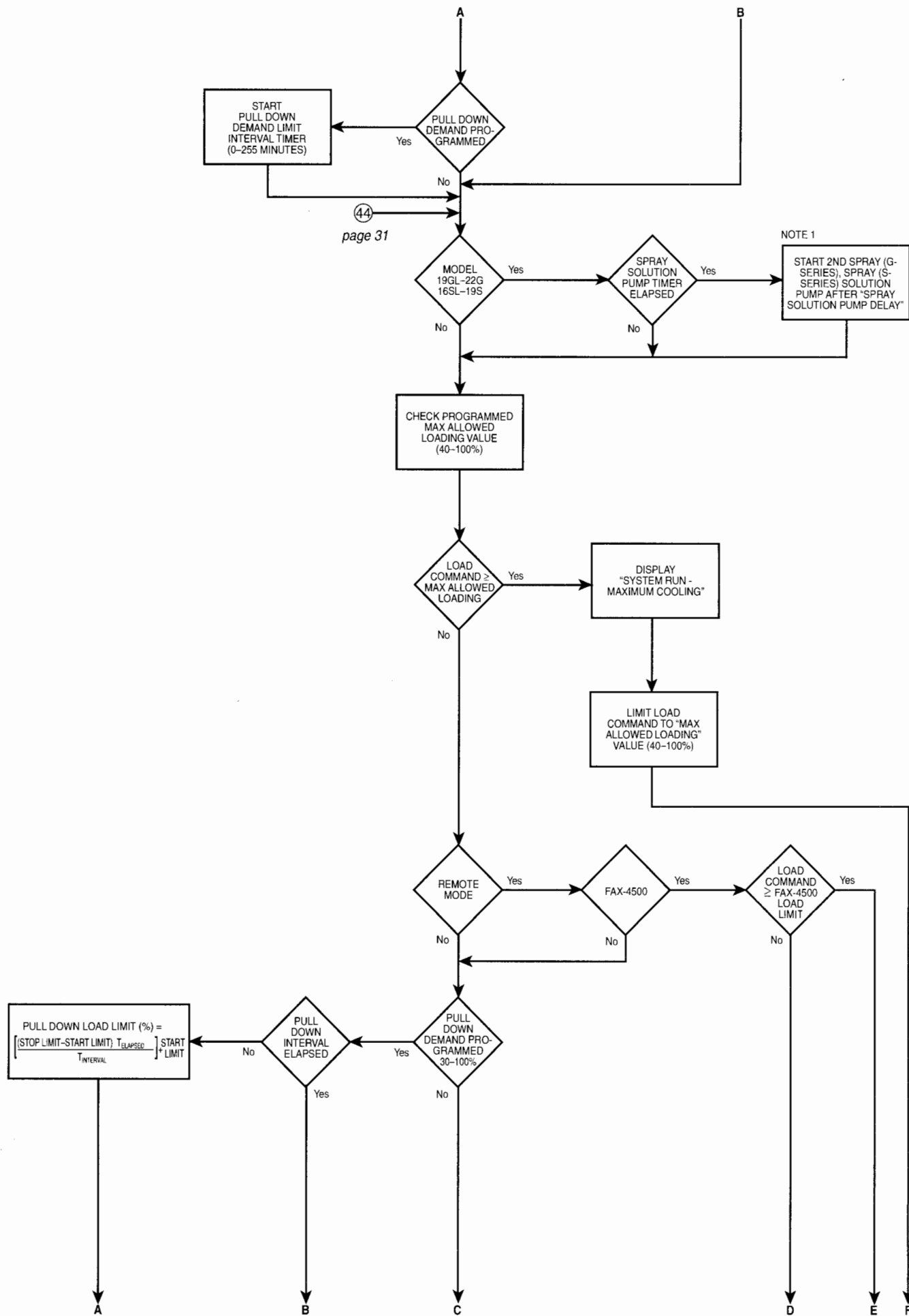

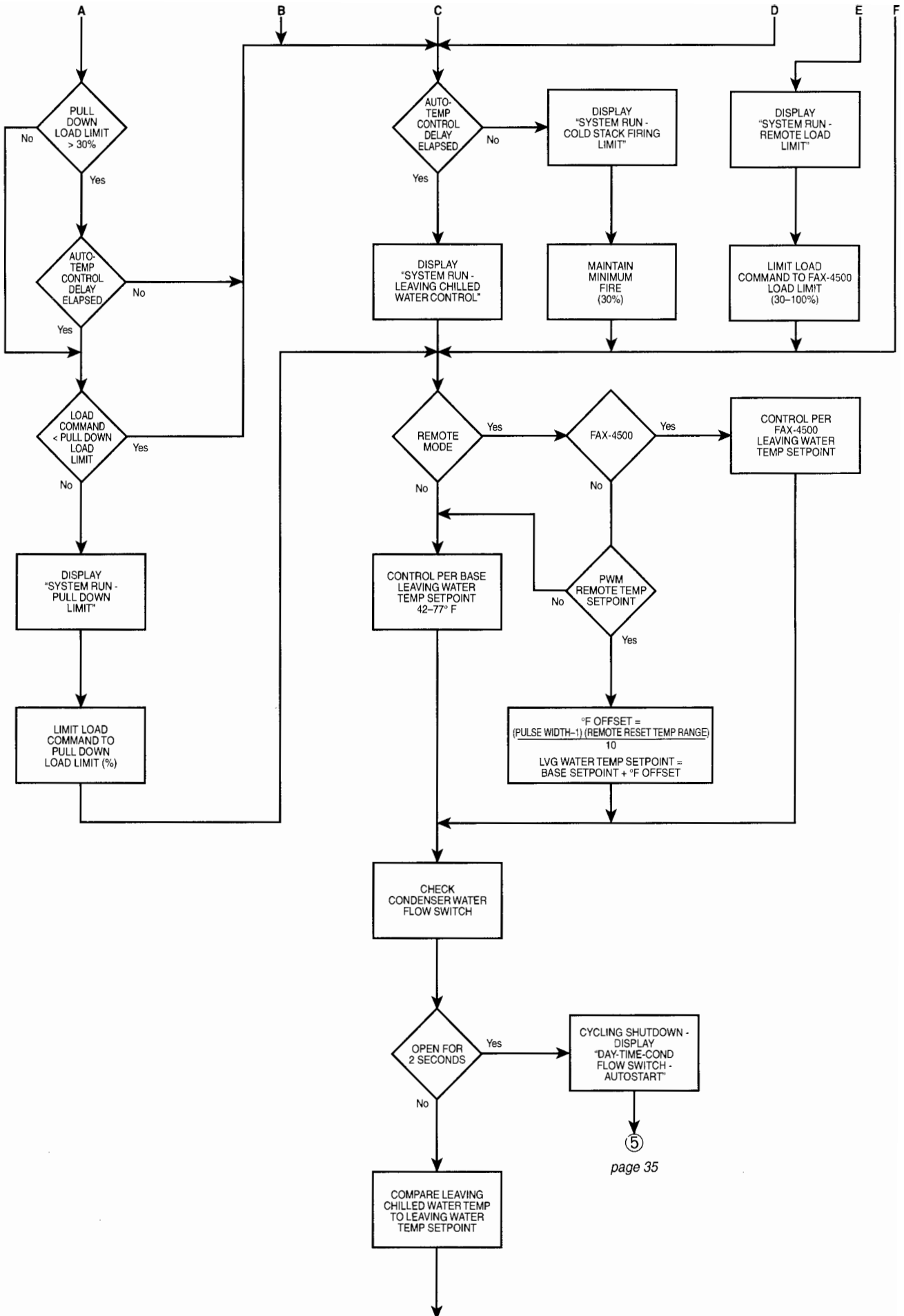

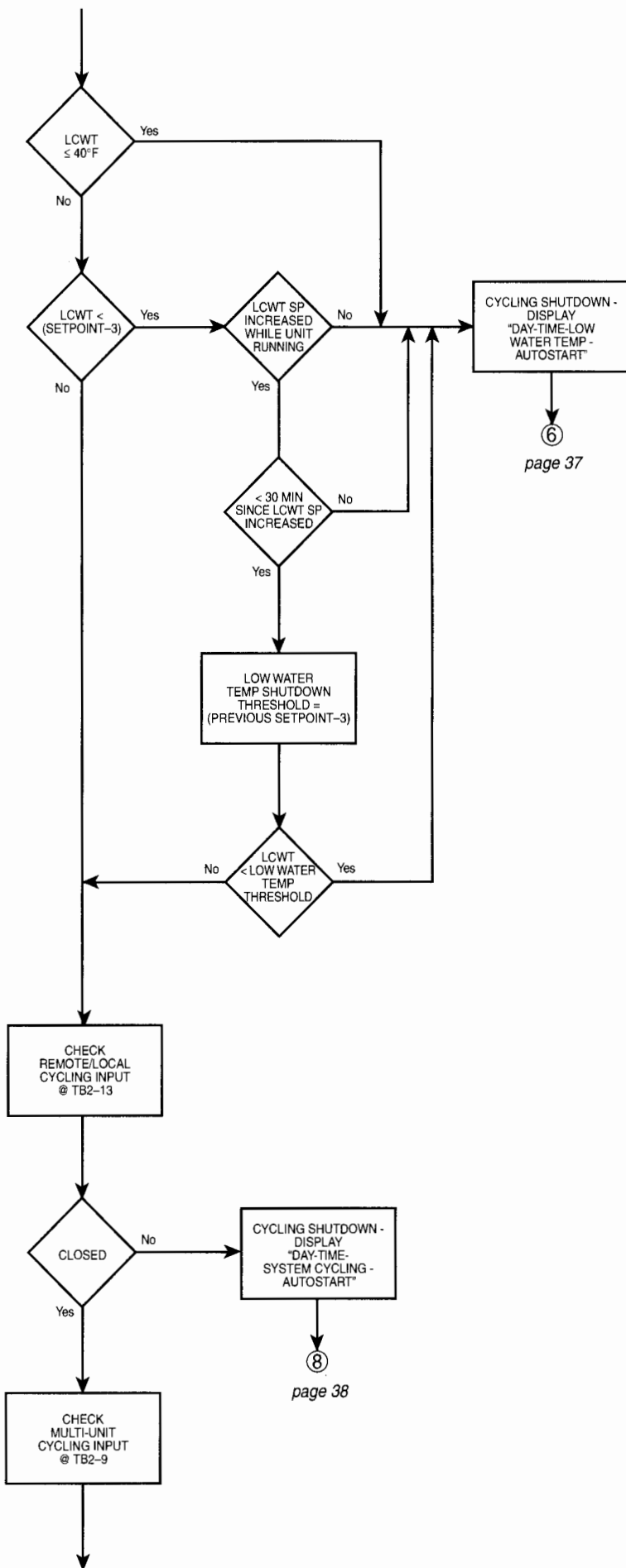

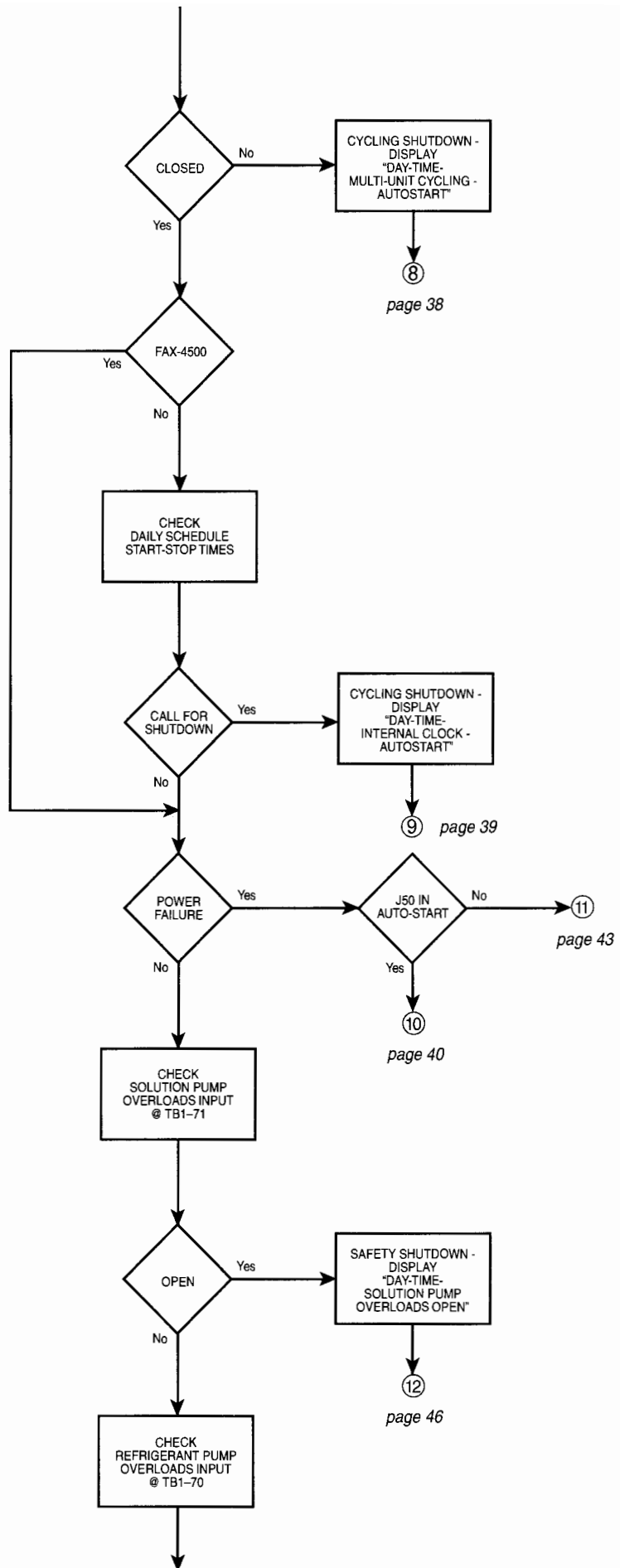

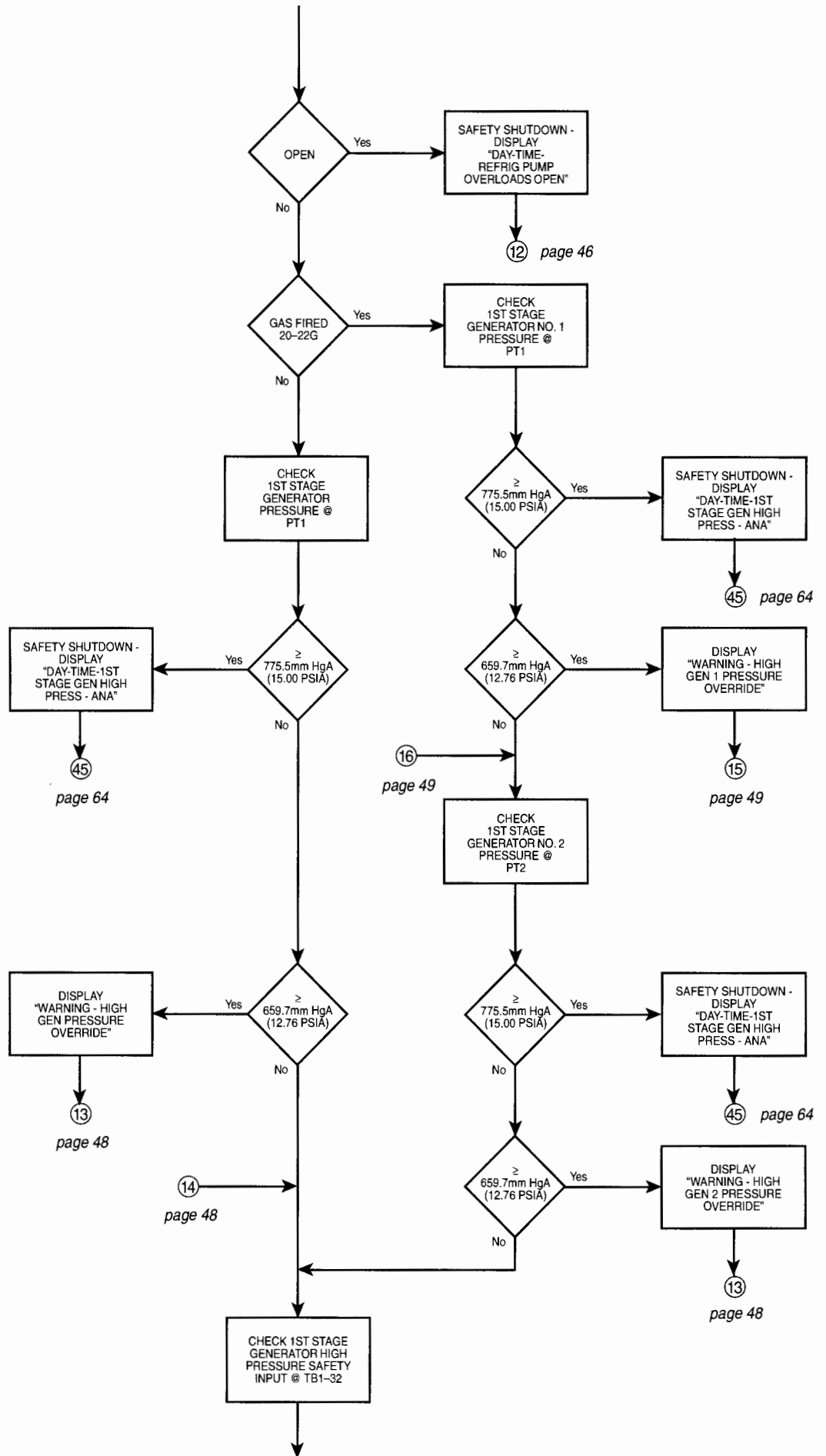

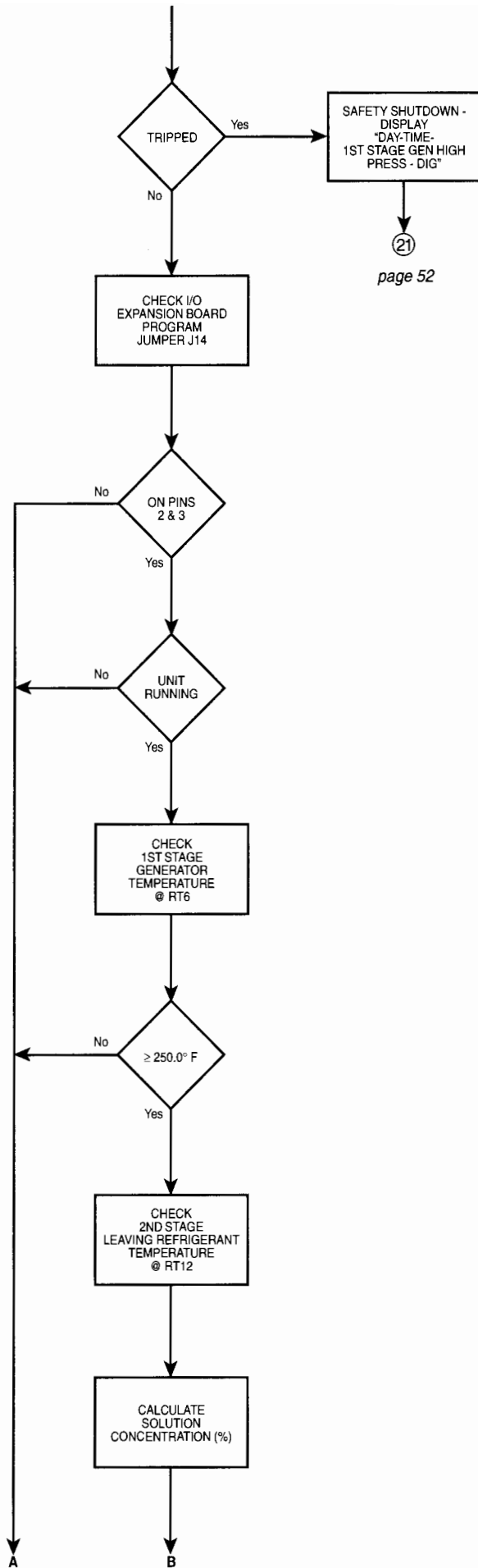

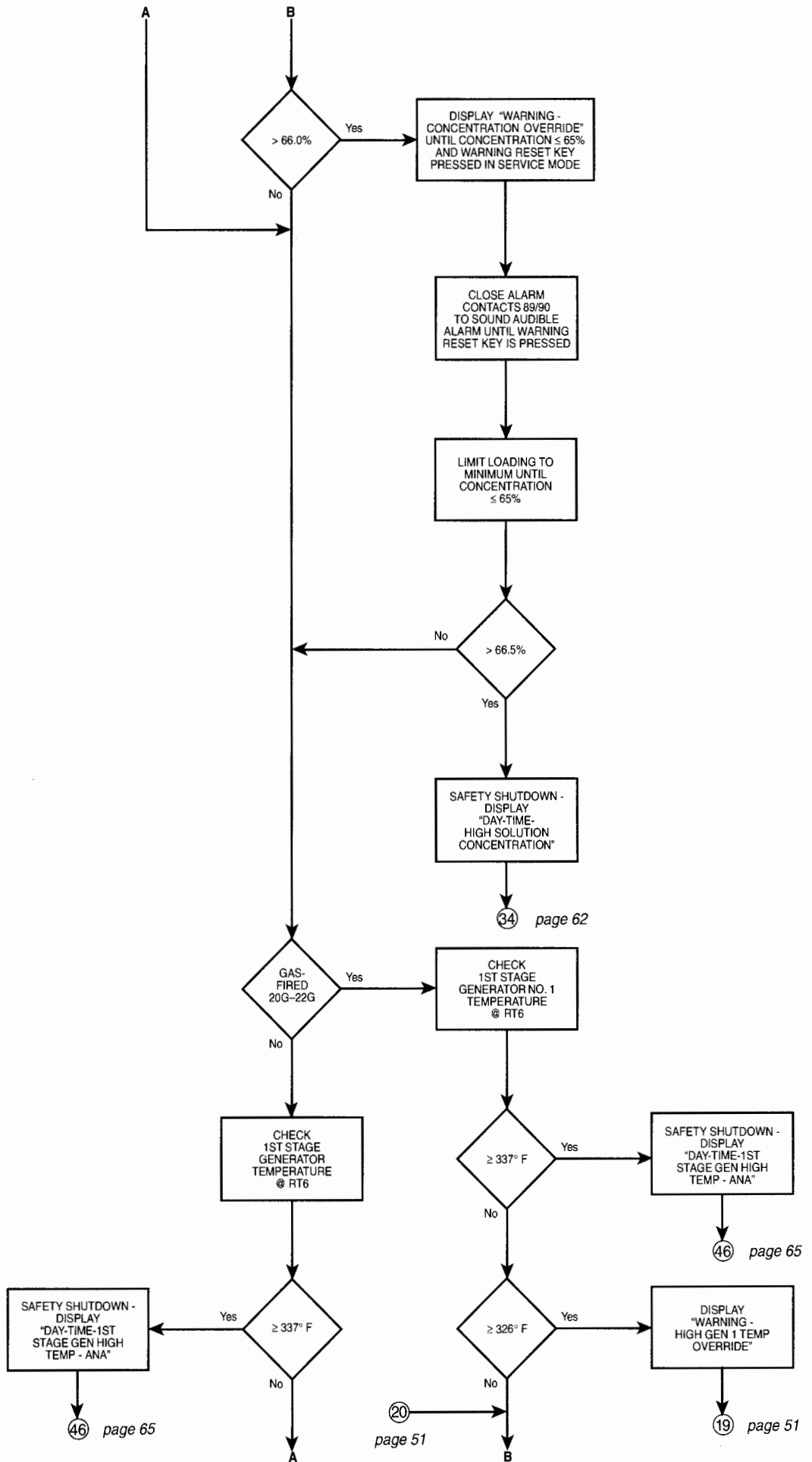

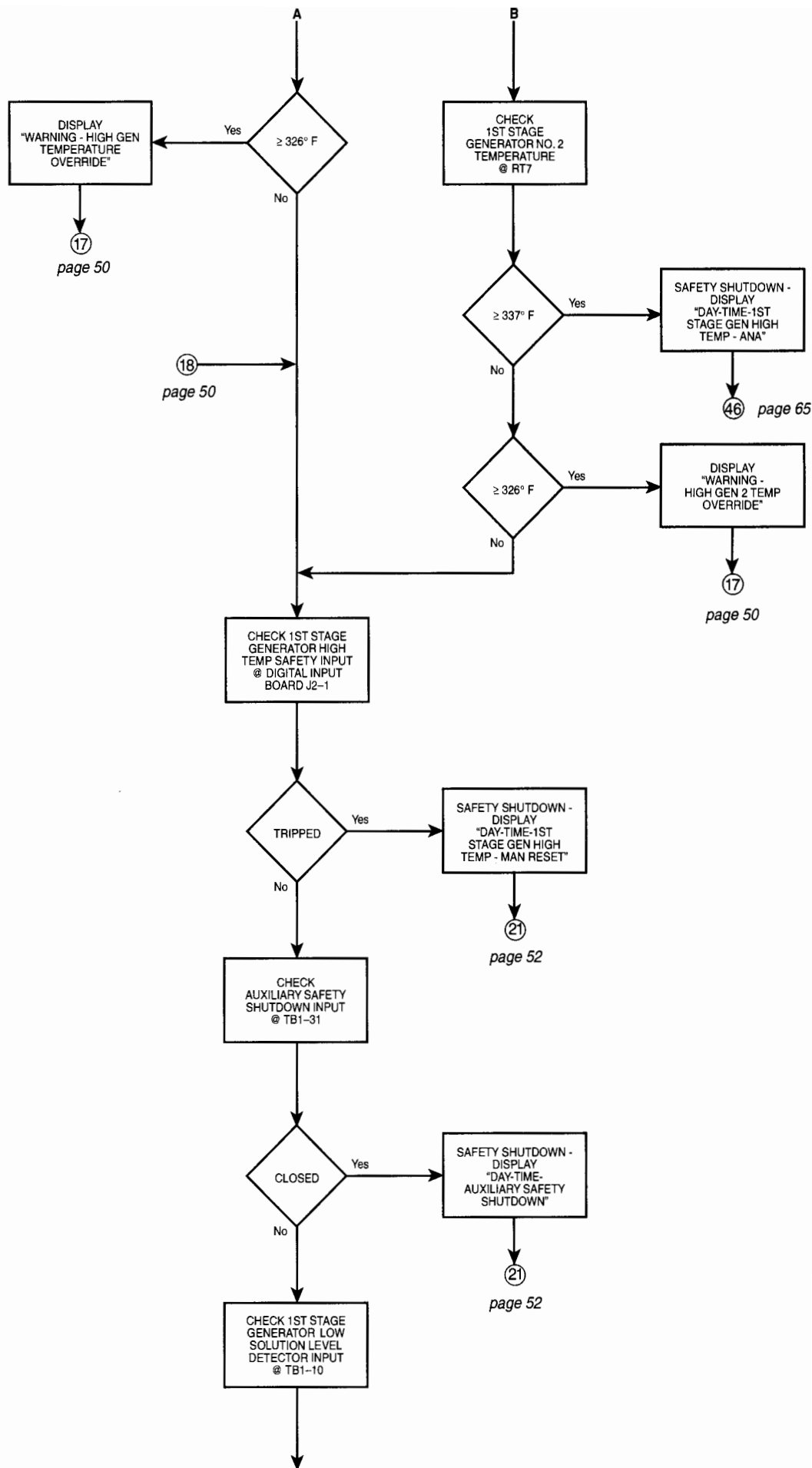

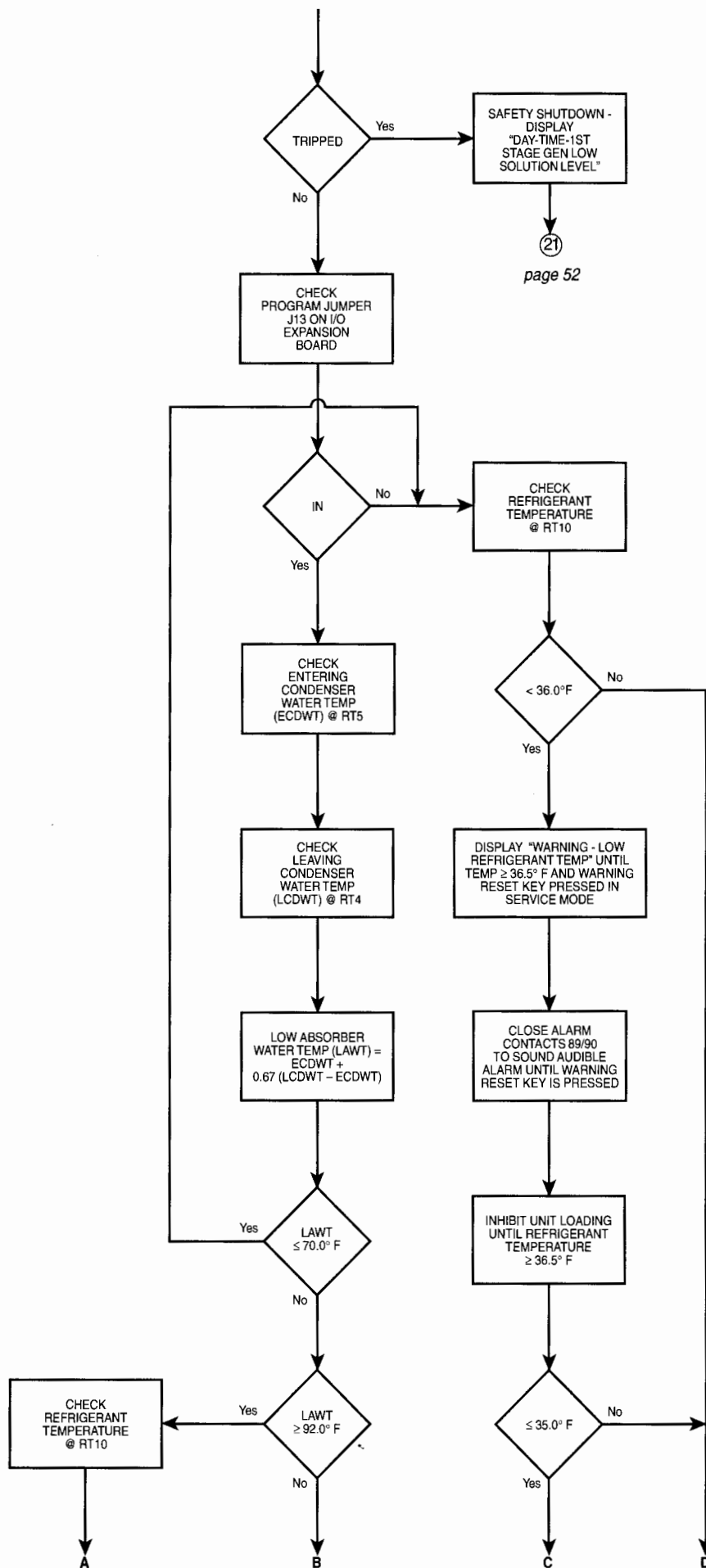

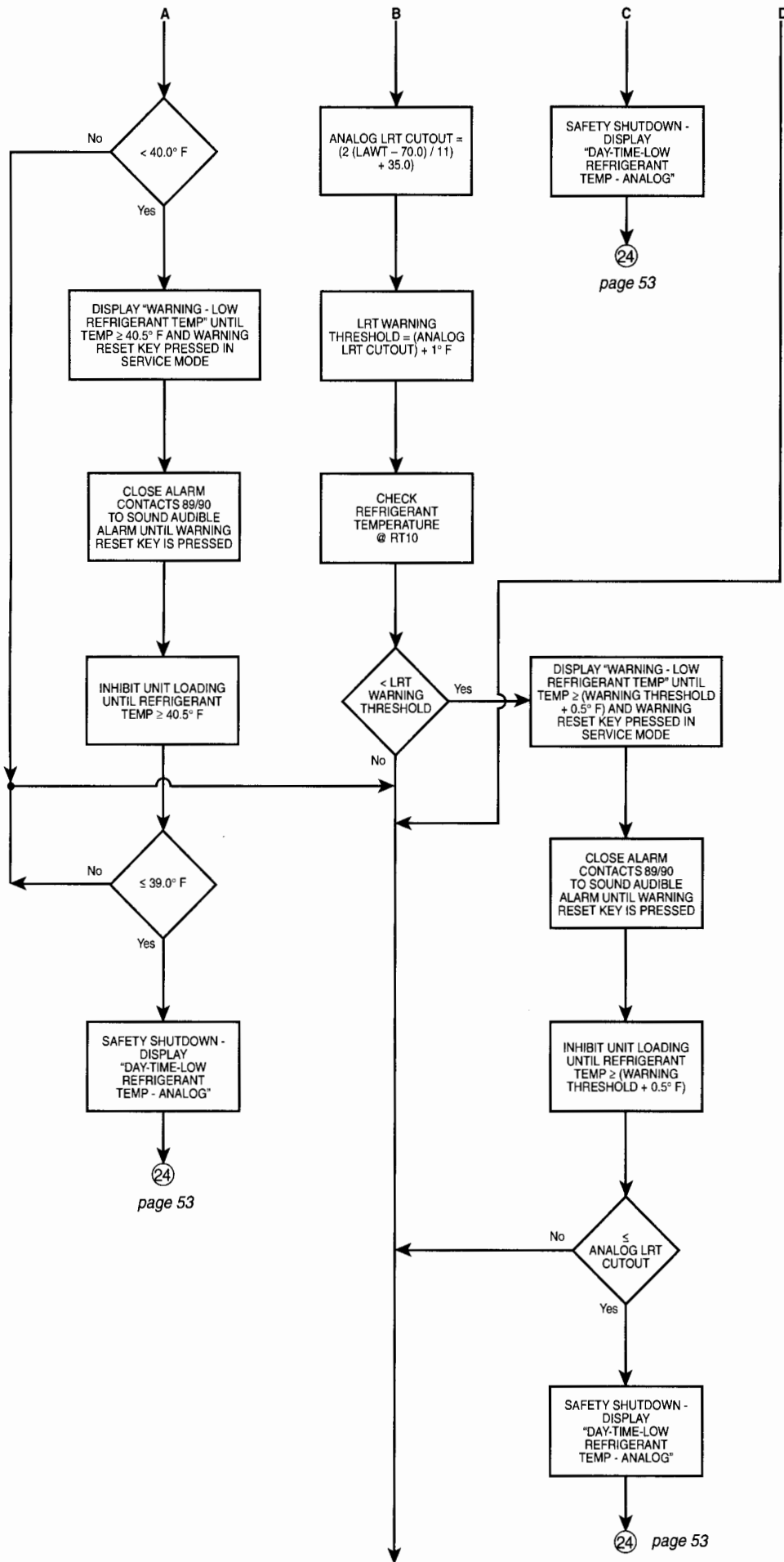

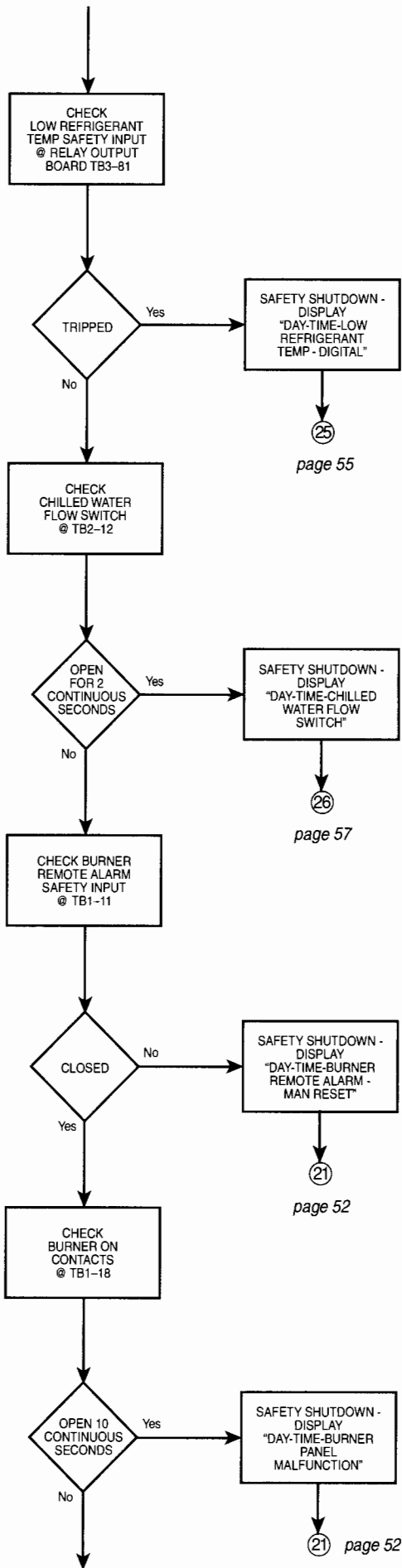

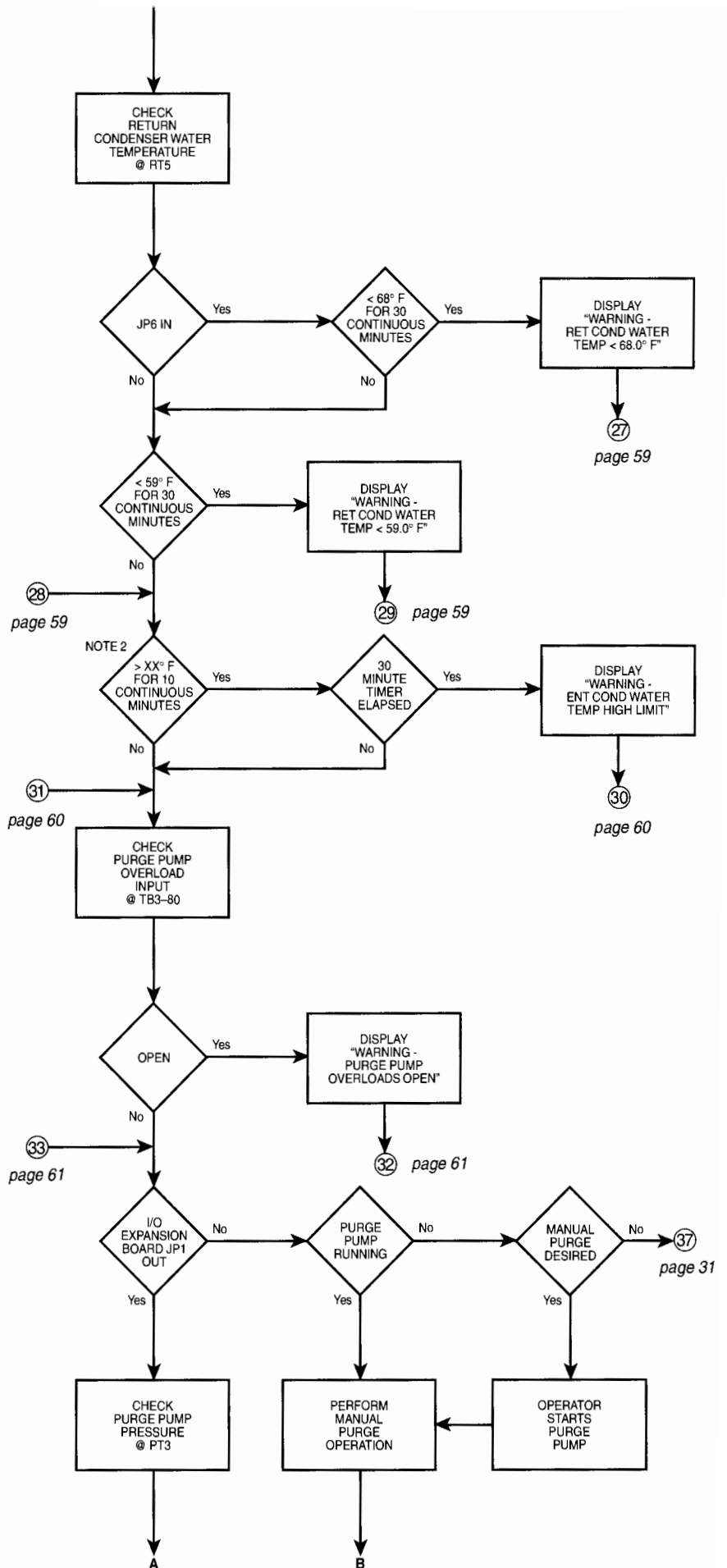

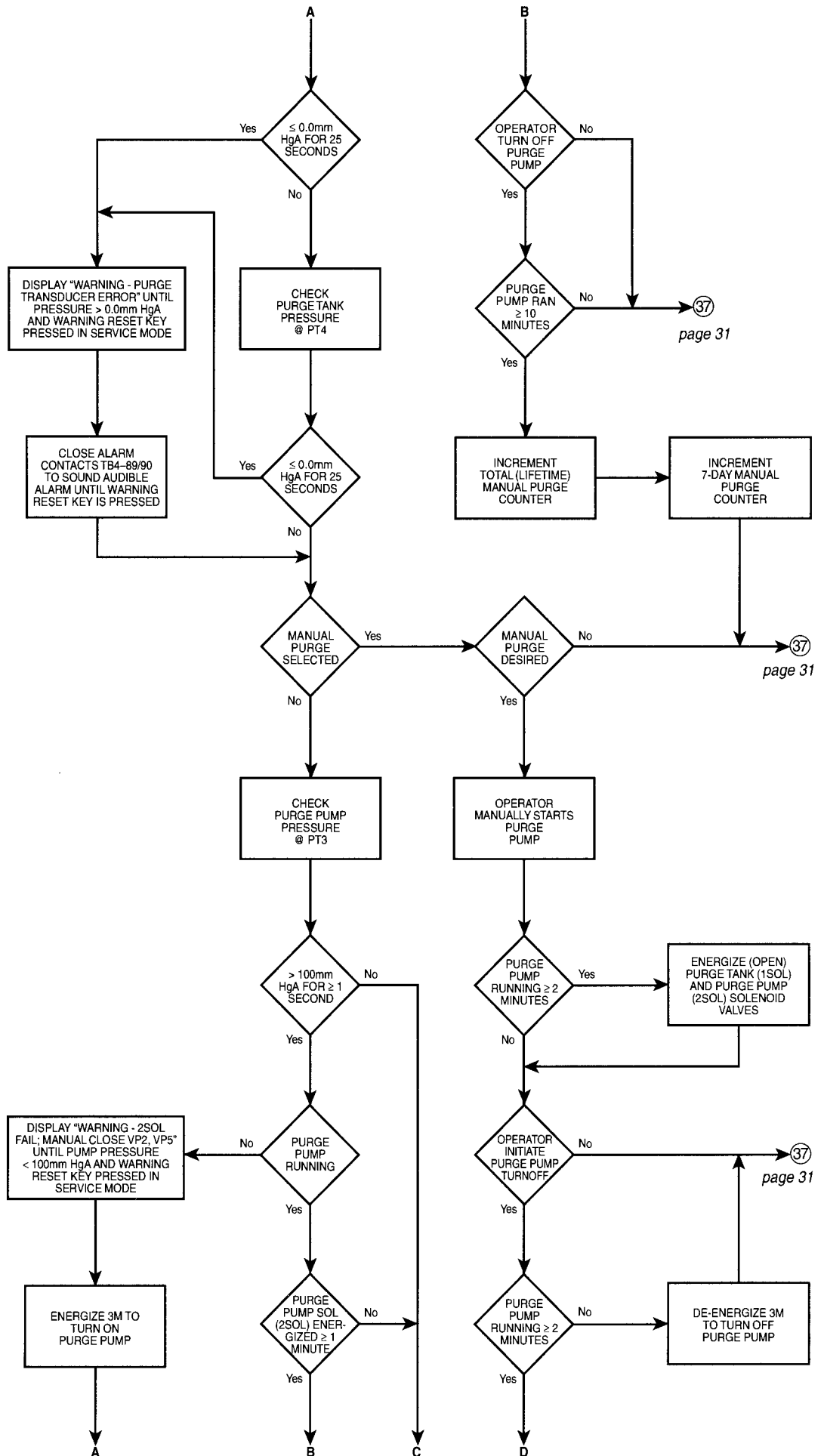

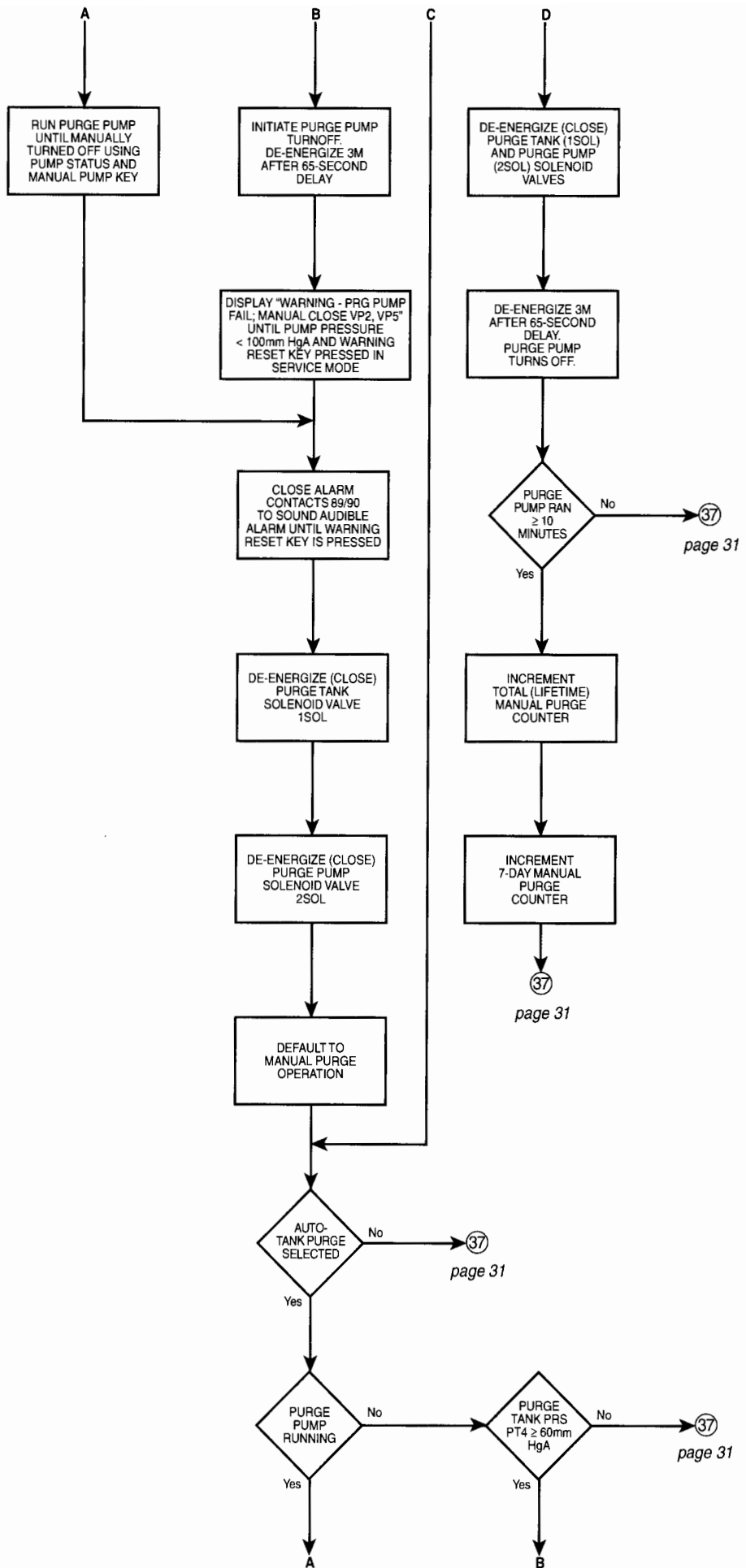

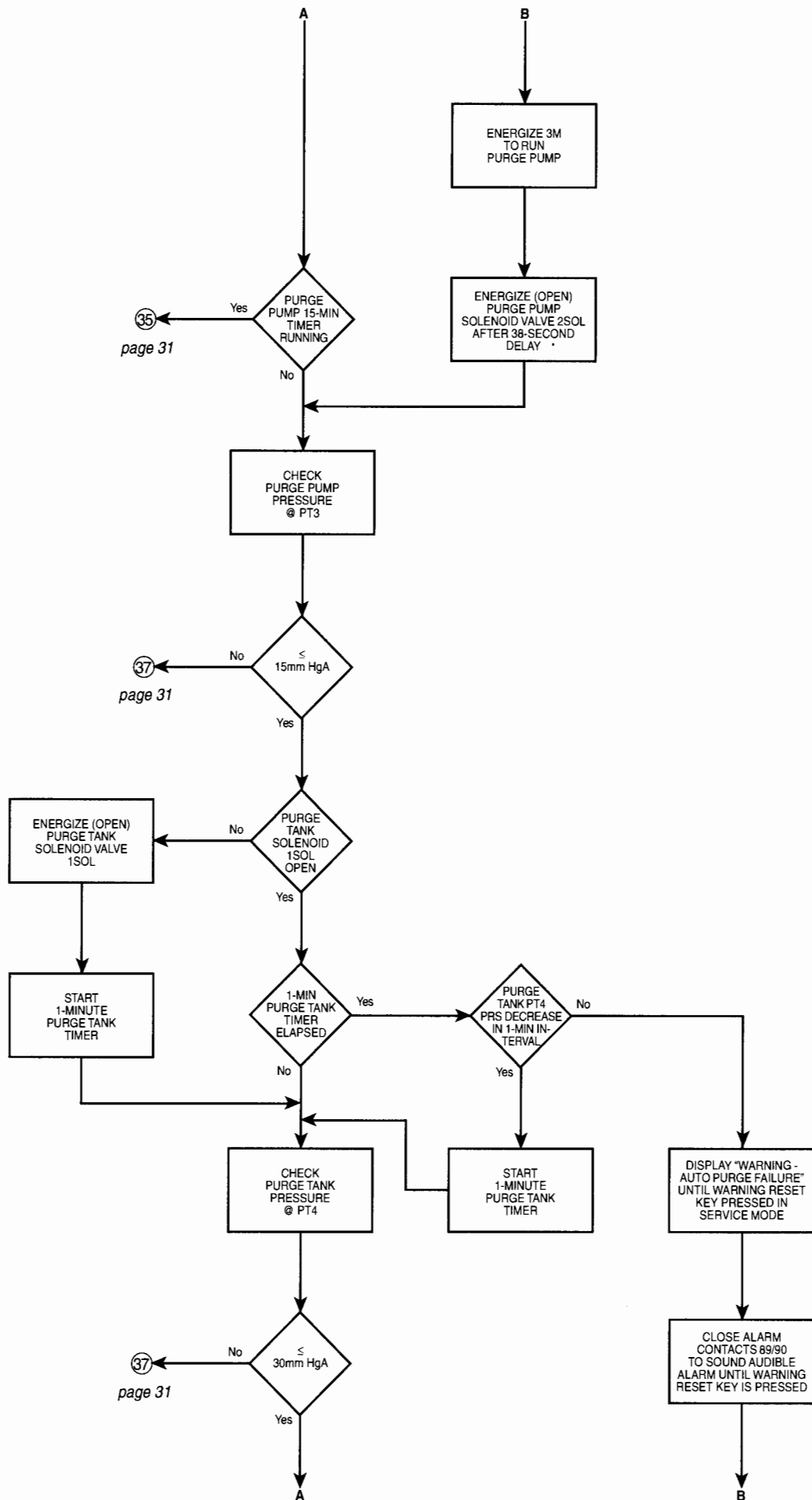

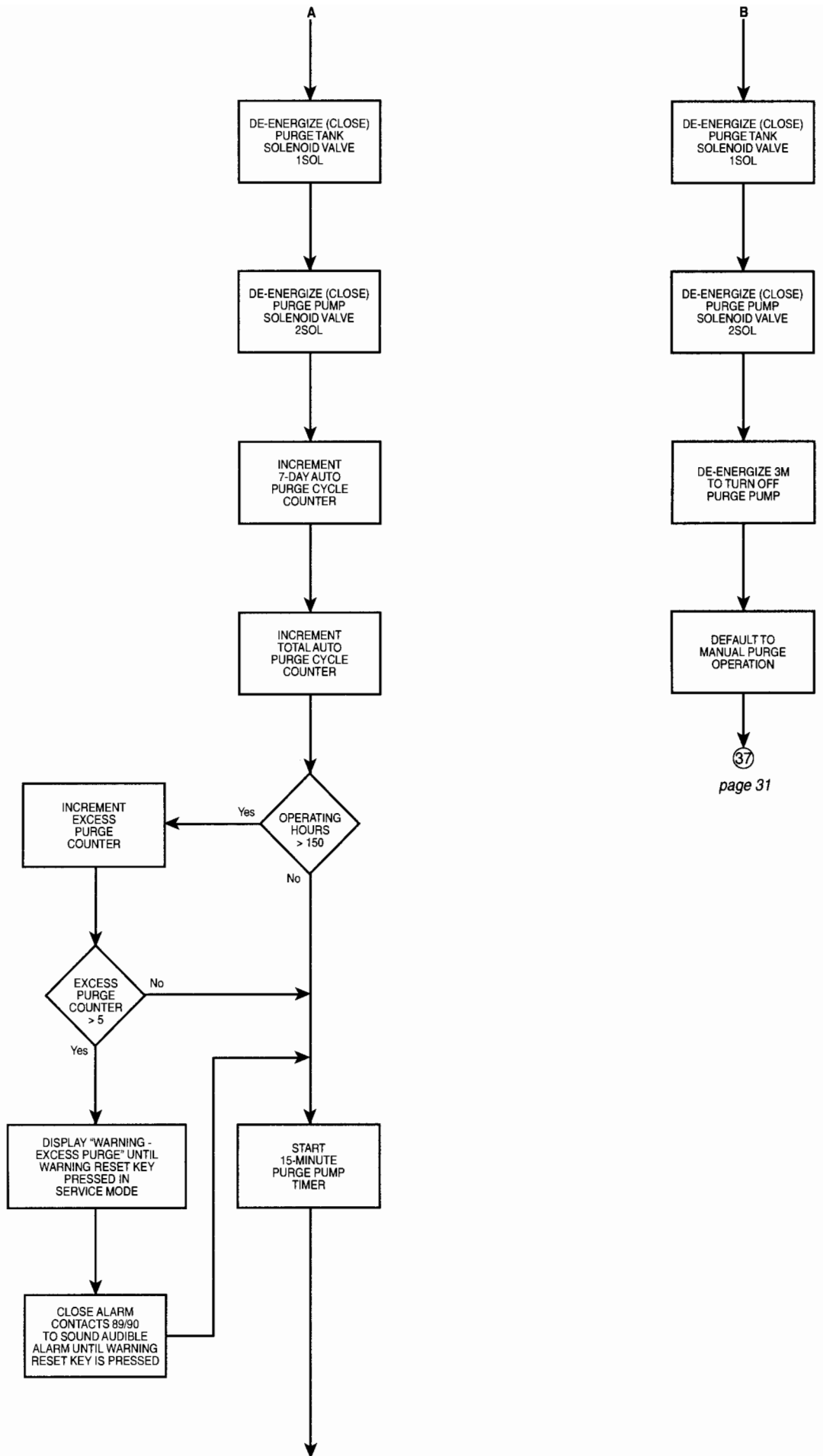

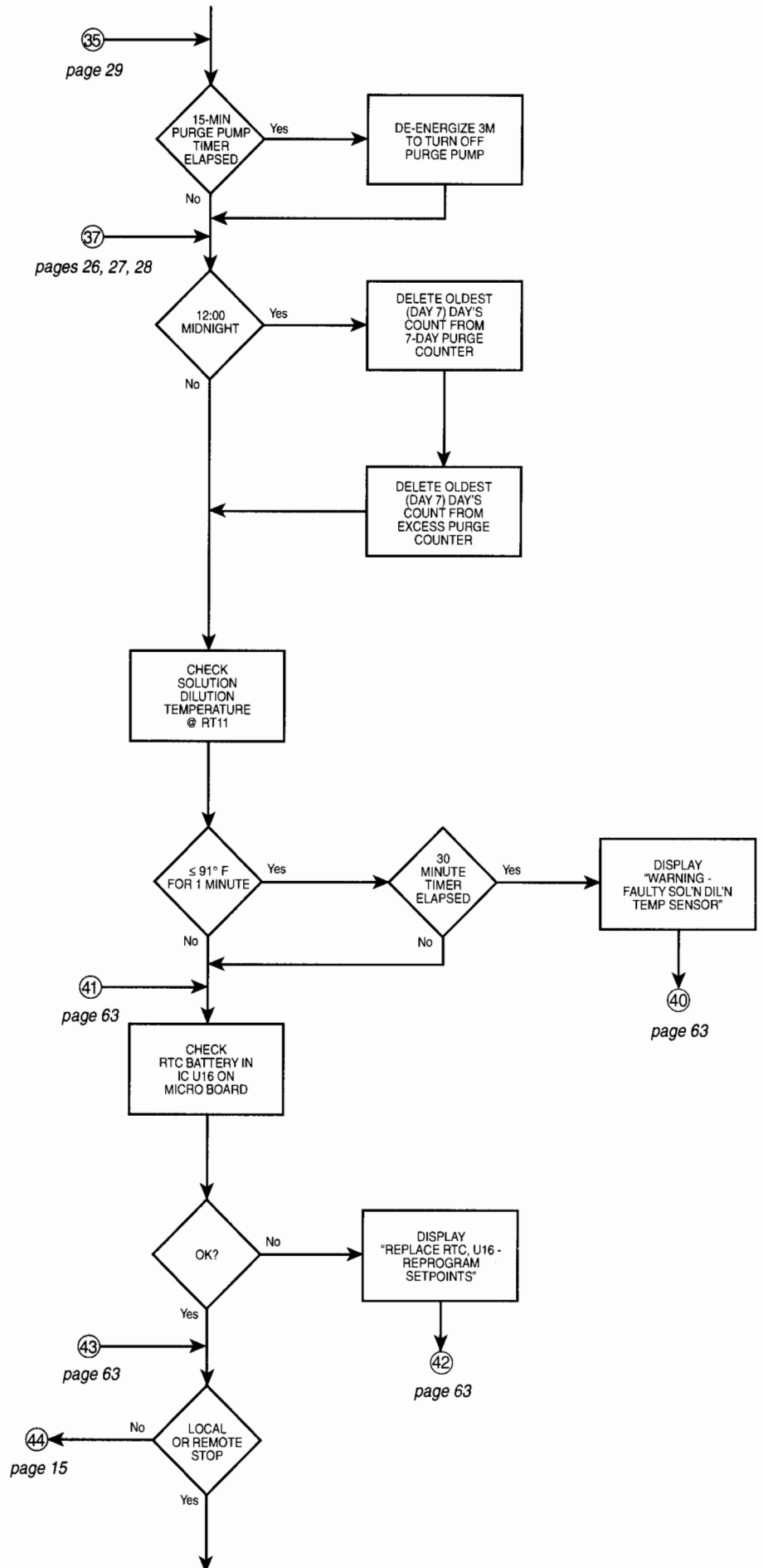

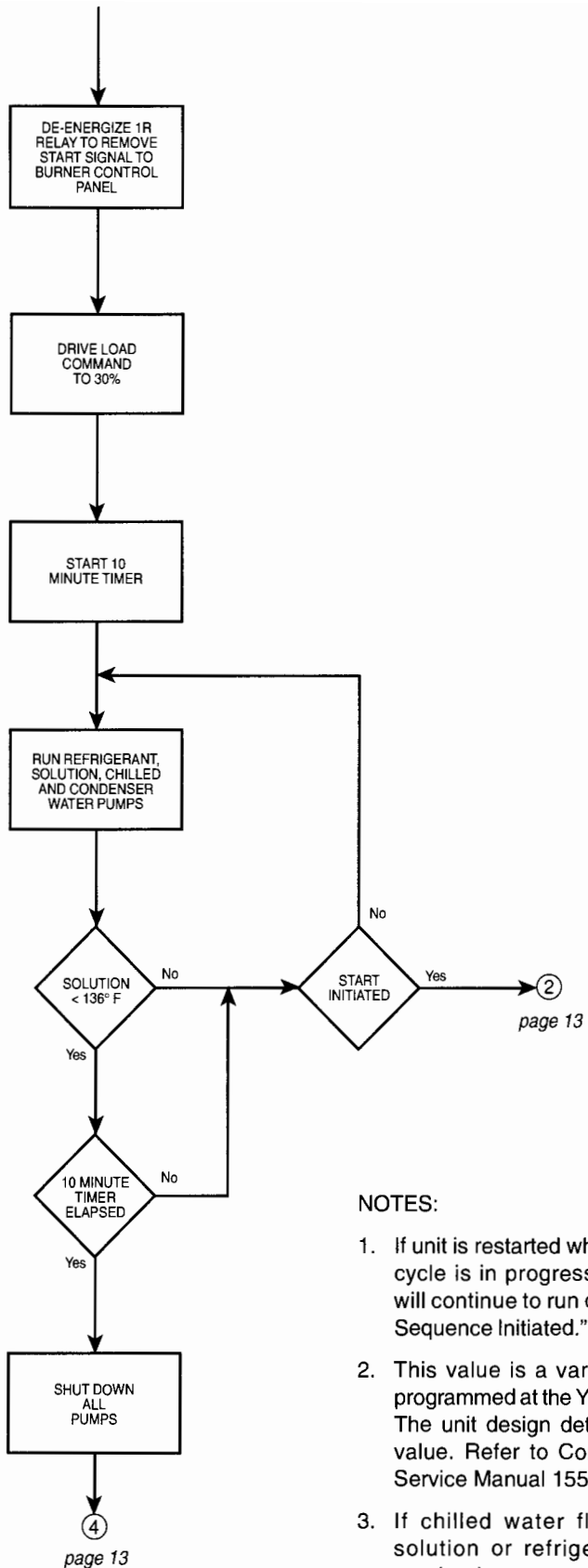

NOTES:

1. If unit is restarted while a dilution cycle is in progress, all pumps will continue to run during "Start Sequence Initiated."
2. This value is a variable that is programmed at the YORK factory. The unit design determines the value. Refer to Control Center Service Manual 155.17-M2.
3. If chilled water flow switch, solution or refrigerant pump overloads open or a low refrigerant temperature shutdown occurs while a dilution cycle is in progress, the dilution cycle will be terminated.

SAFETY SHUTDOWN CYCLING SHUTDOWN AND ALARM

UNIT OPERATION SUBROUTINES

GAS/OIL-FIRED COOLING MODE (Equipped with Automatic Purge System)

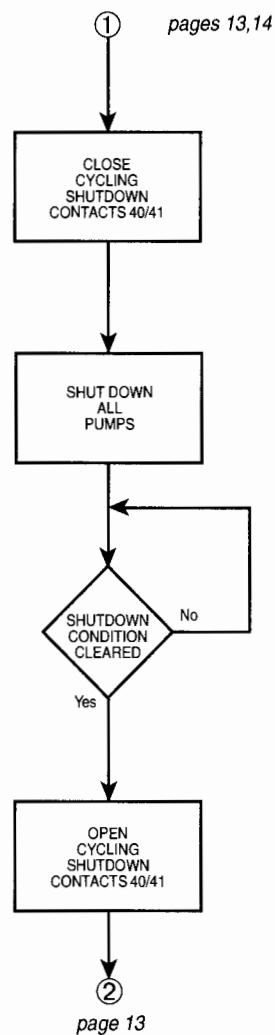

CLOSE
CYCLING
SHUTDOWN
CONTACTS 42/43

SHUT DOWN
ALL
PUMPS

SHUTDOWN
CONDITION
CLEARED

No

Yes

OPERATOR
MOVE UNIT SW
TO STOP/
RESET

No

Yes

OPEN
SAFETY
SHUTDOWN
CONTACTS 42/43

⑤ page 16

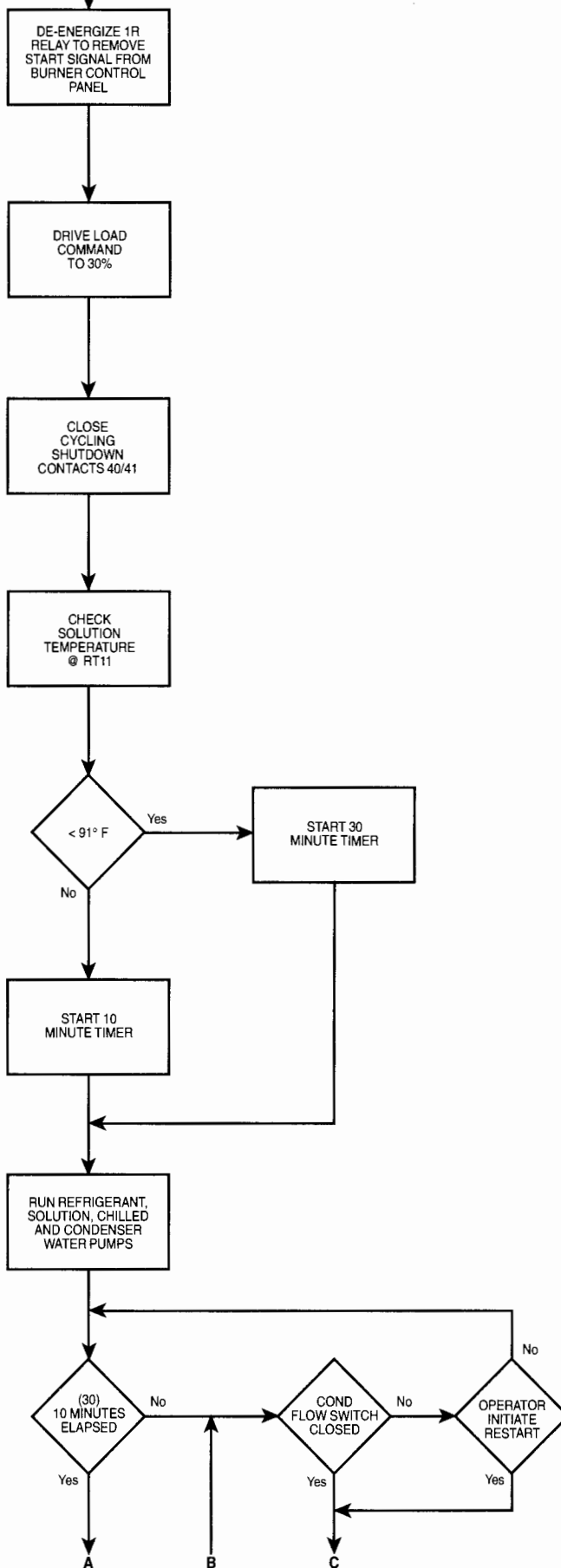

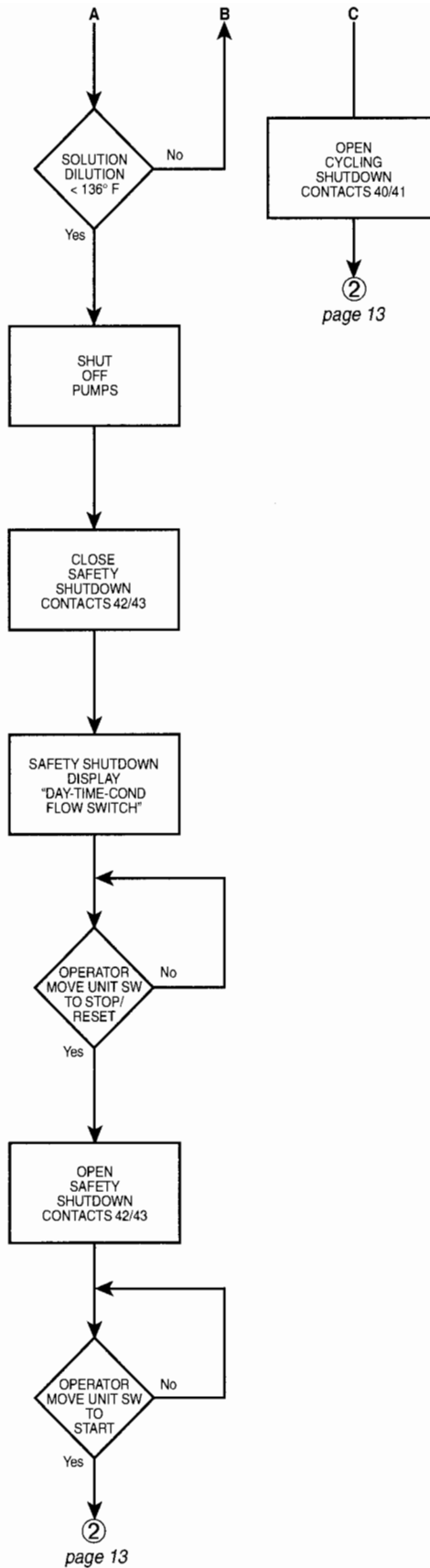

②
page 13

②
page 13

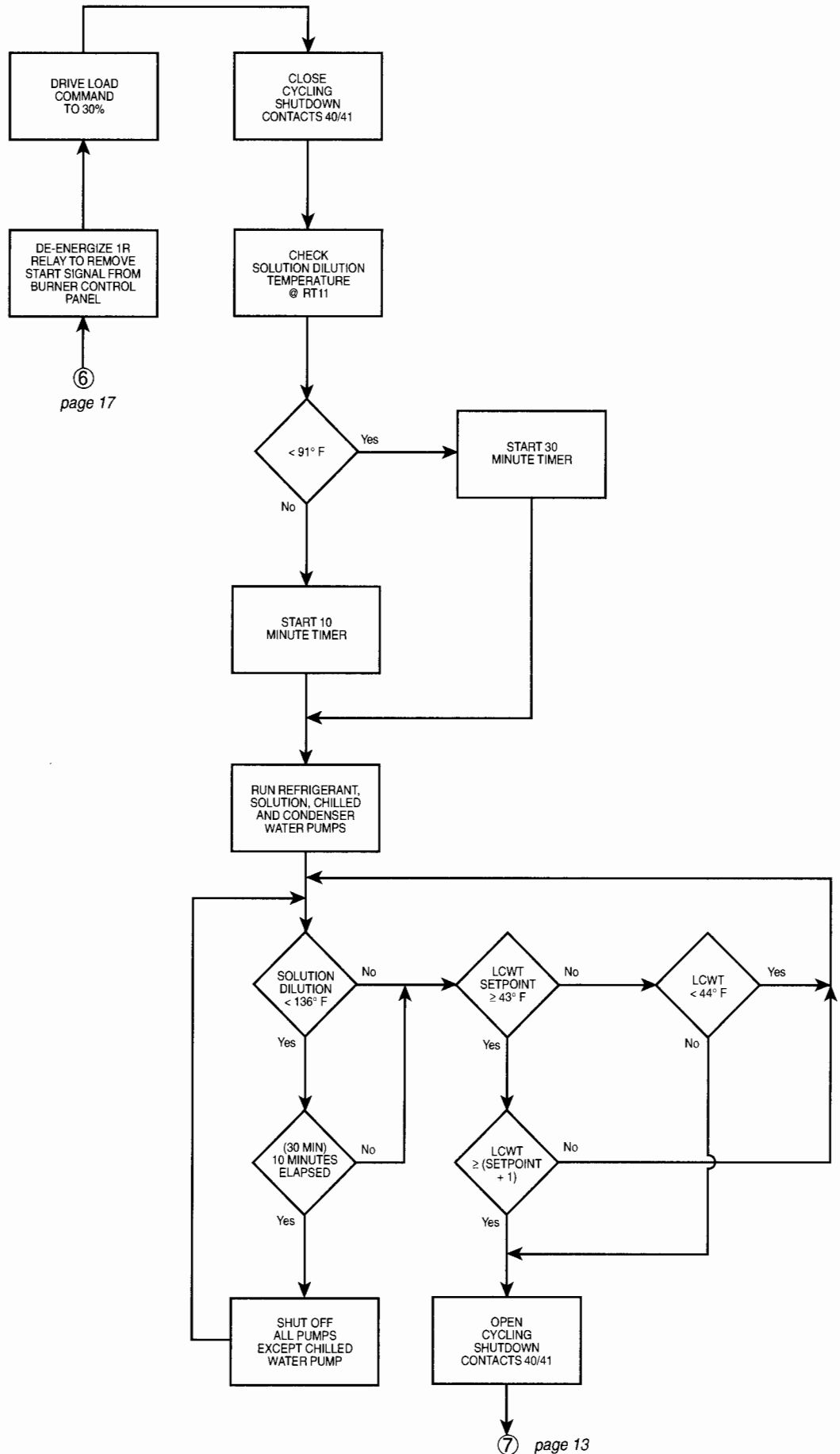

⑥
page 17

⑦ page 13

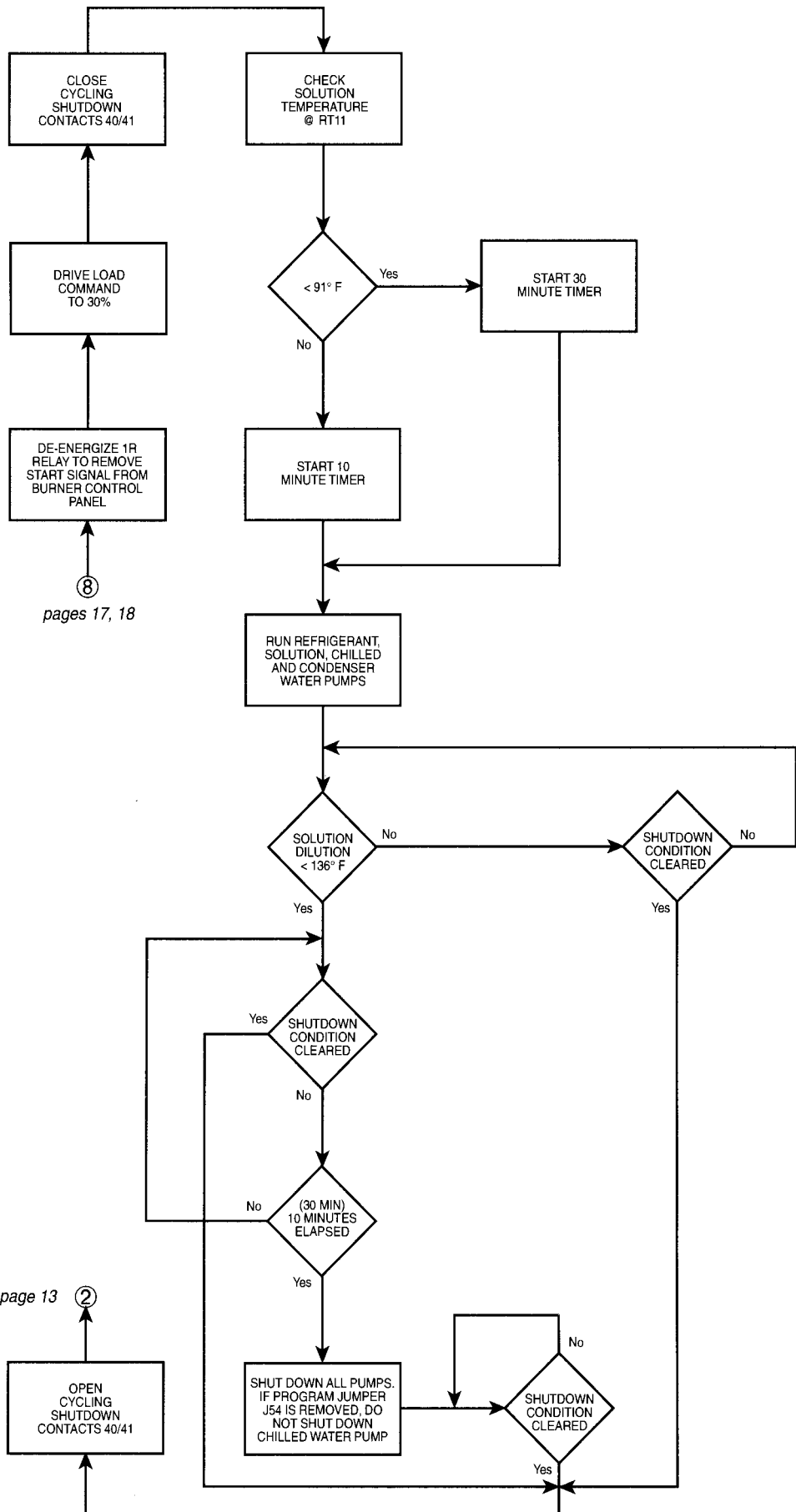

⑧
pages 17, 18

page 13 ②

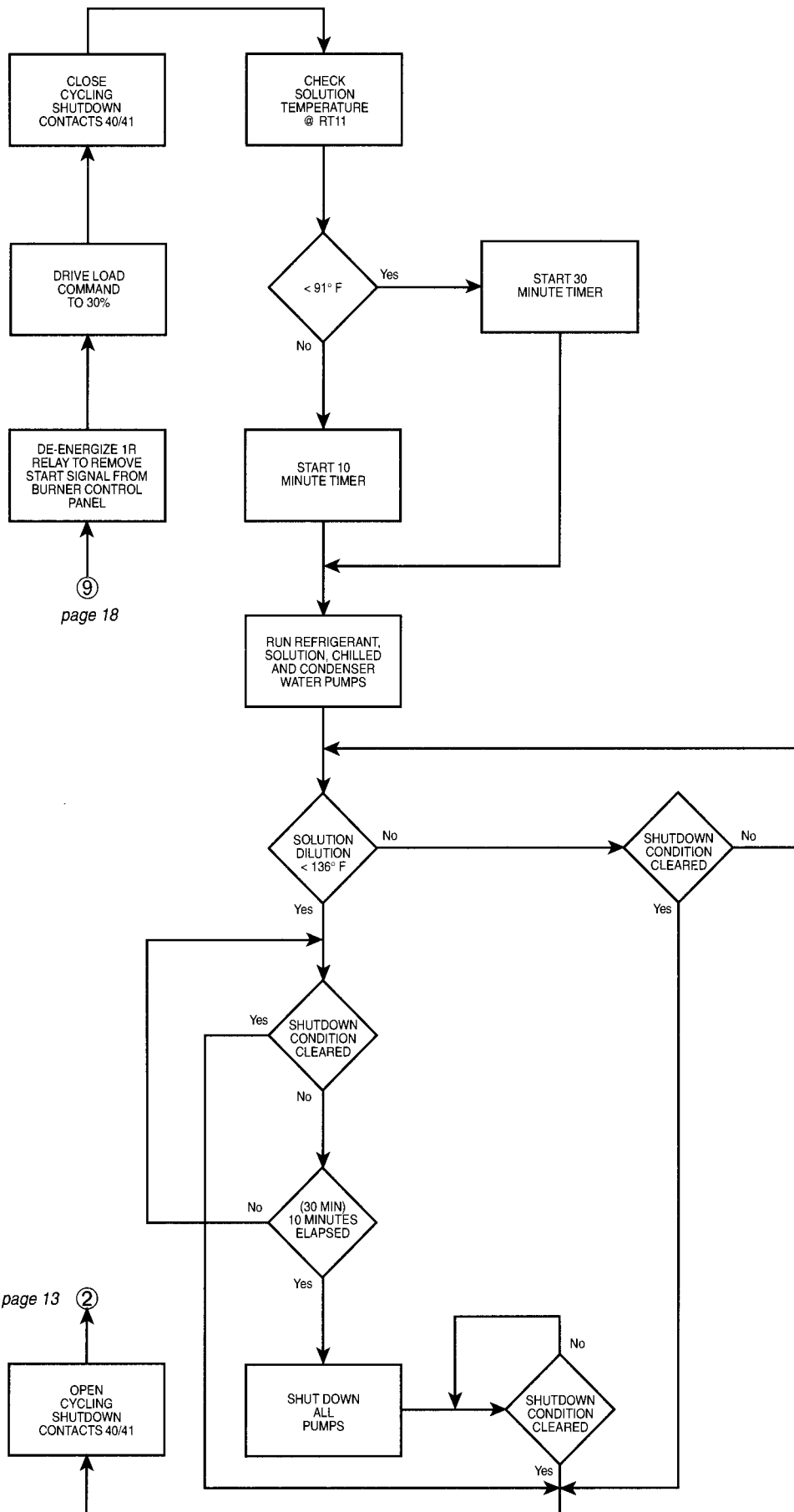

⑨
page 18

page 13 ②

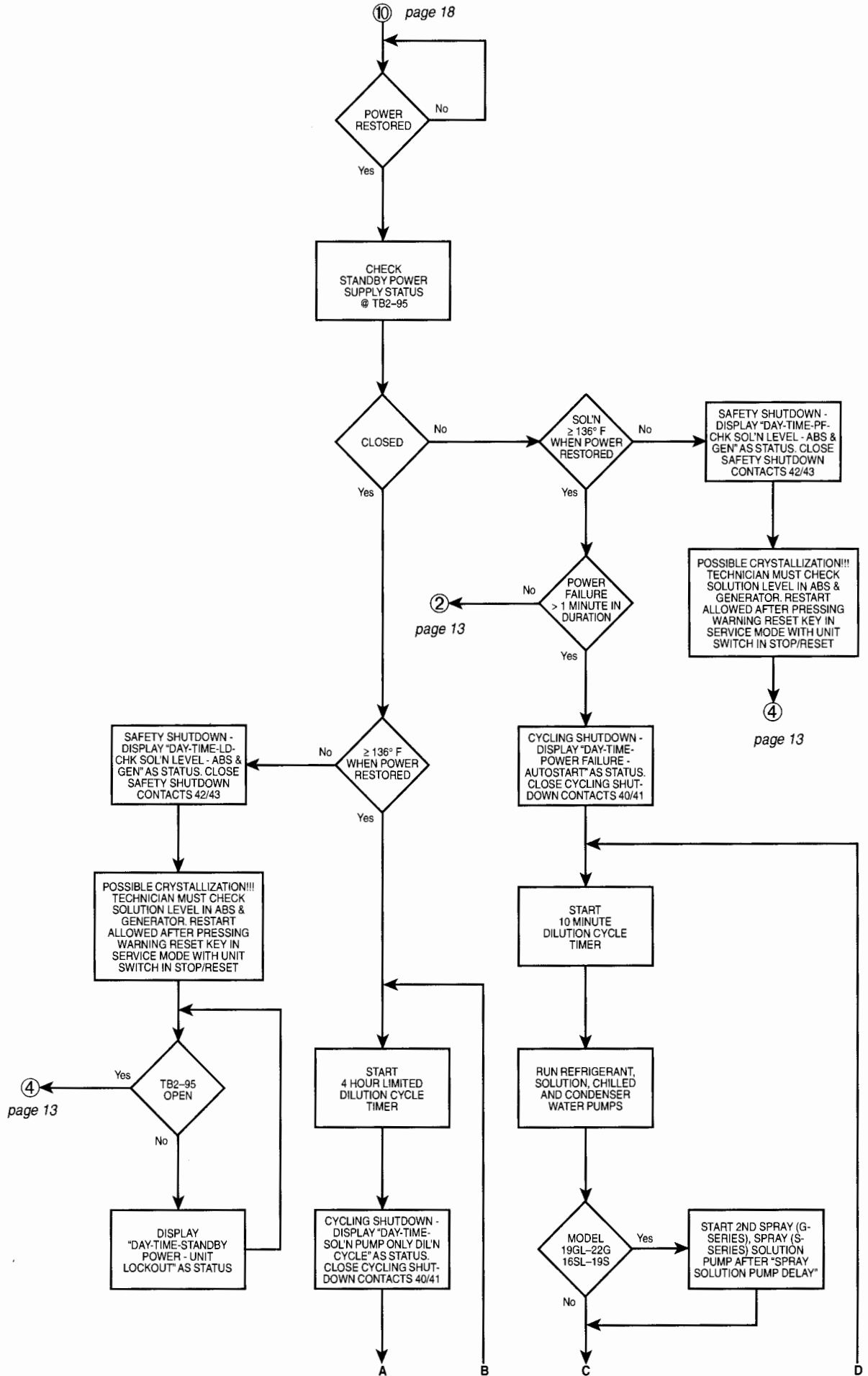

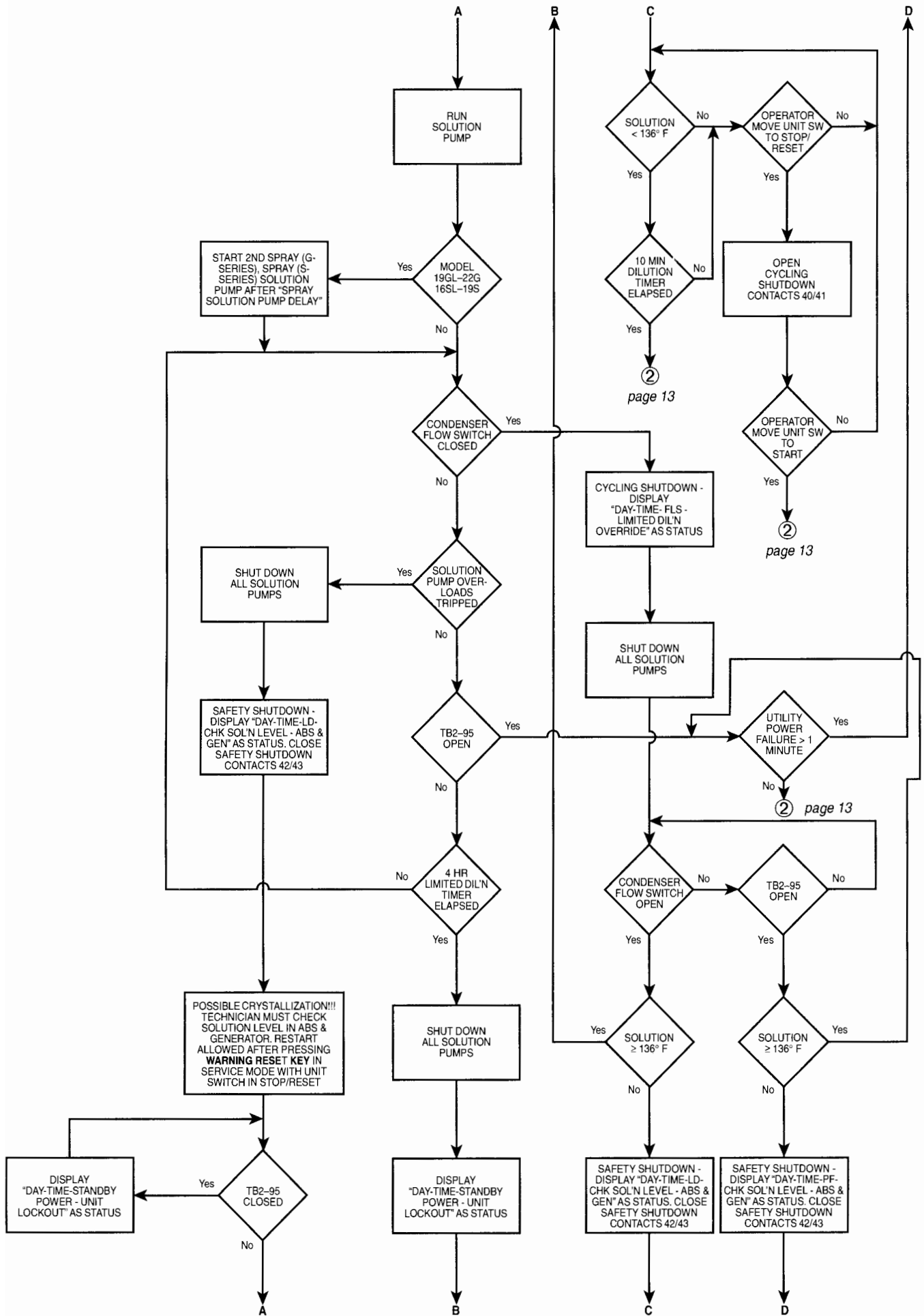

11 page 18

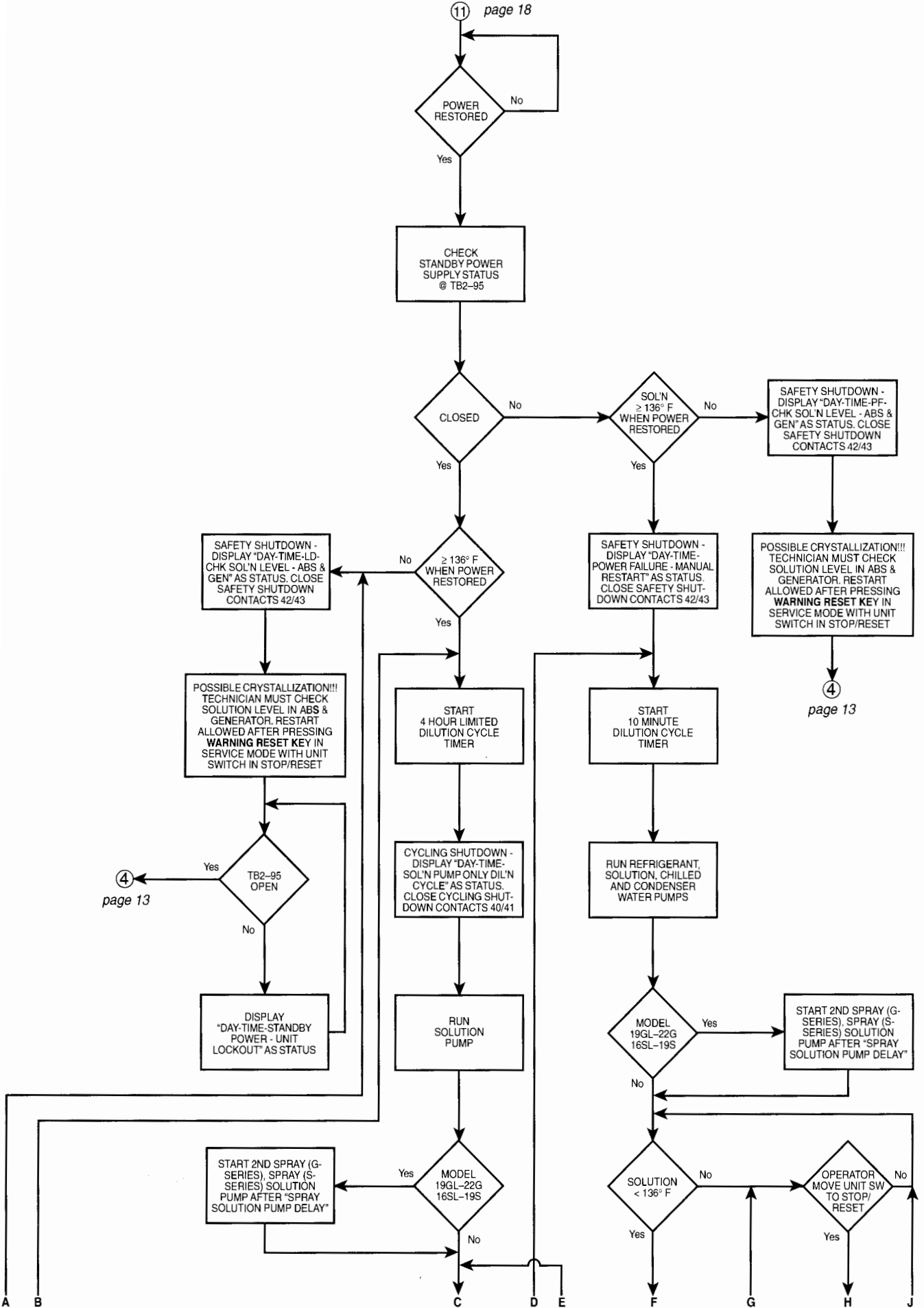

11 page 18

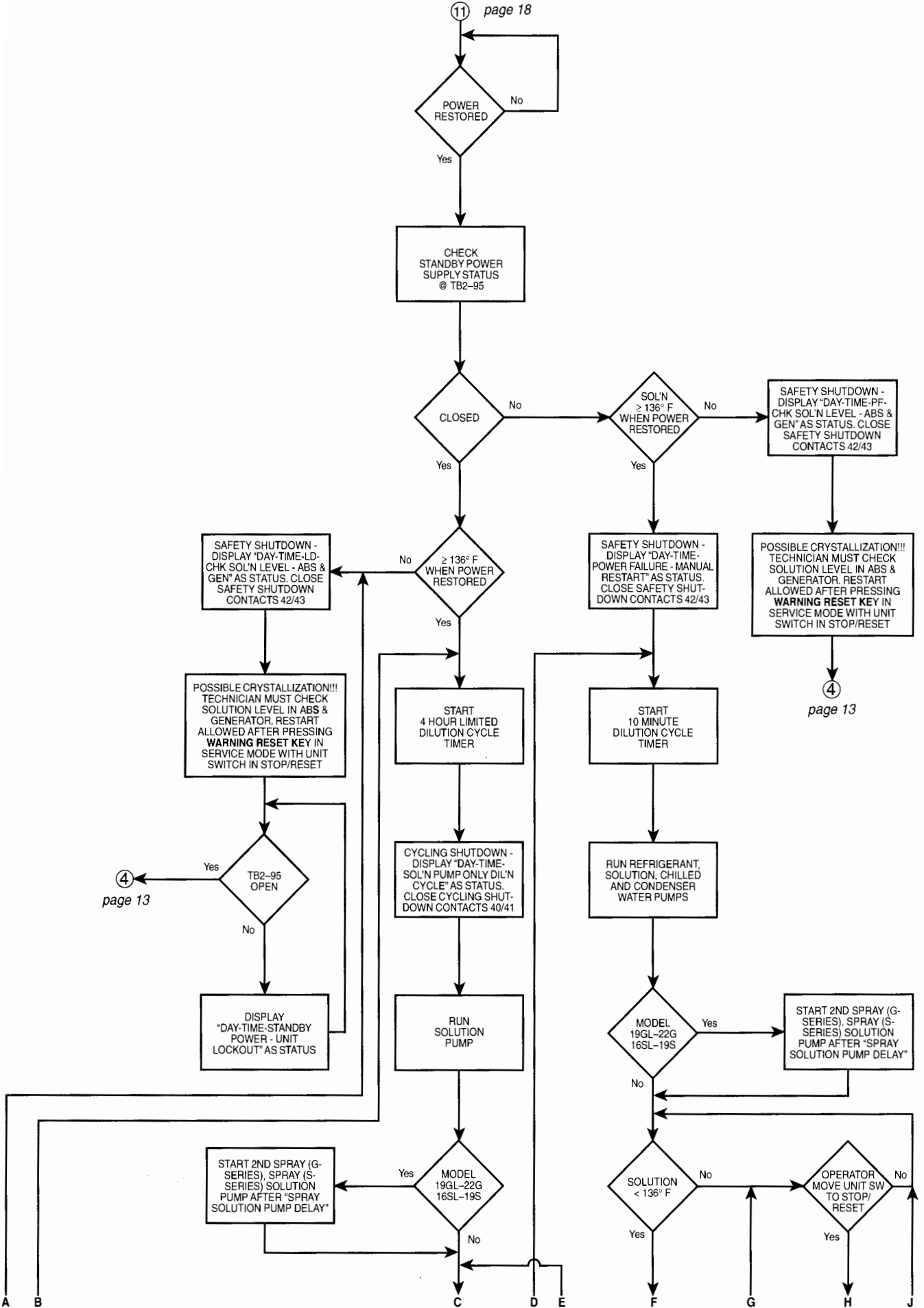

4 page 13

4 page 13

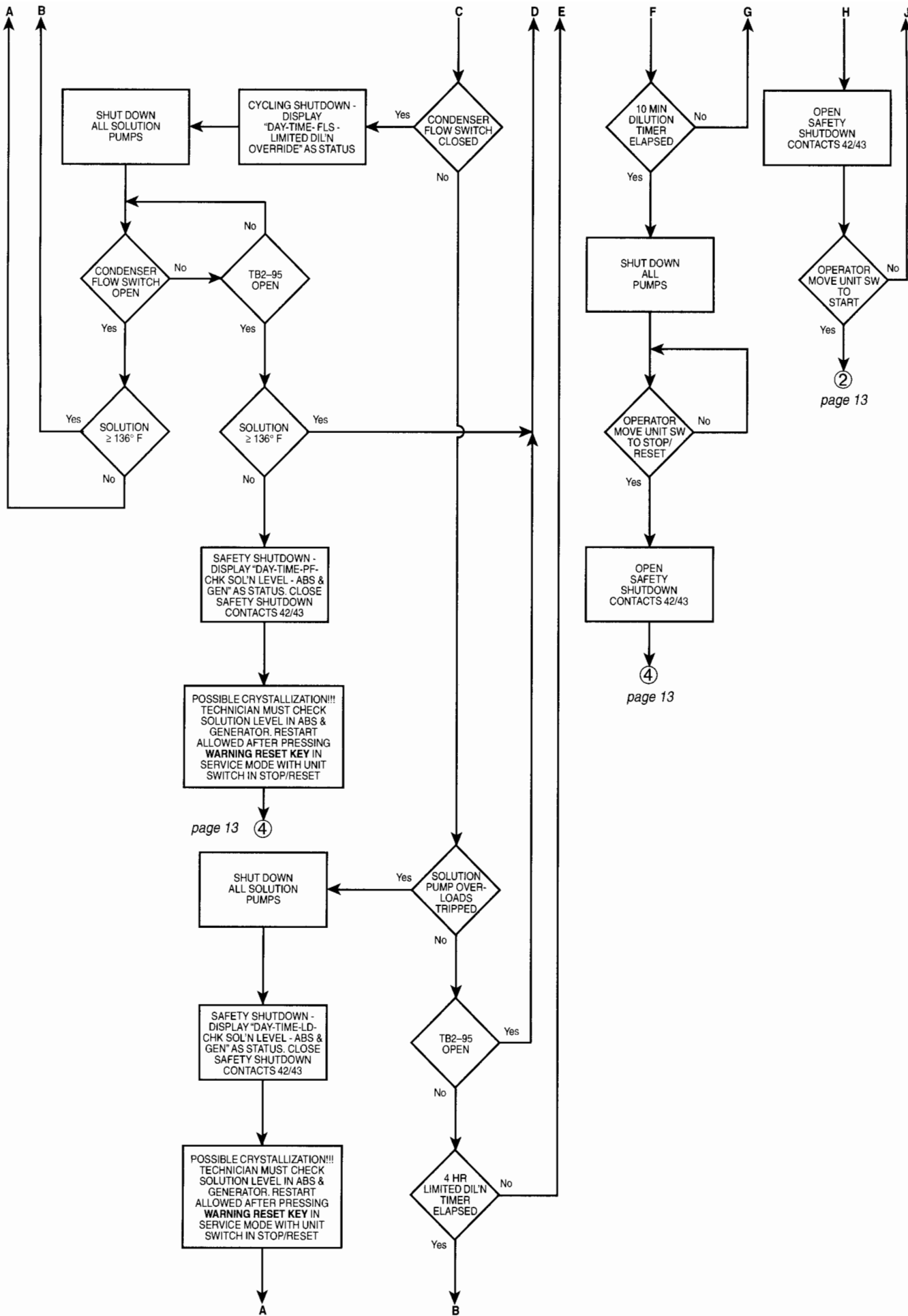

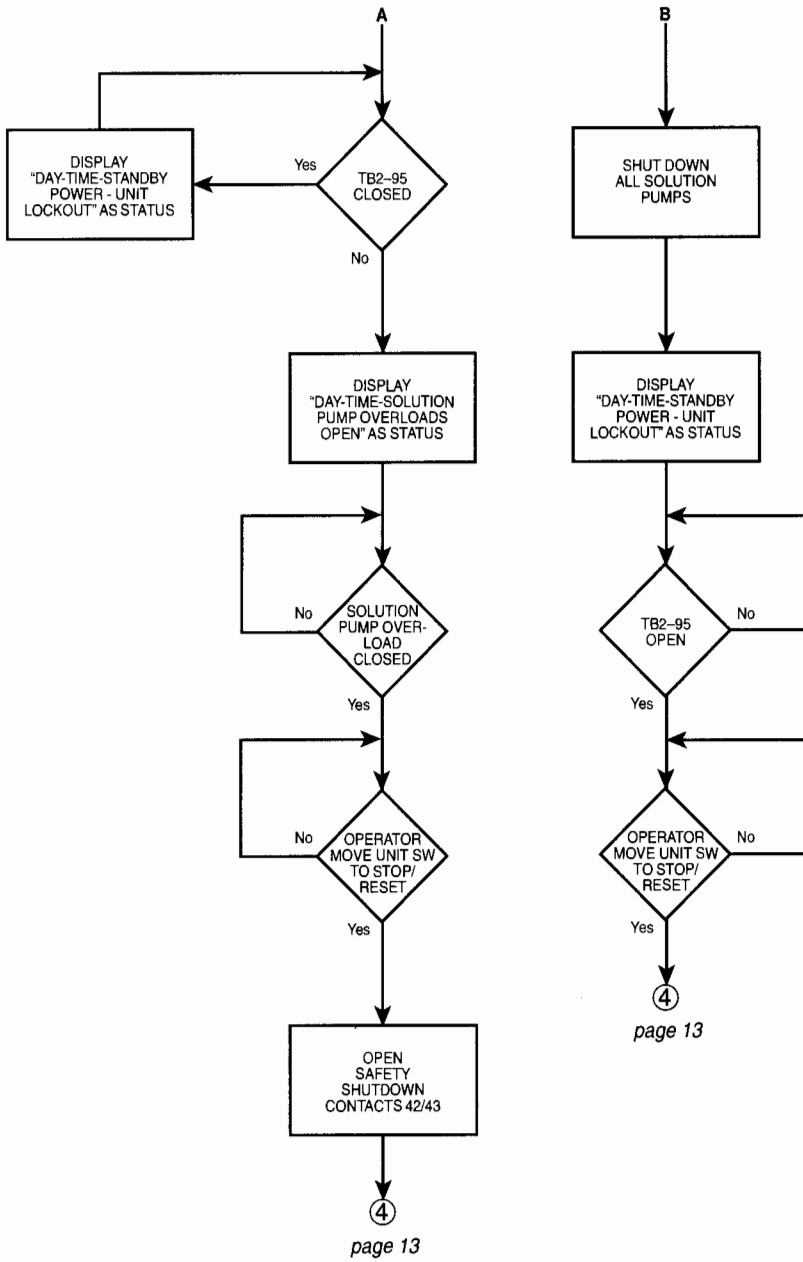

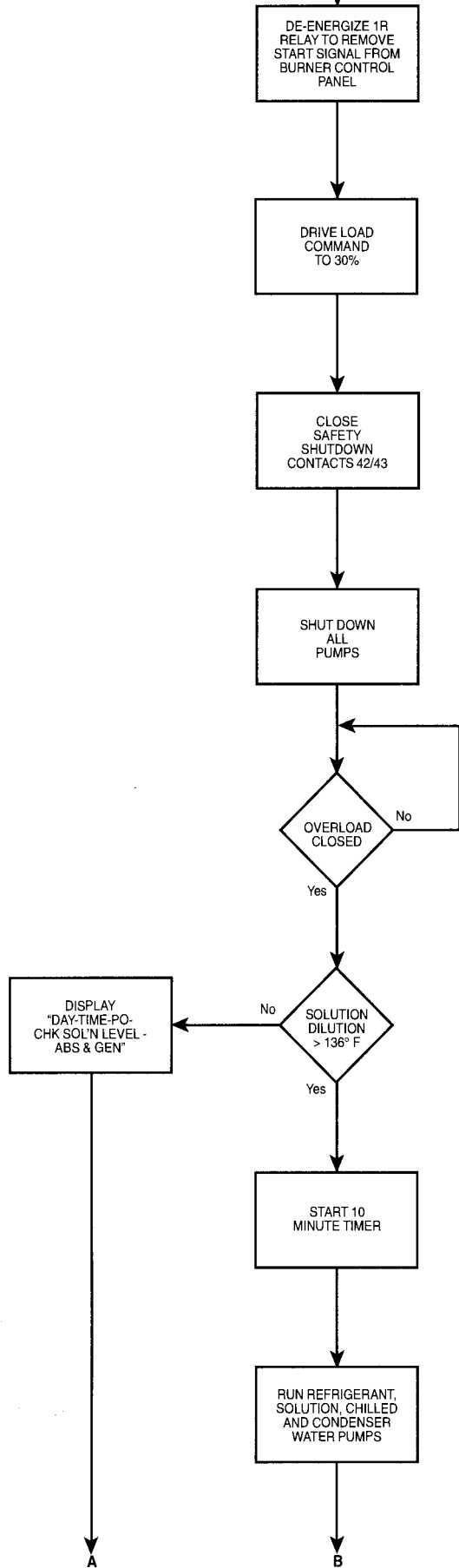

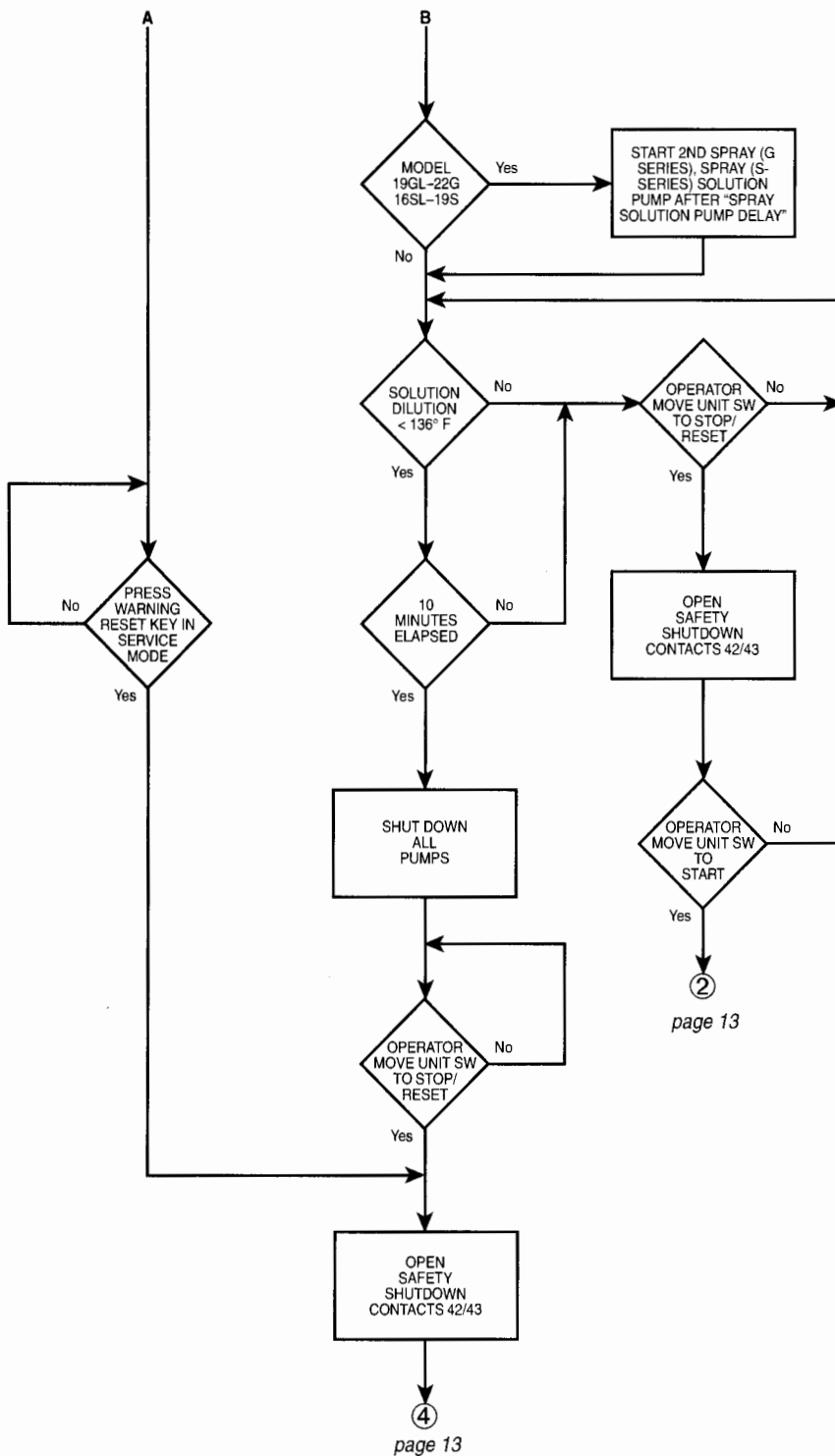

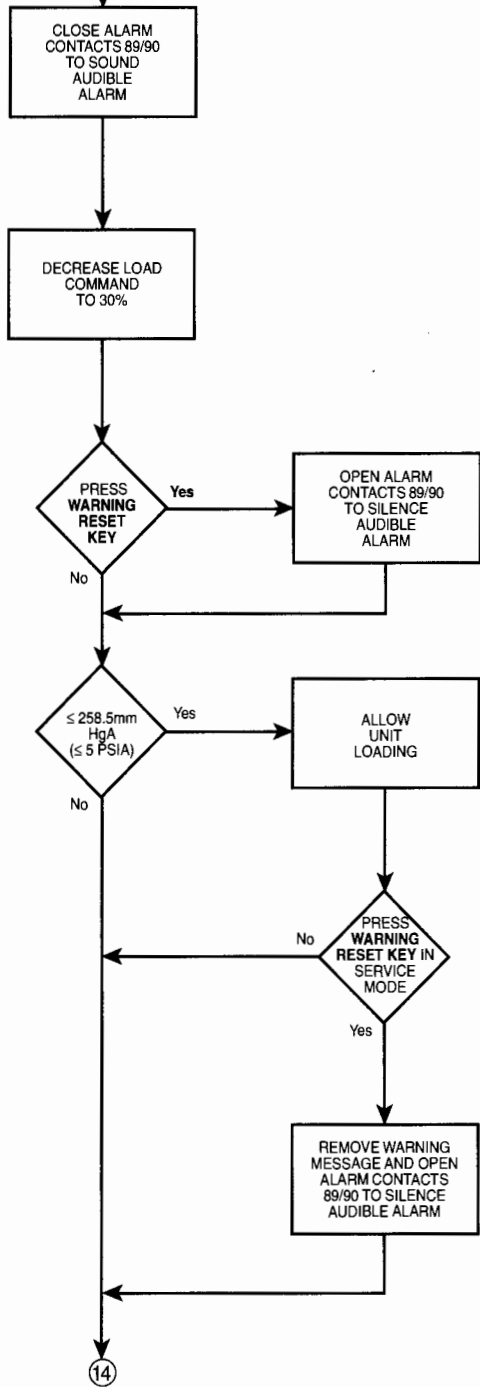

15 page 19

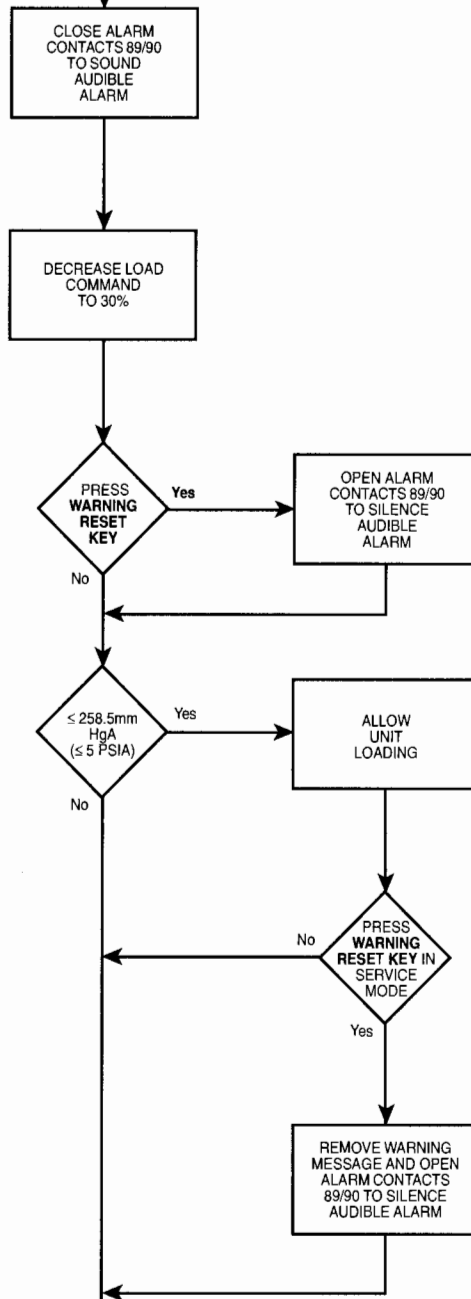

16 page 19

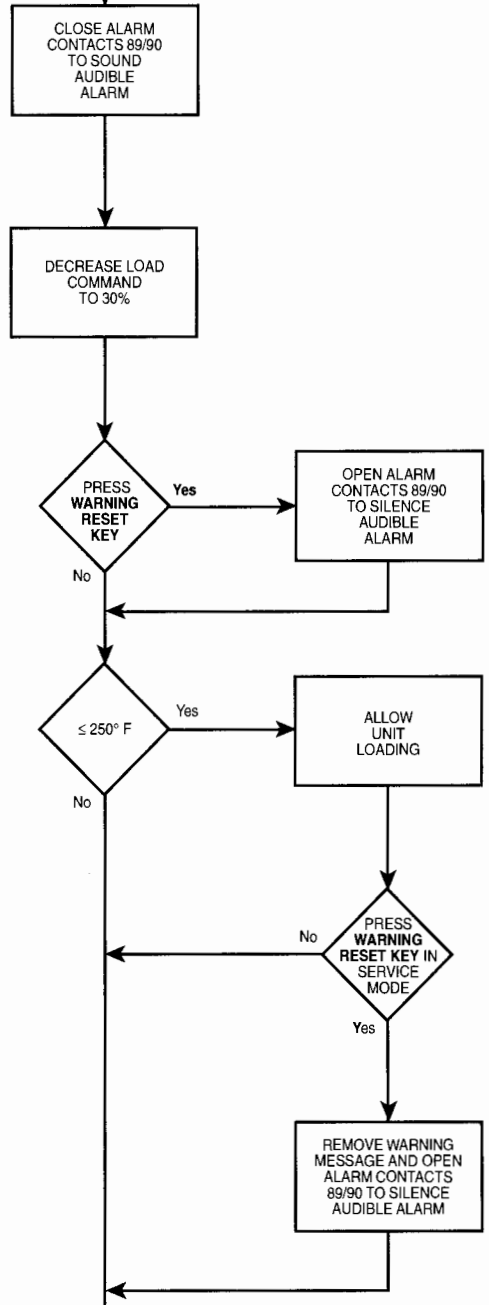

19 page 21

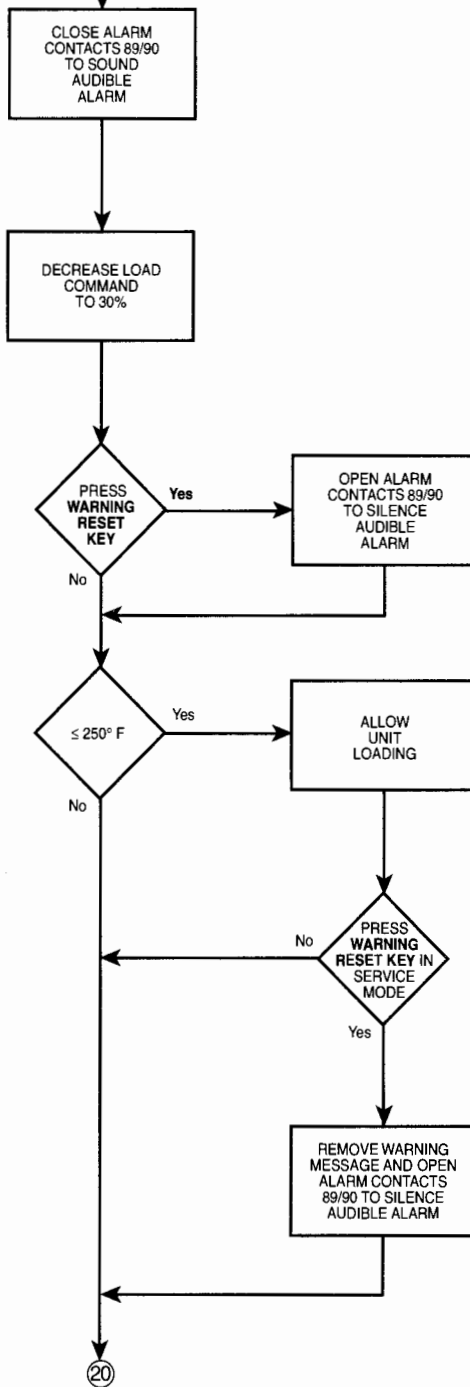

page 21

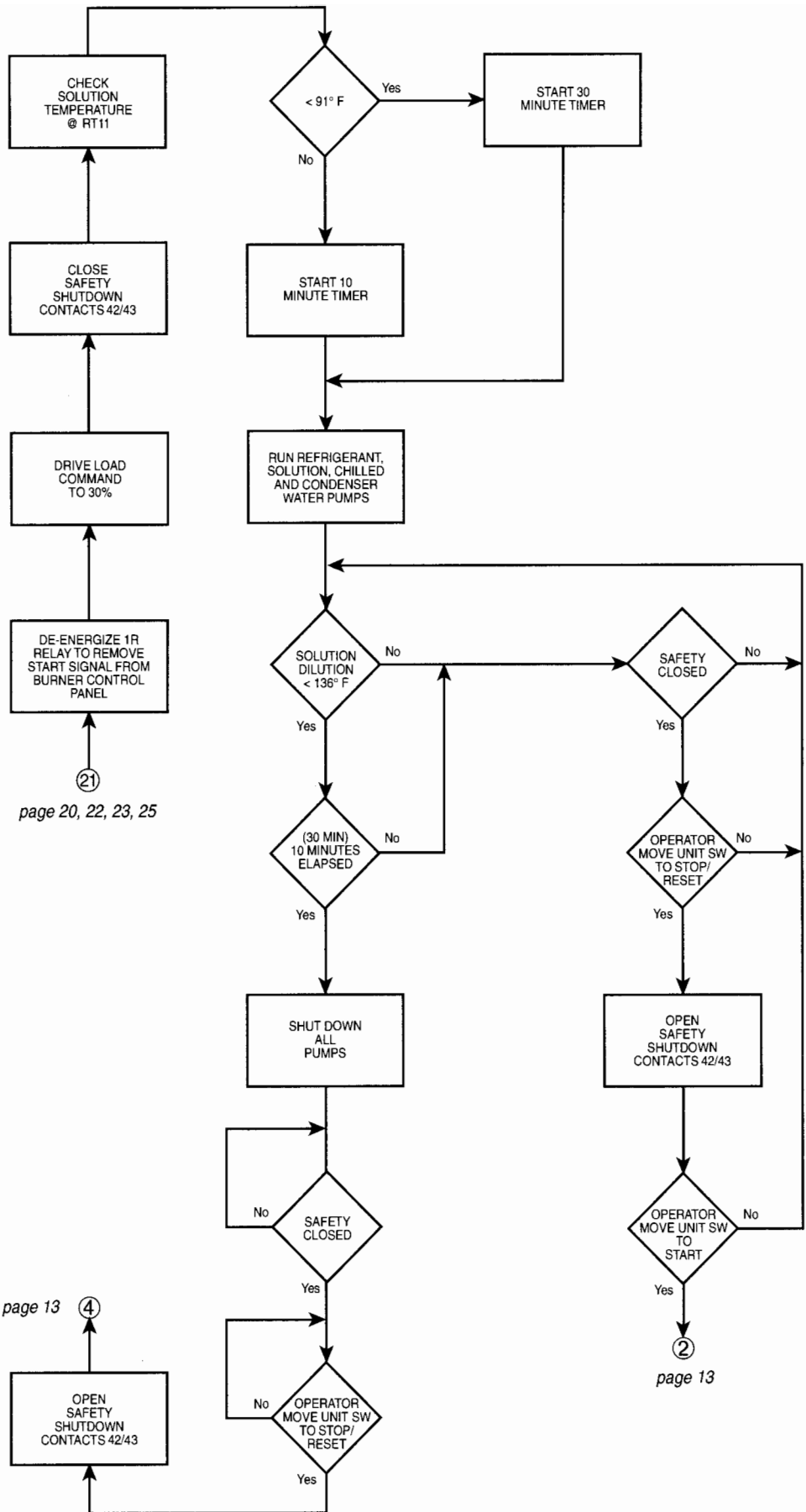

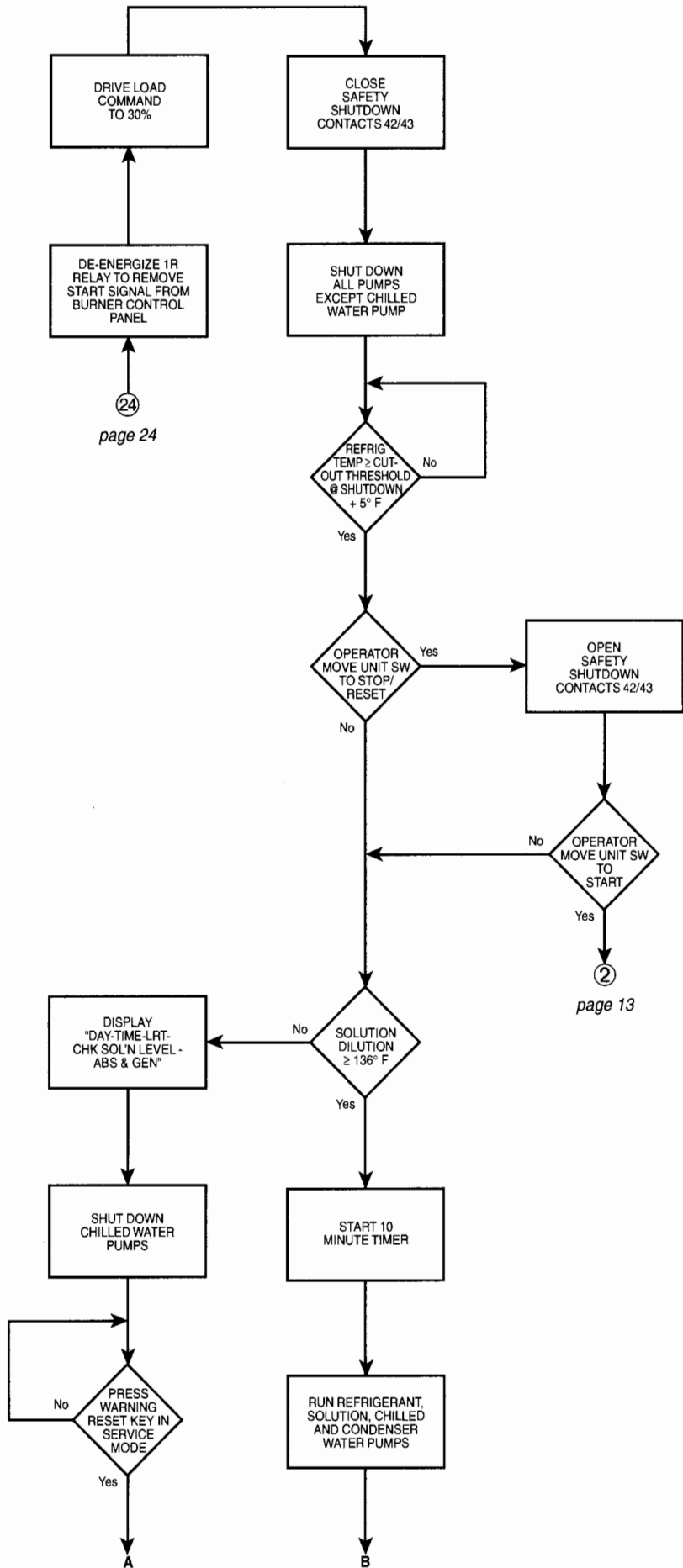

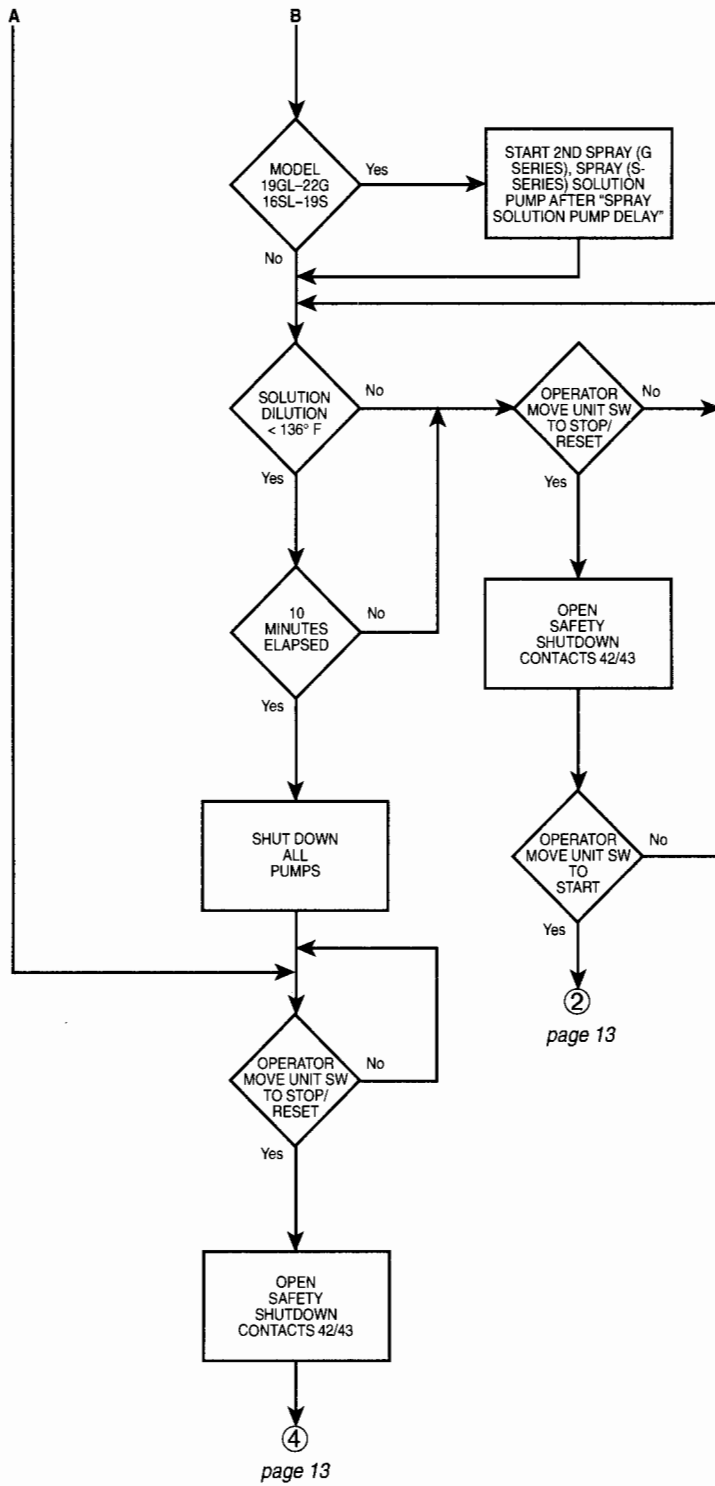

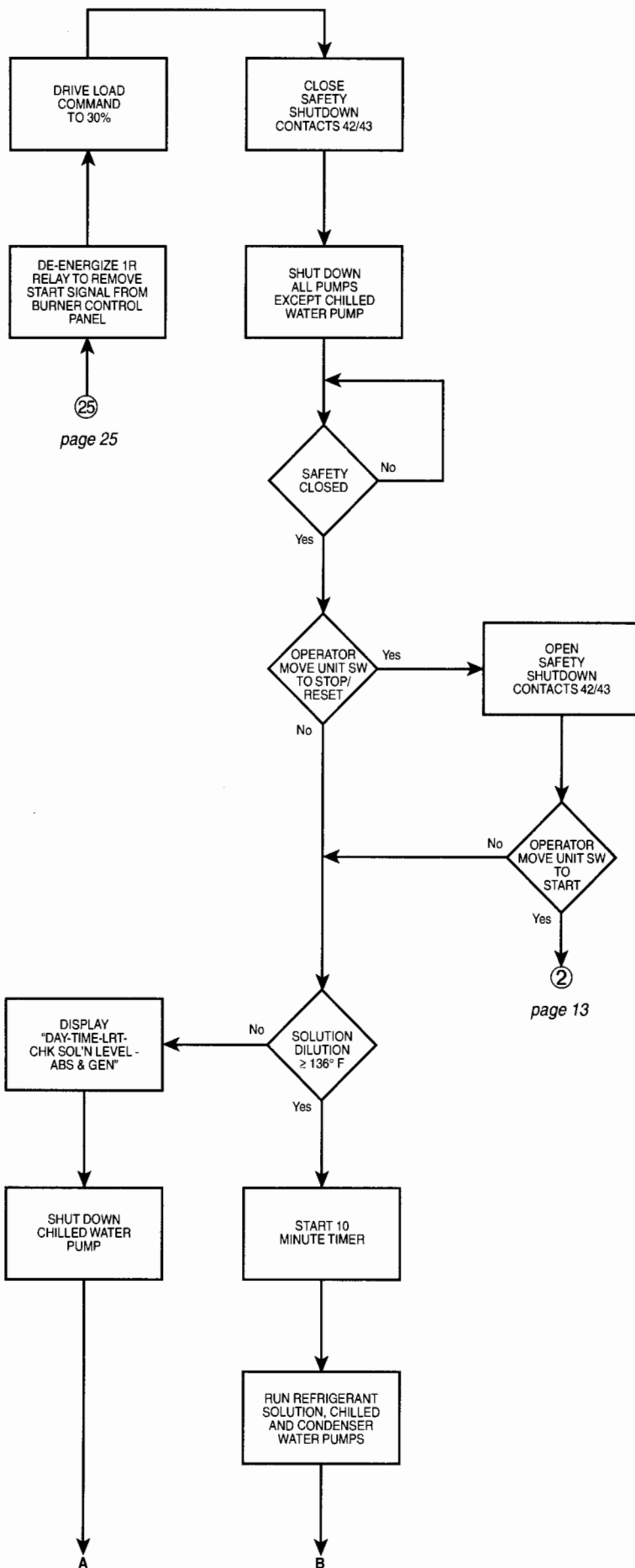

page 25

page 13

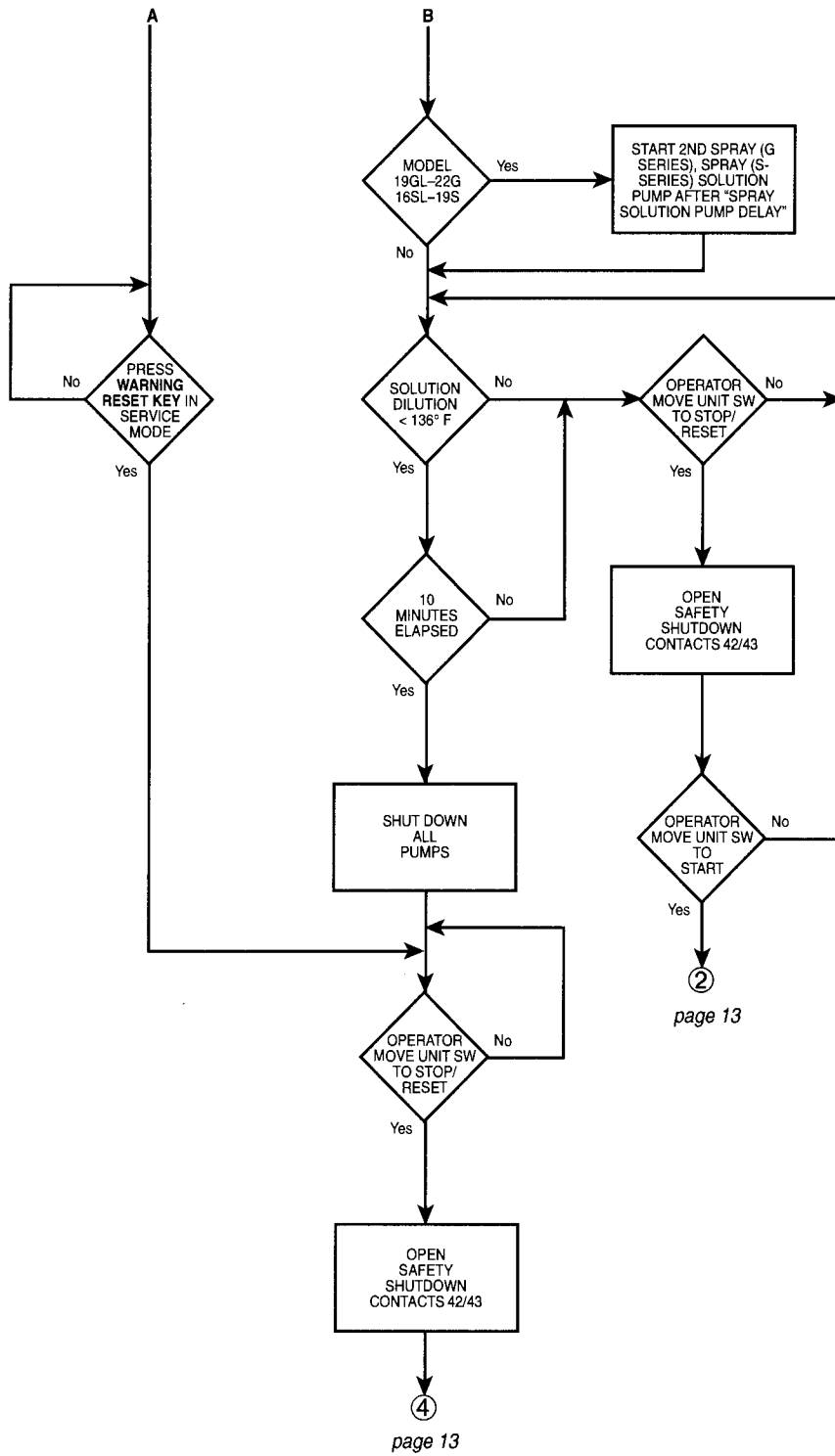

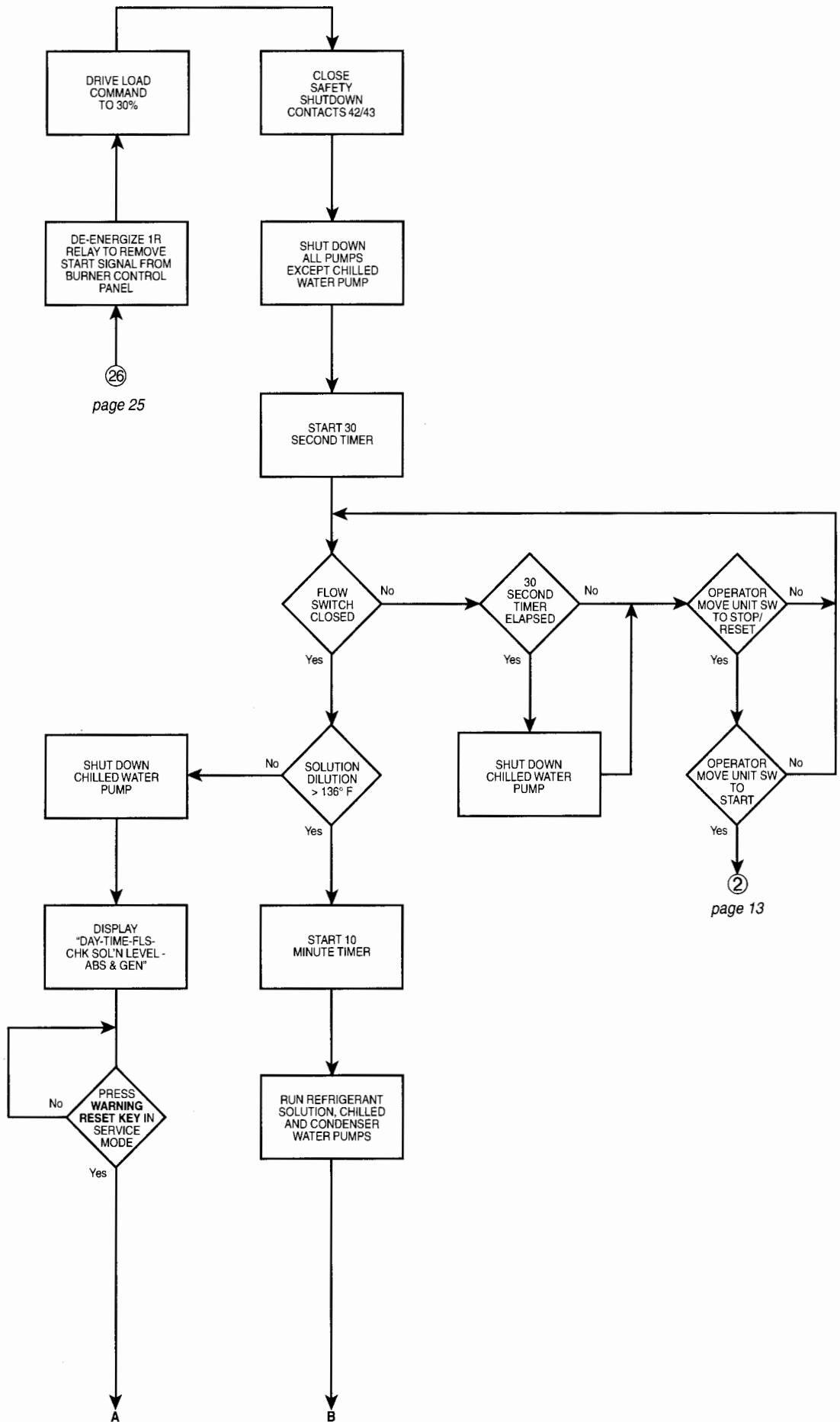

page 25

page 13

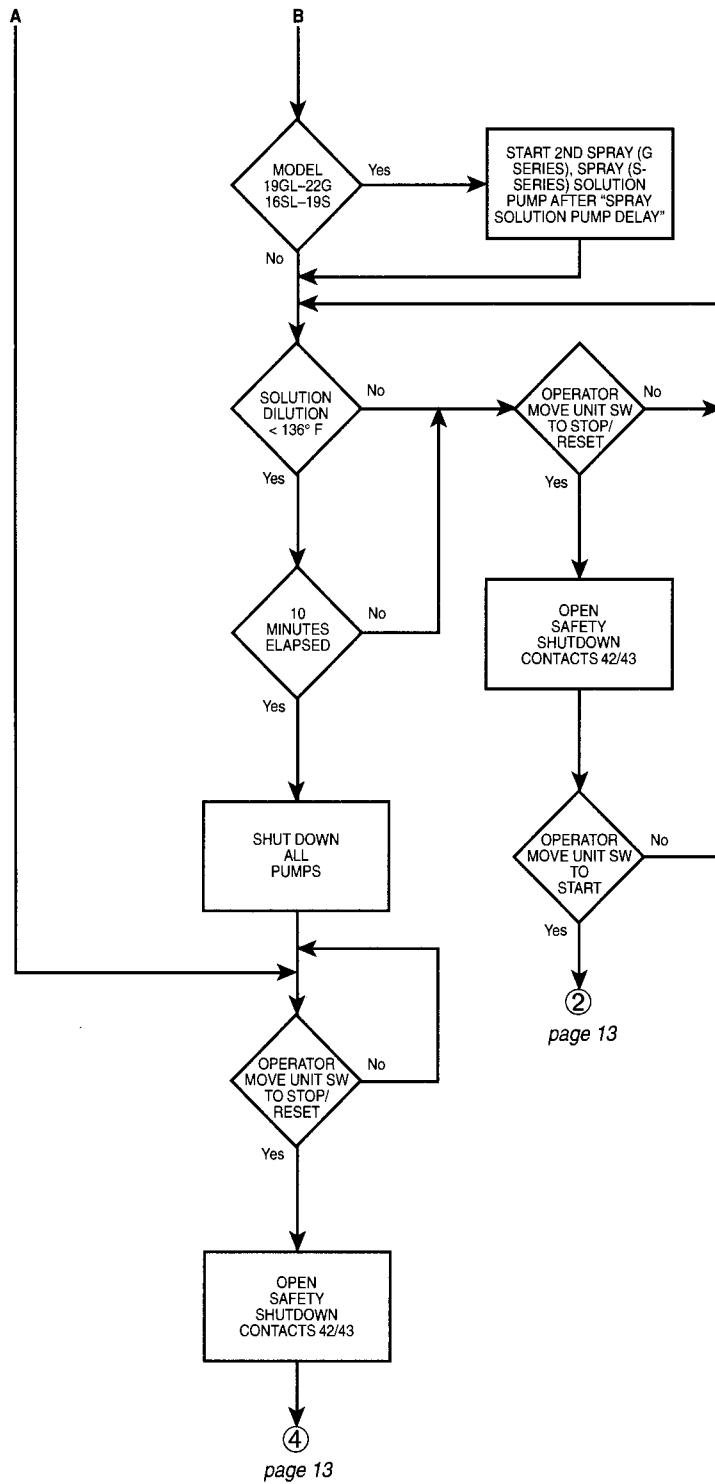

27 page 26

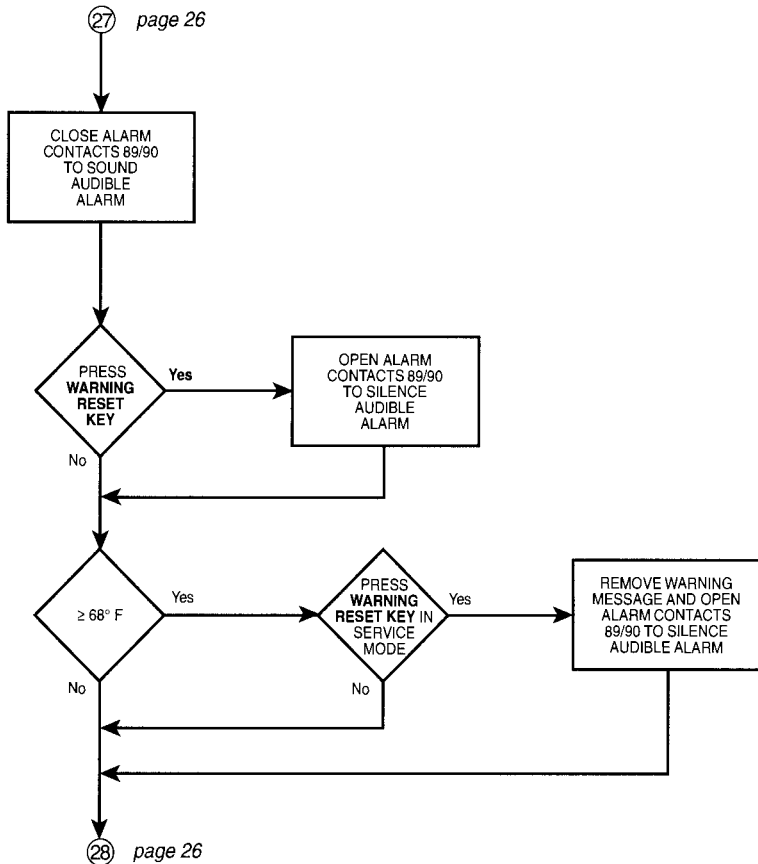

29 page 26

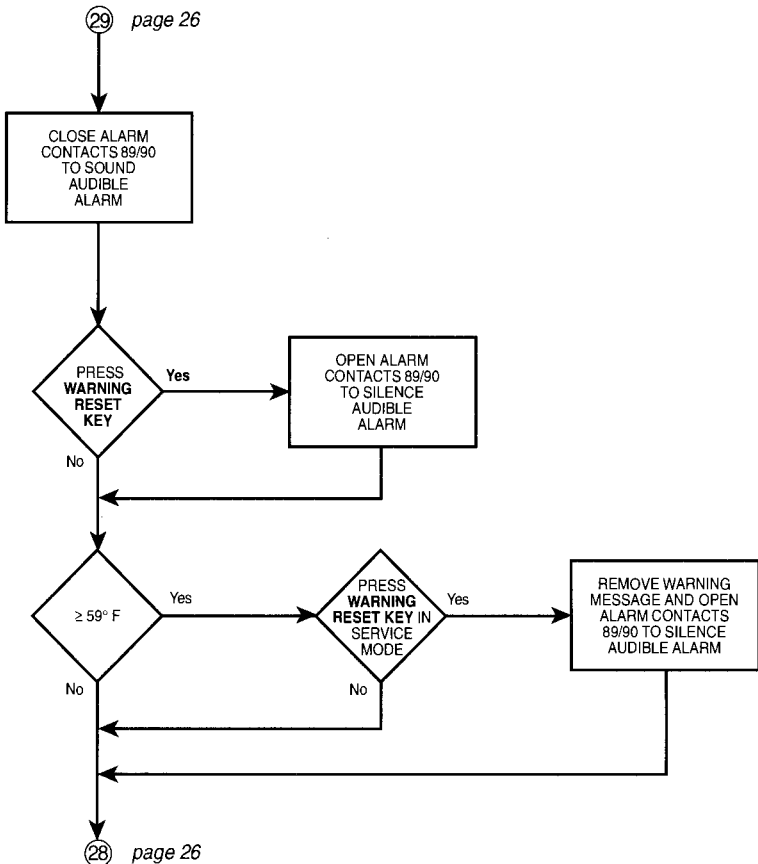

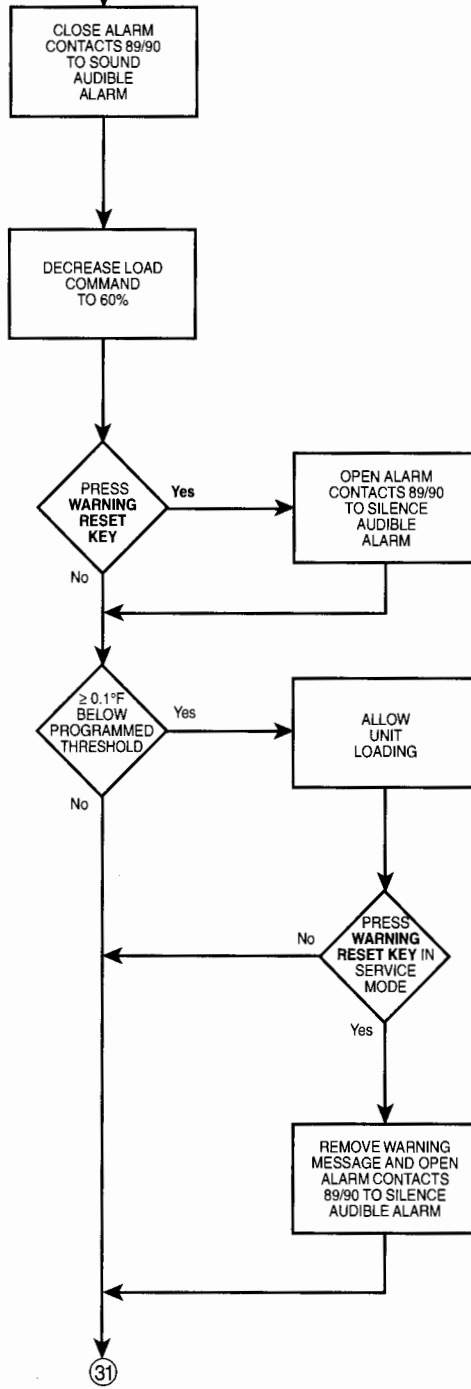

32 page 26

CLOSE ALARM CONTACTS 89/90 TO SOUND AUDIBLE ALARM

PRESS WARNING RESET KEY

OPEN ALARM CONTACTS 89/90 TO SILENCE AUDIBLE ALARM

OVERLOADS CLOSED

PRESS WARNING RESET KEY IN SERVICE MODE

REMOVE WARNING MESSAGE AND OPEN ALARM CONTACTS 89/90 TO SILENCE AUDIBLE ALARM

33

page 26

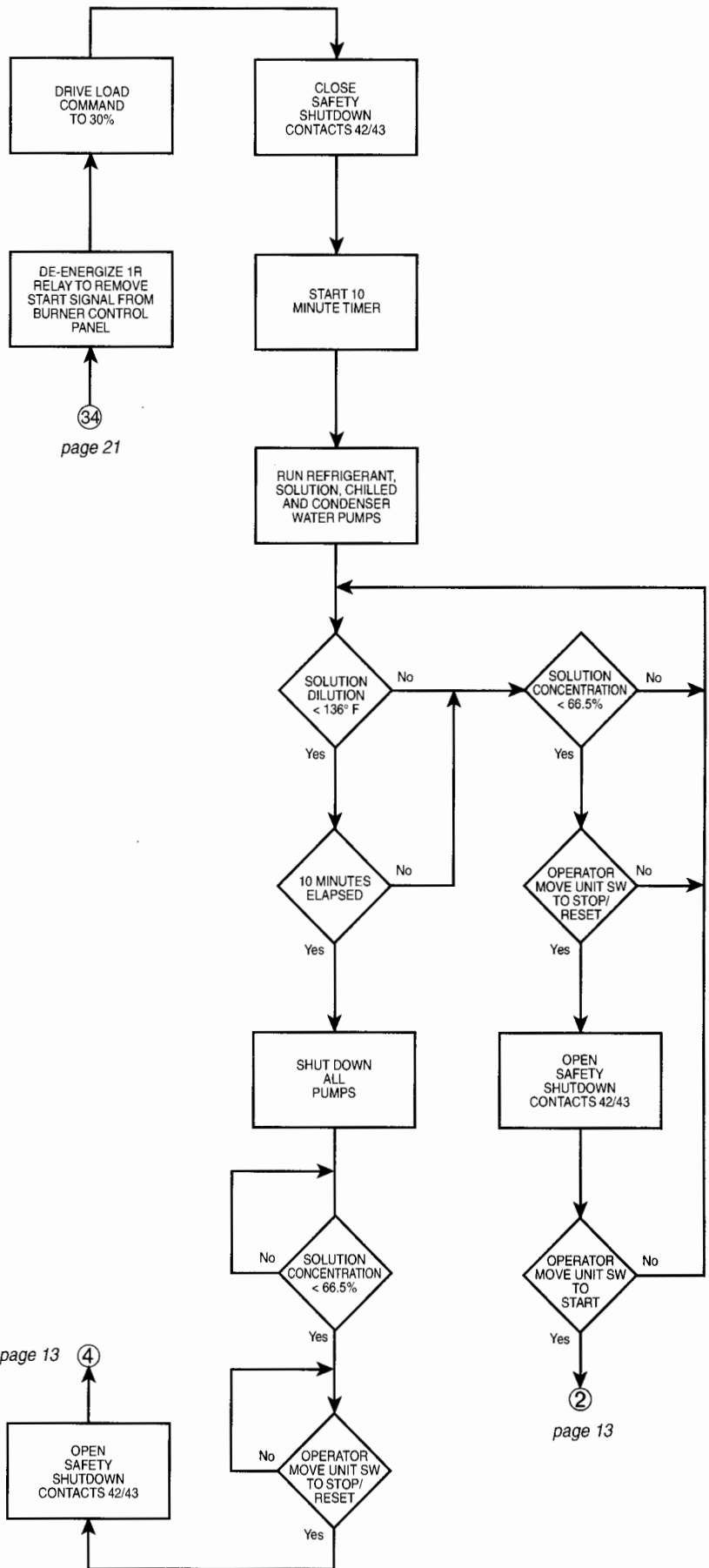

page 21

page 13

page 13

40 page 31

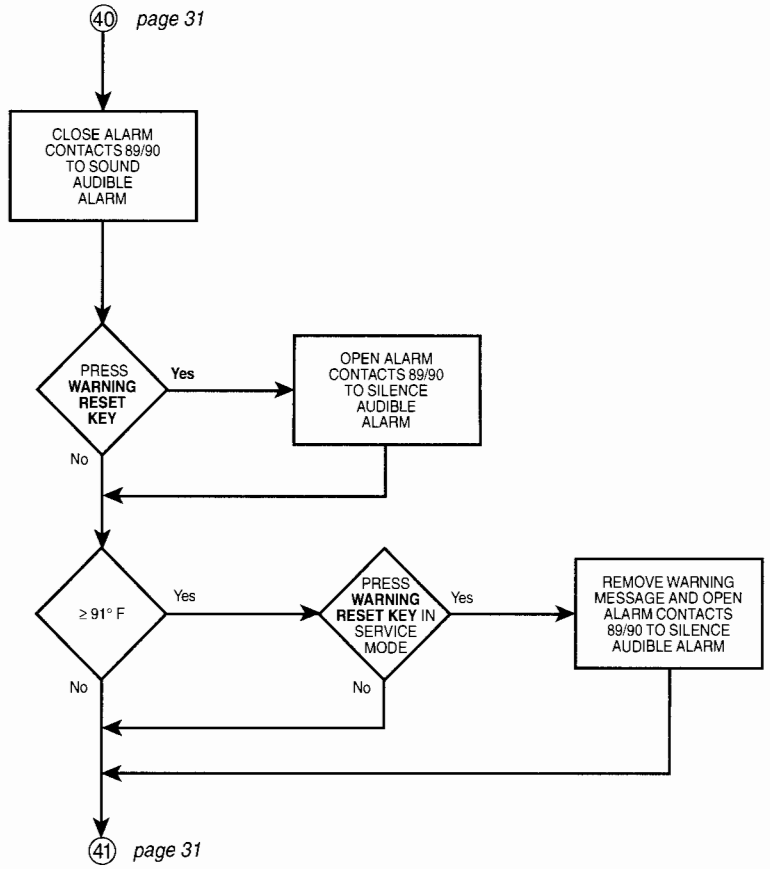

42 page 31

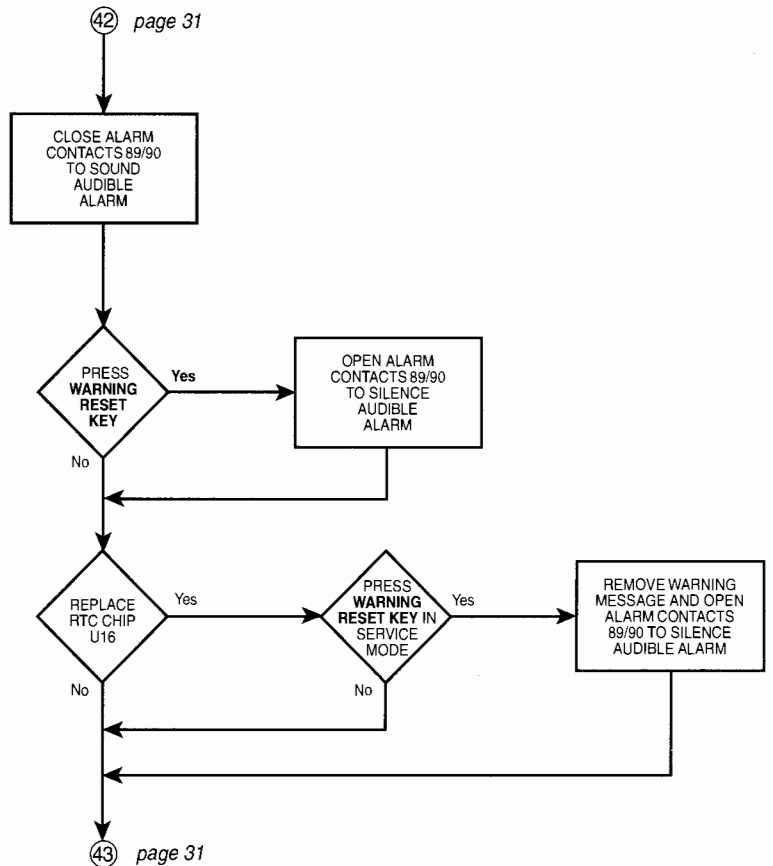

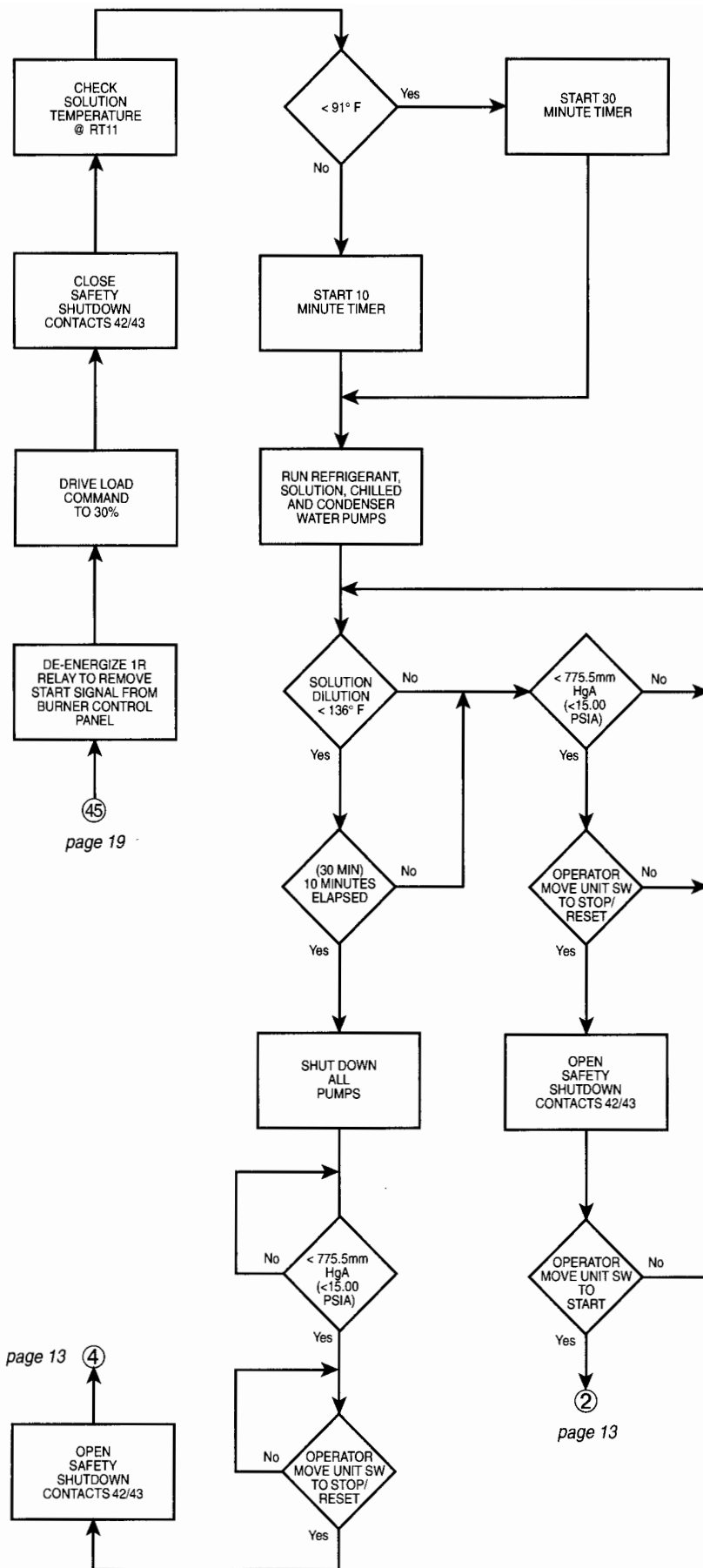

page 19

page 13

page 13

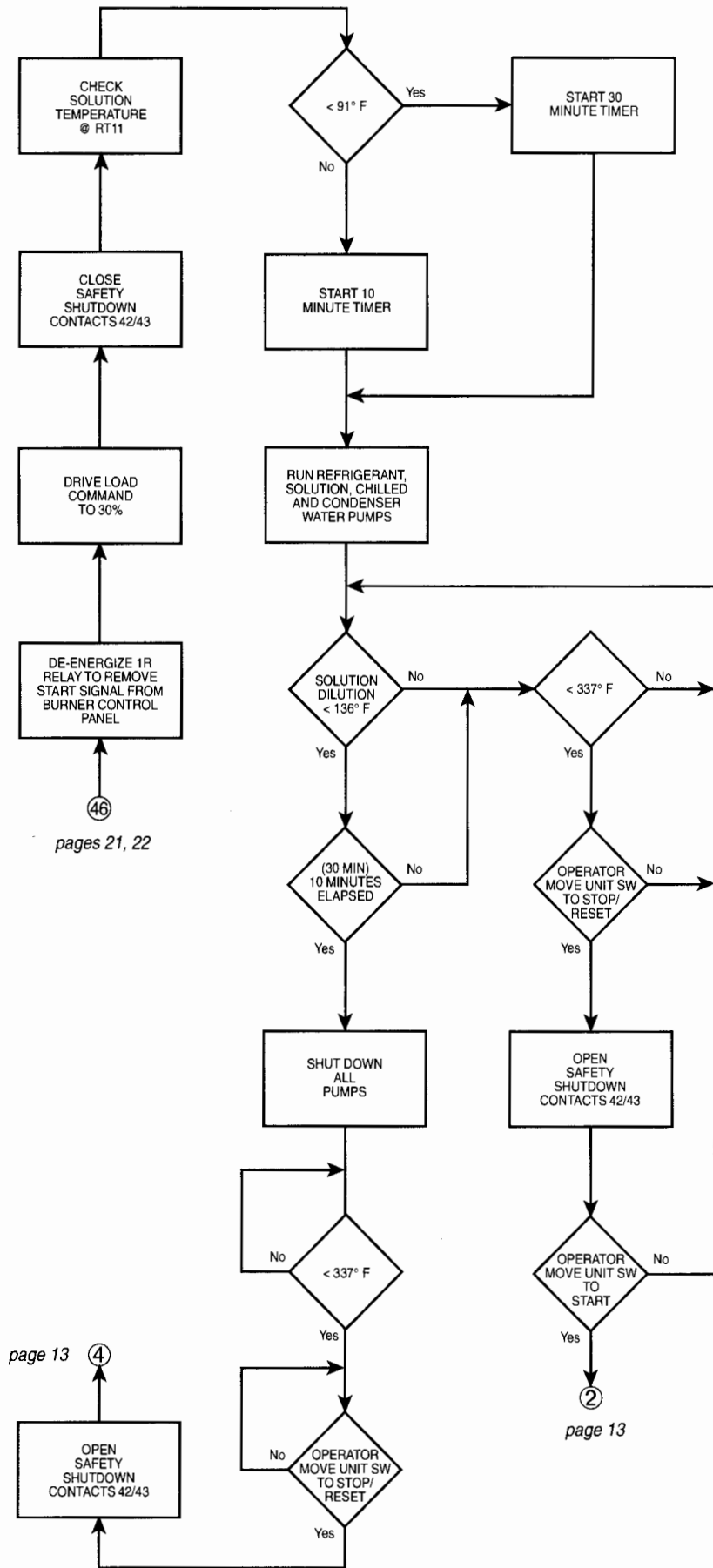

pages 21, 22

page 13 ④

page 13 ②

UNIT OPERATION

STEAM-FED COOLING MODE (Equipped with Automatic Purge System)

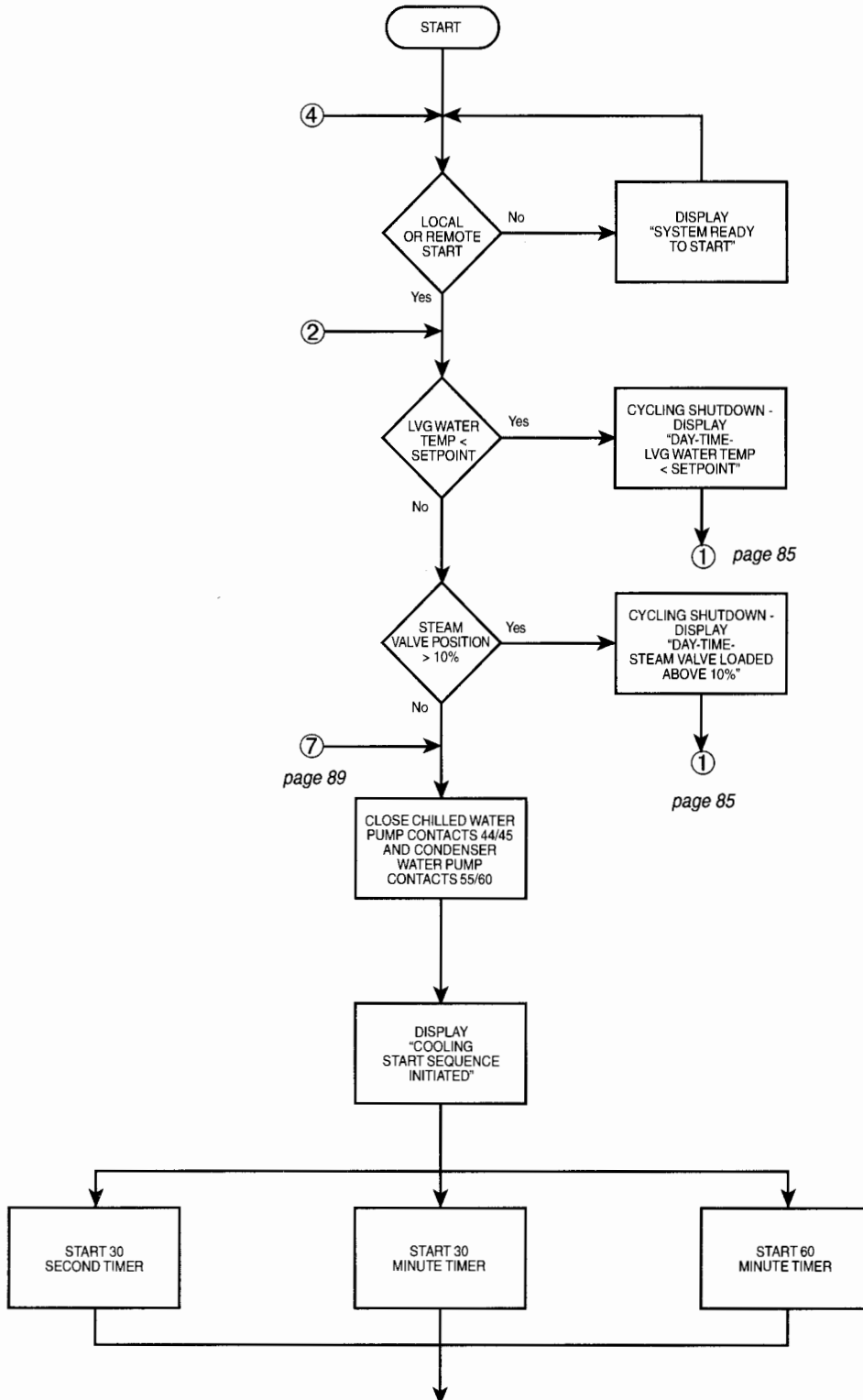

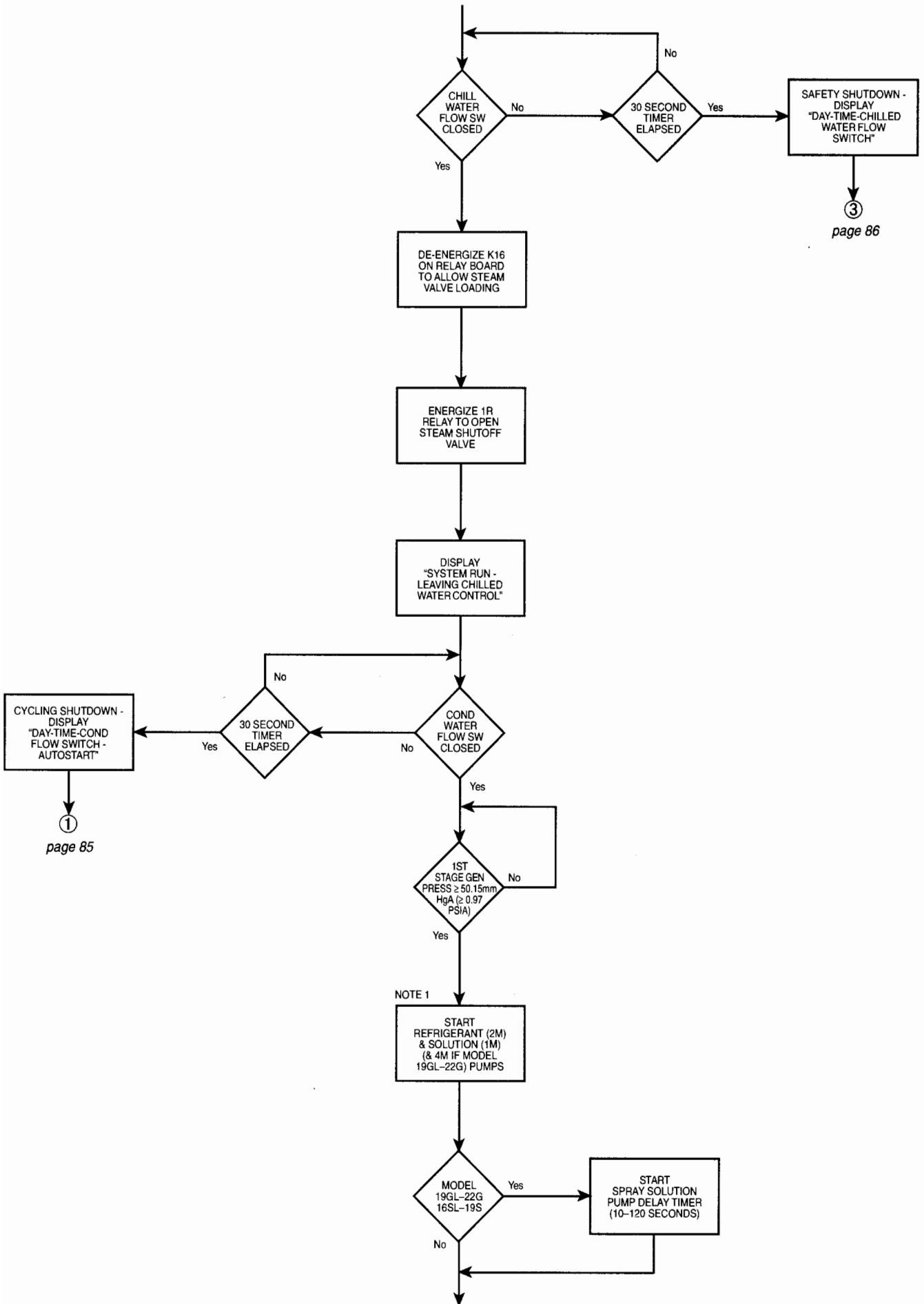

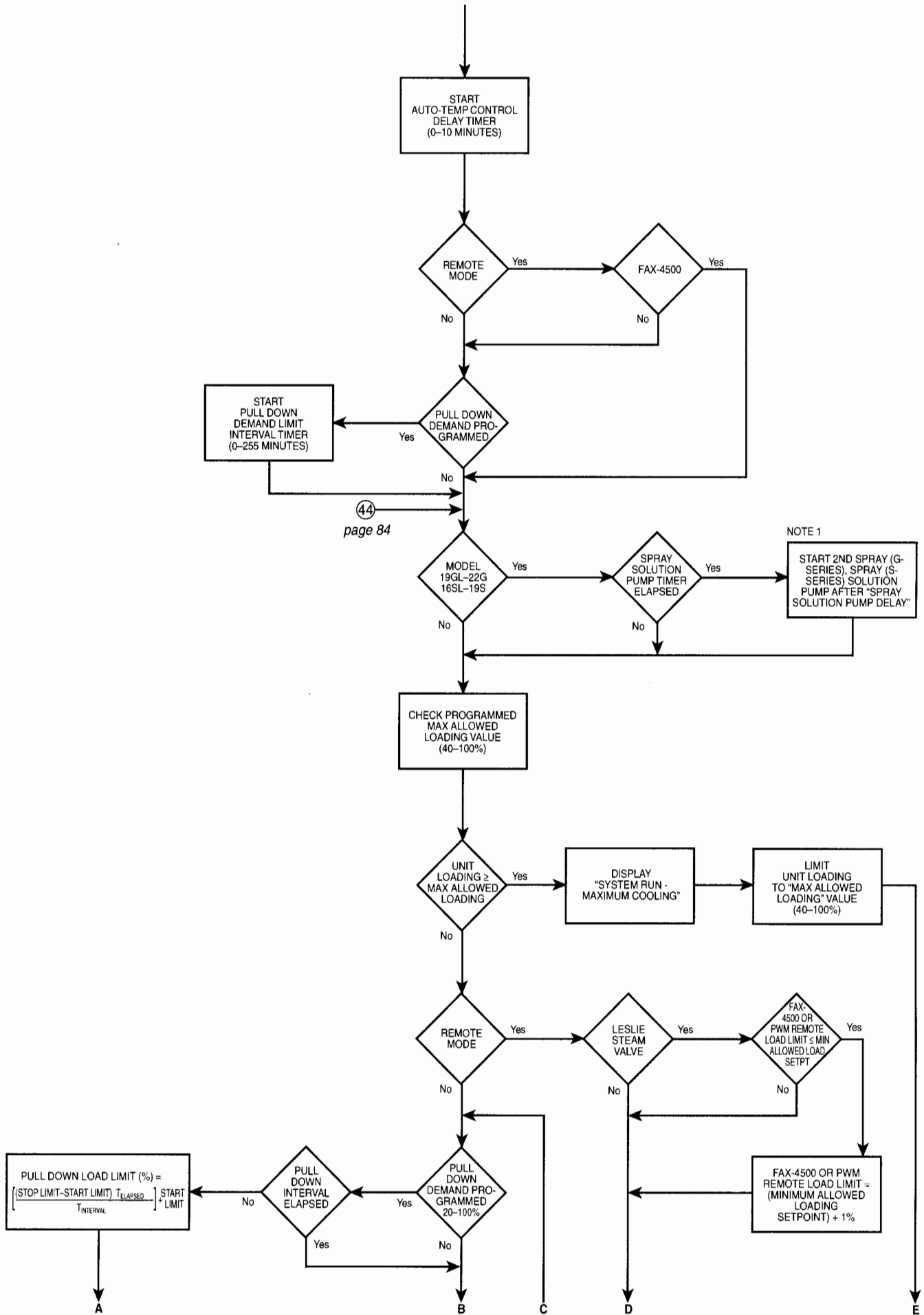

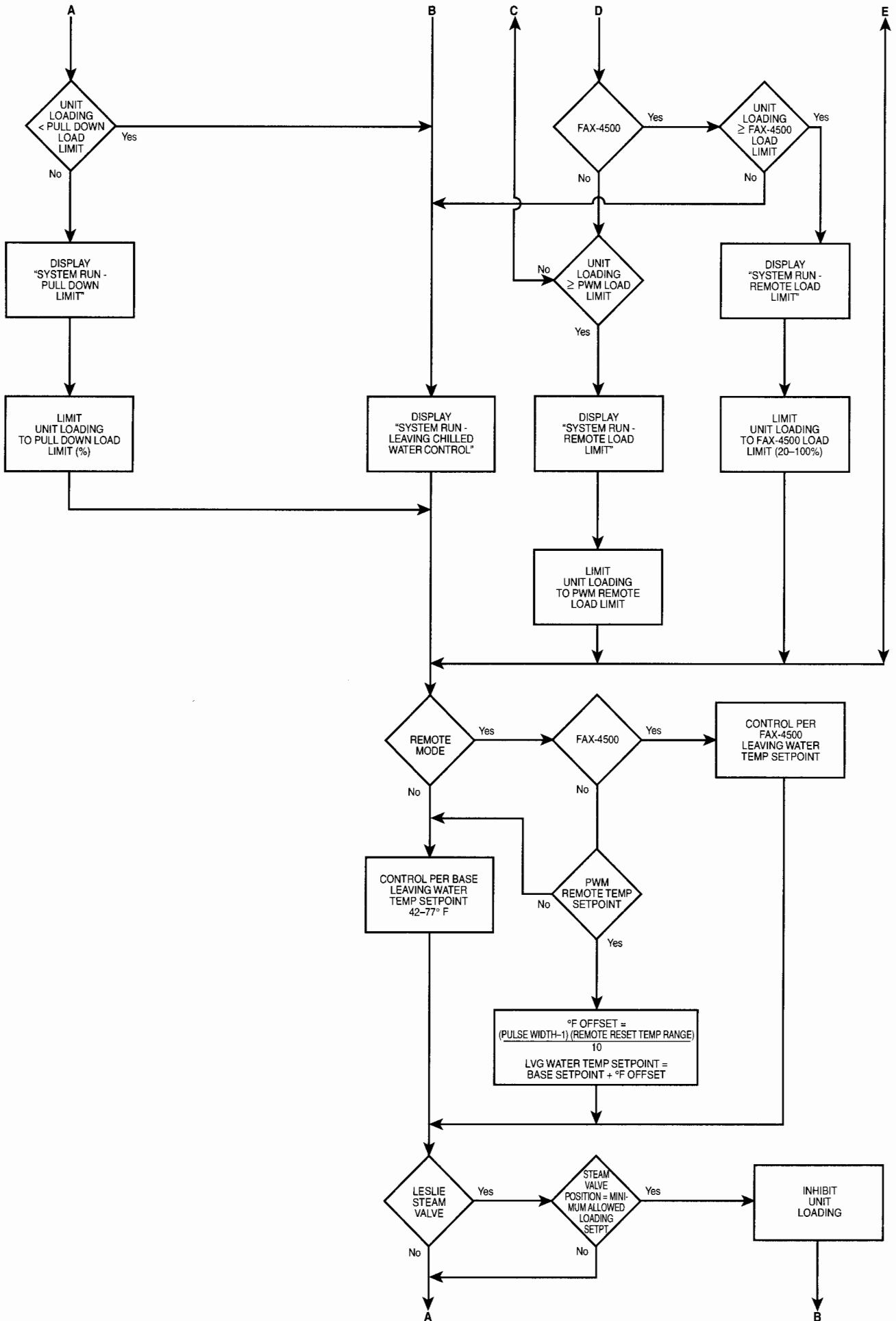

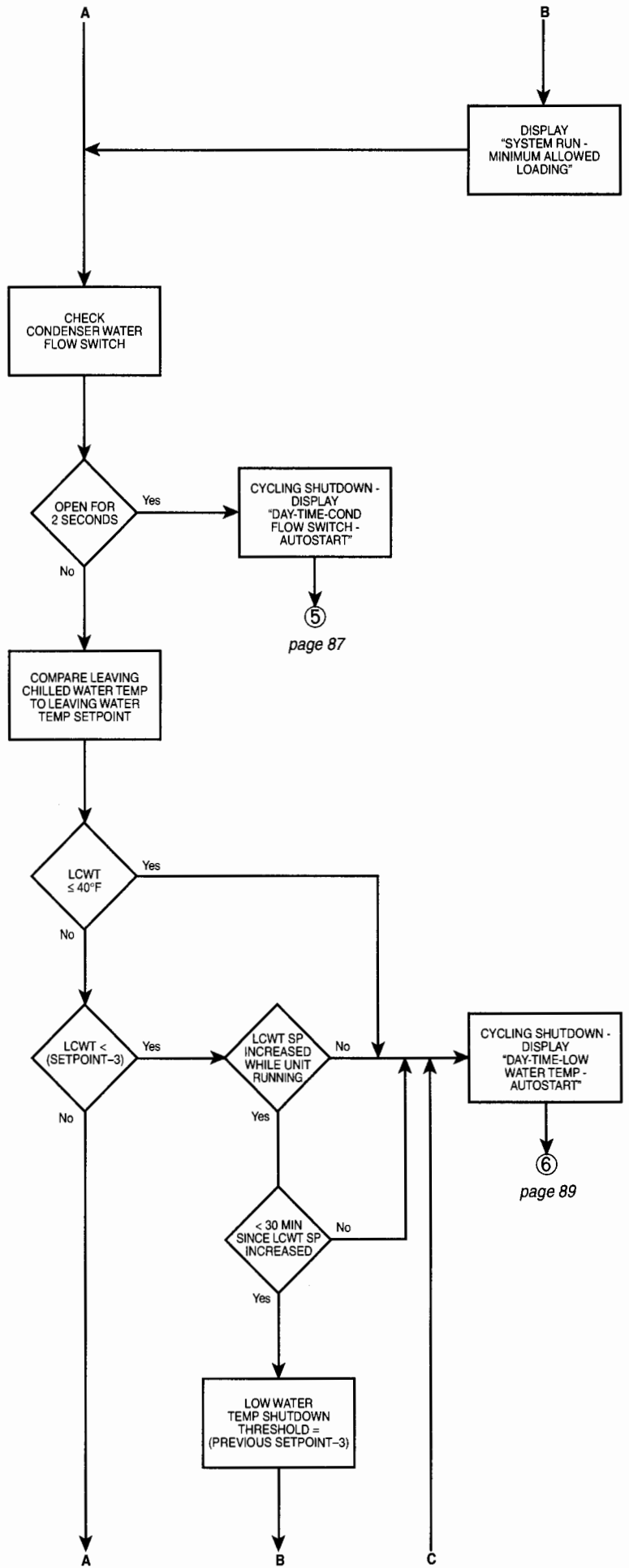

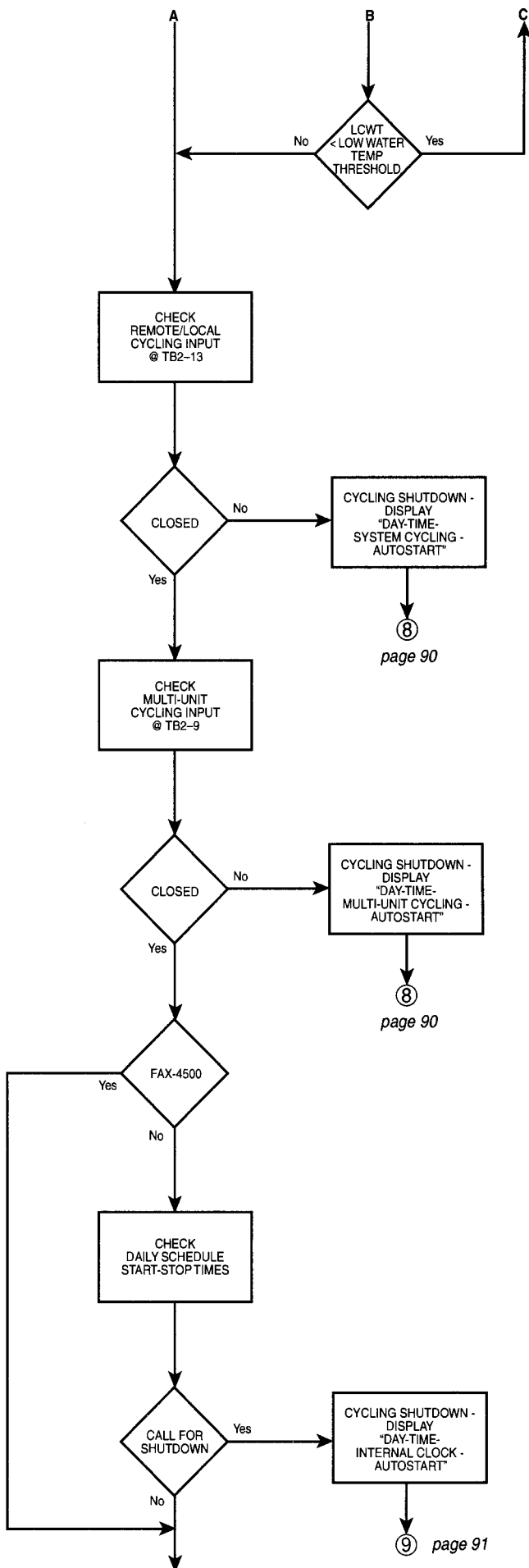

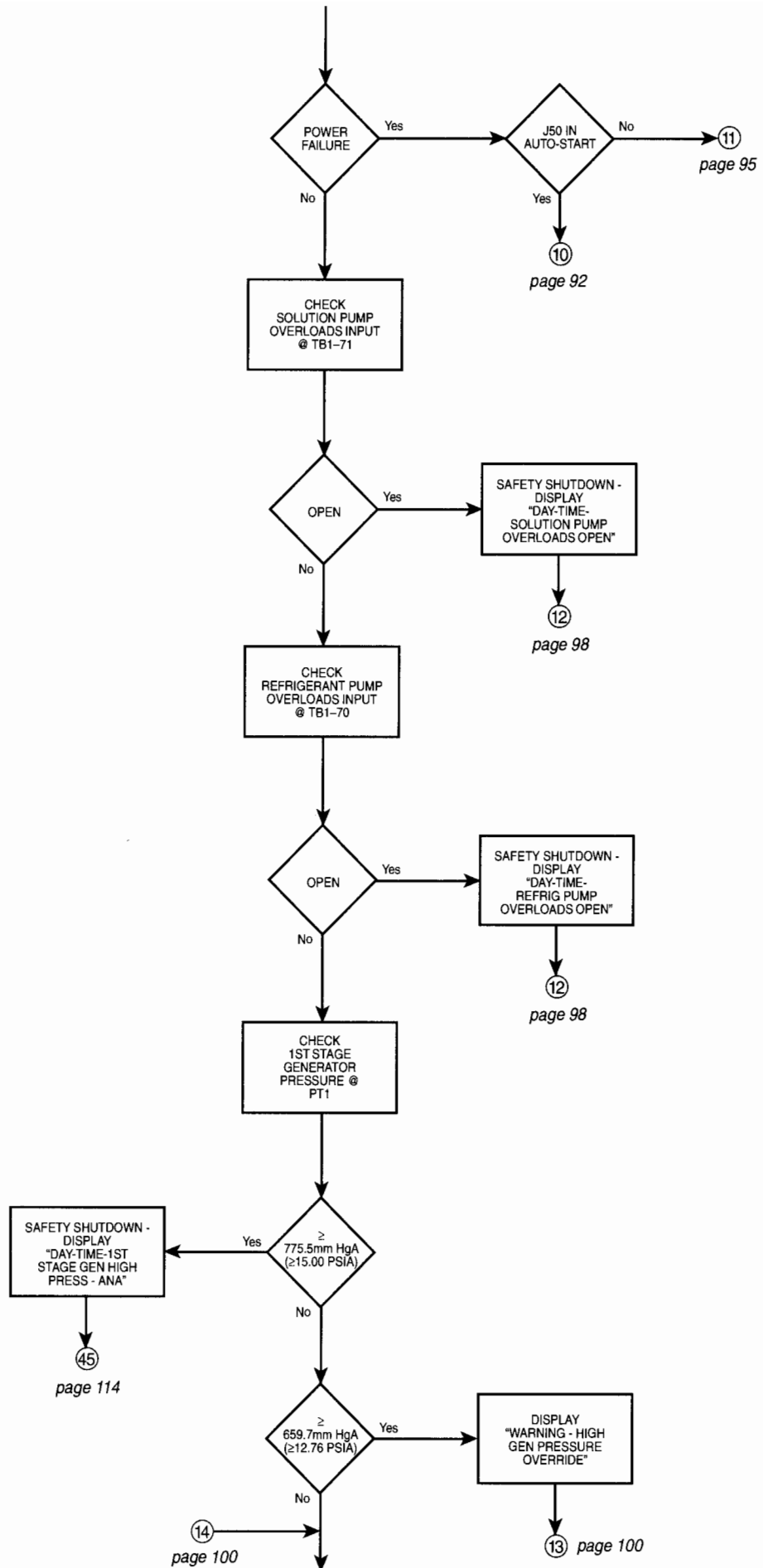

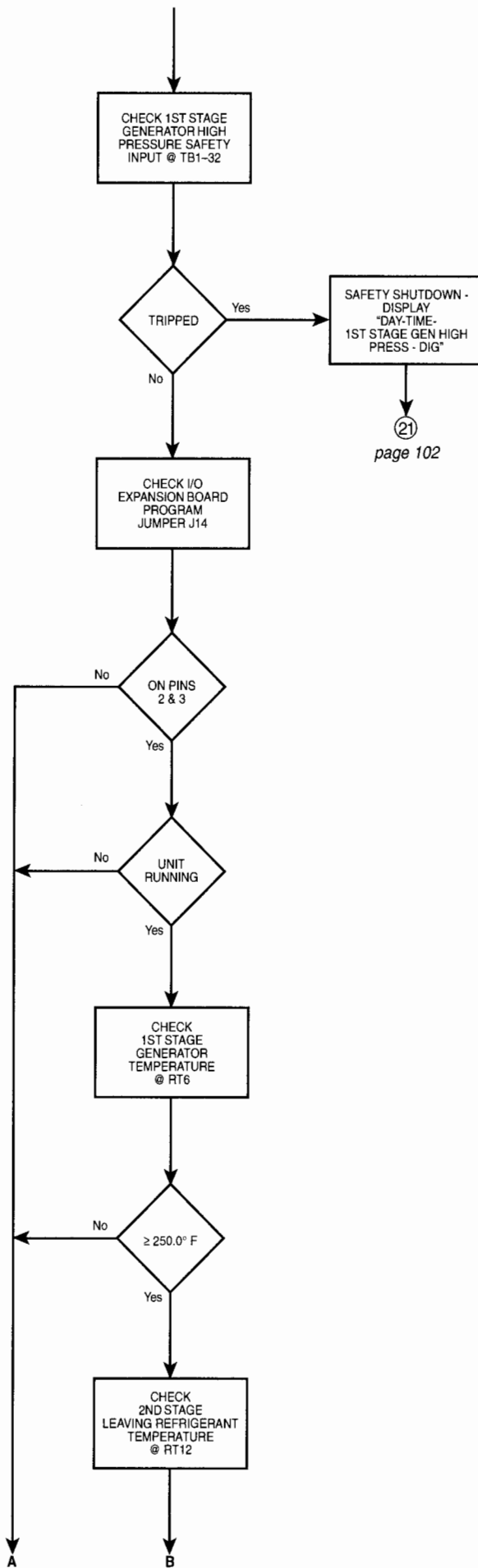

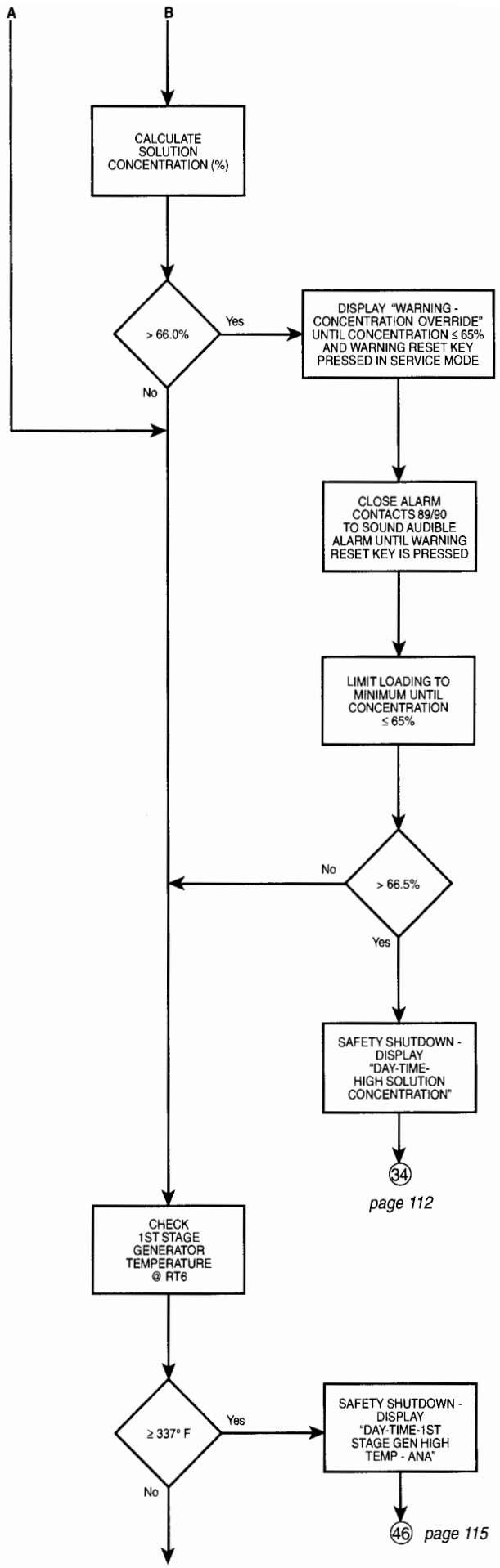

page 112

page 115

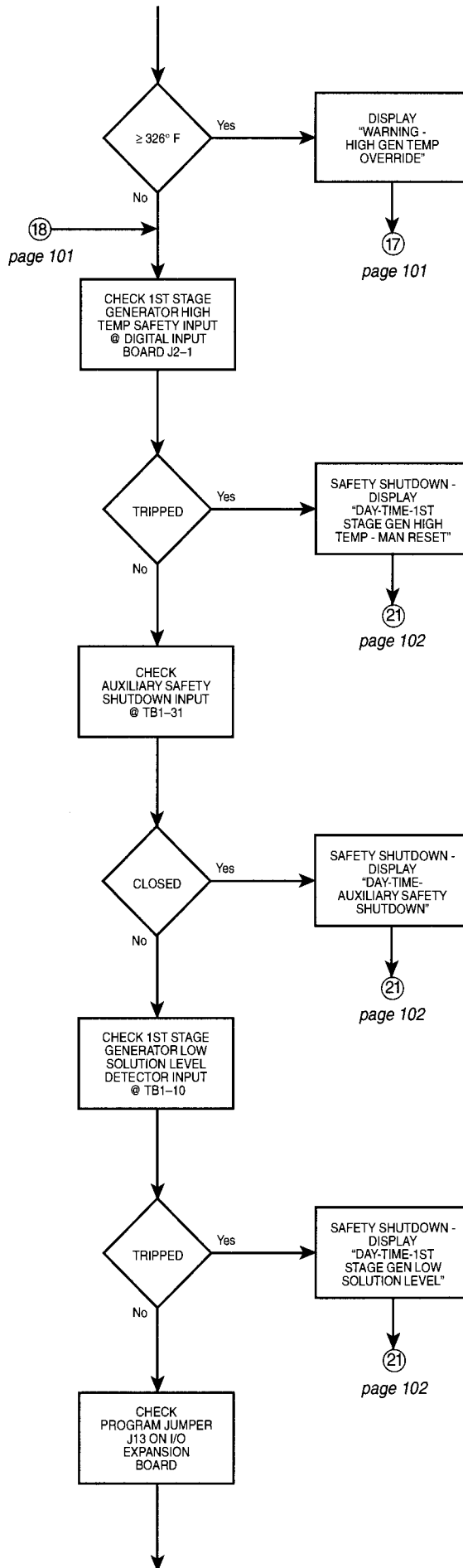

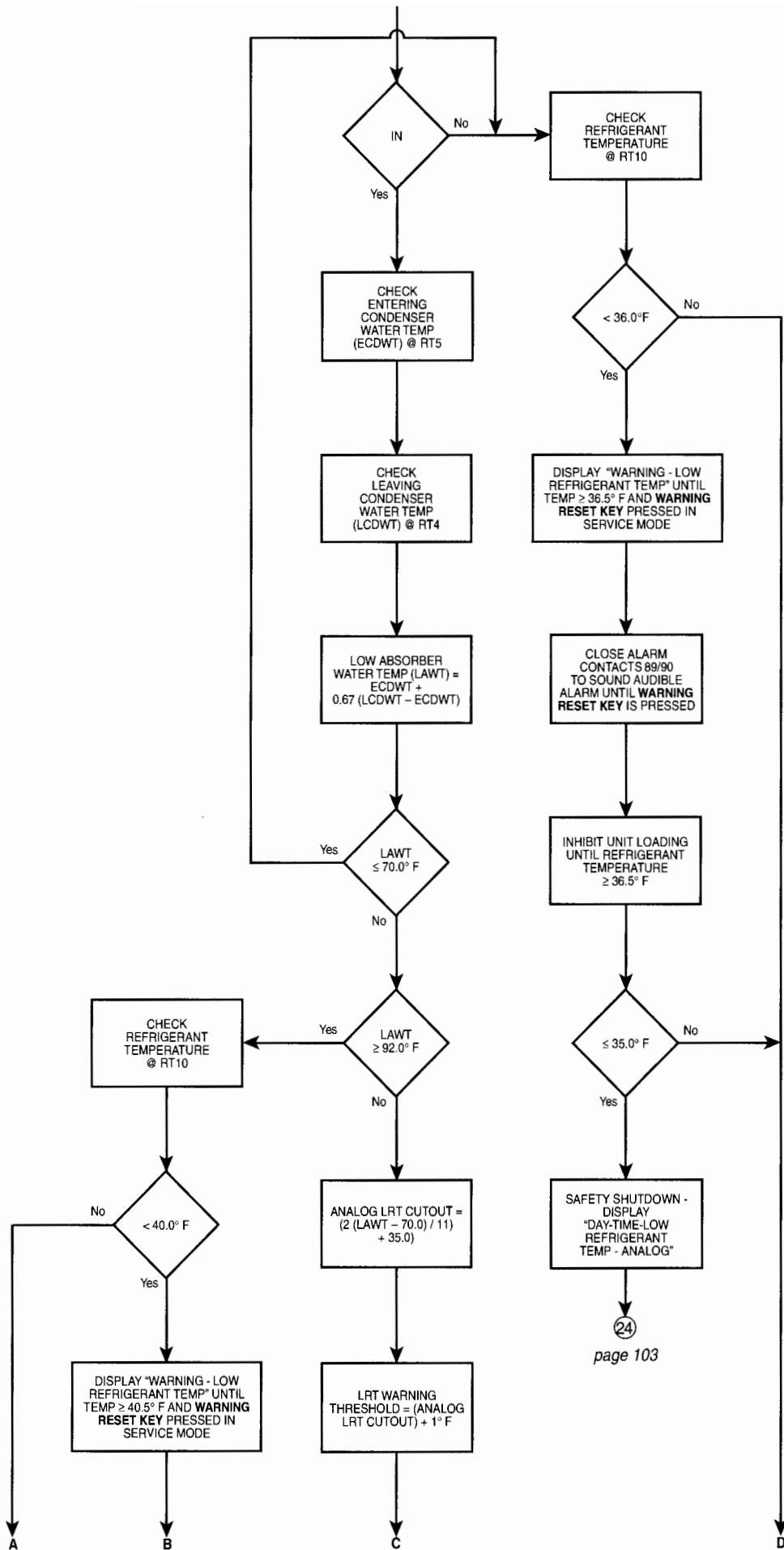

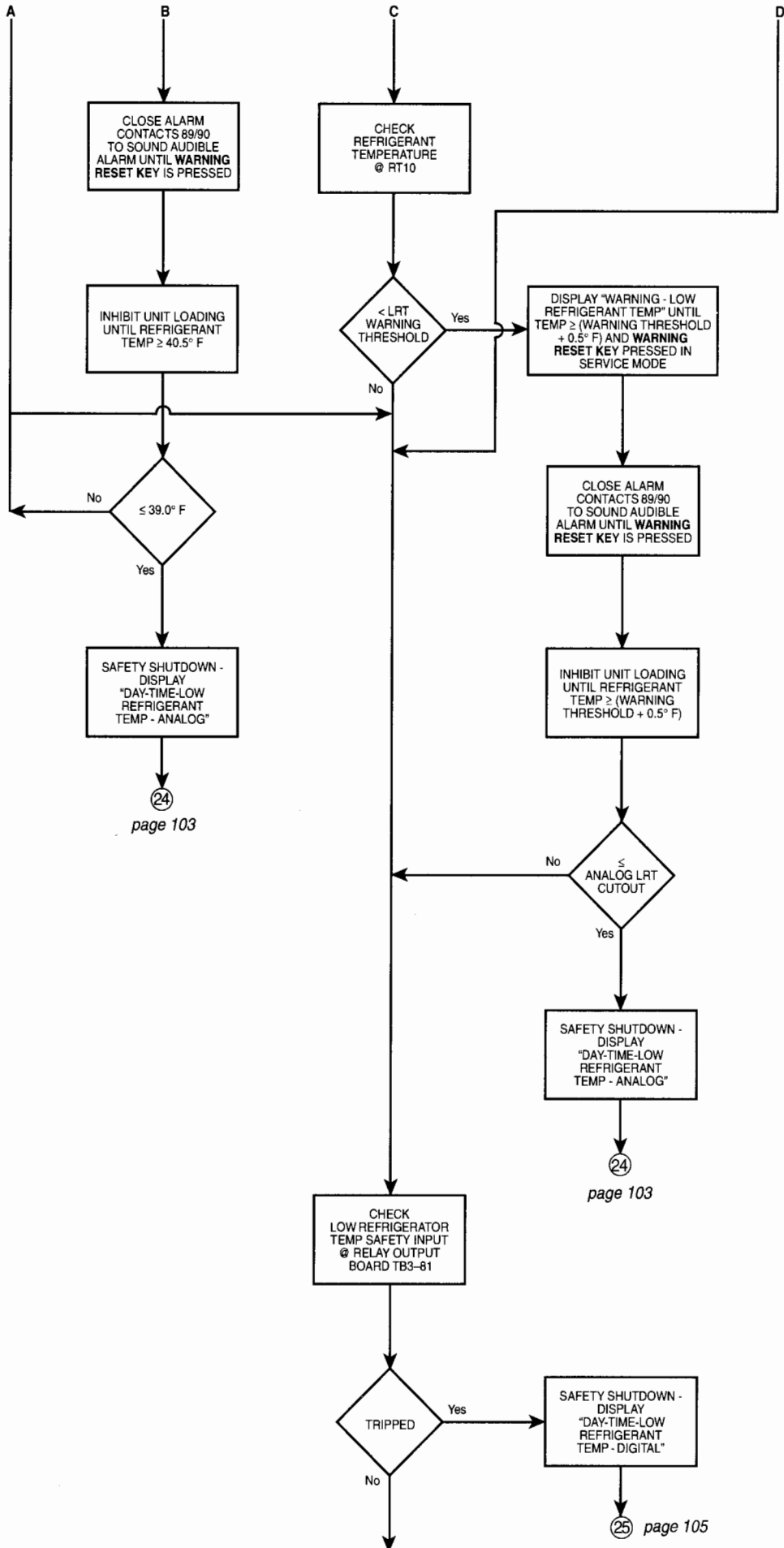

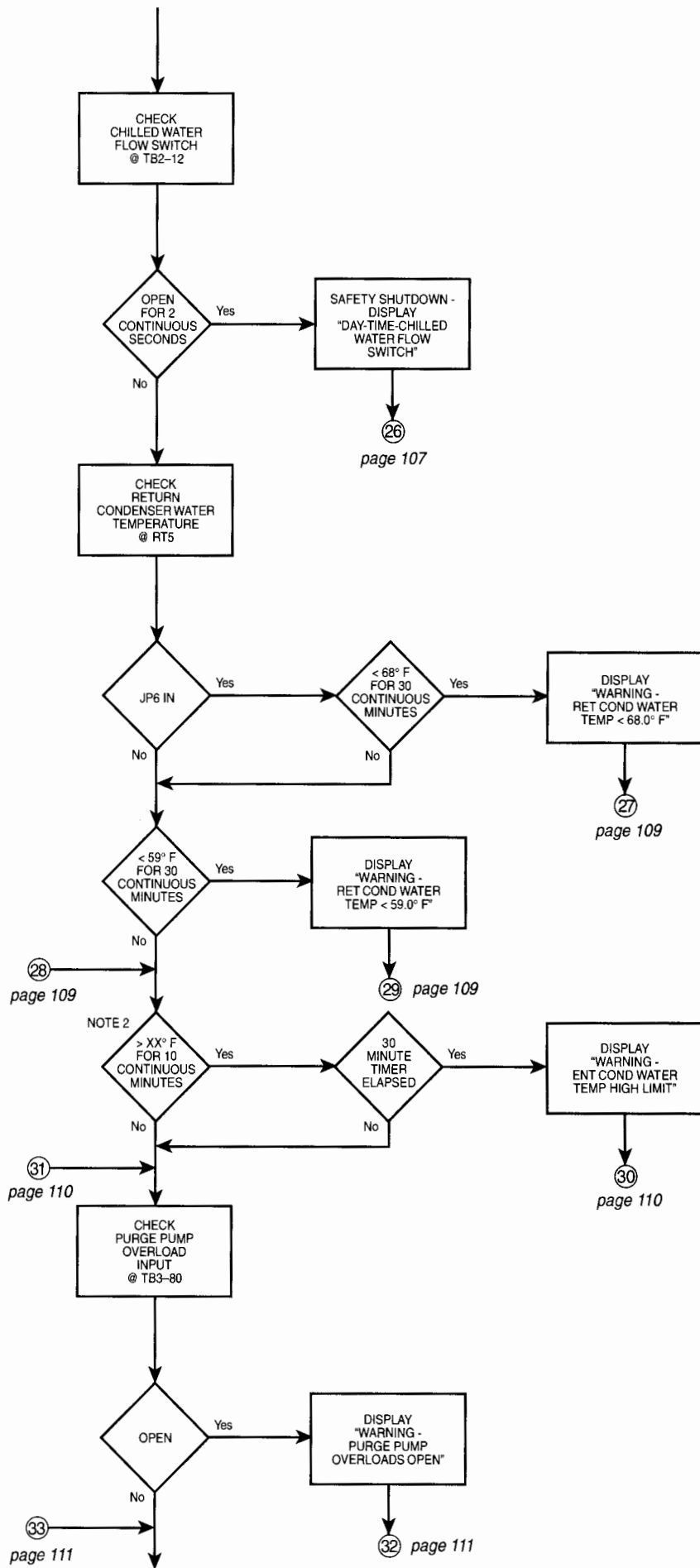

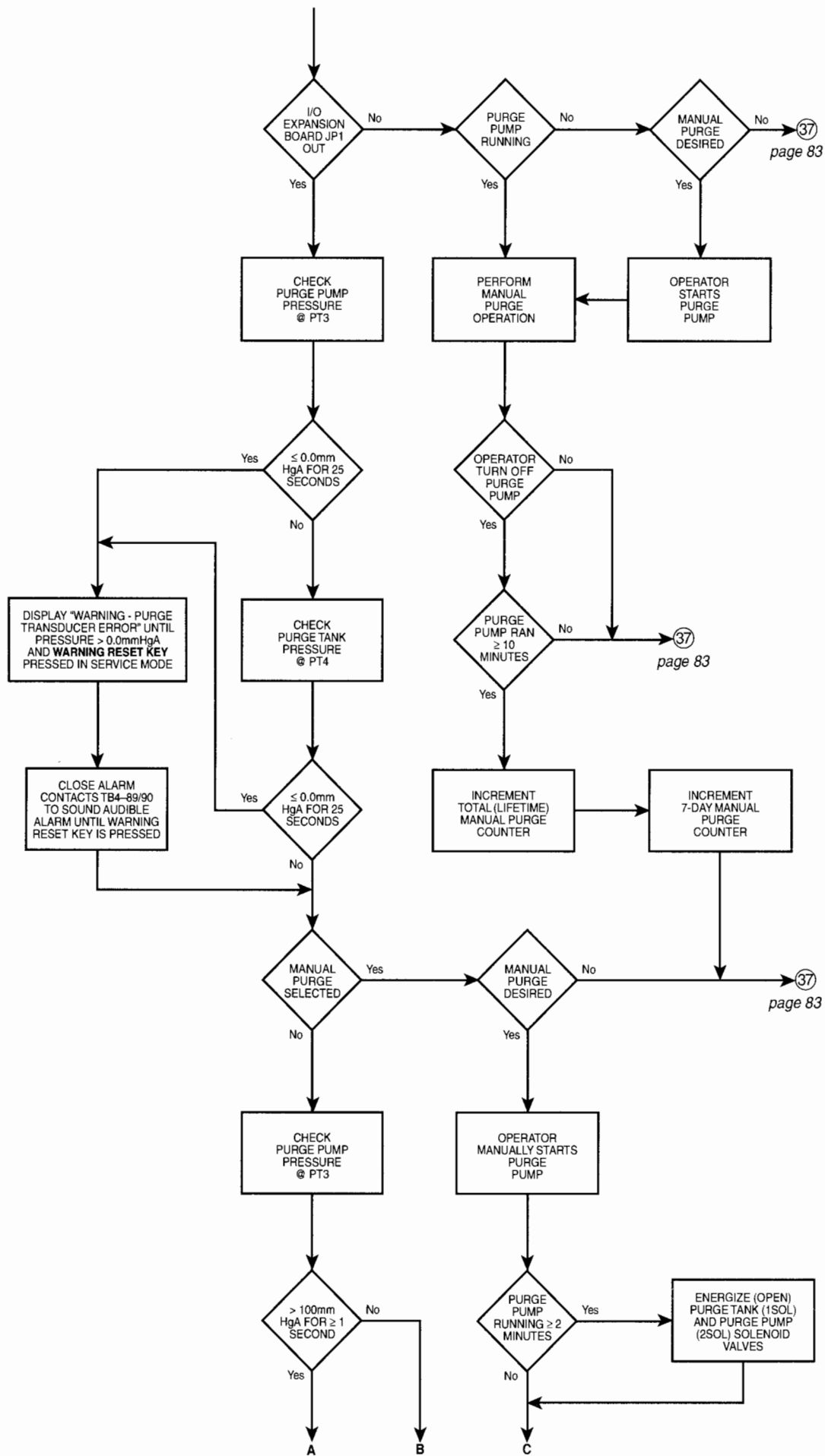

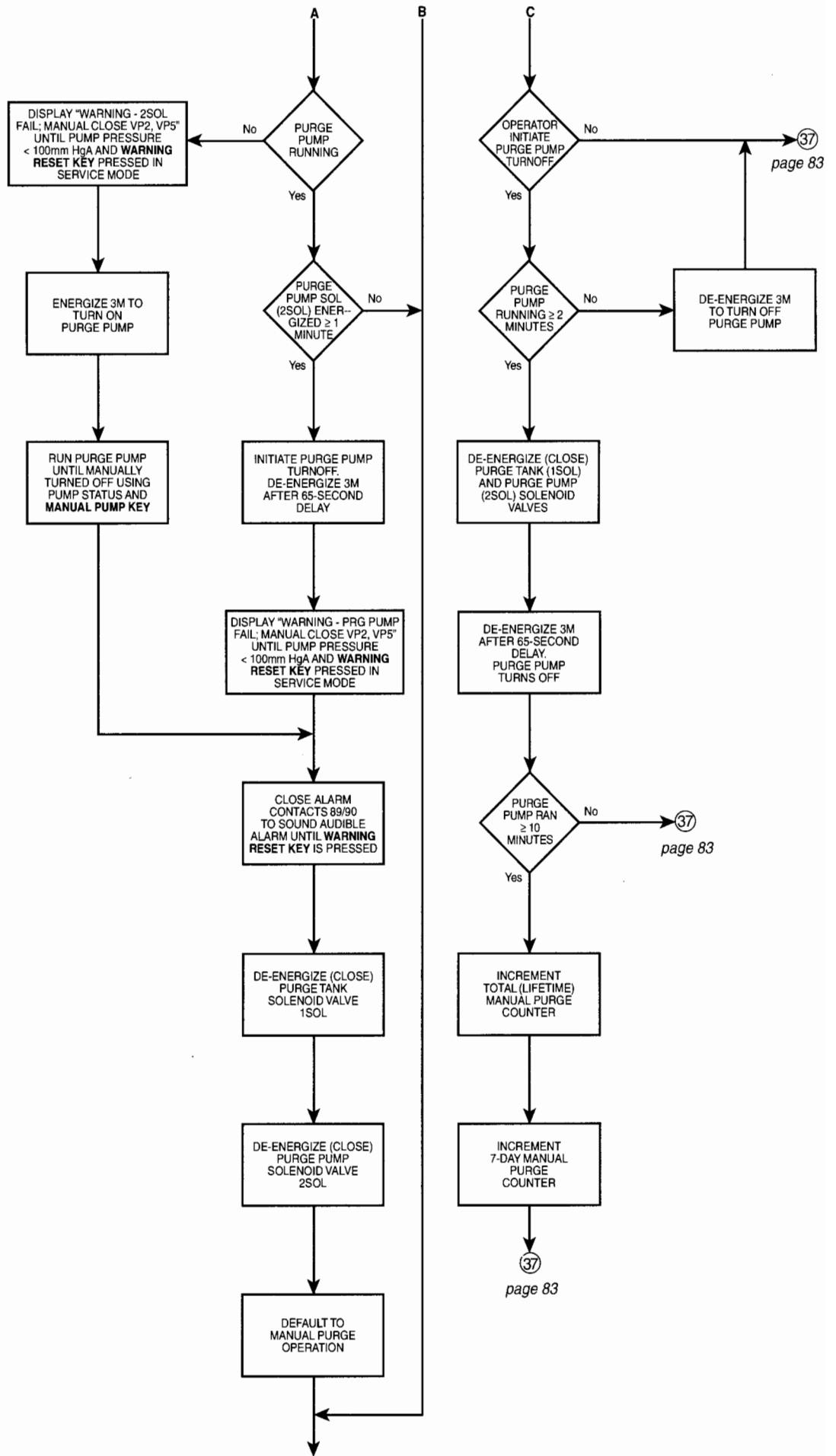

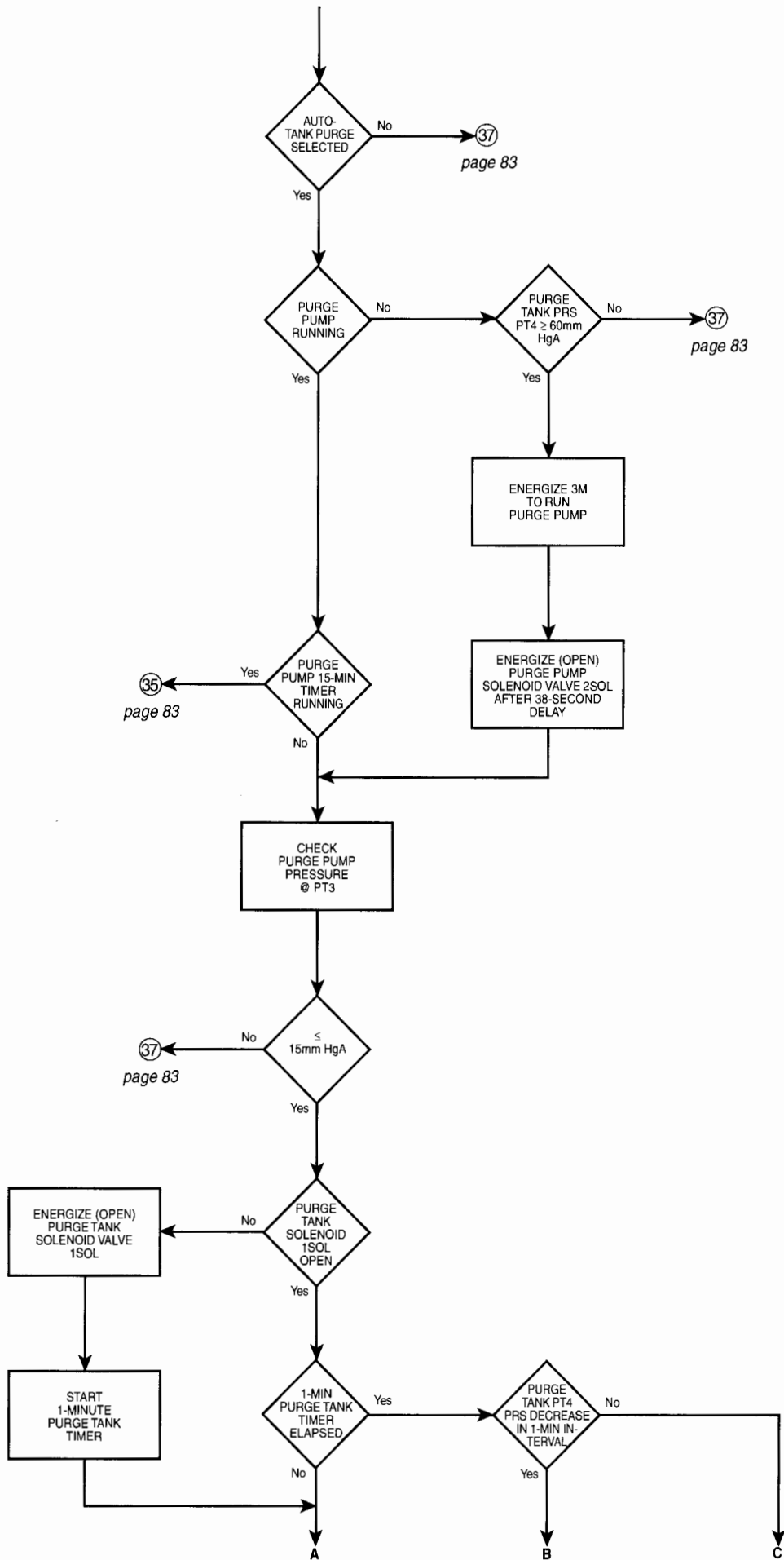

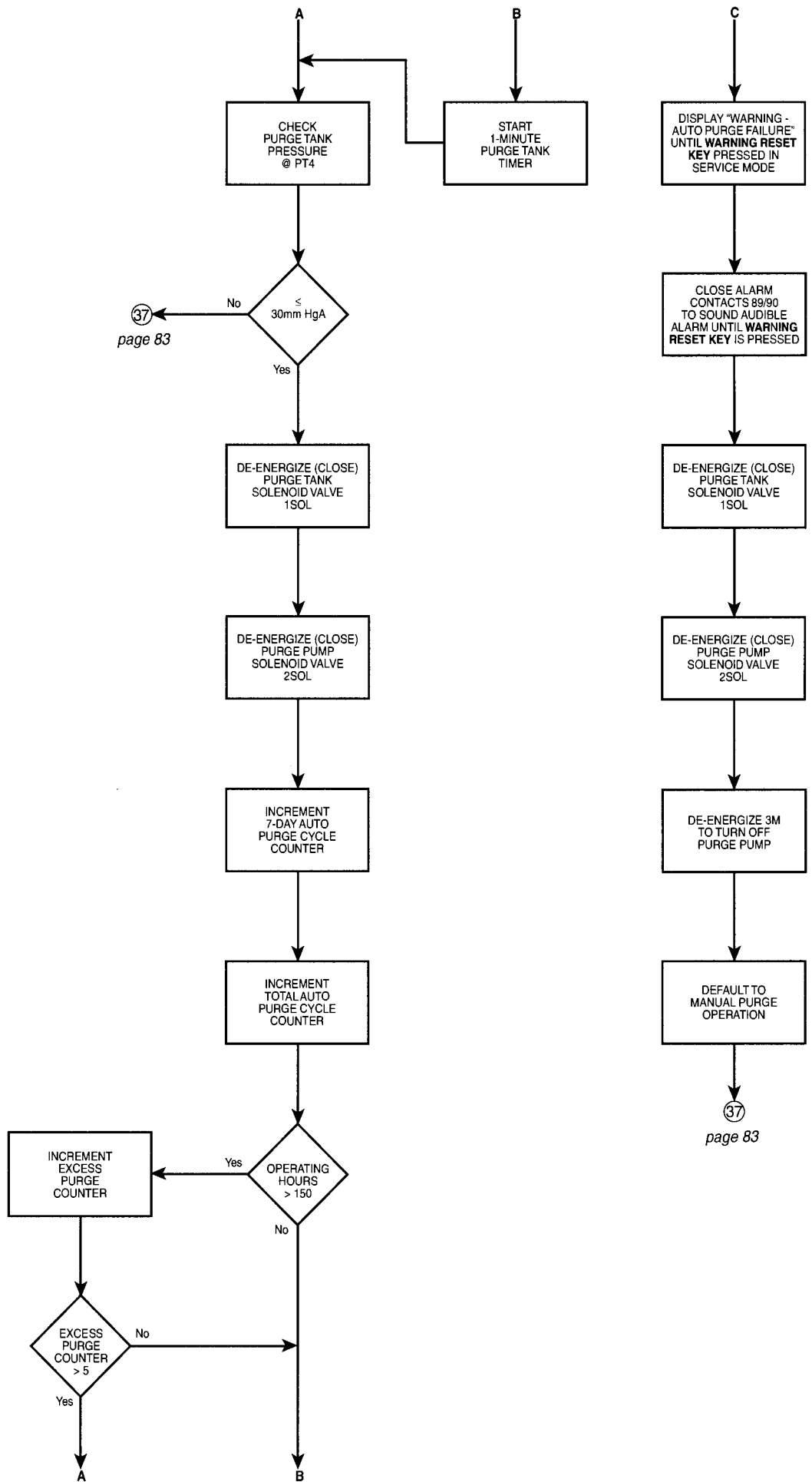

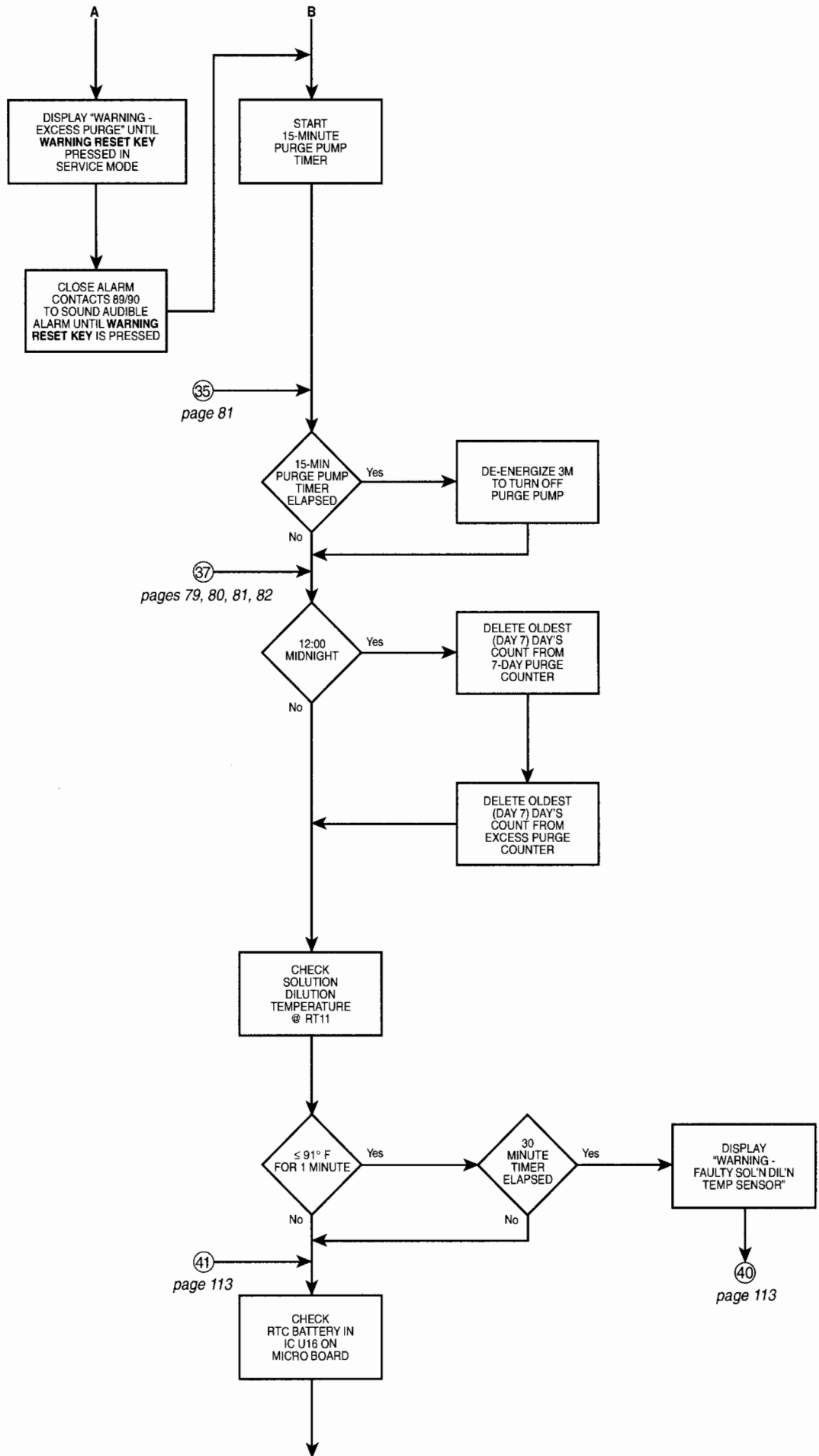

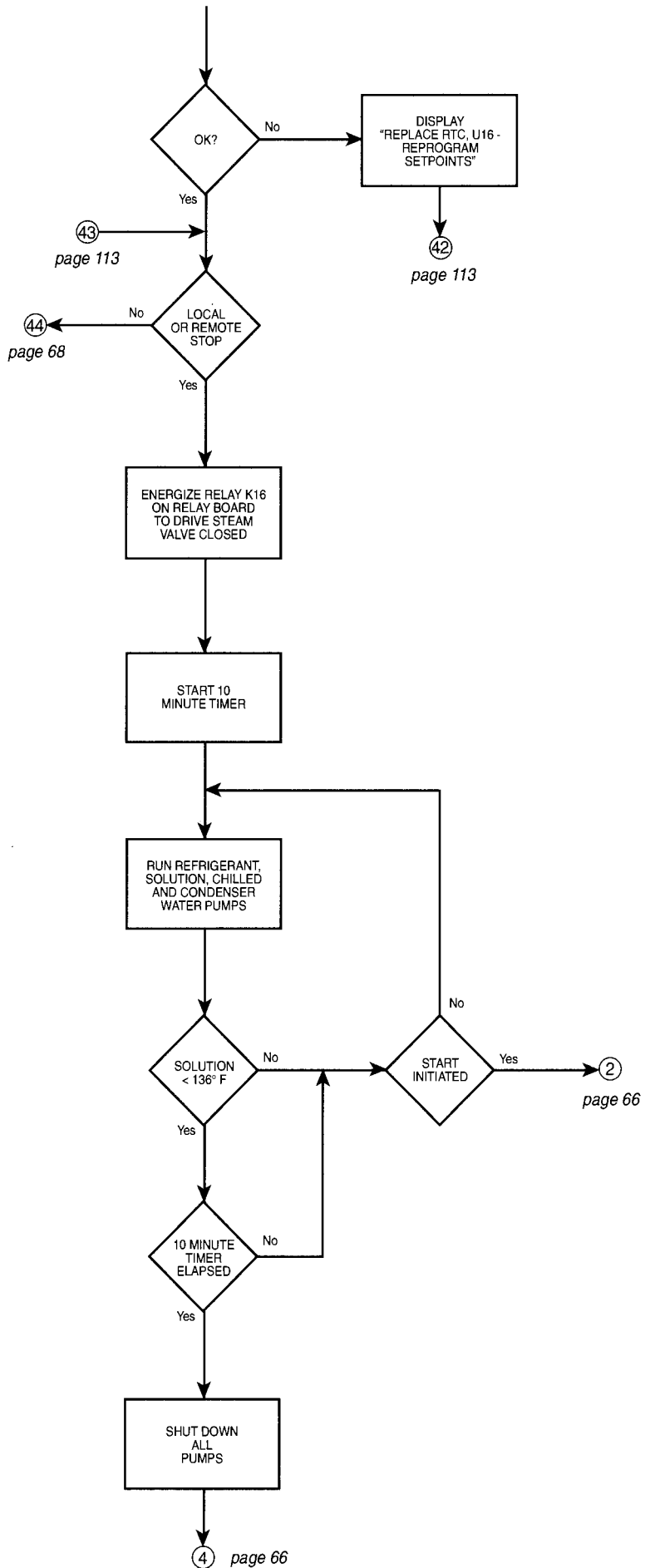

NOTES:

1. If unit is restarted while a dilution cycle is in progress, all pumps will continue to run during "Start Sequence Initiated."
2. This value is a variable that is programmed at the YORK factory. The unit design determines the value. Refer to Control Center Service Manual 155.17-M2.
3. If chilled water flow switch, solution or refrigerant pump overloads open or a low refrigerant temperature shutdown occurs while a dilution cycle is in progress, the dilution cycle will be terminated.

SAFETY SHUTDOWN CYCLING SHUTDOWN AND ALARM

UNIT OPERATION SUBROUTINES

STEAM-FED COOLING MODE (Equipped with Automatic Purge System)

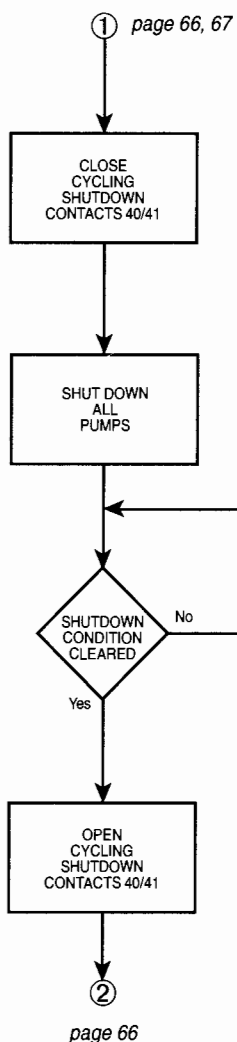

CLOSE
CYCLING
SHUTDOWN
CONTACTS 42/43

SHUT DOWN
ALL
PUMPS

SHUTDOWN
CONDITION
CLEARED

No

Yes

OPERATOR
MOVE UNIT SW
TO STOP/
RESET

No

Yes

OPEN
SAFETY
SHUTDOWN
CONTACTS 42/43

⑤ page 70

ENERGIZE RELAY K16
ON RELAY BOARD
TO DRIVE STEAM
VALVE CLOSED

CLOSE
CYCLING
SHUTDOWN
CONTACTS 40/41

CHECK
SOLUTION
TEMPERATURE
@ RT11

< 91° F

START 30
MINUTE TIMER

START 10
MINUTE TIMER

RUN REFRIGERANT,
SOLUTION, CHILLED
AND CONDENSER
WATER PUMPS

(30 MIN)
10 MINUTES
ELAPSED

COND
FLOW SWITCH
CLOSED

OPERATOR
INITIATE
RESTART

SOLUTION
DILUTION
< 136° F

OPEN
CYCLING
SHUTDOWN
CONTACTS 40/41

② page 66

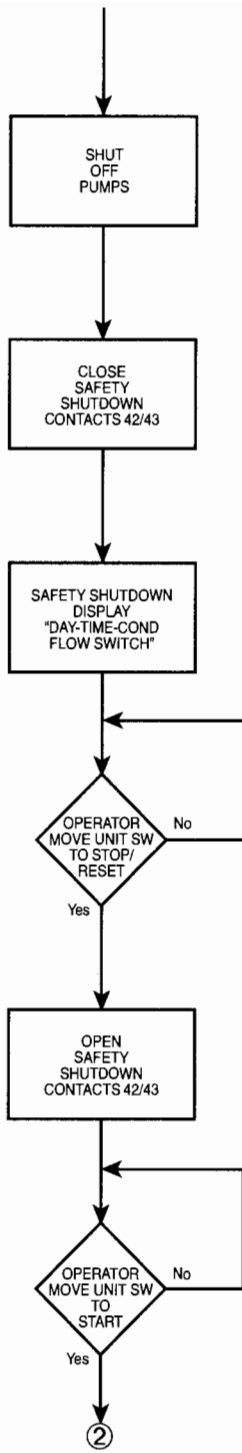

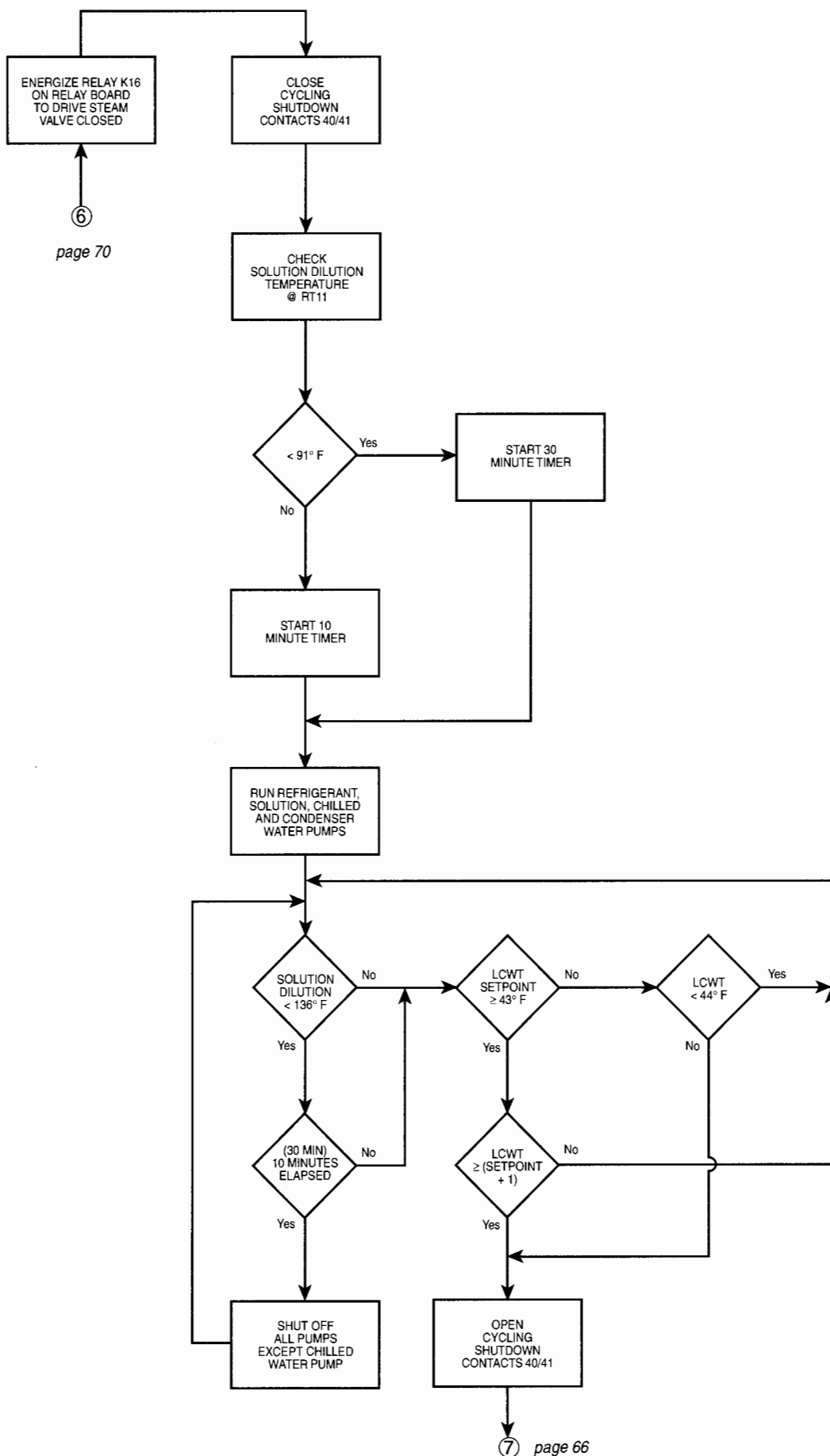

page 70

page 66

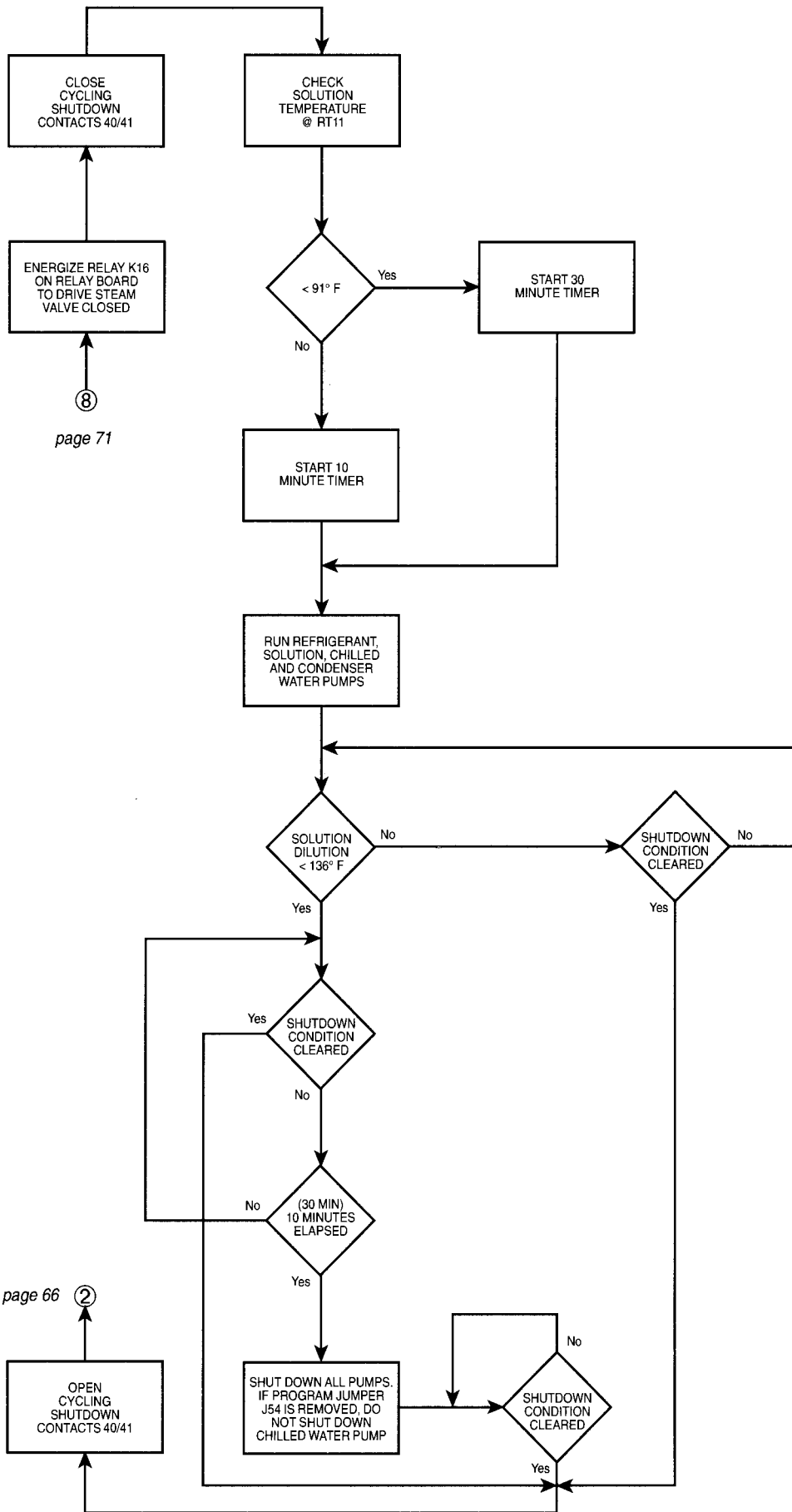

page 71

page 66

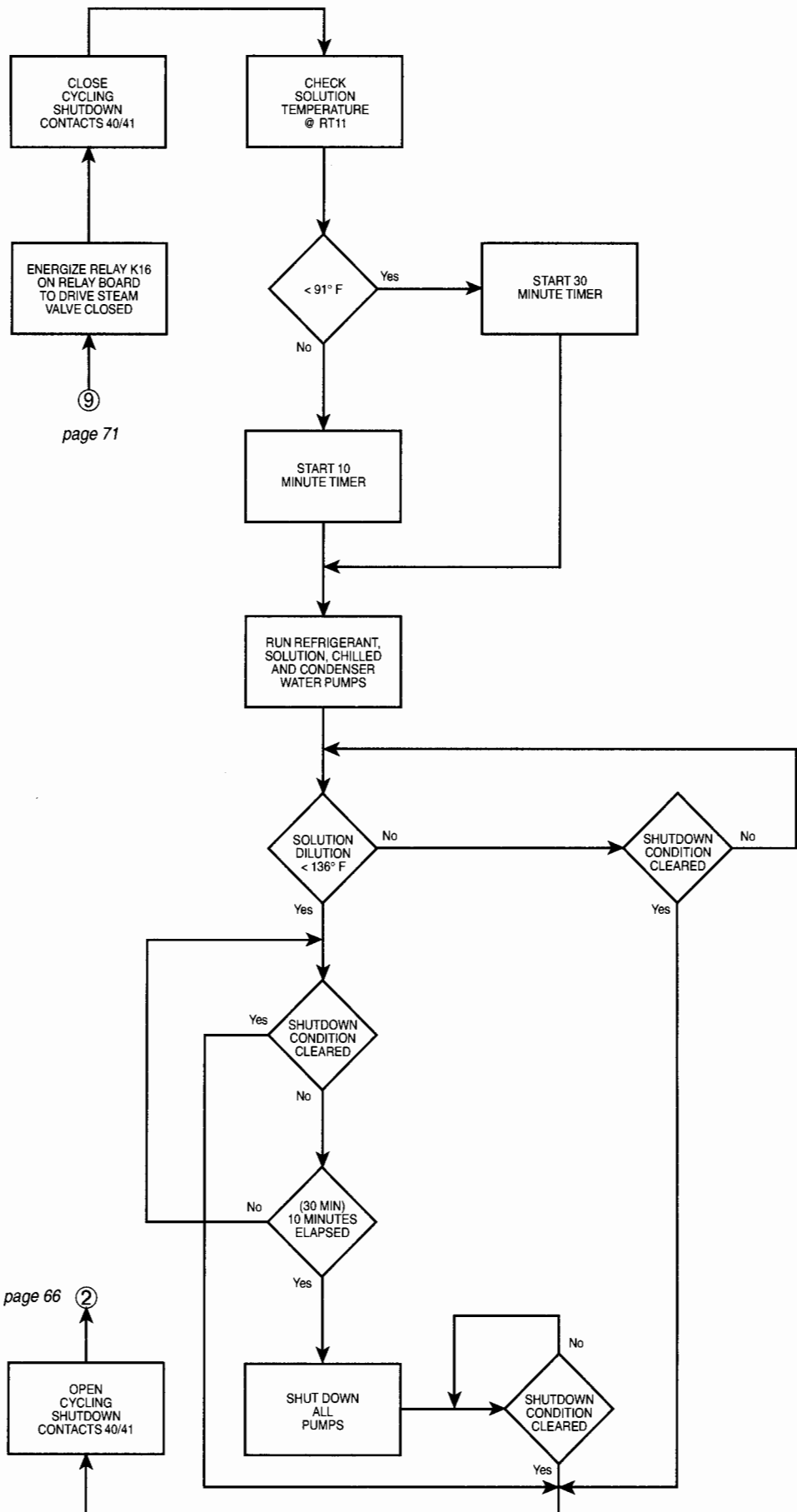

page 71

page 66 2

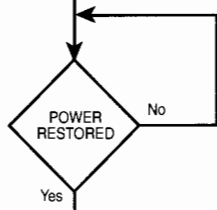

CHECK
STANDBY POWER
SUPPLY STATUS
@ TB2-95

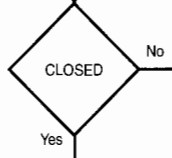

SAFETY SHUTDOWN -
DISPLAY "DAY-TIME-PF-
CHK SOL'N LEVEL - ABS &
GEN" AS STATUS. CLOSE
SAFETY SHUTDOWN
CONTACTS 42/43

POSSIBLE CRYSTALLIZATION!!!
TECHNICIAN MUST CHECK
SOLUTION LEVEL IN ABS &
GENERATOR. RESTART
ALLOWED AFTER PRESSING
WARNING RESET KEY IN
SERVICE MODE WITH UNIT
SWITCH IN STOP/RESET

4
page 66

2
page 66

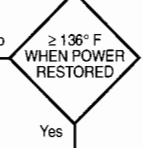
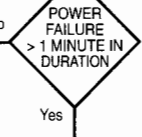

SAFETY SHUTDOWN -
DISPLAY "DAY-TIME-LD-
CHK SOL'N LEVEL - ABS &
GEN" AS STATUS. CLOSE
SAFETY SHUTDOWN
CONTACTS 42/43

POSSIBLE CRYSTALLIZATION!!!
TECHNICIAN MUST CHECK
SOLUTION LEVEL IN ABS &
GENERATOR. RESTART
ALLOWED AFTER PRESSING
WARNING RESET KEY IN
SERVICE MODE WITH UNIT
SWITCH IN STOP/RESET

CYCLING SHUTDOWN -
DISPLAY "DAY-TIME-
POWER FAILURE -
AUTOSTART" AS STATUS.
CLOSE CYCLING SHUT-
DOWN CONTACTS 40/41

START
10 MINUTE
DILUTION CYCLE
TIMER

RUN REFRIGERANT,
SOLUTION, CHILLED
AND CONDENSER
WATER PUMPS

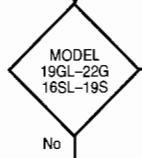

START 2ND SPRAY (G-
SERIES), SPRAY (S-
SERIES) SOLUTION
PUMP AFTER "SPRAY
SOLUTION PUMP DELAY"

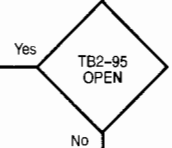

4
page 66

DISPLAY
"DAY-TIME-STANDBY
POWER - UNIT
LOCKOUT" AS STATUS

START
4 HOUR LIMITED
DILUTION CYCLE
TIMER

CYCLING SHUTDOWN -
DISPLAY "DAY-TIME-
SOL'N PUMP ONLY DIL'N
CYCLE" AS STATUS.
CLOSE CYCLING SHUT-
DOWN CONTACTS 40/41

A

B

C

D

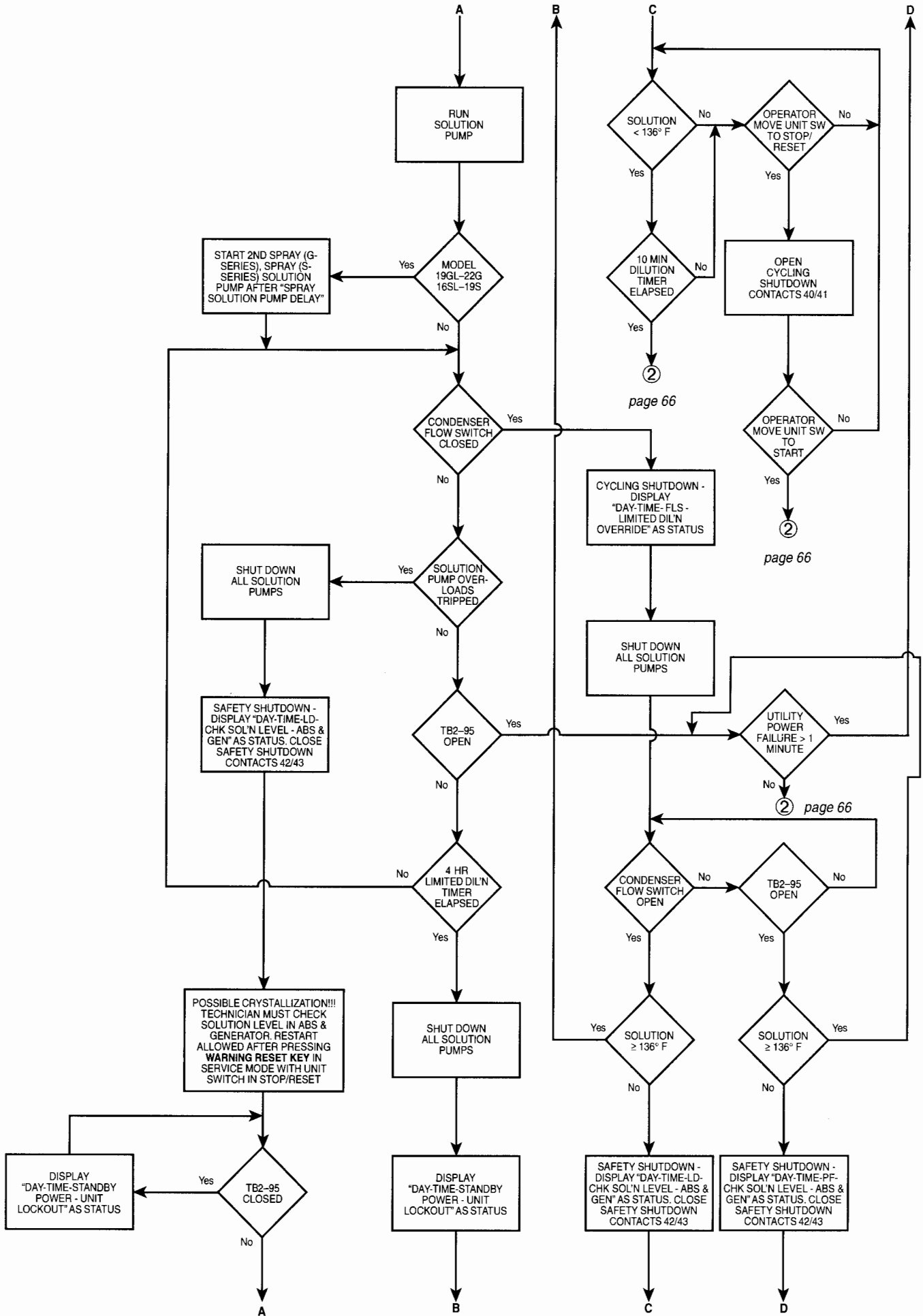

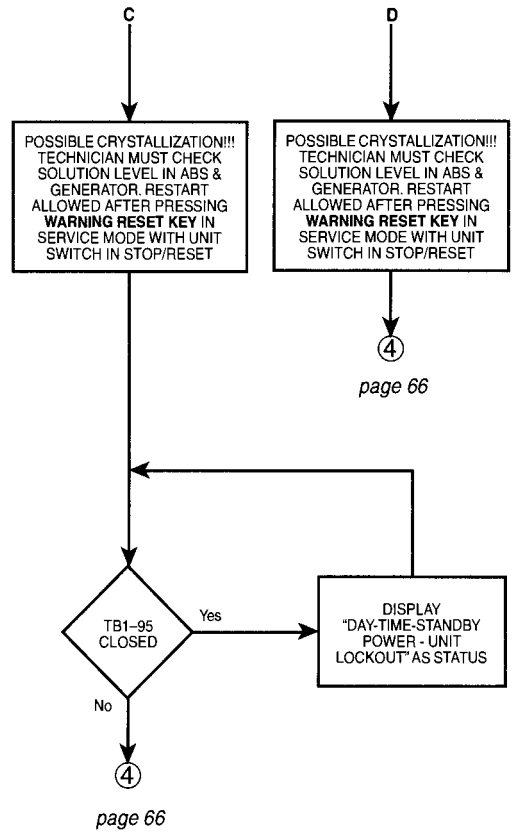
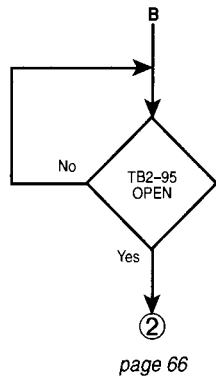
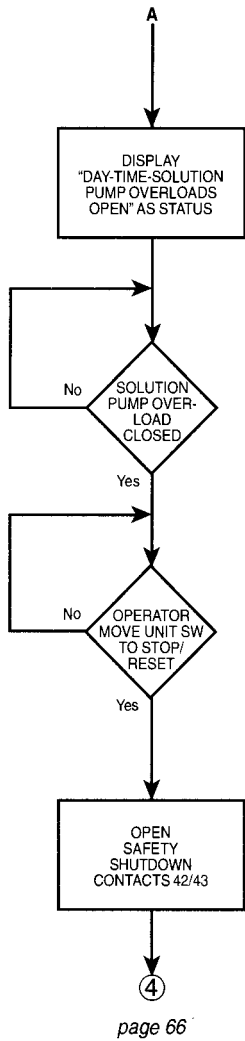

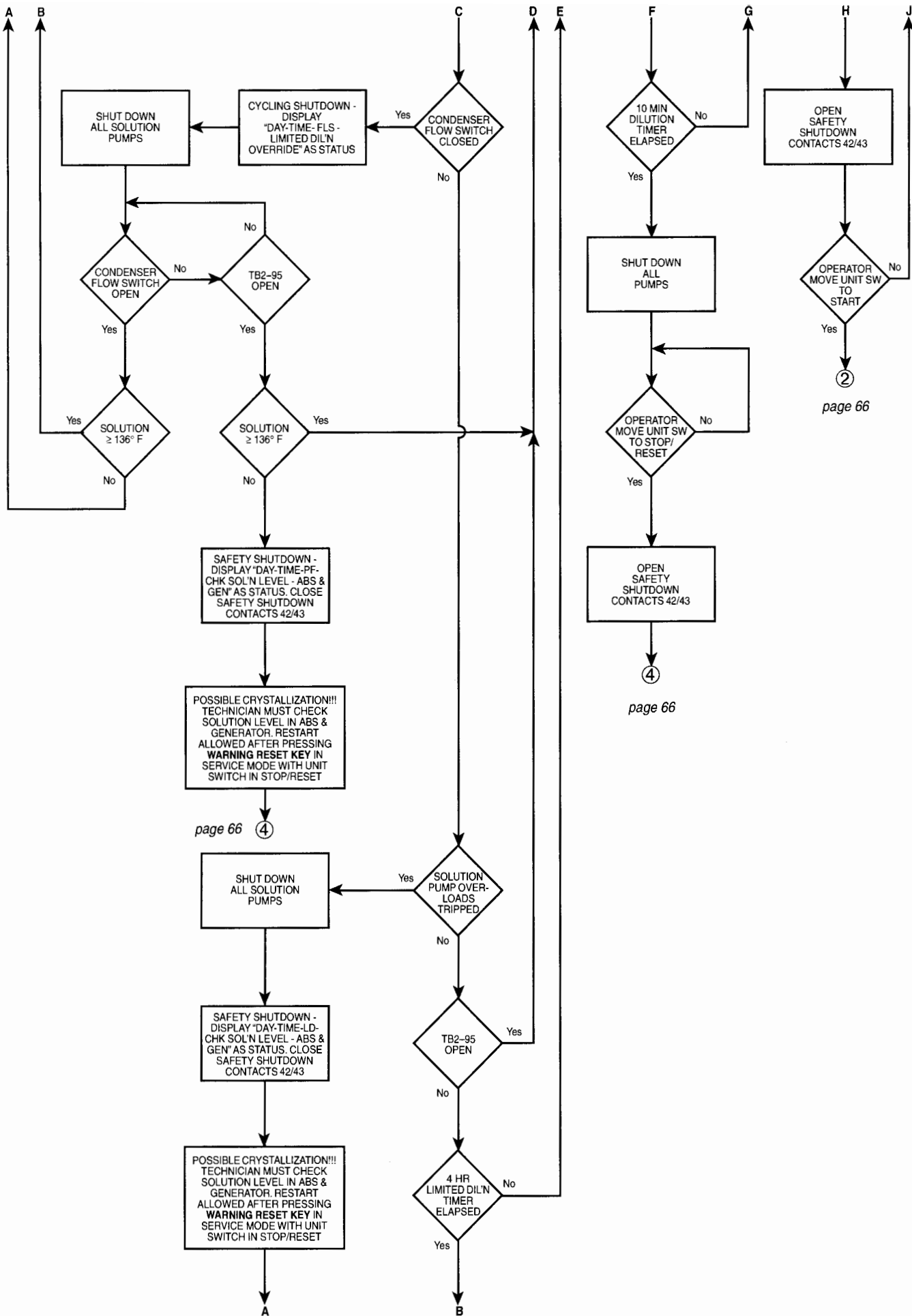

page 66

page 66

page 66 (3)

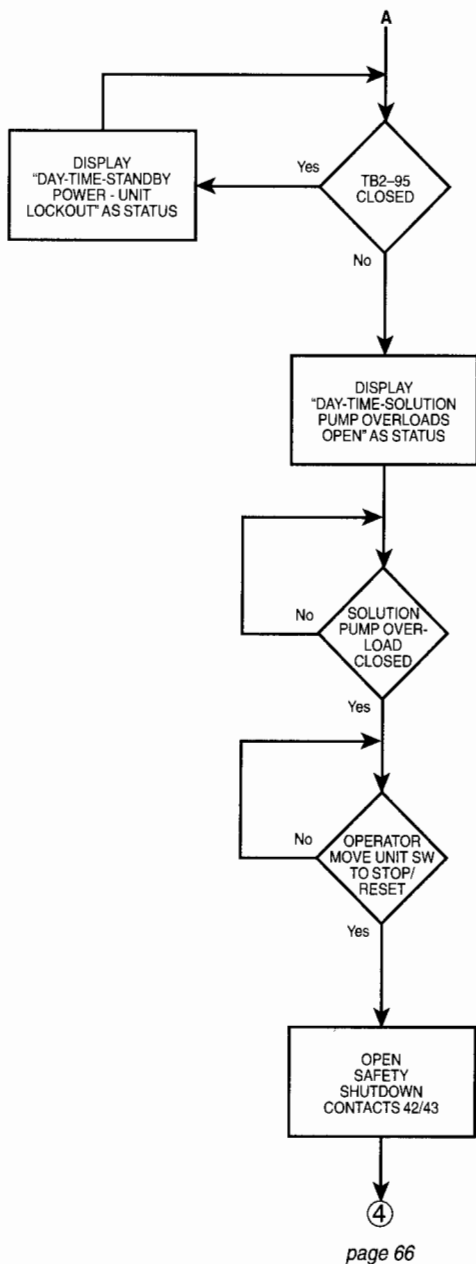

page 66

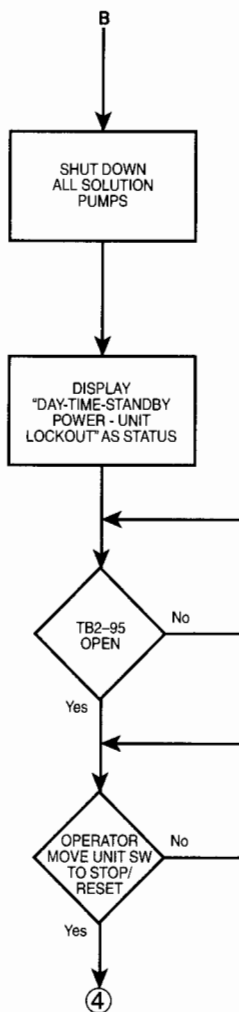

page 66

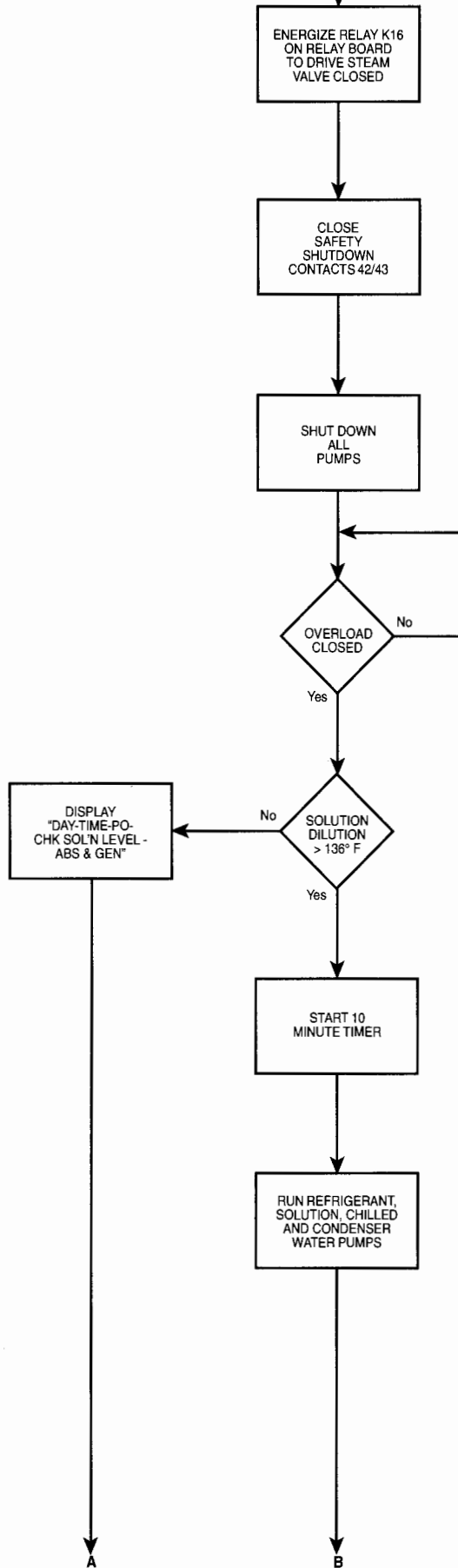

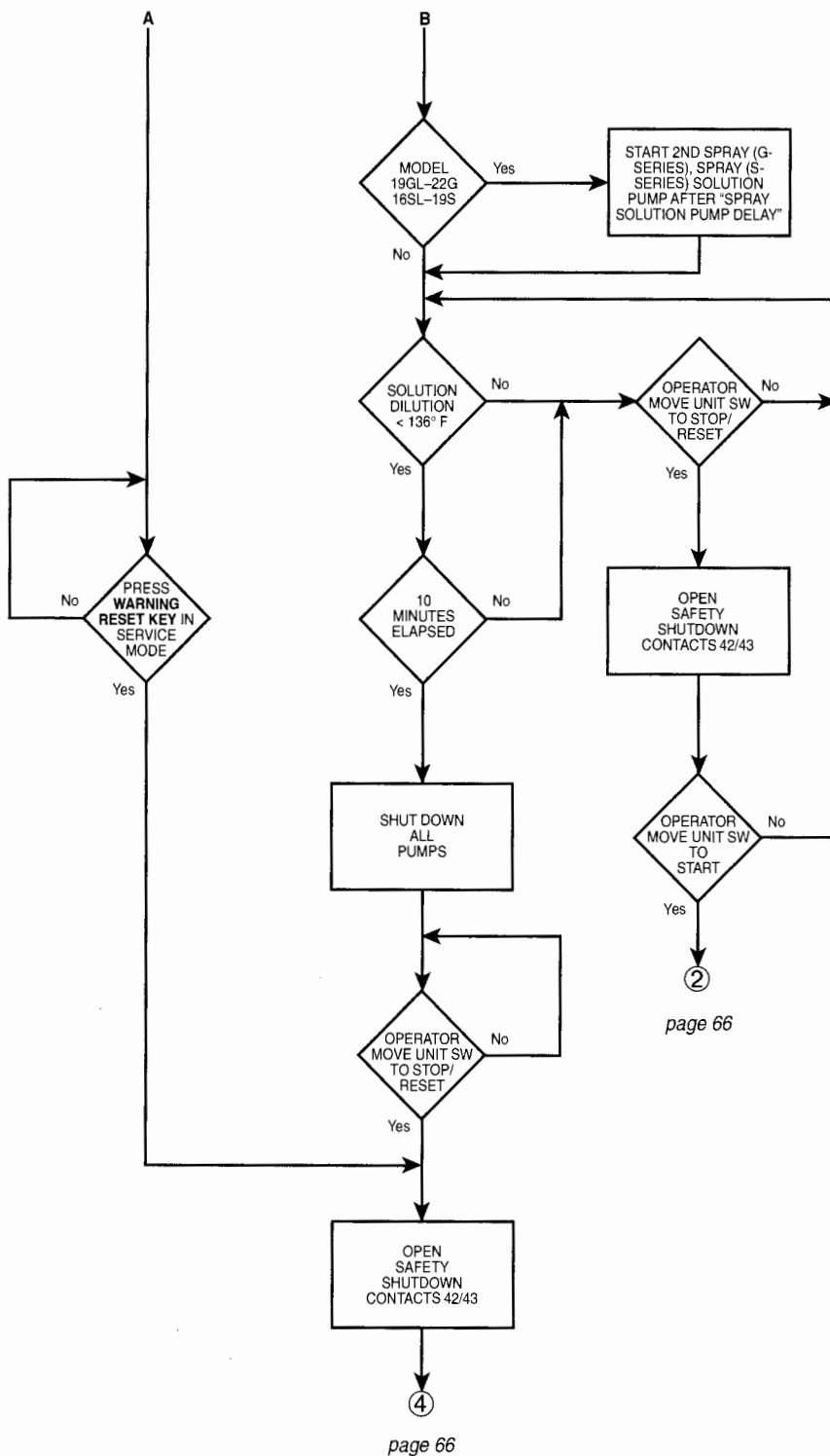

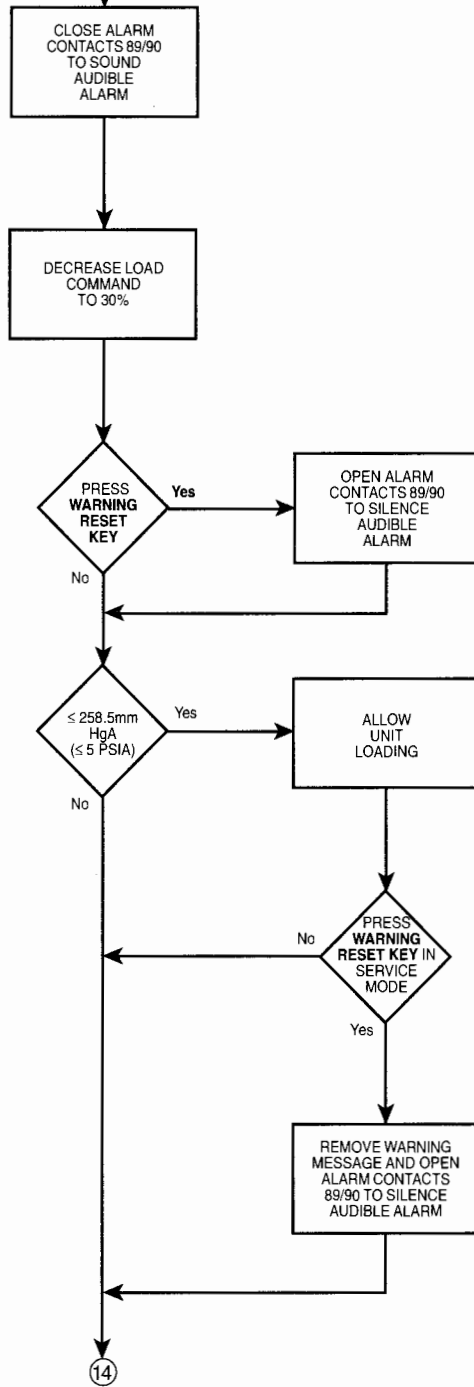

17 page 75

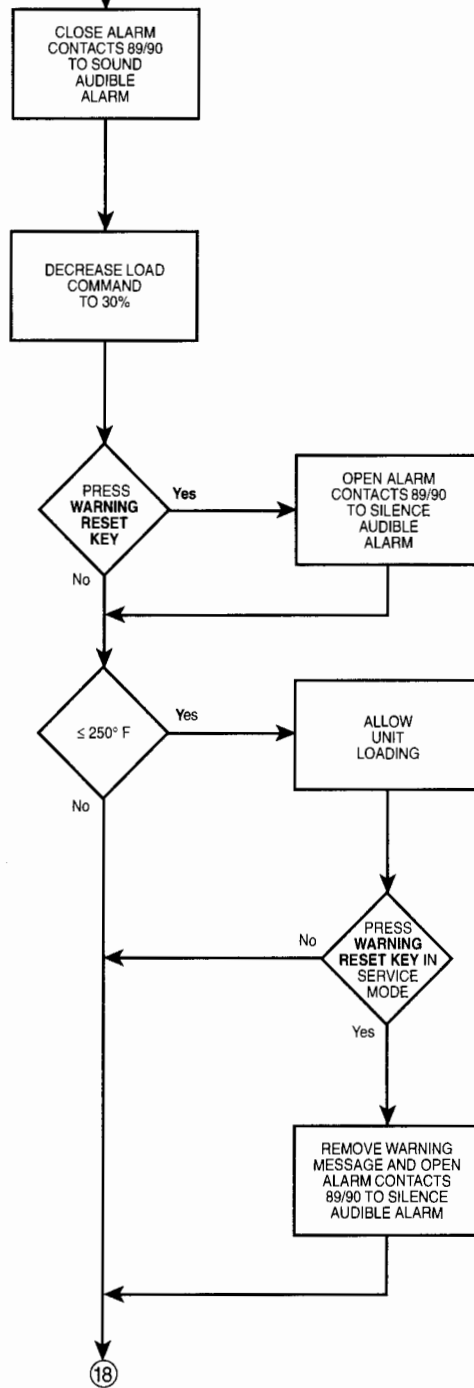

page 75

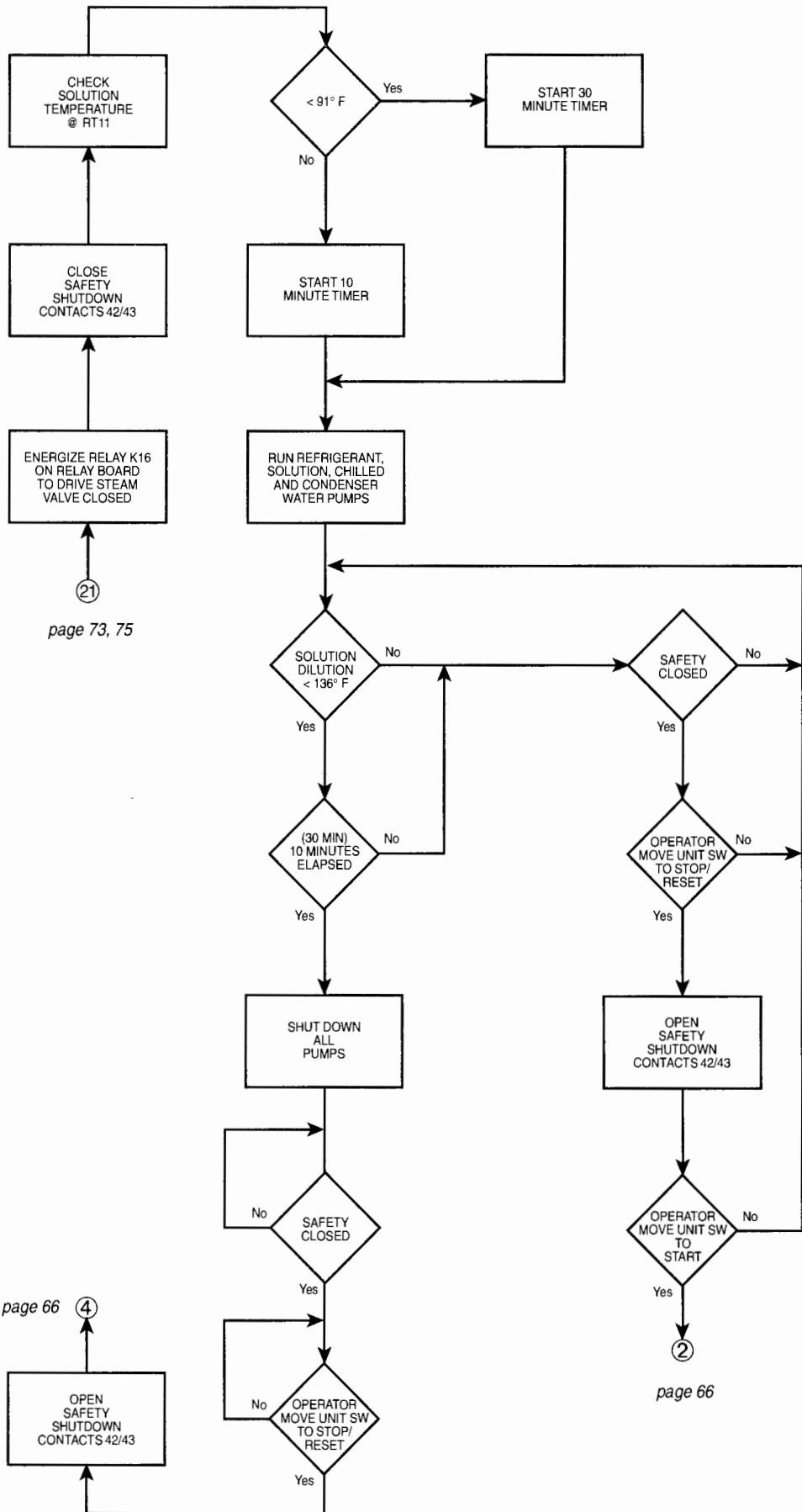

page 73, 75

page 66

page 66

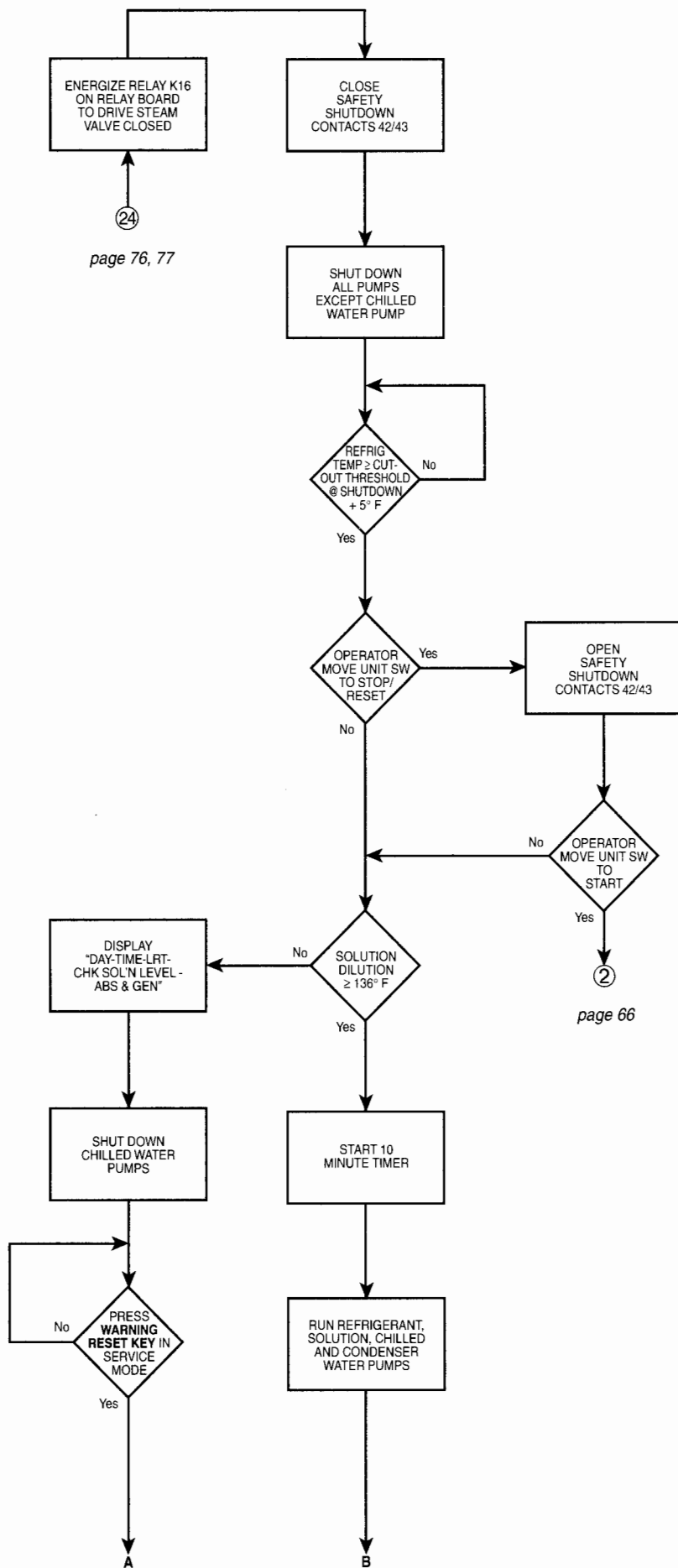

page 76, 77

page 66

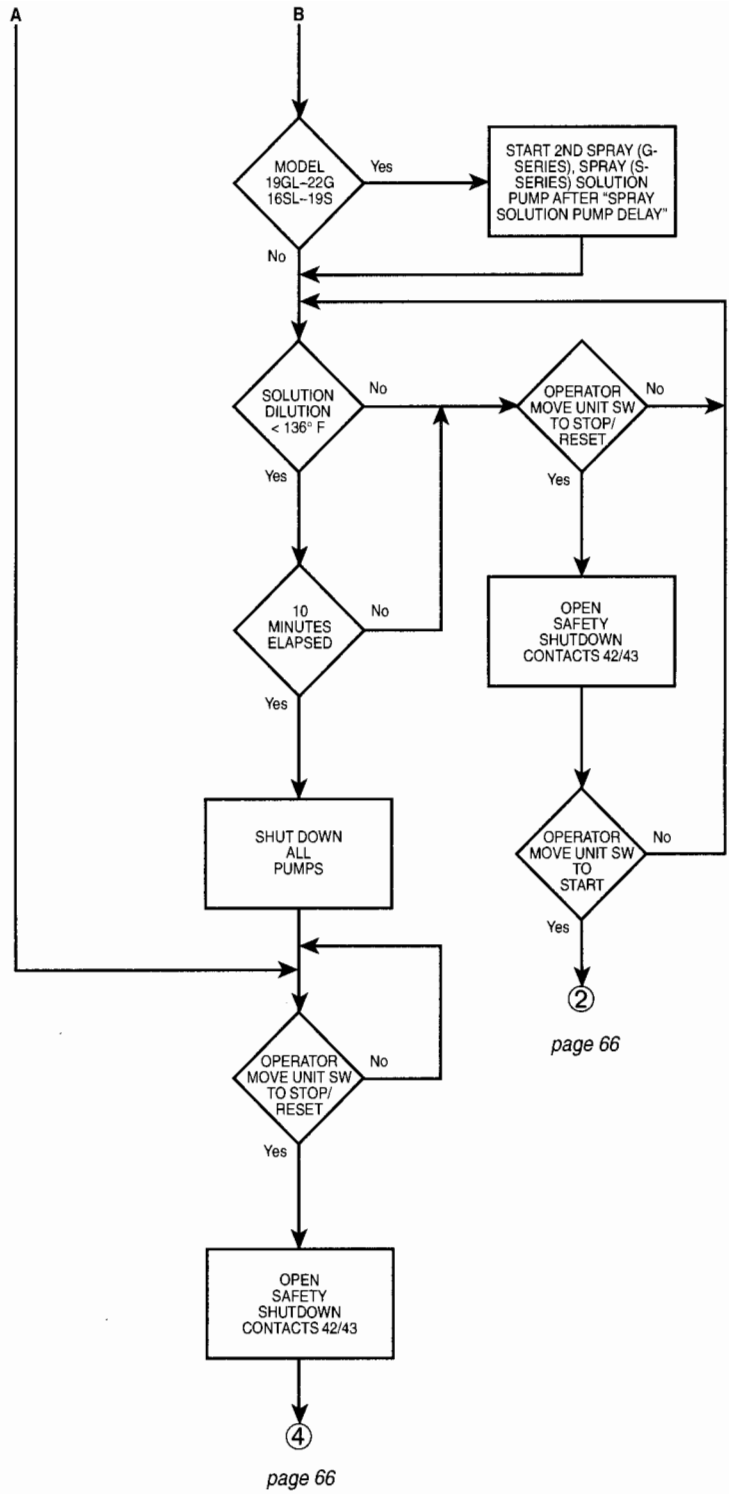

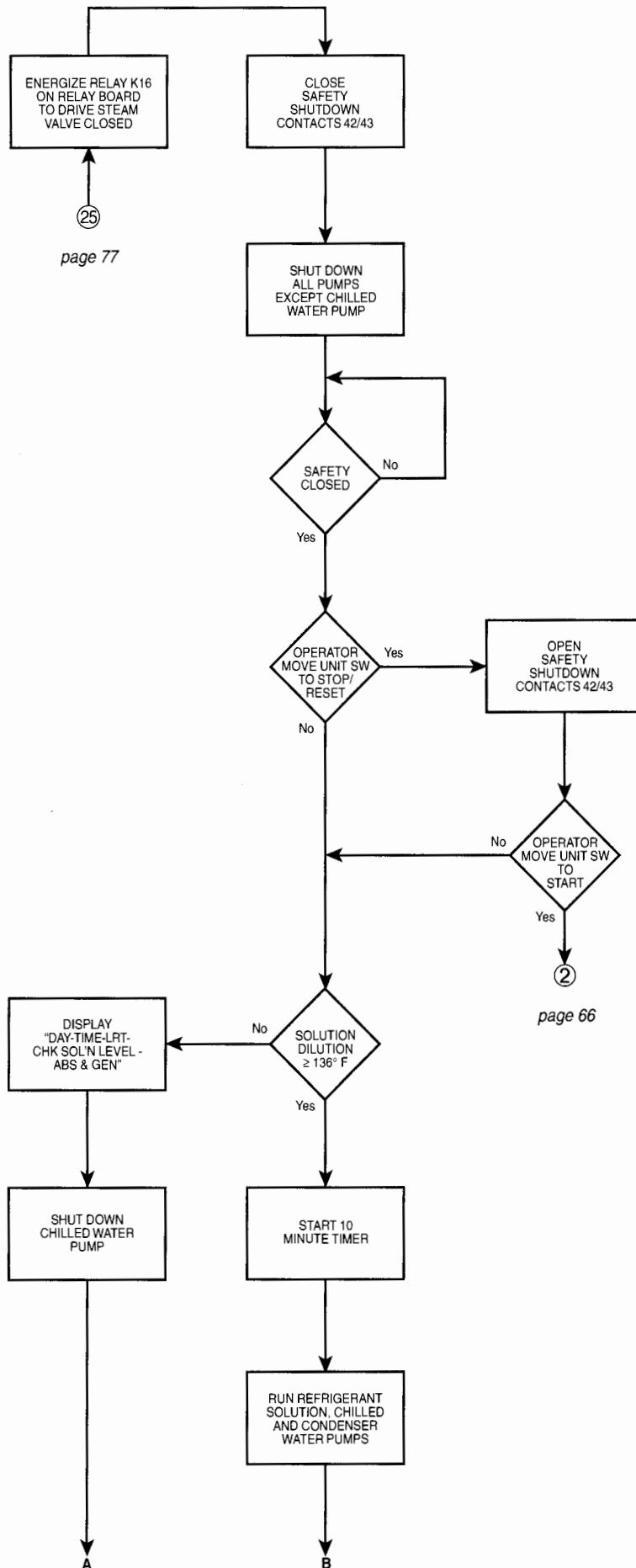

page 77

page 66

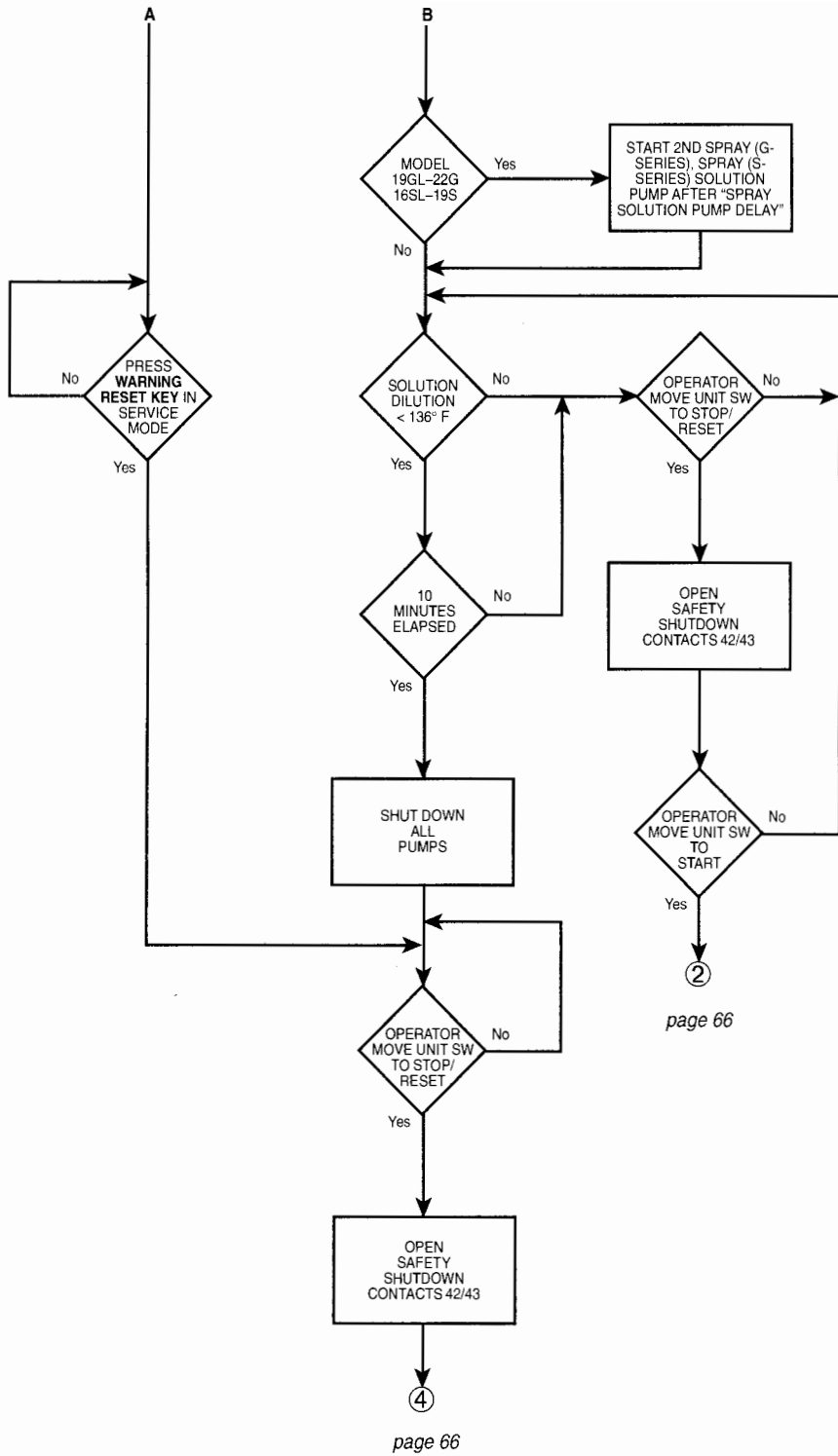

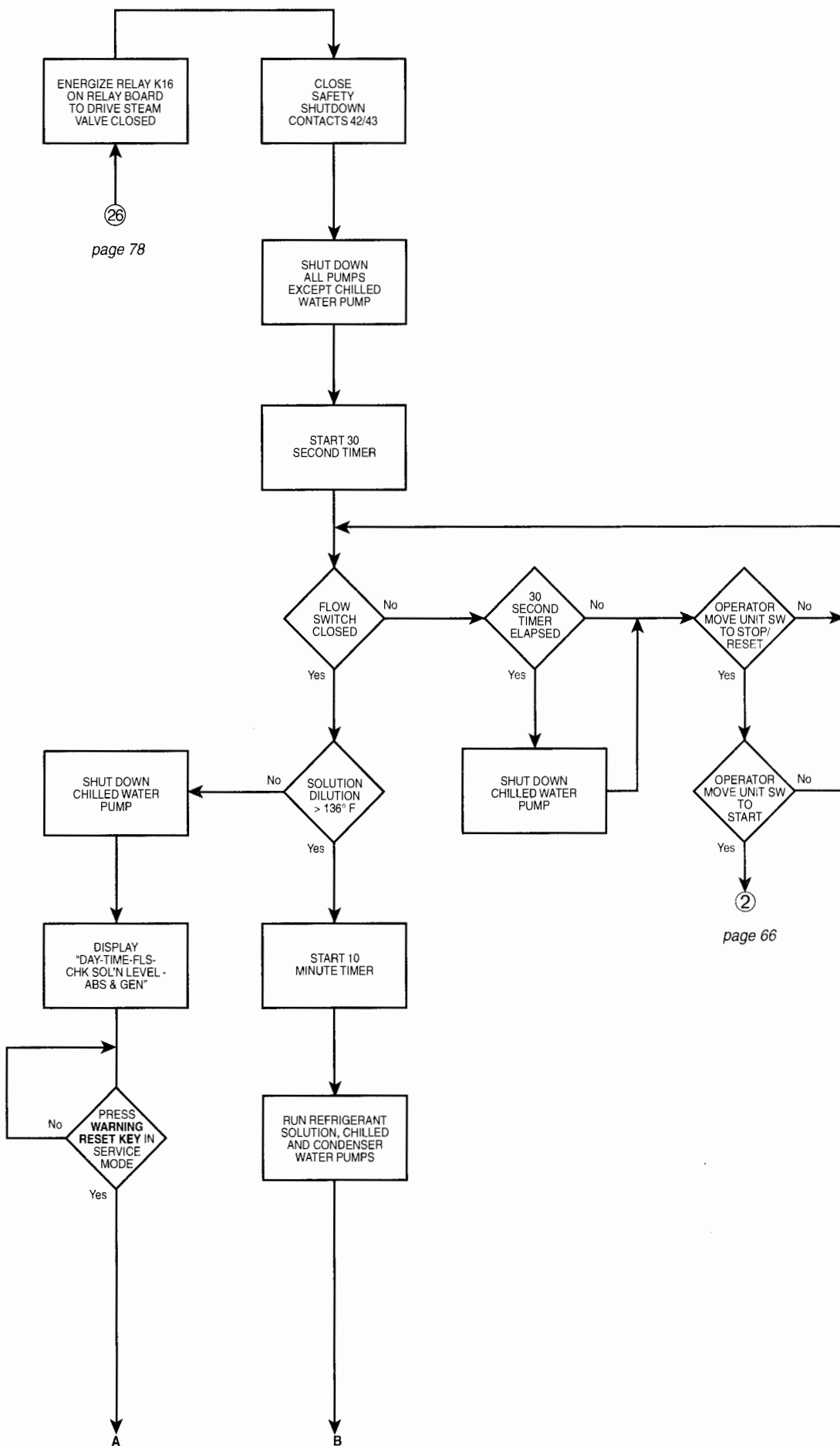

page 78

page 66

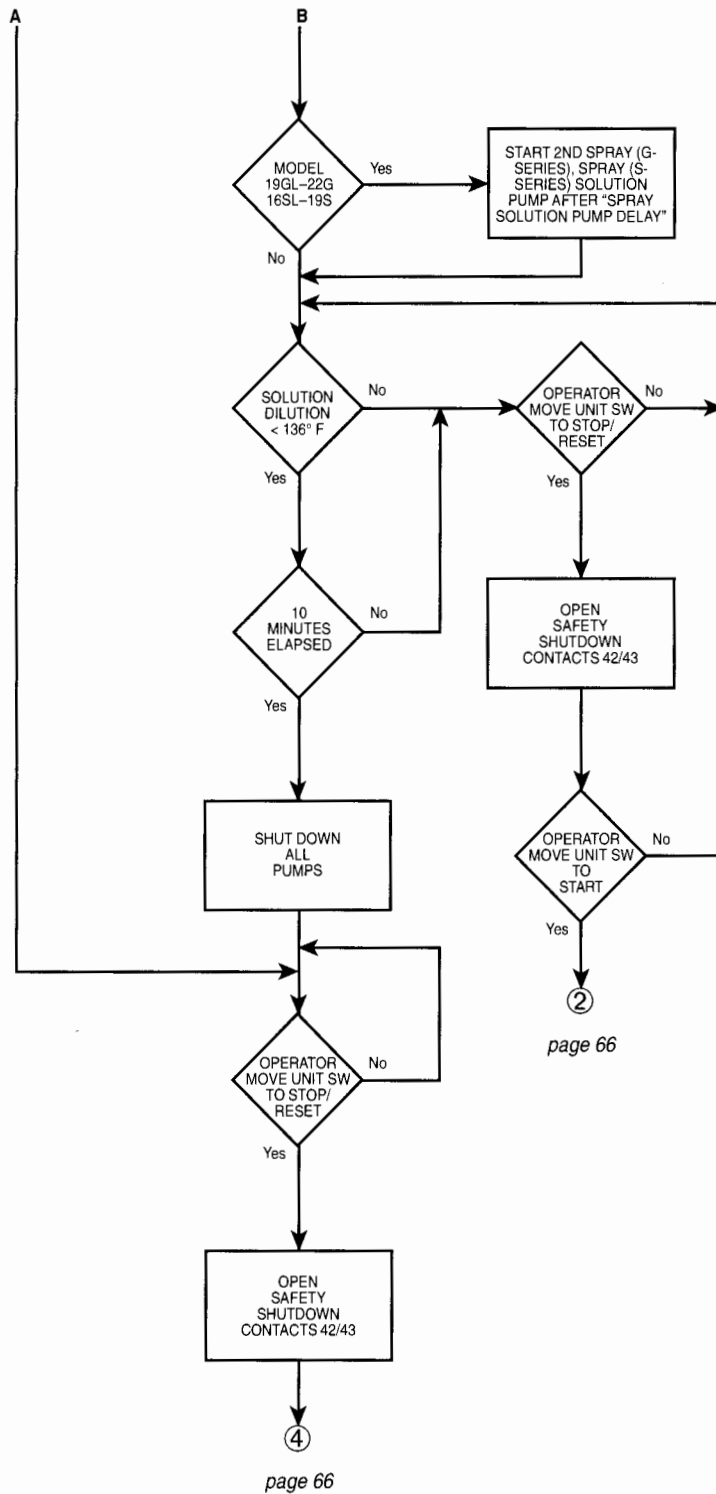

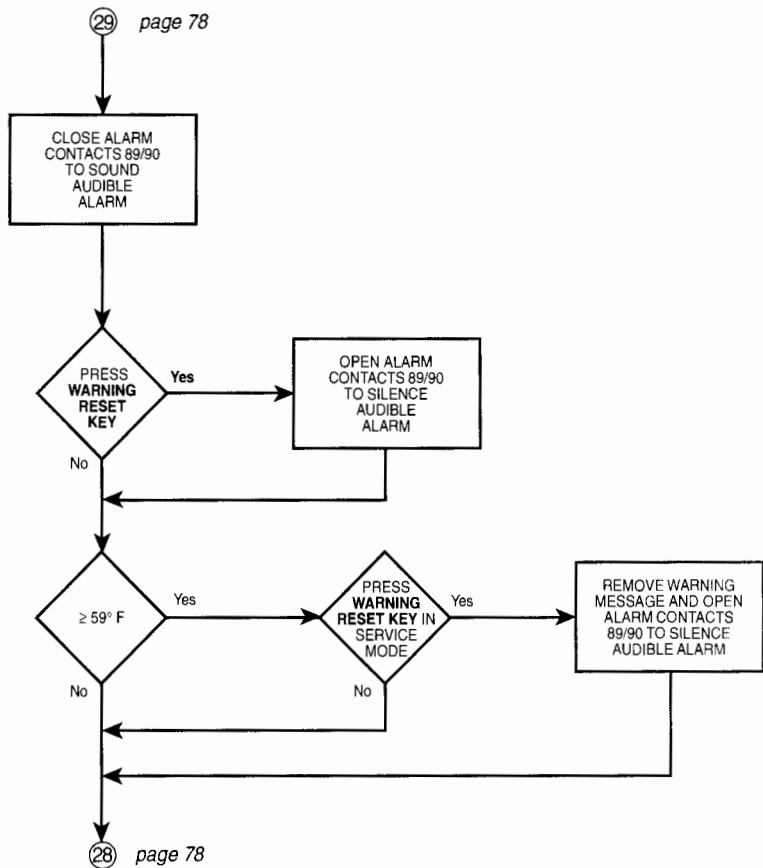
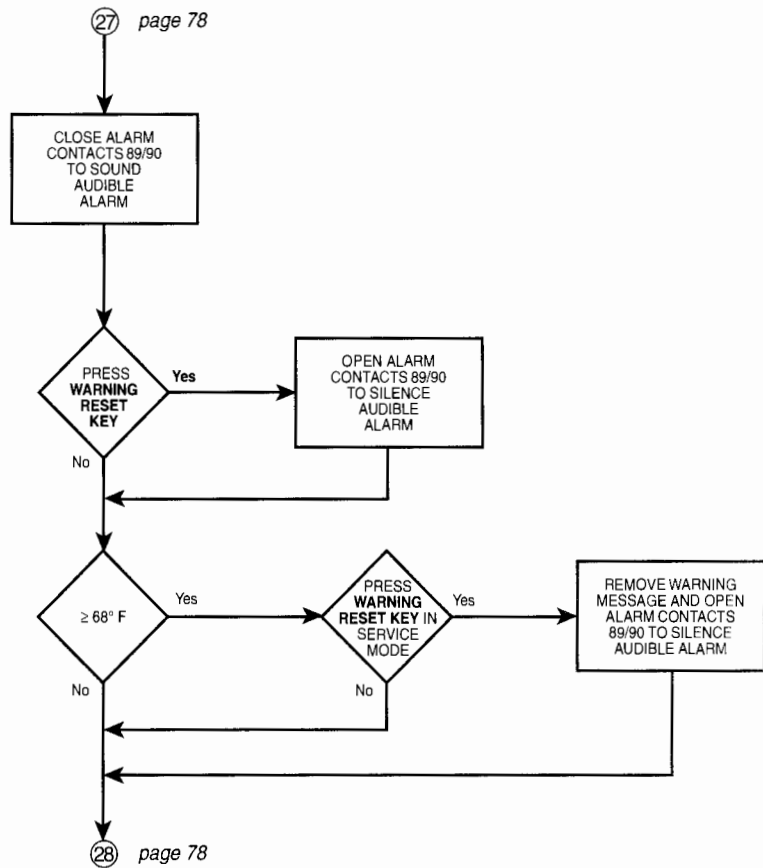

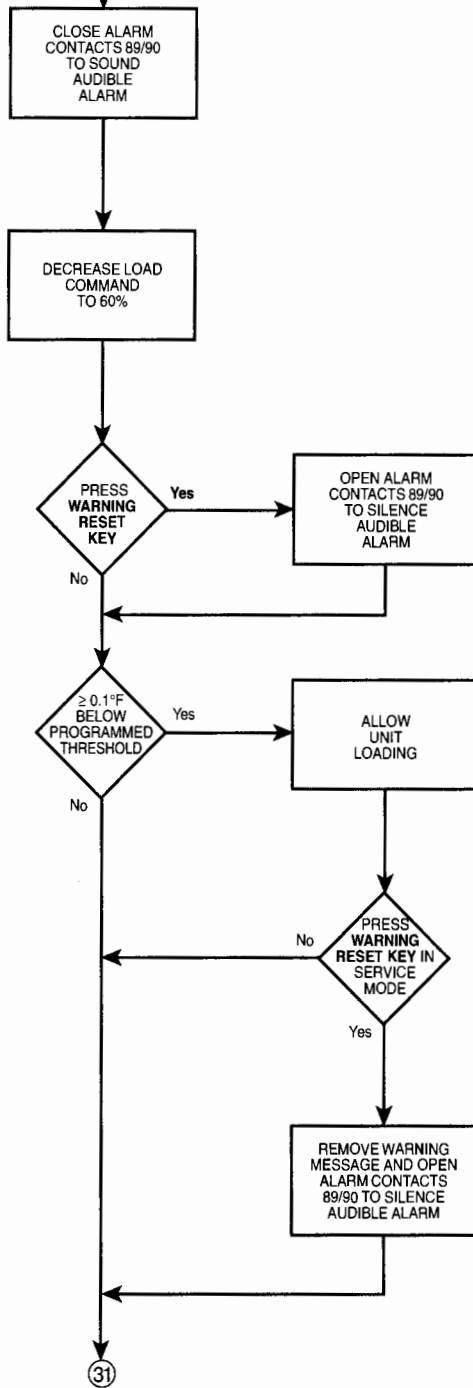

32 page 78

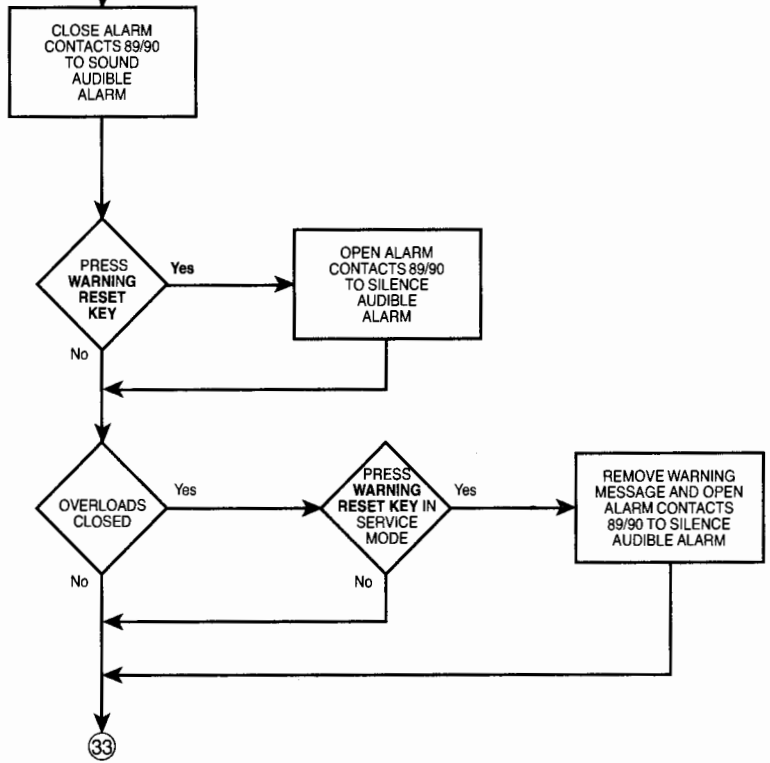

page 78

40 page 83

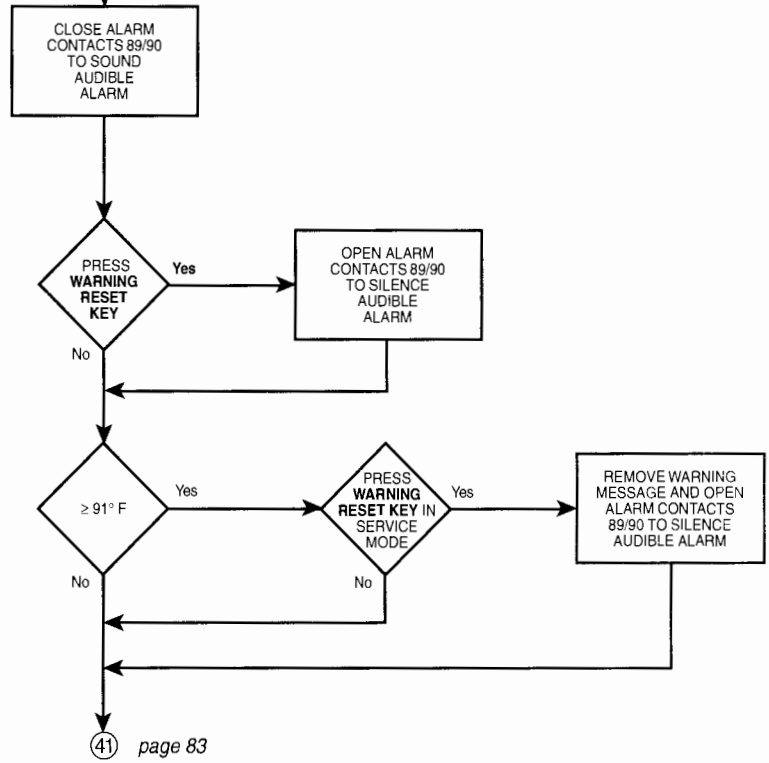

42 page 84

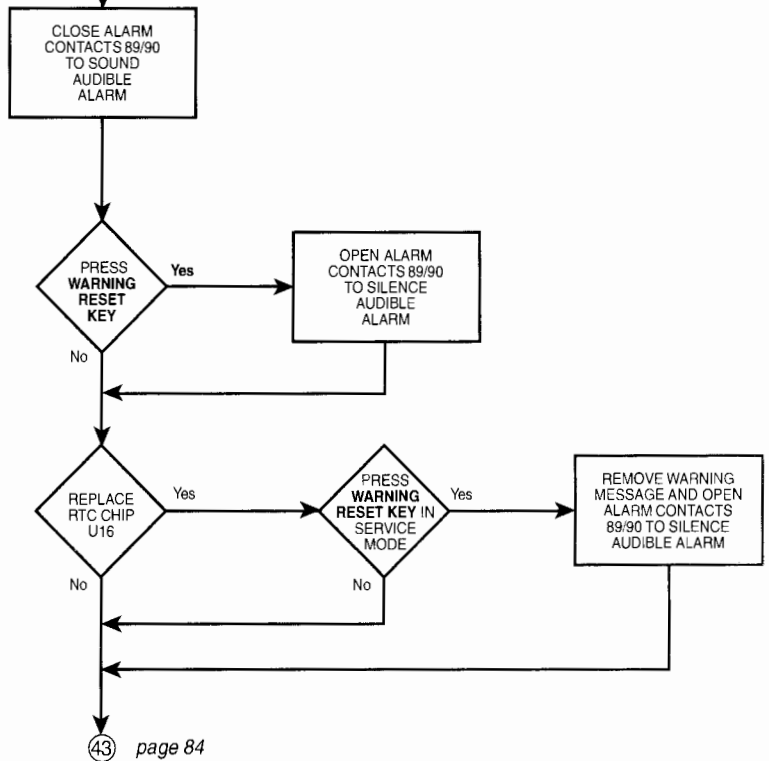

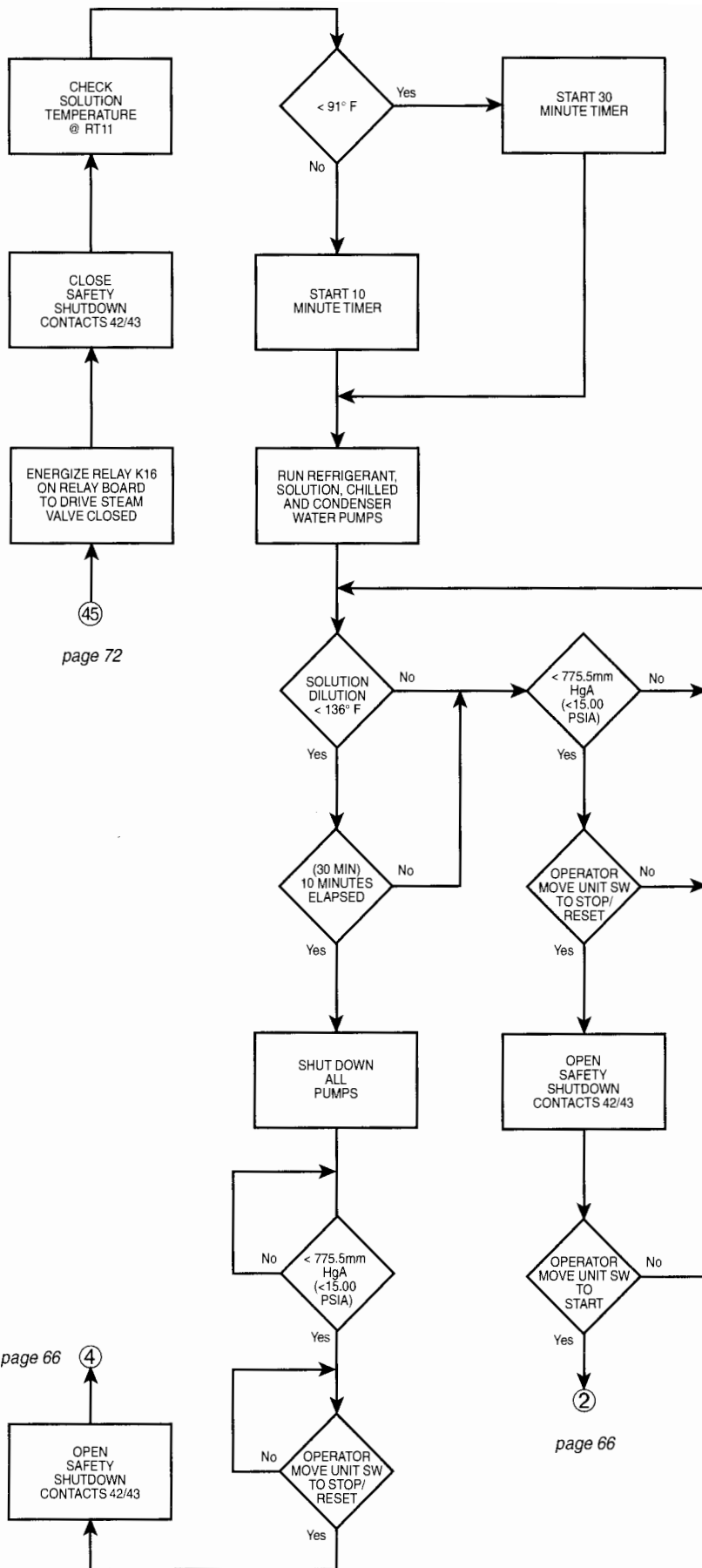

page 72

page 66

page 66

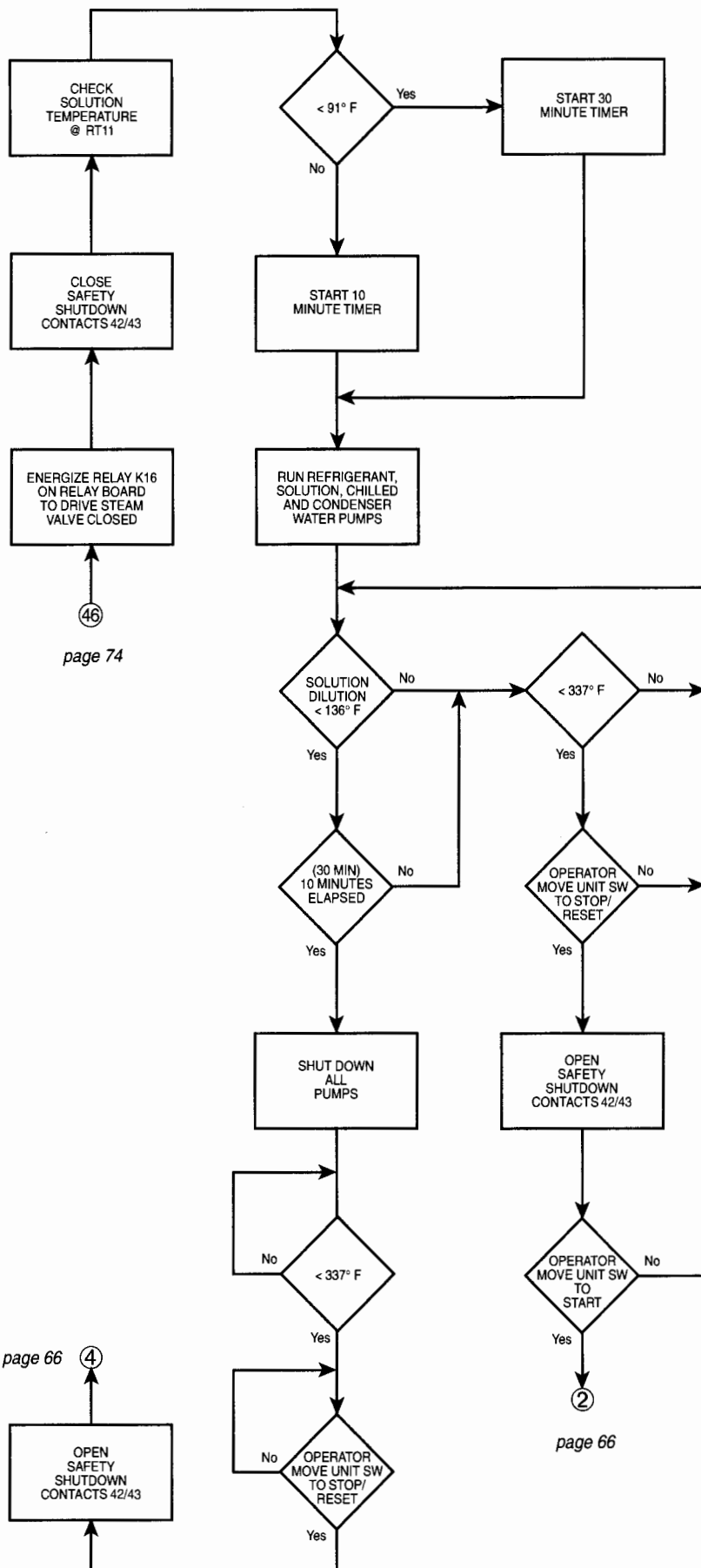

page 66 ④

page 66 ②

CONTROL CENTER

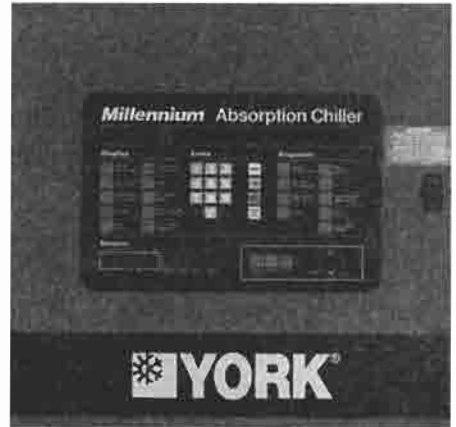

FIG. 1 - MICROCOMPUTER CONTROL CENTER AND KEYPAD

The Control Center front panel layout consists of five key groups, one switch, and a 1-line by 40-character alphanumeric vacuum fluorescent display (see Fig. 1).

CHARACTER DISPLAY - The alphanumeric vacuum fluorescent display is located to the right of the **STATUS** key. All messages, parameters, setpoints, and data can be viewed at this location. The main communications between the operator or service technician and the YPC Control Center occur on this display.

DISPLAY - Provides a direct readout of each monitored parameter on the alphanumeric display.

ENTRY - These keys are used to enter the values for operator programmed setpoints. These keys are used in conjunction with the **SETPOINT** keys while in **PROGRAM** mode.

SETPOINTS - These keys are used as follows:

1. To view each setpoint, in any mode or
2. To select the individual setpoints that are programmed by the operator in **PROGRAM** mode only.

Pressing the appropriate key enables the operator to program that setpoint by pressing the **ENTRY** keys.

ACCESS CODE—This key, along with the **ENTRY** keys, is used to enter the 4-digit access code. Entry of the correct access code allows the operator access to **PROGRAM** mode, where the operator can change **Setpoints** or **OPERATING** modes (**LOCAL**, **REMOTE**, or **SERVICE**). This access code provides security. It prevents tampering by unauthorized personnel.

PROGRAM - Permits the operator to change setpoints and operating modes (**LOCAL**, **REMOTE**, **SERVICE**).

MODE - Permits operator to check what mode the Control Center is presently in. Also, used with the **PROGRAM** key to change operating modes. The modes are:

1. **Local** - Allows manual unit start from the **UNIT** rocker switch on the front panel. Also allows certain cycling inputs from remote devices to start and stop unit.
2. **Remote** - Allows remote start and stop of unit. Also allows remote reset of leaving water temperature (chilled or hot) and remote load limit setpoints.

3. **Service** - Allows manual control of burner or steam valve and pumps. Allows use of the **WARNING RESET** key.
4. **Program** - Allows operator to change modes and program setpoints.

UNIT SWITCH—This 3-position rocker switch is used for **START, RUN, STOP/RESET** functions. This switch cannot be used to start the unit in **REMOTE** mode.

OPERATION

DISPLAYING SYSTEM PARAMETERS

The **DISPLAY** keys are used to display selected monitored parameters as follows (refer to Fig. 1):

- Press and **release** the appropriate **DISPLAY** key. The message will be displayed for 2 seconds.
- or -
- Press and **hold** the appropriate **DISPLAY** key. The message will be displayed and updated every 0.5 seconds until the **DISPLAY** key is released.
- or -
- Press and **release** appropriate **DISPLAY** key, then press and release the **DISPLAY HOLD** key. The message will be displayed and updated every 2 seconds until the **DISPLAY HOLD** key is again pressed and released, or 10 minutes have elapsed, whichever occurs first.
- or -
- For those **DISPLAY** keys that display more than one message, press and hold the **DISPLAY** key. Each message will be displayed for 2 seconds and automatically scroll to the next message as long as the key is pressed. To hold a specific message, press and release the **DISPLAY HOLD** key, then immediately press and release the desired **DISPLAY** key. The first message will be displayed and updated every 2 seconds until the **DISPLAY** key is again pressed and released. Then the second message is displayed. Each time the **DISPLAY** key is pressed and released, the next message is displayed. This can be continued until the **DISPLAY HOLD** key is pressed and released or 10 minutes have elapsed, whichever occurs first. (When pressing the **PUMP STATUS** key in **SERVICE** mode, the **DISPLAY HOLD** feature is automatically engaged. This facilitates manual pump and manual dilution cycle operation.)

NOTE: *X's will not be displayed for parameter values. They are shown below to depict number fields only. If a parameter is out of range, the highest or lowest allowable number is displayed, but the "=" sign is replaced by a greater than ">" or less than "<" sign, whichever is appropriate. Refer to Fig. 2 for the range of each parameter. If the Micro Board program jumper J52 (English/Metric) is installed, all temperatures are displayed in °F and all pressures are displayed in*

mm HgA. If the jumper is removed, all temperatures are displayed in °C and all pressures are displayed in KPa. If I/O expansion board program jumper J12 is installed, all messages displayed in English language. If removed, all messages displayed in German language.

PARAMETER	RANGE
LEAVING CHILLED WATER TEMPERATURE	0.0–81.0°F
RETURN CHILLED WATER TEMPERATURE	0.0–93.0°F
MIXED WATER TEMPERATURE ⁴	8.4–134.0°F
1ST STAGE GENERATOR PRESSURE(S) ¹	0.00–775.7mm HgA
1ST STAGE GENERATOR TEMP(S) ¹	120.0–350.0°F
REFRIGERANT TEMPERATURE	0.0–134.0°F
SOLUTION TEMPERATURE	91.0–346.0°F
LEAVING CONDENSER WATER TEMP	8.4–134.0°F
RETURN CONDENSER WATER TEMP	8.4–134.0°F
LEAVING HOT WATER TEMPERATURE ²	90.0–210.0°F
RETURN HOT WATER TEMPERATURE ²	90.0–210.0°F
2ND STAGE GEN LVG REFRIG TEMP	77.0–210.0°F
PURGE TANK PRESSURE ³	0.00–219.8mm HgA
PURGE PUMP PRESSURE ³	0.00–219.8mm HgA

¹ Models 20G through 22G gas-fired units use 2 each first stage generators. Both have same range.

² Gas-fired units only. Steam-fed units are used on cooling applications only; no hot water is produced.

³ Customer options—supplied as part of automatic purge system.

⁴ Customer option.

FIG. 2 - SYSTEM PARAMETER RANGES

To Display **CHILLED WATER TEMPERATURES:**

Use the **CHILLED WATER TEMPS** display key as described above to produce the following display message:

CHILLED LEAVING = XXX.X 0° F, RETURN = XXX.X ° F

To Display **FIRST STAGE GENERATOR PRESSURE, TEMPERATURE AND SOLUTION CONCENTRATION:**

Use the **1st STAGE GEN PRESS/TEMP** key as described above to produce the following messages:

GEN PRESS = XX.XXMM HGA; TEMP = XXX.X° F

HI TEMP GENERATOR CONCENTRATION = XX.X% *

Models 20G through 22G gas-fired units have two first stage generators. When Micro Board program jumper JP1 is IN (gas-fired) and JP4 is OUT (Models 20G through 22G), the Control Center is configured for these gas-fired models and the following is displayed:

GEN 1 PRESS = XX.XXMM HGA; TEMP = XXX.X° F

GEN 2 PRESS = XX.XXMM HGA; TEMP = XXX.X° F

HI TEMP GENERATOR CONCENTRATION = XX.X% *

* This message applies only to units equipped with EPROM version A.01F.09 or later. The message will only be displayed if the unit is running, the first stage generator temperature is at least 250.0° F, and the concentration message display has been enabled by a qualified service technician using "Special Setpoints and Programming Procedures" section of service manual 155.17-M2. This message will not be displayed in **HEATING ONLY** mode.

To Display **REFRIGERANT AND SOLUTION TEMPERATURES:**

Use the **REFRIGERANT/SOL'N TEMPS** key as described above to produce the following message:

REFRIGERANT = XX.X° F; SOLUTION = XXX.X° F

To Display **OPTIONS:**

Use the **OPTIONS** key as described above to display the following message. Presently there are no options programmed.

NO OPTIONS INSTALLED

To Display on/off **STATUS OF SYSTEM PUMPS:**

Use the **PUMP STATUS** key as described above to produce the following messages:

PURGE PUMP - OFF

REFRIGERANT PUMP - ON

SOLUTION PUMP - ON

CHILLED WATER PUMP - ON

CONDENSER WATER PUMP - ON

HOT WATER PUMP - OFF **

SECOND SPRAY SOLUTION PUMP - ON *

MANUAL DILUTION CYCLE - OFF

** Gas/oil units only

* Models 19G through 22G (micro board program jumper JP3 is OUT) have 1 solution pump and 2 spray solution pumps. The first spray solution pump is on anytime the solution pump is on because they are wired in parallel. The second spray solution pump comes on automatically (except when controlled manually) after the first solution pump has started and the setpoint delay has elapsed. "S" series models 16SL through 19S have a single solution pump and a solution spray pump that is started after the setpoint delay has elapsed. The delay is set by the **Spray Sol'n Pump Delay** setpoint. Refer to the "System Setpoints" section for details of this setpoint. This delay value can be viewed at any time by pressing the **SPRAY SOL'N PUMP DELAY** key. This delay must never be arbitrarily changed. The factory-set value must be recorded if the RTC or micro board is to be replaced, so that the same value may be re-entered.

The **PUMP STATUS** key is also used in conjunction with the **MANUAL PUMP** key in **SERVICE** mode to manually turn the pumps on and off. Refer to the "Service Keys" section for details.

To Display **CONDENSER WATER TEMPERATURES:**

Use the **CONDENSER WATER TEMPS** key as described above to produce the following message:

COND LEAVING = XXX.X° F; RETURN = XXX.X° F

To Initiate a **PRINT** to the Printer:

Press the **PRINT** key to initiate a printout to the optional printer. Refer to Instruction Form 155.17-NO1.2 for details of optional printers. Pressing this key produces the following message:

PRINT ENABLED

If the Control Center is in the process of transmitting data to a printer and the **PRINT** key is pressed, the following is displayed:

PRINT REQUEST IN PROGRESS . . .

To Display **HOT WATER TEMPERATURES**:

Use the **HOT WATER TEMPS** display key as described above to produce the following message:

Gas/Oil-Fired Units

If the unit is operating in **COOLING ONLY** mode, the display is blanked. In **HEATING ONLY** or **HEATING AND COOLING MODE**, the following is displayed:

HOT LEAVING = XXX.X° F; RETURN = XXX.X° F

Steam-Fed Units

The display is blanked. Steam-fed units are not used on heating applications. Therefore, no hot water is produced.

To Display **OPERATING HOURS** and **STARTS COUNT**:

Use the **OPERATING HRS/START COUNTER** display key as described above to produce this message:

OPER HOURS = XXXXX; START COUNTER = XXXXX

NOTE: When the micro board or Real Time Clock (RTC) chip (IC U16 on micro board) is replaced, these values will be lost. Prior to removing the defective component, the service technician should log these values. After the new component is installed, these values should be entered using the "Special Programming Procedure" in the service manual, Form 155.17-M2. These values can also be reset to zero using the "Special Programming Procedures."

To Display the **NUMBER OF PURGE CYCLES** that have occurred over the last 7 days and over the lifetime of the unit:

Use the **PURGE CYCLE COUNTER** display key as described above. The following messages will scroll on the display:

LAST 7 DAYS = XXX; TOTAL MAN PURGES = XXXXX

▲
Total manual purges
in the last 7 days

▲
Total manual purges to date
over lifetime of unit

LAST 7 DAYS = XXX; TOTAL AUTO PURGES = XXXXX *

▲
Total auto tank purges
in the last 7 days

▲
Total auto tank purges to date
over lifetime of unit

* Only displayed if unit equipped with EPROM version A.01F.09 (or later) and equipped with the Automatic Purge Hardware (I/O expansion board program jumper JP1 removed).

SYSTEM SETPOINTS

The system setpoints may be programmed by the system operator. The **SETPOINTS** keys are located on the Control Center keypad (see Fig. 1). To program, see "Programming System Setpoints." The following is a description of these setpoints.

Leaving Water Temp - This setpoint determines the leaving water temperature that the unit will maintain. In **COOLING** mode or **COOLING AND HEATING** mode, it is the temperature of the water that is leaving the evaporator. It is called **Leaving Chilled Water** setpoint. Its range is 42°F to 77°F. The default value is 44°F. In **HEATING** mode, it is the temperature of the water leaving the hot water heat exchanger. It is called **Leaving Hot Water** setpoint. For "G" series units, there are two ranges available:

- If micro board program number JP5 is installed, the range is 90°F to 150°F for the standard heat exchanger.
- If JP5 is removed, the range is 90°F to 175°F for the optional high temp heat exchanger.

Standard "S" series units do not have an external hot water heat exchanger and the range is 90°F to 140°F. "S" series units equipped with the high temperature option and having JP5 removed have a range of 90°F to 175°F. The default value for heating mode is 140°F.

An Energy Management System (EMS) can be connected to the Control Center to change the leaving water temperature setpoint from a remote location while the Control Center is operating in **REMOTE** mode. Refer to field control modifications diagram Form 155.17-PA1 for details of remote setpoint reset operation.

Cool/Heat Changeover - This setpoint selects **COOLING ONLY**, **HEATING ONLY** or **COOLING AND HEATING** mode.

"G" series gas/oil-fired units can operate in **COOLING ONLY**, **HEATING ONLY** or **COOLING AND HEATING** mode.

"S" series standard gas/oil-fired units are not equipped with a separate heat exchanger. They use the evaporator to heat water. Therefore, these units can only operate in **COOLING ONLY** or **HEATING ONLY** mode. They cannot operate in **COOLING AND HEATING** mode. When operating in **HEATING ONLY** mode, micro board program jumper JP2 must be removed. This causes the refrigerant, solution, spray solution and chilled water pump to run during heating mode.

Gas/oil-fired "S" series units equipped with the high temperature option have a separate heat exchanger. These units can operate in the same modes as the "G" series.

Steam-fed units can operate only in **COOLING ONLY** mode. No changeover is allowed.

In **COOLING ONLY** mode, the unit operates to control the temperature of the leaving chilled water to the desired **Leaving Chilled Water** setpoint.

In **HEATING ONLY** mode, the unit operates to control the temperature of the leaving hot water to the desired **Leaving Hot Water** setpoint.

In **COOLING AND HEATING** mode, the unit operates to control the temperature of the leaving chilled water to the desired **Leaving Chilled Water** setpoint while a customer-supplied device controls a 3-way mixed water valve to maintain the desired hot water temperature.

This setpoint can be changed only when the **UNIT** switch is in the **STOP/RESET** position and no dilution cycle is in progress. There are system valves that must be adjusted when making the changeover. Refer to YORK Form 155.17-NM1 for details of changeover.

Spray Sol'n Pump Delay - With micro board program jumper JP3 OUT, the Control Center is configured for "G" series models 19GL through 22G and "S" series models 16SL through 19S.

The "G" series models have a solution pump, a first spray solution pump and a delayed-on second spray solution pump. The first spray solution pump is turned on coincident with the solution pump. The second spray solution pump should not be started until the first spray solution pump has pumped solution to the second spray solution pump. The delay between the start of the first spray solution pump and the second spray solution pump is the **Spray Sol'n Pump Delay**. It is programmable from 30 to 120 seconds (10 to 120 seconds with EPROM version A.01F.09 or later), with 90 being both the nominal delay and the default value.

The "S" series models have a solution pump and a delayed-on spray solution pump. The spray solution pump is started 30 to 120 seconds (10 to 120 seconds with EPROM version A.01F.09 or later; as programmed with the **Spray Sol'n Pump Delay** setpoint) after the solution pump. This delay is required as explained above.

This factory setpoint is established and entered into the Control Center at the YORK factory. It should not be arbitrarily changed. If field adjustment is required, a qualified technician can change this value. A special access code is required. Refer to service manual 155.17-M2.

Clock - The Control Center contains an internal clock that is an inherent part of the micro board. It provides the day of the week, time of day, and calendar date. If not programmed, the default value is

SUN 12:00 AM 1/1/92

Daily Schedule - The Control Center can be programmed to automatically start and stop the chiller as desired. This schedule will repeat on a 7-day calendar basis. If the **Daily Schedule** is not programmed, the default value is 00:00 AM start and stop times for all

days of the week and the holiday. (Note that the system will not automatically start and stop on a daily basis with these default values because 00:00 AM is an "impossible" time for the micro board. See "Programming System Setpoints," page 124.) Finally, one or more days in the week can be designated as holidays (see description under **Holiday** setpoint) and the Control Center can be programmed (using **Daily Schedule** setpoint) to automatically start and stop the chiller on those days so designated. The operator can override the time clock at any time using the **UNIT** switch in **LOCAL** mode.

When the Control Center is in **REMOTE** mode configured for FAX-4500 Energy Management System operation (micro board program jumper J56 in "EMS" position and J58 in "RS-485" position), the **Daily Schedule** feature is not operational.

Note that if only a start time is entered for a particular day, the compressor will not automatically stop until a scheduled stop time is encountered on a subsequent day.

Holiday - One or more of the days of the week can be designated as holidays. (See description of **Daily Schedule** above.) On those designated days, the chiller will automatically start and stop per the **Holiday** start and stop times programmed in the **Daily Schedule** setpoint. It will do this one time only and the following week will revert to the normal daily schedule for that day.

Remote Reset Temp Range - This is the maximum allowable offset of the **Leaving Chilled Water** setpoint (**COOLING** mode) or **Leaving Hot Water** setpoint (**HEATING** mode) when operating in **REMOTE** mode. This offset is either 10°F or 20°F as programmed. If not programmed, the default value is 20°F.

In the **COOLING** mode or the **COOLING AND HEATING** mode, this value is added to the operator-programmed **Leaving Chilled Water** setpoint (base) and the sum equals the temperature range in which the setpoint can be reset. For example, if the operator has programmed a setpoint for 46°F (base) into the Control Center, and the **Remote Reset Temp Range** is programmed to be 10°F, then an energy management system can remotely reset the setpoint over the range of 46°F to 56°F (46 + 10 = 56).

In **HEATING** mode, this value is subtracted from the operator-programmed **Leaving Hot Water** setpoint (base) and the result is the temperature range in which the setpoint can be reset. For example, if the operator has programmed a setpoint of 130°F (base) into the Control Center and the **Remote Reset Temp Range** is programmed to be 10°F, then an energy management system can remotely reset the setpoint over the range of 130°F to 120°F (130 - 10 = 120).

Refer to "Field Control Modifications Diagram" Form 155.17-PA1 for details of remote setpoint reset operations.

Data Logger - An optional printer can be connected to the MicroComputer Control Center for data logging

purposes. Refer to "System Status Printers" form for details.

Pull Down Demand - This function is used to provide energy savings by limiting fuel or steam consumption during the first 1 to 255 minutes (programmable) of unit operation following a unit start. Instead of allowing the load command to rapidly increase to 100%, due to the typical high load conditions at start, the load command (gas/oil-fired units) or steam valve position (steam units) is restricted to ramping up from a maximum allowed starting load limit to a maximum allowed stopping load limit over the pull down interval.

When the Control Center is in **REMOTE** mode configured for FAX-4500 Energy Management System operation (micro board program jumper J56 in "EMS" position and J58 in "RS-485" position), the "Pull Down Demand Limit" feature is not operational.

The programmable range is 30 to 100% for gas/oil-fired units and 20 to 100% for steam units. The pull down interval is programmable from 1 to 255 minutes.

Each time the unit starts, a timer begins counting down the pull down interval. Unit loading/unloading is controlled by the automatic temperature control algorithm. However, during the pull down interval, it cannot load to a value greater than the pull down demand limit will allow. The limit ramps linearly from the programmed **START** limit to the programmed **STOP** limit over programmed **INTERVAL** (SETP). The **START** limit is effective when the unit starts. The **STOP** limit is effective when the **INTERVAL** timer has elapsed. The limit at any time in between these points can be determined by:

$$\frac{(\text{STOP LIMIT} - \text{START LIMIT}) T_{\text{ELAPSED}}}{T_{\text{INTERVAL}}} + \text{START LIMIT} = \% \text{ LOAD LIMIT}$$

While the unit is operating and the pull down interval has not yet expired, the present load limit and time remaining in the interval can be viewed by pressing the **Pull Down Demand** setpoint key.

PRESENT PULLDOWN LIMIT = XX%; XXX MIN LEFT

is displayed. After the interval has elapsed, pressing this key displays the programmed interval, start load limit and stop load limit as follows:

SETP = XXX MIN; START = XX%; STOP = XX%

Anytime the interval is in effect and the unit is being prevented from further loading,

SYSTEM RUN - PULL DOWN LIMIT

is displayed. After time out, the pull down limit is no longer in effect.

The following illustrates the load limiting characteristics of a **Pull Down Demand** programmed as follows:

SETP = 60 MIN; START = 40%; STOP = 100%

Each time the unit is started, the load is linearly limited from 40 to 100% for the first 60 minutes of unit operation as follows:

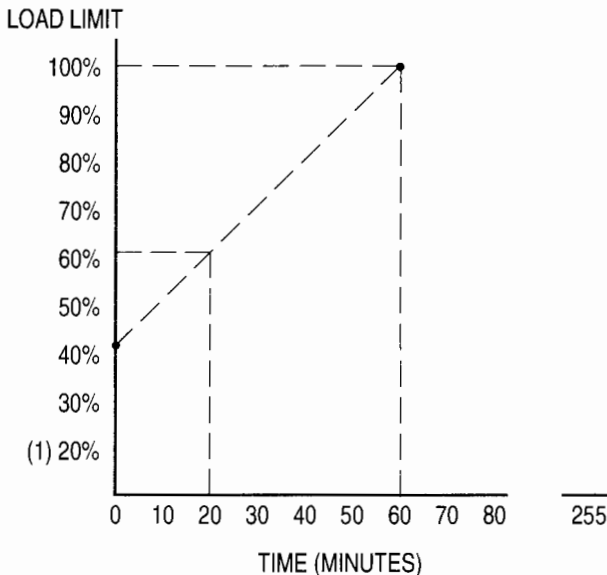

(1) Steam Units

Using the above formula, the load limit at any time during the 60-minute interval can be determined. For example, the load limit 20 minutes after unit has started will be:

$$\frac{(100 - 40) 20}{60} + 40 = 60$$

DISPLAYING SYSTEM SETPOINTS

The currently programmed **SETPOINT** values can be viewed at any time in **SERVICE, LOCAL** or **REMOTE** operating mode as follows:

- Press and **release** the appropriate **SETPOINT** key. The message will be displayed for 2 seconds.
- or -
- Press and **hold** the appropriate **SETPOINT** key. The message will be displayed as long as the key is pressed.
- or -
- Press and **release** the appropriate **SETPOINT** key, then press and release the **DISPLAY HOLD** key. The message will be displayed until the **DISPLAY HOLD** key is again pressed and released or 10 minutes have elapsed, whichever comes first.

NOTE: X's will not be displayed for setpoint values. They are shown to depict number fields only. If micro board program jumper J52 (English/Metric) is installed, all temperatures are displayed in °F. If the jumper is removed, temperatures are displayed in °C.

To Display **LEAVING WATER TEMP** Setpoint:

Use the **Leaving Water Temp** setpoint key as described above to produce the following message:

COOLING Mode:

LVG CHILLED WATER SETPOINT = XX.X° F or

HEATING Mode:

LVG HOT WATER SETPOINT = XXX.X° F

*NOTE: The value displayed in **LOCAL** or **SERVICE** mode is that which was programmed by the operator. The value displayed in **REMOTE** mode is the sum of the operator-programmed value (base) plus any offset (0–20°F) by a remote energy management system.*

To Display **COOL/HEAT CHANGEOVER** Setpoint:

Use the **Cool/Heat Changeover** setpoint key as described above to produce the following message:

SELECTED: COOLING ONLY or

SELECTED: HEATING ONLY or

SELECTED: COOLING AND HEATING

To Display **SPRAY SOL'N PUMP DELAY** Setpoint:

Use the **Spray Sol'n Pump Delay** setpoint key as described above to produce the following message (if micro board program jumper JP3 is OUT, the Control Center is configured for Models 19GL through 22G and 16SL through 19S):

SPRAY SOLUTION PUMP #2 DELAY = XX SEC or

NOT APPLICABLE – SINGLE SOL'N PUMP UNIT

To Display **CLOCK** Setpoint (time of day):

Use the **Clock** setpoint key as described above to produce the following message:

TODAY IS DAY XX:XX AM/PM 1/1/92

To Display **DAILY SCHEDULE** Setpoints:

- Press and **hold** the **Daily Schedule** setpoint key. The chiller start and stop times for each day of the week are sequentially displayed, beginning with Sunday and ending with Holiday. The display will continuously scroll until the **Daily Schedule** key is released.

- or -

- Press and **release** the **Daily Schedule** setpoint key. Then press and **release** the **DISPLAY HOLD** key. The chiller start and stop times for each day of the week are sequentially displayed beginning with Sunday and ending with Holiday. The display will continuously scroll until the **DISPLAY HOLD** key is again pressed and released or 10 minutes have elapsed, whichever comes first.

The display message from **Daily Schedule** will scroll in the following sequence:

SUN START = 08:30 AM STOP = 06:00 PM

MON START = 05:00 AM STOP = 07:00 PM

TUE START = 05:00 AM STOP = 07:00 PM

WED START = 05:00 AM STOP = 07:00 PM

THU START = 05:00 AM STOP = 07:00 PM

FRI START = 05:00 AM STOP = 07:00 PM

SAT START = 05:00 AM STOP = 07:00 PM

HOL START = 00:00 AM STOP = 00:00 PM

To Display **HOLIDAY** Setpoints:

Use the **Holiday** setpoint key as described in the beginning of this section to produce the following message:

S _ M _ T _ W _ T _ F _ S _ HOLIDAY NOTED BY *

*NOTE: On the days that are designated by *, the chiller will automatically start and stop per the holiday schedule established in Daily Schedule setpoints.*

To Display **REMOTE RESET TEMP RANGE** Setpoint:

Use the **Remote Reset Temp Range** setpoint key as described above to produce the following message:

REMOTE RESET TEMP RANGE = 10° F or

REMOTE RESET TEMP RANGE = 20° F

To Display **DATA LOGGER** Setpoints:

See YORK Form 155.17-NO1.2 for operation of this key.

To Display **PULL DOWN DEMAND** Setpoint:

Use **Pull Down Demand** setpoint key as described above to produce the following message:

SETP = XXX MIN; START = XX%; STOP = XX%

NOTE: If unit is operating and a pull down interval is in effect, the following is displayed:

PRESENT PULLDOWN LIMIT = XX%; XXX MIN LEFT

LIBR CONCENTRATION CALCULATOR

The concentration calculator allows the service technician to determine the concentration of any lithium bromide solution without referring to the traditional "PTX" chart. By entering a **SOLUTION TEMPERATURE** and **REFRIGERANT SATURATION TEMPERATURE** or **PRESSURE**, the **CONCENTRATION** is automatically calculated. To use the calculator, proceed as follows:

1. Refer to "Programming the YPC Control Center" section of this book and gain access to **PROGRAM** mode by performing steps 1 through 8. The following message is displayed:

PROGRAM MODE, SELECT SETPOINT

2. Press **OPTIONS** key. This message appears:

WELCOME TO LIBR CONCENTRATION CALCULATOR

3. Press **OPTIONS** key. This message is displayed:

BROMIDE SOLUTION TEMP = 0.0° F

4. Using the **ENTRY** keys, enter a solution temperature. Use leading zeroes where necessary (e.g., 095.0°F). The **CANCEL** key can be used at any time to cancel any entry.

5. Press **ENTER** key.

6. Press **ADVANCE DAY/SCROLL** key. This message is displayed:

SATURATION TEMP = 0.0° F; PRS = 0.00 MM HGA

7. The user has a choice of entering either a refrigerant saturation temperature or pressure. Whichever one is entered, the program automatically calculates and displays the other. Based upon your choice, use one of the procedures below:

- a. To enter the temperature, use the **ENTRY** keys (using leading zeroes where necessary; e.g., 095.0°F). Press the **ENTER** key. The corresponding pressure is displayed.

- or -

- b. To enter the pressure, press the * (asterisk) key. The cursor is moved to the first changeable digit of the pressure entry and

???.?

is displayed for the temperature value. Using the **ENTRY** keys, enter the pressure value (using leading zeroes where necessary; e.g., 070.0mm HgA). Press the **ENTER** key. The corresponding temperature is displayed.

8. Press **ADVANCE DAY/SCROLL** key. If the concentration is not within the crystallization region, the following message is displayed:

SOLUTION CONCENTRATION = XX.X%

If concentration is within the crystallization region, this message appears:

***** CRYSTALLIZATION REGION *****

9. If it is desired to perform further concentration calculations, press **ADVANCE DAY/SCROLL** key to go back to the beginning.

- or -

If it is desired to exit the calculator routine, press the **PROGRAM** key.

PROGRAMMING THE YPC CONTROL CENTER

PROGRAMMING SYSTEM SETPOINTS

The system setpoints can be entered at any time . . . even when the system is running. Proceed as follows to enter system setpoints (refer to Fig. 3).

1. Press **ACCESS CODE** key.
2. This is displayed:

ENTER VALID ACCESS CODE

3. Using **ENTRY** keys, enter **9 6 7 5**.
4. As each digit is entered, the characters **Y O R K** are displayed.

NOTE: If digits other than 9 6 7 5 are entered, Y O R K is still displayed.

NOTE: For ease in remembering the code, note that the letters Y O R K correspond to the digits 9 6 7 5 on a telephone dial.

5. Press **ENTER** key.

NOTE: If digits other than 9 6 7 5 were entered in step No. 4,

INVALID ACCESS CODE

is displayed when the ENTER key is pressed. If this occurs, enter the correct access code (9675) and proceed.

6. This is displayed:

ACCESS TO PROGRAM KEY AUTHORIZED

NOTE: Unless terminated by pressing the ACCESS CODE key again, the operator will have access to the PROGRAM key for 10 minutes. When 10 minutes have elapsed, access to program key will be automatically disabled and the operator must return to step No. 1 to gain access. However, whenever PROGRAM mode is in effect, each key closure will re-initialize the 10-minute timer. Automatic exiting of PROGRAM mode will occur only if no key has been pressed in the last 10 minutes.

7. Press **PROGRAM** key.

8. This is displayed:

PROGRAM MODE, SELECT SETPOINT

9. Enter setpoints as detailed below. If you make a mistake when entering a value, press **CANCEL** key and



FIG. 3 - KEYPAD - PROGRAMMING SYSTEM SETPOINTS

then **ENTER** key. The display will revert to the default values and the cursor will return to the first changeable digit. You can then proceed to enter the correct values. If the entered value exceeds acceptable limits,

OUT OF RANGE - TRY AGAIN!

will be displayed for 2 seconds, then the message

PROGRAM MODE, SELECT SETPOINT

will reappear.

10. When all the desired setpoints have been entered, press the **ACCESS CODE** key to exit **PROGRAM** mode and terminate access to **PROGRAM** mode.

ACCESS TO PROGRAM MODE DISABLED

is displayed. The Control Center will automatically return to **LOCAL**, **REMOTE** or **SERVICE** mode . . . whichever was last selected.

To Enter **LEAVING WATER TEMP** Setpoint:

NOTE: Gas/oil-fired units only: Before this setpoint can be entered, the operator must first determine if the unit is to be operated in the **COOLING ONLY**, **HEATING ONLY** or **COOLING AND HEATING** mode. Press the **COOL/HEAT CHANGEOVER** key to determine if the desired mode (**HEATING** or **COOLING**) has been entered. If it has, proceed with entering the Leaving Water setpoint. Otherwise, program the Cool/Heat Changeover setpoint with the desired mode, then enter the desired Leaving Water Temp setpoint.

COOLING ONLY or **COOLING AND HEATING** mode:
(Refer to Fig. 4)

1. Press and release **LEAVING WATER TEMP** setpoint key. The following program prompt message will be displayed:

LVG CHILLED WATER SETPOINT = XX.X° F (BASE)

(BASE) refers to the base or lowest setpoint available to an energy management system. Refer to previous explanation or "Remote Reset Temp Range," page 120.

HEATING ONLY mode: (Refer to Fig. 5)

1. Press and release **LEAVING WATER TEMP** setpoint key. The following program prompt message will be displayed:

LVG HOT WATER SETPOINT = XX.X° F (BASE)

(BASE) refers to the base or highest setpoint available to an energy management system. Refer to previous explanation or "Remote Reset Temp Range," page 120.

2. Use **ENTRY** keys to enter desired value.
3. Press and release **ENTER** key. This message is displayed:

PROGRAM MODE, SELECT SETPOINT

To Enter **COOL/HEAT CHANGEOVER** Setpoint:
(Refer to Fig. 6)

Steam-Fed Units

1. Press and release **COOL/HEAT CHANGEOVER** setpoint key. The following message is displayed:

COOLING ONLY



FIG. 4 - KEYPAD - PROGRAMMING "LEAVING CHILLED WATER TEMP" SETPOINT

2. Use **ENTRY** keys to enter desired value.
3. Press and release **ENTER** key. This message is displayed:

PROGRAM MODE, SELECT SETPOINT



FIG. 5 - KEYPAD - PROGRAMMING "LEAVING HOT WATER TEMP" SETPOINT

2. It is not necessary to press the **ENTER** key. This selection is automatically entered.
3. Proceed to program the other setpoints as required.

Gas/Oil-Fired Units

Changeover is allowed only if (1) the **UNIT** switch is in **STOP/RESET** position and (2) dilution cycle is not in progress. If a changeover is attempted without meeting this requirement, the following message is displayed:

CHANGEOVER DISABLED DURING RUN/DILUTION

Certain system valve adjustments are required when making a changeover. Refer to YORK Form 155.17-NM1 for details.

1. Press and release the **COOL/HEAT CHANGEOVER** key. The following is displayed:

COOLING MODE - VALVE ADJUSTMENT REQUIRED or

HEATING MODE - VALVE ADJUSTMENT REQUIRED or

COOLING AND HEATING *

* Not applicable to standard "S" series units that do not have a separate heat exchanger (JP2 OUT)

2. Press and release the **ADVANCE/DAY SCROLL** key until the desired mode is displayed.

To Enter the **SPRAY SOL'N PUMP DELAY** Setpoint:

This setpoint can be changed only by a qualified service technician. A special access code is required. Serviceman should refer to instructions in service manual, Form 155.17-M2.

To Enter **CLOCK** Setpoint: (Refer to Fig. 7)

1. Assure micro board program jumper J-57 is in CLKON position.
2. Press and release **CLOCK** setpoint key. The following program prompt message is displayed:

TODAY IS MON 10:30 PM 1/1/92

3. Press **ADVANCE DAY/SCROLL** key until the proper day of week appears on the display.
4. Use **ENTRY** keys to enter proper time of day.
5. Press **AM/PM** key to change AM to PM or vice versa.
6. Use **ENTRY** keys to enter proper calendar date. (MONTH/DAY/YR). If month and day are single digit entries, precede the entry with "0". For example 02/04/93.
7. Press and release **ENTER** key. This message appears:

PROGRAM MODE, SELECT SETPOINT



FIG. 6 - KEYPAD - PROGRAMMING "COOL/HEAT CHANGEOVER" SETPOINT

3. Press and release the **ENTER** key. The following message is displayed:

PROGRAM MODE, SELECT SETPOINT



FIG. 7 - KEYPAD - PROGRAMMING "CLOCK" SETPOINT

To Enter **DAILY SCHEDULE** Setpoint:
(Refer to Fig. 8)

1. Press and release **DAILY SCHEDULE** setpoint key. The following prompt message is displayed:

SUN START = XX:XX AM, STOP = XX:XX AM

2. If the displayed start and stop time is not the desired schedule, enter the desired start and stop times:
 - a. If you don't want the chiller to automatically start and stop on this day, press the **CANCEL** key.
 - b. Use the **ENTRY** keys to enter desired hours and minutes start time.
 - c. If necessary, press the **AM/PM** key to change AM to PM or vice versa.
 - d. Use the **ENTRY** keys to enter desired hours and minutes stop times.
 - e. If necessary, press the **AM/PM** key to change AM to PM or vice versa.
3. Press **ADVANCE DAY/SCROLL** key. The following prompt message is displayed:

MON START = XX:XX AM, STOP = XX:XX AM

4. Enter the desired start and stop time per step 2.
5. Press **ADVANCE DAY/SCROLL** key. The following prompt message is displayed:

REPEAT MON SCHEDULE MON - FRI? YES = 1; NO = 0

To Enter **HOLIDAY** Setpoint: (Refer to Fig. 9)

1. Press and release **HOLIDAY** setpoint key. The following program prompt message is displayed:

S _ M _ T _ W _ T _ F _ S _ HOLIDAY NOTED BY *

2. Press and release **ADVANCE DAY/SCROLL** key to move cursor to the day that you wish to designate as a holiday.
3. Press and release * key. An * will appear next to the selected day.
4. After you have placed an * next to each of the days that you wish to designate a holiday, press the **ENTER** key. The following message is displayed:

PROGRAM MODE, SELECT SETPOINT

To *cancel all* of the designated holidays: perform step 1, press **CANCEL** key, and then press **ENTER** key. This message is displayed:

PROGRAM MODE, SELECT SETPOINT



FIG. 8 - KEYPAD - PROGRAMMING "DAILY SCHEDULE"

- a. If you press the **1** entry key, Monday's start and stop time will be automatically entered for Tuesday through Friday - or -
 - b. If you press the **0** entry key, Tuesday through Friday can be programmed with different start and stop times.
6. Use the **ADVANCE DAY/SCROLL** key with procedure in step 2. To enter start and stop times for remainder of week plus a holiday schedule if required.
 7. Press **ENTER** key. The following message appears:

PROGRAM MODE, SELECT SETPOINT



FIG. 9 - KEYPAD - PROGRAMMING "HOLIDAY" SETPOINT

To *cancel one* of the designated holidays: perform step 1, press **ADVANCE DAY/SCROLL** key until the cursor appears to the right of the desired day, press the * key, then press the **ENTER** key.

To Enter **REMOTE/RESET TEMP RANGE** Setpoint:
(Refer to Fig. 10)

1. Press and release **REMOTE/RESET TEMP RANGE** setpoint key. The following program prompt message is displayed:

REMOTE/RESET TEMP RANGE = XX° F

2. Use **ENTRY** keys to enter desired value (10 or 20).
3. Press and release **ENTER** key. The following message is displayed:

PROGRAM MODE, SELECT SETPOINT



FIG. 10 - KEYPAD - PROGRAMMING "REMOTE RESET TEMP RANGE" SETPOINT

To Enter **DATA LOGGER** Setpoint:

Refer to Form 155.17-02 for operation of this key.

To Enter **PULL DOWN DEMAND** Setpoint:
(Refer to Fig. 11)

1. Press and release **PULL DOWN DEMAND** setpoint key. The following program prompt message is displayed:

SETPOINT = XXX MIN; START = XX%; STOP = XXX%

2. Use **ENTRY** keys to enter desired values. Use leading zeroes where necessary.
3. Press and release **ENTER** key. This message is displayed:

PROGRAM MODE, SELECT SETPOINT



FIG. 11 - KEYPAD - PROGRAMMING "PULL DOWN DEMAND" SETPOINT

To Select **DESIRED PURGE MODE** of Operation:
(Refer to Fig. 11A)

NOTE: This capability exists only with units equipped with EPROM version A.01F.09 (and later) and Automatic Purge Hardware consisting of purge pump pressure transducer (PT3), purge tank pressure transducer (PT4), purge pump and purge tank solenoid valves, and having I/O expansion board program jumper JP1 removed).

1. Press and release **MANUAL PUMP** service key. The following program prompt message is displayed:

PURGE TYPE = X (0 = MAN; 1 = AUTO TANK)

2. Use **ENTRY** keys to enter the digit for the desired purge mode of operation. If the **CANCEL** key is pressed, the default value 1 is displayed.
3. Press **ENTER** key. If 1 was entered in step 2,
 - a. the following message is displayed:

OPEN VP2, CLOSE VP4, THEN PRESS ENTER KEY

IMPORTANT!!!

The manual valves must be adjusted before proceeding to the next step, since an immediate auto purge will occur if the tank pressure is above 60mm HgA.



FIG. 11A - KEYPAD - PROGRAMMING "PURGE MODE" SETPOINT

- b. Press **ENTER** key. This message appears:

PROGRAM MODE, SELECT SETPOINT

If 0 was entered in step 2, the following message is displayed:

PROGRAM MODE, SELECT SETPOINT



FIG. 12 - KEYPAD - SERVICE KEYS LOCATION

The **SERVICE** keys are provided to allow the service technician or operator to have manual control of certain unit functions. Some keys also provide additional information that is helpful in system troubleshooting the unit. **LOAD**, **UNLOAD**, **HOLD**, and **AUTO** keys are enabled in **SERVICE** mode only. The **DISPLAY DATA** and **HISTORY PRINT** keys, and certain **WARNING RESET** functions, are enabled in **LOCAL**, **SERVICE**, or **REMOTE** modes.

UNIT KEYS

LOAD - Press and release this key to cause a continuous load signal to the burner (gas-fired unit, if unit is running), or steam valve (steam-fed unit). If the system is running, this message is displayed:

SYSTEM RUN - UNIT LOADING

If the system is not running, this message is displayed:

SYSTEM READY TO START - UNIT LOADING

When the unit is fully loaded (gas-fired units load command = 100%; steam-fed units steam valve position = 100%),

SYSTEM RUN - UNIT LOADED or

SYSTEM READY TO START - UNIT LOADED

is displayed. The unit will continue to load until the **UNLOAD**, **HOLD**, or **AUTO** (returns to automatic leaving water temp control) key is pressed. The **LOAD** key is also used in **PROGRAM** mode to program the maximum allowed load command. A special access code is required. Refer to service manual, Form 155.17-M2, "Special Programming Features."

UNLOAD - Press and release this key to cause a continuous unload signal to the burner (gas-fired unit, if unit is running) or steam valve (steam-fed unit). If the system is running, this message is displayed:

SYSTEM RUN - UNIT UNLOADING

If the system is not running, this message is displayed:

SYSTEM READY TO START - UNIT UNLOADING

When the unit is fully unloaded (gas-fired units load command = 30%; steam-fed units steam valve position = 0%),

SYSTEM RUN - UNIT UNLOADED

SYSTEM READY TO START - UNIT UNLOADED

is displayed. The unit will continue to unload until the **LOAD**, **HOLD**, or **AUTO** (returns unit to automatic leaving water temp control) key is pressed.

HOLD - Press and release this key to hold the load signal to burner (gas-fired unit) or steam valve (steam-fed unit) at its present position. If the system is running, the following message is displayed:

SYSTEM RUN - UNIT HOLDING

If the system is not running, the following message is displayed:

SYSTEM READY TO START - UNIT HOLDING

The unit will continue holding until the **LOAD**, **UNLOAD** or **AUTO** (returns unit to automatic leaving water temp control) key is pressed.

AUTO - Press and release this key to place the unit in automatic leaving water temperature control. Load and unload signals are applied to the burner (gas-fired unit) or steam valve (steam-fed units) automatically as required to control the leaving water temperature to the desired **Leaving Water Temp** setpoint. This message is displayed:

SYSTEM RUN - AUTO TEMP CONTROL

When the Control Center is in **LOCAL**, **REMOTE**, or **PROGRAM** operating mode, the unit is automatically placed in **AUTO** mode.

On steam-fed units, this key is also used to perform the auto calibration of the steam valve position feedback potentiometer. This operation should be performed only by a qualified service technician. A special access code is required. The service technician should refer to the calibration procedure in service manual 155.17-M2.

OTHER SERVICE KEYS

WARNING RESET - This key is used (in any operating mode) to turn off the audible alarm that is turned on by the occurrence of any of the following warning conditions. This key is also used (in **SERVICE** mode) to clear the warning message (after the condition that caused the alarm has reached the **RESET** threshold). Refer to description of warning messages in "Display Messages" section.

MANUAL PUMP - This key is used to (1) manually control the individual system pumps, (2) perform a manual dilution cycle, and (3) select purge mode (if unit equipped with EPROM version A.01F.09 or later and also equipped with the Automatic Purge Hardware with I/O expansion board program jumper JP1 removed).

PURGE PUMP - The purge pump can be manually operated in **LOCAL**, **REMOTE** or **SERVICE** mode. It will

turn off only when manually turned off. Those units equipped with EPROM version A.01F.09 (or later) that are also equipped with the Automatic Purge Hardware (I/O expansion board program jumper JP1 removed) must have "Manual Purge" operation selected in order to manually operate the purge pump. Refer to "Theory of Operation" section in front of this book for detailed instructions on purge pump operation. Refer to purge mode selection instructions in "Programming the ParaFlow Control Center" section of this book.

ALL OTHER PUMPS & MANUAL DILUTION CYCLE - Place Control Center in **SERVICE** mode. Press and hold the **PUMP STATUS** key until the desired function is displayed. The **DISPLAY HOLD** feature is automatically engaged when using the **PUMP STATUS** key. The functions will scroll in this order:

- PURGE PUMP – OFF – MANUAL PURGE**¹
- PURGE PUMP – OFF – AUTO TANK PURGE**¹
- REFRIGERANT PUMP – OFF**²
- SOLUTION PUMP – OFF**²
- CHILLED WATER PUMP – OFF**²
- CONDENSER WATER PUMP – OFF**²
- HOT WATER PUMP – OFF**² (gas/oil units only)
- SECOND SPRAY SOLUTION PUMP – OFF**² (Models 19GL–22G & 16SL–19S only)
- MANUAL DILUTION CYCLE – OFF**³

¹ The actual purge pump message displayed is determined by which purge type is selected. Units equipped with EPROM version A.01F.09 (or later) that are also equipped with the Automatic Purge Hardware

(I/O expansion board program jumper JP1 removed) can have "Manual Purge" or "Auto Tank Purge" selected. All other units have "Manual Purge" capability only. Refer to purge mode selection instructions in "Programming the ParaFlow Control Center" section of this book. Also refer to description of purge operation in "Theory of Operation" section of this book.

² This pump can be manually operated if (a) the Control Center is in **SERVICE** mode and (b) the **UNIT** switch is in **STOP/RESET** and (c) no dilution cycle is in progress. Anytime the pump is turned on, it will remain on until (a) it is manually turned off or (b) 2 hours have elapsed or (c) the **UNIT** switch is moved from **STOP/RESET** position to **RUN** position.

Press and release the **MANUAL PUMP** key. The displayed message will change from

< FUNCTION > – OFF to

< FUNCTION > – ON or vice versa.

PURGE MODE SELECTION - Units equipped with EPROM version A.01F.09 (or later) that are also equipped with the Automatic Purge Hardware (I/O expansion board program jumper JP1 removed) have 2 modes of purge operation: "Manual Purge" and "Auto Tank Purge". The **MANUAL PUMP** key is used, in **PROGRAM** mode, to select the desired mode. Refer to instructions in "Programming the ParaFlow Control Center" section of this book. Also refer to purge explanation in "Theory of Operation" section of this book.

³ A manual dilution cycle can only be initiated if (a) the Control Center is in **SERVICE** mode and (b) the **UNIT** switch is in **STOP/RESET** position and (c) the unit is not presently performing a dilution cycle and (d) the unit is not presently shut down due to the solution or refrigerant pump overloads or thermal switches, chilled water flow switch or low refrigerant temperature. When the dilution cycle is manually initiated (ON), it will automatically terminate when the dilution cycle is complete. However, it can be stopped at any time during the cycle by pressing and releasing the **MANUAL PUMP** key.

DISPLAY DATA - Press and hold this key. The messages below will scroll sequentially on the display. Each will be displayed for 2 seconds. Or, to hold each of these messages, press and release the **DISPLAY HOLD** key, then press and release the **DISPLAY DATA** key. Each time the **DISPLAY DATA** key is pressed, the next message is displayed. To terminate these displays, press **DISPLAY HOLD** key again.

- 1 **PURGE PUMP PRESSURE = XX.XMM HGA**
- 1 **PURGE TANK PRESSURE = XX.XMM HGA**
- 5 **BURNER LOAD COMMAND = XXX%**
- 6 **STEAM VALVE POSITION = XXX%**
- 7 **REMOTE LOAD LIMIT = XXX%**
- 2 **2ND STAGE LVG REFRIG TEMP = XXX.X° F**
- 3 **LOW REFRIGERANT TEMP CUTOUT = XX.X° F**
- 4 **MIXED WATER TEMP = XX.X° F**

¹ Displayed only if unit is equipped with EPROM version A.01F.09 (or later) and Automatic Purge Hardware (I/O expansion board program jumper JP1 removed).

² Temperature as sensed by thermistor RT12. Temperature is used in conjunction with 1st stage generator temperature for the automatic solution concentration calculator. Refer to "Warning-Concentration Override" warning message and "Day-Time-High Solution Concentration" safety shutdown message in "Display Messages" section of this book. Displayed only with EPROM version A.01F.09 or later.

³ Temperature displayed is the value the program is using as the low refrigerant temp safety cutout threshold. If I/O expansion board program jumper J13 is removed, the threshold is always 35.0°F. If program jumper is installed, the threshold is variable and is determined by the relationship of the entering and leaving condenser water temperature. Refer to "Day-Time-Low Refrigerant Temp-Analog" safety shutdown message in "Display Messages" section of this book.

⁴ This message is only displayed if the optional mixed water temp thermistor is connected to the micro board and it is not "out of range" at the low end.

⁵ Displayed for gas/oil-fired units only (micro board program jumper JP1 must be IN.) This is the load command (as a percent of full load) that is being applied to the burner. The load command is a 3-22 mA signal that corresponds to 30-100% load while the unit is operating.

⁶ Displayed for steam-fed units only (micro board program jumper JP1 must be OUT.) This value represents the present position of the steam valve. It is provided by the steam valve position feedback potentiometer. The range is 0-100%. The minimum position during unit operation is factory-set by the steam valve actuator limit switch.

⁷ Displayed for (a) all STEAM units (micro board program jumper JP1 must be OUT) in **REMOTE** mode (b) only those GAS/OIL units connected to FAX-4500 Energy Management System (micro board program jumper J56 must be in the EMS position) in **REMOTE** mode.

Steam Units (Note 7)

- This value (20-100% steam valve position) is input from a FAX-4500 EMS to the RS-485 serial port TB7 or from a remote device in PWM form (1-11 seconds) to the relay board terminal 82. The steam valve will be limited to this position during "System Run." While the unit is in "System Run," the steam valve is not allowed to unload below 20% of unit capacity. The actual steam valve position that corresponds to 20% of unit capacity could be different for each unit. Twenty percent (20%) capacity of a given unit could be, for example, 40% steam valve position. Units equipped with Honeywell steam valves have a limit switch that opens to prevent the valve from unloading to less than 20% of unit capacity. Therefore, even though the **Remote Load Limit** attempts to limit the steam valve position to a certain percentage of full travel, it will not be permitted to unload further than the limit switch will allow.

On steam units equipped with Leslie steam valves, the steam valve position corresponding to 20% of unit capacity is set by the **Minimum Allowed Loading** setpoint. The steam valve is inhibited from unloading to less than this position. If a remote device attempts to limit the loading to a valve position that is less than or equal to the **Minimum Allowed Loading** setpoint, the MicroComputer Control Center will override the remote device as follows: If a **Remote Load Limit** setpoint is received that is not greater than the **Minimum Allowed Loading** setpoint, the program will automatically set the **Remote Load Limit** setpoint to 1% above the **Minimum Allowed Loading** setpoint.

Gas/Oil Units (Note 7)

- Only displayed if micro board program jumper J56 is in EMS position. Value displayed (30-100%) is result of command input to micro board RS-485 serial port from FAX-4500 Energy Management System. The load command to the burner will be limited to this value (30-100%).

HISTORY PRINT - Press and release this key to initiate a history print to the optional printer. Upon pressing this key, the following message is displayed:

HISTORY PRINT ENABLED

If a history print is already in progress, this message appears:

HISTORY PRINT REQUEST IN PROGRESS . . .

If there have been fewer than 4 cycling or safety shutdowns,

HISTORY PRINT ENABLED

is displayed when the key is pressed. Refer to YORK Form 155.17-NO1.2 for details of the optional printer operation.

OPERATING MODES

The YPC Control Center can be operated in four different operating modes as follows:

SERVICE - Enables all the **SERVICE** keys except **DISPLAY DATA** and **HISTORY PRINT**, which are enabled in all modes. See "Service Keys", page 130.

LOCAL - This is the normal operating mode. The unit can be started and stopped from the Control Center. Also, the **Display** and **Setpoints** parameters can be displayed.

PROGRAM - Allows the operator to program the **Setpoints** parameters and change operating modes.

REMOTE - In this mode, the Control Center will accept control signals from a remote device (i.e., Energy Management System) or cycling inputs. The control signal inputs are:

1. Remote Start
2. Remote Stop
3. Remote Leaving Chilled Water (all units) or Leaving Hot Water Temp Setpoint (gas/oil-fired units only)
4. Remote Load Limit Setpoint

NOTE: The unit can be stopped by the UNIT switch, regardless of the operating mode. The switch must be in RUN position to enable REMOTE mode. The operator cannot locally start the unit using the UNIT switch when in the REMOTE mode.

To determine which operating mode the Control Center is presently in, simply press the **MODE** key.

- If the Control Center is in **LOCAL** mode, this message is displayed:

LOCAL OPERATING MODE IN EFFECT

- If the Control Center is in **REMOTE** mode, this message is displayed:

REMOTE OPERATING MODE IN EFFECT

- If the Control Center is in **SERVICE** mode, this is displayed:

SERVICE OPERATING MODE IN EFFECT

To change operating mode, proceed as follows:

1. Press **ACCESS CODE** key.
2. This message appears:

ENTER VALID ACCESS CODE _ _ _ _

3. Using **ENTRY** keys, enter 9 6 7 5.
4. As each digit is entered, the characters **Y O R K** are displayed.

NOTE: If digits other than 9 6 7 5 are entered, Y O R K is still displayed.

5. Press **ENTER** key.

NOTE: If digits other than 9 6 7 5 were entered in step No. 4,

INVALID ACCESS CODE

is displayed when the "ENTER" key is pressed. If this occurs, enter the correct access code (9 6 7 5) and proceed.

6. This message is displayed:

ACCESS TO PROGRAM KEY AUTHORIZED

NOTE: Unless terminated by pressing the ACCESS CODE key again, the operator will have access to the PROGRAM key for 10 minutes. When 10 minutes have elapsed, access to PROGRAM key will be automatically disabled and the operator must return to step No. 1 to gain access.

7. Press **PROGRAM** key.

8. This message is displayed:

PROGRAM MODE, SELECT SETPOINT

9. Press **MODE** key.

10. The mode that has been previously selected will be displayed as follows:

LOCAL MODE SELECTED or

SERVICE MODE SELECTED or

REMOTE MODE SELECTED

11. Press **ADVANCE DAY** key to scroll to desired mode. Each time this key is pressed, a different mode is displayed as above.

12. When the desired mode is displayed, press **ENTER**.

13. This message is displayed:

PROGRAM MODE, SELECT SETPOINT

14. Press **ACCESS CODE** key to exit **PROGRAM** mode and terminate access to **PROGRAM** mode.

15. This message is displayed:

ACCESS TO PROGRAM MODE DISABLED

UNIT SWITCH

(Refer to Fig. 12, page 129)

This rocker switch is used to locally operate the unit. It is used to start, run and stop the compressor. Also, it resets the Control Center after a safety shutdown.

To **START** unit in **LOCAL** mode:

Move **UNIT** switch from **STOP/RESET** to **START** position. Switch will spring-return to **RUN** position.

To **STOP** the unit:

Move switch from **RUN** to **STOP/RESET** position.

To **RESET** Control Center:

Following a safety shutdown, the operator is required to reset the Control Center prior to restarting the system. Move switch from **RUN** to the **STOP/RESET** position.

*NOTE: The operator cannot start the unit (using this switch) when the Control Center is in the **REMOTE** mode.*

DISPLAY MESSAGES

SYSTEM READY TO START:

SYSTEM READY TO START

System has no status message to report and will start when a start signal is applied.

SYSTEM READY TO START – DILUTION

Same as above, but a dilution cycle is in progress.

SYSTEM READY TO START – PRESS STATUS

System will start when a start signal is applied. The operator is instructed to press the **STATUS** key to view a status message.

SYSTEM READY TO START – DIL'N – PRESS STATUS

Same as above, but a dilution cycle is in progress.

SYSTEM READY TO START – PURGE OL FAULT

System will start when a start signal is applied. However, the purge pump (M3) Motor Protector (MP3) or Motor Thermal Switch (MTH3) has opened. Therefore, no automatic purge cycles will occur (if unit is equipped with optional auto-purge system). Also, manual purge cycles cannot be performed. If the motor protector has opened, it requires a manual reset. The thermal switch automatically recloses.

SYSTEM READY TO START – UNIT HOLDING

or

SYSTEM READY TO START – UNIT LOADING

or

SYSTEM READY TO START – UNIT LOADED

or

SYSTEM READY TO START – UNIT UNLOADING

or

SYSTEM READY TO START – UNIT UNLOADED

Control Center is in **SERVICE** mode. The system will start when a start signal is applied. It is in the process of holding, loading, or unloading or is in the fully loaded or unloaded position.

SYSTEM START SEQUENCE:

COOLING START SEQUENCE INITIATED

The system has received a start signal but has not yet achieved the run state. The Control Center is operating in **COOLING ONLY** or **COOLING AND HEATING** mode and is being controlled by the **Leaving Chilled Water** setpoint.

HEATING START SEQUENCE INITIATED

The system has received a start signal but has not yet achieved the run state. The Control Center is operating in **HEATING ONLY** mode and is being controlled by the **Leaving Hot Water** setpoint.

SYSTEM RUN:

SYSTEM RUN – PRESS STATUS

The system is running in **LOCAL**, **REMOTE** or **SERVICE** mode. The operator is instructed to press the **STATUS** key to display a status message.

SYSTEM RUN – MAXIMUM COOLING

The system is running in **LOCAL**, **REMOTE** or **SERVICE**

operating mode. It is operating at maximum capacity in **COOLING ONLY** or **COOLING AND HEATING** mode. The load command is equal to the **Maximum Allowed Loading** value that has been programmed by the YORK factory or field serviceman using the "Special Programming Features" in the service manual, Form 155.17-M2.

IMPORTANT!!!

*Gas/oil-fired units are allowed to load beyond any programmed or remote load limits until **Burner Calibration Full Travel Calibration** is performed.*

SYSTEM RUN – MAXIMUM HEATING

(Applies to gas/oil-fired units only.) The system is running in **LOCAL**, **REMOTE** or **SERVICE** operating mode. It is operating at maximum capacity in **HEATING ONLY** mode. The load command is equal to the **Maximum Allowed Loading** value that has been programmed by the YORK factory or field serviceman using the "Special Programming Features" in the service manual, Form 155.17-M2.

IMPORTANT!!!

*Gas/oil-fired units are allowed to load beyond any programmed or remote load limits until **Burner Calibration Full Travel Calibration** is performed.*

SYSTEM RUN – MINIMUM ALLOWED LOADING

(Applies only to steam units equipped with EPROM version A.01F.08 or later and Leslie steam valves.) Displayed when the unit has unloaded to the programmed **Minimum Allowed Loading** setpoint. This setpoint is set by the field service technician to the valve position that corresponds to 20% of unit capacity. The unit will not be allowed to unload below this valve position. Below this position, instability in operation results.

SYSTEM RUN – PULL DOWN LIMIT

System is running in **LOCAL**, **REMOTE** or **SERVICE** mode. The loading is being inhibited by the programmed **Pull Down Demand** setpoint.

SYSTEM RUN – REMOTE LOAD LIMIT

System is running in **REMOTE** mode and the unit loading is being inhibited by the **Remote Load Limit** command from a remote device. The load limit value that is in effect can be viewed by pressing the **DISPLAY DATA** keypad key in **REMOTE** mode.

On steam units, this value (20–100% steam valve position) is input from a FAX-4500 EMS to the RS-485

serial port TB7 or from a remote device in PWM form (1–11 seconds) to the relay board terminal 82. The steam valve will be limited to this position during "System Run." While the unit is in "System Run," the steam valve is not allowed to unload below 20% of unit capacity. The actual steam valve position that corresponds to 20% of unit capacity could be different for each unit. Twenty percent (20%) capacity of a given unit could be, for example, 40% steam valve position. Units equipped with Honeywell steam valves have a limit switch that opens to prevent the valve from unloading to less than 20% of unit capacity. Therefore, even though the **Remote Load Limit** attempts to limit the steam valve position to a certain percentage of full travel, it will not be permitted to unload further than the limit switch will allow.

On steam units equipped with Leslie steam valves (EPROM version A.01F.08 or later), the steam valve position corresponding to 20% of unit capacity is set by the **Minimum Allowed Loading** setpoint. The steam valve is inhibited from unloading to less than this position. If a remote device attempts to limit the loading to a valve position that is less than or equal to the **Minimum Allowed Loading** setpoint, the MicroComputer Control Center will override the remote device as follows: If a **Remote Load Limit** setpoint is received that is not greater than the **Minimum Allowed Loading** setpoint, the program will automatically set the **Remote Load Limit** setpoint to 1% above the **Minimum Allowed Loading** setpoint.

On gas/oil-fired units, this value (30–100%) is input from a FAX-4500 EMS to the RS-485 serial port TB7.

IMPORTANT!!!

*Gas/oil-fired units are allowed to load beyond any programmed or remote load limits until **Burner Calibration Full Travel Calibration** is performed.*

SYSTEM RUN – LEAVING CHILLED WATER CONTROL

The system is running in **LOCAL** or **REMOTE** mode. The loading and unloading is being automatically controlled by the **Leaving Chilled Water** setpoint. There are no status messages.

SYSTEM RUN – LEAVING HOT WATER CONTROL

The system is running in **LOCAL** or **REMOTE** mode. The loading and unloading is being automatically controlled by the **Leaving Hot Water Temp** setpoint. There are no status messages.

SYSTEM RUN – UNIT LOADING

or

SYSTEM RUN – UNIT LOADED

or

SYSTEM RUN – UNIT UNLOADING

or

SYSTEM RUN – UNIT UNLOADED

The system is running in **SERVICE** mode. It is in the process of loading or unloading due to the operator pressing the **LOAD** or **UNLOAD** keys or because of automatic control by the **Leaving Chilled Water** setpoint or **Leaving Hot Water** setpoint. Or it is in the fully loaded or unloaded position.

SYSTEM RUN – UNIT HOLDING

The system is running in **SERVICE** mode. The load command is in the process of holding because the operator has pressed the **HOLD** key. The load command is unchanging.

SYSTEM RUN – AUTO TEMP CONTROL

The system is running in **SERVICE** mode. The loading and unloading is being automatically controlled by the **Leaving Chilled Water Temp** setpoint (**COOLING ONLY** or **COOLING AND HEATING** mode) or **Leaving Hot Water Temp** setpoint (**HEATING ONLY** mode). However, it is presently not loading or unloading. The load command is **HOLD**.

SYSTEM RUN – COLD STACK FIRING LIMIT

(Applies to gas/oil-fired units only.) Displayed while the **Auto-Temp Control Delay** is maintaining the burner at minimum fire preventing unstable burner operation due to a cold stack. The **Auto-Temp Control Delay** is programmable from 0–10 minutes and can only be changed by a qualified service technician. (Refer to service manual, YORK Form 155.17-M2.)

SYSTEM SHUTDOWN:**SYSTEM SHUTDOWN – PRESS STATUS**

The system is shut down due to a cycling or safety shutdown. Pressing the **STATUS** key displays the day, time and cause of shutdown.

SYSTEM SHUTDOWN – DILUTION – PRESS STATUS

Same as above but a dilution cycle is presently in progress.

STATUS MESSAGES:**Cycling Shutdowns****SUN 12:00 AM HW FLOW SWITCH – AUTO START**

Hot water flow switch has opened for 2 continuous seconds while unit was running. This check is bypassed for the first 30 seconds of a start sequence. It is only performed on gas-fired units (micro board program jumper JP1 must be IN) operating in **HEATING ONLY** mode. The unit will automatically restart when the flow switch closes.

SUN 12:00 AM COND FLOW SWITCH – AUTO START

Condenser flow switch has opened for 2 continuous seconds while unit was running. This check is bypassed for the first 30 seconds of a start sequence. The unit will automatically restart when the flow switch closes. If the unit is equipped with EPROM version A.01F.07 (or earlier), if the flow switch does not close within 30 minutes, the cycling shutdown becomes a safety shutdown. Refer to message “Day-Time-Cond Flow Switch”.

If the unit is equipped with EPROM version A.01F.08 (or later), if the flow switch closes before the dilution terminates, the unit will automatically restart. However, if it does not close before the dilution terminates, the cycling shutdown becomes a safety shutdown. Refer to message “Day-Time-Cond Flow Switch”.

SUN 12:00 AM POWER FAILURE – AUTO START

A power failure has occurred with the Control Center operating in “Auto-Restart After Power Failure” mode (micro board program jumper JP50 is IN). If the unit is running when the power failure occurs, it will automatically restart when power is restored.

SUN 12:00 AM LOW WATER TEMP – AUTO START

The leaving chilled water temperature has decreased to $>3^{\circ}\text{F}$ below the **Leaving Chilled Water Temp** setpoint or has decreased to $<40^{\circ}\text{F}$. If the setpoint is $>43.0^{\circ}\text{F}$, the unit will automatically restart when the water temperature increases to $\geq 1^{\circ}\text{F}$ above the setpoint. If the setpoint is $<43.0^{\circ}\text{F}$, the unit will automatically restart when the water temperature increases to $\geq 44.0^{\circ}\text{F}$. If the setpoint is increased while the unit is running, the shutdown threshold remains the same as the previous threshold for 30 minutes to eliminate nuisance trips. (This check is only made when the unit is in **COOLING ONLY** or **COOLING AND HEATING** mode.)

SUN 12:00 AM LVG WATER TEMP < SETPOINT

The unit is shut down for any reason other than “SUN 12:00AM LOW WATER TEMP – AUTOSTART” and the leaving chilled water temperature is less than the **Leaving Chilled Water Temp** setpoint. It will be allowed to start when the water temperature is equal to or greater than the setpoint. If a start signal is applied while shut down with this condition, the unit will automatically start when the condition clears. (This check is only performed in **COOLING ONLY** or **COOLING AND HEATING** mode.)

NOTE: This check is not performed if the unit has shut down on

SUN 12:00 AM LOW WATER TEMP – AUTO START

*If the unit has shut down on **Low Water Temp**, then the criterion for that restart applies.*

SUN 12:00 AM SYSTEM CYCLING – AUTO START

A remote device (Energy Management System, time clock, etc.) connected to the **REMOTE/LOCAL** cycling input (TB2-1 and 13) of the digital input board has shut down the unit. Relay contacts or switch connected from 1 to 13 will cycle unit in **LOCAL** or **REMOTE** mode. When the contacts are closed, the unit runs. When the contacts open, the unit shuts down.

SUN 12:00 AM MULTI-UNIT CYCLING – AUTO START

A remote device (Energy Management System, time clock, multi-unit sequencer, etc.) connected to the **Multi-Unit** sequence input (TB2-1 and 9) of the digital input board has shut down the unit. Relay contacts or switch connected from 1 to 9 will cycle unit in **LOCAL** or **REMOTE** mode. When the contacts are closed, the unit runs. When the contacts open, the unit shuts down.

SUN 12:00 AM INTERNAL CLOCK – AUTO START

The operator-programmed daily stop schedule (**Daily Schedule** setpoint) has shut down unit. The unit will automatically restart when the operator-programmed daily start schedule initiates a start. It can be overridden by pressing the **UNIT** switch to **START** position.

SUN 12:00 AM HIGH WATER TEMP – AUTO START

The unit has shut down because the leaving hot water temperature has increased to $>5^{\circ}\text{F}$ above the **Leaving Hot Water** setpoint. The unit will automatically restart when the leaving hot water temperature decreases to $>10^{\circ}\text{F}$ below the setpoint. If the leaving hot water temperature setpoint is decreased while the unit is running, the **High Water Temp** shutdown threshold becomes 155°F (“G” series units with standard heat exchanger), 175°F (“S” and “G” series with high temp heat exchanger), 145°F (standard “S” series without heat exchanger) for 30 minutes to eliminate nuisance trips. (This check is only made when the Control Center is operating in **HEATING ONLY** mode.)

SUN 12:00 AM LVG WATER TEMP > SETPOINT

The unit is shut down for any reason except “SUN 12:00AM HIGH WATER TEMP – AUTOSTART” and the leaving hot water temperature is greater than the **Leaving Hot Water Temp** setpoint. It will be allowed to start when the leaving hot water temperature is less than or

equal to the setpoint. If a start signal is applied while shut down under this condition, the unit will automatically start when this condition clears. (This check is only performed in **HEATING ONLY** mode.)

NOTE: This check is not performed if the unit has shut down on

SUN 12:00 AM HIGH WATER TEMP – AUTO START

*If the unit has shut down on **High Water Temp**, then the criterion for that restart applies.*

SUN 12:00 AM STEAM VALVE LOADED ABOVE 10%

The unit is shut down for any reason and the steam valve remains at a position that is greater than or equal to 10% load. Steam-fed units (micro board program jumper JP1 is OUT) are not allowed to start until the steam valve position decreases to $<9\%$.

SUN 12:00 AM LOAD COMMAND ABOVE 30%

(Applies to gas/oil units only.) This message indicates that the unit is shut down and a start has been initiated and the burner load command is above 30%. Gas/oil units are not allowed to start while the load command is greater than 30%. The unit will automatically start when the load command decreases to 30%.

SUN 12:00 AM – FLS – LIMITED DIL’N OVERRIDE

(where FLS = Condenser Flow Switch). Condenser water flow is not permitted during a “Limited Dilution” cycle. If condenser water flow is sensed, through the condenser flow switch closure, the limited dilution is terminated and this message is displayed. If flow subsequently ceases, the limited dilution will resume if the solution dilution temperature (as measured by thermistor RT11) is $>136^{\circ}\text{F}$. If the solution temperature is $\leq 136^{\circ}\text{F}$, the dilution will not resume and “Day-Time-LD-Chk Sol’n Level-Abs & Gen” is displayed.

SUN 12:00 AM SOL’N PUMP ONLY DIL’N CYCLE

Displayed when a “Limited Dilution” cycle is in progress. Time displayed is the time the limited dilution was initiated. Limited dilutions are performed when the Control Center is powered by a standby power supply during power failures.

SUN 12:00 AM STANDBY POWER – UNIT LOCKOUT

Displayed while the MicroComputer Control Center is being powered by a standby power supply and the “Limited Dilution” cycle is completed or was not required because the unit was not running when the power failure occurred. Whenever a standby power supply is providing power to the MicroComputer Control Center, it will close a set of

external relay contacts connected to the digital input board TB2-95 to TB2-1. While this is displayed, the unit cannot be started and all other unit operations are inhibited and cannot be performed even with manual override.

Safety Shutdowns:

SUN 12:00 AM SOLUTION PUMP OVERLOADS OPEN

Unit has shut down because the solution pump (M1) motor protector (1OL) or motor thermal switch (MTH1) has opened. To restart the unit, press **UNIT** switch to **STOP/RESET** position, reset the **MOTOR PROTECTOR** (if tripped), then press the **UNIT** switch to the **START** position. If the shutdown was caused by the **thermal switch**, the thermal switch does not have to be reset; it automatically recloses. The motor protector is located in the power panel. The thermal switch is located inside the motor (M1).

Models 19GL through 22GL have two spray solution pumps (M4 and M5) in addition to the solution pump (M1) listed above. Spray solution pump No. 1 (M4) is protected by motor protector (4OL) and thermal switch (MTH4). Spray solution pump No. 2 (M5) is protected by motor protector (5OL) and thermal switch (MTH5). Models 16SL through 19S have a solution pump and a spray solution pump. The solution pump is protected by motor protector (1OL) and motor thermal switch (MTH1). The spray solution pump is protected by motor protector (4OL) and motor thermal switch (MTH4).

If any one of the above motor protectors or thermal switches opens, the unit will shut down.

SUN 12:00 AM REFRIG PUMP OVERLOADS OPEN

Unit has shut down because the refrigerant pump (M2) motor protector (2OL) or motor thermal switch (MTH2) has opened. To restart the unit, press **UNIT** switch to **STOP/RESET** position, reset the **MOTOR PROTECTOR** (if tripped), then press the **UNIT** switch to the **START** position. If the shutdown was caused by the **thermal switch**, the thermal switch does not have to be reset; it automatically recloses. The motor protector is located in the power panel. The thermal switch is located inside the motor (M2).

Normal dilution cycles are not performed on refrigerant pump overload safety shutdowns.

SUN 12:00 AM - PO - CHK SOL'N LEVEL - ABS & GEN

(where PO = Pump Overload). This message indicates the solution dilution temperature (as measured by thermistor RT11) was <136°F when the solution pump or refrigerant pump overload reclosed during an overload shutdown.

Since a dilution cycle does not occur when the unit shuts down on a solution pump or refrigerant pump overload

and the solution dilution temperature has cooled to <136°F while it was shut down, it is possible that crystallization has occurred during the shutdown. Therefore, this message is advising the operator to check the solution level in the absorber and generator prior to restarting the unit. If any of these areas indicate a low liquid level, crystallization has possibly occurred. Refer to YORK Form 155.17-NM1 for details of decrystallization.

After it has been determined that crystallization has not occurred, the unit can be restarted by placing the **UNIT** switch in the **STOP/RESET** position, then pressing the **WARNING/RESET** key in **SERVICE** mode and then initiating a start.

SUN 12:00 AM 1ST STAGE GEN HIGH PRESS - DIG

(where DIG = Digital Initiated Shutdown). The unit has shut down because the first stage generator high pressure safety device (HP1) has opened. It is calibrated to open at 709.8mm HgA (13.73 PSIA). It will automatically reclose at 39.8mm HgA (0.77 PSIA). To restart unit, press **UNIT** switch to **STOP/RESET** position, then to **START** position.

Gas/oil-fired models 20G through 22G have two first stage generators. Each has its own safety device. Generator No. 1 is protected by HP1. Generator No. 2 is protected by HP2. If either safety device HP1 or HP2 opens, the unit will shut down.

SUN 12:00 AM 1ST STAGE GEN HIGH PRESS - ANA

(where ANA = Analog Initiated Shutdown). The unit has shut down because the first stage generator pressure, as sensed by pressure transducer PT1 (and PT2 if Models 20G through 22G) has increased to 775.5mm HgA (15.00 PSIA). It will be allowed to restart when pressure decreases to <775.5mm HgA (<15.00 PSIA). To restart unit, press the **UNIT** switch to **STOP/RESET** position, then to **START** position.

This analog check acts as a back-up check to the digital check performed by safety device HP1 (and HP2 if Model 20G through 22G). HP1 and HP2 are calibrated to trip at 709.8mm HgA (13.73 PSIA).

SUN 12:00 AM 1ST STG GEN HI TMP - MAN RESET

The unit has shut down because the first stage generator high temperature safety device (HT1) has opened. It is calibrated to open at 330°F. It will close when manually reset (if temp ≤329°F). To restart unit, press the **UNIT** switch to **STOP/RESET** position, manually reset **HT1**, then press **UNIT** switch to **START** position.

Gas/oil-fired models 20G through 22G have two first stage generators. Each has its own high temperature safety device. Generator No. 1 is protected by HT1. Generator No. 2 is protected by HT2. If either safety device HT1 or HT2 remains open for more than 1 sec-

ond, the unit will shut down. This delay prevents nuisance shutdowns on units equipped with dual fuel burners when the burner is switched to the alternate fuel while running.

SUN 12:00 AM 1ST STG GEN HIGH TEMP – ANA

(where ANA = Analog Initiated Shutdown). The unit has shut down because the first stage generator temperature as sensed by thermistor RT6 (and RT7 if Model 20G through 22G) has increased to 337°F. It will be allowed to restart when temperature decreases to <337°F. To restart unit, press **UNIT** switch to **STOP/RESET**, then to **START**.

This analog check acts as a back-up to the digital check performed by safety device HT1 (and HT2 if Model 20G through 22G). HT1 and HT2 are calibrated to trip at 330°F.

SUN 12:00 AM AUXILIARY SAFETY SHUTDOWN

The unit has shut down because an external device connected to digital input board TB1–31 has initiated a shutdown. This input is a general purpose input that can be used to enunciate a user-defined safety shutdown. Typical application is normally open contacts that close to apply 115 VAC to TB1–31 to initiate a shutdown. The unit will be allowed to restart when the contacts are open. To restart unit, press the **UNIT** switch to **STOP/RESET** position, then to **START** position.

SUN 12:00 AM POWER FAILURE – MANUAL RESTART

The chiller has shut down because there has been a power failure or interruption with the Control Center configured for “Manual Restart After Power Failure” (micro board program jumper J50 is OUT). After power is restored, the unit can be restarted by pressing the **UNIT** switch to **STOP/RESET** position, then to **START** position.

SUN 12:00 AM 1ST STAGE GEN LO SOL'N LEVEL

(Applies to gas/oil-fired units only.) The unit has shut down because the first stage generator **solution level detector switch** (LS) has opened due to insufficient level. The switch will automatically reclose when there is sufficient level. To restart unit, press **UNIT** switch to **STOP/RESET** position, then to the **START** position.

Gas/oil-fired models 20G through 22G have two first stage generators. Each generator has its own level sensor, connected to a switch that is common to both sensors. If either sensor detects a low level condition, it causes the level detector switch (LS) to open.

SUN 12:00 AM LOW REFRIGERANT TEMP – DIGITAL

The unit has shut down because the low refrigerant tem-

perature safety device (LRT) has opened. It is calibrated to open at 35.0°F. It will automatically reclose at 40.0°F. To restart unit, press **UNIT** switch to **STOP/RESET** position, then to **START** position. (This check is not applicable when operating in **HEATING ONLY** mode.)

When the LRT safety closes, a dilution cycle is initiated if the solution dilution temperature is greater than 136°F. If less than 136°F, the message “DAY – TIME – LRT – CHK SOL'N LEVEL – ABS & GEN” is displayed and the unit is prevented from starting until the **WARNING RESET** key is pressed in **SERVICE** mode with the **UNIT** switch in **STOP/RESET** position.

SUN 12:00 AM LOW REFRIGERANT TEMP – ANALOG

The unit has shut down because the refrigerant temperature, as sensed by thermistor RT10, has decreased to the shutdown threshold. The shutdown threshold is variable and determined by the relationship between the entering (ECDWT) and leaving condenser water temperature (LCDWT) and a variable defined as low absorber water temperature (LAWT) as follows:

$$\text{LAWT} = \text{ECDWT} + 0.67 (\text{LCDWT} - \text{ECDWT})$$

If LAWT is equal to or greater than 92.0°F, the analog LRT threshold is 39.0°F. If LAWT is less than or equal to 70.0°F, the LRT threshold is 35.0°F. For values of LAWT between 70.0°F and 92.0°F, the LRT threshold becomes a linear interpolation between 35.0°F and 39.0°F as follows:

$$\text{Analog LRT Cutout} = [(2 (\text{LAWT} - 70.0) / 11) + 35.0]$$

In special circumstances, it may be necessary to provide a fixed 35.0°F LRT threshold. This can be accomplished by removing program jumper J13 on the I/O expansion board.

CAUTION!!!

This jumper must never be removed by anyone other than a qualified service technician who has been counseled by the YORK factory to perform this modification. Serious unit damage can result!

The analog LRT cutout threshold that is in effect at any given time can be displayed using the **DISPLAY DATA** key.

When the refrigerant temperature increases to the reset threshold of 5°F or greater above the temperature at which it cutout (the cutout threshold is frozen at the instant of shutdown), a dilution cycle is initiated if the solution dilution temperature is greater than 136°F. If less than 136°F, “DAY – TIME – LRT – CHK SOL'N LEVEL – ABS & GEN” is displayed and the unit is prevented from starting until the **WARNING RESET** key is pressed in **SERVICE** mode with the **UNIT** switch in **STOP/RESET**. After the reset threshold is reached, the unit can be started by placing the **UNIT** switch in **STOP/**

RESET and then to **START**. (This check is not performed in **HEATING ONLY** mode.)

SUN 12:00 AM – LRT – CHK SOL'N LEVEL - ABS & GEN

(where LRT = Low Refrigerant Temperature). This message indicates the solution dilution temperature (as measured by thermistor RT11) was <136°F when the low refrigerant temperature safety device (LRT) recloses (digital shutdown) or the refrigerant temperature thermistor (RT10) rises to 44°F (analog shutdown) during a **Low Refrigerant Temp** shutdown. When this occurs, the chilled water pump is turned off.

Dilution cycles do not occur on **Low Refrigerant Temp** shutdowns until the safety device recloses (digital shutdowns) or the refrigerant temperature rises to 44°F (analog shutdowns). If the solution dilution temperature is <136°F when this occurs, a dilution cycle should not be initiated because crystallization may have already taken place during the shutdown. This message is advising the operator to check the solution level in the absorber and generator prior to starting the unit. Refer to YORK Form 155.17-NM1 for details of decrystallization.

After it has been determined that crystallization has not occurred, the unit can be restarted by placing the **UNIT** switch in the **STOP/RESET** position, then pressing the **WARNING RESET** key in **SERVICE** mode and then initiating a start.

SUN 12:00 AM CHILLED WATER FLOW SWITCH

The unit has shut down because the chilled water flow switch has opened for 2 continuous seconds while the unit was running. This check is bypassed for the first 30 seconds of "Cooling Start Sequence Initiated." To restart unit, press **UNIT** switch to **STOP/RESET** position, then to **START**.

Normal dilution cycles are not performed on **Chilled Water Flow Switch** safety shutdowns.

SUN 12:00 AM – FLS – CHK SOL'N LEVEL - ABS & GEN

(where FLS = Flow Switch). This message indicates that the solution dilution temperature (as measured by thermistor RT11) was <136°F when the chilled water flow switch (CHFLS) reclosed during a **Chilled Water Flow Switch** shutdown.

Dilution cycles are not initiated on flow switch shutdowns until the flow switch recloses during the shutdown. If the solution dilution temperature is <136°F when this occurs, a dilution cycle should not be initiated because crystallization may have taken place during the shutdown. This message is advising the operator to check the solution level in the absorber and generator prior to starting the unit. Refer to YORK Form 155.17-NM1 for details of decrystallization.

After it has been determined that crystallization has not occurred, the unit can be restarted by placing the **UNIT** switch in the **STOP/RESET** position, then pressing the **WARNING RESET** key in **SERVICE** mode and then initiating a start.

SUN 12:00 AM BURNER REM ALARM – MAN RESET

(Applies to gas/oil-fired units only). The unit is shut down because the burner control center has opened its remote alarm contacts indicating a burner control center alarm condition. Refer to Form 155.17-NM1 for details of burner control center. To restart unit, press **UNIT** switch to **STOP/RESET** position, manually reset burner control center, then press **UNIT** switch to **START** position.

Models 20G through 22G have two burner alarm contacts in series because there are two burners.

SUN 12:00 AM MANUAL BURNER PANEL MALFUNCTION

(Applies to gas/oil-fired units only.) Unit has shut down because the "Main Flame On" contacts in the burner control center (a) opened continuously for 10 seconds while the unit was running or (b) did not close within 180 seconds after the start signal is sent to the burner control center. Either of these situations could be caused by (but is not limited to) any of the following problems in the burner control center:

- a. Manual switch open
- b. Blown fuse
- c. High exhaust gas temp switch tripped

To restart unit, press **UNIT** switch to **STOP/RESET** position, then to **START** position.

Models 20G through 22G have two burner-on contacts in series because there are two burners.

SUN 12:00 AM – LD – CHK SOL'N LEVEL – ABS & GEN

(where LD = Limited Dilution). Indicates a limited dilution is called for but cannot be performed or has been interrupted because:

- the solution dilution temperature (as measured by thermistor RT11) was <136°F when a limited dilution was initiated
- or -
- the solution pump(s) overloads are tripped.

After it has been determined that crystallization has not occurred, the unit can be started. Press the **UNIT** switch to **STOP/RESET** position, then press **WARNING RESET** key in **SERVICE** mode and initiate a start. The unit cannot be started until the standby power supply contacts connected to Digital Input Board TB2-95 open.

SUN 12:00 AM – PF – CHK SOL'N LEVEL – ABS & GEN

(where PF = Power Failure). This message indicates there was a power failure while the unit was running and when power was restored, the dilute solution temperature (as measured by thermistor RT11) was <136°F.

Since a dilution cycle cannot occur during a power failure, and the dilute solution temperature has cooled to <136°F during the power failure, it is possible that crystallization has occurred during the power failure. Therefore, this message is advising the operator to check the solution level in the absorber and generator prior to restarting the unit. If any of these areas indicate a low liquid level, crystallization has possibly occurred. Refer to YORK Form 155.17-NM1 for details of crystallization and decrystallization.

After it has been determined that crystallization has not occurred, the unit can be restarted by placing the **UNIT** switch in the **STOP/RESET** position, then pressing the **WARNING RESET** key in **SERVICE** mode and then initiating a start.

SUN 12:00 AM - HIGH SOLUTION CONCENTRATION

(Applies only to units equipped with EPROM version A.01F.09 or later. Not displayed in **HEATING ONLY** mode.) The unit has shut down because the solution concentration has increased above 66.5% while the unit was running and the first stage generator temperature is at least 250.0°F. The unit will be allowed to restart when the concentration decreases to less than 66.5%. To restart unit, press **UNIT** switch to **STOP/RESET** position, then to **START** position.

The solution concentration is calculated as a function of the first stage generator temperature (RT6) and the second stage leaving refrigerant temperature (RT12). The calculated concentration can be displayed using the **1ST STAGE GEN PRESS/TEMP** key if the first stage generator temperature is at least 250.0°F, the unit is running and the concentration message display has been enabled by a qualified service technician using the "Special Setpoints and Programming Procedures" section of service manual 155.17-M2. (Concentration related messages are not displayed in **HEATING ONLY** mode.)

SUN 12:00 AM COND FLOW SWITCH

EPROM Version A.01F.07 (or earlier): If the condenser water flow switch opens while the unit is running or fails to close at unit start, a **Cycling** shutdown is initiated and the message "DAY – TIME – COND FLOW SWITCH – AUTOSTART" is displayed. A dilution is performed. If the flow switch does not reclose within 30 minutes, a **Safety** shutdown is initiated and the above message is displayed. The unit is prevented from restarting until the following reset procedure is performed. To restart the unit, press **UNIT** switch to **STOP/RESET** position. Then press **WARNING RESET** key while in **SERVICE** operating mode.

EPROM Version A.01F.08 (or later): If the condenser water flow switch opens while the unit is running, a **Cycling** shutdown is initiated, "DAY – TIME – COND FLOW SWITCH – AUTOSTART" appears, and a dilution is performed. If the flow switch closes before the dilution terminates, the unit will automatically restart. However, if the flow switch does not close before the dilution terminates, the **Cycling** shutdown becomes a **Safety** shutdown coincident with the dilution termination, all pumps are shut off, and the message "DAY – TIME – COND FLOW SWITCH" (the day and time displayed is when the cycling shutdown occurred) replaces the "DAY – TIME – COND FLOW SWITCH – AUTOSTART" message. To restart unit, move **UNIT** switch to **STOP/RESET** position, then to **START**.

WARNING MESSAGES:

Coincident with the occurrence of each of the following warning conditions, K7 relay contacts (relay output board TB4–89 & 90) close to sound an external audible alarm (supplied by others). The alarm is silenced by pressing the **WARNING RESET** key in any operating mode. After the alarm has been silenced, the warning message will be displayed until the condition that caused the alarm reaches the reset threshold and the **WARNING RESET** key is pressed in **SERVICE** mode. This clears the warning message.

If multiple warning conditions exist, the appropriate warning messages will scroll on the display while the **STATUS** key is being pressed. Each warning message will be displayed for 2 seconds and will scroll from the most recent to the oldest occurrence.

Warning messages (except purge warnings) are displayed and the alarm is activated only while the unit is running.

WARNING – LOW REFRIGERANT TEMPERATURE

Either a fixed or variable LRT warning threshold is used as determined by the position of I/O expansion board program jumper J13.

If I/O expansion board program jumper J13 is removed, the warning message is displayed and unit loading is inhibited when the refrigerant temperature decreases to 36.0°F. When the temperature increases to the reset threshold 36.5°F, the load inhibit is removed.

If I/O expansion board program jumper J13 is installed, the **Low Refrigerant Temperature** safety shutdown and warning threshold is variable, based upon the relationship of entering and leaving condenser water temperature. Refer to description of "Day-Time-Low Refrigerant Temp-Analog" message for explanation of how the LRT safety shutdown threshold is determined. The actual LRT safety threshold that is in effect at any time can be displayed using the **DISPLAY DATA** key. The warning message is displayed and the load inhibit is put in effect

when the actual refrigerant temperature is $\leq 1^{\circ}\text{F}$ above the safety shutdown threshold. The load inhibit is removed when the refrigerant temperature increases to the reset threshold of $\geq 1.5^{\circ}\text{F}$ above the safety shutdown threshold.

WARNING – HIGH GEN PRESSURE OVERRIDE

Displayed when the generator pressure increases to 659.7mm HgA (12.76 PSIA). While this condition exists, the load command is driven to minimum (30%, gas-fired units; 30% steam valve position, steam-fed units). The load command remains at minimum load until the pressure decreases to the reset value of 258.5mm HgA (5.0 PSIA). The load command will then be allowed to increase.

On steam units, a limit switch (Honeywell valves) or set-point (Leslie valves) prevents the steam valve from unloading to a position that is $<20\%$ of unit capacity. Therefore, although the steam valve is commanded to unload to 30% of full travel position, it may be prevented from actually reaching 30% steam valve position.

WARNING – HIGH GEN 1 PRESSURE OVERRIDE

or

WARNING – HIGH GEN 2 PRESSURE OVERRIDE

Gas/oil-fired models 20G through 22G have two first stage generators. A high pressure warning condition in either generator is enunciated separately. Refer to above message "Warning-High Gen Pressure Override."

WARNING – HIGH GEN TEMPERATURE OVERRIDE

Displayed when the generator temperature increases to 326°F . The load command is driven to and maintained at minimum load (30%, gas-fired units; 30% steam valve position, steam-fed units) while this condition exists. When the temperature decreases to the reset value of 250°F , the load command will be allowed to increase.

On steam units, a limit switch (Honeywell valves) or set-point (Leslie valves) prevents the steam valve from unloading to a position that is $<20\%$ of unit capacity. Therefore, although the steam valve is commanded to unload to 30% of full travel position, it may be prevented from actually reaching 30% steam valve position.

WARNING – HIGH GEN 1 TEMP OVERRIDE

or

WARNING – HIGH GEN 2 TEMP OVERRIDE

Gas/oil-fired models 20G through 22G have two first stage generators. A high temperature warning condition in either generator is enunciated separately. Refer to above message "Warning-High Gen Temperature Override."

WARNING – RET COND WATER TEMP $< 68.0^{\circ}\text{F}$

Displayed if the micro board program jumper JP6 is IN and the return condenser water temperature has been $<68.0^{\circ}\text{F}$ continuously for 30 minutes of unit operation. The reset value is 68.0°F . (This check is not performed in **HEATING ONLY** mode.)

WARNING – RET COND WATER TEMP $< 59.0^{\circ}\text{F}$

Displayed if the micro board program jumper JP6 is OUT and the return condenser water temperature has been $<59.0^{\circ}\text{F}$ continuously for 30 minutes of unit operation. The reset value is 59.0°F . (This check is not performed in **HEATING ONLY** mode.)

WARNING – PURGE PUMP OVERLOADS OPEN

Displayed when the purge pump (M3) motor protector (3OL) or motor thermal switch (MTH3) has opened. If the motor protector has opened, it requires a manual reset. The thermal switch automatically recloses.

WARNING – PURGE TRANSDUCER ERROR

Displayed when either the purge tank transducer (PT4) or purge pump transducer (PT3) is indicating an out-of-range pressure low ($\leq 0.0\text{mm HgA}$) continuously for 25 seconds. This message is displayed only if the unit is equipped with the optional auto purge system. The reset threshold is any in-range value.

WARNING – FAULTY SOL'N DIL'N TEMP SENSOR

Displayed when the solution dilution temperature thermistor RT11 indicates a temperature equal to or less than 91°F continuously for 1 minute. This check is bypassed for the first 30 minutes of unit run time. The reset threshold is any value greater than 91°F . (This check is not performed in **HEATING ONLY** mode.)

WARNING – ENT COND WATER TEMP HIGH LIMIT

Displayed when the entering condenser water temperature exceeds the programmed value for 10 continuous minutes following a 30-minute bypass at start. While this condition exists, the load command is limited to 60%. The reset value of 0.1°F below the programmed value. (This check is not performed in **HEATING ONLY** mode.)

Instructions for programming the threshold are in the service manual, Form 155.17-M2, under "Special Programming Features." This value is programmed at the YORK factory. It should not be arbitrarily changed. (This check is not performed in **HEATING ONLY** mode.)

REPLACE RTC, U 16 – REPROGRAM SETPOINTS

Indicates that the battery located inside the **REAL-TIME CLOCK IC** Chip (U16 on the micro board) is defective. This battery provides back-up power to the RTC memory (RAM) in the event of a utility AC power failure. This assures that system setpoints will be maintained. If this message appears, the RTC IC Chip (U16) on the micro board must be replaced. If there is a power failure while this message is displayed, the setpoints will be lost and must be reprogrammed.

WARNING – AUTO PURGE FAILURE

(Applies only to units equipped with Automatic Purge Hardware (see Note 1 below) and EPROM version A.01F.09 or later.) The I/O expansion board program jumper JP1 must be removed (**AUTO PURGE HARDWARE** selected) and **AUTO TANK PURGE OPERATION** selected at the keypad. During normal automatic purge operation, the purge tank pressure (PT4) must increase to 60mm HgA to initiate the purge operation by turning on the purge pump. When the purge pump pressure (PT3) has decreased to 15mm HgA, a 1-minute timer is started. If, during this 1-minute period, the purge tank pressure (PT4) has not decreased, this message is displayed and the purge tank solenoid valve (1 SOL) and pump solenoid valve (2 SOL) are closed, the purge pump is turned off and the programmed “Auto Tank Purge” operation defaults to “Manual Purge” operation. This 1-minute period is re-initialized at each timeout and this pressure check is performed for the duration of the purge operation. Refer to “Special Setpoints and Programming Procedures” section of service manual Form 155.17-M2 for details of programming “Auto Tank Purge Operation.”

WARNING – PRG PMP FAIL; MAN CLOSE VP2, VP5

(Applies only to units equipped with Automatic Purge Hardware (see Note 1 below) and EPROM version A.01F.09 or later.) The I/O expansion board program jumper JP1 must be removed (**AUTO PURGE HARDWARE** selected) and **AUTO TANK PURGE OPERATION** selected at the keypad. Anytime the purge pump solenoid valve (2SOL) has been energized for at least 1 minute during an “Auto Tank Purge” and the purge pump pressure (PT3) increases to greater than 100mm HgA for at least 1 second, this message is displayed, the purge tank (1 SOL) and pump (2 SOL) solenoid valves are de-energized (closed), the purge pump is turned off after a 65-second delay to allow the purge pump solenoid valve to fully close, and the programmed “Auto Tank Purge” operation defaults to “Manual Purge” operation. This is indicative of a purge pump failure. The operator should manually close valves VP2 and VP5. The reset threshold is any pressure less than 100mm HgA. Refer to “Special Setpoints and Programming Procedures”

section of service manual Form 155.17-M2 for details of programming “Auto Tank Purge Operation.”

WARNING – 2 SOL FAIL; MANUAL CLOSE VP2, VP5

(Applies only to units equipped with Automatic Purge Hardware (see Note 1 below) and EPROM version A.01F.09 or later.) The I/O expansion board program jumper JP1 must be removed (**AUTO PURGE HARDWARE** selected) and **AUTO TANK PURGE OPERATION** selected at the keypad. Anytime the purge pump is **not** running, and the purge pump pressure (PT3) increases to greater than 100mm HgA for at least 1 second, this message is displayed, the purge tank (1 SOL) and pump (2 SOL) solenoid valves are de-energized (closed), the purge pump is turned on, and the programmed “Auto Tank Purge” operation defaults to “Manual Purge” operation. This is indicative of a purge pump solenoid (2 SOL) valve failure. The operator should manually close valves VP2 and VP5. The reset threshold for this message is any pressure less than 100mm HgA. Manual turnoff of the purge pump is prevented during the 65-second pump turnoff delay. If this is attempted before the 65 seconds have elapsed, the message “PURGE PUMP VALVE CLOSING” is displayed when the **PUMP STATUS** key is pressed. The purge pump continues to run until manually turned off using the following procedure:

1. Press **PUMP STATUS** key. This message is displayed:

CLOSE VP2, VP5; PRESS ‘MANUAL PUMP’ KEY

2. Operator should close VP2 and VP5.
3. Press **MANUAL PUMP** key. The purge pump turns off and this message is displayed:

PURGE PUMP – OFF – MANUAL PURGE

4. Press **DISPLAY HOLD** key. The normal foreground message is displayed.

Refer to “Special Setpoints and Programming Procedures” section of service manual Form 155.17-M2 for details of programming “Auto Tank Purge Operation.”

WARNING – EXCESS PURGE

(Applies only to units equipped with Automatic Purge Hardware (see Note 1 below) and EPROM version A.01F.09 or later.) The I/O expansion board program jumper JP1 must be removed (**AUTO PURGE HARDWARE** selected) and **AUTO TANK PURGE OPERATION** selected at the keypad. Anytime the unit is operating in the “Auto Tank Purge” mode, and 6 or more automatic purges occur in the last 7 days, this message is displayed. The excess purge warning check is disabled

during the first 150 operating hours because more frequent purging of newly commissioned unit is common, especially if the unit was shipped with a nitrogen charge.

WARNING – SOL'N CONCENTRATION OVERRIDE

(Applies only to units equipped with EPROM version A.01F.09 or later. Not displayed in **HEATING ONLY** mode.) Displayed when the unit is running and the first stage generator temp is at least 250.0°F and the solution concentration exceeds 66.0%. The load command is driven to and maintained at minimum load. When the concentration decreases to 65.0% or less, the load limit is released and the message can be reset. The solution concentration is calculated as a function of the first stage generator temperature (RT6) and the second stage leaving refrigerant temperature (RT12).

The calculated concentration can be displayed using the **1ST STAGE GEN PRESS/TEMP** key if the first stage generator temperature is at least 250.0°F, the unit is running, and concentration message display has been enabled by a qualified service technician using the "Special Setpoints and Programming Procedures" in service manual 155.17-M2. (Concentration related messages are not displayed in **HEATING ONLY** mode.)

¹ Automatic Purge Hardware consists of:

- PT3 - Purge Pump Pressure Transducer
- PT4 - Purge Tank Pressure Transducer
- 1 SOL - Purge Tank Solenoid Valve, and
- 2 SOL - Purge Pump Solenoid Valve



P.O. Box 1592, York, Pennsylvania USA 17405-1592
Copyright © by York International Corporation 1997
FORM 155.17-02 (1296)
SUPERSEDES: 155.17-02 (1292)

Subject to change without notice. Printed in USA
ALL RIGHTS RESERVED
FAH 3M 297 10.06
CODES: ABS, 2SAM