



VFD68 Variable Frequency Drives (230 or 460 VAC)

Installation Instructions

VFD68Bxx, VFD68Cxx

Part No. 24-7664-3108, Rev. D
Software Release April 2016

Refer to the [QuickLIT website](#) for the most up-to-date version of this document.

Introduction	3
North American Emissions Compliance	3
United States	3
Canada	3
Agency Standards Compliance	4
Installation	4
Checking the Rating Plate	4
Selecting a Motor	5
Selecting a VFD68 Drive for Controlling Multiple Motors	5
Location Considerations	5
Dimensions	8
Mounting	9
Wiring	11
Precautions	12
Terminal Screw Torque Specifications	13
Branch Circuit Protection	13
Short Circuit Ratings	14
High-Voltage Wire Size and Maximum Wire Length	15
Selecting the Correct VFD68 Drive for a Fan Motor	15
Calculating the Maximum Wire Length	16
Making High-Voltage Wiring Connections	18
Making Low-Voltage Wiring Connections	20
Input Wiring Connections	22
Setup and Adjustment	26
Correspondences Between Digital and Actual Characters	26

Operation Modes	26
RUN, MON, PRM LEDs	27
VFD68Bxx and VFD68Cxx Drive Basic and Advanced Parameters	28
Frequency and Motor Speed	31
Parameter Settings Calculations for Motor Speed vs. Pressure	32
PWM Frequency, Audible Motor Noise, and EMI	34
Adjusting the Default Parameters	34
Enter the Parameter Adjustment Mode	34
Select and Change Most Parameters	34
Select and Change C-Prefix Parameters	35
Exit the Parameter Adjustment Mode	35
Configuring Manual Motor Speed Control in PU Mode	35
Configuring EXT Mode Using Analog Inputs	36
Troubleshooting	36
Resetting the VFD68 Drive	39
Reset Option 1	39
Reset Option 2	39
Manually Stopping the Motor	39
Restarting the Motor After It Has Stopped	39
Technical Specifications	40
VFD68Bxx or VFD68Cxx Variable Frequency Drive (230 or 460 VAC)	40

VFD68 Variable Frequency Drives (230 or 460 VAC)

Introduction

The VFD68 Variable Frequency Drives are designed to provide three-phase motor speed control in a variety of HVACR applications. The VFD68 Drives are factory-configured for condenser fan speed control on HVACR condensing units. You can quickly and easily reconfigure the VFD68 Drives to control variable speed pumps in cooling and heating applications, or to drive variable speed supply fans in VAV applications.

This document provides information for VFD68Bxx (230 VAC) and VFD68Cxx (460 VAC) Drive models only. For information pertaining to VFD68Dxx (575 VAC) Drive models, refer to the *VFD68 Variable Frequency Drive (575 VAC) Installation Instructions (Part No. 24-7664-3116)*.

Note: The VFD68 Drive cannot drive motors in conveyor systems or robotic applications.

IMPORTANT: Use this VFD68 Variable Frequency Drive only as an operating control. Where failure or malfunction of the VFD68 Drive could lead to personal injury or property damage to the controlled equipment or other property, additional precautions must be designed into the control system. Incorporate and maintain other devices, such as supervisory or alarm systems or safety or limit controls, intended to warn of or protect against failure or malfunction of the VFD68 Drive.

IMPORTANT : Utiliser ce VFD68 Variable Frequency Drive uniquement en tant que dispositif de régulation. Lorsqu'une défaillance ou un dysfonctionnement du VFD68 Drive risque de provoquer des blessures ou d'endommager l'équipement contrôlé ou un autre équipement, la conception du système de contrôle doit intégrer des dispositifs de protection supplémentaires. Veiller dans ce cas à intégrer de façon permanente d'autres dispositifs, tels que des systèmes de supervision ou d'alarme, ou des dispositifs de sécurité ou de limitation, ayant une fonction d'avertissement ou de protection en cas de défaillance ou de dysfonctionnement du VFD68 Drive.

Note: Do not attempt to install, operate, maintain, or inspect the VFD68 Drive until you have read through this document carefully and can use the equipment correctly. Do not use this product until you fully understand the equipment, safety information, and instructions.

To view the *VFD68 Variable Frequency Drive Technical Bulletin (Part No. 24-7664-3051)*, which covers 230 VAC, 460 VAC, and 575 VAC models, visit the following web address:

http://cgproducts.johnsoncontrols.com/MET_PDF/2476643051.pdf

North American Emissions Compliance

United States

This equipment has been tested and found to comply with the limits for a Class A digital device pursuant to Part 15 of the FCC Rules. These limits are designed to provide reasonable protection against harmful interference when this equipment is operated in a commercial environment. This equipment generates, uses, and can radiate radio frequency energy and, if not installed and used in accordance with the instruction manual, may cause harmful interference to radio communications. Operation of this equipment in a residential area may cause harmful interference, in which case users will be required to correct the interference at their own expense.

Canada

This Class (A) digital apparatus meets all the requirements of the Canadian Interference-Causing Equipment Regulations.

Cet appareil numérique de la Classe (A) respecte toutes les exigences du Règlement sur le matériel brouilleur du Canada.

Agency Standards Compliance

- North America: cULus Listed; UL 508C, USA File: NMMS.E244421; Canada File: NMMS7.E244421
- Europe: CE Mark - Conforms to the provisions of the Low Voltage Directive and the EMC Directive when an EMC-compliant line filter is attached to the power supply.¹
- Australia: Regulatory Compliance Mark (RCM)

Installation

Checking the Rating Plate

Before you install the VFD, check the rating plate on the side to verify that the voltage, kW (horsepower), and output current ratings are correct for your application. See Figure 1, Table 1, and [Selecting the Correct VFD68 Drive for a Fan Motor](#) on page 15.

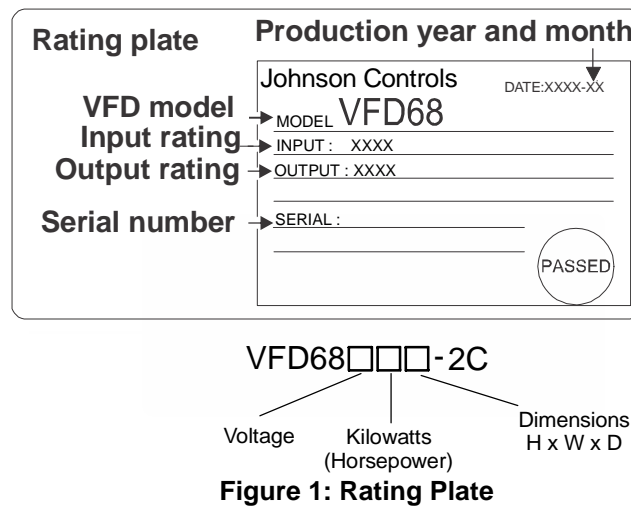

Figure 1: Rating Plate

Table 1: VFD68 Drive Model Information

	Voltage	kW (Horsepower)	Dimensions, H x W x D, mm (in.)
B	200–240 VAC, 50/60 Hz	0.1 (1/8)	128 x 68 x 81 (5 x 2-11/16 x 3-3/16)
C	400–480 VAC, 50/60 Hz	0.2 (1/4)	128 x 68 x 113 (5 x 2-11/16 x 4-7/16)
D		0.4 (1/2)	128 x 68 x 133 (5x 2-11/16 x 5-1/4)
F		0.75 (1)	128 x 108 x 130 (5 x 4-1/4 x 5-1/8)
G		1.5 (2)	128 x 108 x 136 (5 x 4-1/4 x 5-5/16)
H		2.2 (3)	128 x 108 x 156 (5 x 4-1/4 x 6-1/8)
J		3.7 (5)	128 x 108 x 166 (5 x 4-1/4 x 6-1/2)
K		5.5 (7-1/2)	128 x 170 x 142 (5 x 6-11/16 x 5-5/8)
L		7.5 (10)	150 x 220 x 155 (5-15/16 x 8-11/16 x 6-1/8)
M		11 (15)	150 x 140 x 136 (5-15/16 x 5-1/2 x 5-5/16)
N		15 (20)	150 x 220 x 148 (5-15/16 x 8-11/16 x 5-13/16)
P			260 x 220 x 190 (10-1/4 x 8-11/16 x 7-1/2)

1. For more information, see *Appendix 5: EMC Line Filter Selection Chart* in the *VFD68 Variable Frequency Drive Technical Bulletin (Part No. 24-7664-3051)*.

For example, a VFD68BGG would be rated for 200–240 VAC and 2 horsepower.

IMPORTANT: Frequently starting and stopping the VFD shortens the lifespan of the VFD68 Drive. In applications where the drive will start or stop frequently, select a VFD which has an output current rating that is 1.5 to 2 times greater than the FLA current rating of the three-phase motor.

Selecting a Motor

IMPORTANT: When selecting the motor, do not exceed the maximum output current rating of the VFD68 Drive.

Motors used with the VFD68Bxx or VFD68Cxx Drive must:

- be AC induction three-phase motors that are UL Recognized and CSA Certified, or equivalent
- be rated for: 230 VAC at 50/60 Hz; or 460 VAC at 50/60 Hz
- have an Inverter Rating (460 VAC motors)
- have Insulation Class F or better

The VFD68 Drive is intended for use with variable speed motors that are rated for 40:1 operation.

Note: If three-phase power is not available as supply power for the VFD68 Drive, refer to the *VFD68 Variable Frequency Drive Technical Bulletin (Part No. 24-7664-3051)*.

Selecting a VFD68 Drive for Controlling Multiple Motors

IMPORTANT: Do not control both single-phase and three-phase motors with the same VFD68 Drive.

A VFD68 Drive can control multiple motors wired in parallel; however, the sum of the Full Load Amperes (FLA) ratings for the motors must not exceed the maximum output current rating of the VFD68 drive, including any de-rating due to altitude. See Table 2 on page 6 for derating information.

Location Considerations



WARNING: Risk of Fire or Electric Shock.

Install the device in an environment relatively free of contaminants such as dust, condensation, or chemical agents. A dirty or damp environment may cause an electric arc across contaminated terminals.

AVERTISSEMENT: Risque de décharge électrique ou incendie.

Installer l'appareil dans un environnement présentant une quantité réduite de contaminants tels que de la poussière, de la condensation ou des agents chimiques. Un environnement pollué ou humide risque d'entraîner la formation d'un arc électrique entre des bornes contaminées.



CAUTION: Risk of Property Damage.

The VFD68 Drive can generate and dissipate significant heat. Mount the VFD68 Drive on a metal, concrete, or cinder block mounting surface. Mounting the VFD68 Drive on surfaces made of wood or other heat-sensitive material may result in damage to the mounting surface.

MISE EN GARDE: Risque de dégâts matériels.

Le VFD68 Drive peut générer et émettre une chaleur importante. Installer le VFD68 Drive sur une surface de montage en métal, en béton ou en parpaings. L'installation du VFD68 Drive sur une surface en bois ou composée de matériaux sensibles à la chaleur risque d'endommager la surface de montage.

Observe the following location guidelines:

- Ensure that the mounting surface can support the drive, mounting hardware, and any user-supplied panel or enclosure.
- Mount drives on flat, even surfaces.
- Allow sufficient space for wires and connections.
- Do not mount the modules on surfaces that are prone to vibration or in locations where radio frequency or electromagnetic emissions may cause interference.
- Do not install the modules in airtight enclosures.
- Do not install heat-generating devices that may cause the temperature to exceed the ambient operating limit in the same enclosure as the modules.

The VFD68 Drive has been approved for use in an enclosure. Approval tests were conducted under the conditions in Table 2.

When mounting the VFD68 Drive in an enclosure, ensure that the specified space around the drive is maintained, and that the ambient conditions are within the specified limits.

IMPORTANT: The VFD68 Drive is intended to be mounted in an enclosure that only allows access by trained and authorized personnel, and that prevents the ingress of contamination. It is designed for use in an environment classified as pollution degree 2 in accordance with IEC 60664-1. This means that only dry, non-conducting contamination is acceptable.

Table 2: Environmental Considerations

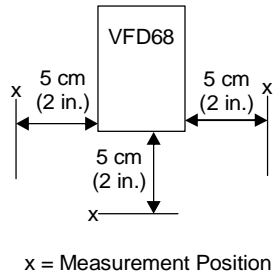
Surrounding Air Temperature¹	-40 to 50°C (-40 to 122°F) as measured 5 cm from the VFD	 <p style="font-size: small;">x = Measurement Position</p> <p style="font-size: x-small;">FIGtemp_10c_dfig</p>
Ambient Humidity	90% RH or less (Non-condensing)	
Storage Temperature	-40 to 65°C (-40 to 149°F)	
Atmosphere	Indoors (no corrosive and flammable gases, oil mist, dust and dirt.)	
	Altitude Limit ² : Below 1,000 m (3,280 ft) above sea level	
	Vibration Limit: 5.9 m/s ² (19.4 ft/s ²) or less at 10–55 Hz (directions of x, y, z axes)	

1. Surrounding air temperature is a temperature measured at a measurement position in an enclosure. Ambient air temperature is a temperature outside an enclosure. The VFD68 is designed to operate above 50°C by following the maximum output current derating limits show in Table 3 and Table 4 and Figure 2.
2. Altitude limit given is for standard operation of the VFD. For operation at higher altitudes, derate by 3% for each 500 m (1,640.4 ft), up to a maximum of 2,500 m (8,202 ft) (91% derating).

Table 3: Maximum Current Output Derating above 50°C by VFD68Bxx Drive Model

VFD68Bxx Models	Rated Capacity kW (HP)	Maximum Output Current at 50° (Amperes)	Maximum Output Current at 60° (Amperes)	Maximum Output Current at 70° (Amperes)
VFD68BBB	0.1 (1/8)	0.8	0.6	0.5
VFD68BCB	0.2 (1/4)	1.4	1.1	0.9
VFD68BDC	0.4 (1/2)	2.5	2.1	1.7
VFD68BFD	0.75 (1)	4.2	3.5	2.9
VFD68BGG	1.5 (2)	7.0	5.9	4.9
VFD68BHG	2.2 (3)	10.0	8.5	7.0
VFD68BJK	3.7 (5)	16.5	14.0	11.5
VFD68BKL	5.5 (7-1/2)	23.8	20.2	16.6
VFD68BLL	7.5 (10)	31.8	27.0	22.2
VFD68BMP	11 (15)	45.0	38.2	31.5
VFD68BNP	15 (20)	58.0	49.3	40.6

Table 4: Maximum Current Output Derating above 50°C by VFD68Cxx Drive Model

VFD68Bxx Models	Rated Capacity kW (HP)	Maximum Output Current at 50° (Amperes)	Maximum Output Current at 60° (Amperes)	Maximum Output Current at 70° (Amperes)
VFD68CDF	0.4 (1/2)	1.2	1.0	0.8
VFD68CFF	0.75 (1)	2.2	1.8	1.5
VFD68CGG	1.5 (2)	3.6	3.0	2.5
VFD68CHH	2.2 (3)	5.0	4.2	3.5
VFD68CJJ	3.7 (5)	8.0	6.8	5.6
VFD68CKL	5.5 (7-1/2)	12.0	10.2	8.4
VFD68CLL	7.5 (10)	16.0	13.6	11.2
VFD68CMP	11 (15)	23.0	19.6	16.1
VFD68CNP	15 (20)	29.5	25.0	20.6

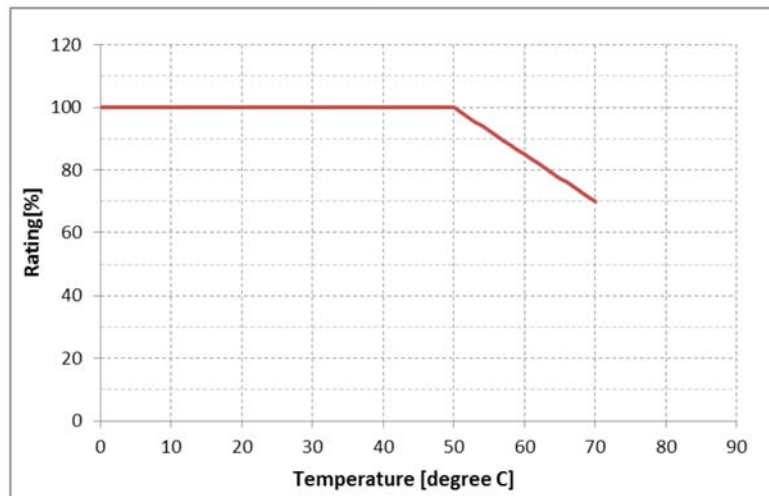

Figure 2: VFD68Bxx and VFD68Cxx Maximum Current Output Derating above 50°C

Dimensions

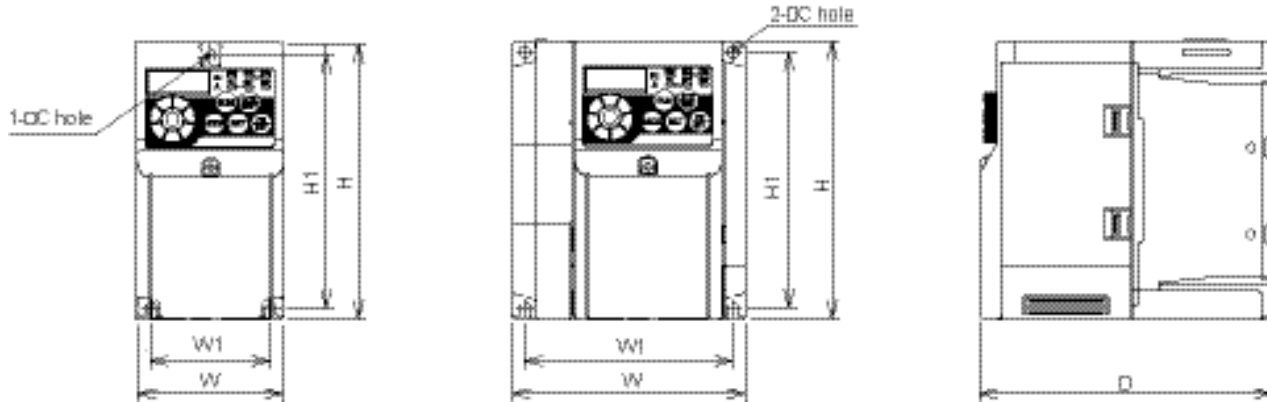

Figure 3: Dimensions for VFD68 Drives, 230–460 VAC Models

Table 5: Three-Phase 230 VAC Models, mm (in.)

VFD Model	H	H1	W	W1	D
VFD68BBB	128 (5.04)	118 (4.65)	68 (2.68)	56 (2.20)	80.5 (3.17)
VFD68BCB					112.5 (4.43)
VFD68BDC					132.5 (5.22)
VFD68BFD					135.5 (5.34)
VFD68BGG	150 (5.91)	138 (5.43)	108 (4.25)	96 (3.78)	142.5 (5.61)
VFD68BHG					155 (6.10)
VFD68BJK					155 (6.10)
VFD68BKL	260 (10.23)	244 (9.61)	220 (8.66)	208 (8.19)	190 (7.48)
VFD68BLL					190 (7.48)
VFD68BMP	260 (10.23)	244 (9.61)	220 (8.66)	195 (7.68)	190 (7.48)
VFD68BNP					190 (7.48)

Table 6: Three-Phase 460 VAC Models, mm (in.)

VFD Model	H	H1	W	W1	D
VFD68CDF	128 (5.04)	118 (4.65)	108 (4.25)	96 (3.78)	129.5 (5.10)
VFD68CFF					135.5 (5.34)
VFD68CGG					155.5 (6.12)
VFD68CHH					165.5 (6.52)
VFD68CJJ	150 (5.91)	138 (5.43)	220 (8.66)	208 (8.19)	155 (6.10)
VFD68CKL					155 (6.10)
VFD68CLL					155 (6.10)
VFD68CMP	260 (10.23)	244 (9.61)	220 (8.66)	195 (7.68)	190 (7.48)
VFD68CNP					190 (7.48)

Mounting

1. Loosen the screws on the front cover and remove the cover (Figure 4).

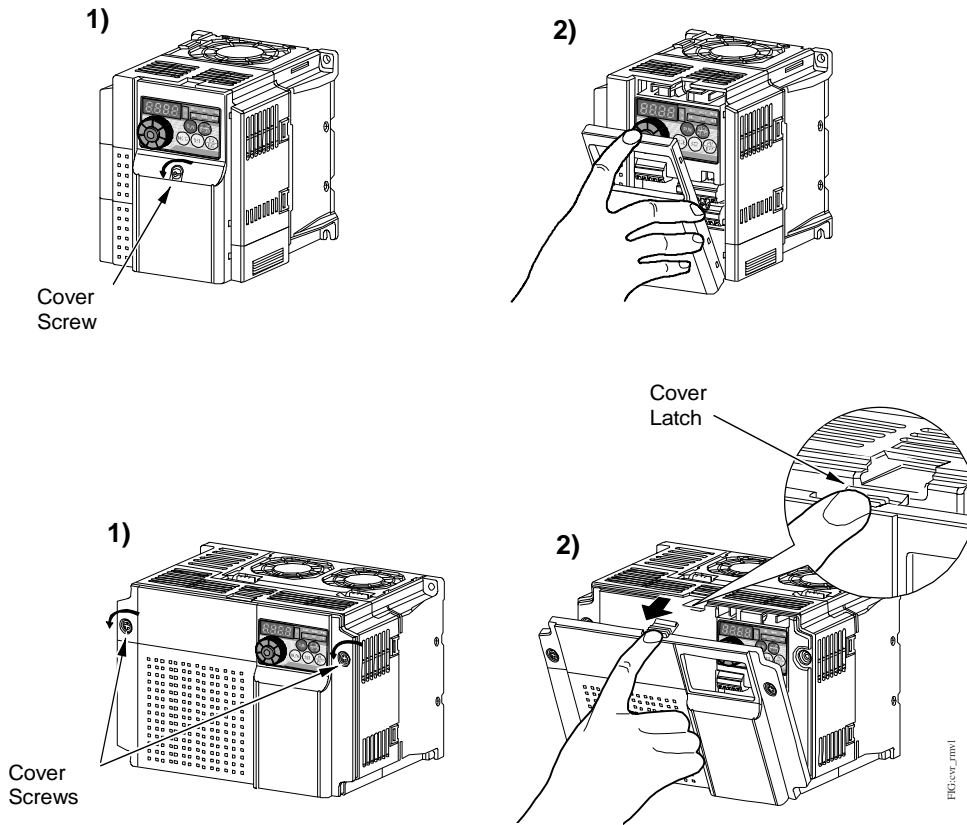

Figure 4: Loosen the Cover Screws and Remove the Front Cover

2. Remove the high-voltage wiring cover at the bottom of the VFD68 Drive (Figure 5).

! Warning: Risk of Electric Shock

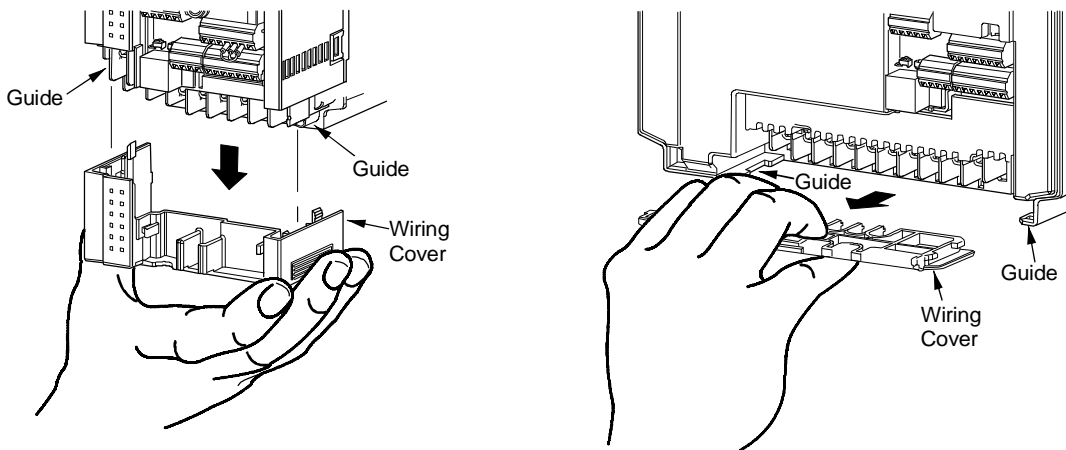

Figure 5: Remove the High-Voltage Wiring Cover

Mount the VFD vertically (Figure 6) in an acceptable NEMA-rated enclosure on a non-flammable surface. When you drill mounting holes and mount the VFD, ensure that you do not allow metal chips or other material to enter the VFD housing.

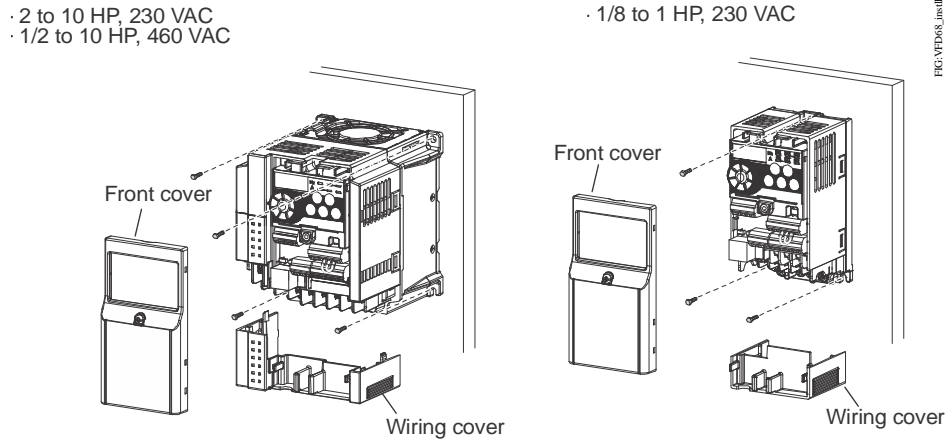

Figure 6: Mounting the VFD68 Drive

See Figure 7 and Table 7 for mounting space requirements.

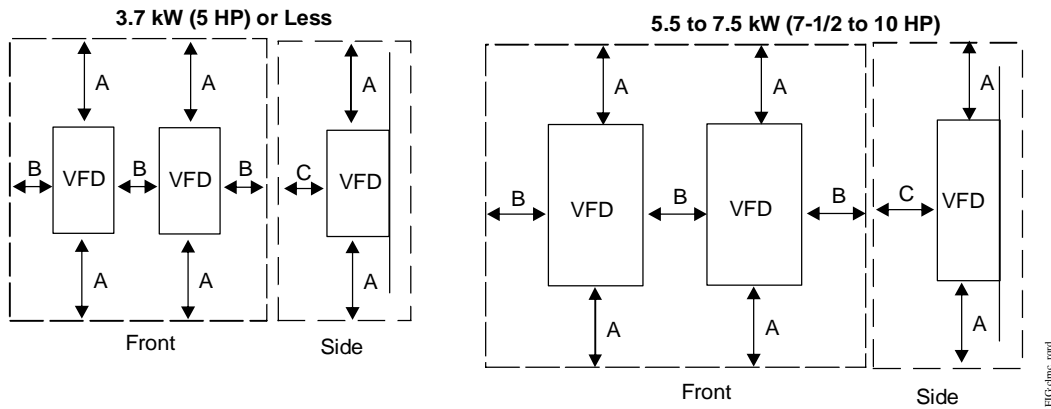

Figure 7: Required Clearance for Mounting Inside an Enclosure

Table 7: Required Clearance

Dimension	3.7 kW (5 HP) or Less	5.5–7.5 kW (7-1/2 to 10 HP)
A	100 mm (4 in.) or more	100 mm (4 in.) or more
B	10 mm (7/16 in.) or more	50 mm (2 in.) or more
C		

Wiring



WARNING: Risk of Electric Shock.

Disconnect the power supply before making electrical connections. Contact with components carrying hazardous voltage can cause electric shock and may result in severe personal injury or death.

AVERTISSEMENT: Risque de décharge électrique.

Débrancher l'alimentation avant de réaliser tout branchement électrique. Tout contact avec des composants porteurs de tensions dangereuses risque d'entraîner une décharge électrique et de provoquer des blessures graves, voire mortelles.



WARNING: Risk of Electric Shock.

Do not touch any exposed metal parts with anything other than properly insulated tools or insulated probes of the digital voltage meter. Failure to use properly insulated tools and probes may result in severe personal injury or death.

AVERTISSEMENT: Risque de décharge électrique.

Ne jamais toucher une partie métallique exposée avec tout élément autre que des outils correctement isolés ou les sondes isolées du voltmètre numérique. L'utilisation d'outils et de sondes incorrectement isolés risque de provoquer des blessures graves, voire mortelles.



WARNING: Risk of Electric Shock.

To avoid possible electric shock, wait at least 10 minutes after the AC supply power has been disconnected from the VFD68 Drive before servicing the device. The VFD68 Drive remains electrically charged for a period of time after power is removed. Failure to wait until the VFD68 Drive fully discharges could cause electric shock, personal injury, or death.

AVERTISSEMENT: Risque de décharge électrique.

Afin d'éviter tout risque de décharge électrique, attendre au moins 10 minutes après la déconnexion de l'alimentation CA du VFD68 Drive pour intervenir sur l'appareil. Le VFD68 Drive reste chargé électriquement pendant un certain temps après la coupure de son alimentation. Le non-respect du délai de décharge électrique complète du VFD68 Drive peut entraîner une décharge électrique provoquant des blessures graves, voire mortelles.



CAUTION: Risk of Property Damage.

Do not apply power to the system before checking all wiring connections. Short circuited or improperly connected wires may result in permanent damage to the equipment.

MISE EN GARDE: Risque de dégâts matériels.

Ne pas mettre le système sous tension avant d'avoir vérifié tous les raccords de câblage. Des fils formant un court-circuit ou connectés de façon incorrecte risquent d'endommager irrémédiablement l'équipement.



CAUTION: Risk of Property Damage.

Do not run low-voltage cable in the same conduit or wiring troughs with high-voltage wires. Running low- and high-voltage wires in the same conduit or wiring troughs may damage the equipment or cause system malfunction.

MISE EN GARDE: Risque de dégâts matériels.

Ne pas faire courir un câble basse tension dans les mêmes gaines ou goulottes électriques que des câbles haute tension. L'installation de fils basse tension et haute tension dans les mêmes gaines ou goulottes électriques risque d'endommager l'équipement ou de provoquer des dysfonctionnements du système.

IMPORTANT: Use copper conductors only. Make all wiring in accordance with local, national, and regional regulations.

IMPORTANT: Do not exceed the VFD68 Drive electrical ratings. Exceeding the Drive electrical ratings can result in permanent damage to the drive and void any warranty.

IMPORTANT: Run all low-voltage wiring and cables separate from all high-voltage wiring. Shielded cable is strongly recommended for input (sensor) and analog output cables that are exposed to high electromagnetic or radio frequency noise.

IMPORTANT: Electrostatic discharge can damage VFD68 Drives. Use proper electrostatic discharge (ESD) precautions during installation and servicing to avoid damaging VFD68 Drives.

IMPORTANT: Do not connect supply power to the VFD68 Drive before finishing wiring and checking all wiring connections. Short circuits or improperly connected wires can result in damage to the drive and void any warranty.

Precautions

Before you apply power to the VFD68 Drive and controlled motor, always recheck the following items:

- Connect the VFD only to three-phase induction motors. Connecting the VFD to other electrical equipment may cause damage.
- Application of power to the output terminals (U, V, W) of the VFD will damage the VFD. Never connect supply power to the drive output terminals.
- If you wire multiple motors to the VFD output, run separate wires to each motor. Do not use daisy-chain wiring.
- Do not install a power factor correction capacitor, surge suppressor, or capacitor type filter on the VFD output side. These devices can cause the VFD to trip, or they can damage the capacitor and surge suppressor.
- A high-voltage charge remains in the VFD electronic components for a short time after the power is switched off.

Wait at least 10 minutes after the power supply has been switched off to allow the electric charge and heat to dissipate. Using a voltmeter, make sure that the voltage across the main circuit terminals P/+ and N/- of the VFD is no more than 30 VDC.

- A short circuit or earth (ground) fault on the VFD output side can damage the VFD.
 - Check the insulation resistance of the circuit before you operate the VFD; repeated short circuits may damage the VFD. These short circuits may be caused by peripheral circuit inadequacy, an earth (ground) fault due to wiring inadequacy, or reduced motor insulation resistance.
 - Check the ground (to-earth) insulation and phase-to-phase insulation of the VFD output side before applying power.

Carefully check the motor insulation resistance, especially when the VFD is used with an old motor or a motor located in unfavorable conditions.

- Do not exceed the permissible voltage to the VFD I/O signal circuits.

Application of a voltage higher than the permissible voltage to the VFD I/O signal circuits, or applying voltage of opposite polarity, may damage the I/O devices.
- Do not short circuit the +VDC excitation voltage outputs (terminals 10 and PC) to common (terminals: 5 and SD). Shorting the excitation voltage outputs to common may damage the VFD.

- Prevent VFD-generated EMI from causing functional problems.
 - Do not run the low-voltage signal cables and the high-voltage power cables in parallel with each other, and do not bundle them together.
 - Run low-voltage signal cables as far away as possible from high-voltage power cables.
 - Use shielded cables for the low-voltage signal cables. Connect the sensor cable shield at only one point and that one point is the same terminal as the sensor's common wire.
 - Install a ferrite core on the signal cable (for example, ZCAT3035-1330 TDK).

Terminal Screw Torque Specifications

Tighten the terminal screw to the specified torque. Over-tightening the terminal screws may damage the terminal blocks and screw threads. Loose terminal screw connections can result in a short circuit or malfunction.

Table 8: Torque Specifications for VFD66Bxx Drives

Rated Capacity, kW (HP)	Terminal Screw Size¹	Tightening Torque, N•m (lb•in.)
0.1–0.75 (1/8–1)	M3.5	1.2 (10.6)
1.5–3.7 (2–5)	M4	1.5 (13.3)
5.5–11 (7.5–15)	M5	2.5 (22.2)
15 (20)	M6 (M5)	4.4 (39)

1. The terminal screw size indicates the terminal size for R/L1, S/L2, T/L3, U, V, W, PR, P/+, N/-, P1, and earthing (grounding). The terminal screw size for earthing (grounding) appears in parenthesis if it is a different size.

Table 9: Torque Specifications for VFD68Cxx Drives

Rated Capacity, kW (HP)	Terminal Screw Size¹	Tightening Torque, N•m (lb•in.)
0.4–11 (1/2–15)	M4	1.5 (13.3)
15 (20)	M5	2.5 (22)

1. The terminal screw size indicates the terminal size for R/L1, S/L2, T/L3, U, V, W, PR, P/+, N/-, P1, and earthing (grounding). The terminal screw size for earthing (grounding) appears in parenthesis if it is a different size.

Branch Circuit Protection

Integral solid-state short circuit protection does not provide branch circuit protection. The installer must provide branch circuit protection in accordance with the National Electrical Code for the U.S. or the Canadian Electrical Code for Canada and any additional codes.

As specified, UL Class T fuses or any faster acting fuse with the appropriate rating or Listed UL 489 Molded Case Circuit Breaker (MCCB) must be employed in accordance with Table 10 on page 14 and Table 11 on page 14.

Table 10: VFD68Bxx Drives Electrical Ratings

230 VAC	kW (HP)										
	0.1 (1/8)	0.2 (1/4)	0.4 (1/2)	0.75 (1)	1.5 (2)	2.2 (3)	3.7 (5)	5.5 (7.5)	7.5 (10)	11 (15)	15 (20)
Rated fuse voltage (V)	240 V or more										
Fuse maximum allowable rating (A) (without power factor improving reactor) ¹	15	15	15	20	30	40	60	70	80	150	175
Molded case circuit breaker (MCCB) Maximum allowable rating (A) ¹	15	15	15	15	20	25	40	60	80	110	150

1. Maximum allowable rating by US National Electrical Code. Exact size must be chosen for each installation.

Table 11: VFD68Cxx Electrical Ratings

460 VAC	kW (HP)									
	0.4 (1/2)	0.75 (1)	1.5 (2)	2.2 (3)	3.7 (5)	5.5 (7.5)	7.5 (10)	11 (15)	15 (20)	
Rated fuse voltage (V)	480 V or more									
Fuse maximum allowable rating (A) (without power factor improving reactor) ¹	6	10	15	20	30	40	70	80	90	
Molded case circuit breaker (MCCB) Maximum allowable rating (A) ¹	15	15	15	15	20	30	40	50	70	

1. Maximum allowable rating by US National Electrical Code. Exact size must be chosen for each installation.

Short Circuit Ratings

The VFD68 Drives meet the requirements for their respective rating categories (Table 12).

Table 12: VFD68 Drives Short Circuit Ratings

Rating Category	Suitable for use in a circuit capable of delivering not more than
VFD68Bxx Drives (230 VAC Class)	100 kA rms symmetrical amperes, 264 V maximum
VFD68Cxx Drives (460 VAC Class)	100 kA rms symmetrical amperes, 528 V maximum

High-Voltage Wire Size and Maximum Wire Length

IMPORTANT: Use copper conductors only. Make all wiring in accordance with local, national, and regional regulations.

Use UL Listed copper, stranded wire with insulation rated at 75°C (167°F) for wiring the high-voltage supply to the drive (R/L1, S/L2, T/L3) and wiring the high-voltage drive output (U, V, W) to the motor.

Selecting the Correct VFD68 Drive for a Fan Motor

1. Determine the maximum current consumption from the motor ratings label.
2. Select the appropriate table for your motor:
 - For 230 VAC motors, see Table 13.
 - For 460 VAC motors, see Table 14.
3. In the table you just selected, find the maximum output current that just exceeds the motor's maximum current consumption and use the VFD68 part number associated with this maximum output current as the recommended drive for the motor.
4. Use the same table to determine the recommended cable wiring size for the output current rating.

Table 13: 230 VAC, VFD68Bxx Drives, Maximum Output Amperes and Wiring Sizes

Part Number	Rated Capacity, kW (HP)	Maximum Output Current (Amperes)	Cable Wire Size				
			AWG ¹		PVC wires, (mm ²) ²		
			R/L1, S/L2, T/L3	U, V, W	R/L1, S/L2, T/L3	U, V, W	Earthing (Ground) cable
VFD68BBB	0.1 (1/8)	0.8	14	14	2.5	2.5	2.5
VFD68BCB	0.2 (1/4)	1.4	14	14	2.5	2.5	2.5
VFD68BDC	0.4 (1/2)	2.5	14	14	2.5	2.5	2.5
VFD68BFD	0.75 (1)	4.2	14	14	2.5	2.5	2.5
VFD68BGG	1.5 (2)	7.0	14	14	2.5	2.5	2.5
VFD68BHG	2.2 (3)	10.0	14	14	2.5	2.5	2.5
VFD68BJK	3.7 (5)	16.5	12	12	4	4	4
VFD68BKL	5.5 (7-1/2)	23.8	10	10	6	6	6
VFD68BLL	7.5 (10)	31.8	6	8	16	10	6
VFD68BMP	11 (15)	45.0	6	6	16	16	16
VFD68BNP	15 (20)	58.0	4	4	25	25	16

1. The recommended cable wire size is that of the cable (THHW cable) with a continuous maximum permissible temperature of 75°C (167°F). Assumes that the surrounding air temperature is 40°C (104°F) or less. (Selection example for use mainly in the United States.)
2. The recommended cable wire size is that of the cable (PVC cable) with a continuous maximum permissible temperature of 70°C (158°F). Assumes that the surrounding air temperature is 40°C (104°F) or less. (Selection example for use mainly in Europe.)

Table 14: 460 VAC, VFD68Cxx Drives, Maximum Output Amperes and Wiring Sizes

Part Number	Rated Capacity, kW (HP)	Maximum Output Current (Amperes)	Cable Wire Size				
			AWG ¹		PVC wires, (mm ²) ²		
			R/L1, S/L2, T/L3	U, V, W	R/L1, S/L2, T/L3	U, V, W	Earthing (Ground) cable
VFD68CDF	0.4 (1/2)	1.2	14	14	2.5	2.5	2.5
VFD68CFF	0.75 (1)	2.2	14	14	2.5	2.5	2.5
VFD68CGG	1.5 (2)	3.6	14	14	2.5	2.5	2.5
VFD68CHH	2.2 (3)	5.0	14	14	2.5	2.5	2.5
VFD68CJJ	3.7 (5)	8.0	14	14	2.5	2.5	2.5
VFD68CKL	5.5 (7.5)	12.0	12	14	4	2.5	4
VFD68CLL	7.5 (10)	16.0	12	12	4	4	4
VFD68CMP	11 (15)	23.0	10	10	6	6	10
VFD68CNP	15 (20)	29.5	8	8	10	10	10

1. The recommended cable wire size is that of the cable (THHW cable) with a continuous maximum permissible temperature of 75°C (167°F). Assumes that the surrounding air temperature is 40°C (104°F) or less. (Selection example for use mainly in the United States.)
2. The recommended cable wire size is that of the cable (PVC cable) with a continuous maximum permissible temperature of 70°C (158°F). Assumes that the surrounding air temperature is 40°C (104°F) or less. (Selection example for use mainly in Europe.)

Calculating the Maximum Wire Length

1. Use the recommended wire size in accordance with local, national, and regional regulations to determine the electrical resistance of the wire (R) according to Table 15.

Table 15: Electrical Resistance by Wire Size

Recommended Wire Size ¹	Electrical Resistance of Wire (milliohms/meter)	Recommended Wire Size ¹	Electrical Resistance of Wire (milliohms/meter)
25 mm ²	0.727	5.3 mm ² (10 AWG)	3.28
21.2 mm ² (4 AWG)	0.815	4 mm ²	4.61
16 mm	1.15	3.3 mm ² (12 AWG)	5.21
13.3 mm ² (6 AWG)	1.30	2.5 mm ²	7.41
10 mm ²	1.83	2 mm ² (14 AWG)	8.28
8.3 mm ² (8 AWG)	2.06	1.5 mm ²	12.1
6 mm ²	3.08		

1. The mm wire sizes that are given as equivalences to the AWG wire sizes are not commercially available.
2. Find the rated voltage (V) and maximum output current (I) from the rating plate on the selected VFD68 Drive.

3. Use Figure 8 to determine the maximum recommended wiring length for the VFD68 Drive.

$$\text{Maximum Wire Length} = \frac{(11.55 * V)}{(I * R)}$$

V = Voltage rating (230 or 460 VAC)

I = Maximum output current (Amps)

R = Electrical resistance of the wire
(milliohms/meter)

Figure 8: Maximum Wire Length Calculation

Note: If the maximum wire length needs to be extended, select a larger wire size and recalculate the maximum wire length. Do not exceed 100 m.

Note: Maximum wiring length is also affected by the setting of P. 72. See *PWM Frequency, Audible Motor Noise, and EMI* on page 34.

Example:

Given a VFD68BGG-2C model, what is the maximum wiring length?

- a. Table 1 on page 4 indicates that a VFD68BGG-2C model is a 230 VAC Drive, rated for 1.49 kW (2 HP).
- b. The rating information plate (Figure 1 on page 4) for that model indicates that the VFD68BGG Drive has a voltage rating of 230 VAC and a maximum output rating of 7 amperes.
- c. Table 13 on page 15 gives the recommended wire size as 14 AWG.
- d. Table 15 on page 16 shows 14 AWG size wire as having an electrical resistance of 8.28 milliohms/meter.
- e. Using the equation in Figure 8 on page 17 and using the values we found in the steps above:

$$(11.5 * 230) / (7 * 8.28) = 2656.6 / 57.96 = 45.8$$

The maximum wire length is 45.8 meters.

Making High-Voltage Wiring Connections

1. Loosen the screws on the front cover and remove the cover to access the low-voltage wiring (Figure 9).

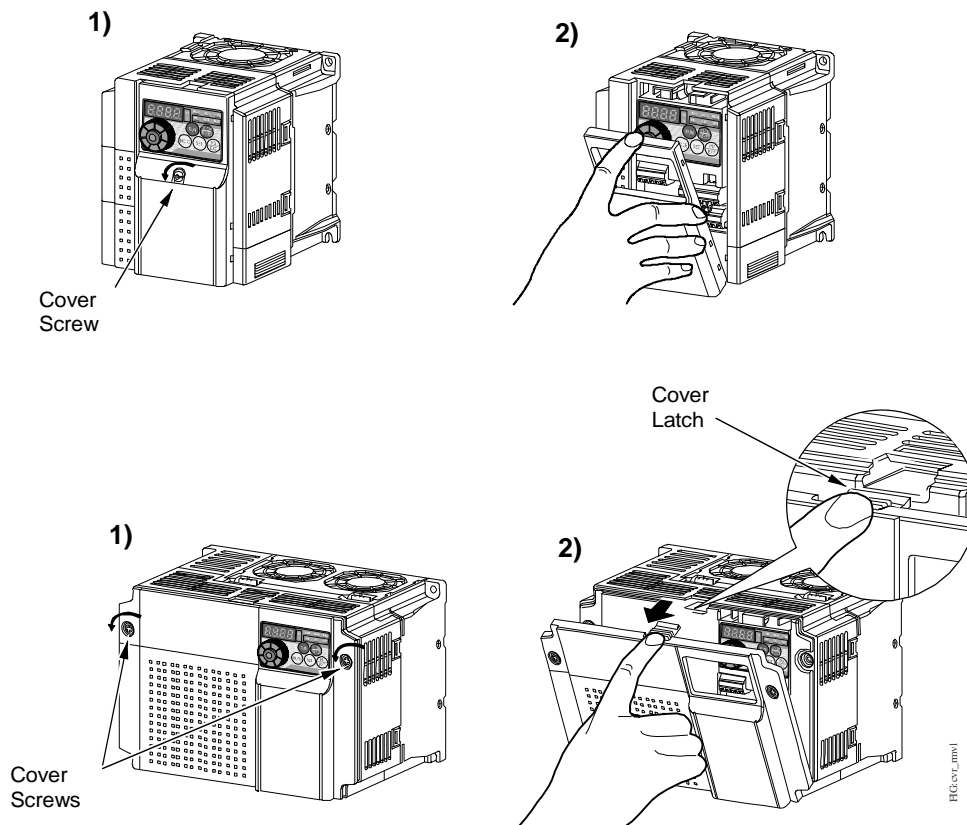

Figure 9: Loosen the Cover Screws and Remove the Front Cover

2. Remove the high-voltage wiring cover at the bottom of the VFD68 Drive (Figure 10).

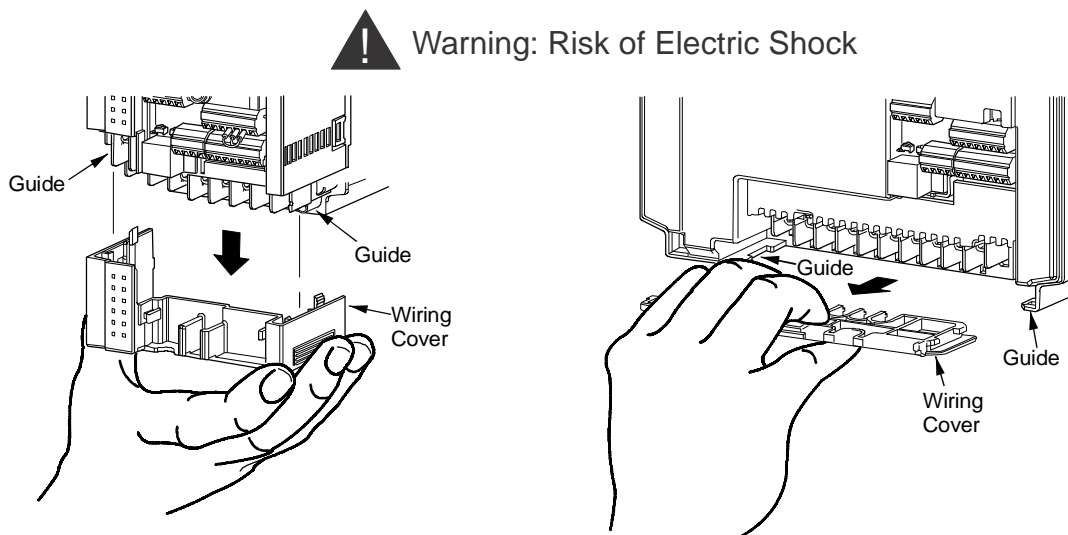

Figure 10: Remove the High-Voltage Wiring Cover

IMPORTANT: Use UL Listed copper, stranded wire with insulation rated at 75°C (167°F) for wiring in Step 3 and Step 4. See *High-Voltage Wire Size and Maximum Wire Length* on page 15.

3. Connect the high-voltage power supply to terminals R/L1, S/L2, and T/L3 on the drive (Figure 11).

Note: If three-phase power is not available as supply power for the VFD68 Drive, refer to the *VFD68 Variable Frequency Drive Technical Bulletin (Part No. 24-7664-3051)*.

4. Connect the motor wiring to high-voltage output terminals U, V, and W on the drive (Figure 11).

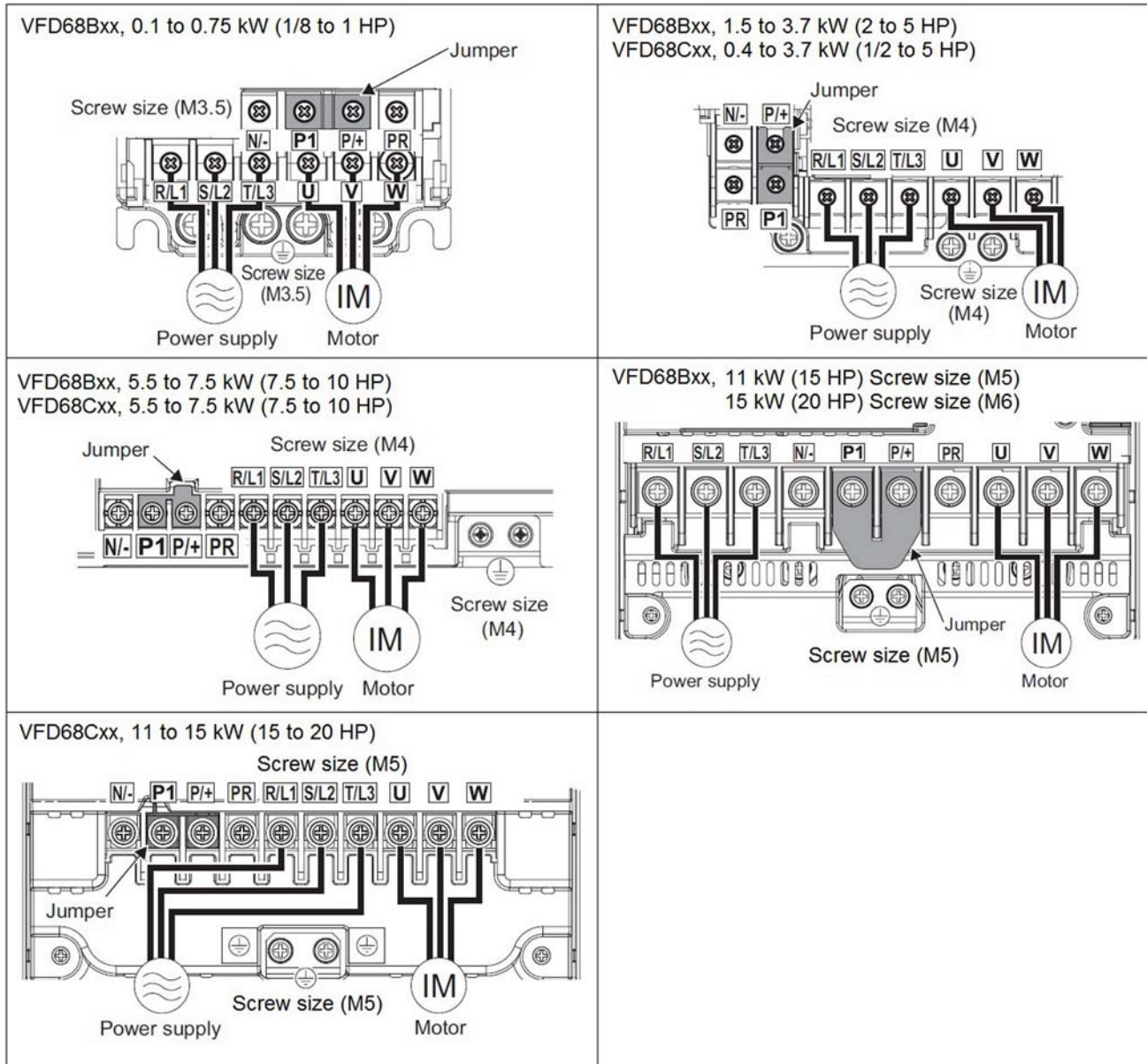

Figure 11: High-Voltage Terminal Block Wiring

5. Connect earth ground wiring to the earth ground terminals on the VFD68 Drive and on the motor.

6. Replace the high voltage wiring cover.

Note: When replacing the high-voltage cover, carefully space and position the leads through the vents or wire slots.

Making Low-Voltage Wiring Connections

IMPORTANT: If using two input devices, both devices must be identical. Do not use input devices with different ranges and operating characteristics.

Low-voltage wiring terminals are located underneath the front cover. See Figure 12 and Table 16.

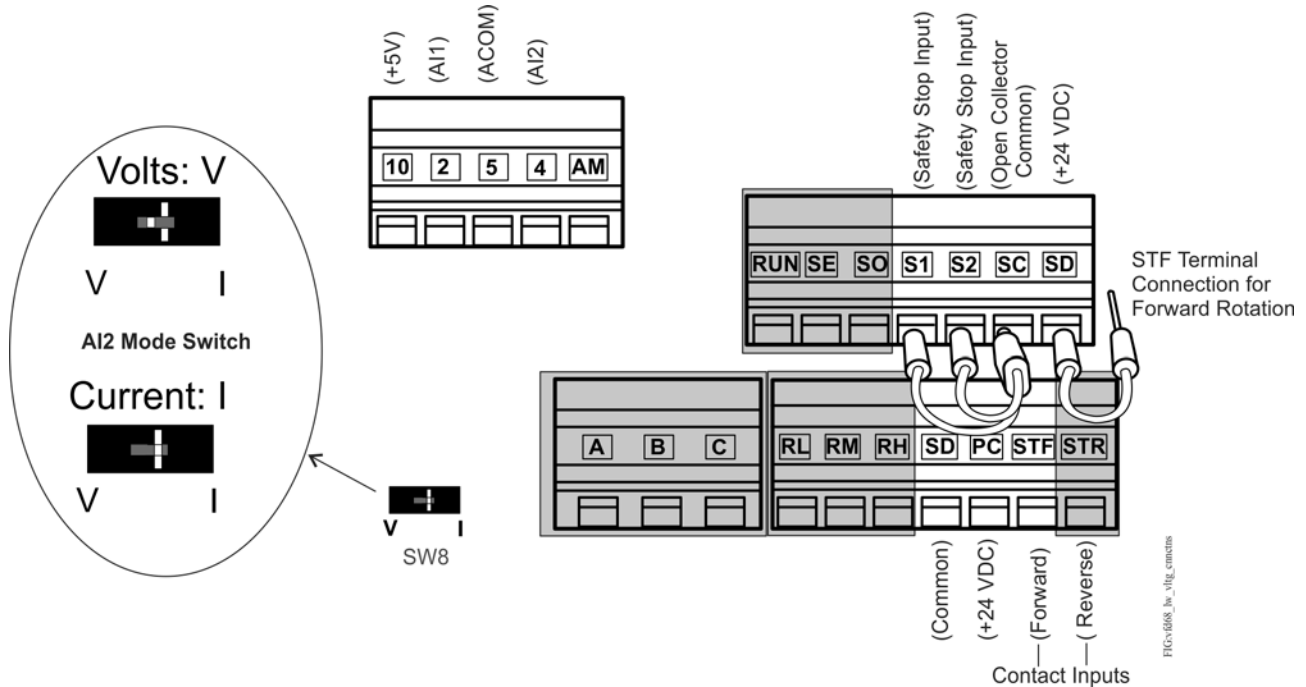

Figure 12: VFD68Bxx and VFD68Cxx Drives Low-Voltage Connections

Table 16: VFD68Bxx and VFD68Cxx Drives Low-Voltage Connections Information¹ (Part 1 of 2)

Terminal Label	Signal Type	Description
10	+5VDC	Provides + 5 VDC supply for P499R Transducers (15mA maximum)
2	Analog Input	Analog Input 1 (AI1) accepts 0–5 V or 0–10 V DC analog input signals
5	Analog Common	Common for analog inputs
4	Analog Input	Analog Input 2 (AI2) accepts 0–5 V, 0–10 V, or 4–20 mA analog input signals
AM	Analog Output	Provides a 0–10 VDC analog output signal corresponding to output frequency
RUN	Open Collector Transistor Output	VFD Running - Switched low (transistor conducts) when the VFD output frequency is higher than the start frequency (the motor is running). Switched high (transistor is off) when the motor is off.
SE	Open Collector Common	Common for RUN terminal
SO	Open Collector Transistor Output	Safety Stop Output
S1	Safety Stop Input	Terminals S1 and S2 must connect to terminal SC or the VFD shuts off.
S2	Safety Stop Input	Terminals S1 and S2 must connect to terminal SC or the VFD shuts off.
SC	Safety Stop Common	Common for S0, S1, and S2 terminals
SD	Common	Common for + 24 VDC Supply and contact inputs (using Sink logic - default setting)

Table 16: VFD68Bxx and VFD68Cxx Drives Low-Voltage Connections Information¹ (Part 2 of 2)

Terminal Label	Signal Type	Description
RL	Contact Input	Run Low Speed
RM	Contact Input	Run Medium Speed
RH	Contact Input	Run High Speed
SD	Common	Common for + 24 VDC Supply and contact inputs (when using Sink logic - default setting)
PC	+24 VDC	Provides + 24 VDC excitation voltage, 100 mA maximum, Use for P499A or P499V Transducers.
STF	Contact Input	Forward rotation. Must connect STF to SD terminal (common) using the factory-supplied jumper to allow the VFD to rotate in a forward direction.
STR	Contact Input	Reverse rotation (used to reverse motor rotation)
A	Relay Output (N.O.)	During normal operation, relay contacts A and C are open. (maximum alarm load: 230 VAC, 0.3 A or 30 VDC, 0.3 A)
B	Relay Output (N.C.)	During normal operation, relay contacts B and C are connected. (maximum alarm load: 230 VAC, 0.3 A or 30 VDC, 0.3 A)
C	Relay Output (C)	Relay output common

1. Gray cells indicate a terminal that is typically not used in condenser fan speed control applications.

Terminal RL (Run Low Speed) corresponds to P. 6; Terminal RM (Run Medium Speed) corresponds to P. 5; Terminal RH (Run High Speed) corresponds to P. 4. When one of these terminals is connected to SD (common) the VFD runs at the speed shown in the corresponding parameter.

Terminal STR (reverse rotation) is disabled by P. 78 setting = 1. This terminal is not useful for condenser fan speed control applications.

Terminals A, B, and C are connected to relay contacts that activate when a fault has occurred and the VFD output has stopped.

To connect the input signal devices:

1. Loosen the screws on the front cover and remove the cover to access the low voltage wiring (Figure 9 on page 18).
2. Locate the low-voltage wiring terminals (Figure 13).

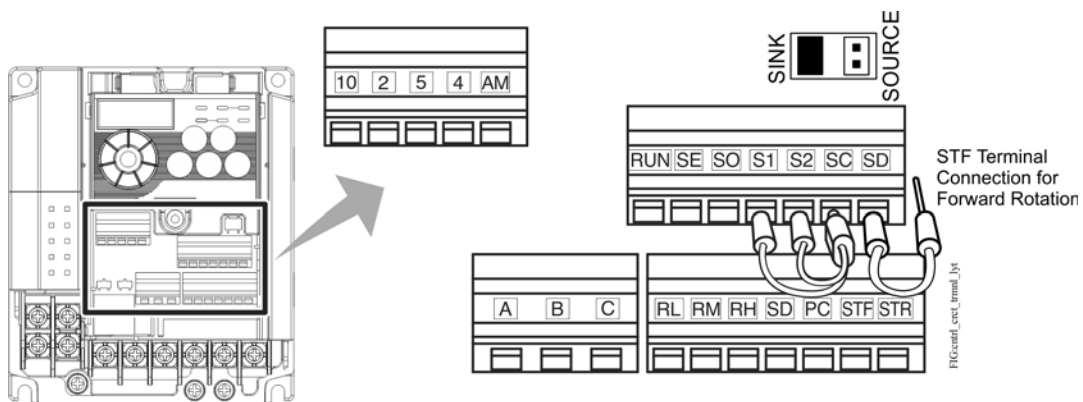

Figure 13: Locating the Low-Voltage Wiring Terminals

3. Push down on the orange tab to open the terminal (Figure 14).

IMPORTANT: Do not pull the wires out of the terminal block without pushing the orange tab all the way down. Pulling wires out of the low voltage terminal block without opening the terminal may damage the terminal block or circuit board.

4. Insert the wire and release the orange tab to secure the wire.

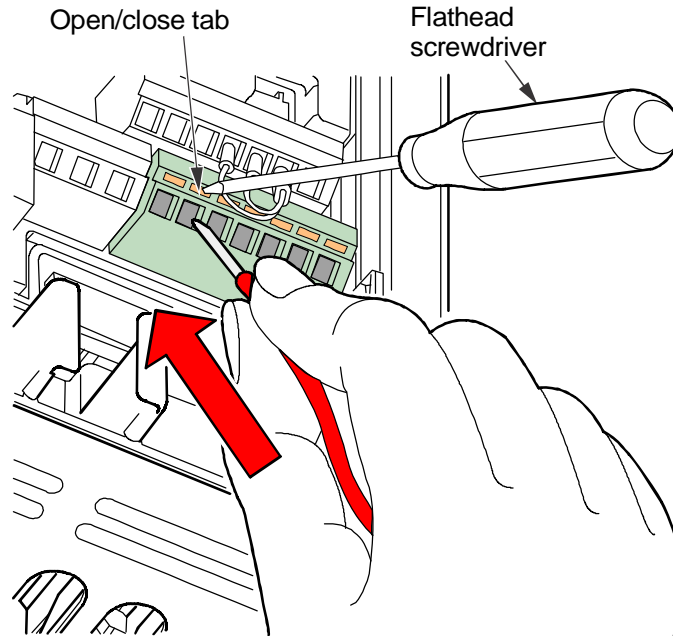

Figure 14: Wiring Analog Input Devices to the VFD68 Control

5. Wire the input devices to the analog input terminals (see *Making Low-Voltage Wiring Connections* on page 20) and make any necessary parameter adjustments.
6. Replace the front cover.

Input Wiring Connections

Wire the input device to the analog input terminals (Table 17) and make any necessary parameter adjustments. See *Setup and Adjustment* on page 26 and *Parameter Settings Calculations for Motor Speed vs. Pressure* on page 32 for more information.

Table 17: Wiring P499 Transducers as Input Devices

Signal	P499R Ratiometric Transducers	Analog Input Terminal
A11	white wire of first transducer	Terminal 2
A12	white wire of second transducer	Terminal 4
+5 V	red wire	Terminal 10
ACOM	black wire	Terminal 5

0.5–4.5 VDC Ratiometric P499 Transducer

The default parameter values (Table 21 on page 28) on the VFD68 Drive are configured to operate a condenser fan motor on an R410 condensing unit, using a P499RCP-107 or P499RAP-107 Ratiometric Transducer (or Transducers). Wire one transducer for single circuit condensing systems. Wire two transducers for dual circuit condensing systems (Figure 15).

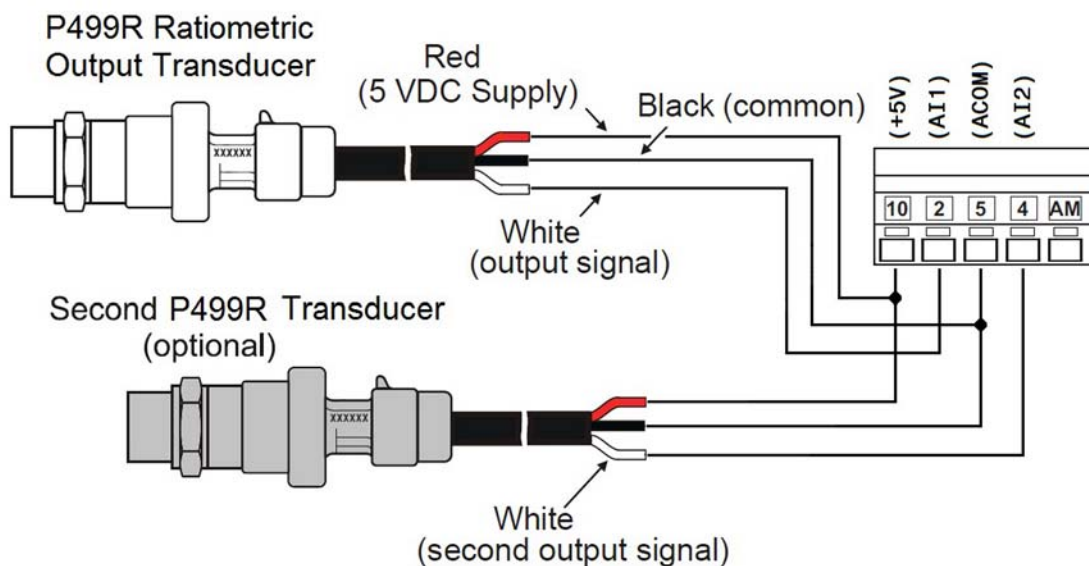

Figure 15: Wiring 0.5–4.5 VDC Ratiometric Input Signal Transducers

The VFD68 has the ability to control motor speed using the higher input signal value of two **voltage** inputs when you configure AI1 and AI2 as the same model transducer. For the **high-input signal select** application with two transducers (Figure 15 on page 23 or Figure 16 on page 24), use the parameter values in Table 18 and see [Adjusting the Default Parameters](#) on page 34.

Table 18: Settings for Single or Dual 0.5–4.5 VDC Ratiometric Transducers

Setting	Single Transducer	Dual Transducer, High-Signal Select
P. 73 ¹	1 (0–5 V)	1 (0–5 V)
P.266 ¹	1 (voltage input)	1 (voltage input)
P.267 ¹	1 (0–5 V)	1 (0–5 V)
Analog Input Terminal	AI1 or AI2	AI1 and AI2
AI2 Mode Switch ²	V	V

- For information on parameters, see Table 21 on page 28.
- See Figure 12 on page 20.

IMPORTANT: If using two voltage input devices, both devices must be identical. **Do not** use input devices with different ranges and operating characteristics.

For high-pressure refrigerants other than R410a, you must calculate and change the **C x** parameters. For medium and low pressure refrigerants, you must determine the proper P499R Transducer and then calculate and change the **C x** parameters.

For more information, see [Setup and Adjustment](#) on page 26 and [Parameter Settings Calculations for Motor Speed vs. Pressure](#) on page 32.

0–10 VDC P499 Transducer

For applications using a 0–10 VDC P499V Transducer, you must:

- adjust the parameter values that are listed in Table 19 on page 24
- ensure that the AI2 mode switch (Figure 12 on page 20) is set correctly
- calculate and change **C x** parameters based on the desired operating pressure range for the condensing fans on your application

The VFD68 has the ability to control motor speed using the higher input signal value of two **voltage** inputs when you configure AI1 and AI2 as the same model transducer. For the **high-input signal select** application with two transducers (Figure 15 or Figure 16), use the parameter values in Table 19 and see Figure 18 on page 27 *VFD68Bxx and VFD68Cxx Drive Basic and Advanced Parameters* on page 28, and *Adjusting the Default Parameters* on page 34.

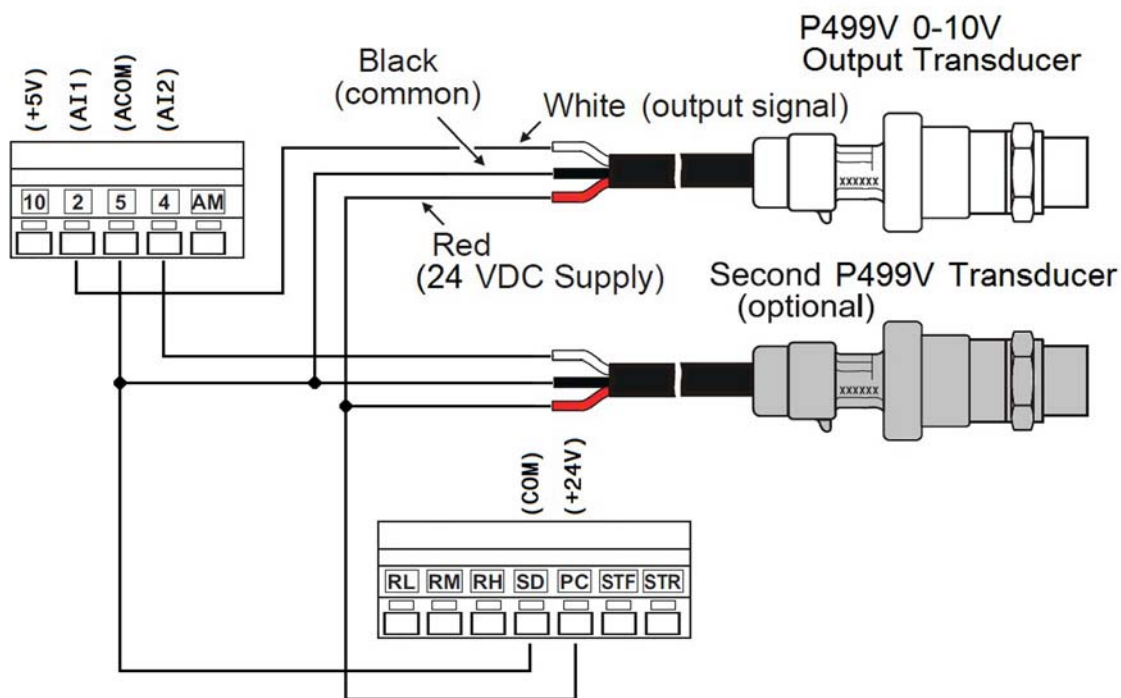

Figure 16: Wiring 0–10 VDC Input Signal Transducers

Table 19: Settings for Single or Dual 0–10 VDC Transducers

Setting	Single Transducer	Dual Transducer, High-Signal Select
P. 73 ¹	0 (0–10 V)	0 (0–10 V)
P.266 ¹	1 (voltage input)	1 (voltage input)
P.267 ¹	2 (0–10 V)	2 (0–10 V)
Analog Input Terminal	AI1 or AI2	AI1 and AI2
AI2 Mode Switch ²	V	V

1. For information on parameters, see Table 21 on page 28.

2. See Figure 12 on page 20.

IMPORTANT: If using two voltage input devices, both devices must be identical. **Do not** use input devices with different ranges and operating characteristics.

4–20 mA P499 Transducer

For applications using a 4–20 mA P499A Transducer (Figure 17), you must:

- set P.266 and P.267 to 0
- set the AI2 mode switch position to I (see *Configuring EXT Mode Using Analog Inputs* on page 36)
- calculate and change the C x parameters based on the desired operating pressure range for the condensing fans on your application

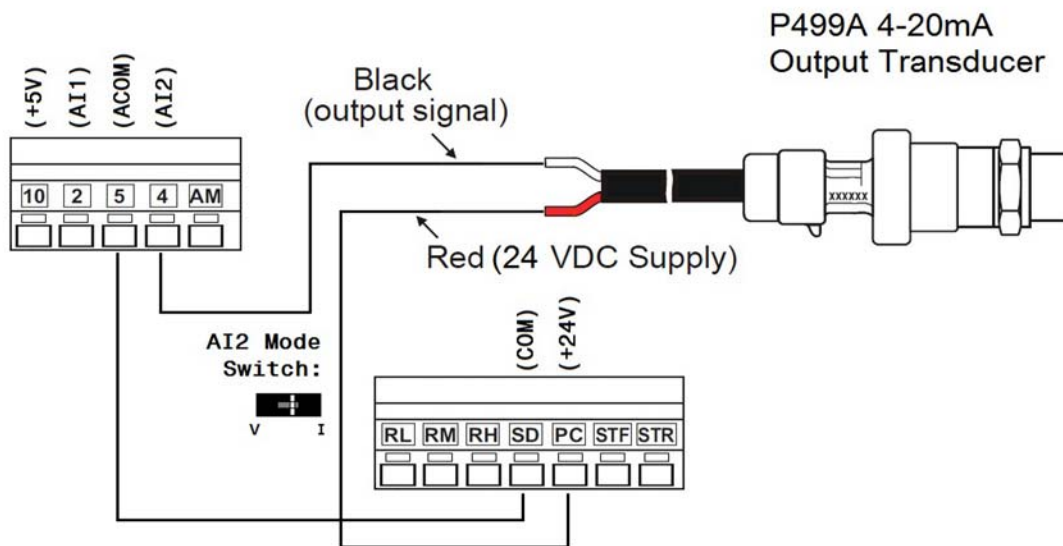



Figure 17: Wiring a 4–20 mA Input Signal Transducer

Table 20: Settings for Single 4–20 mA Transducer

Setting	Single Transducer, 4–20 mA
P. 73 ¹	N/A
P.266 ¹	0 (current input)
P.267 ¹	0 (4–20 mA)
Analog Input Terminal	AI2
AI2 Mode Switch ²	I

1. For information on parameters, see Table 21 on page 28.
2. See Figure 12 on page 20.

Setup and Adjustment

IMPORTANT: If the LED display shows an error code, press  and see [Troubleshooting](#) on page 36 for a list of fault or alarm indications, probable causes, and corrective actions.

Correspondences Between Digital and Actual Characters

The actual alphanumeric characters correspond to the following digital characters displayed on the operation panel:

Actual	Digital
0	0
1	1
2	2
3	3
4	4
5	5
6	6
7	7
8	8
9	9

Actual	Digital
A	A
B	b
C	C
D	d
E	E
F	F
G	G
H	H
I	I
J	J
L	L

Actual	Digital
M	m
N	n
O	O
o	o
P	P
S	S
T	T
U	U
V	V
r	r
-	-

Operation Modes

The VFD68 Drive mode of operation is indicated by the mode of operation LEDs (labeled PU, EXT, and NET) on the drive operation panel (Figure 18).

PU Mode: The Parameter Units (PU) mode is manual control mode. In PU mode, the drive and motor are completely controlled using the buttons and the setting dial on the drive user interface. No external analog signals or network signals control the drive operation. The PU mode is typically used to set up, test, and troubleshoot the drive and motor operation using controlled input signal values.

EXT Mode: In the External (EXT) mode, the drive and motor respond to a signal or signals from one or two (external) analog input signal devices such as pressure transducers or analog controllers. This is the typical mode of operation for the drive when it controls a condenser fan or other three-phase HVACR motor application.

PU/EXT Mode: In PU/EXT mode, the drive responds to the connected external signal devices and the drive setup values can be edited. The PU/EXT mode is typically used to set up your drive for initial operation, or to adjust setup parameters on an operating application.

NET Mode: In Network (NET) mode, the drive connects to and communicates over a network bus with other network devices and receives operating (Read/Write) commands from a master device on the network. The Network mode is not currently supported on VFD68 Drives.

The VFD68 Drives are RS485, RTU-compliant ModBus® slave devices. For more information, refer to the *VFD68 Variable Frequency Drive Technical Bulletin (Part No. 24-7664-3051)*.

MON Mode: Shows motor speed represented as frequency (Hz) or RPM.

RUN, MON, PRM LEDs

The RUN, MON, and PRM LEDs provide drive status and indicate the type of information being displayed on the operation panel monitor.

RUN LED: The LED state (on steady, flashing, or flickering) provides information regarding the drive and motor run status. See Figure 18 for more information.

MON LED: Indicates that the monitor is displaying the drive run status. Press (SET) to scroll through run frequency, output amperes, and output voltage.

PRM LED: Indicates that the monitor is set to display parameters and parameter values and allows you to view and edit parameter values.

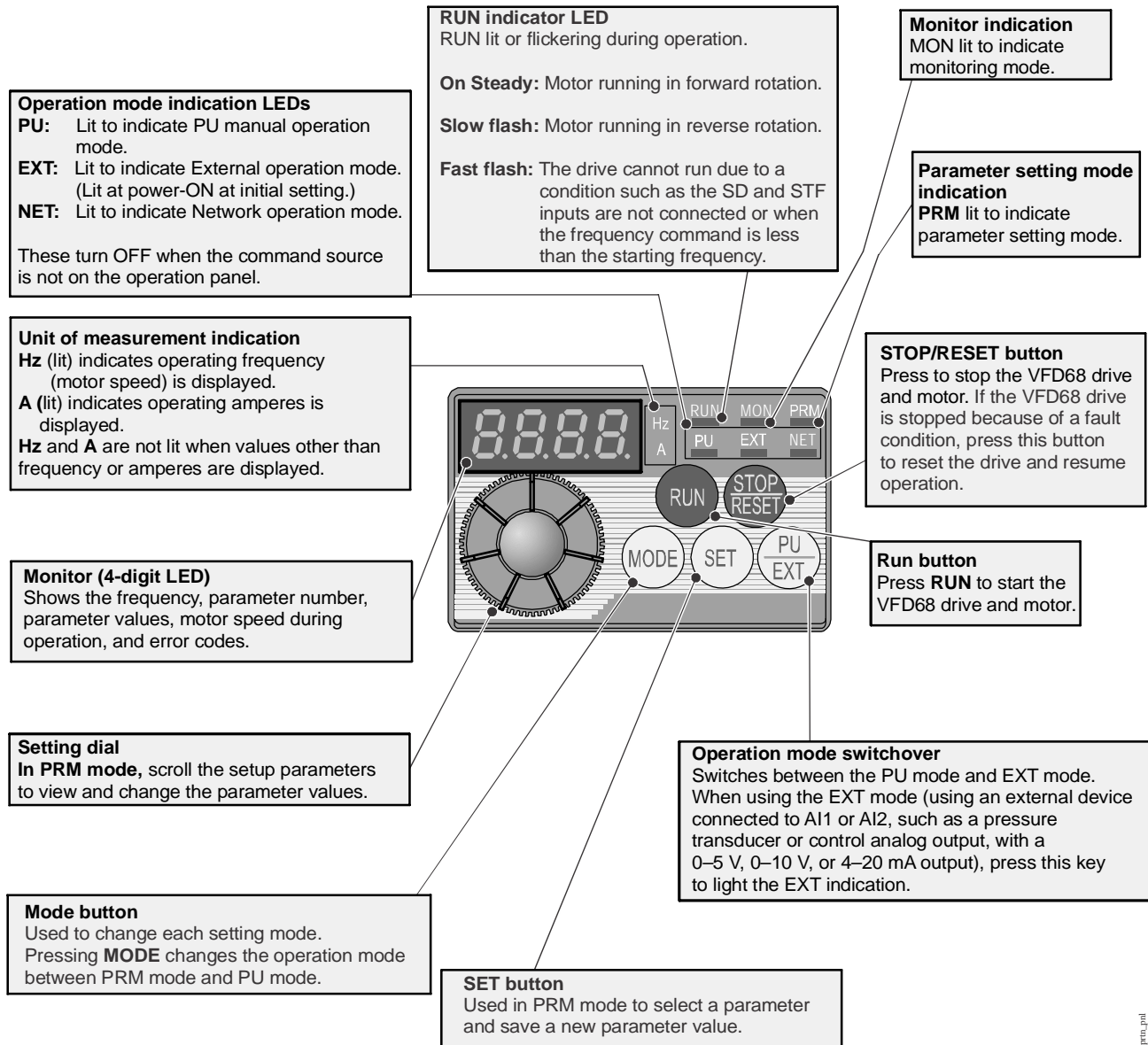

Figure 18: Operation Panel

FFG0ppm_jpn

VFD68Bxx and VFD68Cxx Drive Basic and Advanced Parameters

You can use the default parameter setting with the P499RxP-107C Transducer and R410a refrigerant within a range of operation that depends on the specific model of P499 Transducer selected. All other applications require some parameter changes and may require different transducers.

The parameters shown highlighted in gray in Table 21 are the advanced parameters. To view and change these parameters, change P.160 from 9999 to 0.

Table 21: Basic and Advanced Parameter Descriptions for VFD68Bxx and VFD68Cxx Drives
(Part 1 of 4)

Parameter Indication on Monitor	Description	Range	VFD68xxx-2 Defaults
P. 0	Torque Boost: Defines the voltage (% total V) applied to the motor when the drive starts the motor at 0 Hz.	0–30%	6%/4%/3%
P. 1	Maximum Frequency: Defines the maximum speed of the motor in your application. See Figure 19.	0–120 Hz	60 Hz
P. 2	Minimum Frequency: Defines the minimum speed of the motor in your application. See Figure 19.	0–120 Hz	12.5 Hz
P. 3	Base Frequency: Set parameter to the rated frequency [Hz] on motor rating plate.	0–400 Hz	60 Hz
P. 4	High Speed: The speed, or frequency, that the VFD68 output drives the attached motor when terminal RH is connected to terminal SD (common).	0–400 Hz	40 Hz
P. 5	Middle Speed: The speed, or frequency, that the VFD68 output drives the attached motor when terminal RM is connected to terminal SD (common).	0–400 Hz	20 Hz
P. 6	Low Speed: The speed, or frequency, that the VFD68 output drives the attached motor when terminal RL is connected to terminal SD (common).	0–400 Hz	10 Hz
P. 7	Acceleration Time: Defines the time required to accelerate from stop (0 Hz) to full rated RPM (60 Hz).	0–3600 seconds	15 seconds
P. 8	Deceleration Time: Defines the time required to decelerate from full rated RPM (60 Hz) to stop (0 Hz).	0–3600 seconds	15 seconds
P. 9	Motor Rated Current: Set parameter to the rated FLA (full load amperes) on motor rating plate.	0–500 A	Rated VFD68 Output
P. 19	Base Frequency Voltage: Defines the drive maximum output voltage relative to the drive supply voltage. (9999: drive maximum output voltage is the same as the drive power supply voltage.)	0–1000V, 9999	9999
P. 20	Acceleration/Deceleration Reference Frequency: Defines the high end frequency for P. 7 and P. 8.	0–400 Hz	60 Hz
P. 22	Stall Prevention Output Current Level: Defines the current level (as a percent of motor FLA) at which the drive begins to adjust the output frequency (Hz) to reduce the output current.	0–200%	150%
P. 31	Frequency Jump 1A: Frequency Jump parameters (P. 31 and P. 32) are used to set the low speed behavior of the drive. This parameter typically remains at 0 Hz.	0–400 Hz, 9999	0 Hz
P. 32	Frequency Jump 1B: maximum frequency to skip over to avoid very low fan airflow and unnecessary motor overheating (9999: frequency jump not enabled.) Ensure that P. 32 is set equal to C. 2 and C. 5	0–400 Hz, 9999	12.5 Hz
P. 33	Frequency Jump 2A: To avoid resonance noise caused by natural frequency of mechanical system, enter frequency just below noisy frequency 2.	0 to 400 Hz, 9999	9999

**Table 21: Basic and Advanced Parameter Descriptions for VFD68Bxx and VFD68Cxx Drives
(Part 2 of 4)**

Parameter Indication on Monitor	Description	Range	VFD68xxx-2 Defaults
P. 34	Frequency Jump 2B: To avoid resonance noise caused by natural frequency of mechanical system, enter frequency just above noisy frequency 2.	0 to 400 Hz, 9999	9999
P. 35	Frequency Jump 3A: To avoid resonance noise caused by natural frequency of mechanical system, enter frequency just below noisy frequency 3.	0 to 400 Hz, 9999	9999
P. 36	Frequency Jump 3B: To avoid resonance noise caused by natural frequency of mechanical system, enter frequency just above noisy frequency 3.	0 to 400 Hz, 9999	9999
P. 37	Speed Display: Set the drive to display motor in RPMs (instead of Hz) by entering the maximum rated motor speed from the motor nameplate. When set to 0, the drive displays speed in Hz.	0, 0.01–9998	0
P. 40	Run Key Rotation Direction: Determines motor rotation direction when you press the RUN key. 0 = forward rotation; 1 = reverse rotation	0,1	0
P. 57	Restart Coasting Time: Determines the waiting time for a restart after a power failure.	0.1–5	5 seconds
P. 58	Restart Cushion Time: Determines the duration of linear voltage ramp-up during a restart after a power failure.	0–40	25 seconds
P. 60	Energy Saving Control Selection: Select 9 for energy-saving operation that is optimized for fan and pump applications.	9	9
P. 65	Retry Selection: Select 4 to allow the VFD to restart after most conditions causing a trip (but not after thermal overload) while the VFD operates/runs	4	4
P. 67	Number of Retries at Fault Occurrence: The number of consecutive retries that will occur after a fault occurs. If this number is exceeded and the drive fails to start, then a Fault Signal (ALM) will occur.	0–10	3
P. 68	Retry Wait Time: Defines the time delay (in seconds), after a fault shutdown, before the drive attempts to restart the motor.	0.1–600 seconds	10 seconds
P. 71	Applied Motor: 0: Standard motor; 13: Constant torque motor	0, 13	0
P. 72	PWM Frequency Selection: Allows you to reduce audible noise by changing the PWM frequency (Hz).	0 to 15 ¹	1
P. 73	Analog Input 1 Type: Defines the input signal voltage range and motor rotation direction. (0: 0–10 VDC, 1: 0–5 VDC, 10: 0–10 VDC, and 11: 0–5 VDC).	0, 1, 10, 11	1
P. 77	Parameter Write Select: Enables or disables writing (changing) certain parameters and defines when parameters may be written (0: write when VFD stopped, 1: write disabled, 2: write enabled anytime).	0, 1, 2	2
78	Reverse Rotation Prevention Select: 0= Both forward [STF] and reverse [STR] allowed; 1=Reverse rotation [STR] disabled; 2=Forward rotation [STF] disabled	0, 1, 2	1
P.160	Extended Function Display Selection: Defines whether to display only simple parameters or all parameters (simple and advanced) (9999: display only simple parameters; 0: display all parameters).	9999, 0	9999
P.161	Frequency Setting/Key Lock Operation Select: 10 = change speed on dial, then press SET to change VFD speed; 11 = change speed on dial to instantly change VFD speed	10, 11	11

**Table 21: Basic and Advanced Parameter Descriptions for VFD68Bxx and VFD68Cxx Drives
(Part 3 of 4)**

Parameter Indication on Monitor	Description	Range	VFD68xxx-2 Defaults
P.162	Auto Restart After Instantaneous Power Failure: 1 = Enable without frequency search, 0 = Enable with frequency search	0, 1	1
P.167	Output Over Current Detection: 0 = no motor stoppage when over current occurs, 1= motor stops when over current occurs	0, 1	0
P.241	Analog Input Display Unit Switchover: 0 = display in 0.1% increments, 1 = display in 0.01V/0.01mA increments	0, 1	1
P.250	Stop Selection: 9999 = decelerate to stop, 1 = coast to stop	9999, 1	9999
P.255	Life Alarm Status Display: Displays remaining-life status of the control circuit capacitor, main circuit capacitor, cooling fan, and inrush current limit circuit (0: new; 15: end of life)		Read Only
P.256	Inrush Current Limit Circuit Life Display: Displays the deterioration level of inrush current limit circuit. (100[%]: new, 0[%]: end of life)		Read Only
P.257	Control Circuit Capacitor Life Display: Displays deterioration level of control circuit capacitor (100[%]: new, 0[%]: end of life).		Read Only
P.266	Set to 1 to enable voltage high signal select using both analog inputs (and set switch to V). Set to 0 to enable analog input 2 (Terminal 4) as a current input (and set AI2 mode switch to I).	0, 1	1
P.267	Analog Input 2 (AI2) Mode: Defines the input signal type to be connected to terminal 4. (Select 0 for 4–20 mA and position AI2 mode switch to I, or select 1 for 0–5 V or 2 for 0–10 V and position AI2 mode switch to V.)	0, 1, 2	1
P.295	Magnitude of Frequency Change: 0.1 = Frequency changes by 0.1 increments by rotation the selection dial.	0.1	0.1
P.296	Password Lock Level: Defines the read/write access level when password lock is enabled. (9999: No password lock; 1–6 or 101–106 = Set read/write restriction level when a password is implemented). Refer to the <i>VFD68 Variable Frequency Drive Technical Bulletin (Part No. 24-7664-3051)</i> .	1–6, 101–106, 9999	9999
P.297	Password Lock and Error Count: If P.296 is 1–6 or 101–106, then password can be implemented from 1000 to 9998. After password is implemented, this parameter counts up to 5 password unlock failures. If P.296 is 9999, then P.297 is 9999, no password lock, read only.	1000–9998, (0–5, 9999)	9999
P.299	Rotation Direction Detection: 0 = disabled; 1 = enabled Example: If P. 78=1 and the controlled motor starts, but the VFD detects reverse rotation, the VFD decelerates the motor to a stop and then runs the motor in a forward direction.	0,1	1
P.549	Communication Bus Protocol Selection: 0= drive protocol, 1 = ModBus RTU	0,1	1
P.882	Regenerative Avoidance Operation Selection: 1 = Regenerative avoidance is always valid. If the VFD Drive detects over-voltage, the VFD Drive increases the frequency to avoid an over-voltage fault.	1	1
C 2	Analog Input 1 - Minimum speed defined as frequency.	0–400 Hz	12.5 Hz
C 3	Analog Input 1 - Input voltage to start minimum speed ramp	0–300%	1.90 V (38%)
C 4	Analog Input 1 - Input voltage for setpoint (where motor reaches maximum frequency or speed)	0–300%	2.74 V (54.8%)
C 5	Analog Input 2 - Minimum speed (frequency)	0–400 Hz	12.5 Hz

**Table 21: Basic and Advanced Parameter Descriptions for VFD68Bxx and VFD68Cxx Drives
(Part 4 of 4)**

Parameter Indication on Monitor	Description	Range	VFD68xxx-2 Defaults
C 6	Analog Input 2 - Input voltage or current to start minimum speed ramp	0–300%	1.90 V or 7.6 mA (38%)
C 7	Analog Input 2 - Input voltage or current for setpoint (where motor reaches maximum frequency or speed)	0–300%	2.74 V or 11 mA (54.8%)

1. A setting value of 0 indicates 0.7 kHz. A setting of 1 indicates 1 kHz. A setting value of 15 indicates 15 kHz.

Frequency and Motor Speed

Frequency (Hz) is an expression of motor speed (RPM) on the VFD. Figure 19 and Figure 20 show how the drive operating frequency is related to the speed (RPM) of the motor.

The VFD68Bxx and VFD68Cxx Drive models can be configured to display operating frequency (Hz) or motor speed (RPM). To display motor speed (RPM) instead of operating frequency (Hz):

1. Set P.160 to 0.
2. Set P. 37 to the rated motor RPM value.
3. Set P.160 to 9999.

See [Adjusting the Default Parameters](#) on page 34.

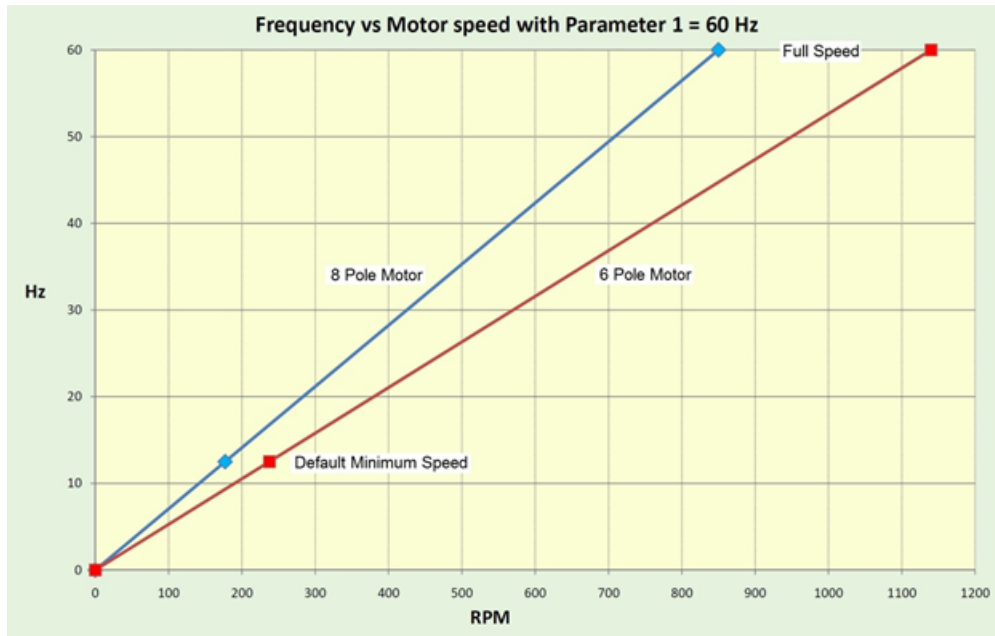

Figure 19: Frequency and Motor Speed (60 Hz)

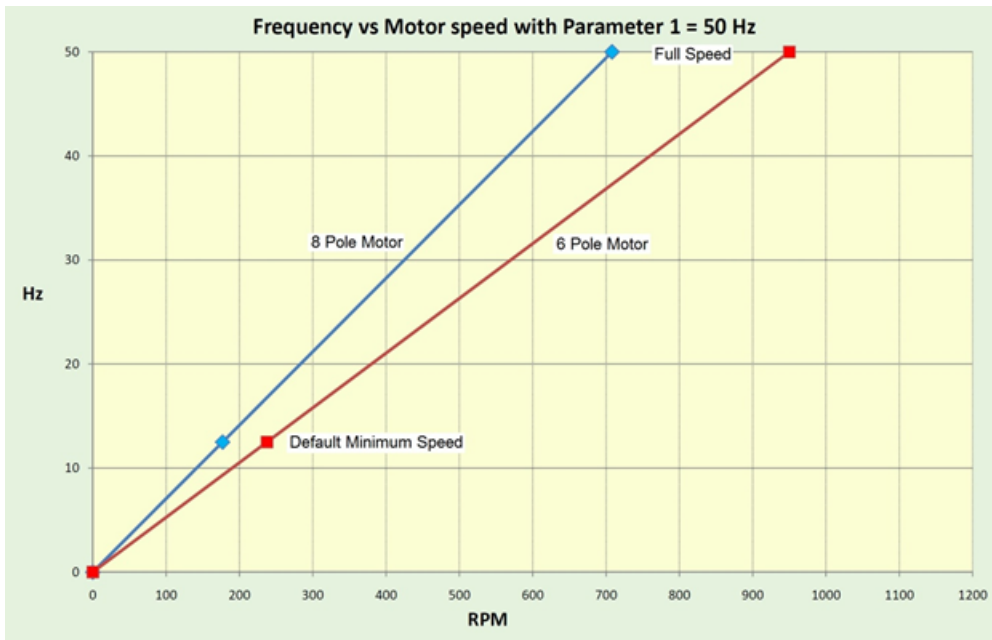
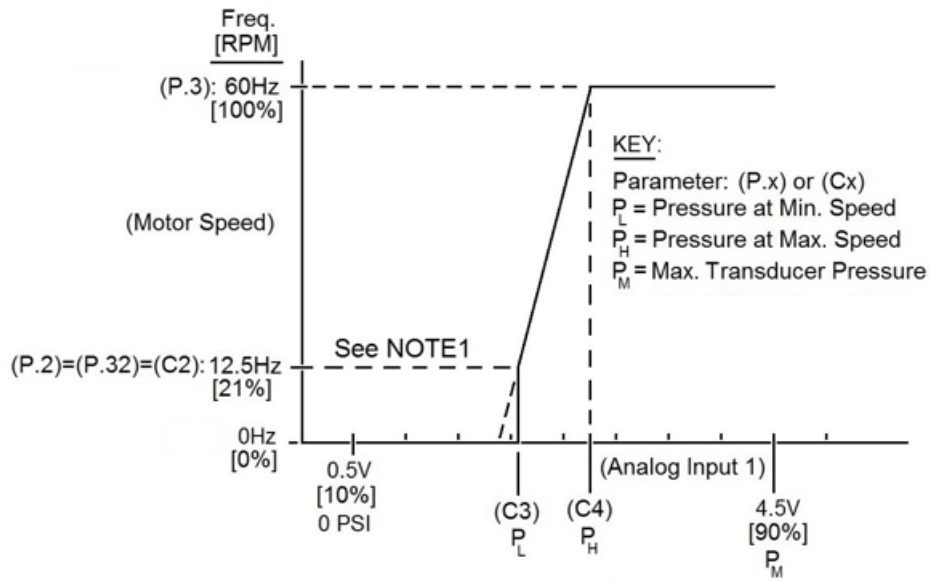

Figure 20: Frequency and Motor Speed (50 Hz)

Parameter Settings Calculations for Motor Speed vs. Pressure



Calculate Parameter (C3): $(C3) = 0.5 + \left(\frac{4 * P_L}{P_M}\right)$

Calculate Parameter (C4): $(C4) = 0.5 + \left(\frac{4 * P_H}{P_M}\right)$

NOTE1: When using the default settings: P.31=0Hz and P.32=12.5Hz, and the pressure drops below P_L, the motor will shut off.

Figure 21: Applications Using 0.5–4.5 V Ratiometric Transducers

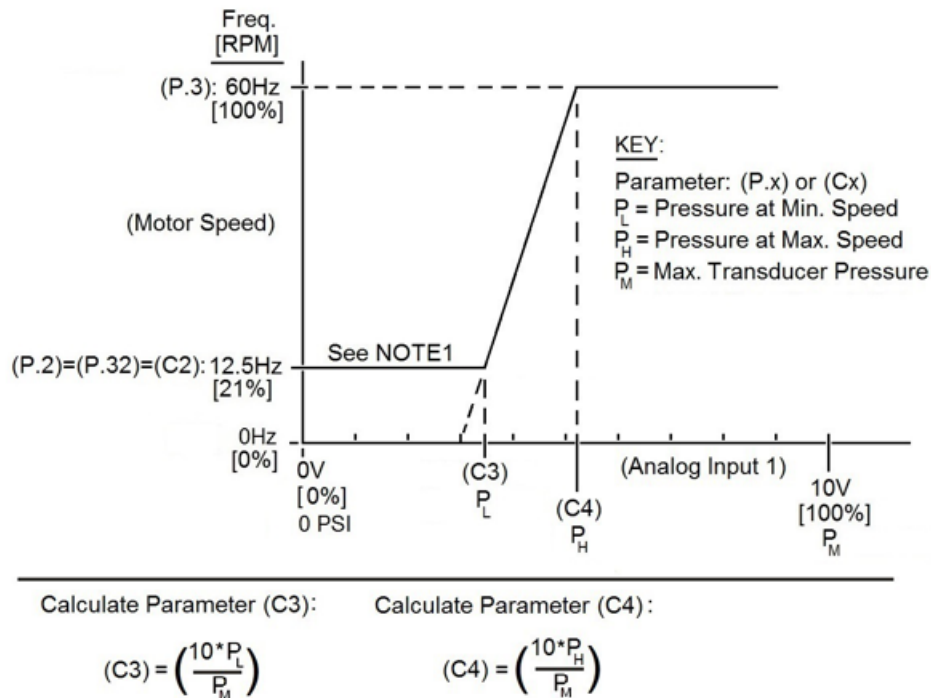

NOTE1: Set (P.32) to 9999 to cause the motor to run continuously at Min. Speed below P_L .

Figure 22: Applications Using 0–10 V Transducers

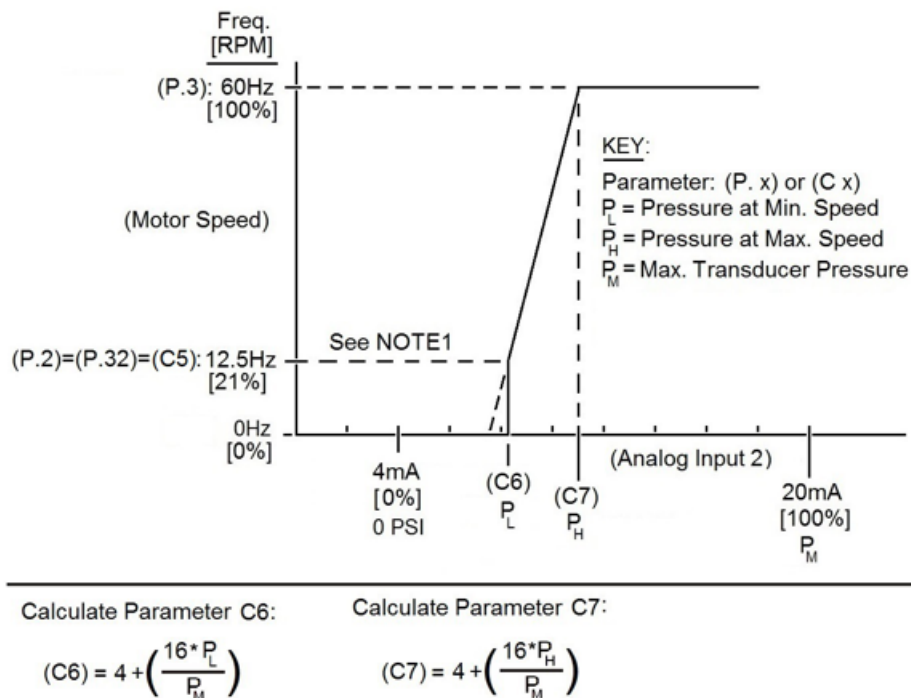

NOTE1: When using the default settings: P.31=0Hz and P.32=12.5Hz, and the pressure drops below P_L , the motor will shut off.

Figure 23: Applications Using 4–20 mA Transducers

PWM Frequency, Audible Motor Noise, and EMI

Using the default setting (P. 72 = 1), EMI (electromagnetic interference) radiation and leakage current from the wiring between the VFD68 Drive and the motor is low; however, there is a high level of audible motor noise. As the setting for P. 72 increases (up to P. 72 = 15, frequency = 15 kHz), audible motor noise decreases while EMI radiation and leakage current increases.

If the audible noise from the VFD is too great with P.72 set to 1, increase the setting to 4 and listen to the audible noise. To minimize the EMI radiation, use the smallest number possible for P. 72.

Adjusting the Default Parameters



CAUTION: Risk of Property Damage.

Do not apply power to the system before checking all wiring connections. Short circuited or improperly connected wires may result in permanent damage to the equipment.



MISE EN GARDE: Risque de dégâts matériels.

Ne pas mettre le système sous tension avant d'avoir vérifié tous les raccords de câblage. Des fils formant un court-circuit ou connectés de façon incorrecte risquent d'endommager irrémédiablement l'équipement.

Enter the Parameter Adjustment Mode





1. Remove the jumper that connects terminal SD to terminal STF.

IMPORTANT: Remove the jumper to stop the motor before you change the parameter values.

2. Turn the power on. The monitor display appears. (The VFD68 Drive is in EXT Mode.)
3. Press  to exit EXT mode and go to PU mode (manual override operation mode). The PU LED illuminates.
4. Press  to select PRM mode (parameter setting mode). The PRM LED illuminates.

Note: See Table 21 on page 28 for information on the parameters.







Select and Change Most Parameters

5. Turn  to select a parameter number on the display. Example: **P. 32**
6. Press  to show the parameter value. (The default value for **P. 32** is **12.5**.)
7. Turn  to change the parameter value. (Set **P. 32** to **9999** if the motor is to run at minimum speed during low pressure events).
8. Press  twice to store the new value.
9. Press  again to show the next parameter.

To select and change the value of another parameter, repeat Step 5 through Step 9.



To adjust the C-Prefix parameters, go to Step 10. If finished, go to Step 16.

Select and Change C-Prefix Parameters

10. Turn  until **C...** appears.
11. Press . **C---** appears.
12. Turn  slightly until the C-prefix parameter that you want to change appears. See Table 21 on page 28.
13. Press , then turn  slightly to read the present set value.
14. Turn  again to change the parameter value.
15. Press  twice to store the new value. **C---** appears on the LED display.

To select and change the value of another C-prefix parameter, repeat Step 12 through Step 15.

Exit the Parameter Adjustment Mode

16. Press  twice to exit parameter setting mode (PRM mode) and enter manual operation mode (PU mode). The PU LED illuminates.
17. Press  twice to exit PU mode and enter EXT RUN mode for normal operation. The EXT LED illuminates.
18. Use the jumper wire to connect terminal SD to terminal STF to run the motor using the analog input.

Configuring Manual Motor Speed Control in PU Mode

Verify that the VFD68 is in PU mode with no jumper between SD and STF (Figure 24).

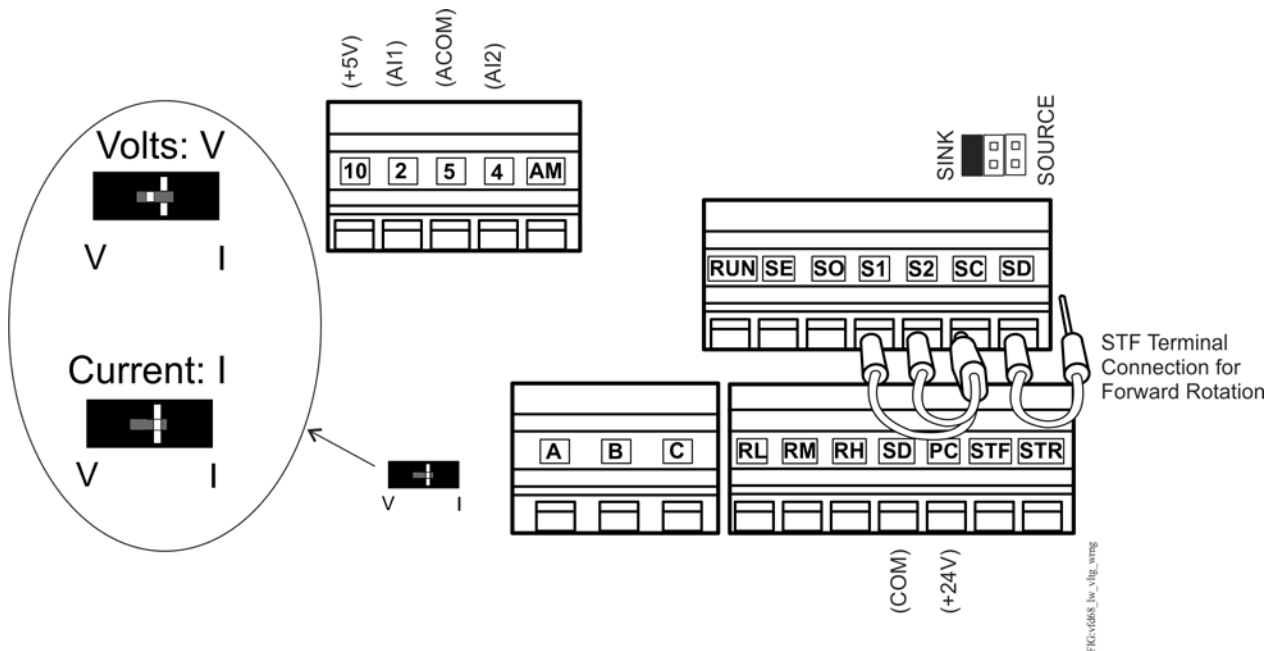









Figure 24: VFD68 Setup and Low-Voltage Connections

1. If the **PU** LED is not illuminated, press  until the **PU** LED comes on.

2. Press  to start the VFD68 output to the motor.
3. Turn  to change motor speeds. Run the motor at high speed, maximum frequency.
4. Verify that the motor FLA (Full Load Amps) is correct using one of the following methods:
 - Use a clamp-on amp meter
 - Press  repeatedly until **MON** LED is on; press  until the LED display shows **A** for amperes instead of **Hz** for frequency.
5. Press  to stop the output to the motor.

Configuring EXT Mode Using Analog Inputs

Verify that the VFD68 is in PU mode with no jumper between SD and STF (Figure 24 on page 35).

1. Verify that the jumper above terminal **SC** (Figure 24) is set to **SINK**.
2. Verify that the AI2 mode switch to the left of terminal **A** (Figure 24) is set to **V** for applications with 0–5 V or 0–10 V voltage input or set to **I** for applications with 4–20 mA current input.
3. Exit the PU (manual operation) mode by pressing  until the **EXT** LED is highlighted, then use a jumper to connect SD to STF.

Note: The jumper between SD and STF must be connected for the VFD68 Drive to run.

The VFD68 is now commissioned, is in the external operation mode, and is ready to run the motor using the analog inputs.

Troubleshooting

When an improper operating condition occurs in the VFD, the operation panel display changes to one of the status indications shown in Table 23. If the fault does not correspond to any of the faults in Table 23 (or if you have any other problem), refer to the *VFD68 Variable Frequency Drive Technical Bulletin (Part No. 24-7664-3051)*.

Table 22 defines the indication categories. Table 23 provides descriptions of the individual indicator messages.

Table 22: Indication Categories on the Operation Panel Display

Indication Category	Description
Error message	A message regarding operational or setting errors displays. The VFD continues operating.
Warning	The VFD continues operating. Failure to take appropriate measures will lead to a fault.
Alarm	The VFD continues operating. You can also output an alarm signal by adjusting a parameter setting.
Fault	When a fault occurs, the VFD output reduces to 0 Hz, the motor stops, and the VFD outputs a fault signal.

When a fault occurs, take the appropriate corrective action, then reset the VFD and resume operation. See *Resetting the VFD68 Drive* on page 39. Failure to take corrective action and reset the VFD may lead to a repeat of the fault condition and damage the VFD. For further information on troubleshooting, refer to the *VFD68 Variable Frequency Drive Technical Bulletin (Part No. 24-7664-3051)*.

Table 23: Indicator Messages (Part 1 of 2)

Operation Panel Indication		Name		
Error message	<i>E---</i>	E---	Faults history	
	<i>HOLD</i>	HOLD	Operation panel lock	
	<i>E. S</i> <i>Er2</i> <i>Er3</i> <i>Er4</i>	Er1 to 4	Parameter write error	
	<i>LOCD</i>	LOCD	Password locked	
	<i>Err.</i>	Err.	VFD reset	
	Warning	<i>OL</i>	OL	Stall protection (over-current)
		<i>oL</i>	oL	Stall protection (over-voltage)
<i>rb</i>		RB	Regenerative brake pre-alarm (not used)	
<i>rH</i>		TH	Electronic thermal relay function pre-alarm	
<i>PS</i>		PS	PU stop	
<i>nr</i>		MT	Maintenance signal output (not used)	
<i>Uv</i>		UV	Under-voltage	
<i>SA</i>		SA	Safety Stop	
Alarm	<i>F_n</i>	FN	Fan alarm	

Table 23: Indicator Messages (Part 2 of 2)

Operation Panel Indication		Name
Fault	<i>E.OC1</i>	E.OC1 Over-current trip during acceleration
	<i>E.OC2</i>	E.OC2 Over-current trip during constant speed
	<i>E.OC3</i>	E.OC3 Over-current trip during deceleration or stop
	<i>E.OV1</i>	E.OV1 Regenerative over-voltage during acceleration
	<i>E.OV2</i>	E.OV2 Regenerative over-voltage trip during constant speed
	<i>E.OV3</i>	E.OV3 Regenerative over-voltage trip during deceleration or stop
	<i>E.THT</i>	E.THT Inverter overload trip (electronic thermal O/L relay function)
	<i>E.THM</i>	E.THM Motor overload trip (electronic thermal O/L relay function)
	<i>E.FIN</i>	E.FIN Heatsink overheat
	<i>E.ILF</i>	E.ILF Input phase loss (not used)
	<i>E.OLT</i>	E.OLT Stall prevention stop
	<i>E. BE</i>	E. BE Brake transistor alarm detection
	<i>E. GF</i>	E.GF Output side earth (ground) fault over-current at start (not used)
	<i>E. LF</i>	E.LF Output phase loss
	<i>E.OHT</i>	E.OHT External thermal relay operation (not used)
	<i>E.PTC</i>	E.PTC PTC thermistor operation (not used)
	<i>E. PE</i>	E.PE Parameter storage device fault (not used)
	<i>E.PUE</i>	E.PUE PU disconnection (not used)
	<i>E. RET</i>	E.RET Retry count excess
	<i>E. S</i>	E.5 CPU fault
	<i>E.CPU</i>	E.CPU
	<i>E.CDO</i>	E.CDO Output current detection value exceeded (not used)
	<i>E. IOH</i>	E.IOH Inrush current limit circuit fault
	<i>E.AIE</i>	E.AIE Analog input fault
<i>E.SAF</i>	E.SAF Safety circuit fault	

Resetting the VFD68 Drive



WARNING: Risk of Personal Injury.

Before you reset the VFD68 Drive, verify that all persons are clear of the controlled equipment. Resetting the VFD68 Drive may immediately start the controlled equipment, and failure to verify that all persons are clear of the controlled equipment before resetting the VFD68 Drive may result in severe personal injury or death.

AVERTISSEMENT: Risque de blessure.

Avant de réinitialiser le VFD68 Drive, assurez-vous qu'aucune personne n'est à proximité de l'équipement. La réinitialisation du VFD68 Drive peut faire redémarrer l'équipement contrôlé immédiatement et le non-respect de cette précaution pourrait entraîner des blessures graves, voire mortelles.

IMPORTANT: To prevent the motor from starting immediately after a fault reset, remove the jumper that connects terminal SD to terminal STF before clearing the reset.

If the motor stops due to a fault, you can reset the VFD by using either of the following two methods.



Reset Option 1

1. Remove the jumper that connects terminal SD to terminal STF before clearing the reset.
2. Using the operation panel, press  to reset the VFD.
3. Go to *Restarting the Motor After It Has Stopped*.

Reset Option 2

1. Remove the jumper that connects terminal SD to terminal STF before clearing the reset.
2. Disconnect power from the drive. After the indicator of the operation panel turns OFF, reinstall the jumper that connects terminal SD to terminal STF.
3. Reconnect power to the drive.



Manually Stopping the Motor

You can stop the motor while the VFD68 Drive is in any mode (PU, EXT, or NET) by pressing . When you press , the drive monitor displays **PS** (PU Stop Warning) and then performs a controlled shutdown of the motor.

Restarting the Motor After It Has Stopped

To restart the motor after a controlled stop, disconnect the supply power from the drive for at least 30 seconds and then reconnect the supply power to the drive.

If it is not easy to disconnect the supply power from the drive, follow these steps:

1. Disconnect the jumper between the SD and STF terminals on the low-voltage terminal blocks.
2. Press . The PU LED lights.
3. Press  two more times. The EXT LED lights.
4. Reconnect the jumper between the SD and STF terminals.

Technical Specifications

VFD68Bxx or VFD68Cxx Variable Frequency Drive (230 or 460 VAC)

Input Power Voltage/Frequency	230 VAC, 50 HZ (208/230 VAC, 60 Hz); 400 VAC, 50 Hz (460 VAC, 60 Hz); Continuous Duty
Output Voltage/Frequency	230 VAC, 50 HZ (208/230 VAC, 60 Hz); 400 VAC, 50 Hz (460 VAC, 60 Hz); Continuous Duty
Input Devices	Johnson Controls/PENN® P499 Electronic Pressure Transducers
PWM Carrier Frequency	Adjustable 0.7 to 15 kHz
Motor Requirements	Three-phase NEMA Design B motors required; Inverter-rated motors recommended
Overload Capacity	150% of ampere rating for 1 minute
Start/Stop	Use STF input to start or stop the motor
Ambient Conditions	Storage: -40 to 65°C (-40 to 149°F), 0 to 95% RH Non-condensing
	Operating: -40 to 50°C (-40 to 122°F), 0 to 95% RH Non-condensing
	Altitude: 1,000 m (3,300 ft) Maximum without derating
Enclosures	UL Type 1 (NEMA) Fan Cooled (230 VAC 1 hp and lower models do not have a fan)
Maximum High Voltage Wire Length	Up to 100 m (328 ft) between the VFD68 Drive and the motor (using the appropriate wire gauge)
Compliance 	North America: cULus Listed, UL 508C, CSA-C22.2 No. 14, File E244421; Industry Canada (IC) Compliant to Canadian ICES-003, Class B limits Europe: CE Mark - Johnson Controls, Inc. declares that this product is in compliance with the essential requirements and other relevant provisions of the Low Voltage Directive and the EMC Directive when an EMC-compliant line filter is attached to the power supply. ¹ Australia: Regulatory Compliance Mark (RCM)
Dimensions (H x W x D)	Minimum: 128 x 68 x 81 mm (5 x 2-11/16 x 3-3/16 in.) Maximum: 150 x 140 x 136 mm (5-15/16 x 5-1/2 x 5-5/16 in.)
Shipping Weight	0.5 to 3.8 kg (1.1 to 4.41 lb)

1. For more information, refer to Appendix 5: EMC Line Filter Selection Chart in the VFD68 Variable Frequency Drive Technical Bulletin (Part No. 24-7664-3051).

European Single Point of Contact:

JOHNSON CONTROLS
WESTENDHOF 3
45143 ESSEN
GERMANY

NA/SA Single Point of Contact:

JOHNSON CONTROLS
507 E MICHIGAN ST
MILWAUKEE WI 53202
USA

APAC Single Point of Contact:

JOHNSON CONTROLS
C/O CONTROLS PRODUCT MANAGEMENT
NO. 22 BLOCK D NEW DISTRICT
WUXI JIANGSU PROVINCE 214142
CHINA



Building Efficiency

507 E. Michigan Street, Milwaukee, WI 53202

Johnson Controls® and PENN® are registered trademarks of Johnson Controls, Inc. in the United States of America and/or other countries. All other trademarks used herein are the property of their respective owners. © Copyright 2016 by Johnson Controls, Inc. All rights reserved.