



BY JOHNSON CONTROLS

SB0114

1209

File In: N/A

SERVICE BULLETIN

Affected Equipment: YPAL MOD A, B, C, and D units

Subject: Rain Water Accumulation in the Unit Top Panel

Issue Date: 12/15/2009 **Withdrawal Date:** N/A

Materials Needed: Noted below

Tools Required: Standard Hand Tools

Warranty: Yes

Revision Notes: N/A

GENERAL

We have found some YPAL MOD A, B, C, and D units with water present in the top panel of the unit. The water can drip from the top panel liner and fall on the supply, exhaust, or return fan VFD's resulting in their failure.

SOLUTION

We identified the root cause of the problem as incorrect construction of the top panel assembly. Changes were made to the production documentation and the roof assembly to make the design less operator dependent. All units built after August of 2009, 2KVM serial number prefix, were produced with these updates.

Not all units will have this problem. To check a suspect unit, drill a ¼ inch hole through the top liner in the blower compartment to check for the presence of water and wet insulation. If there is no evidence of moisture reseal the hole with RTV. If moisture and wet insulation is identified order the repair kit identified in the attached instructions.

WARRANTY

YPAL Field Service Support must be notified before proceeding with the attached procedure. If the unit is still under warranty process a claim through the normal warranty process. If the unit is out of warranty submit a warranty claim under the "Known Documented Defects" policy. Reference this Service Bulletin #SB0114 in the Description section of the submittal. All repairs covered by this letter must be made by JCI Service Personnel.

We will cover up to \$1,600 for this work. The repair will require two people in order to handle the roof panels safely.

Work on this equipment should only be done by properly trained personnel who are qualified to work on this type of equipment. Failure to comply with this requirement could expose the worker, the equipment and the building and its inhabitants to the risk of injury or property damage.

The instructions on this service bulletin are written assuming the individual who will perform this work is a fully trained HVAC & R journeyman or equivalent, certified in refrigerant handling and recovery techniques, and knowledgeable with regard to electrical lock out/tag out procedures. The individual performing this work should be aware of and comply with all national, state and local safety and environmental regulations while carrying out this work. Before attempting to work on any equipment, the individual should be thoroughly familiar with the equipment by reading and understanding the associated service literature applicable to the equipment. If you do not have this literature, you may obtain it by contacting a Johnson Controls Service Office.

Should there be any question concerning any aspect of the tasks outlined in this bulletin, please consult a Johnson Controls Service Office prior to attempting the work. Please be aware that this information may be time sensitive and that Johnson Controls reserves the right to revise this information at any time. Be certain you are working with the latest information.

GENERAL

The purpose of this instruction is to identify the proper procedures to follow to resolve problems on 50 to 105 ton MOD A, B, C, and D YPAL units with water in the top panel insulation.

MATERIALS NEEDED

Factory Supplied

UNIT MODEL	KIT PART NUMBER
50 TO 65 TON STD CABINET	385-01923-001
50 TO 65 TON EXTENDED CABINET	385-01923-002
70 TO 85 TON STD CABINET	385-01923-003
70 TO 85 TON EXTENDED CABINET	385-01923-004
90 TO 105 TON STD CABINET	385-01923-005
90 TO 105 TON EXTENDED CABINET	385-01923-006
106 TO 130 TON STD CABINET	385-01923-007
106 TO 130 TON EXTENDED CABINET	385-01923-008

FIELD SUPPLIED

1. Spray Bottle
2. Isopropyl Alcohol
3. Clean Rags
4. SikaFlex Urethane Caulk (Grainger p/n 4KM87 or Home Depot p/n 271288)

TOOLS

1. 1-inch Putty Knife
2. 4 inch Dry Wall Knife
3. Standard Hand Tools

PROCEDURE

1. Remove power from the unit and follow standard Lock Out/Tag Out procedures.



This procedure will require the use of a ladder to access the top of the unit. Follow proper Johnson Controls PPE requirements based on the height of the unit above the roof decking. Verify the facility owners do not have PPE requirements more stringent than the Johnson Controls requirements.

2. Remove the screws securing the top panel cap rails to the unit top panel. Retain the screws for use during reassembly.
3. Remove the top panel cap rails from the top panel by starting at one side and separating the cap rails from the top panel by pulling up on the cap rail. A one inch wide putty knife can be used to separate the cap rail from the top cover flanges. The top panel cap rails will not be reused.
4. Remove the screws securing the top panels to the unit top rail. Retain the screws for use during reassembly.

5. Start at the condenser end of the unit and remove the first top panel section. Use a 4 inch drywall knife to separate the joint between the top panel sections.
6. Remove the remaining top panel sections.
7. Remove and dispose of the top panel insulation.
8. Use a wet/dry vacuum to remove any water from the top panel inner liners.
9. Use a wet/dry vacuum to extract any water that is encapsulated in the sponge gasket material between the inner top liner and the top rail.
10. Seal all screw holes and other openings between the top inner panels and the interior of the unit from the top of the top panel with SikaFlex Urethane Caulk.
11. Clean the area in Figure 1 prior to the application of the sealing strip with isopropyl alcohol. Use clean rags to wipe the surface clean.

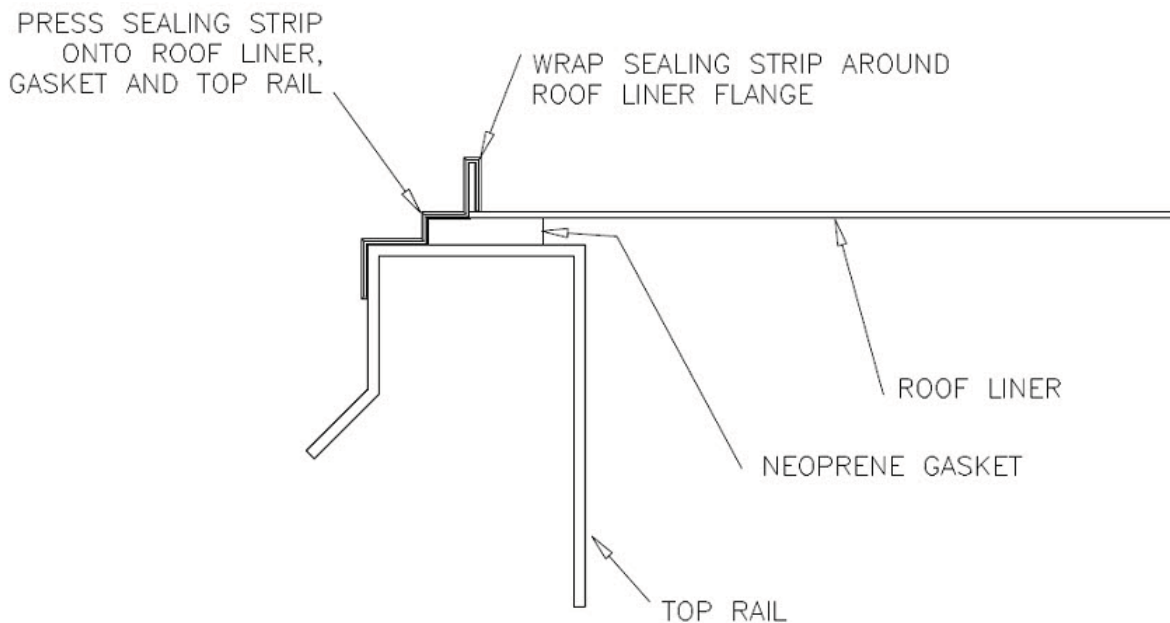
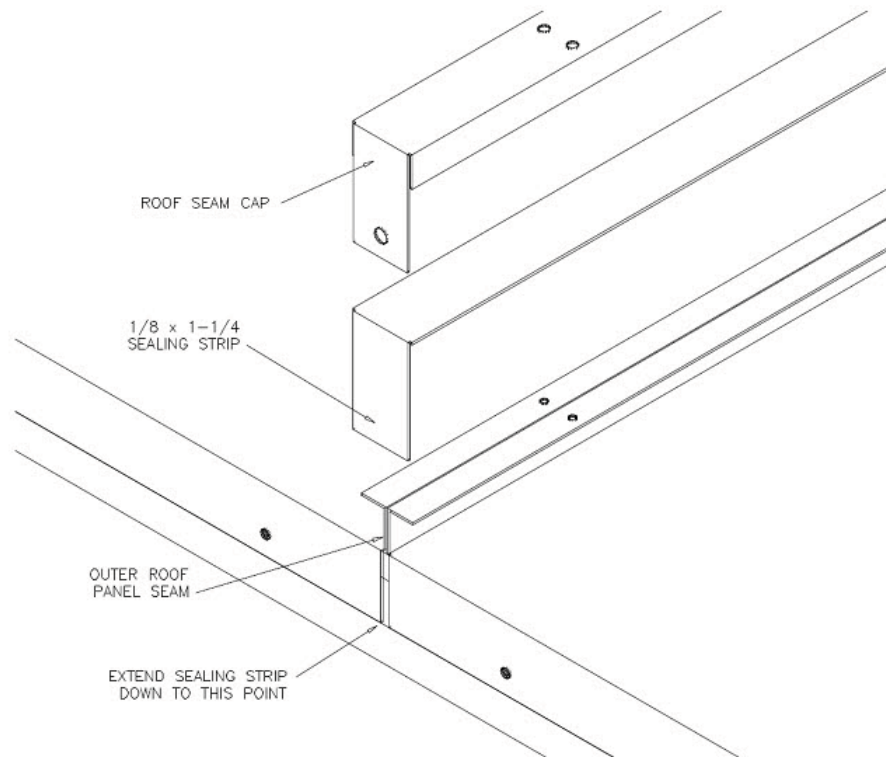

FIGURE 1

12. Apply the sealing strip, as shown in Figure 1 in one continuous length around the perimeter of the unit. When required overlap any joint with a 1 inch overlap.
13. Install replacement insulation making sure the insulation does not extend beyond the outer flange of the top panel inner liner. Make sure the top panel inner liners and center channels are covered by insulation.
14. Reinstall the top panel section starting at one end of the unit and installing one panel at a time. Use the screws removed in step 4 to fasten the top panel to the unit top rail.
15. Apply a continuous strip of double sided tape where two top panel sections butt together. Start at the drip flange on one side of the top rail and run the tape across the top panel and down to the drip edge of the top panel on the other side. Center the tape on the joint between the two panels. See figure 2.

**FIGURE 2**

16. Install the new top panel cap rails using the screws removed in step 2.
17. Remove the Lock Out/Tag Out device installed in step 1. Return power and verify operation of the unit.