

SECTION 5 – SEQUENCE OF OPERATION

COMPRESSOR STAGING

On the Design Level "C" units the Constant Volume (CV), Variable Air Volume (VAV) and FlesSys units all use the same compressor staging sequence.

TABLE 10 – FOUR OR SIX COMPRESSOR LOGIC – STAGING UP

| Stage | Logic |
|-------|---|
| 1 | Compressor 1A or 1B with shortest totalized run time and expired ASCD |
| 2 | Other compressor from System 1 (Wait for ASCD to expire if not expired) |
| 3 | Compressor 2A, 2B, 3A or 3B with shortest totalized run time and expired ASCD |
| 4 | Other compressor from System 2 or 3 with shortest run time and expired ASCD |
| 5 | Other compressor from System 2 or 3 with shortest run time and expired ASCD |
| 6 | Other compressor from System 2 or 3 with shortest run time and expired ASCD |

TABLE 11 – FOUR OR SIX COMPRESSOR LOGIC – STAGING DOWN

| Stage | Logic |
|----------|--|
| 6 to 5 | Compressor from System 2 or 3 with longest run time and expired Min. Run Time. |
| 5 to 4 | Other Compressor from Sys. 2 or 3 with longest run time and expired Min. Run Time. |
| 4 to 3 | Other Compressor from Sys. 2 or 3 with longest run time and expired Min. Run Time. |
| 3 to 2 | Other Compressor from Sys. 2 or 3 with longest run time and expired Min. Run Time. |
| 2 to 1 | Compressor from System 1 with longest run time and expired Min. Run Time. |
| 1 to Off | Last Compressor from System 1 after Min. Run Time has expired. |

Note that ASCD (anti short cycle delay) and Minimum Run Time will take priority above Compressor totalized run time. For example, when turning on the first stage, the control will determine which compressor has the shortest total run time and also read the ASCD timers for each compressor. If the compressor with the shortest total run time has expired its ASCD, then that compressor will be started. If the compressor with the shortest total run time has not expired its ASCD but the other compressor has, then the compressor with the longer run time will be started.

COMPRESSOR AVERAGE RUN TIMES

To increase system reliability, all compressors will be staged up (ON) based on total run time. The compressors with the shortest total run time will always be energized first in an attempt to equalize run time.

SUPPLY FAN OPERATION

Minimum Off Time

The Supply Fan minimum OFF time is as specified in Table 14 under section on Timeouts and Delays.

The Supply Fan will be ON prior to:

- Starting any compressors.
- Turning ON any gas or electric heating stage.
- Opening any heating valve.

Overrun

The Supply Fan will continue to run for 1 minute after all compressors or heating stages turn OFF unless otherwise stated. When in Thermostat operation, the overrun requirement will override the loss of the G input from the Thermostat.

For gas or electric heat, the Supply Fan will continue to run until the SAT is less than 100°F.

CV Operation

For CV operation:

- The Supply Fan will be ON whenever the G input from the Thermostat is present.
- The Supply Fan will stay ON when the G input is no longer present to satisfy the Overrun requirement.
- If the unit is configured to use a space sensor, the Supply Fan will be ON whenever:
 - Heating or cooling is called for.
 - The "*Fan On with Sensor*" parameter is ON and occupancy is indicated.

VAV & Flexsys Operation

For VAV operation:

- The Supply Fan will be ON at the specified output level whenever occupancy is indicated.
- When occupancy is not indicated the Supply Fan will be ON at the specified output level whenever:
 - Unoccupied cooling or heating is called for.
 - The Thermostat G input is present and the *VAV with Thermostat* parameter is ON.
- In the Heating Mode, the Supply Fan will be at 100% output when ON.
- In the Cooling Mode, the Supply Fan will be operated to maintain the *Duct Static Pressure* setpoint when ON.

TIMEOUTS AND DELAYS

Table 14 lists the timeouts and delays that are to apply in all functions unless an exception for a specific function is specified.

TABLE 14 – TIMEOUTS AND DELAYS

| Number | Timeout or Delay | Description |
|--------|---------------------------------|---|
| 1 | *ASCD for cooling | This “minimum OFF time” delay will not allow any compressor to turn on, unless it has been off for 5 minutes, except when ASCD override is ON. |
| 2 | *ASCD for “Cooling SAT Alarm” | This will not allow any compressor to turn ON after an excessive SAT trip has occurred, until it has been off for 3 minutes. |
| 3 | *ASCD for “Heating SAT Alarm” | This will not allow any heat stage to turn ON after an excessive SAT trip has occurred, until it has been off for 5 minutes. |
| 4 | *ASCD for heating | This “minimum OFF time” delay will not allow any heating stage to turn on, unless it has been off for 2 minutes. Exception: Supply Air Tempering = 1 min. |
| 5 | Energy Saver Delay | This is a 1 minute minimum time between turning on compressor stages or heating steps. |
| 6 | Minimum Run Time for Cooling | A minimum run time of 5 minutes will apply to all compressors. |
| 7 | Supply Fan *ASCD | This will not allow the Supply Fan to turn ON unless it has been OFF for 30 seconds. |
| 8 | Exhaust Fan Minimum Run Time | The exhaust fan will have a minimum ON time of 10 seconds. |
| 9 | Exhaust Fan Minimum Off Time | The exhaust fan will have a minimum OFF time of 1 minute. |
| 10 | Delay to allow SAT to stabilize | A 5 minute delay will be used any time a compressor, or a heating stage is turned ON, or OFF, before using the SAT reading for any control decisions. |

*ASCD - Anti Short Cycle Delay

CONSTANT VOLUME SEQUENCE OF OPERATION

Under Constant Volume (CV) operation, the unit will be controlled from one of the following sources in order of priority:

- 7-Wire Thermostat.
- Space Sensor.

The Primary Unit Controller will monitor each source and self-configure to the source available with the highest priority.

Thermostat Control In CV Operation

Under thermostat control, the unit will monitor the G, Y1, Y2, W1, and W2 thermostat inputs and control the unit accordingly. Cooling Operation with Y1 and Y2 thermostat inputs are as follows:

Compressor Staging - ON:

- Y1 Only – Cooling Stage 1 – Both system 1 compressors and one of the System 2 or System 3 compressors on a six compressor unit.
- Y1 and Y2 – Cooling Stage 2 – All of the installed compressor on System 1, 2 and 3 if applicable.
- If Y2 is present without Y1, the unit will stage on Y1 per above and then stage on Y2.

Compressor Staging – OFF:

- Y2 Off – Shut off Cooling Stage 2 - It will shut off one-half of the installed compressor. On a four compressor system it will shut off the System 2 compressors. On a six compressor system it will shut off three of the four System 2 and System 3 compressors.

- Y1 Off – shut off Cooling Stage 1 – All compressor operation will be shut down

Heating Operation with W1 and W2 Inputs

The Primary Unit Controller can be configured for four types of heat, Gas, Electric, Steam, Hot Water. When Gas or Electric is selected, the unit must also be configured for the number of stages. The Hot Water and Steam options use a modulating valve that varies the heating capacity based on the load. A Modulating Gas Heat option is also available. When Modulating Gas Heat is installed, the unit is configured for Hot Water.

- W1 Active Only (Staged Heat) – One half of the total number of stages will be energized See Table 15.
- W1 Active Only (Modulating Heat) – The Primary Unit Controller will modulate the valve based on the temperature difference between the Supply Air Temperature (SAT) and the “Hydro Heat 1ST Stage” set point.
- W1 and W2 Active (Staged Heat) – All the stages will be energized.
- W1 and W2 Active (Modulating Heat) – The Primary Unit Controller will modulate the valve based on the temperature difference between the Supply Air Temperature (SAT) and the “Hydro Heat 2ND Stage” set point.
- W2 Active Only (Staged Heat) – Only the W2 heat stages will be energized. See Table 15
- W2 Active Only (Modulating Heat) – The Primary Unit Controller will modulate the valve based on the temperature difference between the Supply Air Temperature (SAT) and the “Hydro Heat 2ND Stage” set point.

As the Heating Stages are de-energized, or if steps of heat should be dropped due to Excessive SAT (supply air temperature), the steps of heat will be de-energized one at a time. If the unit is not equipped with heat, the control will ignore the W1 and W2 inputs.

Gas or Electric (Stepped) Heating

If the controller is configured for stepped heating, the controller will read the Heat Steps configuration setting to determine the number of heating steps available. Up to six (6) individual heating steps can be available. These steps will be divided into two Heating Stages as shown in Table 15.

TABLE 15 – STAGED HEATING STEPS

| TOTAL # OF STEPS AVAILABLE | # OF STEPS ASSIGNED TO | |
|----------------------------|------------------------|-----------------|
| | HEATING STAGE 1 | HEATING STAGE 2 |
| 1 | 1 | 0 |
| 2 | 1 | 1 |
| 3 | 2 | 1 |
| 4 | 2 | 2 |
| 5 | 3 | 2 |
| 6 | 3 | 3 |

Space Sensor Control (RTD)

Under space sensor control, the Primary Unit Controller will monitor the space temperature via the space sensor inputs and the Occupied input and control the unit accordingly. The use of a space sensor on a constant volume unit requires an unoccupied/occupied signal to the controller. This signal can be received from one of three sources: the hard-wired Unoccupied/Occupied input, internal scheduling via a Network (BAS), or from a roof link controller. The unoccupied/occupied signal determines what programmed space temperature setpoint to maintain in the controlled space.

For this option to function the configuration setting Space Sensor Enable must be set to ON and the sensor must be reliable. During this mode of operation, if the space sensor becomes unreliable, a fault will be generated. With this, the unit will shut down unless a RAT (return air temperature) sensor is enabled and reliable. If a RAT sensor is present, the unit will monitor the Return Air Temperature for unit control decisions. If the RAT sensor then becomes unreliable, the unit will be shut down.

Types of Space Sensors

No Sensor – The configuration setting, "Space Sensor Enable", Must be selected OFF. The Control will only operate the unit from the Thermostat inputs or from a network (BAS).

Sensor Only – This Sensor only has a RTD in it for unit operation.

Sensor with Unoccupied Override Button – This Sensor has a RTD and an Override button that shorts the Sensor when pushed. After the Override button has been pushed for a minimum of one second the unit will go into the Unoccupied Override mode for the Unoccupied Override Time . The Override mode is cleared if the unit goes Occupied during this Override mode.

Sensor with Space Setpoint Adjust – This Sensor has a slider potentiometer on it that represents (as a default) $\pm 3^{\circ}\text{F}$ adjustment to the Space Setpoint. The Space Setpoint Offset Setpoint specifies the amount of \pm adjustment, in range from 0°F to 5°F .

Sensor w/ Space Setpoint Adjust and Unoccupied Override Button – This Sensor has a slider potentiometer and an Unoccupied Override button. Both functions operate as described above.

Cooling Operation with a Space Sensor

For cooling operation, the space temperature will be controlled to either the:

- Unoccupied Cooling Setpoint or the
- Occupied Cooling Setpoint based on the Occupied/Unoccupied state of the unit (i.e. Occ/Unocc Input, or Internal Scheduling).

Control Algorithm For Space Sensor Cooling – Economizer Not Suitable

The Space Sensor Cooling control algorithm is as illustrated in Figure 22.

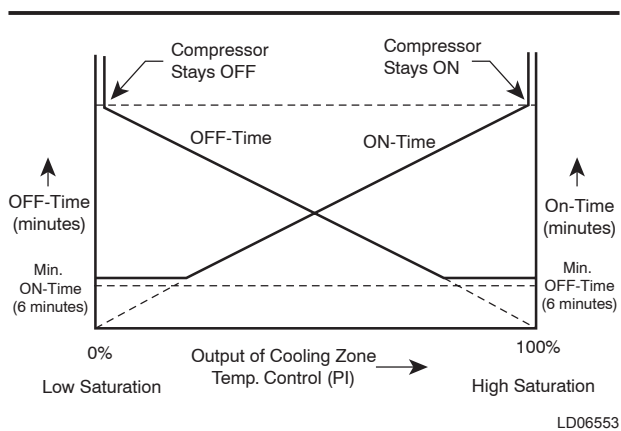

FIG. 22 – CV SPACE SENSOR COOLING ALGORITHM - ECONOMIZER NOT SUITABLE

- A direct acting, proportional – integral space temperature controller generates a 0 – 100% output signal that responds to space cooling demand.
- The output of the controller is used to calculate on and off time of the compressor most recently started based on the calculation method in Figure 22.
- PI gain values are to be determined by such that all compressors are on within 28 minutes with a 10°F space temperature error; or 42 minutes for a 6-compressor system with a 10°F space temp. error.
- When the duty cycle reaches 100% (the PI algorithm reaches a “High Saturation state” and a saturation time delay expires), the modulated compressor stops cycling and remains on.
- An additional compressor is staged every time the space control PI algorithm reaches a High Saturation state and a programmed saturation time delay expires.
- A compressor is destaged when the PI algorithm reaches a Low Saturation state and a programmed saturation time delay expires.

Control Algorithm For Space Sensor Cooling - Economizer Suitable

In CV cooling operation with a space sensor and when free cooling is available (“economizer suitable”), the SAT is controlled by the economizer control algorithm (see page 53; Economizer Operation). The control algorithm is shown in Figure 23 (see section on Economizer Operation for a more specific explanation on economizer operation).

5

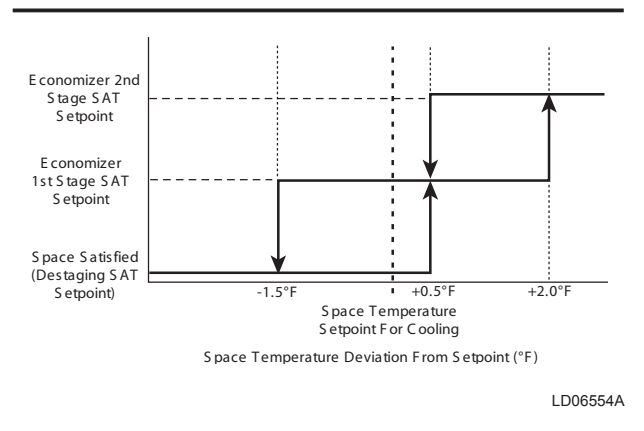

FIG. 23 – CV SPACE SENSOR COOLING ALGORITHM - ECONOMIZER SUITABLE

When the space temperature is 1.5°F or more less than the Economizer 1st stage or Economizer 2nd Stage set point, destaging compressors is accomplished by temporarily requesting an SAT setpoint of 90°F. This setpoint assures that there is no need for compressors even at the highest outdoor air temperature and/or enthalpies.

Note that the destaging process still occurs in cooling state, so there is no possibility of heating being activated due to the temporarily high SAT setpoint, or due to space temperature dropping below its cooling setpoint and towards space heating setpoint.

Staging of Compressors When Exiting Economizer Mode

This situation occurs when one, or more compressors are running in the economizer mode, and free cooling becomes unavailable. The sensor control mode changes – sensor algorithm is no longer selecting the active economizer SAT setpoints, but now is used to directly control the compressors. The control mode changeover process involves turning off the compressors that were running during the economizer operation, and then turning back on the compressors needed during mechanical cooling only. The compressors will continue to operate until the minimum run time criteria has been met.

Heating Operation With a Space Sensor

For Heating operation, the space temperature will be controlled to either the Unoccupied Heating Setpoint or the Occupied Heating Setpoint based on the Occupied/Unoccupied state of the unit (i.e. Occ/Unocc Input, or Internal Scheduling).

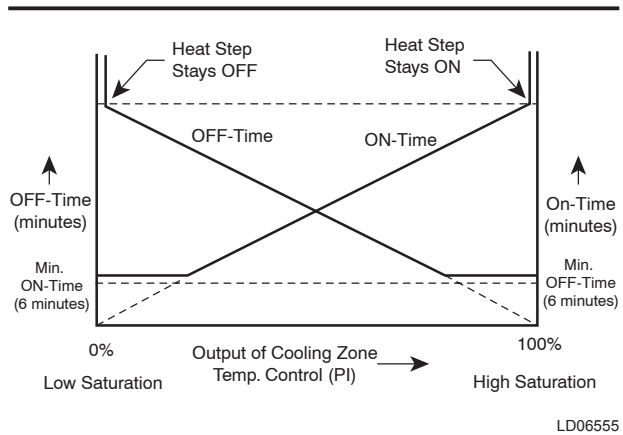

FIG. 24 – CV SPACE SENSOR STEPPED HEAT ALGORITHM

Control Algorithm For Space Sensor Stepped Heat

- The Space Sensor Stepped Heat control algorithm is as illustrated in Figure 22. The controller will read the number of Heat Steps parameter to determine the heat steps available. Heat steps will be used in number sequence.
- A direct acting, proportional – integral space temperature controller generates a 0 – 100% output signal that responds to space heating demand.
- The output of the controller is used to calculate on and off time of the heat step most recently started based on the calculation method in Figure 22.
- PI gain values are to be determined by such that all heating steps are on within 42 minutes with a 10°F space temperature error.
- When the duty cycle reaches 100% (the PI algorithm reaches a “High Saturation state” and a saturation time delay expires), the modulated heating step stops cycling and remains on.
- An additional heating step is started every time the space control PI algorithm reaches a high saturation state and a programmed saturation time delay expires.
- A heating step is stopped when the PI algorithm reaches a Low Saturation state and a programmed saturation time delay expires.

Control Algorithm For Space Sensor Hydronic Heat

In CV heating operation using hydronic heat, the SAT is controlled by algorithm as shown in Figure 23.

Table 16 details the modes of CV operation and provides an overview of the control methods in all modes.

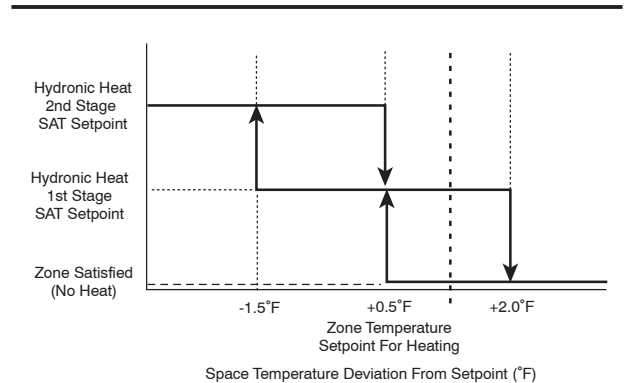

FIG. 25 – CV SPACE SENSOR HYDRONIC HEAT ALGORITHM

LD06556

TABLE 16 – CV (CONSTANT VOLUME) MODES OF OPERATION

| Control | Heating | | Cooling | |
|---------------------|---|---|---|--|
| | Occupied | Unoccupied | Occupied | Unoccupied |
| Thermostat | <p>Controller Occupied input is ON (energized by 'stat occ. output, or by an external command). 'stat uses its programmed occupied htg. Setpoint. Supply fan controlled by 'stat's G output. Economizer damper at programmed min. position. 'stat W1, W2 outputs control heating stages 1 and 2. If hydronic heat or modulating gas heat, 'stat W1,W2 outputs select programmed "Hydro heat 1st and 2nd stage Setpoints</p> | <p>Controller Occupied input is OFF (deenergized by 'stat occ. output, or by an external command). Economizer damper is at 0% Control is same as occupied heating, except 'stat uses its programmed unoccupied heating setpoint.</p> | <p>Controller Occupied input is ON (energized by 'stat occ. output, or by an external command). 'stat uses its programmed occupied clg. setpoint. Supply fan controlled by 'stat's G output Economizer damper at programmed min. position, may modulate open if free cooling is being used. Mechanical cooling mode: 'stat Y1, Y2 outputs control stage 1 and 2 compressors Economizer mode: 'stat Y1, Y2 outputs select High and Low programmed Economizer SAT setpoints, SAT controlled by economizer control algorithm.</p> | <p>Controller Occupied input is OFF (deenergized by 'stat occ. output, or by an external command). Economizer damper is at 0% (damper may modulate open if free cooling is being used). Control is same as occupied cooling, except 'stat uses its programmed unoccupied cooling setpoint.</p> |
| Space Sensor | <p>Controller Occupied input is ON (energized by an external command). Space temperature is controlled to a programmed occupied htg. setpoint. For supply fan, setting of the parameter "Fan ON mode with the Sensor Option" determines if the supply fan is ON continuously, or is in "Auto" mode (i.e. goes off when space is satisfied). Economizer damper at programmed min. position Heating is controlled by a PI algorithm that controls staging of heat stages and modulates duty cycle of the highest numbered running heating stage. If hydronic heat or modulating gas heat, space control algorithm selects programmed "Hydro Heat 1st Stage SAT Setpoint" and "Hydronic Heat 2nd Stage SAT Setpoint"</p> | <p>Controller Occupied input is OFF (deenergized by an external command). Economizer damper is at 0% Supply fan is in "Auto" mode (i.e. goes off when space is satisfied). Control is same as occupied heating, except space temperature is controlled to a programmed unoccupied heating setpoint.</p> | <p>Controller Occupied input is ON (energized by an external command). Space temperature is controlled to a programmed occupied clg. setpoint. For supply fan, setting of the parameter "Fan ON mode with the Sensor Option" determines if the supply fan is ON continuously, or is in "Auto" mode (i.e. goes off when space is satisfied). Economizer damper at programmed min. position, may modulate open if free cooling is being used. Mechanical cooling mode: Cooling is controlled by a PI algorithm that controls compressor staging and modulates duty cycle of the highest numbered running compressor. Economizer mode: Space control algorithm selects High and Low programmed Economizer SAT setpoints, SAT controlled by economizer control algorithm.</p> | <p>Controller Occupied input is OFF (deenergized by an external command). Economizer damper is at 0% (damper may modulate open if free cooling is being used). Supply fan is in "Auto" mode (i.e. goes off when space is satisfied). Control is same as occupied cooling with a space sensor, except space temperature is controlled to a programmed unoccupied clg. setpoint.</p> |

VARIABLE AIR VOLUME SEQUENCE OF OPERATION

Under Variable Air Volume Operation, the unit will be controlled from one of two sources:

- 7-Wire Thermostat
- Space Sensor

In addition to the two control methods, a VAV configured unit can also operate “stand-alone” with the only direct control being the Occupied/Unoccupied signal. The method of control is as selected as described in the following sections.

VAV Operation With a Thermostat

When “*VAV with Thermostat*” parameter is set to ON, a Thermostat is used for SAT reset control.

If the Thermostat is not available, the Primary Unit Controller will self-configure to Standalone VAV operation

VAV Operation With a Space Sensor

A Space Sensor is used for control when:

- The *VAV with Thermostat* parameter is OFF, and:
 - A Space Sensor is available and the “*Space Sensor Enable*” parameter is ON.
- If a Space Sensor is not available, the controller will self-configure to Standalone VAV operation.

Standalone VAV Operation

Standalone VAV operation is used by the control when:

- The *VAV with Thermostat* parameter is OFF, and
- No Space Sensor is available.

VAV Operating Modes

VAV operating modes have the following common functions:

- For heating, the Heating Mode Enable parameter must be ON.
- For cooling, the Cooling Mode Enable parameter must be ON.
 - Cooling (compressor) stages are controlled as described in the following sections.
 - The SAT control algorithm for cooling is described in the following sections.

- The Supply Fan is:
 - Controlled as described in the Fan.
 - Controlled to maintain the Duct Static Pressure setpoint when cooling or heating is ON.
 - ON and controlled for heating or cooling when the Thermostat G output is ON.
 - Ramped up to its operation condition using its variable output control when turned ON.
 - OFF when heating or cooling is OFF and occupancy is UNOCCUPIED.
 - Optionally controlled ON and OFF by a BAS input when occupancy is UNOCCUPIED.
- For Economizer Operation, the *Economizer Installed* parameter must be ON and the *Economizer Enable* parameter must be ON. The economizer is:
 - Closed for all unoccupied heating.
 - At the minimum position for occupied heating.
 - At minimum for occupied cooling when economizer is not available.
 - Closed for unoccupied cooling when economizer is not available.
 - At the economizer algorithm determined position for cooling with economizer available.

Unoccupied Heating With A Thermostat

The heating control is as described for “Occupied Heating With A Thermostat” and the general operating conditions.

Occupied Cooling With A Thermostat

- The thermostat Y1 and Y2 outputs control SAT to:
 - Y1 = OFF, Y2 = OFF – No cooling
 - Y1 = ON, Y2 = OFF - Cooling to “*VAV Cool High Temp Setpoint*”.
 - Y1 = ON, Y2 = ON - Cooling to “*VAV Cool Low Temp Setpoint*”.
 - Y1 = OFF, Y2 = ON - Cooling to “*VAV Cool Low Temp Setpoint*”.

Unoccupied Cooling With A Thermostat

The cooling control is as described for Occupied Cooling With A Thermostat and the general operating conditions.

Occupied Heating With A Space Sensor

- The programmable parameter "*VAV with Thermostat*" is OFF, and a space sensor is available and the "*Space Sensor Enable*" parameter is ON.
- The programmable parameter enable setting "*Occupied Heating*" must be set to ON to enable the Occupied Heating With A Space Sensor function.
- The stepped heating control algorithm is:
 - Turned ON when the space temperature is less than the "*VAV Sp for SAT Reset*" by 20F
 - Monitors the return air temperature and controls the unit between the "*Warm-Up RAT*" and the "*Warm-Up RAT*" minus 2 F.

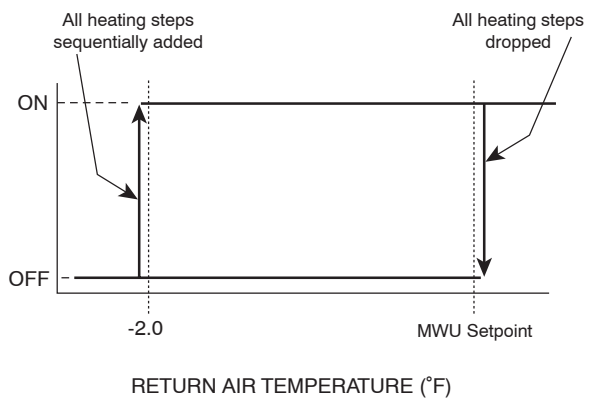

LD06557

FIG. 26 – VAV OCCUPIED HEATING TO MAINTAIN RAT AND MORNING WARM UP

- Turned OFF when the space temperature is greater than ("*VAV SP for SAT Reset*" - 1.5°F) or the RAT reaches setpoint.
- Figure 30 illustrates the algorithm for occupied heating required.
- For hydronic heating:
 - The SAT is controlled to the 2nd Stage Hydronic Heat Setpoint.
 - The Heat 1 output of the controller is set to control HIGH during heating.

Unoccupied Heating With A Space Sensor

- The programmable parameter "*VAV Operation with Thermostat*" must be set to OFF and Space Sensor signal must be reliable.
- The programmable parameter "*VAV Occupied Heating*" must be set to ON to enable the Occupied Heating With A Space Sensor function.

- Both the space temperature and the RAT must be 2°F below their setpoints.
- The space temperature is controlled to the Unoccupied Heating Setpoint using the algorithm illustrated in Figure 27.

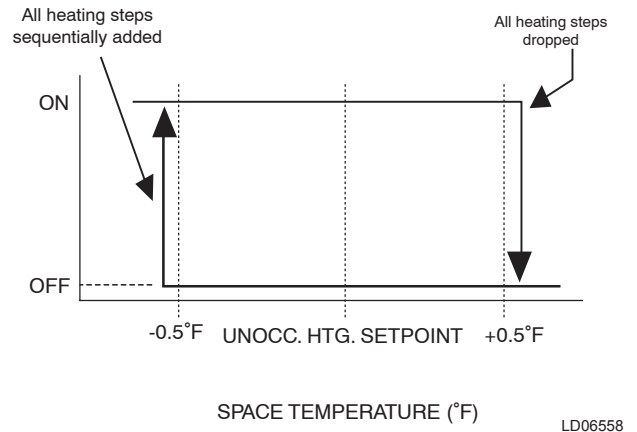

LD06558

FIG. 27 – VAV UNOCCUPIED STEPPED HEATING-TEMPERATURE CONTROL

- For hydronic heating:
 - The SAT is controlled to the 2nd Stage Hydronic Heat Setpoint.
 - The Heat 1 output of the controller is set to control HIGH during heating.

5

Occupied Cooling With A Space Sensor

- The programmable parameter *VAV Operation with Thermostat* must be set to OFF and Space Sensor signal must be reliable.
- The SAT setpoint for cooling is the "*VAV Cool Low Temp*" or "*VAV Cool High Temp*" through comparison of the space temperature and the "*VAV SP for SAT Reset*" as shown in Figure 30.

Unoccupied Cooling With A Space Sensor

- The programmable parameter *VAV Operation with Thermostat* must be set to OFF and Space Sensor signal must be reliable.
- Cooling is called for according to the algorithm illustrated in Figure 28.
 - The SAT setpoint for unoccupied cooling is the VAV Cool High Temperature Setpoint.

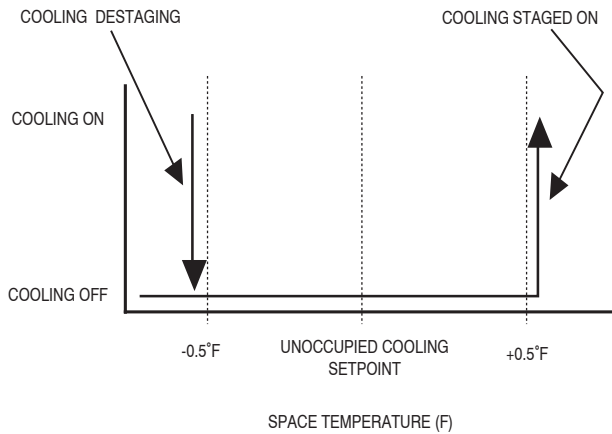

FIG. 28 – VAV UNOCCUPIED COOLING TEMPERATURE CONTROL

LD06559

- Non-Economizer Operation or Economizer Operation when economizer is not suitable is as described in Figure 29.

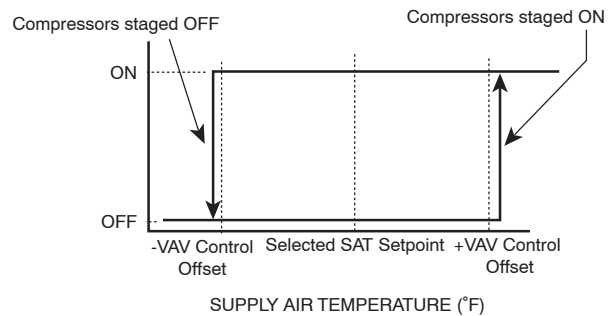

FIG. 29 – COMPRESSOR STAGING FOR VAV COOLING

LD06560

Occupied Heating In Standalone Operation

The following conditions must be met to initiate heating operation:

- A RAT (Return Air Sensor) must be installed in the unit and the "RAT Sensor Enable" must be ON.
- The RAT must be 2 degrees less than the "Warm-up RAT" setting.

Unoccupied Heating In Standalone Operation

- In this mode, the unit remains shut down, unoccupied heating is never used.

Occupied Cooling In Standalone Operation

- The programmable parameter *VAV with Thermostat* must be set to OFF.
- Space Sensor signal must be unreliable or not detected.
- The SAT setpoint for occupied standalone cooling when the economizer is active is "VAV Cool High Temp" and when the economizer is not active the SAT setpoint is "VAV Cool Low Temp".

Unoccupied Cooling In Standalone Operation

- In this mode, the unit remains shut down, unoccupied cooling is never used.

SAT Control Algorithm in VAV Cooling

This section describes the control of compressors to maintain the SAT setpoint for:

- Economizer Operation when mechanical cooling is required to maintain the SAT setpoint
- or

The setpoint is as determined for the space temperature condition and is either the "VAV Cool High Temp" or the "VAV Cool Low Temp" setting.

The SAT will be controlled at the above setpoints +/- "VAV Control Offset".

The compressors will stage ON after the SAT has been greater than (SAT Setpoint + VAV Control Offset) for 5 minutes.

Compressors will be staged OFF individually when the SAT drops below the (SAT Setpoint - VAV Control Offset).

Supply Duct Static Pressure Control Algorithm

The Supply Duct Static pressure will be controlled to the duct static pressure setpoint. An appropriate PI closed loop control algorithm will be used to control the supply duct static pressure by modulating the supply fan VFD.

Occupied VAV Heating / Cooling Control Algorithm With A Space Sensor

In the occupied mode, the Space Sensor will compare the space temperature to the programmed "VAV SP for SAT Reset" and request heating, or cooling, using the following control algorithm (Figure 30):

- The transition from cooling to occupied heating occurs at 2°F below the "VAV SP for SAT Reset"
- The reverse transition at 1.5°F below the "VAV SP for SAT reset". There is no "satisfied", or "idle" state of the unit between cooling and occupied heating.

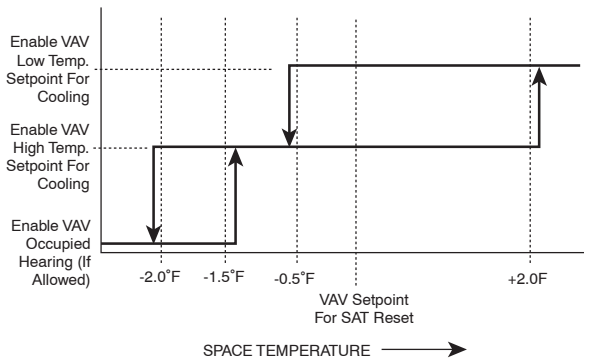

LD06561

FIG. 30 – OCCUPIED HEATING AND COOLING SETPOINT SELECTION ALGORITHM

Morning Warm Up

Morning Warm Up operation is carried out when:

- The *Morning Warm Up* parameter is ON.
- The *Internal Clock/Schedule* parameter is ON.
- Occupancy is scheduled for the current day.
- Warm up command is received from BAS.

The Morning Warm Up start time will be 60 minutes prior to scheduled occupancy, or BAS initiates the morning warm-up.

When started, the Morning Warm Up operation is as follows:

- Close economizer.
- Turn the Supply Fan ON and operate for 2 minutes before beginning temperature control.
- If the RAT is 2 degrees less than the Morning Warm Up setpoint, the Primary Unit Controller will energize the heat relays and bring on all stages after one minute.
- For stepped heating - Control to maintain the RAT to the Morning Warm Up Setpoint using the algorithm illustrated in Figure 26.
- For Hydronic heating - The SAT is controlled to the 2nd Stage Hydro Heat Setpoint.

Morning Warm Up operation will end when:

- An occupancy (space is occupied) input is received from the controller input.
- The scheduled occupancy time occurs.

- The Morning Warm Up operation times out based on the "*Max Warm Up Time*" parameter if warm up signal is controlled by a BAS signal.

Supply Air Tempering

VAV Supply Air Tempering operation requires the following:

- Economizer – ON
- Unit is equipped with electric, gas, steam or hydronic heat
- Heat Enable - ON
- Economizer Enable – ON
- Conditions are suitable for Economizer operation
- Supply Air Tempering Enable – ON
- All compressors – OFF

Supply Air Tempering is a continuation of the VAV cooling operation when the Outdoor Air Temperature is below the SAT setpoint, where heating is used to maintain ventilation operation.

Supply Air Tempering With Proportional Heat

If the unit is equipped with proportional heat, Hot Water, Steam, or Modulating Gas, the control will provide Supply Air Tempering:

- When the SAT falls below the (SAT setpoint – 10°F) for 10 minutes.
- The control will control the Heating Valve analog output to maintain the current "*VAV Cool High Temp*" Setpoint.

The control will end Supply Air Tempering operation and begin Cooling operation when the SAT rises to 4°F above the "*VAV Cool High Temp*" setpoint.

Supply Air Tempering With Staged Heat

If the unit is equipped with stepped heat (electric or gas), the heat stages will be duty cycled to maintain SAT setpoint.

The duty cycle for the heat steps will be:

- A 10-minute period;
- A minimum time of 2 minutes ON;
- A minimum time of 1 minute OFF.

Table 17 details the modes of VAV operation and provides an overview of the control methods in all modes.

TABLE 17 – VAV MODES OF OPERATION

| Control | Heating | | Cooling | |
|------------------------------------|--|---|---|---|
| | Occupied | Unoccupied | Occupied | Unoccupied |
| Thermostat | 'stat uses its programmed occupied htg. Setpoint, controls SAT to "no heating" (W1=OFF), or "full heating (W1=ON). During heating, supply fan meets duct static requirements. If hydronic heat, SAT controlled to 2nd stage hydronic heat setpoint. | Same as occupied heating, except 'stat uses its programmed unoccupied heating setpoint, 'stat generates "unoccupied" output that overrides ODA damper min. position to 0%. During heating, supply fan at 100%. | 'stat uses its programmed occupied clg. setpoint, 'stat Y1, Y2 outputs control SAT to "no cooling" (Y1=OFF), cooling to "VAV Cool High Temp SAT setpoint" (Y1=ON) and cooling to "VAV Cool Low Temp SAT setpoint" (Y1=ON, Y2=ON). ODA damper at min. position (damper may modulate open if free cooling is being used) Supply fan controlled during cooling by supply duct static, supply fan uses a "soft start." | Same as occupied cooling, except 'stat uses its programmed unoccupied cooling setpoint, 'stat generates "unoccupied" output that overrides ODA damper min. position to 0% (damper may modulate open if free cooling is being used). Supply fan controlled during cooling by supply duct static. |
| Network Communicated Sensor | Similar to thermostat operation above, 'stat W1 signal is replaced by a network command. | Similar to thermostat operation above, 'stat W1 signal is replaced by a network command. Network supplies an "unoccupied" command. | Similar to thermostat operation above, 'stat signals are replaced by network commands requesting cooling to High SAT setpoint (Stage 1), or to Low SAT setpoint (Stage 2). | Similar to thermostat operation above, 'stat signals are replaced by network commands requesting cooling to High SAT setpoint (Stage 1), or to Low SAT setpoint (Stage 2), network supplies an "unoccupied" command. |
| Space Sensor | Control algorithm is same as for Morning WarmUp cycle. RAT is controlled to a programmed setpoint w/ 2°F deadband when space temperature drops 2°F below "VAV setpoint for SAT reset". During heating, supply fan meets duct static requirements. If hydronic heat, SAT controlled to 2nd stage hydro heat setpoint. Both space and RAT must be below setpoints. | An external "unoccupied" signal initiates this mode. Space temperature is controlled to a programmed unoccupied htg. Setpoint by cycling unit On/Off. Full heating (all stages) is ON when space temperature drops 0.3°F below the setpoint, OFF when temperature is 0.1°F or less below the setpoint for at least 60 sec. During heating, supply fan at 100%. If hydronic heat, SAT controlled to 2nd stage hydronic heat setpoint. | Cooling SAT setpoint is reset by space temperature vs. "VAV setpoint for SAT reset". "VAV Cool Low Temp" setpoint used if space temperature 2°F above the reset setpoint, "VAV Cool High Temp" setpoint if space temperature 0.5°F below the reset setpoint. ODA damper at min. position (damper may modulate open if free cooling is being used) Supply fan controlled during cooling by supply duct static, supply fan uses a "soft start". | An external "unoccupied" signal initiates this mode, overrides ODA damper min. position to 0% (damper may modulate open if free cooling is being used). Space temperature is controlled to programmed unoccupied clg. Setpoint by cycling unit On/Off. When space temperature increases 0.3°F above the setpoint, cooling runs at programmed High SAT setpoint, when temperature is 0.1°F or less above the setpoint for at least 60 sec, unit turns OFF. During cooling, supply fan is controlled by supply duct static, supply fan uses a "soft start". |
| None (standalone) | RAT must be below setpoint for 10 minutes. | An external "unoccupied" signal initiates this mode, unit shuts down. | SAT is controlled to the "VAV Cool High Temp" if the economizer is active or to the "VAV Cool Low Temp" if the economizer is not active. Supply fan is always running and controlled by the duct static. | An external "unoccupied" signal initiates this mode, unit shuts down. |

ECONOMIZER OPERATION

Economizer operation is described in the following sections. A final section within Economizer operation description is on Economizer Loading. Economizer Loading is a variation on the Economizer operation. Its function is to override the economizer to minimize SAT swings resulting from turning cooling/heating stages on and off.

Criteria for Economizer Operation

Economizer operation will be used for control when:

- Economizer - ON
- Economizer Enable - ON
- Required sensors are reliable
- Outside air conditions are suitable per criteria discussed in the following sections

Criteria for Economizer Suitable Decision

There are three different methods of Economizer Operation:

- **Differential Enthalpy Method:** will be self-configured and used when sensors for Outdoor Air temperature, Outdoor Air humidity, Return Air temperature, and Return Air humidity are all installed and reliable. This method is the highest priority when sensors are available.
- **Outside Enthalpy Method:** will be self-configured and used only when differential enthalpy method is not available, and sensors for Outdoor Air temperature and Outdoor Air humidity are installed and reliable.
- **Outside Temperature Method:** will be self-configured and used only when differential enthalpy or outside enthalpy methods are not available, and sensor for Outside Air temperature is installed and reliable.

Economizer Suitable Calculations

Outside Temperature Method:

Economizer will be suitable when $OAT < (SAT \text{ setpoint} + 10^{\circ}F)$. A $2^{\circ}F$ hysteresis about the $(SAT \text{ setpoint} + 10^{\circ}F)$ will be used. The $10^{\circ}F$ offset represents the highest outdoor air temperature that the DX cooling can reliably reduce to the SAT setpoint.

Outside Enthalpy Method:

Economizer will be suitable when $OA \text{ Enthalpy} < \text{Outside Enthalpy Number}$ parameter value and $OAT < (SAT \text{ setpoint} + 10^{\circ}F)$. A $2^{\circ}F$ hysteresis about the $(SAT \text{ setpoint} + 10^{\circ}F)$ will be used. A 1 BTU/LB hysteresis about the *Outside Enthalpy Number* will be used.

Differential Enthalpy Method:

Economizer will be suitable when $OA \text{ Enthalpy} < RA \text{ Enthalpy}$ and $OAT < (SAT \text{ setpoint} + 10^{\circ}F)$. A $2^{\circ}F$ hysteresis about the $(SAT \text{ setpoint} + 10^{\circ}F)$ will be used. A 1 BTU/LB hysteresis about the RA Enthalpy will be used.

SAT Setpoints Used During Cooling With Economizer Operation

Under Economizer Operation, the following SAT setpoints will be used:

CV Cooling Mode:

- With a call for first stage cooling, the *Economizer First Stage Setpoint* value will be used as the Economizer SAT setpoint.
- With a call for second stage cooling, *Economizer Second Stage Setpoint* value will be used as the Economizer SAT setpoint.

VAV Cooling Mode:

- With a call for first stage cooling, the "*VAV Cool High Temp*" setpoint will be used as the Economizer SAT setpoint
- With a call for second stage cooling, the "*VAV Cool Low Temp*" setpoint will be used as the Economizer SAT setpoint

SAT control with Economizer

The economizer control will be based on a PI, direct acting algorithm. If economizer is "suitable" (free cooling is available) and cooling is required (the unit is not in satisfied state), the algorithm will be active and modulate the economizer position (outside air and return air dampers) in order to control SAT to the SAT setpoint. If the economizer is not suitable, the Economizer Operation is no longer used and control reverts to the appropriate economizer not suitable mode of operation.

Control of Compressors with Economizer

In Economizer Operation, compressors are started only when the specified SAT setpoint cannot be achieved through outside air and return air mixing. Compressors will be turned ON / OFF individually.

Turning ON of Compressor #1:

If no compressors are ON, and the economizer controller is saturated high (i.e. the economizer is 100% open and can no longer maintain the SAT setpoint by just free cooling),

- Calculate a temporary SAT setpoint as (SAT setpoint) T = (SAT setpoint + 5°F);
- When the SAT is $0.5^{\circ}\text{F} < (\text{SAT Setpoint}) T$, turn ON compressor #1;
- Resume SAT control at SAT setpoint.

This is done in order to read and store the SAT temperature differential (drop) due to turning on compressor #1, while assuring that turning it on will not drop the SAT below compressor #1 trip point (where the Excessive SAT control would turn it off again). The same staging sequence is used for the remaining compressors.

Turning on compressors #2 through #6:

If the economizer controller is saturated High (i.e. the economizer is 100% open while one or more compressors are running and the control can no longer maintain the SAT setpoint requested by the space control),

- Calculate a temporary SAT setpoint as (SAT setpoint) T = (SAT setpoint + 5°F);
- When the SAT is $0.5^{\circ}\text{F} < (\text{SAT Setpoint}) T$, turn ON compressor #N;
- Resume SAT control at SAT setpoint.

Turning Compressors Off

Compressors are turned OFF as described in the respective sections for CV and VAV cooling operation with economizer suitable.

Compressor Control When Exiting Cooling Lockout on OAT

A situation may arise when in Economizer Mode and one or more compressors are required in addition to full available free cooling in order to maintain the SAT setpoint, but "Cool Lockout OAT" prevents the compressors' use. This situation may arise when the SAT setpoint is set very close to, or even below, the temperature set for Cooling Lockout on OAT – a relatively unusual case. If the OAT then increases above the Cooling Lockout

on OAT parameter value while the call for several compressors exists, the compressors in this case (and only in this case) will turn ON simultaneously.

Economizer Loading Operation

Economizer Loading Operation will be used when:

- Economizer - ON
- Economizer Enable - ON
- Economizer Loading to Control SAT is ON (SAT ECONO LOADING = ON)
- Conditions for Economizer Operation are not suitable
- Required sensors are reliable

This is a programmable option. The user has the ability to turn this function off. It is automatically disabled if the unit does not use an economizer. The on/off programming choice is common to both cooling and heating. The default setting is ON. This "Economizer Loading" function is used only outside the normal Economizer operation.

See also corresponding description in the section on Controlling Excessive SAT for cooling.

Economizer Loading Option In Cooling/Heating

This feature should not be used and the parameter "SAT Econo Loading" should always be set to OFF

VENTILATION OPTION OPERATION

The 50-105 ton eco² rooftop units support several different ventilation options including true Outside Airflow measurement and control. Each option will be controlled differently, depending upon what equipment is installed and how the unit is configured. For any Ventilation option operation, the unit must be configured for Economizer Operation. The ventilation options are described as follows:

Fixed Minimum OA Damper Position

This is the most common approach to ventilation control used with air handling equipment today. With this approach, the OA and RA dampers are mechanically linked together such that when the OA damper is open, the RA damper is closed, and vice versa. The sequence of operation for a fixed minimum position system simply controls the OA damper open to a fixed minimum position during the occupied mode of operation.

The fixed minimum position is set by adjusting the mechanical stops on the damper actuator.

Simply opening the OA damper to a fixed minimum position can be quite effective for bringing in a fixed volume of outside air with Constant Volume (CV) equipment. However, with Variable Air Volume (VAV) equipment, the amount of outside air brought into the air handler varies because the Supply Fan speed and total system air volume varies.

To compensate for VAV equipment, a minimum position reset scheme will be implemented as follows:

The two Unit Setup parameters "OAD Damper Position #1" and "OAD Damper Position #2" will be used to indicate two minimum positions of the OA damper. Both OAD Min Position settings will be used to linearly reset the minimum position of the OA Damper based on the output to the VFD. "OAD Damper Position #1" will indicate the Minimum Position of the OA Damper when the output to the VFD is at 100% (10 VDC). "OAD Damper Position #2" will indicate the Minimum Position of the OA Damper when the output to the VFD is at 50% (5VDC).

Figure 31 indicates how this algorithm will function:

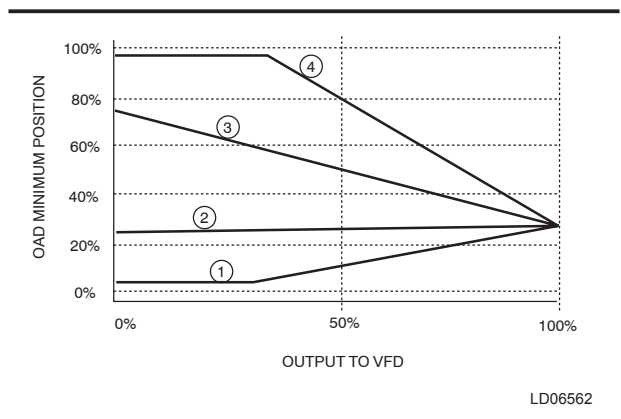

| CURVE | OAD MIN. POSITION #1 | OAD MIN. POSITION #2 |
|-------|----------------------|----------------------|
| 1 | 25% | 10% |
| 2 | | 25% |
| 3 | | 50% |
| 4 | | 80% |

Note:
For units configured for Constant Volume Operation, the OAD Min Position #2 setting will be ignored and only OAD Min Position #1 will be used to set the Minimum Position of the outside air damper.

FIG. 31 – OAD MINIMUM POSITION RESET

Outdoor Air Measurement Operation

The outdoor air measurement operation uses air measurement stations with the outdoor and return air dampers to control the amount of outdoor air entering the unit to a setpoint. Two outdoor air measurement operation configurations are used. The control will read the configuration setting Airflow Measurement Capability to determine which outside airflow measurement equipment is installed on the unit. If the setting is set to 0, then there is no airflow measurement equipment installed and the control will use fixed minimum position approach to ventilation. Because of the characteristics of the airflow measurement transducers, an auto-zeroing process will be used to ensure that the airflow sensor or sensors are calibrated at zero airflow. The "Altitude" setting of the unit's location will be used to provide additional measurement accuracy. Calibration parameters will be used for the airflow station type with the airflow station area, with the altitude correction parameter to calculate airflow.

Because the installation of the rooftop unit with its air distribution system will affect the airflow characteristics, a means to adjust the airflow station measurements using air balancer supplied data is provided.

Minimum Flow Measurement Operation

The "Airflow Measurement Configuration" parameter is set to minimum. Minimum Flow Measurement is an approach where only the minimum required OA flow rate is measured. This is accomplished by using a small Air Measurement Station (AMS) capable of only measuring 25% of the full flow capability of the unit. This is a somewhat less expensive flow measurement option and provides reasonable accuracy at low flows. However, only airflows up to 25% are measurable by the system. This will be acceptable since maintaining only the minimum ventilation requirements is what is most important.

Full Flow Measurement Operation

The "Airflow Measurement Configuration" parameter is set to full. Full Flow Measurement is an approach where the full OA flow is measured by one large AMS. This approach is more expensive than the Minimum Flow Measurement approach; however, full OA flow is measurable. The only disadvantage to this approach is that flow measurement accuracy decreases as flow rate decreases and the inaccuracies can become quite substantial at relatively moderate flow rates.

AREA AND K-FACTOR

When an Air Measuring Station is installed from the factory, the following parameters should be set at the factory prior to the shipment of the unit. The following parameters are found under the CONFIGURATION key of the OptiLogic control: “AMS #1 Area”, “AMS #1 K-Factor”, “AMS #2 Area”, “AMS #2 K-Factor”. Table 18 lists the values that should be entered for each of the parameters based on the capacity of the unit.

OA Flow Sensor Auto-Zero

Each OA flow sensor will under go an auto-zero process to minimize the effect of zero drift on the sensor accuracy. Auto-zero will take place when:

- Occupancy state = unoccupied
- Supply Fan = OFF
- Outdoor Air Damper = closed

The controller will take three airflow measurements with a 5 minute interval between each measurement. The measurements will be used to calculate a correction to the airflow measurement used for control.

Airflow Correction Using Balancer Data

The outdoor airflow function will allow the entry of data to correct the airflow measurement based on measurements taken by an air balancer. Computation of the compensated OA flow adjusted by air balancer input is done through the following steps and computation:

- The air balancer takes measurements and calculates an airflow (CFM) for the AMS

- The measured airflow above is entered into the Primary Unit Controller through the parameter “AMS #X Balancer Calculated Airflow at Balance”. X can be either 1 or 2. Use 1 for the Minimum and Full flow measurement option. This parameter is found under the SERVICE key of the OptiLogic Panel.
- During the same time-period of the measurements by the air balancer, record the Primary Unit Controller calculated airflow for AMS 1 or 2. This information can be found under the parameter “Outside Air Damper Flow #X” under the OPERATION DATA key of the OptiLogic Panel.
- The Primary Unit Controller calculated airflow above is entered into the Primary Unit Controller through the parameter “AMS #Xcontroller Measured Air Flow at Balance”. This parameter is found under the SERVICE key of the OptiLogic panel.

Minimum Flow Measurement

If the Configuration setting “Airflow Measurement Configuration” is set to 1 (minimum), then the unit will be equipped with minimum flow-only measurement equipment. This arrangement consists of an AMS and damper sized for 25% total unit flow and a separate economizer damper sized for the remaining 75% (does not include an AMS). The following figure details this arrangement and indicates the three independently controlled dampers required for this option. Damper #1 and #2 will be arranged Normally Closed (0V = Closed, 10V = Open) and Damper #3 will be arranged Normally Open (0V = Open, 10V = Closed). See Figure 32.

TABLE 18 – AREA AND K FACTOR

| AIR MEASURING STATION OPTION | Open % Full | Unit Size (Tons) | 50, 55 | 60,65 | 70,75 | 80,85 | 90,95, 105 |
|------------------------------|-------------|----------------------|--------|-------|-------|-------|------------|
| MINIMUM | 25% | A1 (Flow area sq ft) | 3.61 | 3.61 | 4.17 | 4.17 | 4.72 |
| | | K1-1 | 0.751 | 0.751 | 0.770 | 0.770 | 0.775 |
| FULL | 100% | A1 (Flow area sq ft) | 14.44 | 14.44 | 16.67 | 16.67 | 18.89 |
| | | K1-1 | 0.705 | 0.705 | 0.666 | 0.666 | 0.673 |

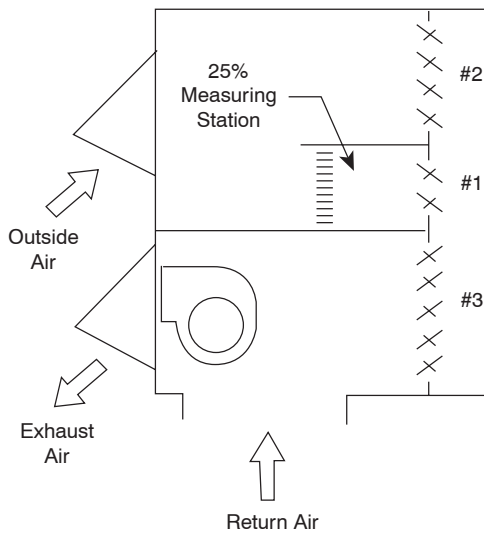

LD06563

FIG. 32 – MINIMUM FLOW MEASUREMENT ARRANGEMENT

A differential pressure transmitter will be used to measure a differential pressure across the AMS, which will correspond to an average velocity through the AMS. The measured differential pressure (read at an appropriate Analog Input) will be converted by the controller to an approximate flow. The entered data is for AMS #1.

When the unit is in the unoccupied mode of operation, dampers #1 and #2 will be 100% closed and damper #3 will be 100% open.

Airflow Control - Economizer Not Available

When the unit is in the occupied mode of operation, and:

- *Airflow Meas Config* = 1 (minimum)
- *Economizer Enable* = OFF, or
- *Economizer Enable* = ON and economizer conditions are not available:

Damper #2 will be closed and the following control of Dampers #1 and #3 will be used:

- On entering the airflow control mode of operation, Damper #3 (return air damper) is 100% open.
- An appropriate control algorithm will be used to modulate the position of Damper #1 (outdoor air) to maintain the *Minimum Flow Setpoint*.

- When the *Minimum Flow Setpoint* cannot be achieved with Damper #3 (Return Air Damper) 100% open, the RA Damper will be modulated closed so that the *Minimum Flow Setpoint* is achieved.
- The maximum closure of Damper #3 will be that position resulting in the maximum allowed airflow velocity through the AMS and Damper #1 or 1500 fpm. Divide the airflow by the area in table 18 to determine velocity.

The following figure is a representation of the damper versus airflow operation.

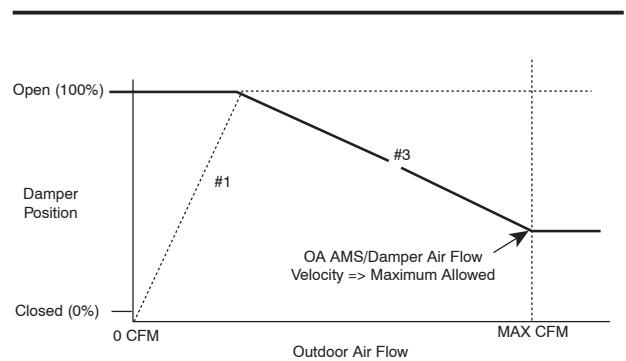

LD06564

FIG. 33 – CONTROL FOR MINIMUM AMS – ECONOMIZER NOT AVAILABLE

Air Flow Control - Economizer Available

When the unit is in the occupied mode of operation, and:

- *Airflow Meas Config* = 1 (minimum)
- *Economizer Enable* = ON and economizer conditions are available:

Damper #1, #2 and #3 will be controlled through an appropriate algorithm to meet the following two requirements:

- The measured outdoor airflow is => *Minimum Flow Setpoint*.
- The outdoor dampers are modulated to meet the requirements of economizer operation.

The Primary Unit Controller will use the difference between the Supply Air Temperature setpoint during economizer operation and the measured SAT and will increase the airflow above the "Min. Outside Airflow" to maintain the Supply Air temperature setpoint. The result is airflow through the damper will always be => the "Min. Outside Airflow".

- Mode 1 - Damper #1 and Damper #3 will be operated as described in *Airflow Control - Economizer Not Available* to satisfy the SAT temperature requirement using the increased airflow.

The Mode 1 to Mode 2 transition occurs when:

- The maximum AMS #1 velocity condition for Mode 1 airflow is present for 5 minutes or
- Damper #3 (Return Air) is closed for 5 minutes

Mode 2 operation is as follows:

- Damper #2 is modulated open to maintain the SAT Temperature Setpoint (as in economizer control without an AMS)
- Damper #1 and Damper #3 will be controlled to maintain the *Minimum Flow Setpoint*
- During this Damper #1 and #3 operation, the maximum closure of the Damper #3 (Return Air) will be determined by that required to limit the airflow rate through AMS #1 to ≤ 1500 fpm. Divide the airflow by the area in Table 18 to determine the velocity.

The Mode 2 to Mode 1 transition will occur when Damper #2 is continuously closed for 5 minutes.

The following figure illustrates the control functions.

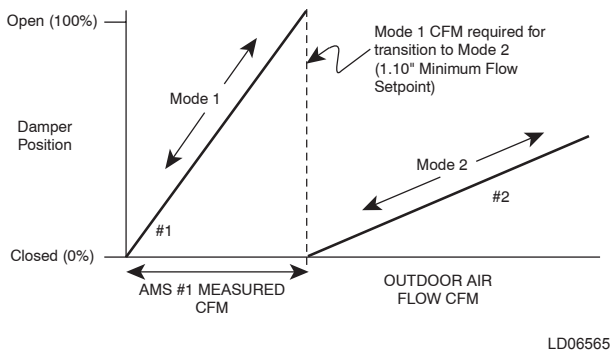

FIG. 34 – MINIMUM FLOW MEASUREMENT OPTION, ECONOMIZER SEQUENCE

Full Flow Measurement

If the Configuration setting "Airflow Measurement Config" is set to 2 (full), then the unit will be equipped with full flow measurement equipment. This arrangement consists of one AMS sized for 100% total unit flow. The following figure details this arrangement. With this arrangement, the outside and return air dampers are mechanically tied together. Only one Analog Output (AO) is required for this option.

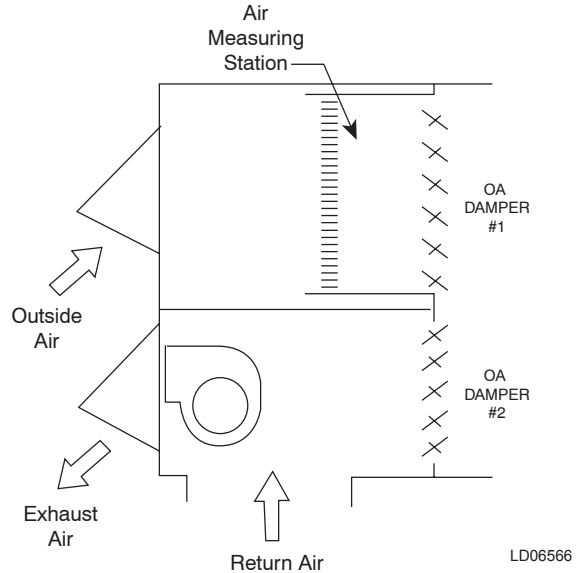

FIG. 35 – FULL FLOW MEASUREMENT ARRANGEMENT

A differential pressure transmitter is used to measure a differential pressure across the AMS, which will correspond to an average velocity through the AMS. The measured differential pressure (AI 11) will be converted by the controller to an approximate flow as given in the section on *Airflow Measurement Computation*. The entered data is for AMS #1.

In the unoccupied mode of operation the OA Damper is at 0% and the RA Damper is at 100%.

Flow Control - Economizer Not Available

When the unit is in the occupied mode of operation, and:

- *Airflow Meas Config* = 2 (full)
- *Economizer Enable* = OFF or

- *Economizer Enable* = ON and economizer conditions are not available

Damper #1 (outdoor air damper) will modulated as required to maintain the "Minimum Outside Airflow" by an appropriate PI control algorithm. The following figure illustrates the control function.

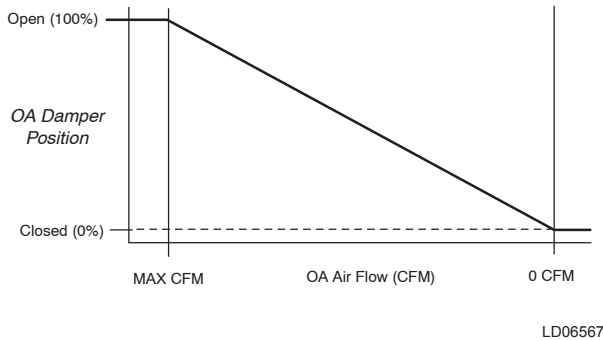

FIG. 36 – FULL FLOW MEASUREMENT OPTION, ECONOMIZER NOT AVAILABLE

Flow Control - Economizer Available

When the unit is in the occupied mode of operation, and:

- *Airflow Meas Config* = 2 (full)
- *Economizer Enable* = ON and economizer conditions are available

Damper #1 will be controlled through an appropriate algorithm to meet the following two requirements:

- The measured outdoor airflow is => *Minimum Flow Setpoint*
- The outdoor damper position is modulated to meet the requirements of economizer operation or economizer loading operation.

If the "OA Damper Min Pos 1 or 2" causes the airflow to be above the "Min Outside Airflow" setpoint, the damper will not close to allow the airflow to meet the "Min Outside Airflow" setpoint.

The following figure illustrates the control requirements.

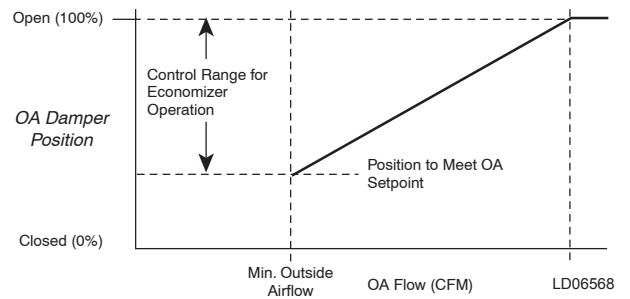

FIG. 37 – FULL FLOW MEASUREMENT OPTION ECONOMIZER SEQUENCE

Demand Ventilation

Demand Ventilation is a control sequence that can increase or decrease the amount of ventilation introduced to the building based on the level of contaminate in the conditioned space. Typically this is CO2 however based on the type of IAQ sensor used any contaminate could be used to increase the ventilation level. We will use CO2 in this example.

The demand for ventilation will be determined by comparing the level of CO2 in the building to the "Demand Ventilation" setpoint. The CO2 level in the building will be measured by an appropriate IAQ sensor connected to the unit.

The Demand Ventilation control sequence will only be allowed to function if:

- The "IAQ Sensor Enable" setting is set to ON.
- The unit is equipped with an economizer and *Economizer Enable* = ON.
- The *Airflow Meas Config* configuration is = 0 or 2
- Occupancy status is = Occupied.
- "Economizer Installed" is set to YES.

Demand Ventilation control will operate in both heating and cooling modes and will increase the position of the economizer (OA Damper) from the minimum position or the control positions of economizer or economizer loading as required to meet the "Demand Ventilation" programmed parameter.

Sensor

If all conditions are met, the control will look for an attached IAQ sensor at the appropriate AI 4. The reading at the AI 4 will be used along with the "*IAQ Sensor Span*" setting to determine the building CO₂ level. The sensor must be supplied in the field and the "*IAQ Sensor Span*" will vary based on the manufacturer and type of sensor.

If the CO₂ level indicated at the AI is out of range, the controller will interpret the reading as a sensor failure and generate a Trouble Fault. Demand Ventilation control sequences will not be allowed if the CO₂ sensor is determined to be unreliable.

Algorithm

An appropriate algorithm is used for Demand Ventilation control. A step and wait algorithm with the following characteristics is used:

- Step size is a function of the difference between the measured IAQ (CO₂) level and the *Demand Ventilation Setpoint*.
- Step time is fixed.

The Demand Ventilation operation will have the following constraints:

The maximum OA Damper position called for by Demand Ventilation operation will be equal to the ("*Max DV Multiplier*") * ("*OA Damper Min Pos #1*"). The "*Max DV Multiplier*" parameter can be set for a minimum of 1, which results in a damper position the same as the minimum position, to 4, which results in a damper position 4 times the minimum position.

LOW AMBIENT OPERATION

With the standard unit, mechanical refrigeration will only be allowed to operate when the ambient temperature is above the "*Cool Lockout OAT*" setting. Below this temperature, compressors will be inhibited from operating.

Optional hardware can be installed on one or more compressor systems that will allow mechanical refrigeration to occur below the *Cool Lockout OAT Setpoint*. The hardware for each Low Ambient configured system consists of a Condensing Pressure transducer on the refrigerant circuit and a Variable Speed Drive that varies the speed of one condenser fan to control the Condensing Pressure inside the condenser coil. The second condenser fan for the system is operated on/off through direct control by the compressor system. The following figure illustrates the equipment required for low ambient operation.

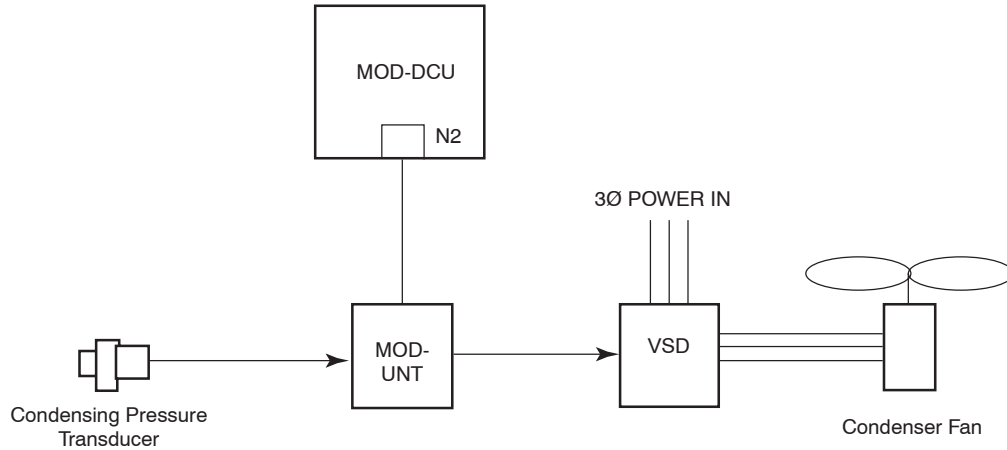

LD06574

FIG. 38 – LOW AMBIENT HARDWARE

To summarize the control, the MOD UNT monitors the condensing pressure at an appropriate input. The Primary Unit Controller will read the condensing pressure, perform the control logic, and command the

MOD-UNT to increase or decrease the output to the VFD, as required. The following figure illustrates the control logic required for this control loop.

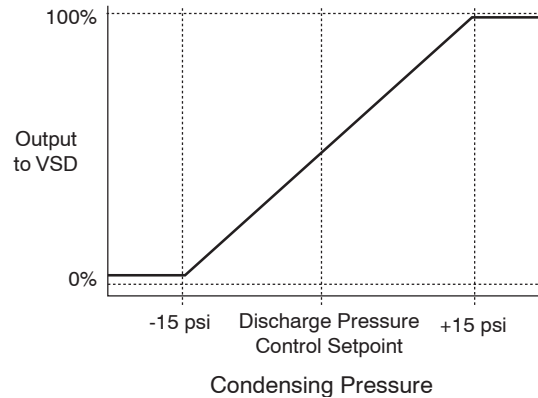

LD06575

FIG. 39 – CONDENSING PRESSURE CONTROL PROPORTIONAL BAND

Sequence of Operation

The control will read the configuration setting "*Low Ambient Config.*" to determine if low ambient hardware is installed and on what systems. Low ambient hardware can be installed on one, two, or three systems and is indicated as follows by the "*Low Ambient Config.*" Setting:

0. No low ambient hardware installed.
1. Low ambient hardware is installed on system #1 only.
2. Low ambient hardware is installed in system #1 and system #2.
3. Low ambient hardware is installed in system #1, #2, and #3.

Only systems with low ambient hardware will be allowed to operate below the *Low Ambient Lockout Temperature*.

Operation:

- If the Outside Air Temperature is above the *Low Ambient Lockout Temperature*, the controller will command all outputs for the VFD to 100%.
- If the OA Temperature falls below the *Low Ambient Lockout Temperature*, the controller will check for compressors operating. The control will then stop any compressors operating from systems not equipped with low ambient hardware. The control will monitor and control the condensing pressure on all systems equipped with the low ambient hardware. If the OA temperature falls to 0°F, all mechanical refrigeration will be stopped by the controller and not allowed to restart until the OA temperature rises above +10°F.
- A +/- 1°F hysteresis will be used about the Low Ambient Lockout Temperature.

Safeties

Communication Failure:

If the Primary Unit Controller detects a failure of the N2 communication with the MOD UNT, a fault will be generated and mechanical refrigeration below the Low Ambient Lockout Temperature will not be allowed.

The MOD UNT will continue to operate the condenser fans based on the measured discharge transducer input as last commanded by the DCU.

Unreliable Transducer:

If the discharge pressure becomes unreliable on any system, the controller will drive the VFD output for that system to 100% and prevent that system from operating below the *Cooling Lockout on OAT*. A fault will be generated.

CONTROLLING EXCESSIVE SUPPLY AIR TEMPERATURE SAT

This feature is not used. "*Excessive SAT- SAT Temper Available*" should always be configured to OFF.

POWER EXHAUST OPERATION

Power exhaust operation is used to control building pressure. For building pressure control, the unit can be equipped with the following exhaust air control configurations. These parameters are selected under "*Power Exhaust Config*".

- No power exhaust – "*None*"
- On/Off exhaust fan control based on the outside air damper position – "*2 Pos on OAD*"
- On/OFF exhaust fan control based on the building pressure– "*2 Pos on EAD*"
- On/Off exhaust fan control based on building pressure and modulating exhaust damper position – "*Modulating*"
- Proportional (VFD) exhaust damper control based on building pressure – "*Modulating*"

For power Exhaust Operation, the parameter "*Power Exhaust Enable*" must be programmed to ON and the supply fan must be running.

On/Off Control Based on OAD Position

On/Off control based on OAD position controls the powered exhaust fan ON or OFF based on the position of the Outside Air Damper. This option requires:

- "*Economizer Enable*" ON
- Supply Fan – ON
- Constant volume exhaust fan

This operation is not available when an OA Flow Station is installed.

The Exhaust Fan will be controlled by the OAD position as follows:

- Fan ON when the position = OAD Position for the Exhaust Fan to Turn ON. The damper position to turn on is programmed through the parameter “*OA DMPR Pos For ON*”
- Fan OFF when the position = OAD Position for the Exhaust Fan to Turn OFF. The damper position to turn off is programmed through the parameter “*OA DMPR Pos For OFF*”
- Exhaust fan OFF when Supply Fan is OFF

On/Off control Based on OAD Position is illustrated in Figure 40.

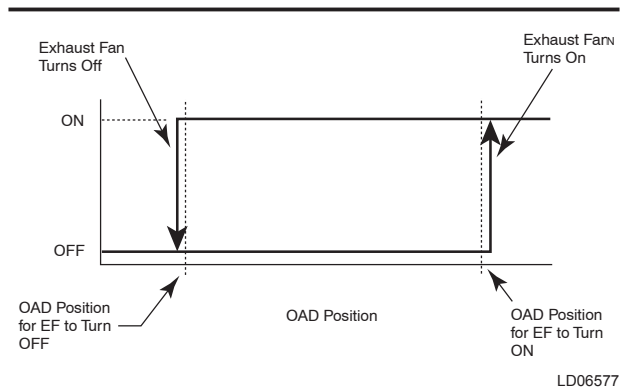

FIG. 40 – OAD POSITION CONTROL

On/Off Exhaust Fan Control Based on Building Pressure

This power exhaust option uses the building pressure to turn a constant volume exhaust fan on or off.

This option requires the following:

- “*Economizer Enable*” ON
- Supply Fan – ON
- Constant volume exhaust fan
- Building Pressure Transducer

When the Building Pressure reaches or exceeds the “*Building Pressure*” setting plus the “*Exhaust Cntrl Offset*”, the Primary Unit Controller will energize the constant volume Exhaust Fan. The Exhaust Fan will remain energized until the Building Pressure drops to or below the “*Building Pressure*” setting minus the “*Exhaust Cntrl Offset*”. Figure 41xxx illustrates this operation.

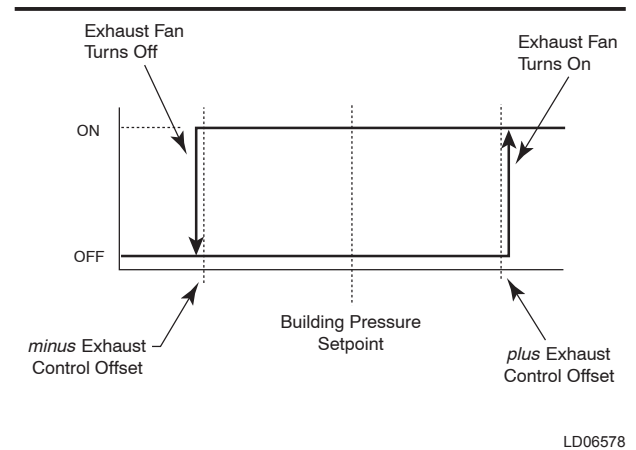

FIG. 41 – BUILDING PRESSURE CONTROL

On/Off Exhaust Fan Control Based on Building Pressure and Exhaust Damper Position

This power exhaust option uses the building pressure to modulate an exhaust damper. The position of the exhaust damper is used to turn a constant volume exhaust fan on and off.

This option requires the following:

- “*Economizer Enable*” ON
- Supply Fan – ON
- Constant volume exhaust fan
- Building Pressure Transducer
- Modulating Exhaust air damper

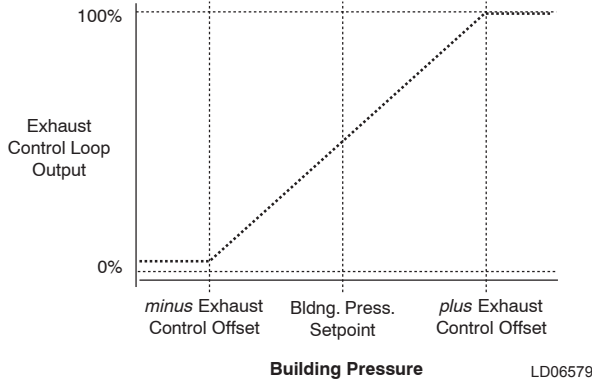

FIG. 42 – EXHAUST PROPORTIONAL BAND

The Primary Unit Controller will vary the position of the modulating exhaust damper based on the “Building Pressure” setting and the “Exhasut Cntrl Offset”. The damper will modulate from 0 to 100% with a building pressure range of the building pressure +/- the exhaust control offset. Figure 42 illustrates this operation. The constant volume exhaust fan will turn on and off based on the position of the exhaust damper as follows:

- Fan ON when the position = EAD Position for the Exhaust Fan to Turn ON. The damper position to turn on is programmed through the parameter “EXH DMPR Pos For ON”
- Fan OFF when the position = EAD Position for the Exhaust Fan to Turn OFF. The damper position to turn off is programmed through the parameter “EXH DMPR Pos For OFF”
- Exhaust fan OFF when Supply Fan is OFF

Figure 43 illustrates the On/Off operation of the exhaust fan.

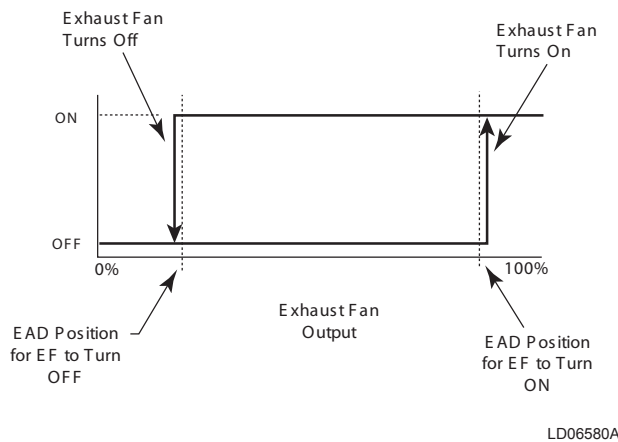

FIG. 43 – EXHAUST FAN CONTROL PROPORTIONAL OPTION

Proportional Exhaust Fan Control Based on Building Pressure

This power exhaust option uses the building pressure to vary the speed and airflow of a VFD exhaust fan. The VFD exhaust fan will still be turn On/Off based on the programmed position of the exhaust damper, even though a damper is not installed, but once the VFD exhaust fan is on it will vary its speed and airflow based on the “Building Pressure”.

This option requires the following:

- “Economizer Enable” ON
- Supply Fan – ON
- VFD exhaust fan
- Building Pressure Transducer

The VFD exhaust fan will turn on and off based on the position of the exhaust damper as follows:

- Fan ON when the position = EAD Position for the Exhaust Fan to Turn ON. The damper position to turn on is programmed through the parameter “EXH DMPR Pos For ON”
- Fan OFF when the position = EAD Position for the Exhaust Fan to Turn OFF. The damper position to turn off is programmed through the parameter “EXH DMPR Pos For OFF”
- Exhaust fan OFF when Supply Fan is OFF

After the VFD exhaust fan is turned on, the Primary Unit Controller will vary the speed of the VFD Exhaust fan based on the “Building Pressure” setting and the “Exhaust Cntrl Offset”.

Configurations employing Building Pressure requires the installation of a pressure sensor in the condition space and the connection of the sensor to the exhaust fan transducer. The location of this sensor is critical for proper operation of the exhaust fan. The sensor must be located so that the building pressure in the area it is monitoring is typical of the whole space.

TIME CLOCK / SCHEDULING

The controller will have a time of day clock and calendar with the following characteristics:

- Battery backup
- Time and date set through the RDU
- Clock and calendar compensated for Leap Year and Daylight Savings Time
- Event specification as follows:
 - Up to 16 holidays
 - A holiday schedule
 - A daily start and stop time (two times)
- Capability to set up multiple scheduling functions (i.e. time of day start-stop; time of day purge)
- Nominally +/- 4 seconds/day clock accuracy

CHANGEOVER RELAY OPERATION

The Changeover Relay (COR) is an external relay driven by the controller that allows the controller to operate 6 stages of cooling and 6 stages of heating from 6 controller outputs. The COR routes the stage signals from the controller to the compressors when mechanical cooling is required or to the staged heaters when heating is required.

The control of the Changeover Relay will be:

- For cooling operation: energize the COR output.
- For heating operation: deenergize the COR output.

Verification of the COR operation is done through the COR Status binary input (BI #15).

HIGH PRESSURE UNLOADING

The control will read the Transducer Package setting to determine if pressure transducers are installed on the unit. If the unit is equipped with pressure transducers, (*Transducer Package* setting set > 0) the control will monitor the discharge pressure from each refrigeration circuit with a pressure transducer package. If the discharge pressure of a refrigeration circuit rises to or above the *"Sys Unloading Press"* and both compressors of that circuit are ON, the control will turn OFF one of the compressors. This compressor will not be allowed to turn back on until the OAT drops 5°F.

If a refrigeration system is unloaded, a fault will be generated.

COMFORT VENTILATION OPERATION

Comfort Ventilation is applicable in CV (Constant Volume) unit configurations where:

- Space temperature is sensed through a Thermostat or Space Sensor.
- Economizer is installed.

Comfort Ventilation will operate when:

- *"Comfort Vent Mode"* is ON.
- Occupied is ON (occupancy detected).
- There is no call for heating or cooling due to the Thermostat or Space Sensor.
- If Demand Ventilation and/or Outdoor Airflow Control are enabled, these control modes are the first priority in establishing the OA Damper position.

Comfort Ventilation will operate as follows when enabled:

- Supply Fan will remain ON when mechanical refrigeration or heating are OFF.
- The Outdoor Air Damper will be modulated between the *"Comfort Vent Max Damper"* Position and the *"OA Damper Min Position #1"*.

Economizer Control During Comfort Ventilation

Economizer control will use a PI controller that controls SAT within the specified SAT band by repositioning the economizer dampers. The PI controller setpoint will be calculated as a midpoint between the programmed *"Comfort Vent High SAT"* setpoint and *"Comfort Vent Low SAT"* setpoint. As the controller uses outside air to maintain the SAT at the setpoint, it must be capable of self-configuration for direct, or reverse action, depending on the relationship of the OAT to the specified SAT control band:

- If the OAT is below the specified *"Comfort Vent Low SAT"* setting, the action will be direct acting. In this case, the economizer control can lower the SAT temperature just by opening the economizer damper and using more outdoor air. However, if the economizer controller can not prevent the SAT from dropping below the bottom control band limit by closing the economizer damper to its programmed minimum position, one or more heating stages are turned ON as required. Similarly, if the economizer controller can not prevent the SAT from increasing above the top control band limit by opening the economizer damper to its programmed *"Comfort Vent High SAT"* setpoint, one or more compressors will be turned ON as required.

- If the OAT is above the specified "*Comfort Vent High SAT*" setpoint, the action will be Reverse Acting. In this case, the economizer control can increase the SAT temperature just by opening the economizer damper and using more outdoor air. However, if the economizer controller can not prevent the SAT from increasing above the top control band limit by closing the economizer damper to its programmed minimum position, one or more compressors will be turned ON as required. Similarly, if the economizer controller can not prevent the SAT from dropping below the bottom control band limit by opening the economizer damper to its programmed "*Comfort Vent Low SAT setpoint*" setpoint, one or more heating stages will be turned ON as required.
- If the OAT is within the SAT control band, (i.e. between the programmed "*Comfort Vent High SAT*" setpoint and "*Comfort Vent Low SAT setpoint*" setpoint), the economizer damper will be overridden to fully open position subject to OA flow requirements if installed and enabled. In this case, no other control action needs to be taken to maintain the SAT within the specified control band

Staging Control During Comfort Ventilation

The economizer control alone may not be able to maintain the SAT within the specified control band. A separate staging control algorithm supplements the economizer control and stages heating or mechanical cooling as necessary.

The cooling and heating operation will be as follows:

- If the SAT increases above the "*Comfort Vent High SAT*" setpoint for more than 5 minutes:
 - If heating is ON, destage a heating stage - At 5 minute intervals, repeat this test until all heating stages are OFF.
 - If heating is OFF, stage a compressor ON - At 5 minute intervals, repeat this test until SAT is below the "*Comfort Vent High SAT*" setpoint .
- If the SAT decreases below the "*Comfort Vent Low SAT*" setpoint for more than 5 minutes:
 - If cooling is ON, destage a compressor - At 5 minute intervals, repeat this test until all cooling stages are OFF.
 - If cooling is OFF, stage a heating stage ON - At 5 minute intervals, repeat this test until SAT is above the "*Comfort Vent Low SAT*" setpoint.

As the heating stages, or compressors are staged up, or destaged, the economizer controls continue using the economizer damper to "trim" the effect of the staging and to maintain the SAT as near the middle of the SAT control band as possible.

If the unit is using hydronic heat, the control will modulate the water valve to maintain SAT at the programmed "*Comfort Vent Low SAT*" setpoint. At this setpoint, the hydronic heat control does not conflict with the economizer control, and will prevent SAT from dropping outside of the specified control band when the economizer can no longer maintain the SAT at its middle-of-the-band setpoint.

HOT WATER FREEZE PROTECTION USING RETURN AIR OPERATION

When programmed for Hot Water or Steam, Return Air monitoring will be used for freeze protection. If the RA temperature is less than 40°F and the Supply Fan is OFF, the Heating Valve output will open to 100%.

When the Supply Fan is ON, or the RA temperature is greater than 50°F, the Heating Valve output returns to normal operation. No fault is generated by this operation.

SMOKE PURGE OPERATION

The Smoke Purge Operation will have five selectable options.

Setting #1, Shutdown

If the smoke purge setting is set to 1 and the Smoke Purge input is activated, the unit will do the following:

- Disable the Exhaust Fan, if activated.
- Disable the Supply Fan, if activated.
- Close the Outside Air damper(s).
- Open the Return Air damper.

Maintain this operation until the Smoke Purge input is deactivated, then return to normal operation.

Setting #2, Pressurization

If the smoke purge setting is set to 2 and the Smoke Purge input is activated, the unit will do the following:

- Disable the Exhaust Fan, if activated.
- Turn ON the Supply Fan full (VFD to 100%).
- Energize the VAV Heat Relay and drive all VAV boxes open.
- Open the Outside Air dampers full.
- Close the Return Air damper full.

Maintain this operation until the Smoke Purge input is deactivated, then return to normal operation.

Setting #3, Exhaust

If the smoke purge setting is set to 3 and the Smoke Purge input is activated, the unit will do the following:

- Disable the Supply Fan.
- Close the Outside Air damper(s).
- Turn ON the Exhaust Fan full (VFD/ED to 100%)

Maintain this operation until the Smoke Purge input is deactivated, then return to normal operation.

Setting #4, Purge

If the smoke purge setting is set to 4 and the Smoke Purge input is activated, the unit will do the following:

- Turn ON the Supply Fan full (VFD to 100%).
- Energize the VAV Heat Relay and drive all VAV boxes open.
- Turn ON the Exhaust Fan full (VFD/ED to 100%).
- Open the Outside Air Damper(s) full.
- Close the Return Air Damper full.

Maintain this operation until the Smoke Purge input is deactivated, then return to normal operation.

Setting #5, Purge w/ Duct Pressure Control

If the smoke purge setting is set to 5 and the Smoke Purge input is activated, the unit will do the following:

- Supply Fan
 - VAV units - Turn ON the Supply Fan VFD and control to the Duct Static Setpoint.
 - CV - Turn ON fan (variable output is 100%)
- Turn ON the Exhaust Fan full (VFD/ED to 100%)
- Open the Outside Air Damper(s) full.

- Close the Return Air Damper full.

Maintain this operation until the Smoke Purge input is deactivated, then return to normal operation.

RETURN FAN OPERATION

The following is an explanation of the different modes of operation for the return fan option

No Outdoor Air, 100% Return Air, VFD Supply Air Fan, No Exhaust

This configuration would be for applications where the supply fan performance cannot meet the total static requirement of the duct system. This allows the external static pressure to be split between the return air and supply air fan.

- Application uses two return air fans each with their own motor being controlled by a single VFD drive.
- The return fan VFD drive is controlled by a pressure transducer with a static pressure probe located in the return section of the unit.
- The return fan VFD is programmed to maintain -.03 to -.05 inches of WC static at the probe. These values are programmed into the VFD at the factory. The value can be verified by checking item # 204 and 205 in Menu 2 (References and Limits) in the VFD program. Refer to Installation, Operation & Maintenance Form 100.40-N04 for additional information.
- The supply air VFD is controlled by the duct static transducer.
- The supply air blower and return air fan will always be energized together.
- As the pressure in the return air section becomes more negative the return air fan will speed up. As the pressure in the return section increases above the setting the return air fan will slow down

No Outside Air, 100% Return Air, VFD Supply Fan, with Motorized Exhaust Damper

This configuration would be used for applications where the supply fan performance cannot meet the total static requirement of the duct system and there is make up air units or other outside air sources supplying air to the space. This allows the external static pressure to be split between the return air and supply air fan while removing the excess air from the building.

- Applications uses two return air fans each with their own motor being controlled by a single VFD drive.
- The return fan VFD drive is controlled by a pressure transducer with a static pressure probe located in the return section of the unit.
- The return fan VFD is programmed to maintain +0.1 to +0.15 inches of WC of static at the probe. These values are programmed into the VFD at the factory. The value can be verified by checking item # 204 and 205 in Menu 2 (References and Limits) in the VFD program. Refer to Installation, Operation & Maintenance Form 100.40-N04 for additional information.
- The unit will also require a motorized exhaust air damper that operates off a building pressure transducer.
- The supply air VFD is controlled by the duct static transducer.
- The supply air blower and return air fan will always be energized together.
- The speed of the indoor blower and the opening of the exhaust air damper will both influence the speed at which the return air fan operates.

0 – 25% Manual /2 Position Outside Air, VFD Supply Fan, with No Exhaust

This configuration would be used for applications where the supply fan performance cannot meet the total static requirement of the duct system. Ventilation air is supplied through the unit but exhaust is handled by other means. This allows the external static pressure to be split between the return air and supply air fan while bringing ventilation air into the building.

- Applications uses two return air fans each with their own motor being controlled by a single VFD drive.
- The return fan VFD drive is controlled by a pressure transducer with a static pressure probe located in the mixed air return section of the unit.
- The return fan VFD is programmed to maintain -.03 to -.05 inches of WC static at the probe. These values are programmed into the VFD at the factory. The value can be verified by checking item # 204 and 205 in Menu 2 (References and Limits) in the VFD program. Refer to Installation, Operation & Maintenance Form 100.40-N04 for additional information.

- The supply air VFD is controlled by the duct static transducer.
- The supply air blower and return air fan will always be energized together.
- As the pressure in the return air section becomes more negative the return air fan will speed up. As the pressure in the return section increases above the setting the return air fan will slow down.
- The percent of outdoor air will remain the same regardless of the airflow through the unit.

0 – 25% Manual /2 Position Outside Air, VFD Supply Fan, with Motorized Exhaust Damper

This configuration would be used for applications where the supply fan performance cannot meet the total static requirement of the duct system. Ventilation air is supplied through and exhausted by the unit. This allows the external static pressure to be split between the return air and supply air fan while bringing ventilation air into the building and exhausting return air.

- Applications uses two return air fans each with their own motor being controlled by a single VFD drive.
- The return fan VFD drive is controlled using a pressure transducer with a static pressure probe located in the mixed air return section of the unit.
- The return fan VFD is programmed to maintain -.03 to -.05 inches of WC static at the probe. These values are programmed into the VFD at the factory. The value can be verified by checking item # 204 and 205 in Menu 2 (References and Limits) in the VFD program. Refer to Installation, Operation & Maintenance Form 100.40-N04 for additional information.
- The unit will also require a motorized exhaust air damper that operates off a building pressure transducer.
- The supply air VFD is controlled by the duct static transducer.
- The supply air blower and return air fan will always be energized together.
- As the pressure in the return air section becomes more negative the return air fan will speed up. As the pressure in the return section increases above the setting the return air fan will slow down.
- The percent of outdoor air will remain the same regardless of the airflow through the unit.

- The speed of the indoor blower and the opening of the exhaust air damper will both influence the speed at which the return air fan operates.

Fully Modulating Economizer Option with VFD Supply Air Fan but No Exhaust Option

This configuration would be used for applications where the supply fan performance cannot meet the total static requirement of the duct system employing a modulating outdoor and return air damper system without exhaust. This allows the external static pressure to be split between the return air and supply air fan while having the capability of 100% outdoor air for cooling. Building pressurization would have to be handled by an external means.

- Applications uses two return air fans each with there own motor being controlled by a single VFD drive.
- The return fan VFD drive is controlled using a pressure transducer with a static pressure probe located in the mixed air section of the unit.
- The return fan VFD is programmed to maintain -.03 to -.05 inches of WC static at the probe. These values are programmed into the VFD at the factory. The value can be verified by checking item # 204 and 205 in Menu 2 (References and Limits) in the VFD program. Refer to Installation, Operation & Maintenance Form 100.40-N04 for additional information.
- The return fan static pressure setpoint is reset based on the supply air fan VFD output.
 - When the supply air fan output is at minimum, the setpoint will be -0.1 to 0.2 inches of WC.
 - When the supply air fan output is at maximum, the setpoint will be -0.5 to -0.6 inches WC.
- The change in return fan static pressure setpoint allows the unit to maintain a linear and consistent outside and return airflow at all supply airflow rates.
- The supply air VFD is controlled by the duct static transducer.

- The supply air blower and return air fan will always be energized together.
- As the pressure in the return air section becomes more negative the return air fan will speed up. As the pressure in the return section increases above the setting the return air fan will slow down.
- The return air damper will never go to a totally closed position.

Fully Modulating Economizer Option with VFD Supply Air Fan and Motorized Exhaust Damper

This configuration would be used for applications where the supply fan performance cannot meet the total static requirement of the duct system employing a modulating outdoor and return air damper system with motorized exhaust. This allows the external static pressure to be split between the return air and supply air fan while having the capability of 100% outdoor air for cooling.

- Applications uses two return air fans each with there own motor being controlled by a single VFD drive.
- The return fan VFD drive is controlled using a pressure transducer with a static pressure probe located in the mixed air section of the unit.
- The return fan VFD is programmed to maintain -.03 to -.05 inches of WC static at the probe. These values are programmed into the VFD at the factory. The value can be verified by checking item # 204 and 205 in Menu 2 (References and Limits) in the VFD program. Refer to Installation, Operation & Maintenance Form 100.40-N04 for additional information.
- The return fan static pressure setpoint is reset based on the supply air fan VFD output.
 - When the supply air fan output is at minimum, the setpoint will be -0.1 to 0.2 inches of WC.
 - When the supply air fan output is at maximum, the setpoint will be -0.5 to -0.6 inches WC.
- The change in return fan static pressure setpoint allows the unit to maintain a linear and consistent outside and return airflow at all supply airflow rates.

- The unit will also require a motorized exhaust air damper that operates off a building pressure transducer.
- The supply air VFD is controlled by the duct static transducer.
- The supply air blower and return air fan will always be energized together.
- As the pressure in the return air section becomes more negative the return air fan will speed up. As the pressure in the return section increases above the setting the return air fan will slow down.

last section on and the first section off. The number of stages between 1A and 1B operation is depended on the number of heating sections installed in the unit. The modulating heat section, 1A, must always modulate to full fire before any additional stages can be brought on. When additional stages are required, the modulating heat section will go to minimum fire and the next stage of heating will be brought on. If there continues to be a demand for additional heat, the modulating heat section re-modulates to high fire before any additional stages can come on. During a decrease in heating demand, the modulating heat section must be at a minimum fire condition before any stages are turned off.

MODULATING GAS HEAT

Modulating gas heat can be ordered with a minimum of two gas heat stages (1 heat exchanger section) and a maximum of six stages (three heat exchanger sections).

Fig 44 shows the staging sequence for the modulating heat stages. As can be seen from the chart, Heat section 1A (modulating) is always the first section on and the last section off. Heat section 1B is always the

The following Primary Unit controller parameters are required for modulating heat operation. These values will be entered into the control at the factory. Under the CONFIGURATION key of the OptiLogic control panel the “# of Heat Steps” will be set to 0. This value does not change regardless of the number of stages installed. Under the CONFIGURATION key of the OptiLogic control panel the “Heating Type” will be set to HW, even though the unit is fired on gas. Under the SETPOINTS key of the OptiLogic control panel

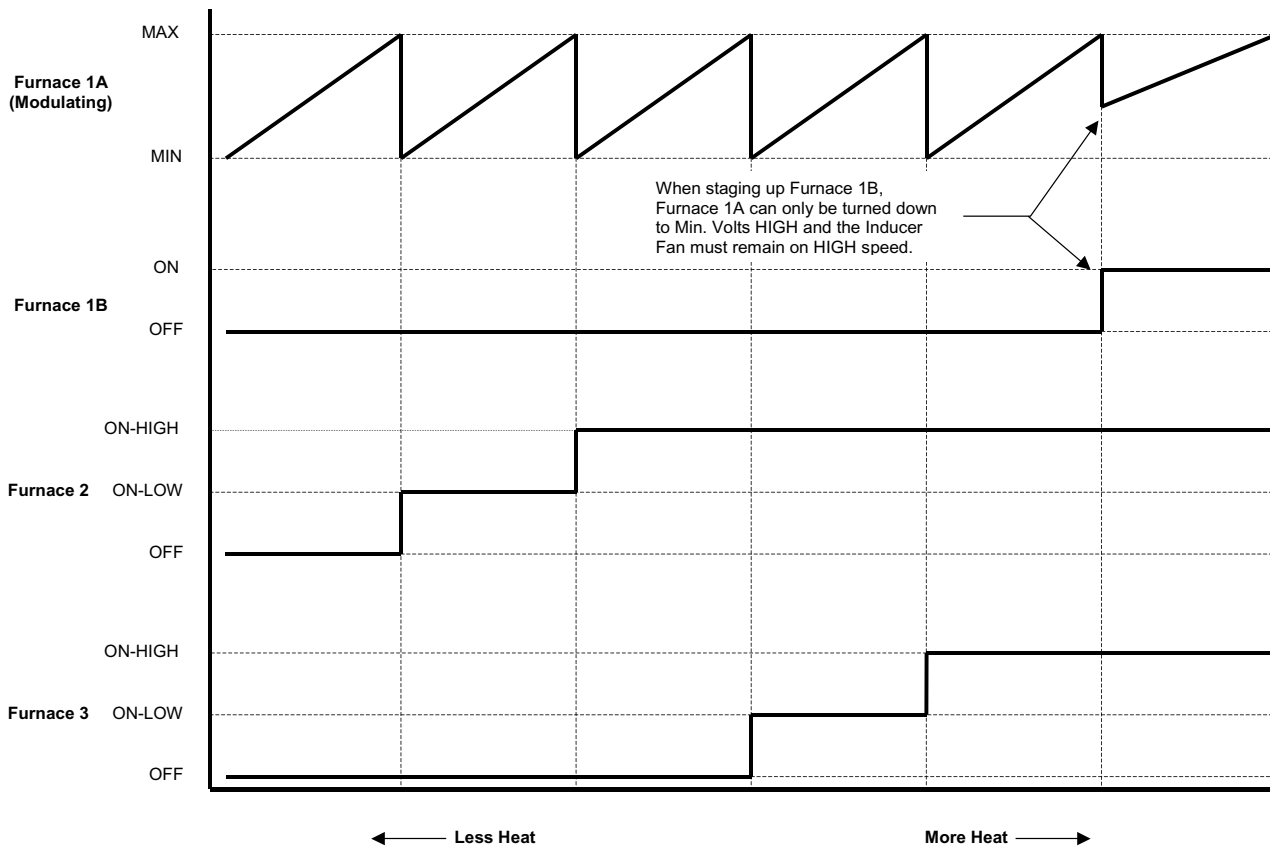

FIG. 44 – MODULATING GAS HEAT STAGING

the “*Hydro Heat 1st Stage*” is field adjustable but is factory set with a default value of 100° F. Under the SETPOINTS key of the OptiLogic control panel the “*Hydro Heat 2nd Stage*” is field adjustable but is factory set with a default value of 115° F.

The Furnace Controller, found in the gas heat section, will also be configured at the factory based on the number of gas heat sections installed. This configuration is performed at terminal 5 and 6 of terminal block TB2 of the Furnace Controller. If there is a single heat section installed there will be no connection between the two terminals. If there is two heat sections installed there will be a 1K ohm ½ watt resistor between the two terminals. If there is three heat sections installed there will be a jumper between the two terminals.

The Primary Unit Controller generates a 0 to 10 volt signal to the Furnace Controller based on the temperature difference between the supply air temperature (SAT) and the “*Hydro Heat 1st Stage*” or “*Hydro Heat 2nd Stage*”. Refer to Table 16 and 17 for an explanation on how the Primary Unit Controller determines when heating is required for the different modes of unit operation.

The 0 to 10 volt output represents a 30 degree temperature range (3 degrees = 1 volt). The midpoint of the 30 degree range is the SAT midpoint. This midpoint equals a 5 volt output to the Furnace Controller.

The Furnace Controller has a default +/- one degree offset from the midpoint. When the voltage input to the Furnace Controller is between 4 and 6 volts the controller maintains the current state of furnace operation, it will neither increase nor decrease the amount of heat.

When the voltage is between 6 and 10 volts, the Furnace Controller increases the heating output. When the voltage is between 0 and 4 volts, the Furnace Controller will decrease the heating output.

A voltage greater than 5 volts is required for the modulating furnace section to start. A voltage level less than 1 volt will turn the furnace off.

COMPRESSOR OPERATING CONTROLS

The following information describes the sequence of operation for the compressor unit control components. The information below describes System 1A and 1B

compressor operation. This same information can also be applied to System 2A and 2B and System 3A and 3B.

- When the Primary Unit Controller identifies a need for compressor operation it energizes the Cooling Change Over Relay (C/O) 12R and switches the binary outputs BO1 for compressor A1 operation and BO2 for compressor A2 operation from the Primary Unit Controller to the smart Relay SR1.
- The Smart Relay SR1 sends a 120 volt output from the Q1 output (compressor 1A) Q2 (compressor 1B) to the 1M (compressor 1A), 2M (compressor 1B) contactor which energizes compressor 1A and/or 1B.
- The Smart Relay SR1 also sends a 120 volt output from the Q3 output to the 7M contactor which energizes one condenser fan.
- The Smart Relay also receives an input signal from an ambient thermostat 9STAT at terminal I5. The thermostat opens at 75°F and closes at 85°F. If the switch is closed and there is a call for both compressor 1A and 1B the Smart Relay will send a 120 volt signal from terminal Q4 of the Smart Relay to the 8M contactor and the second condenser fan for system 1 is energized.
- Flexsys units have a solenoid valve (4LLSV) installed prior to one of the two system expansion valves in order to keep one half the system circuit inactive unless both compressors are on. Both compressor contactors 1M and 2M have auxiliary normally open contacts that close when the contactor is energized. The two auxiliary contacts are in series and control the operation of the solenoid valve. Both the auxiliary contacts must be closed before 120 volts is supplied to energize and open the solenoid valve.
- If pumpdown is installed on the unit the solenoid valve in the main system liquid line (1LLSV) will be energized with the 7M contactor at the beginning of the cycle.
- The Smart Relay uses an input to terminal I4 to monitor the condition (open or closed) of the low pressure switch. When a call for mechanical cooling for System 1 is removed, the Smart Relay deenergizes the Q3 and Q4 outputs which opens contactors 7 and 8 M and deenergizes the liquid line solenoid valve (1LLSV).

- The Smart Relay continues to keep the Q1 or Q2 contact closed until the pressure switch input to terminal I4 of the Smart Relay is removed, or for 30 seconds; whichever occurs first.
- The Smart Relay then opens the Q1 or Q2 contact shutting off the compressor.

REFRIGERANT SAFETY OPERATION

Freezestat Operation

- Freezestat protection only applies if both compressors of the system are energized.
- Both compressors must have been operating for 2 minutes before a lockout can occur.
- The Smart Relay monitors the freezestat input at terminal I3. If the input is lost, the Smart Relay turns off the Q2 output and compressor 1B is turned off.
- The Smart Relay will not close the Q2 contact until 10 minutes has elapsed since the freezestat trip, provided the freezestat contacts closed during the 10-minute time frame.

Compressor Safety Chain

- Each of the tandem compressor systems has a compressor safety chain consisting of the following components. Low Pressure Cutout, High Pressure Cutout, Compressor Motor Protector, Compressor Current Overload
- The above safeties are in series and are connected to the BI1, for system 1; BI 2, for system 2; BI3, for system 3, inputs to the Primary Unit Controller.
- The Primary Unit Controller monitors the compressor safety chain inputs only when a compressor from that system is operating.
- When a compressor is started the control shall ignore the compressor safety chain for 30 seconds.
- After the 30 seconds start delay, if the status is not present for more than one second, the control shall de-energize all compressors operating in that compressor safety chain.
- The Primary Unit Controller then waits ten minutes before making the compressors in the tripped system available for operation, provided the compressor safety chain has reset.
- Each compressor system shall be assigned two trip counters, both counters shall start at zero.

- Counter #1 shall:
 - Increment by 1 any time a trip occurs when either one or two compressors on the tripped compressor system are on.
 - Be reset to zero counts if the compressor system status input is present for one cumulative hour of compressor operation following the last compressor safety trip.
 - Be reset to zero if the power to the Primary Unit Controller is removed and reestablished.
- Counter #2 shall:
 - Increment by 1 any time a trip occurs and both compressors on the system are operating.
 - Be reset to zero counts if the compressor system status input is present for one cumulative hour of compressor operation following the last compressor safety trip.
 - Be reset to zero if the power to the Primary Unit Controller is removed and reestablished.
- If the count of either compressor status counter on a compressor system = 3
 - The compressors on the system are shut down and locked out.
 - A compressor safety lockout fault is declared.
- The power to the Primary Unit Controller must be removed and reestablished to clear a safety lockout fault.

FLEXSYS VAV OPERATION

Description of Operation

In the Flexsys mode of operation the unit operates in the VAV Stand-Alone mode and does not use a thermostat or space sensor input. See Table 17 for a summary of the VAV Stand-alone mode of operation. In a Flexsys system the eco² unit supplies condition cool air to a under floor delivery system. Compressor operation is controlled based on the supply air temperature leaving the evaporator coil. Additional sensors are added to monitor the temperature of the air off the evaporator coil. The unit has an opening below the supply air blower that allows return air to flow through a bypass duct and mix with the air off the coil. There is a damper in the by-pass duct, which modulates to temper the temperature of the mixed air being sent to the underfloor system. The unit will also accept an analog input from an underfloor temperature and humidity sensor. These sensors can be used to monitor the dew point of the air under the floor and can reset the SAT temperature if the air approaches the dew point.

The following parameters are used to set up an eco² unit for Flexsys operation.

- Under the Configuration key of the OptiLogic Control the “Unit Type” must be set to “Flexsys”.
- Under the Setpoints key of the OptiLogic Control the “VAV Cool High Temp” must be set. This is the setpoint for the temperature of the air off the evaporator coil, which the Primary Unit Controller will use to stage the economizer and mechanical cooling.
- Under the Setpoints key of the OptiLogic Control the “VAV Cool Low Temp” must be set. This is the setpoint of the temperature of the air off the evaporator coil that the Primary Unit Controller uses to stage the mechanical cooling if the under floor temperature and humidity approaches the dew point.
- Under the Setpoints key of the OptiLogic Control the “Flexsys MSAT Setpoint” must be set. This is the setpoint of the temperature of the air the eco² unit will try to deliver to the underfloor system.
- Under the Setpoints key of the OptiLogic Control the “Flexsys Min Dewpt Diff” must be set. When the dew point of the under floor space gets within this number of degrees of the actual dewpoint the Primary Unit Controller switches to the “VAV Cool Low Temp” setpoint.
- Under the Unit Setup key of the OptiLogic Control the “Flexsys Dewpt Reset” must be set to ON if an underfloor temperature and humidity sensor is being used to reset the supply air temperature.

A modulating damper is used to vary the amount of Return Air By-passed from the Return air Duct to the

fan section of the rooftop unit.

- The damper is direct acting (0 VDC – bypass damper 100% open, 10 VDC – bypass damper closed).
- During Unoccupied Modes of operation and during Morning Warmup, the bypass damper is commanded 100% open (10 VDC).
- During the Occupied Mode of operation, the bypass damper is controlled to maintain the “Flexsys MSAT” Setpoint.
- The minimum time for the by-pass damper to go from full open to closed or closed to full open will be approximately 15 minutes.
- The Primary Unit Controller will calculate a by-pass damper set point using formula 1 in Figure 45:
- The Primary Unit Controller will calculate the Active By-pass Percentage using formula 2 in Figure 45:
- The by-pass damper will be controlled as follows:
 - If the Actual By-pass Percentage is \geq to the (By-pass Percentage Setpoint + 2.5⁰ F) the By-pass damper will close until the Actual By-pass Percentage is equal to the By-pass Percentage Setpoint
 - If the Actual By-pass Percentage is \leq to the (By-pass Percentage Setpoint - 2.5⁰ F) the By-pass damper will open until the Actual By-pass Percentage is equal to the By-pass Percentage Setpoint.

Formula 1

$$\text{By-pass Percentage Setpoint} = \frac{\text{Flexsys MSAT Setpoint} - \text{Supply Air Temperature Setpoint}}{\text{Return Air Temperature} - \text{Supply Air Temperature Setpoint}}$$

Formula 2

$$\text{Actual By-pass Percentage} = \frac{\text{Current MSAT Temperature} - \text{Current Supply Air Temperature}}{\text{Current Return Air Temperature} - \text{Current Supply Air Temperature}}$$

FIG. 45 – BY-PASS DAMPER FORMULAS

- If the (By-pass Percentage Setpoint – 2.5° F) < Actual By-pass Setpoint < (By-pass Percentage Setpoint + 2.5° F) the bypass damper will not move.
- A change in the By-pass Damper position will only be allowed to occur 2 minutes after a compressor is started or stopped.
- Immediately after a compressor is started and stopped, the By-pass Damper will be fixed by the Primary Unit Controller
- The Primary Unit Controller will not open or close the By-pass Damper until the SAT temperature fall below the RAT.
- If the SAT temperature is above the RAT, the By-pass Damper shall remain fixed.

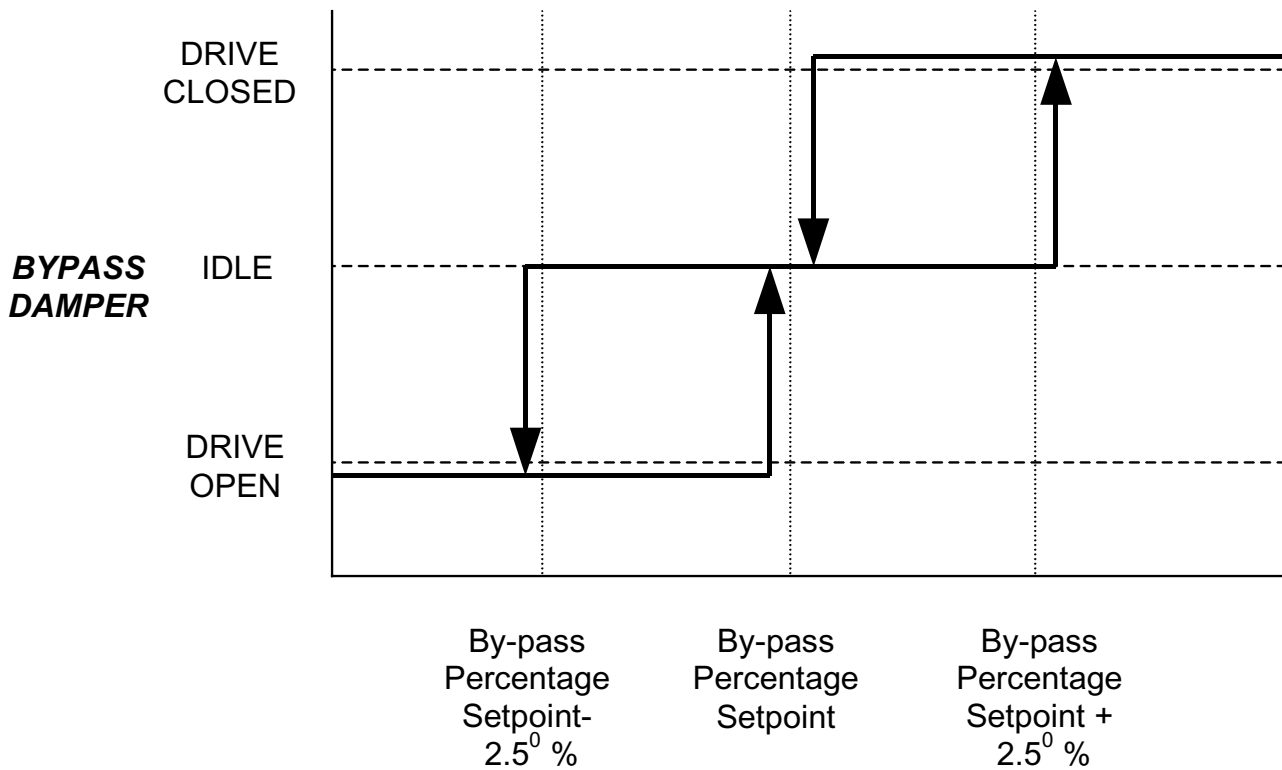

LD09792A

FIG. 46 – BYPASS DAMPER SETPOINTS