 <p>YORK[®] BY JOHNSON CONTROLS</p>	<p align="center">LONG-TERM STORAGE REQUIREMENTS - FIELD PREPARATION YR, YS, AND YVWA SCREW CHILLERS</p>	
<p>SERVICE POLICY & PROCEDURES</p>	<p>Supersedes: 50.20-NM9 (806)</p>	<p>Form 50.20-NM9 (1011)</p>

**Failure to comply with these requirements will render
any written or implied Johnson Controls warranty null and void.**

I. SUPPLEMENTARY DOCUMENTATION

The following documentation is required to FULLY COMPLY with the Long-Term Storage Requirements.

A. Long-Term Storage Requirements – GENERAL. Refer to *Long-Term Storage Requirements (Form 50.20-NM1)*.

B. Long-Term Storage Requirements – PERIODIC CHECKLIST AND LOGS (YR, YS, and YVWA). Refer to *Long-Term Periodic Checklist and Logs (Form 50.20-CL9)*.

II. FIELD PREPARATION FOR LONG-TERM STORAGE

A. General

1. Remove and dispose of shipping bag.
2. Perform a visual inspection of the chiller. Note any damage in the field comments section of the *Long-Term Periodic Checklist and Logs (Form 50.20-CL9)*.
3. Touch up any paint that has worn or chipped off, using paint supplied in ship loose items. Prepare the surface as required, using a wire brush.
4. Verify that all ship loose items are present. Note any missing items on the *Long-Term Periodic Checklist and Logs (Form 50.20-CL9)*.

B. Electrical Equipment and Components (Control Panels, Power Panels, Optional Panels, Motors, etc.)

1. Electrical equipment and components shall not be stored, or left in an outdoor environment.
2. Electrical equipment and components shall not be stored or left in a wet or damp environment. Components sealed in plastic shrink-wrap do not exempt this requirement. Moisture will collect inside the plastic, resulting in corrosion of the cabinet, the electronic components and/or copper bus bars.
3. YORK vapor emitter(s) shall be installed inside each electrical and electronic components cabinet(s) to protect against corrosion. Openings in cabinets shall be taped closed to minimize air infiltration during the storage period. The quantity of emitters is determined by measuring the gross volume of space the component occupies. YORK P/N 026-37705-000 will protect a volume up to five cubic feet. YORK P/N 026-37706-000 will protect a volume up to 11 cubic ft. Both emitters have a service life of 12 months. If other emitters are used, they must supply equivalent protection.
4. Vapor emitters must be installed in the following equipment and components:
 - a. Power panel.
 - b. Control panel.
 - c. Any optional electric enclosures.
5. Motor Preparation: Install VCI131 foam pads in motor D-flange (YS chillers). This will provide corrosion protection for the motor/compressor shafts and couplings. Seal D-flange from air infiltration.

C. Shell Side Preparation

1. Units charged with refrigerant: Recover refrigerant into clean/evacuated approved cylinders. Store cylinders in a suitable location.
2. Make sure that all valves are open so that no part of the system is isolated.
3. With the machine at atmospheric pressure, install valve and pressure gauge. See *Table 1 and Figure 1 on page 2*.
4. Evacuate chiller using a vacuum pump to remove any residual refrigerant.

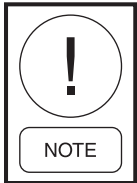

If refrigerant remains in the unit, the pressure will fluctuate with ambient conditions. This is undesirable as it may lead one to believe that a leak is present when one is not.

5. Pressurize the shell with approximately 5 psig (0.34 barg) of dry nitrogen.
6. Record pressure on the *Long-Term Storage Periodic Checklist and Logs (Form 50.20-CL9)*.
7. Make sure that plastic caps are installed on all relief valves to prevent dirt and moisture from entering valve.
8. Disconnect actuator linkage at center for pre-rotation vanes (PRVs), variable orifice and hot gas bypass valve (when supplied). Nuts and bolts should be attached to loose linkage so that they do not get lost.
9. Tape off sight glass with masking tape.

TABLE 1 - VALVE AND PRESSURE GAUGE

ITEM	DESCRIPTION	YORK P/N
1	Valve	022-09539-000
2	Gauge	026-18920-000
3	1/4 Swivel Union	023-04518-000
4	1/4 Ext. Flare to 1/4 NPTI	023-00903-000

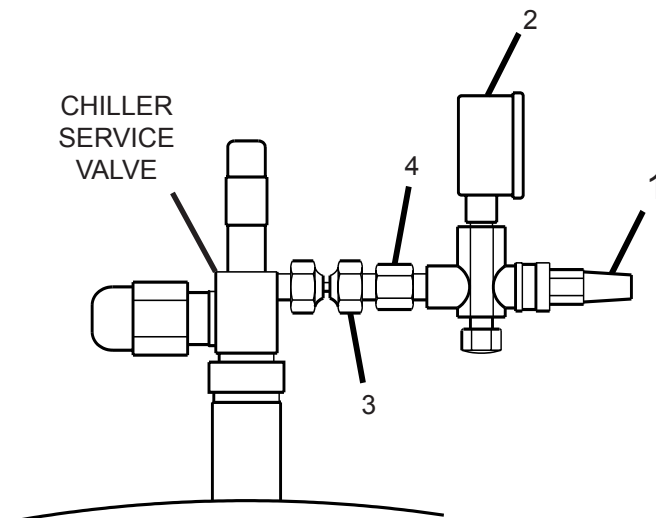
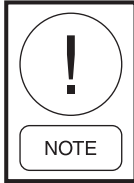

FIGURE 1 - VALVE AND PRESSURE GAUGE

D. Tube Bundle Preparation And Inspection

1. Remove existing nozzle shipping enclosures.
2. Inspect inside the water box to make sure that no moisture/corrosion or debris is present. Note damage on the *Long-Term Storage Periodic Checklist and Logs (Form 50.20-CL9)*.
3. Replace with suitable enclosures from *Tables 3 and 4 on page 4*.



Machines are typically shipped with either plastic or steel cover plates on machines shipped with 150 or 300 psig (10.2 or 20.4 barg) flanges.



The enclosures that are shipped standard from the factory are not designed to hold a positive pressure. They must be replaced.

4. Inspect all threaded fittings and clean with Loctite 7070. Replace all fittings.
5. Install fittings on water box vent connections. See *Table 2 and Figure 2 on page 4*.
6. Drain and dry bundles. Remove drain plugs/caps. Attach a nitrogen regulator to a nitrogen cylinder using a suitable hose. Purge dry nitrogen (approximately 0.5 psig (0.034 barg) through bundle for at least 20 minutes to make sure that no moisture is present in the bundles.

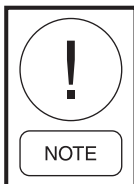

The presence of moisture can be verified by placing a mirror under the drain connection. If moisture is present, the mirror will have a tendency to fog.

7. Once bundles are dry, shut off nitrogen supply, reinstall drain fitting using Loctite cleaner/primer/sealant.
8. Pressure bundles to approximately 5 psig (0.34 barg) nitrogen holding charge. Record pressure on the *Long-Term Storage Periodic Checklist and Logs (Form 50.20-CL9)*.

TABLE 2 - WATER BOX CONNECTIONS

ITEM	DESCRIPTION	YORK P/N
1	Valve	022-09539-000
5	Gauge	026-18920-000
8	3/4 to 1/4 Reducer	023-01039-000

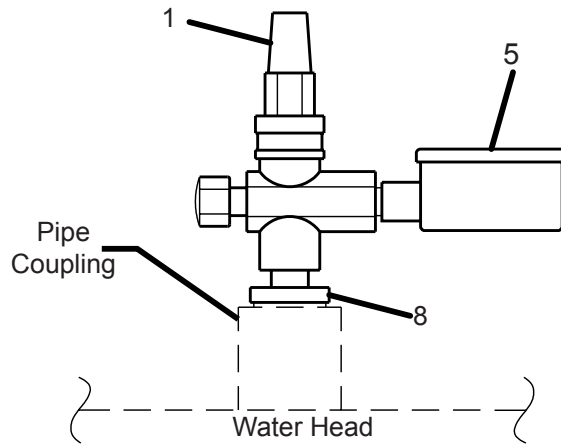

FIGURE 2 - WATER BOX CONNECTIONS

TABLE 3 - COOLER CLOSURES

SIZE (in/mm)	VICTAULIC COUPLING PART NUMBER	PIPE CAP PART NUMBER
4 (101)	023-15215-000	023-15222-000
6 (152)	023-15216-000	023-15223-000
8 (202)	023-15217-000	023-15224-000
10 (254)	023-15218-000	023-15218-000
12 (305)	023-15219-000	023-15219-000
14 (355)	023-15220-000	023-15227-000
16 (406)	023-15221-000	023-15228-000
18 (457)	023-17129-000	023-17130-000
20 (508)	023-18953-000	023-18945-000

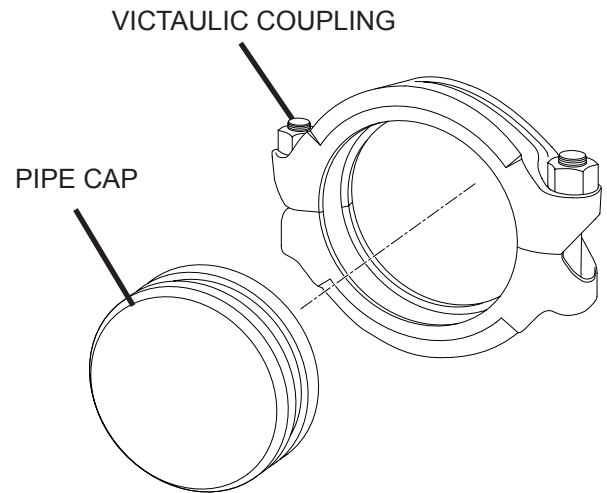

TABLE 4 - FLANGE CLOSURES

150 lbs. (56 kg) WATER FLANGE CLOSURES		
FLANGE SIZE (in/mm)	CLOSURE PART NUMBER	GASKET PART NUMBER
4 (101)	075-46450-004	028-10385-010
6 (152)	075-46450-006	028-10385-012
8 (202)	075-46450-008	028-10385-013
10 (254)	075-46450-010	028-10385-014
12 (305)	075-46450-012	028-10385-015
14 (355)	075-46450-014	028-10385-016
16 (406)	075-46450-016	028-10385-017

300 lbs. (112 kg) WATER FLANGE CLOSURES		
FLANGE SIZE (in/mm)	CLOSURE PART NUMBER	GASKET PART NUMBER
4 (101)	075-46450-104	028-10385-010
6 (152)	075-46450-106	028-10385-012
8 (202)	075-46450-108	028-10385-013
10 (254)	075-46450-110	028-10385-014
12 (305)	075-46450-112	028-10385-015
14 (355)	075-46450-114	028-10385-016
16 (406)	075-46450-116	028-10385-017

FIGURE 3 - COOLER CLOSURES

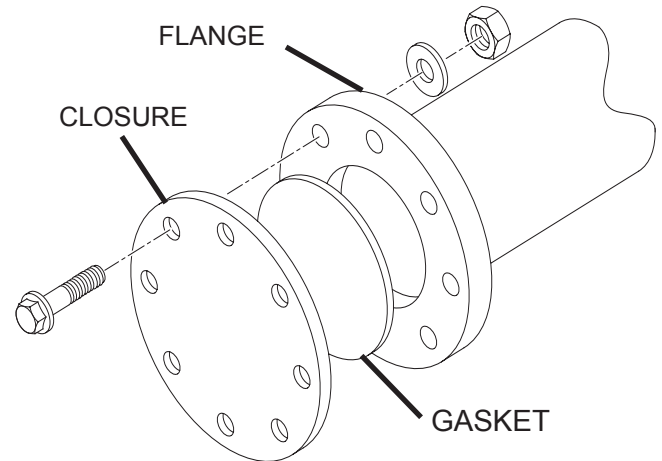

FIGURE 4 - FLANGE CLOSURES (4 IN. SHOWN)

NOTE: Not all flange closures use the same bolt pattern or the same quantity of hardware.



P.O. Box 1592, York, Pennsylvania USA 17405-1592
Copyright © by Johnson Controls 2011

800-861-1001
www.johnsoncontrols.com

Subject to change without notice. Printed in USA
ALL RIGHTS RESERVED

Form 50.20-NM9 (1011)
Issue Date: October 10, 2011
SUPERSEDES 50.20-NM9 (0806)