



New Release

Form 201.30-PW2 (312)

**FIELD CONNECTIONS AND CONTROL
WIRING FOR YVWA CHILLER**

WIRING DIAGRAM

CONTRACTOR _____
ORDER NO. _____
YORK CONTRACT NO. _____
YORK ORDER NO. _____

PURCHASER _____
JOB NAME _____
LOCATION _____
ENGINEER _____

REFERENCE DATE _____

APPROVAL DATE _____

CONSTRUCTION DATE _____

JOB DATA:

CHILLER PIN NOS. 1-4: YVWA

VSD FRAME SIZE (A, B, C, or D) _____

RUNNING LOAD AMPS (RLA) _____

POWER SUPPLY VOLTAGE _____

AUTOTRANSFORMER _____ YES _____ NO

CIRCUIT BREAKER _____ YES _____ NO

DISCONNECT SWITCH _____ YES _____ NO

IMPORTANT!

READ BEFORE PROCEEDING!

GENERAL SAFETY GUIDELINES

This equipment is a relatively complicated apparatus. During installation, operation maintenance or service, individuals may be exposed to certain components or conditions including, but not limited to: refrigerants, materials under pressure, rotating components, and both high and low voltage. Each of these items has the potential, if misused or handled improperly, to cause bodily injury or death. It is the obligation and responsibility of operating/service personnel to identify and recognize these inherent hazards, protect themselves, and proceed safely in completing their tasks. Failure to comply with any of these requirements could result in serious damage to the equipment and the property in

which it is situated, as well as severe personal injury or death to themselves and people at the site.

This document is intended for use by owner-authorized operating/service personnel. It is expected that these individuals possess independent training that will enable them to perform their assigned tasks properly and safely. It is essential that, prior to performing any task on this equipment, this individual shall have read and understood this document and any referenced materials. This individual shall also be familiar with and comply with all applicable governmental standards and regulations pertaining to the task in question.

SAFETY SYMBOLS

The following symbols are used in this document to alert the reader to specific situations:



Indicates a possible hazardous situation which will result in death or serious injury if proper care is not taken.



Identifies a hazard which could lead to damage to the machine, damage to other equipment and/or environmental pollution if proper care is not taken or instructions are not followed.



Indicates a potentially hazardous situation which will result in possible injuries or damage to equipment if proper care is not taken.

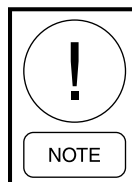

Highlights additional information useful to the technician in completing the work being performed properly.



External wiring, unless specified as an optional connection in the manufacturer's product line, is not to be connected inside the control cabinet. Devices such as relays, switches, transducers and controls and any external wiring must not be installed inside the micro panel. All wiring must be in accordance with Johnson Controls' published specifications and must be performed only by a qualified electrician. Johnson Controls will NOT be responsible for damage/problems resulting from improper connections to the controls or application of improper control signals. Failure to follow this warning will void the manufacturer's warranty and cause serious damage to property or personal injury.

CHANGEABILITY OF THIS DOCUMENT

In complying with Johnson Controls' policy for continuous product improvement, the information contained in this document is subject to change without notice. Johnson Controls makes no commitment to update or provide current information automatically to the manual owner. Updated manuals, if applicable, can be obtained by contacting the nearest Johnson Controls Service office.

Operating/service personnel maintain responsibility for the applicability of these documents to the equipment. If there is any question regarding the applicability of

these documents, the technician should verify whether the equipment has been modified and if current literature is available from the owner of the equipment prior to performing any work on the chiller.

CHANGE BARS

Revisions made to this document are indicated with a line along the left or right hand column in the area the revision was made. These revisions are to technical information and any other changes in spelling, grammar or formatting are not included.

ASSOCIATED LITERATURE

MANUAL DESCRIPTION	PART NUMBER
E-Link Gateway Installation Instructions	24-104-04-9 Rev. C

NOMENCLATURE

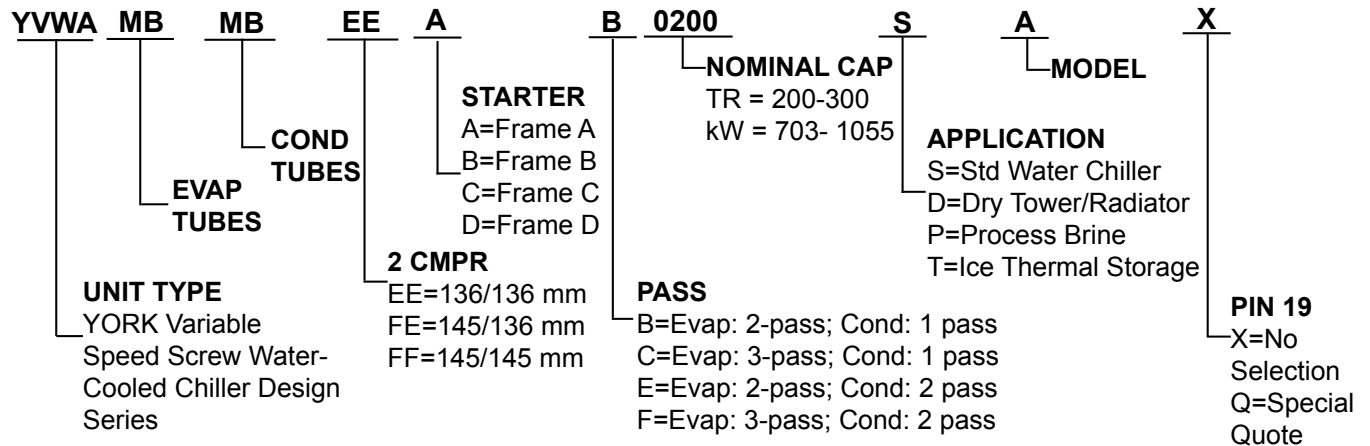

VARIABLE SPEED DRIVE NOMENCLATURE

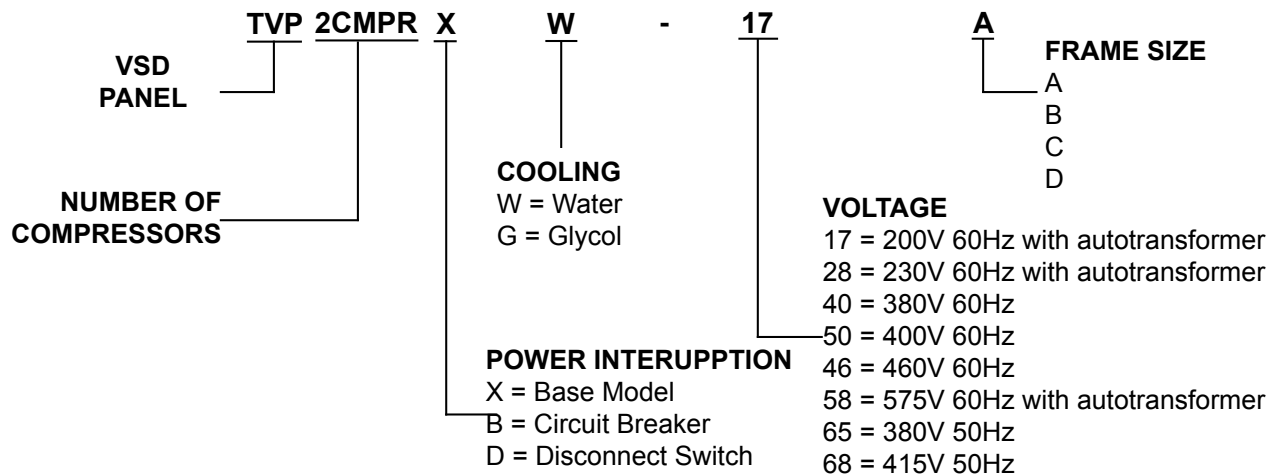







NOTES

TABLE 1 - NOTES FOR DRAWINGS

NO.	DESCRIPTION
1	All field wiring shall be in accordance with the relevant electrical code as well as all other applicable codes and specifications.
2	Contacts must be suitable for switching 115VAC at 5 MA.
3	Contacts are rated at 115V, 100VA, resistive load only, and must be suppressed at load by user.
4	See installation, operation and maintenance manual when optional equipment is used.
5	Not applicable
6	Not applicable
7	Applied to models ending in 65B, 65C, 50B, 50C, 68B, 68C, and all models ending in D.
8	Fuses -F(4FU & 5FU) are 12 A for 380V, 400V and 415V models.
9	Fuses F(4FU & 5FU) are 10 A for 200V, 230V, 460V and 575V models. Fuses F(1FU, 2FU and 3FU) are 800 A for models ending in C. Fuses F(1FU, 2FU and 3FU) are 900 A for models ending in 46D and 58D. Fuses F(1FU, 2FU and 3FU) are 1000 A for models ending in 40D, 65D, 50D, and 68D.
10	See Detail B for units with autotransformer.
11	Not applicable.
12	For Detail E for CE units.
13	Options not applicable to all units, remote temp reset, remote current limit.
14	Not applicable.
15	For models ending in A or B - AGDB P/N is 031-02061-003. For models ending in C OR D - AGDB P/N is 031-02061-001.
16	Accessory E-Link Gateway consisting of AMGB (cannot be used with RCC accessory)
17	Not applicable.
18	Not applicable.
19	Models ending in A get capacitors C1, C5, C2 and C6. Models ending in B and C get capacitors C1, C3, C5, C2, C4 and C6. Models ending in D get capacitors C1, C3, C5, C7, C2, C4, C6 and C8.
20	See Detail C for optional circuit breaker or disconnect switch.

For information on the notes in the following wiring diagrams not listed here, refer to the notes legend on the language kit that ships with the unit, which is located on the inside of the panel door.

LEGEND

- ES Transient Voltage Suppression
-  Terminal Block for Customer Connections (1TB)
-  Terminal Block for YORK Connections
-  Wiring Components by YORK
-  Optional Equipment
-  Wiring and/or Components by Others
-  NB Note Well
-  EXT A Component Marked Thus is External to the Control Panel

***=NOT REQUIRED FOR ALL MODELS**

LIST OF FIGURES

FIGURE 1 - Control Elementary Diagram	6
FIGURE 2 - Control Elementary Diagram	8
FIGURE 3 - Power Elementary Diagram.....	10
FIGURE 4 - Control Wiring - Connection Diagram.....	12
FIGURE 5 - Power Wiring - Connection Diagram	14
FIGURE 6 - Panel Layout.....	16
FIGURE 7 - Field Connections.....	20
FIGURE 8 - Power Wiring	22
FIGURE 9 - System 1 Compressor Electrical Assembly	24
FIGURE 10 - System 2 Compressor Electrical Assembly	26
FIGURE 11 - Connector Wiring Of HpcO.....	27

CONTROL ELEMENTARY DIAGRAM (CONT'D)

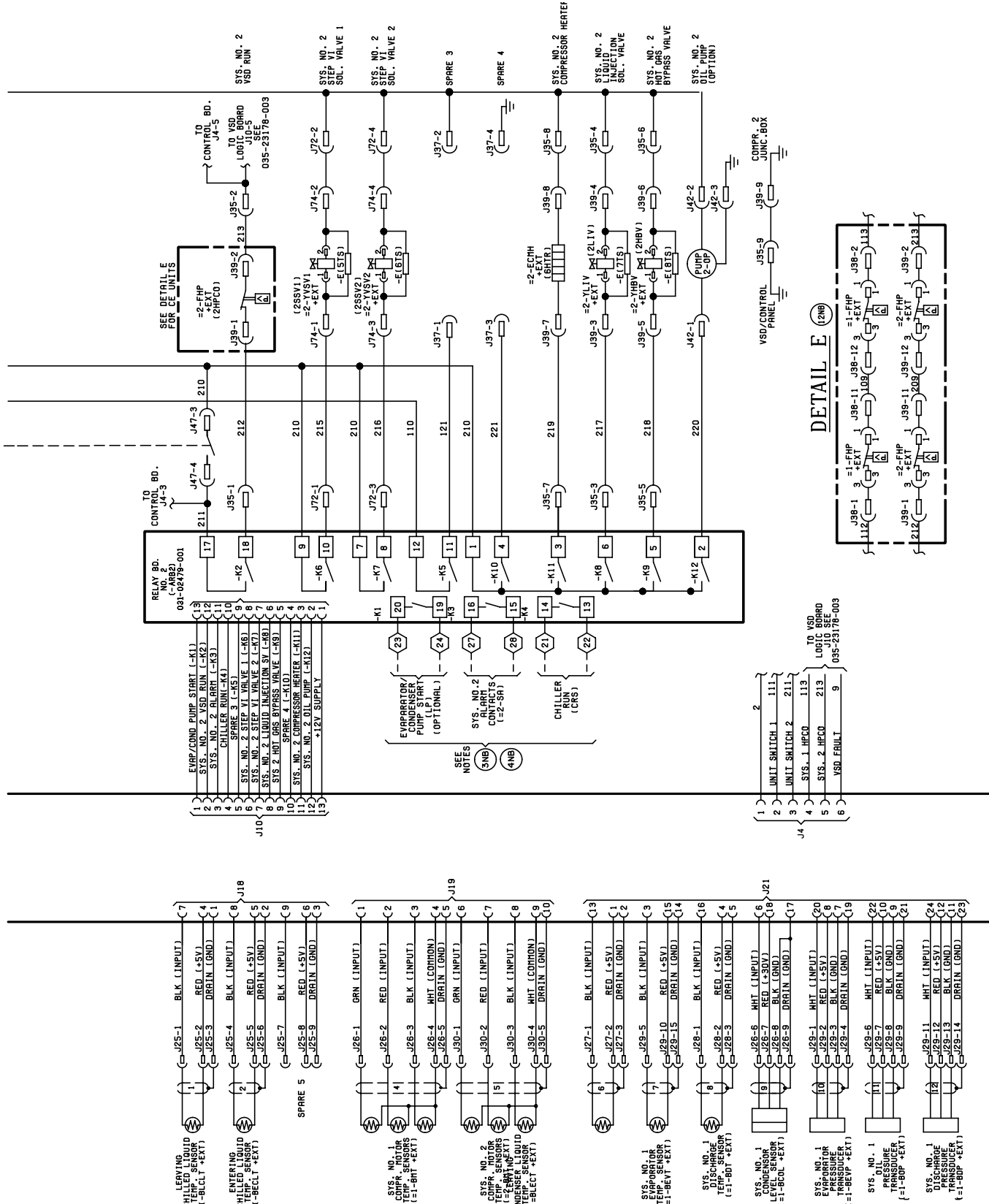

CONTROL ELEMENTARY DIAGRAM
 2 COMP VSD CHILLER
 035-23178-001 REV C

FIGURE 1 - CONTROL ELEMENTARY DIAGRAM (CONT'D)

CONTROL ELEMENTARY DIAGRAM (CONT'D)

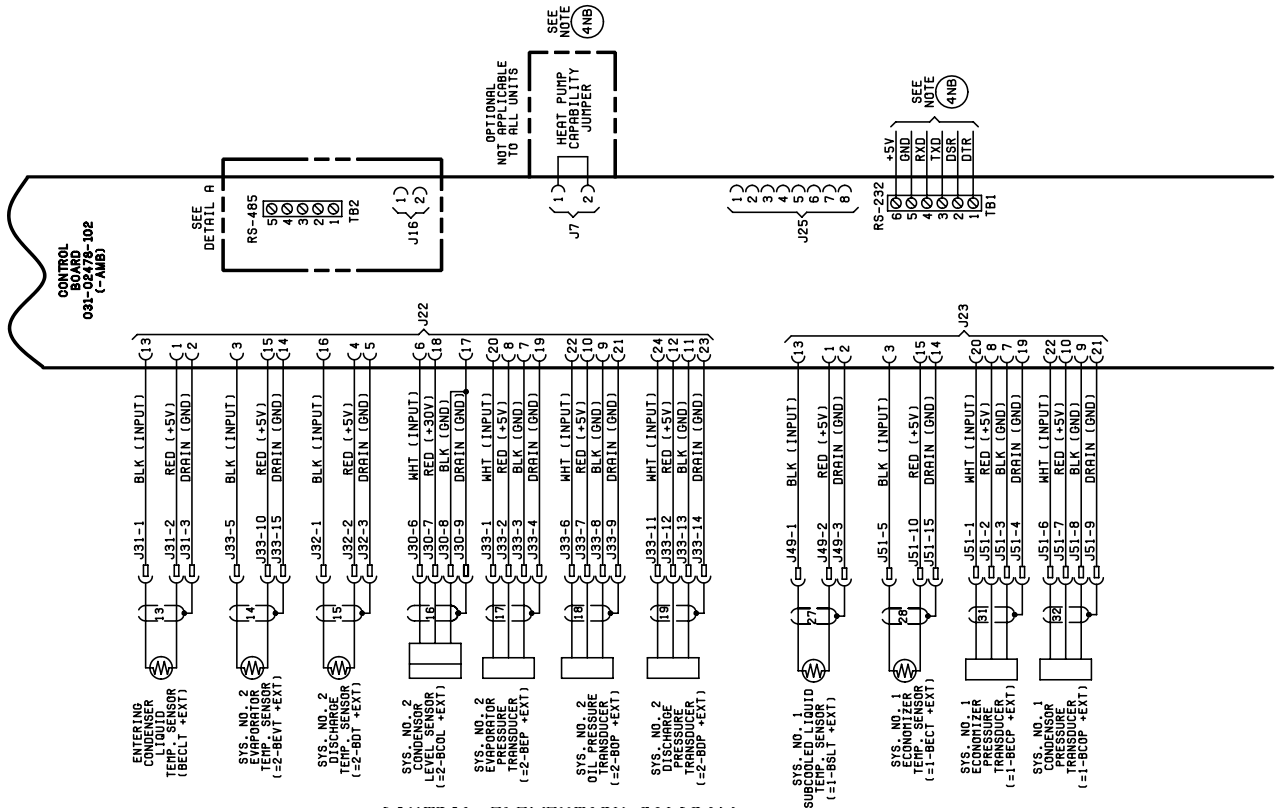

CONTROL ELEMENTARY DIAGRAM
 2 COMP VSD CHILLER
 035-23178-001 REV B

LD16130a

FIGURE 2 - CONTROL ELEMENTARY DIAGRAM

CONTROL ELEMENTARY DIAGRAM (CONT'D)

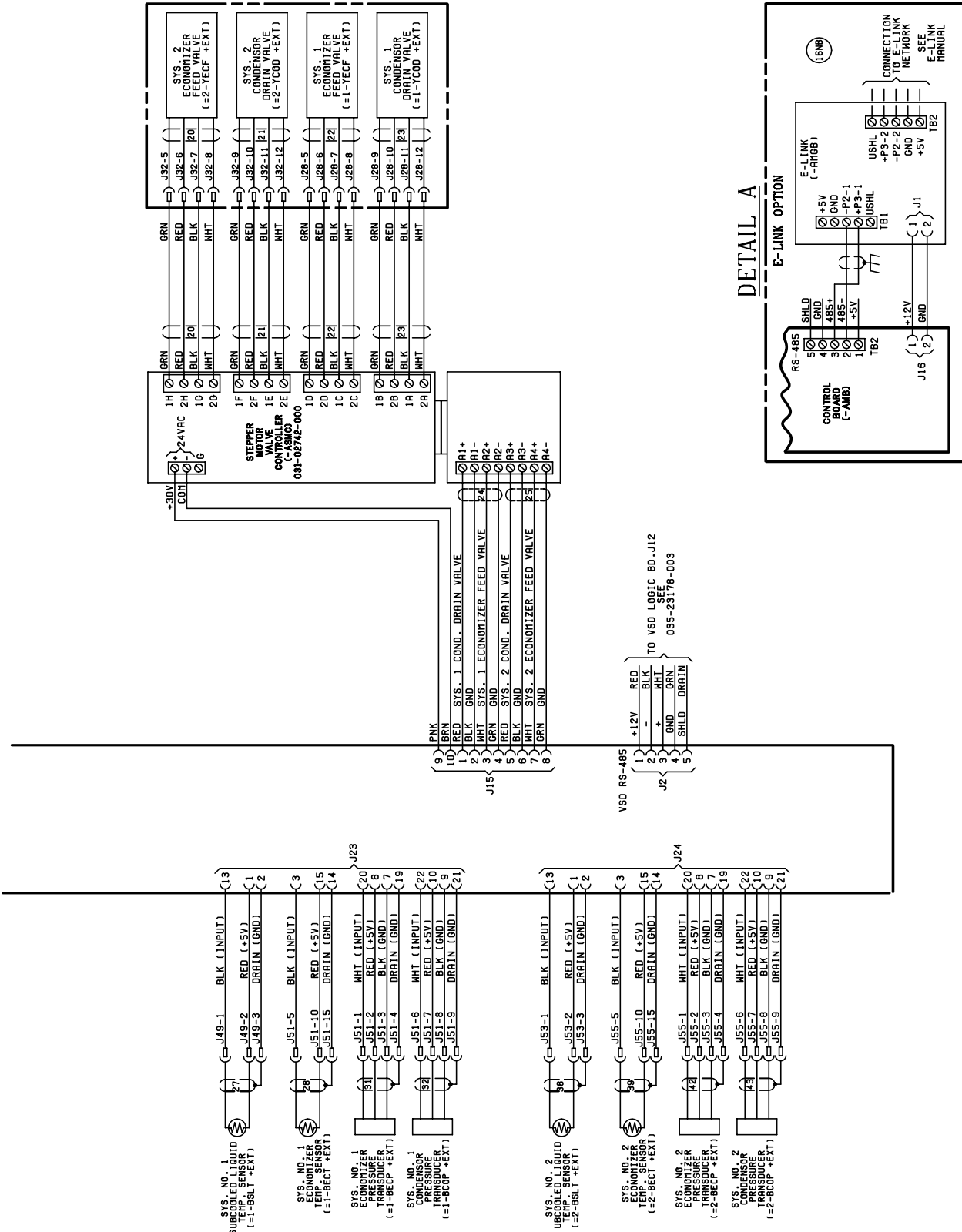

DETAIL A

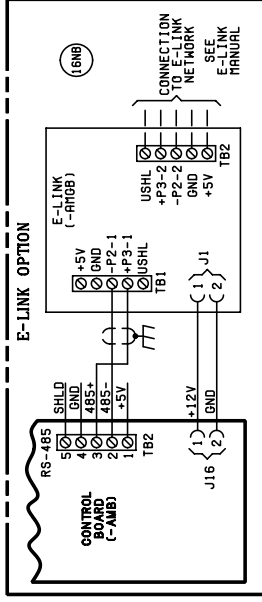
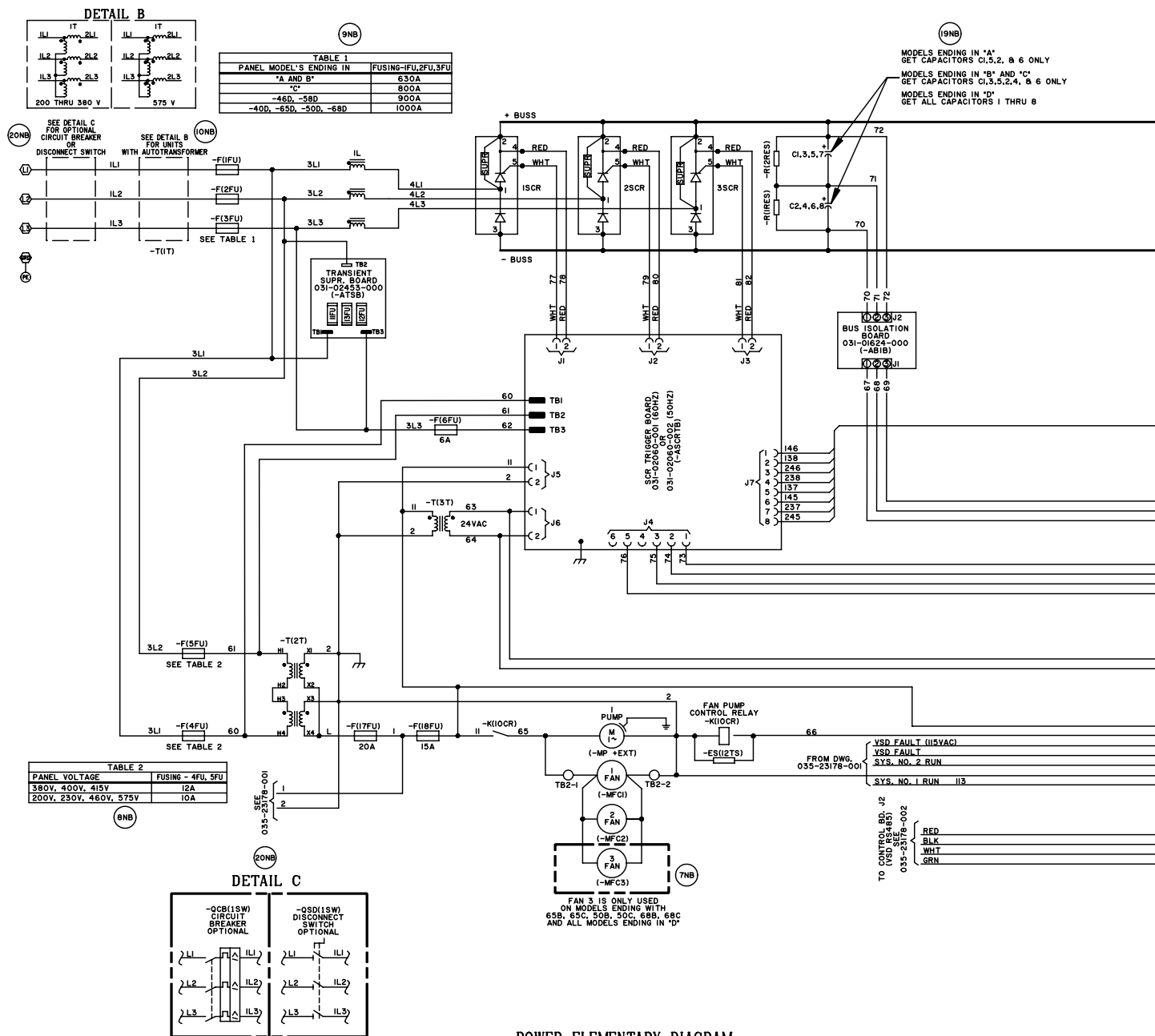

FIGURE 2 - CONTROL ELEMENTARY DIAGRAM – (CONT'D)

POWER ELEMENTARY DIAGRAM



POWER ELEMENTARY DIAGRAM
 2 COMPR VSD CHILLER
 035-23178-003 REV C

LD16131a

FIGURE 3 - POWER ELEMENTARY DIAGRAM

POWER ELEMENTARY DIAGRAM (CONT'D)

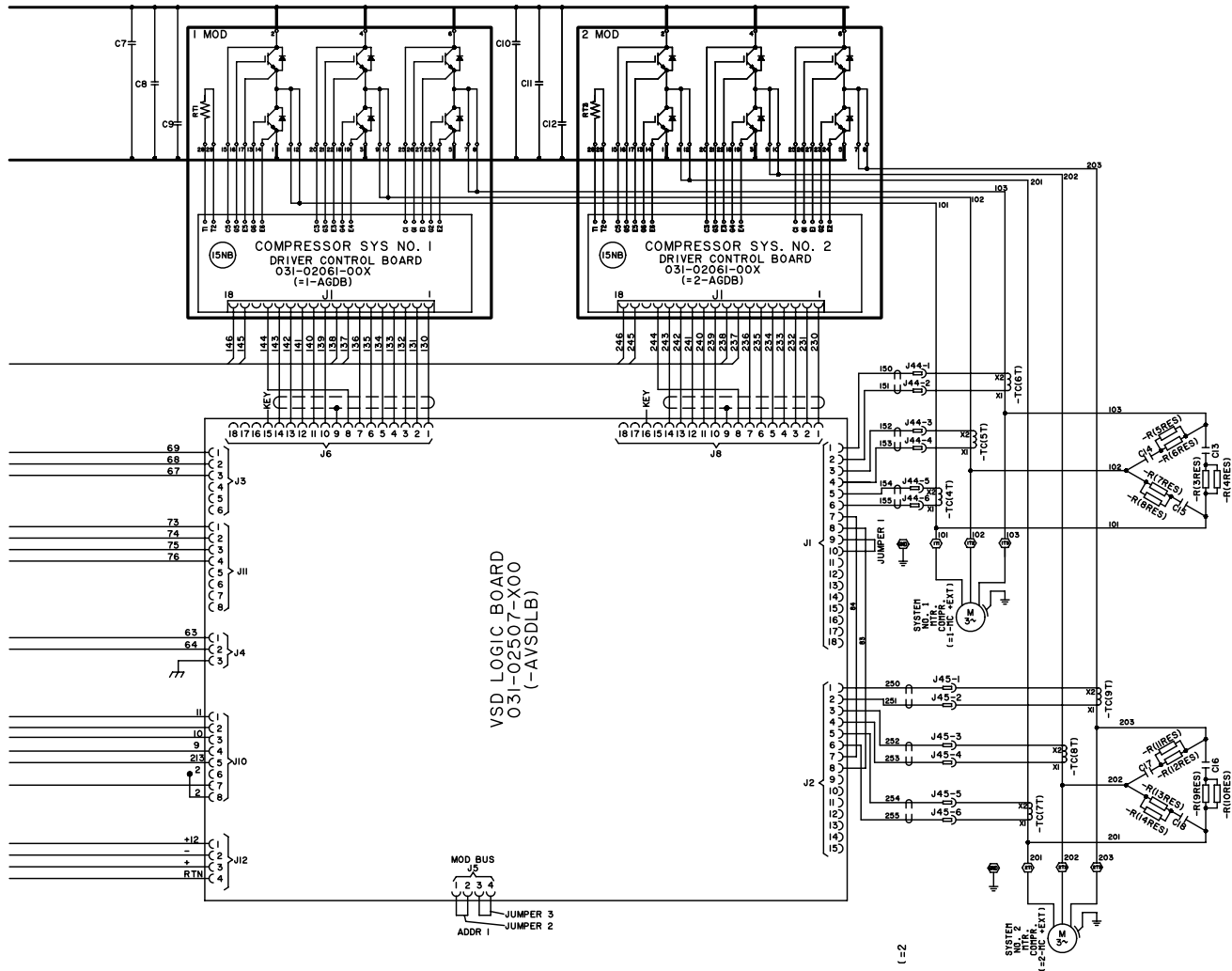

POWER ELEMENTARY DIAGRAM
 2 COMPR VSD CHILLER
 035-23178-003 REV C

LD16131b

FIGURE 3 - POWER ELEMENTARY DIAGRAM – (CONT'D)

CONTROL WIRING - CONNECTION DIAGRAM (CONT'D)

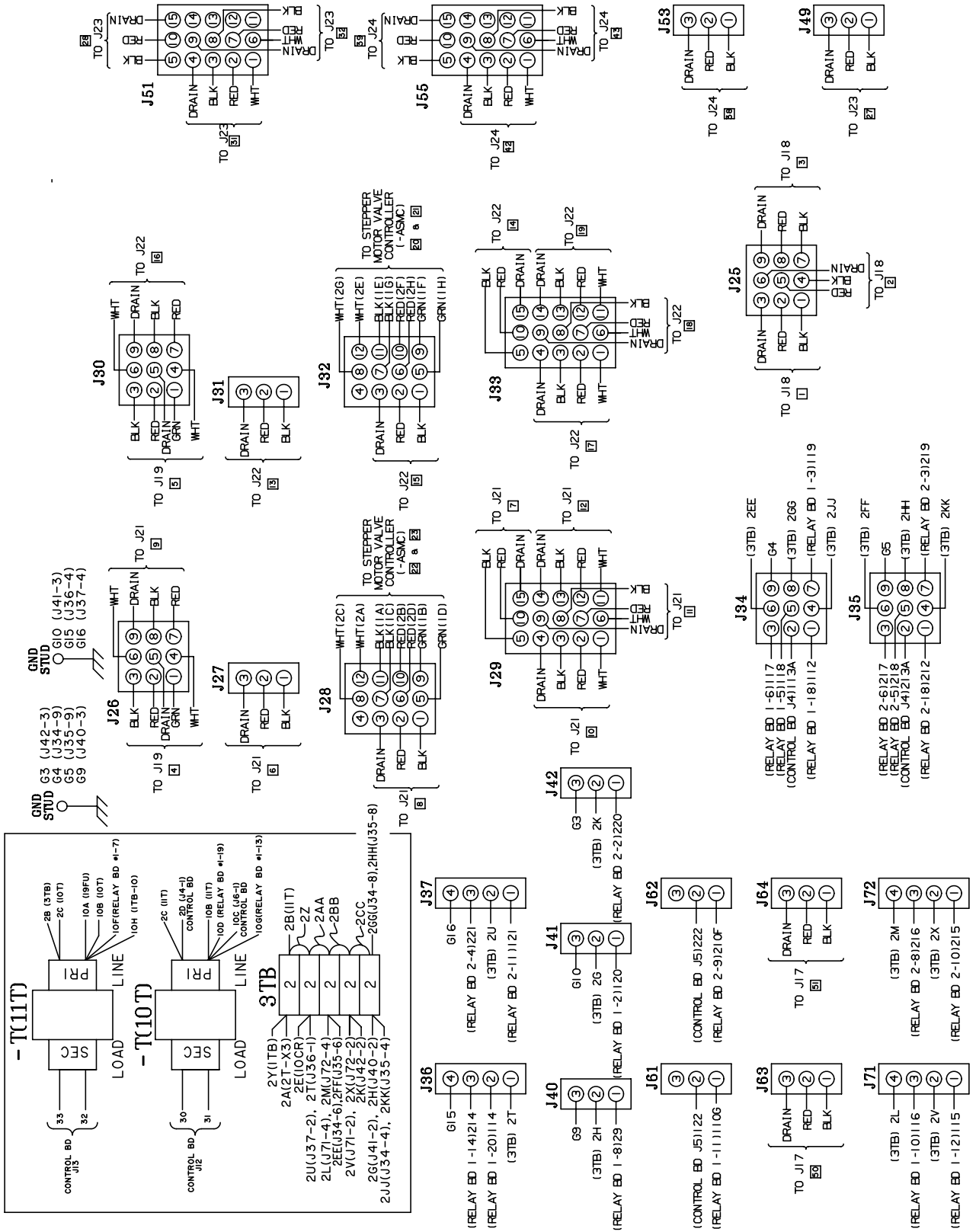

CONTROL WIRING - CONNECTION DIAGRAM
 2 COMPR VSD CHILLER
 035-23178-004 REV C

FIGURE 4 - CONTROL WIRING - CONNECTION DIAGRAM - (CONT'D)

PANEL LAYOUT

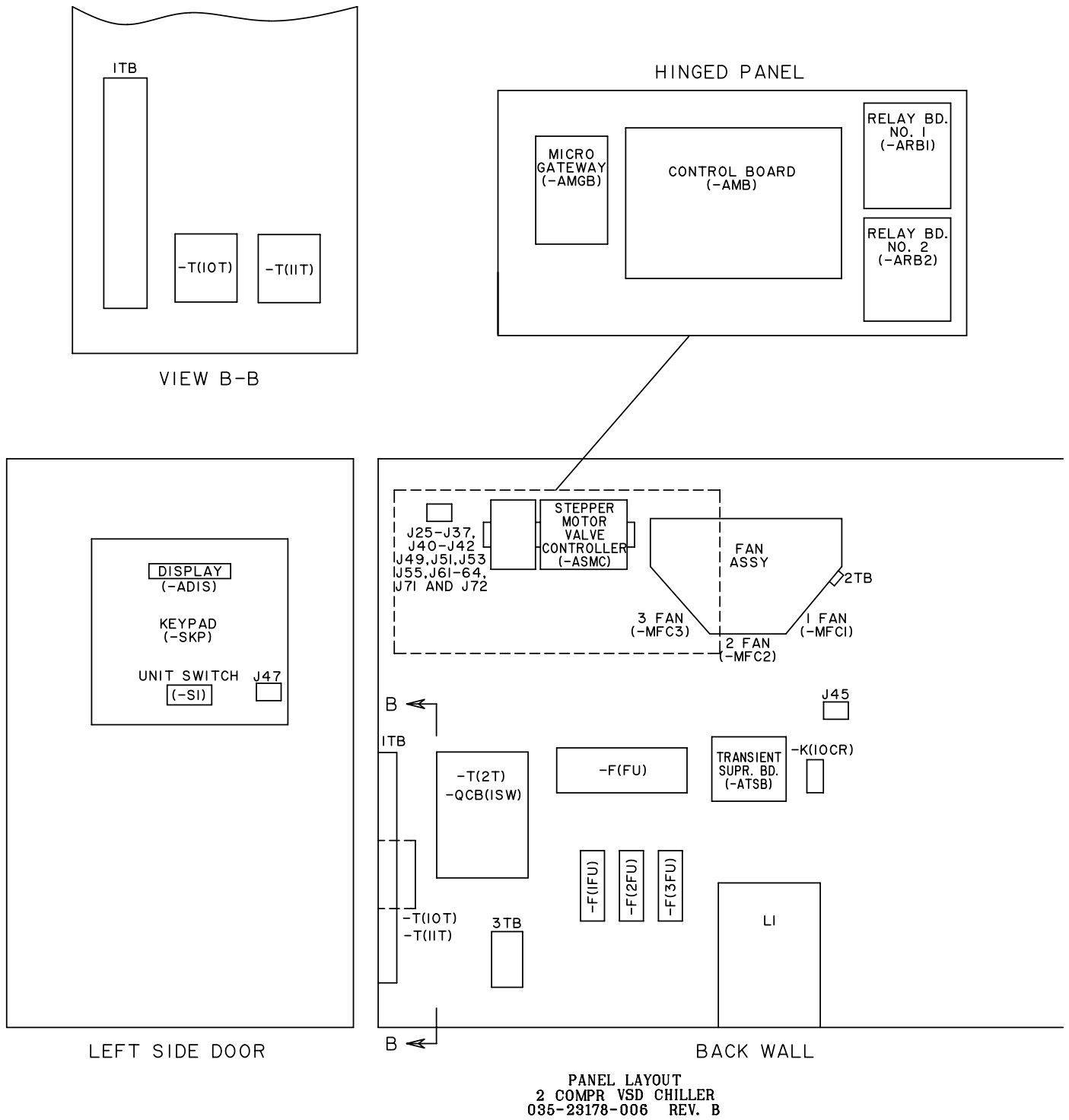

LD16134a

FIGURE 6 - PANEL LAYOUT

PANEL LAYOUT (CONT'D)

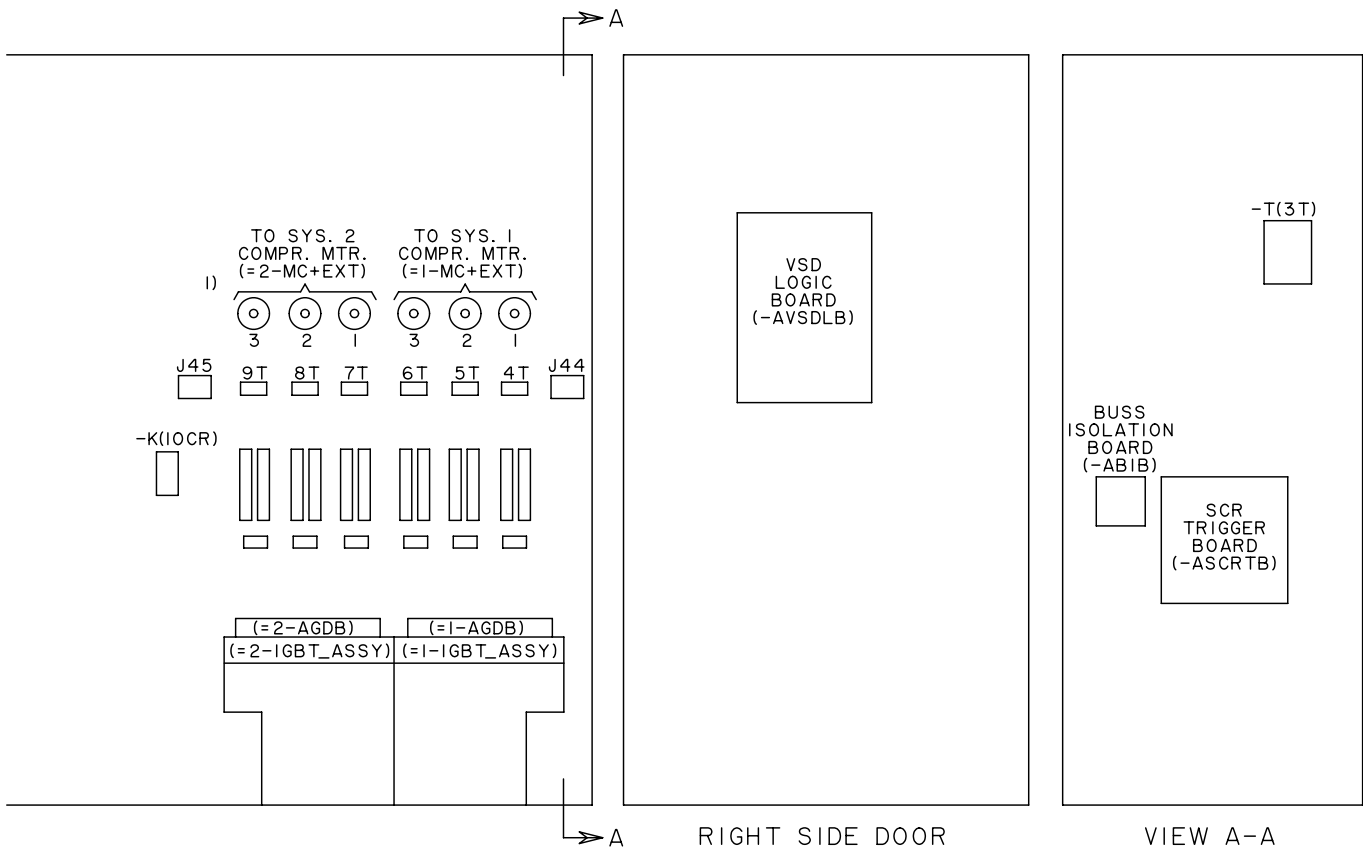

PANEL LAYOUT
 2 COMPR VSD CHILLER
 035-23178-006 REV. B

LD16134b

FIGURE 6 - PANEL LAYOUT - (CONT'D)

THIS PAGE INTENTIONALLY LEFT BLANK.

FIELD CONNECTIONS

NOTES

1. All field wiring shall be in accordance with the current edition of the relevant electric code as well as other applicable codes and specifications.
2. The Variable Speed Drive (VSD) shall be grounded in accordance with the related standards.
3. The branch circuit over current protection device for the YORK VSD must be a time delay type with a rating, which is the standard fuse/circuit breaker size required to protect the field supply wiring conductors per the relevant electric code as well as other applicable codes and specifications.
4. The main power transformer should be adequately sized such that the transformer voltage does not exceed 10% during unit start-up.
5. The YORK VSD power supply wiring ampacity shall be calculated as follows: Model YVWA Minimum Circuit Ampacity: 1.25 (JOB FLA) where $125 \text{ X (System 1 (RLA0) + (System 2 RLA0) + control transformer amps)}$.
6. A removable cover plate with pilot knockouts is supplied for connection of power supply conduits.
7. Each field-conducted inductive load, i.e. relay coil, motor starter coil, etc. shall have a transient suppressor wired (by others) in parallel with its coil, physically located at the coil.
8. Control wiring and input power wiring out the VSD/Control Panel by the customer.
9. Water pump and cooling fan are the customer's equipment, referenced only as wiring here.
10. The autotransformer is an option, which is used only for a 200V/3P/60 Hz, 230/3P/60 Hz or 575V/3P/60 Hz power system. For additional information such as weight, size, wiring lugs, and the installation location, contact the Johnson Controls application engineer for your project.

FIELD CONNECTIONS

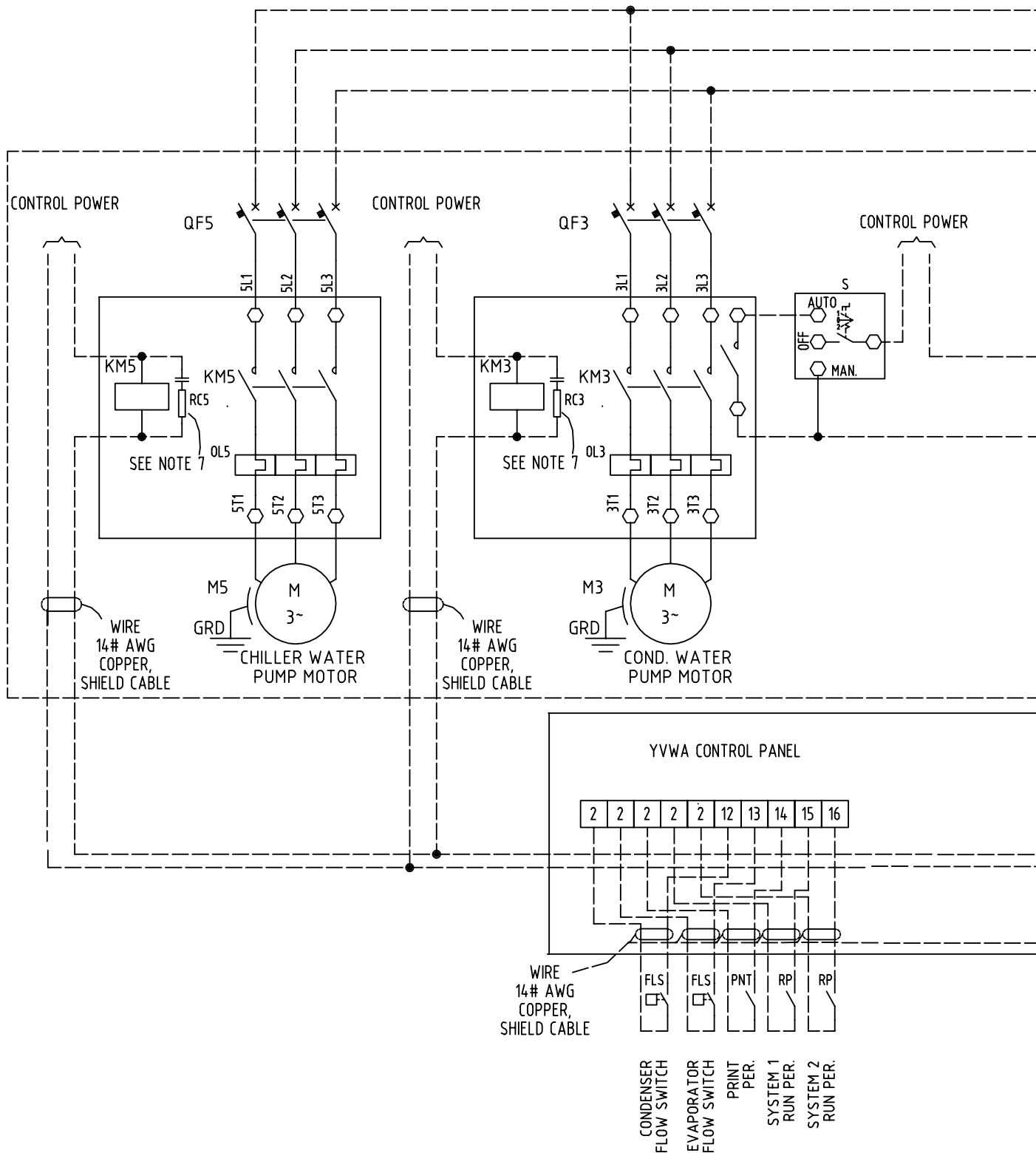

LD16135a

FIGURE 7 - FIELD CONNECTIONS

FIELD CONNECTIONS (CONT'D)

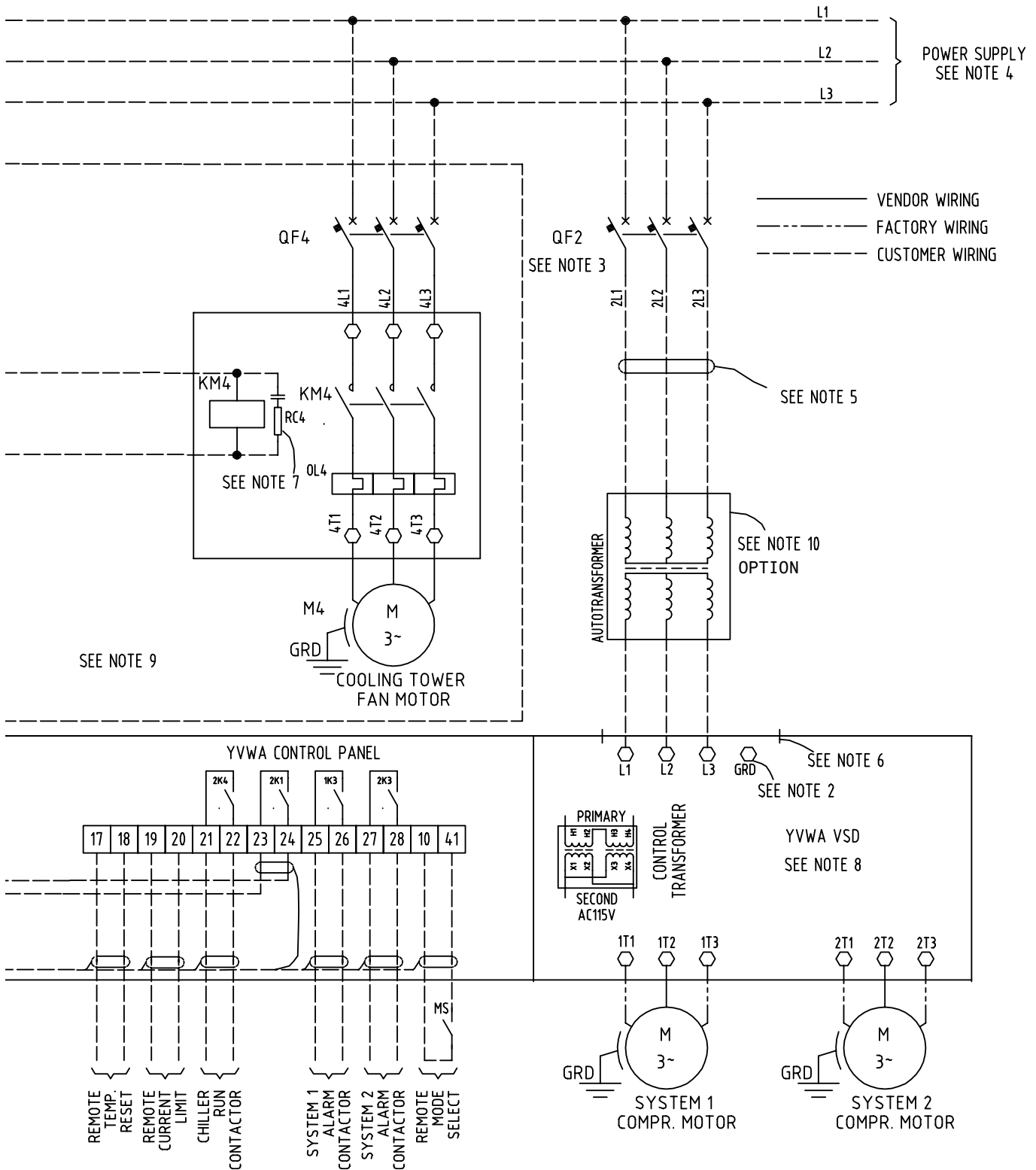

LD16135b

FIGURE 7 - FIELD CONNECTIONS – (CONT'D)

POWER WIRING

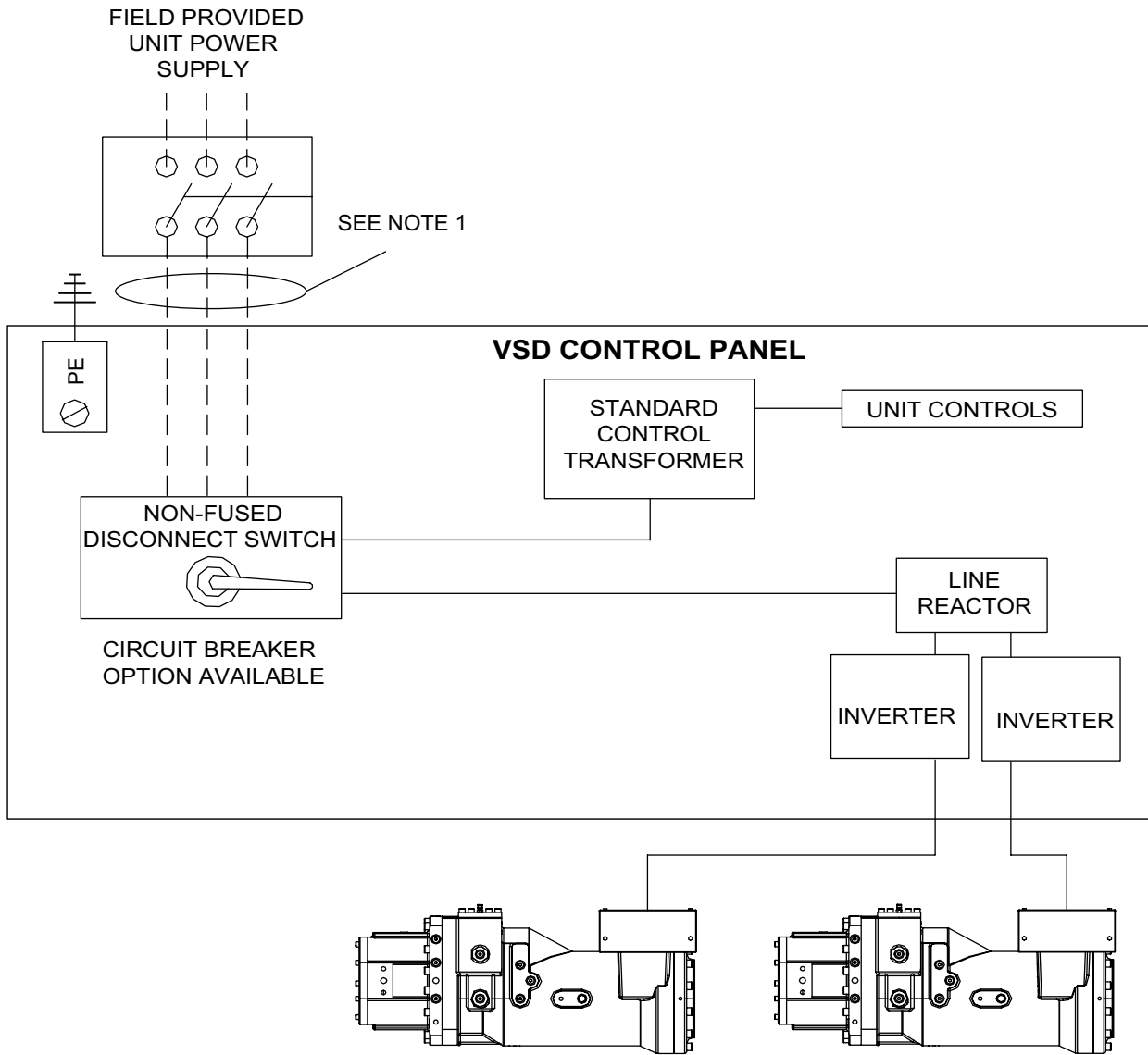

NOTES:

- 1. ----- Dashed Line = Field Provided Wiring

LD16136

FIGURE 8 - POWER WIRING

THIS PAGE INTENTIONALLY LEFT BLANK.

COMPRESSOR ELECTRICAL ASSEMBLY (CONT'D)

TABLE A

SYS 1 COMPRESSOR SUB WIRING(CONNECTS TO CONTROL DEVICES)																				
CAP DETAIL	CAP P/N	CAP "J" NO.	GB&UL			CE (DUAL HPCO)														
			CAP PIN NO.	WIRE NUMBER	FUNCTION	CAP PIN NO.	WIRE NUMBER	FUNCTION												
<table border="1" style="border-collapse: collapse; width: 100%;"> <tr><td style="text-align: center;">1</td><td style="text-align: center;">2</td><td style="text-align: center;">3</td></tr> <tr><td style="text-align: center;">4</td><td style="text-align: center;">5</td><td style="text-align: center;">6</td></tr> <tr><td style="text-align: center;">7</td><td style="text-align: center;">8</td><td style="text-align: center;">9</td></tr> <tr><td style="text-align: center;">10</td><td style="text-align: center;">11</td><td style="text-align: center;">12</td></tr> </table>	1	2	3	4	5	6	7	8	9	10	11	12	025-20787-000 (WHITE)	J38	1	112	SYS1 HPCO	1	112	SYS1 HPCO1
	1	2	3																	
	4	5	6																	
	7	8	9																	
	10	11	12																	
	2	113	2	109																
	3	117	SYS1 LIO. INJEC. VALVE	3	117	SYS1 LIO. INJEC. VALVE	4	2												
	4	2		5	118		SYS1 HGBP VALVE	6	2											
	5	118	SYS1 HGBP VALVE	7	119	SYS1 COMPR. HEATER		7	119											
	6	2		8	2		8	2												
	7	119	SYS1 COMPR. HEATER	9	GND	N/A	9	GND												
	8	2		10			10		NA											
9	GND	N/A	11		N/A	11	113	SYS1 HPCO2												
10			12			12	109													
11																				
<table border="1" style="border-collapse: collapse; width: 100%;"> <tr><td style="text-align: center;">4</td><td style="text-align: center;">3</td><td style="text-align: center;">2</td><td style="text-align: center;">1</td></tr> </table>	4	3	2	1	025-21756-000 (WHITE)	J73 (OPTION)	1	115	SYS1 STEP VI VALVE1	1	115	SYS1 STEP VI VALVE1								
	4	3	2	1																
	2	2	2	2																
	3	116	SYS1 STEP VI VALVE2	3			116	SYS1 STEP VI VALVE2	4	2										
4	2	4		2																

LD16464

FIGURE 9 - SYSTEM 1 COMPRESSOR ELECTRICAL ASSEMBLY (CONT'D)

COMPRESSOR ELECTRICAL ASSEMBLY

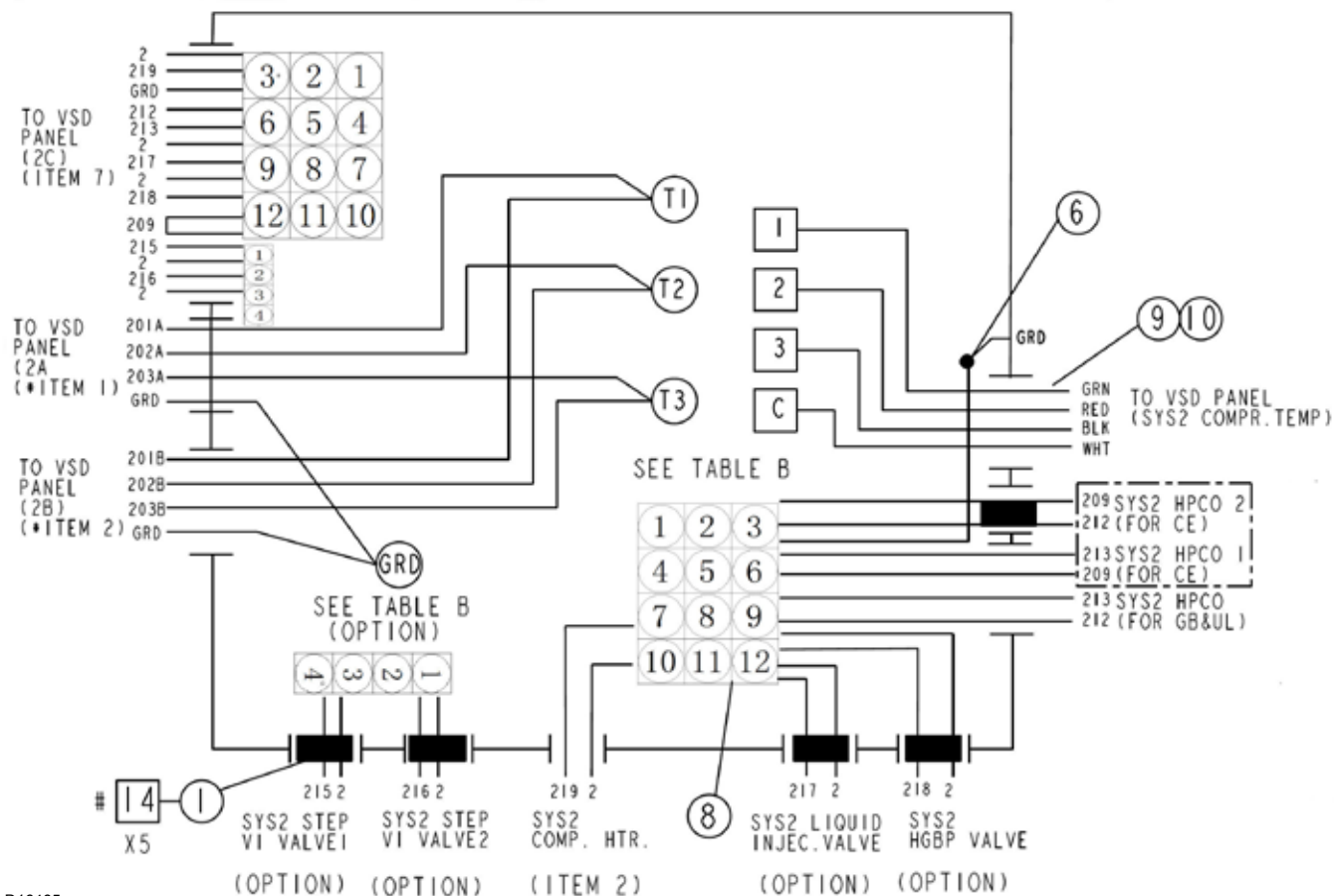

LD16465

FIGURE 10 - SYSTEM 2 COMPRESSOR ELECTRICAL ASSEMBLY

COMPRESSOR ELECTRICAL ASSEMBLY (CONT'D)

TABLE B

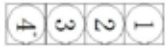
SYS2 COMPRESSOR SUB WIRING(CONNECTS TO CONTROL DEVICES)								
CAP DETAIL	CAP P/N	CAP "J"NO.	GB&UL			CE (DUAL HPCO)		
			CAP PIN NO.	WIRE NUMBER	FUNCTION	CAP PIN NO.	WIRE NUMBER	FUNCTION
	025-20787-000 (WHITE)	J39	1	212	SYS2 HPCO	1	212	SYS2 HPCO1
			2	213		2	209	
			3	217	SYS2 LIO. INJEC. VALVE	3	217	SYS2 LIO. INJEC. VALVE
			4	2		4	2	
			5	218	SYS2 HGBP VALVE	5	218	SYS2 HGBP VALVE
			6	2		6	2	
			7	219	SYS2 COMPR. HEATER	7	219	SYS2 COMPR. HEATER
			8	2		8	2	
			9	GND		9	GND	
			10		N/A	10		N/A
			11			11	213	SYS2 HPCO2
			12			12	209	
	025-21756-000 (WHITE)	J74 (OPTION)	1	215	SYS2 STEP VI VALVE1	1	215	SYS2 STEP VI VALVE1
			2	2		2	2	
			3	216	SYS2 STEP VI VALVE2	3	216	SYS2 STEP VI VALVE2
			4	2		4	2	

LD16465

FIGURE 10 - SYSTEM 2 COMPRESSOR ELECTRICAL ASSEMBLY (CONT'D)

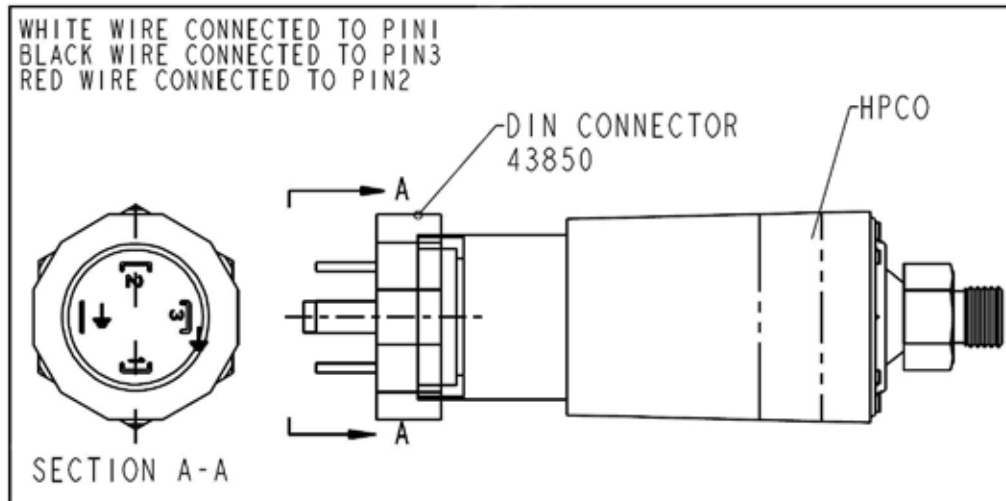

LD16466

FIGURE 11 - CONNECTOR WIRING OF HPCO



P.O. Box 1592, York, Pennsylvania USA 17405-1592
Copyright © by Johnson Controls 2012
Form 201,30-PW2
Issue Date: March 26, 2012
NEW RELEASE

800-861-1001
www.johnsoncontrols.com

Subject to change without notice. Printed in USA
ALL RIGHTS RESERVED