



BY JOHNSON CONTROLS



***Model YVWA Variable-Speed, Water-Cooled Screw  
Compressor Chillers***

120-300 Tons  
420-1055 kW  
1 or 2 Compressors  
50 and 60Hz  
HFC-134a



# Nomenclature

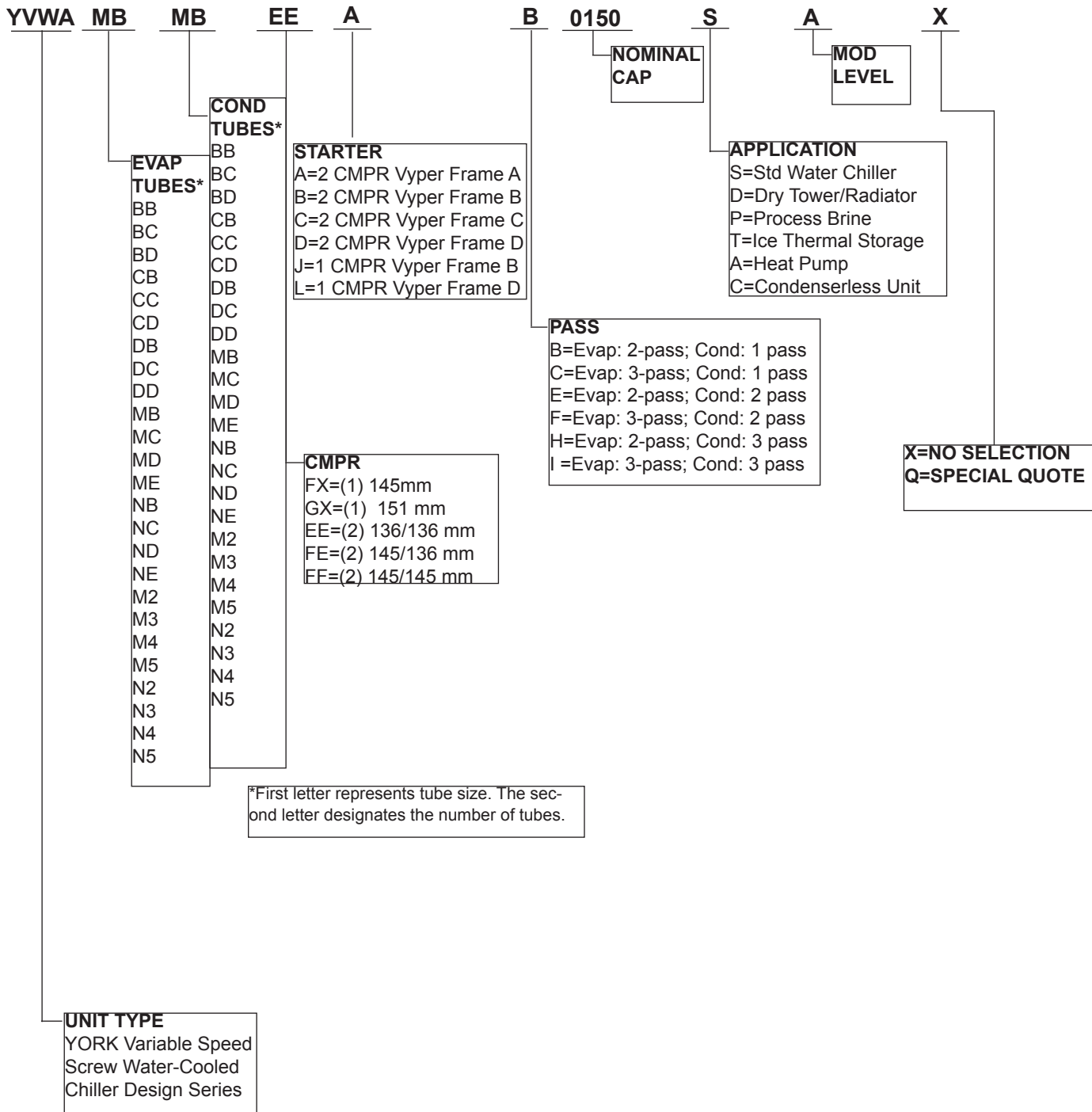

# **Table of Contents**

<b>Nomenclature.....</b>	<b>2</b>
<b>Introduction.....</b>	<b>4</b>
<b>Equipment Overview.....</b>	<b>6</b>
<b>MicroComputer Control Center.....</b>	<b>7</b>
<b>Accessories and Options .....</b>	<b>8</b>
<b>Unit Components - Front View .....</b>	<b>10</b>
<b>Unit Components - Back View.....</b>	<b>11</b>
<b>Dimensions - Unit.....</b>	<b>12</b>
<b>Dimension – Floor Layout - Neoprene Pad.....</b>	<b>18</b>
<b>Dimension – Floor Layout - Spring Isolator.....</b>	<b>20</b>
<b>Weights.....</b>	<b>22</b>
<b>Electrical Data.....</b>	<b>22</b>
<b>Control Wiring.....</b>	<b>24</b>
<b>Power Wiring.....</b>	<b>26</b>
<b>Application Data .....</b>	<b>27</b>
<b>Guide Specifications .....</b>	<b>33</b>
<b>Unit Conversion.....</b>	<b>39</b>



For over 135 years, Johnson Controls has raised the bar of chiller design and customer expectations. We are raising the bar again with a leap forward in water-cooled screw compressor chiller technology. Continuing the history of innovation in both compressor design and variable speed drive (VSD) technology, Johnson Controls proudly introduces the YORK® YVWA.

The YORK YVWA chillers provide superior performance. Higher efficiency heat exchangers coupled with variable speed operation and smart controls elevate the system efficiency to a whole new level. The resulting benefit from YVWA is much greater than the sum of its parts.

### **Efficiency: Reduce your consumption**

YVWA chillers are Johnson Controls' most efficient water-cooled screw chillers. The design includes the latest technology such as hybrid falling-film evaporators to give the customer maximum efficiency and reduced refrigerant charge compared to previous flooded evaporator designs. With up to a 30% improvement in real world efficiency versus current products, YVWA sets the new standards for lowering energy use.

### **Flexibility: Designed for the customer**

The YVWA was designed with the customer in mind. YVWA chillers are capable of providing a variety of cooling and heating applications and are compatible with open- or closed-circuit cooling towers, dry air coolers, or adiabatic coolers. The YVWA's flexibility, including heat recovery and heat pump capability, makes it a perfect fit for all applications.

### **Sustainability: Improve your environmental footprint**

YVWA lowers both direct and indirect impact on the environment. It uses HFC-134a refrigerant which has zero ozone depletion potential (ODP). The design minimizes the quantity of refrigerant used in the system. Every YVWA model helps LEED projects earn the Energy and Atmosphere Credit 4. HVAC systems are one of the largest consumers of electricity in commercial buildings and the largest portion of green house gasses is created by carbon dioxide generated from electric power plants. YVWA chillers reduce the electricity usage, thereby contributing to reducing greenhouse gases and helping keep the planet cool.

### **Confidence: Proven performance provides peace of mind**

The YVWA design is proven by years of success with the previous generation of YORK VSD water-cooled screw chillers with thousands of machines operating in more than one hundred countries.

YVWA is configurable to be the perfect fit for your unique needs. YVWA offers an array of options that can be tailored and tuned to match the capacity, efficiency sound and footprint for your specific application. Several variations of condenser and evaporator arrangements, alternative compressor head ratios, sound reduction kits, and controls schemes are available to meet specific requirements for your site.



Rated in accordance with the latest issuance of AHRI Standards 550/590 and 551/591.

### **AHRI CERTIFICATION PROGRAM**

The performance of the YORK YVWA chiller has been certified to the Air Conditioning, Heating, and Refrigeration Institute (AHRI) as complying with the certification sections of the latest issue of AHRI Standards 550/590 and 551/591. Under this Certification Program, chillers are regularly tested in strict compliance with these Standards. This provides an independent, third-party verification of chiller performance.

### **COMPUTERIZED PERFORMANCE RATINGS**

Each chiller is custom-matched to meet the individual building load and energy requirements. A variety of standard heat exchangers and pass arrangements are available to provide the best possible match.

It is not practical to provide tabulated performance for each combination, as the energy requirements at both full and part load vary significantly with each unique component arrangement. Computerized ratings are available through each Johnson Controls sales office. Each rating can be tailored to specific job requirements, and is part of the AHRI Certification Program.

### **OFF-DESIGN PERFORMANCE**

Since the vast majority of its operating hours are spent

at off-design conditions, a chiller should be chosen not only to meet the full load design, but also for its ability to perform efficiently at lower loads. It is not uncommon for chillers with the same full load efficiency to have an operating cost difference of over 30% due to differences in off-design (part-load) efficiencies.

Part load information can be easily and accurately generated by use of the computer. And because it is so important to an owner's operating budget, this information has now been standardized within the AHRI Certification Program in the form of an Integrated Part Load Value (IPLV), and Non-Standard Part Load Value (NPLV).

The current IPLV/NPLV rating from AHRI Standards 550/590 and 551/591 much more closely tracks actual chiller operation, and provides a more accurate indication of chiller performance than the previous IPLV/APLV rating. A more detailed analysis must take into account actual building load profiles, and local weather data. Part load performance data should be obtained for each job using its own design criteria.

Chillers conform to the following Standards and Codes:

1. AHRI 550/590 and 551/591 - Water Chilling Packages using the Vapor Compression Cycle.
2. GB/T 18430.1 - Water Chilling (Heat Pump) Packages Using The Vapor Compression Cycle - Part 1: Water Chilling (Heat Pump) Packages For Industrial & Commercial And Similar Applications.
3. GB25131 - Safety Requirements For Water Chillers (Heat Pump) Using The Vapor Compression Cycle.
4. GB150/151 - Steel Pressure Vessels/Tubular Heat Exchangers.
5. ANSI/ASHRAE 34 - Number Designation And Safety Classification Of Refrigerants.
6. ASHRAE 90.1 - Energy Standard For Buildings Except Low-Rise Residential Buildings.
7. Machinery Directive (2006/42/EC)
8. EMC Directive (2004/108/EC)
9. Pressure Equipment Directive (97/23/EC)
10. Safety Code for Mechanical Refrigeration (EN 378-2)
11. Safety of machinery - Electrical Equipment of Machine (EN 60204-1)
12. Manufactured in an EN ISO 9001 accredited organization
13. ISO 9614 – Determination of sound power levels of noise sources using sound intensity
14. Conform to CE Testing Services for construction of chillers and provide CE Listed Mark

# Equipment Overview

## SEMI-HERMETIC YORK SCREW COMPRESSORS

The direct-drive, semi-hermetic rotary screw compressor incorporates advanced technology in a rugged design. The continuous function, microprocessor controlled VSD provides smooth capacity control from 100% down to 20% chiller capacity. State-of-the-art screw compressor design and manufacturing ensures optimal efficiencies at all chiller load points. With no unloading steps or slide valves in the compressor, the YVWA variable speed driven compressor has 50% fewer moving parts than fixed speed compressors with slide valves. The YVWA compressor is one of the most efficient and reliable screw compressors in the industry.

## EVAPORATOR

The evaporator is a shell and tube, hybrid falling film type heat exchanger. It contains a balance of flooded and falling film technology to optimize efficiency, minimize refrigerant charge, and maintain reliable control. A specifically designed distribution system provides uniform refrigerant flow for optimum performance.

## CONDENSER

The condenser is a shell and tube type, with a discharge gas baffle to prevent direct high velocity impingement on the tubes. The baffle is also used to distribute the refrigerant gas flow properly for the most efficient heat transfer. An integral sub-cooler is located at the bottom of the condenser shell providing highly effective liquid refrigerant subcooling to provide the highest cycle efficiency .

## REFRIGERANT CIRCUIT

The YVWA has one independent refrigerant circuit per compressor. An electronic expansion valve (EEV), controlled by the unit panel, accommodates varying head and load conditions. The condenser shell is capable of storing the entire system refrigerant charge during servicing. Optional service valves are available to facilitate the removal of refrigerant. The sub-cooling economizer (plate heat exchanger type), controlled by the unit panel, meters some refrigerant gas to the compressor to reduce energy consumption.

## COMPLETE FACTORY PACKAGE

Each unit is shipped as a complete factory package, completely assembled with all interconnecting refrigerant piping and internal wiring and ready for field installation. Prior to shipment, each individual chiller undergoes an extensive testing procedure, ensuring workmanship is the highest quality and that the initial start-up is trouble-free. Before leaving the factory, each refrigerant circuit is factory pressure tested, evacuated and then fully charged with HFC-134a refrigerant and oil. An operational test is performed with water flowing through the evaporator and condenser to ensure each circuit functions correctly.

## ELECTRICAL

All controls and motor starting equipment necessary for unit operation are factory wired and function tested. There are no surprises at start-up; the unit will start up right the first time and every time. The standard unit is equipped with circuit breaker for electrical connections. The chillers come with a single point power connection and are supplied with a factory mounted and wired control transformer that powers all unit controls from the main unit power supply. The transformer utilizes scheduled line voltage on the primary side and provides 115V/1Ø on secondary. All exposed power wiring is routed through liquid-tight, UV-stabilized, non-metallic conduit.

VSD Power/Control Panel includes main power connection(s), VSD contactors, current overloads, and factory wiring. All display and control features can be accessed through the keypad and control display access door, eliminating the need to open the main cabinet doors.

## BUILDING AUTOMATION SYSTEM CAPABILITIES

The E-Link Gateway provides an economical and versatile connection between Johnson Controls equipment and open/standard protocols. It efficiently manages the communication protocols currently used by Johnson Controls equipment, exposing the data in a consistent, organized, and defined fashion. A simple switch selection allows configuration of the required equipment profile and output protocol, which reduces equipment connectivity startup time

# MicroComputer Control Center

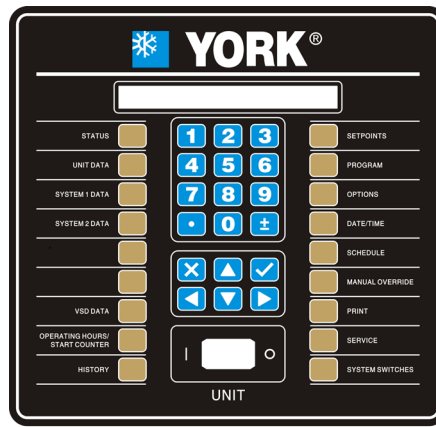

**FIGURE 1 – VIEW OF CONTROL CENTER KEYPAD AND DISPLAY**

The microcomputer control center provides automatic control of chiller operation including compressor start/stop and load/unload anti-recycle timers, chilled liquid pump, unit alarm contacts and run signal contacts. The microcomputer control center comes online as soon as the main power switch on the unit is switched on; immediately, the microcomputer control center will begin to continuously monitor all variables.

The microprocessor controls the unit's capacity by matching the actual leaving chilled liquid temperature (LCHLT) to the user-defined setpoint. Factors that may cause the system's actual LCHLT to fluctuate are changes in load, and chilled liquid loop flow rate and volume. The controls system logic monitors the rate at which the LCHLT is approaching the setpoint to ramp up or down compressor capacity as required. The variable frequency drive allows the compressor capacity to match the load.

### Display Data

- Leaving Chilled Liquid Temperature
- Returning Liquid Temperature
- Lead System (if applicable)
- Compressor Capacity (% of Full Load Amps)
- VSD Output Frequency / Compressor Speed
- Compressor Run Hours
- Compressor Number of Starts
- Oil Pressure
- History Data for Last Twenty Normal Shutdowns
- History Data for Last Ten Shutdown Faults

### Programmable Setpoints

- Display Language
- Chilled Liquid Cooling Mode
- Local or Remote Control
- Display Unit
- Remote Temperature Reset
- Remote Current Limit
- Leaving Chilled Liquid Setpoint and Range
- Maximum Remote Temperature Reset
- Leaving Condenser Liquid Setpoint and Range (Heat Pump Mode Only)

Johnson Controls' systems or another vendor's systems can incorporate these setpoints and data outputs to give the customer a complete understanding of how the system is running through a Building Automation System.

**Extreme Conditions** - During extreme or unusual conditions the chiller control system will avoid shut-down by varying capacity. By monitoring motor current and suction and discharge pressures, the chiller can maintain maximum available cooling output without shutting down.

Unit Safeties are provided for the chiller to perform auto-reset shut down for the following conditions:

- Out of range leaving chilled liquid temperature
- Under voltage
- Flow switch operation

# Accessories and Options

All options factory mounted unless otherwise noted.

## SOUND ATTENUATION

The standard chiller configuration is equipped with acoustic treatments on the refrigerant lines, compressors, and oil separators. There are several sound attenuation options available to further reduce sound at its source thereby meeting local sound level regulations.

## HEAT EXCHANGER OPTIONS

**FACTORY INSULATION OF EVAPORATOR** – Factory-applied thermal insulation of the flexible, closed-cell plastic type, 3/4" (19mm) thick is attached with vapor-proof cement to the evaporator shell, flow chamber, evaporator tube sheets, suction connection, water boxes and nozzles, and (as necessary) to the auxiliary tubing. Insulation can also be provided on the condenser if desired to meet specific application needs, such as heat recovery or heat pump duty. This insulation will normally prevent condensation in environments with relative humidity up to 75% and dry bulb temperatures ranging from 50° to 90°F (10° to 32°C). 1-1/2" (38mm) thick insulation is also available for relative humidity up to 90% and dry bulb temperatures ranging from 50° to 90°F (10° to 32°C).

**DOUBLE THICK INSULATION** – Double Thick (1-1/2") insulation provided on the evaporator if desired, for specific applications, such as glycol chilling.

**FLANGE KIT** – Provides contractor with the couplings best suited to tie into the chilled liquid piping; option can be selected separately for the evaporator and condenser.

Options include:

- HG 150 psig (10.3 barg) raised-face weldable flanges, for applications where field coupling has existing flanges. Flanges are field-welded by contractor. Also available in 300 psig (20.6 barg)
- HG 150 psig (10.3 barg) raised-face flanges with couplings, for applications where field coupling has existing flanges. Flanges are field-mounted by contractor. Also available in 300 psig (20.6 barg).

**NOZZLE OPTIONS/LIQUID OPTIONS** – Two- and three-pass nozzle arrangements available only in pairs shown and for all shell codes. Any pair of condenser nozzles may be used in combination with any pair of evaporator nozzles.

**THREE-PASS EVAPORATOR** – The standard evaporator is constructed with two chilled liquid passes through the evaporator. The three-pass option is recommended for

use in brine applications or where a greater liquid temperature difference is required without sacrificing efficiency.

**ONE- OR THREE-PASS CONDENSER** – The standard condenser is constructed with two liquid passes through the condenser. The one-pass option is recommended for use in series counter-flow applications; the three-pass option is recommended for use in heat pump applications where high temperature differences are required. The one- or three-pass options allow for customized cooling applications without the sacrifice of efficiency.

**NOZZLE OPTIONS/LIQUID OPTIONS** – Two- and three-pass nozzle arrangements available only in pairs shown and for all shell codes. Any pair of condenser nozzles may be used in combination with any pair of evaporator nozzles.

## CONTROLS OPTIONS

**BUILDING AUTOMATION SYSTEM INTERFACE (TEMPERATURE)** - Factory installed option to accept a 4 to 20 mA or a 0 to 10 VDC input to allow remote reset of the Leaving Chilled Liquid Temperature Setpoint. The setpoint can be positively offset upwards up to 40°F (22.2°C). This option is useful for ice storage or process applications or for periods where higher chilled liquid temperatures are adequate for low loads. Available alone or in combination with BAS Load Limit.

**BUILDING AUTOMATION SYSTEM INTERFACE (LOAD LIMIT)** - Factory installed option to accept a 4 to 20 mA or a 0 to 10 VDC input to allow remote reset of the Load Limit Setpoint. The setpoint can limit system demand from 30-100%. Available alone or in combination with BAS Temperature Reset.

**E-Link** – The E-Link Gateway provides full communication to Building Automation Systems, including BACnet (MS/TP), Modbus, LON and N2.

**THERMAL STORAGE** – Provides special control logic and modifications to produce leaving chilled brine temperatures below 40°F (4.4°C) primarily at times of low cooling load (night time). Option can be used to produce ice to supplement cooling and significantly decrease energy costs. The capability of the chiller is enhanced by using both ice and chilled liquid simultaneously during times of peak cooling needs.

## GENERAL OPTIONS

**FLOW SWITCH ACCESSORY** - Vapor proof SPDT, NEMA 3R switch, 150 psig (10.3 barg) DWP, -20°F to

250°F (-29°C to 121°C) with 1" NPT (IPS) connection for upright mounting in horizontal pipe (This flow switch or equivalent must be furnished with each unit for chilled liquid loop.). A condenser liquid flow switch is optional. **(Field mounted)**

**DIFFERENTIAL PRESSURE SWITCH** – This 3-45 psig (0.2-3 barg) range switch, with 1/4" NPTE pressure connections, is an alternative to the paddle-type flow switch. **(Field mounted)**

**REFRIGERANT ISOLATION VALVES** - For standard water chiller applications, optional factory-installed isolation valves in the compressor discharge line and refrigerant liquid line per circuit are available. This allows isolation and storage of the refrigerant charge in the chiller condenser during servicing, eliminating time-consuming transfers to remote storage vessels. Both valves in each of the independent refrigerant circuits are positive shut-off, assuring integrity of the storage system.

**DUAL PRESSURE RELIEF VALVE** – For ASME shells, two safety relief valves are mounted in parallel; one is always operational to assist in valve replacement during maintenance.

**PRESSURE VESSEL OPTIONS** – The evaporator and condenser can be provided with either ASME or PED pressure vessel codes certification.

**CIRCUIT BREAKER** – A unit-mounted circuit breaker with external lockable handle will be supplied to isolate the single point power voltage for servicing. The circuit

breaker is sized to provide motor branch circuit protection, short circuit protection and ground fault protection for the motor branch-circuit conductors, the motor control apparatus and the motors.

**SPECIAL REQUIREMENT DOCUMENTS** – There are two options to select from:

- Special Requirement Document Package (SRDP) includes Pressure Vessel Report, Unit Run Test Report, Production System Check Sheet and Final Unit Inspection Check Sheet.
- Factory Witness Run Test includes customer witness of chiller end-of-line run test in addition to the SRDP.
- Materials Package includes steel mill material reports for vessels in addition to the SRDP.

## VIBRATION ISOLATION

**ELASTOMERIC ISOLATION** – This option is recommended for normal installations. It provides very good performance in most applications for the least cost. Field mounted.

**1" SPRING ISOLATORS** – Spring and cage type isolators for mounting under the unit base rails are available to support unit. They are level adjustable. 1" nominal deflection may vary slightly by application. **(Field mounted)**

## SINGLE COMPRESSOR

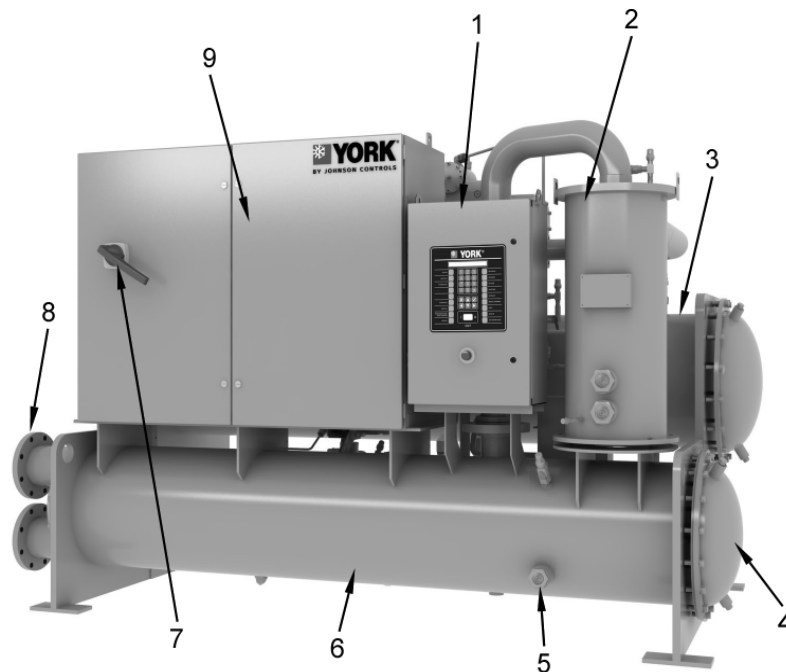

## DUAL COMPRESSOR

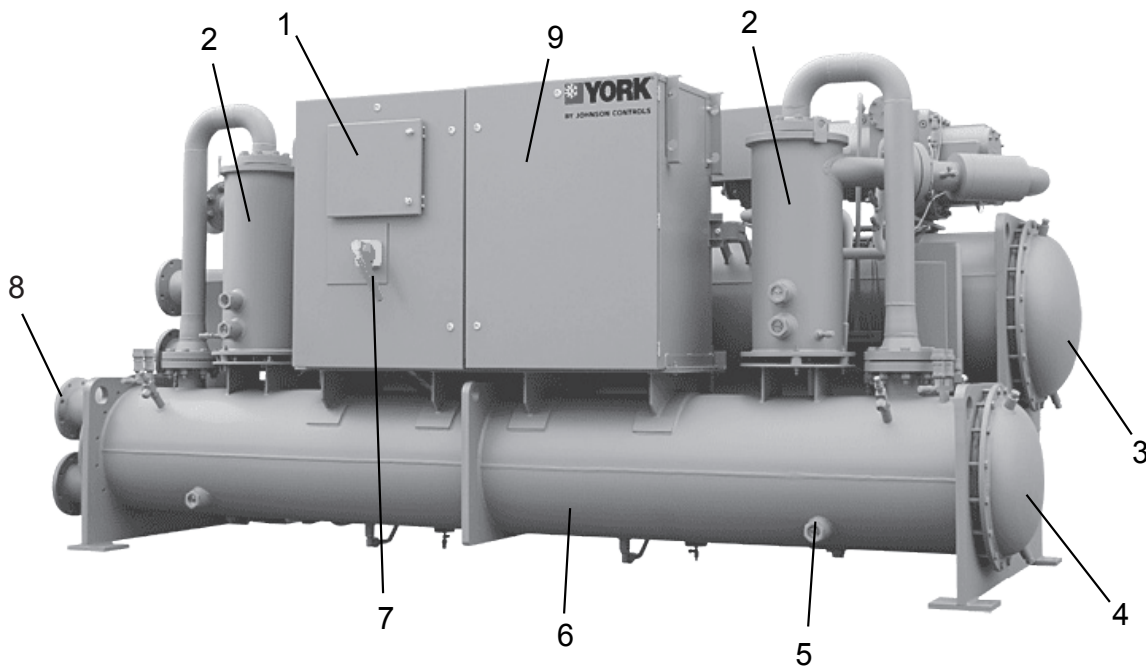

ITEM NUMBER	DESCRIPTION
1	Control Center
2	Oil Separator
3	Evaporator
4	Compact Waterbox
5	Sight Glass
6	Condenser
7	Circuit Breaker
8	Liquid Nozzles
9	Variable Speed Drive

# Unit Components - Back View

## SINGLE COMPRESSOR

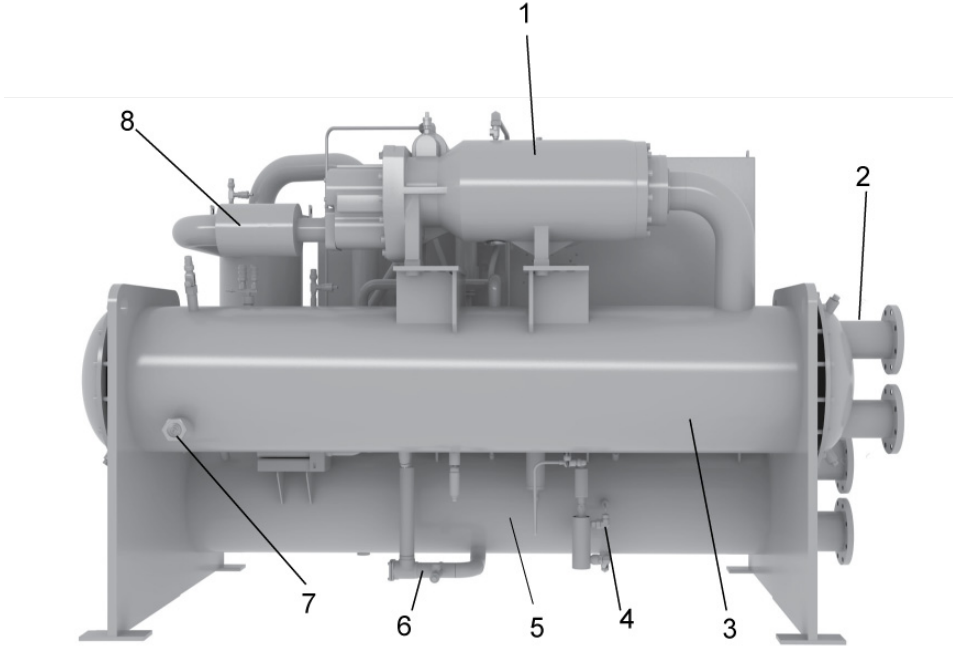

## DUAL COMPRESSOR

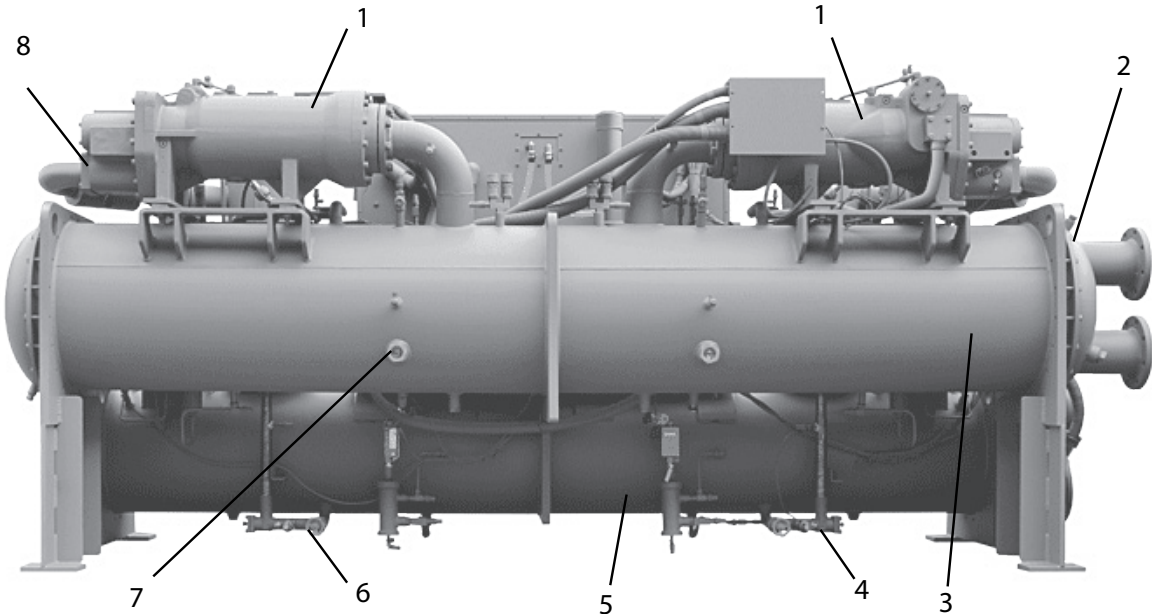

ITEM NUMBER	DESCRIPTION
1	Compressor
2	Compact Waterbox
3	Evaporator
4	Liquid Level Sensor
5	Condenser
6	Liquid Line
7	Sight Glass
8	Muffler

# Dimensions - Unit

TOP VIEW - SINGLE COMPRESSOR

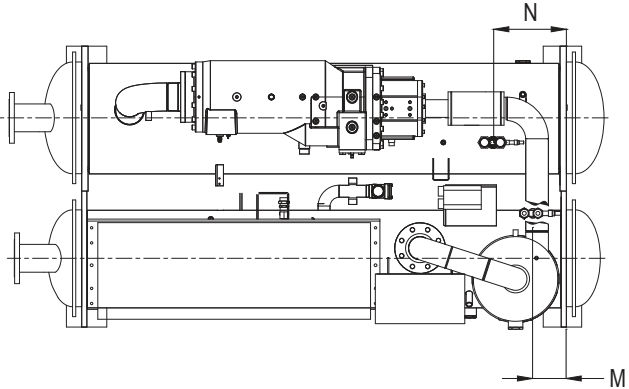

SIDE VIEW - BOTH

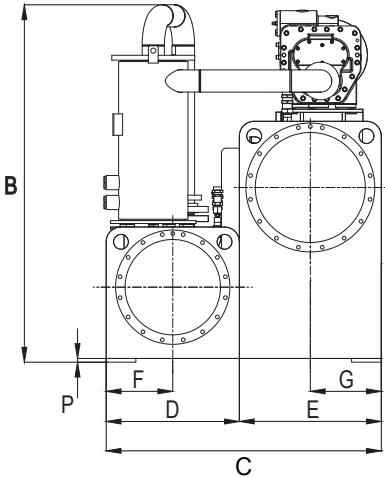

TOP VIEW - DUAL COMPRESSOR

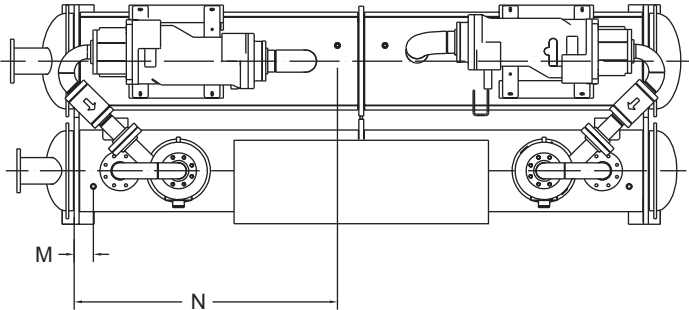

FRONT VIEW - SINGLE COMPRESSOR

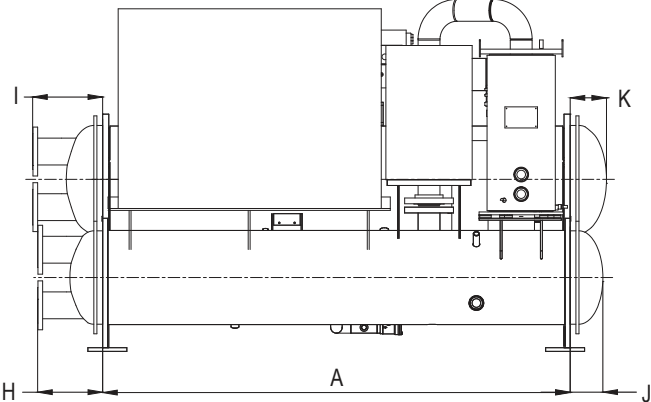

FRONT VIEW - DUAL COMPRESSOR

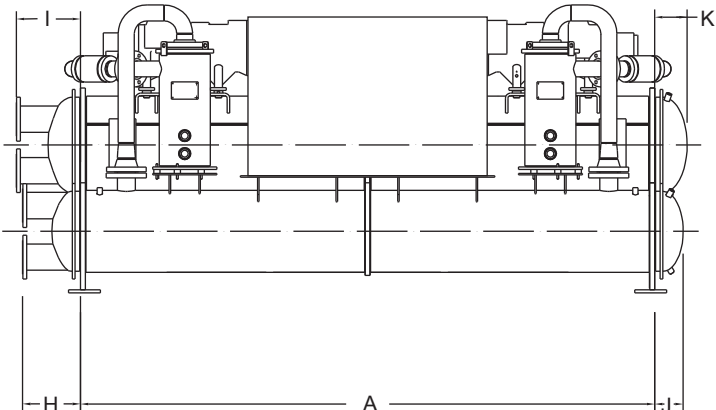

DIMENSIONS	EVAPORATOR AND CONDENSER SHELL CODES in (mm)				
	SINGLE 145/151			DUAL 136/145	
	B-B	C-C	D-D	M-M	N-N
A	8' (2438)	10' (3048)	12' (3658)	12' (3658)	14' (4268)
B	6'-11/16 (1846)	6'-11/16 (1846)	6'-11/16 (1846)	6'-3/4" (1844)	6'-3/4" (1844)
C	4'-7 5/8 (1413)	4'-7 5/8 (1413)	4'-7 5/8 (1413)	4'-7-5/16" (1405)	4'-7-5/16" (1405)
D	2'-2 15/16 (684)	2'-2 15/16 (684)	2'-2 15/16 (684)	2'-2-7/8" (683)	2'-2-7/8" (683)
E	2'-4 11/16 (729)	2'-4 11/16 (729)	2'-4 11/16 (729)	2'-4-3/8" (722)	2'-4-3/8" (722)
F	1'-1 15/32 (342)	1'-1 15/32 (342)	1'-1 15/32 (342)	1'-1-3/8" (342)	1'-1-3/8" (342)
G	1'-2 11/32 (365)	1'-2 11/32 (365)	1'-2 11/32 (365)	1'-2-3/16" (361)	1'-2-3/16" (361)
M	6 21/32 (169)	1'-6 21/32 (474)	2'-6 21/32 (779)	4-3/4" (123)	10-3/4" (275)
N	1'-2 17/32 (369)	2'-2 17/32 (674)	3'-2 17/32 (979)	5'-6" (1678)	6' (1830)

WATER BOX DIMENSIONS in (mm)											
DIM.	EVAPORATORS B & C & D			EVAPORATORS M, N		CONDENSER B & C & D			CONDENSERS M, N		
	1 PASS	2 PASS	3 PASS	2-PASS	3-PASS	1 PASS	2 PASS	3 PASS	1-PASS	2-PASS	3-PASS
H	—	—	—	—	—	1' 1 17/32 (344)	1' 1 17/32 (344)	1' 1 17/32 (344)	14-1/2" (369)	14-1/2" (369)	14-1/2" (369)
I	—	1' 2 3/8 (369)	1' 2 3/8 (369)	16-3/32" (409)	16-3/32" (409)	—	—	—	—	—	—
DIM.	REAR HEAD 2 PASS			REAR HEAD 2-PASS		REAR HEAD 2 PASS			REAR HEAD 2-PASS		
J	—			—		6 29/32 (176)			5-3/4" (146)		
K	7 21/32 (195)			6-5/32" (156)		—			—		

ADDITIONAL OPERATING HEIGHT in (mm)	
CLEARANCE TO FLOOR	P
TYPE OF CHILLER MOUNTING	
NEOPRENE PAD ISOLATORS	1-3/4" (44.5)
SPRING ISOLATORS 1" DEFLECTION	1" (25.4)
DIRECT MOUNT	3/4" (19.1)

**NOTES:**

- All dimensions are approximate. Certified dimensions are available on request.
- Evaporator and condenser water nozzles can be located on either end of unit.
- Standard 150 PSI (10.3 barg) design pressure boxes shown.
- To determine overall height, add dimension "P" for the appropriate isolator type.
- Front of unit is defined as side of chiller where control center is mounted.
- In order to achieve rated performance, condenser liquid must enter the water box through the bottom connection for proper operation of the sub-cooler.
- Connected piping should allow for the removal of the compact water boxes for tube access and cleaning.

## EVAPORATORS – COMPACT WATER BOXES (STANDARD)

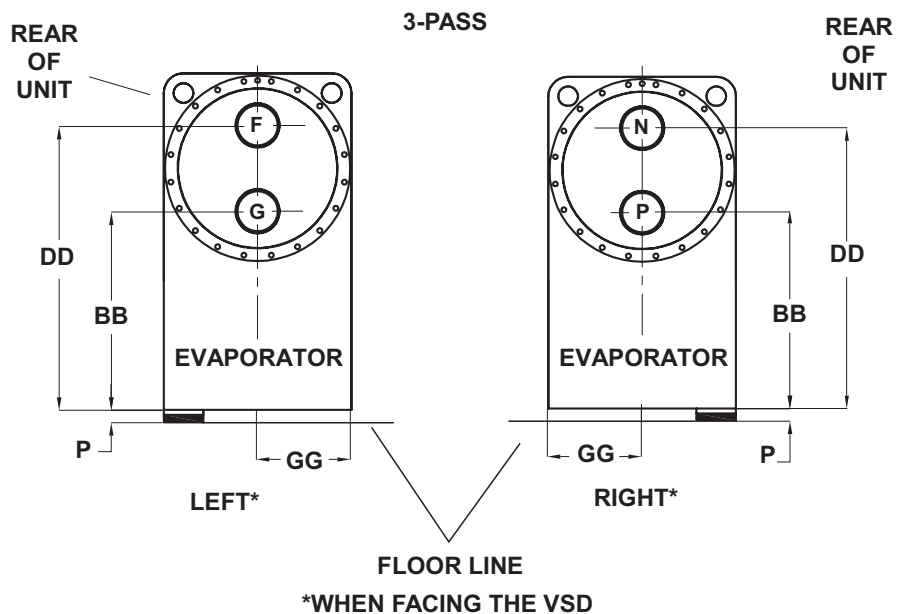
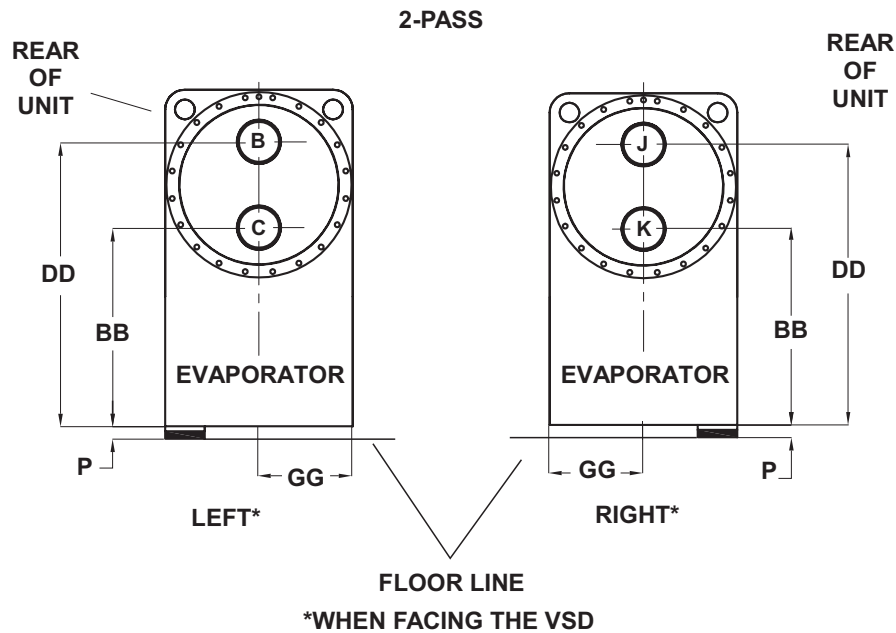

**NOTES:**

1. All dimensions are approximate. Certified dimensions are available on request.
2. Standard water nozzles are furnished with HG welded flanges. Factory-installed class 150 (HG/T20615, round slip-on forged carbon steel with 2mm raised face) water flanged nozzles are optional. Companion flanges, nuts, bolts, and gaskets are not furnished.
3. Evaporator and condenser water nozzles can be located on either end of the unit.
4. Standard 150 PSI (10.3 barg) design pressure boxes shown.
5. In order to achieve the rated performance, condenser liquid must enter the water box through the bottom connection for proper operation of the sub-cooler.
6. Connected piping should allow for the removal of the compact water boxes for tube access and cleaning.

2-PASS		
NOZZLE ARRANGEMENTS		
NUMBER OF PASSES	EVAPORATOR	
	IN	OUT
2	C	B
	K	J

NOTE: Liquid must enter through lower connection to achieve rated performance.

3-PASS		
NOZZLE ARRANGEMENTS		
NUMBER OF PASSES	EVAPORATOR	
	IN	OUT
3	G	N
	P	F

NOTE: Liquid must enter through lower connection to achieve rated performance.

ADDITIONAL OPERATING HEIGHT in (mm)	
CLEARANCE TO FLOOR	P
TYPE OF CHILLER MOUNTING	
NEOPRENE PAD ISOLATORS	1-3/4" (44.5)
SPRING ISOLATORS 1" DEFLECTION	1" (25.4)
DIRECT MOUNT	3/4" (19.1)

EVAPORATOR SHELL CODE	NOZZLE PIPE SIZE			EVAPORATOR NOZZLE DIMENSIONS ft - in (mm)					
	NO.OF PASSES			2-PASS			3-PASS		
	1	2	3	BB	DD	GG	BB	DD	GG
B,C,D	8"	5"	5"	2'-4-27/32" (733)	3'-4-9/32" (1023)	1'-2-11/32" (365)	2'-4-27/32" (-733)	3'-4-9/32" (1023)	1'-2-11/32" (365)
M, N	-	6"	6"	2'-6" (763)	3'-7" (1093)	1'-2-7/32" (361)	2'-6" (763)	3'-7" (1093)	1'-2-7/32" (361)

# Dimensions - Condensers

## CONDENSERS – COMPACT WATER BOXES (STANDARD)

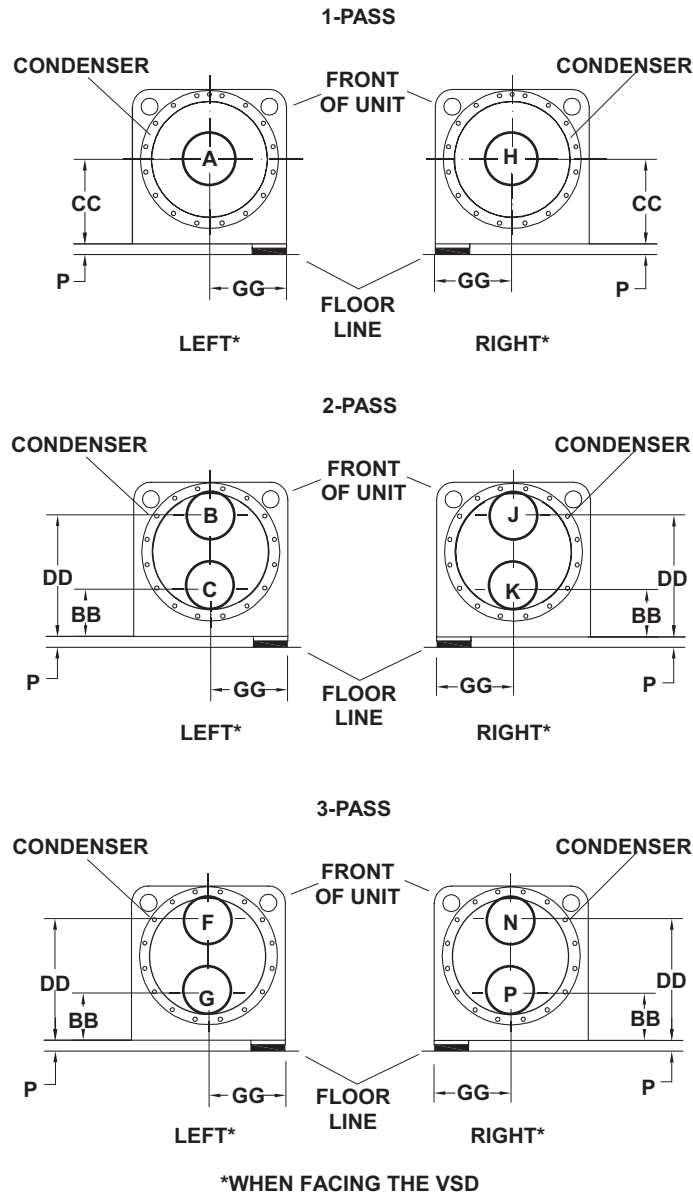

### NOTES:

1. All dimensions are approximate. Certified dimensions are available on request.
2. Standard water nozzles are furnished with HG welded flanges. Factory-installed class 150 (HG/T20615, round slip-on forged carbon steel with 2mm raised face) water flanged nozzles are optional. Companion flanges, nuts, bolts, and gaskets are not furnished.
3. Evaporator and condenser water nozzles can be located on either end of the unit.
4. Standard 150 PSI (10.3 barg) design pressure boxes shown.
5. In order to achieve the rated performance, condenser liquid must enter the water box through the bottom connection for proper operation of the sub-cooler.
6. Connected piping should allow for the removal of the compact water boxes for tube access and cleaning.

1-PASS		
NOZZLE ARRANGEMENTS		
NUMBER OF PASSES	CONDENSER	
	IN	OUT
1	A	H
	H	A

2-PASS		
NOZZLE ARRANGEMENTS		
NUMBER OF PASSES	CONDENSER	
	IN	OUT
2	C	B
	K	J

NOTE: Liquid must enter through lower connection to achieve rated performance.

3-PASS		
NOZZLE ARRANGEMENTS		
NUMBER OF PASSES	CONDENSER	
	IN	OUT
3	G	N
	P	F

NOTE: Liquid must enter through lower connection to achieve rated performance.

ADDITIONAL OPERATING HEIGHT in (mm)	
CLEARANCE TO FLOOR	P
TYPE OF CHILLER MOUNTING	
NEOPRENE PAD ISOLATORS	1-3/4" (44.5)
SPRING ISOLATORS 1" DEFLECTION	1" (25.4)
DIRECT MOUNT	3/4" (19.1)

CONDENSER SHELL CODE	NOZZLE PIPE SIZE			CONDENSER							
				NOZZLE DIMENSIONS ft - in (mm)							
	NO. OF PASSES			1-PASS		2-PASS			3-PASS		
1	2	3	CC	GG	BB	DD	GG	BB	DD	GG	
B,C,D	8"	5"	5"	1'-2-13/32" (366)	1'-1-15/32" (366)	8-11/16" (366)	1'-8-1/8" (366)	1'-1-11/32" (366)	8-11/16" (366)	1'-8-1/8" (366)	1'-1-11/32" (366)
M, N	8"	6"	6"	1'-2-3/4" (375)	1'-1-7/16" (342)	8-3/32" (210)	1'-9-1/4" (540)	1'-1-7/16" (342)	8-3/32" (210)	1'-9-1/4" (540)	1'-1-7/16" (342)

# Dimension – Floor Layout - Neoprene Pad

## SINGLE COMPRESSOR UNIT

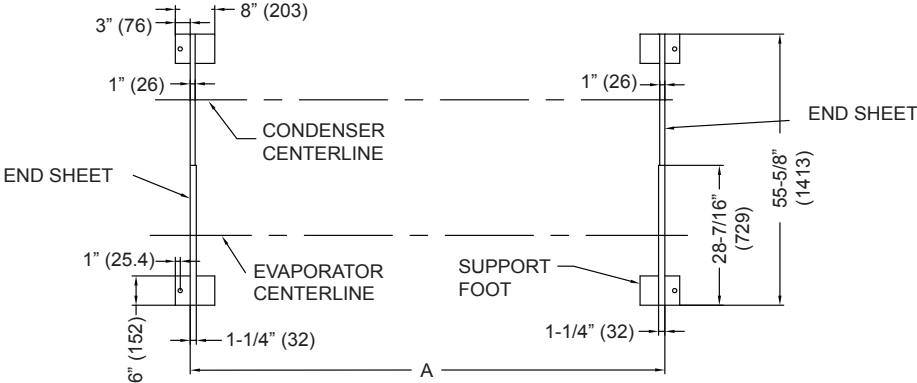

ISOLATOR DETAIL (N.T.S.)

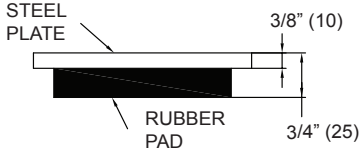
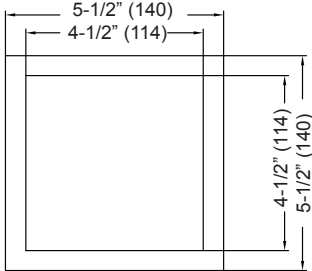

- NOTES:**
1. Dimensions are typical for all four pads.
  2. Dimensions are in inches (MM).
  3. Isolator to be centered under support foot.

DIMENSIONS	HEAT EXCHANGER SHELL CODES ft (mm)		
	SINGLE 145/151		
	8'	10'	12'
A	8' (2438)	10' (3048)	12' (3658)



# Dimension – Floor Layout - Spring Isolator

## SINGLE COMPRESSOR UNIT

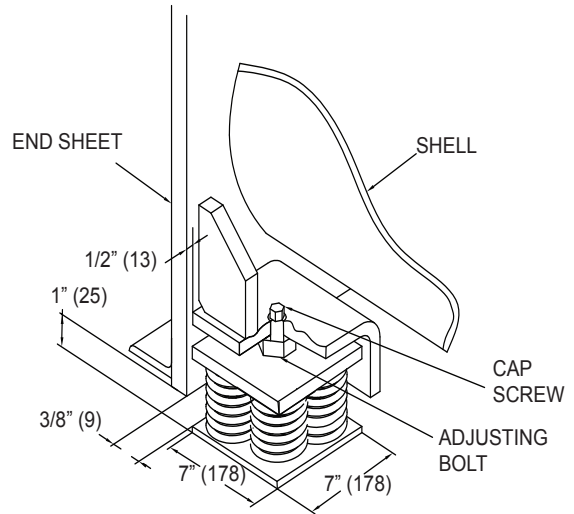
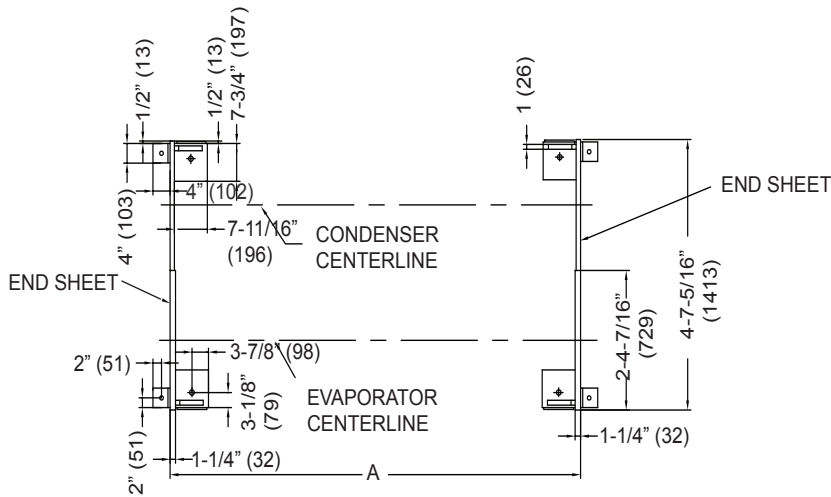

**NOTES:**

1. Dimensions are typical for all four pads.
2. Dimensions are in inches (MM).
3. Isolator to be centered under support foot.

DIMENSIONS	HEAT EXCHANGER SHELL CODES(mm)		
	SINGLE 145/151		
	8'	10'	12'
A	8' (2438)	10' (3048)	12' (3658)

## DUAL COMPRESSOR UNIT

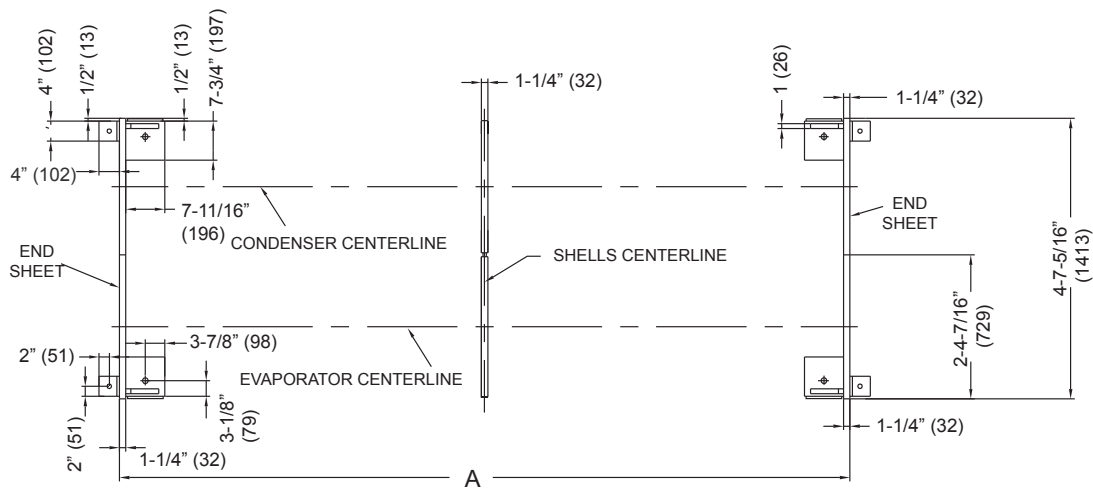

**NOTES:**

1. Dimensions are typical for all eight pads.
2. Dimensions are in inches (MM).
3. Isolator to be centered under support foot.

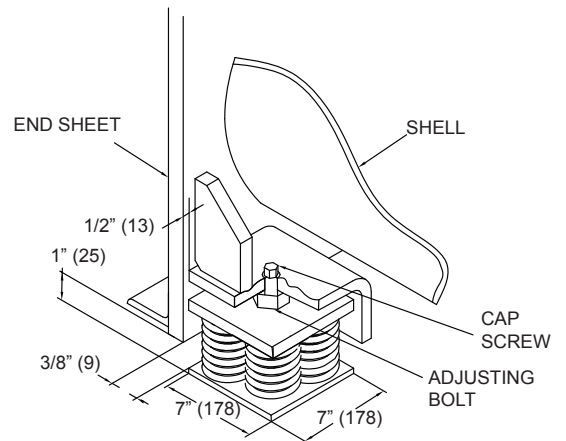

DIMENSIONS	HEAT EXCHANGER SHELL CODES(mm)		
	DUAL 136/145		
	8'	10'	12'
A	8' (2438)	10' (3048)	12' (3658)

# Weights

APPROXIMATE UNIT WEIGHT										
COMPR.	SHELLS	SHIPPING WEIGHT RANGE MIN - MAX		OPERATING WEIGHT RANGE MIN - MAX		REFRIGERANT CHARGE RANGE MIN - MAX		LOADING PER ISOLATOR MIN - MAX		
		LBS	KG	LBS	KG	LBS	KG	LBS	KG	
SINGLE	FX	B-B	7694-8329	3490-3778	8254-8995	3744-4080	276-298	125-135	2064-2249	936-1020
		C-C	8263-8519	3748-3864	8915-9306	4044-4221	331-353	150-160	2229-2326	1011-1055
		D-D	8922-9228	4047-4186	9667-10135	4385-4597	386-408	175-185	2416-2533	1096-1149
	GX	B-B	7981-8616	3620-3908	8541-9281	3874-4210	298-320	135-145	2134-2321	968-1053
		C-C	8549-8805	3878-3994	9202-9592	4174-4351	353-375	160-170	2299-2399	1043-1088
		D-D	9209-9515	4177-4316	9954-10421	4515-4727	408-430	185-195	2489-2606	1129-1182
DUAL	EE	M-M	10,541-11,693	4,782-5,304	11,497-12,950	5,215-5,874	573-595	260-270	2,875-3,279	1,304-1,469
		N-N	12,180-12,450	5,525-5,647	13,251-13,880	6,011-6,296	617-639	280-290	3,314-3,370	1,503-1,574
	FE	M-M	10,610-11,762	4,813-5,335	11,566-13,019	5,246-5,905	584-606	265-275	2,892-3,254	1,312-1,476
		N-N	12,248-12,519	5,556-5,678	13,319-13,948	6,042-6,327	628-650	285-295	3,329-3,428	1,510-1,582
	FF	M-M	10,678-11,830	4,844-5,366	11,634-13,087	5,277-5,396	595-617	270-280	2,908-3,272	1,319-1,484
		N-N	12,317-12,587	5,587-5,709	13,388-14,017	6,073-6,358	639-661	290-300	3,347-3,503	1,518-1,589

NOTE: Weights shown for base unit; selected options and tube count variations may add weights and/or refrigerant charge quantity to unit. Contact your nearest Johnson Controls Sales Office for weight data.

## Electrical Data

LUG SIZES						
FIELD WIRING LUGS			SINGLE CIRCUIT			
			CIRCUIT BREAKER			
VSD FRAME	INPUT VOLTS	INPUT FREQ	LUG/ PHASE	WIRES PER LUG	LUG WIRE RANGE UL & CE	LUG WIRE RANGE GB
A	380	50	1	2	#2/0 AWG-500KCMIL	#2/0 AWG-500KCMIL
	400	50	1	2	#2/0 AWG-500KCMIL	#2/0 AWG-500KCMIL
	415	50	1	2	#2/0 AWG-500KCMIL	#2/0 AWG-500KCMIL
B	380	50	1	2	#2/0 AWG-500KCMIL	#2/0 AWG-500KCMIL
	400	50	1	2	#2/0 AWG-500KCMIL	#2/0 AWG-500KCMIL
	415	50	1	2	#2/0 AWG-500KCMIL	#2/0 AWG-500KCMIL
C	380	50	1	2	#2/0 AWG-500KCMIL	#2/0 AWG-500KCMIL
	400	50	1	2	#2/0 AWG-500KCMIL	#2/0 AWG-500KCMIL
	415	50	1	2	#2/0 AWG-500KCMIL	#2/0 AWG-500KCMIL
D	380	50	1	2	#3/0 AWG-500KCMIL	#2/0 AWG-500KCMIL
	400	50	1	2	#3/0 AWG-500KCMIL	#2/0 AWG-500KCMIL
	415	50	1	2	#3/0 AWG-500KCMIL	#2/0 AWG-500KCMIL

Notes:

1. The 50Hz and 60Hz drives will use the same circuit breaker.
2. The D frame size uses the Eaton L series circuit breaker which comes with the 400kcmil~500kcmil lugs. We put another set of 3/0 AWG -350kcmil lugs in the VSD.

**Electrical Data - continued**

FIELD WIRING LUGS			TERMINAL BLOCK			CIRCUIT BREAKER			NON-FUSED DISCONNECT SWITCH		
VSD FRAME	INPUT VOLTS	INPUT FREQ	LUG/ PHASE	WIRES PER LUG	LUG WIRE RANGE	LUG/ PHASE	WIRES PER LUG	LUG WIRE RANGE	LUG/ PHASE	WIRES PER LUG	LUG WIRE RANGE
A	200	60	N/A	N/A	N/A	N/A	N/A	N/A	N/A	N/A	N/A
	230	60	N/A	N/A	N/A	N/A	N/A	N/A	N/A	N/A	N/A
	380	60	1	2	#2 AWG - 600kcmil	1	2	#2/0AWG-400KCMIL	1	2	#2 AWG - 600kcmil
	380	50	1	2	#2 AWG - 600kcmil	1	2	#2/0AWG-400KCMIL	1	2	#2 AWG - 600kcmil
	400	50	1	2	#2 AWG - 600kcmil	1	2	#2/0AWG-400KCMIL	1	2	#2 AWG - 600kcmil
	415	50	1	2	#2 AWG - 600kcmil	1	2	#2/0AWG-400KCMIL	1	2	#2 AWG - 600kcmil
	460	60	1	2	#2 AWG - 600kcmil	1	2	#2/0AWG-500KCMIL	1	2	#2 AWG - 600kcmil
	575	60	N/A	N/A	N/A	N/A	N/A	N/A	N/A	N/A	N/A
B	200	60	1	4	#2 AWG - 600kcmil	1	4	#4/0AWG-500KCMIL	N/A	N/A	N/A
	230	60	1	4	#2 AWG - 600kcmil	1	4	#4/0AWG-500KCMIL	N/A	N/A	N/A
	380	60	1	2	#2 AWG - 600kcmil	1	2	#1/0AWG-500KCMIL	1	2	#2 AWG - 600kcmil
	380	50	1	2	#2 AWG - 600kcmil	1	2	#1/0AWG-500KCMIL	1	2	#2 AWG - 600kcmil
	400	50	1	2	#2 AWG - 600kcmil	1	2	#1/0AWG-500KCMIL	1	2	#2 AWG - 600kcmil
	415	50	1	2	#2 AWG - 600kcmil	1	2	#1/0AWG-500KCMIL	1	2	#2 AWG - 600kcmil
	460	60	1	2	#2 AWG - 600kcmil	1	2	#1/0AWG-500KCMIL	1	2	#2 AWG - 600kcmil
	575	60	1	2	#2 AWG - 600kcmil	1	2	#1/0AWG-500KCMIL	1	2	#2 AWG - 600kcmil
C	200	60	N/A	N/A	N/A	N/A	N/A	N/A	N/A	N/A	N/A
	230	60	N/A	N/A	N/A	N/A	N/A	N/A	N/A	N/A	N/A
	380	60	1	3	#2 AWG - 600kcmil	1	3	#3/0AWG-400KCMIL	2	2	#2 AWG - 600kcmil
	380	50	1	3	#2 AWG - 600kcmil	1	3	#3/0AWG-400KCMIL	2	2	#2 AWG - 600kcmil
	400	50	1	3	#2 AWG - 600kcmil	1	3	#3/0AWG-400KCMIL	2	2	#2 AWG - 600kcmil
	415	50	1	3	#2 AWG - 600kcmil	1	3	#3/0AWG-400KCMIL	2	2	#2 AWG - 600kcmil
	460	60	N/A	N/A	N/A	N/A	N/A	N/A	N/A	N/A	N/A
	575	60	N/A	N/A	N/A	N/A	N/A	N/A	N/A	N/A	N/A
D	200	60	N/A	N/A	N/A	N/A	N/A	N/A	N/A	N/A	N/A
	230	60	N/A	N/A	N/A	N/A	N/A	N/A	N/A	N/A	N/A
	380	60	1	3	#2 AWG - 600kcmil	1	4	#4/0AWG-500KCMIL	2	2	#2 AWG - 600kcmil
	380	50	1	3	#2 AWG - 600kcmil	1	4	#4/0AWG-500KCMIL	2	2	#2 AWG - 600kcmil
	400	50	1	3	#2 AWG - 600kcmil	1	4	#4/0AWG-500KCMIL	2	2	#2 AWG - 600kcmil
	415	50	1	3	#2 AWG - 600kcmil	1	4	#4/0AWG-500KCMIL	2	2	#2 AWG - 600kcmil
	460	60	1	3	#2 AWG - 600kcmil	1	3	#3/0AWG-400KCMIL	2	2	#2 AWG - 600kcmil
	575	60	1	2	#2 AWG - 600kcmil	1	2	#1/0AWG-500KCMIL	2	2	#2 AWG - 600kcmil





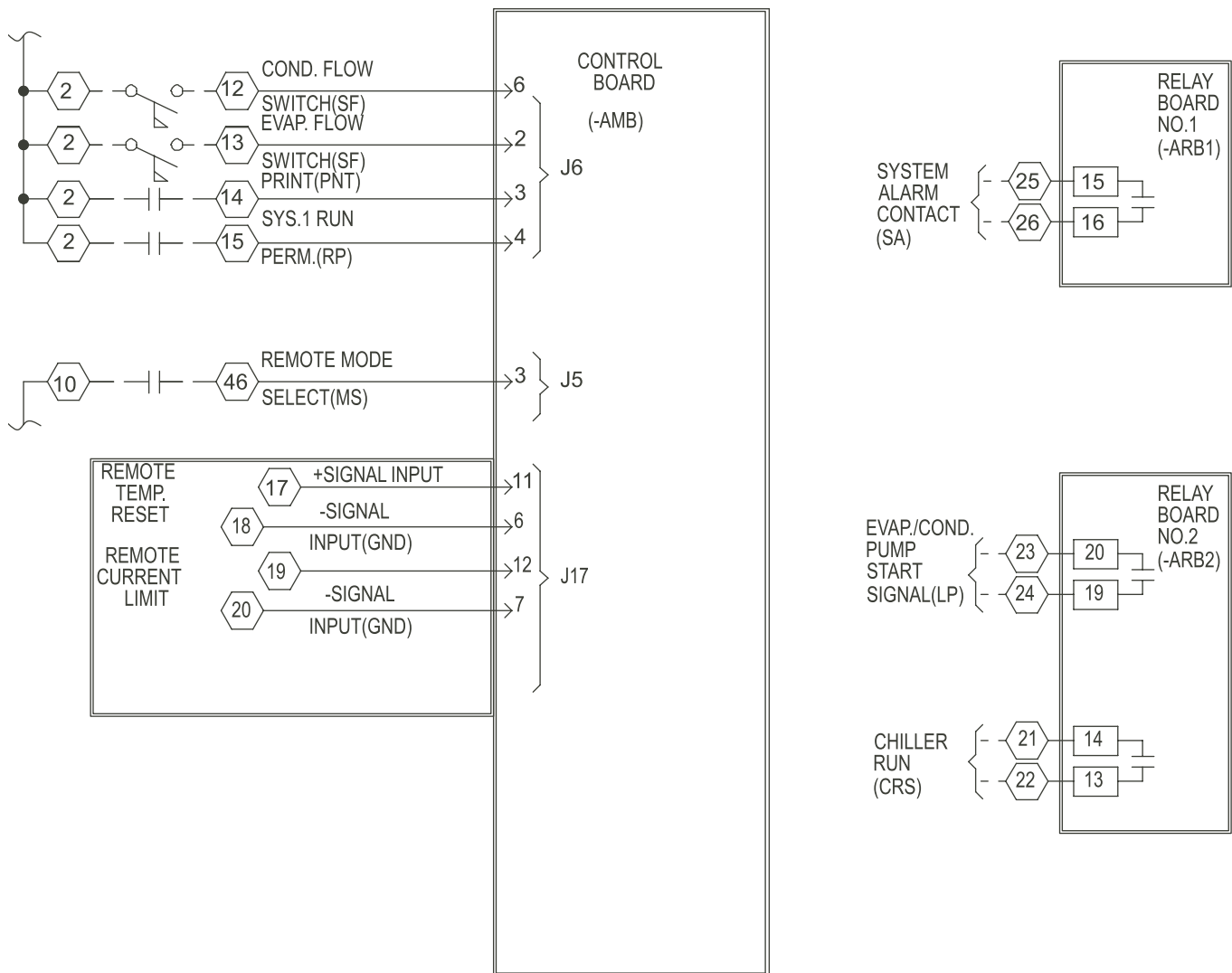

**VOLTAGE CODE**

-17 = 208-3-60  
-28 = 230-3-60  
-40 = 380-3-60  
-46 = 460-3-60  
-65 = 380-3-50  
-50 = 400-3-50  
-68 = 415-3-50  
-58 = 575-3-60

## SINGLE COMPRESSOR UNITS





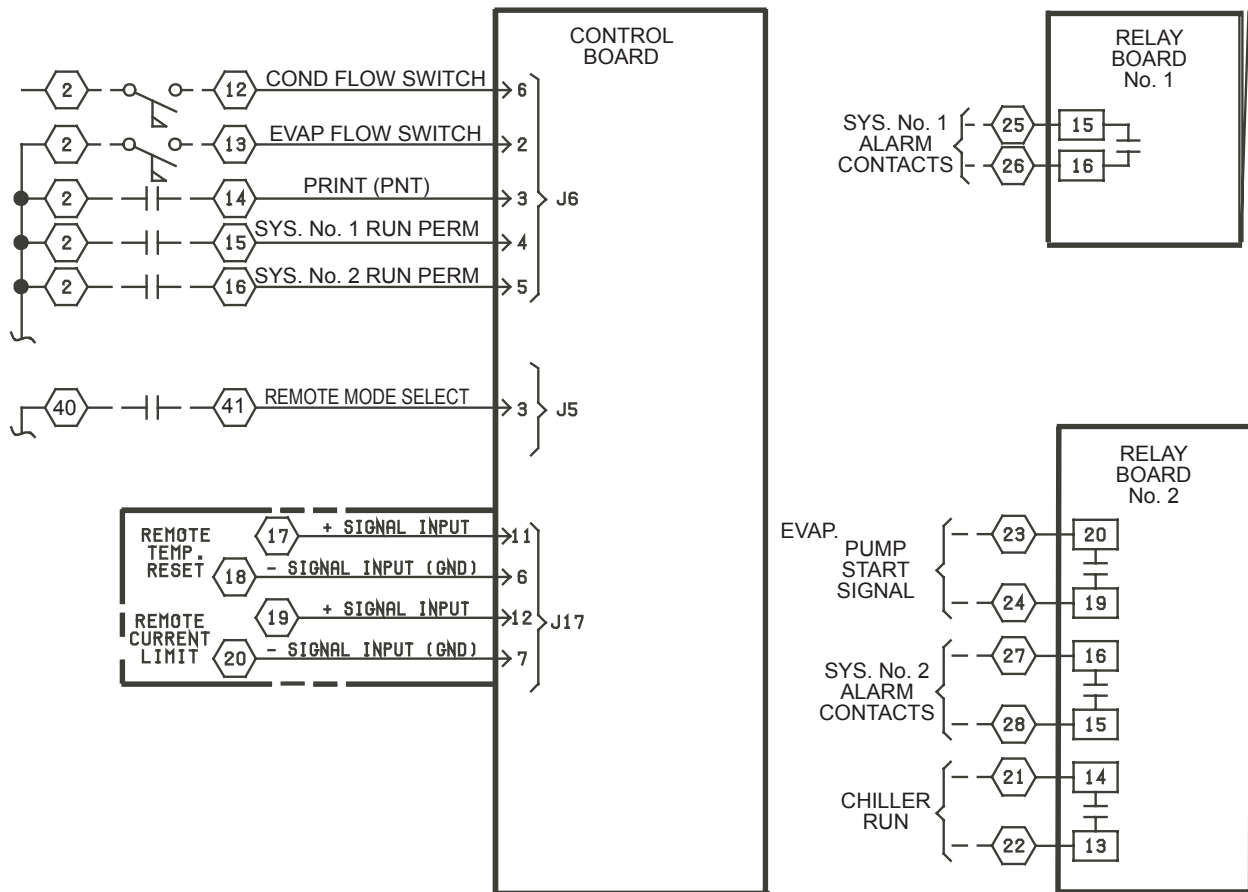

### LEGEND

-  TERMINAL BLOCK FOR CUSTOMER CONNECTIONS
-  TERMINAL BLOCK FOR YORK CONNECTIONS
-  WIRING AND COMPONENTS BY YORK
-  OPTIONAL EQUIPMENT
-  WIRING AND/OR COMPONENTS BY OTHERS
-  WIRING

## DUAL COMPRESSOR UNITS



- LEGEND**
-  TERMINAL BLOCK FOR CUSTOMER CONNECTIONS
  -  TERMINAL BLOCK FOR YORK CONNECTIONS
  -  WIRING AND COMPONENTS BY YORK
  -  OPTIONAL EQUIPMENT
  -  WIRING AND/OR COMPONENTS BY OTHERS

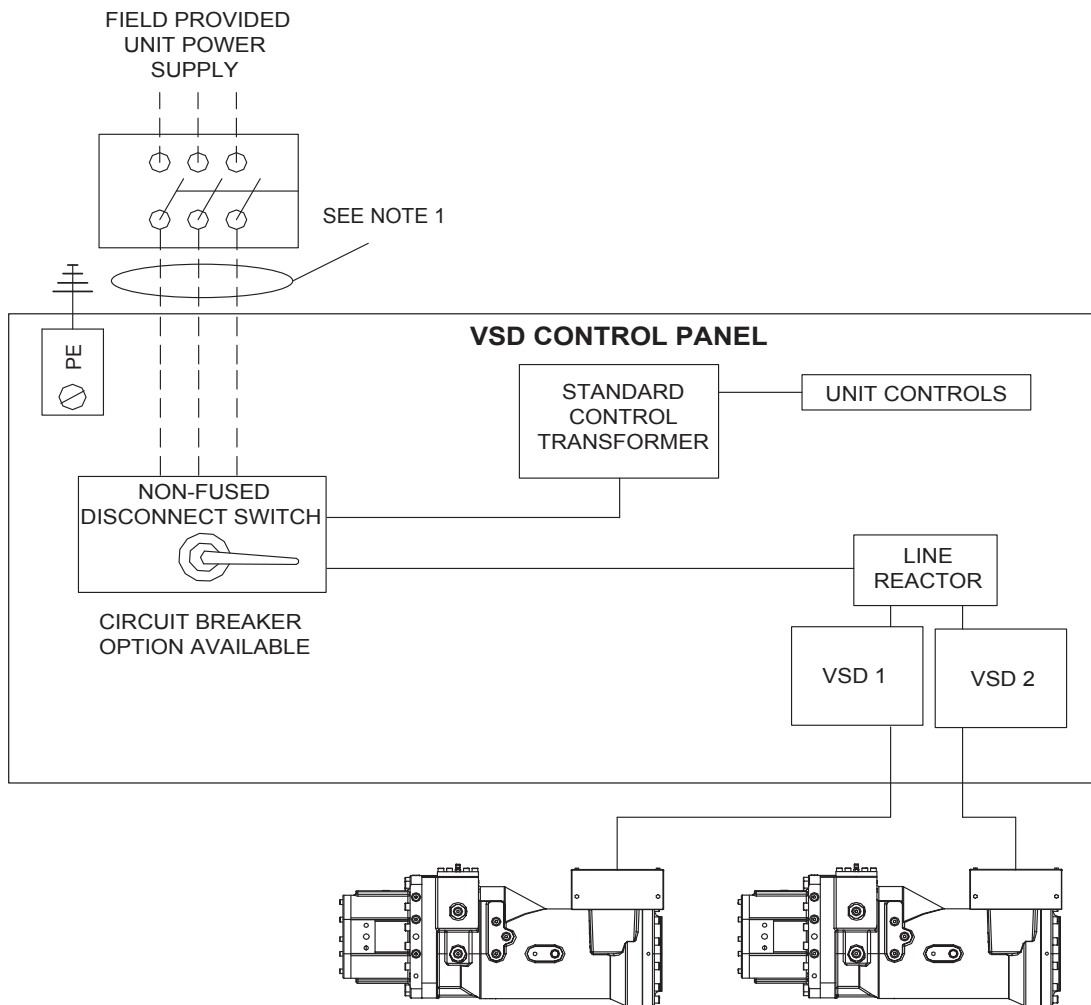

**NOTES:**

1. ----- Dashed Line = Field Provided Wiring
2. The transformer is located outside of the control panel.

Compressor #2 and VSD 2 only available on two compressor models.

## Application Data

The following discussion is a user's guide in the application and installation of YVWA chillers to ensure the reliable, trouble-free life for which this equipment was designed. While this guide is directed towards normal, liquid-chilling applications, a Johnson Controls sales engineer can provide complete recommendations on other types of applications.

### LOCATION

YVWA chillers are virtually vibration free and may generally be located at any level in a building where the construction will support the total system operating weight. The unit site must be a floor, mounting pad or foundation which is level within 1/4" (6.4 mm) and capable of supporting the operating weight of the unit.

Sufficient clearance to permit normal service and maintenance work should be provided all around and above the unit. Additional space should be provided at one end of the unit to permit cleaning of evaporator and condenser tubes as required. A doorway or other properly located opening may be used.

The chiller should be installed in an indoor location where temperatures range from 40°F to 110°F (4.4°C to 43.3°C). The dew point temperature in the equipment room must be below the entering condenser liquid temperature to prevent condensing liquid vapor inside of the low voltage VSD. Applications using cooling sources other than evaporative or closed loop air exchange methods need to request a factory-supplied temperature control valve to prevent condensation inside the VSD. Other areas susceptible to liquid vapor condensate are outside of the condenser shell and condenser water boxes. Example applications include cooling condenser liquid using chilled liquid, wells, river or other low temperature fluids. For outdoor applications, please contact your nearest Johnson Controls Sales Office.

### LIQUID CIRCUITS

**Flow Rate** – Variable flow in the condenser is not recommended, as it generally raises the energy consumption of the system by keeping the condenser pressure high in the chiller. Additionally, the rate of fouling in the condenser will increase at lower liquid velocities associated with variable flow, raising system maintenance costs. Ref. Table 1 & 2 (pgs. 28 and 29) for flow limits at design conditions.

There is increasing interest to use variable primary flow (VPF) systems in large chilled liquid plants. VPF systems can offer lower installation and operating costs in many cases, but do require more sophisticated control and flow monitoring.

YVWA chillers will operate successfully in VPF systems. With a minimum allowable evaporator tube velocity of 1.5 ft/sec. (0.5 m/s) for standard tubes at part-load rating conditions, YVWA chillers will accommodate the wide variation in flow required by many chilled liquid VPF applications.

The chillers can tolerate a 50% flow rate change in one minute that is typically associated with the staging on or off of an additional chiller; however a lower flow rate change is normally used for better system stability and set point control. Proper sequencing via the building automation system will make this a very smooth transition.

**Temperature Ranges** – For normal liquid chilling duty, leaving chilled liquid temperatures may be selected between 38°F and 60°F (3.3°C and 15.6°C).

**Condenser Water** – Units are equipped with a unit mounted and factory wired flow detection sensors. The chiller is engineered for maximum efficiency at both design and part-load operation by taking advantage of the colder cooling tower water temperatures which naturally occur during the winter months. Appreciable power savings are realized from these reduced heads.

The minimum entering condenser water temperature for other full and part-load conditions is provided by the following equation:

#### Standard Head Compressor

$$\text{Min ECWT} = 0.75 \cdot \text{LCHWT} + 33 - \text{full load condenser water } \Delta T \cdot 0.95\% \text{ Load (temperatures in } ^\circ\text{F)}$$

$$\text{Min ECWT} = 0.75 \cdot \text{LCHWT} + 13.9 - \text{full load condenser water } \Delta T \cdot 0.95\% \text{ Load (temperatures in } ^\circ\text{C)}$$

#### High Head Compressor

$$\text{Min ECWT} = 0.72 \cdot \text{LCHWT} + 39 - \text{full load condenser water } \Delta T \cdot 0.98\% \text{ Load (temperatures in } ^\circ\text{F)}$$

$$\text{Min ECWT} = 0.72 \cdot \text{LCHWT} + 16.7 - \text{full load condenser water } \Delta T \cdot 0.98\% \text{ Load (temperatures in } ^\circ\text{C)}$$

**Liquid Quality** – The practical and economical application of liquid chillers requires that the quality of the liquid supply for the condenser and evaporator be analyzed by a liquid treatment specialist. Liquid quality may affect the performance of any chiller through corrosion, deposition of heat-resistant scale, sedimentation or organic growth. These will degrade chiller performance and increase operating and maintenance costs. Normally, performance may be maintained by corrective liquid treatment and periodic cleaning of tubes. If liquid conditions exist which cannot be corrected by proper liquid treatment, it may be necessary to provide a larger allowance for fouling, and/or to specify special materials of construction.

## Application Data - continued

**General Piping** – All chilled liquid and condenser liquid piping should be designed and installed in accordance with accepted piping practice. Chilled liquid and condenser liquid pumps should be located to discharge through the chiller to assure positive pressure and flow through the unit. Piping should include offsets to provide flexibility and should be arranged to prevent drainage of liquid from the evaporator and condenser when the pumps are shut off. Piping should be adequately supported and braced independently of the chiller to avoid the imposition of strain on chiller components. Hangers must allow for alignment of the pipe. Isolators in the piping and in the hangers are highly desirable in achieving sound and vibration control.

**Convenience Considerations** – To facilitate the performance of routine maintenance work, some or all of the following steps may be taken by the purchaser. Evaporator and condenser water boxes are equipped with plugged vent and drain connections. If desired, vent and drain valves may be installed with or without piping to an open drain. Pressure gauges with stop-cocks and stop-valves may be installed in the inlets and outlets of the condenser and chilled liquid line as close as possible to the chiller. An overhead monorail or beam may be used to facilitate servicing.

**Connections** – The standard chiller is designed for 150 psig (10.3 barg) design working pressure in both the chilled liquid and condenser liquid circuits. The connections (liquid nozzles) to these circuits are furnished with HG raised-face welded flanges grooves for grooved and shouldered joints. Piping should be arranged for ease of disassembly at the unit for tube cleaning. All liquid piping should be thoroughly cleaned of all dirt and debris before final connections are made to the chiller.

**Chilled Liquid** – A liquid strainer of maximum 1/8" (3.2 mm) perforated holes must be field-installed in the chilled liquid inlet line as close as possible to the chiller. If located close enough to the chiller, the chilled liquid pump may be protected by the same strainer. The strainer is important to protect the chiller from debris or objects which could block flow through individual heat exchanger tubes. A reduction in flow through tubes could seriously impair the chiller performance or even result in tube freeze-up. A paddle -type flow switch is field installed in the evaporator nozzle and connected to the panel, which assures adequate chilled liquid flow during operation.

**Condenser Liquid** – The chiller is engineered for maximum efficiency at both design and part-load operation by taking advantage of the colder cooling tower liquid temperatures which naturally occur during the winter months. Appreciable power savings are realized from these reduced heads.

At initial startup, entering condensing liquid temperature may be as much as 25°F (13.9°C) colder than the standby chilled liquid temperature.

### MULTIPLE UNITS

**Selection** – Many applications require multiple units to meet the total capacity requirements as well as to provide flexibility and some degree of protection against equipment shutdown. There are several common unit arrangements for this type of application. The YVWA chiller has been designed to be readily adapted to the requirements of these various arrangements.

**Parallel Arrangement** (Refer to Figure 2) – Chillers may be applied in multiples with chilled and condenser liquid circuits connected in parallel between the units. Figure 1 represents a parallel arrangement with two chillers. Parallel chiller arrangements may consist of equally or unequally sized units. When multiple units are in operation, they will load and unload at equal percentages of design full load for the chiller.

Depending on the number of units and operating characteristics of the units, loading and unloading schemes should be designed to optimize the overall efficiency of the chiller plant. It is recommended to use an evaporator bypass piping arrangement to bypass fluid around evaporator of any unit which has cycled off at reduced load conditions. It is also recommended to alternate the chiller cycling order to equalize chiller starts and run hours.

**Series Arrangement** (Refer to Figure 3) – Chillers may be applied in pairs with chilled liquid circuits connected in series and condenser liquid circuits connected in parallel. All of the chilled liquid flows through both evaporators with each unit handling approximately one-half of the total load. When the load decreases to a customer selected load value, one of the units will be shut down by a sequence control. Since all liquid is flowing through the operating unit, that unit will cool the liquid to the desired temperature.

**Series Counter Flow Arrangement** (Refer to Figure 4, page 26) - Chillers may be applied in pairs with chilled liquid circuits connected in series and with the condenser liquid in series counter flow. All of the chilled liquid flows through both evaporators. All of the condenser liquid flows through both condensers. The liquid ranges are split, which allows a lower temperature difference or "head" on each chiller, than multiple units in parallel. For equal chillers, the machine at higher temperature level will typically provide slightly more than half the capacity.

Series counter flow application can provide a significant

building energy savings for large capacity plants which have chilled and condenser liquid temperature ranges greater than typical AHRI requirements.

## GLYCOL APPLICATIONS

The YVWA chiller is a good match for the high head requirements of low temperature glycol applications. This is particularly true of thermal ice storage systems, typically requiring 14°F (-10°C) to 40°F (4.4°C) leaving brine temperatures. This performance is enhanced with the standard thermal storage control mode described in the Accessories and Options section (see page 8).

Particular attention must be paid to the application of two or more chillers with evaporators in parallel or series when the brine temperature is below 32°F (0°C). The glycol **MUST NOT** flow through the evaporator of the idle chiller because it can cause the condenser liquid to freeze. A bypass or other type of arrangement I required that shuts off flow to the idle evaporator. When units are applied in series with lead/leg capability, the units should be identical.

## HEAT PUMP

The YVWA can act as a heat pump, extracting heat from the chilled water loop. The heat pump must have sufficient load on the condenser (heating) side to carry away the heat of compression of the system. The design working pressure (DWP) of the condenser vessel is one of the limiting factors for hot water production. If the load is less than the heat of compression load plus the refrigeration effect on the condenser side of the heat pump, the system will not be able to stay online. Heat pump mode and chiller/heat recovery capacity controls operation are mutually exclusive operational modes. The chiller mode produces cold water at setpoint, and any hot water recovered is simply a benefit. The heat pump mode produces hot water at setpoint and any cold water recovered is simply a benefit. Whichever limitation is reached first becomes the limiting factor and the heat pump will unload based on low water temperature or high discharge pressure.

## HEAT RECOVERY

Heat recovery allows the utilization of heat that would otherwise be “wasted” (to the cooling tower), to serve a useful purpose. This heat of rejection can be used to:

- Pre-heat domestic hot water needs like in hotels or hospitals for use in laundry, showers, swimming pools, cooking/dishwashing, or hot tubs.
- Comfort heating (perimeter heating).
- Reheating of air.
- Preheating of boiler makeup water or process hot water.

Heat recovery may be used in buildings where there is

a need for concurrent heating and cooling loads. Overall operating energy savings result from utilizing some or all of the heat rejection of a normal vapor-compression cycle cooling system. Heat recovery uses available heat as a by-product from the cooling function, which differs from heat pumps where the heating can be considered the primary process. Also, the heat recovery usage is often a winter seasonal duty, where the chiller may be expected to operate in summer using heat rejection to a conventional cooling tower. As heating loops and cooling tower water circuits are separate in the majority of buildings, this dictates the need for two water circuits in the condenser of a heat recovery chiller.

The main difference between a cooling only chiller and a heat recovery chiller is in the heat recovery chiller’s added ability to reject the “free condenser heat” to the cooling tower and/or the heating system. Since heat is being removed from the area to be cooled, the cooling load supports the heating load. There must be a simultaneous cooling and heating load in the building.

For heat recovery and heat pump applications, the VSD will be cooled by the chilled liquid from the unit.

## REFRIGERANT RELIEF PIPING

Each independent circuit is equipped with dual pressure relief valves on the condenser and dual relief valves on the evaporator. Refer to Table 3. The dual relief valves on the condenser are redundant and allow changing of either valve while the unit is fully charged. The purpose of the relief valves is to quickly relieve excess pressure of the refrigerant charge to the atmosphere as a safety precaution in the event of an emergency such as a fire. They are set to relieve at an internal pressure as noted on the pressure vessel data plate, and are provided in accordance with ASHRAE 15 safety code and ASME or applicable pressure codes.

Sized to the requirements of applicable codes, a vent line must run from the relief device to the outside of the building. This refrigerant relief piping must include a cleanable, vertical leg dirt trap to catch vent-stack condensation. Vent piping must be arranged to avoid imposing a strain on the relief connection and should include one flexible connection.

## SOUND AND VIBRATION CONSIDERATIONS

A YVWA chiller is not a source of objectionable sound and vibration in normal air conditioning applications. Optional neoprene isolation mounts are available with each unit to reduce vibration transmission. Optional level-adjusting spring isolator assemblies designed for 1” (25 mm) static deflection are also available for more isolation.

## Application Data - continued

YVWA chiller sound pressure level ratings will be furnished on request. Control of sound and vibration transmission must be taken into account in the equipment room construction as well as in the selection and installation of the equipment.

### THERMAL INSULATION

No appreciable operating economy can be achieved by thermally insulating the chiller. However, the chiller's cold surfaces should be insulated with a vapor barrier insulation sufficient to prevent condensation. A chiller can be factory-insulated with 3/4" (19 mm) or 1-1/2" (38 mm) thick insulation, as an option. This insulation will normally prevent condensation in environments with dry bulb temperatures of 50°F to 90°F (10°C to 32°C) and relative humidity up to 75% [3/4" (19 mm) thickness] or 90% [1-1/2" (38 mm) thickness]. The insulation is painted and the surface is flexible and reasonably resistant to wear. It is intended for a chiller installed indoors and, therefore, no protective covering of the insulation is usually required. If insulation is applied to the water boxes at the job site, it must be removable to permit access to the tubes for routine maintenance.

### VENTILATION

The ASHRAE Standard 15 Safety Code for Mechanical Refrigeration requires that all machinery rooms be vented to the outdoors utilizing mechanical ventilation by one or more fans. This standard, plus National Fire Protection Association Standard 90A, state, local and any other related codes should be reviewed for specific requirements. Since the YVWA chiller motor is hermetically sealed, no additional ventilation is needed due to motor heat.

In addition, the ASHRAE Standard 15 requires a refrigerant vapor detector to be employed for all refrigerants. It is to be located in an area where refrigerant from a leak would be likely to concentrate. An alarm is to be activated and the mechanical ventilation started at a value no great-

er than the TLV (Threshold Limit Value) of the refrigerant.

### ELECTRICAL CONSIDERATIONS

Unit input conductor size must be in accordance with the National Electrical Code (N.E.C.), or other applicable codes, for the unit full load amperes (FLA). Please refer to the submittal drawings for the FLA and minimum circuit ampacity (MCA) specific to each application. Flexible conduit should be used for the last several feet to the chiller in order to provide vibration isolation. Table 4 lists the allowable variation in voltage supplied to the chiller. The unit nameplate is stamped with the unit voltage, and frequency.

**Starters** – A separate starter is not required since the YVWA chiller is equipped with a factory installed unit mounted VSD.

**Controls** – No field control wiring is required since the VSD is factory installed as standard. The chiller including VSD is completely controlled by the control panel.

**Copper Conductors** – Only copper conductors should be connected to compressor motors and starters. Aluminum conductors have proven to be unsatisfactory when connected to copper lugs. Aluminum oxide and the difference in thermal conductivity between copper and aluminum cannot guarantee the required tight connection over a long period of time.

**Power-factor Correction Capacitors** – The VSD provides automatic displacement power-factor correction to a minimum of 0.95 at all operating conditions, so additional capacitors are not required.

**Branch Circuit Overcurrent Protection** – The branch circuit overcurrent protection device(s) should be a time-delay type, with a minimum rating equal to the next standard fuse/breaker rating above the calculated value. Refer to the submittal drawings for the specific calculations for each application.

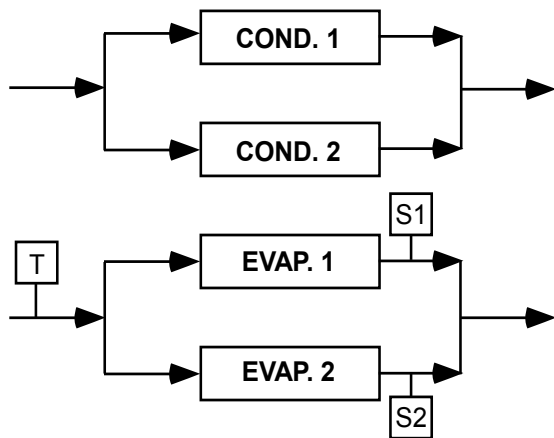

**S** – Temperature Sensor for Chiller Capacity Control  
**T** – Thermostat for Chiller Capacity Control

**FIGURE 2 – PARALLEL EVAPORATORS PARALLEL CONDENSERS**

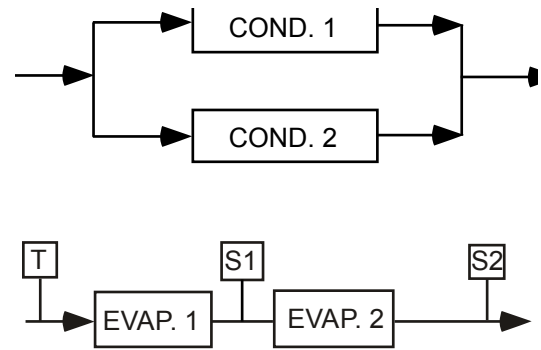

**S** – Temperature Sensor for Chiller Capacity Control  
**T** – Thermostat for Chiller Capacity Control

**FIG. 3 – SERIES EVAPORATORS PARALLEL CONDENSERS**

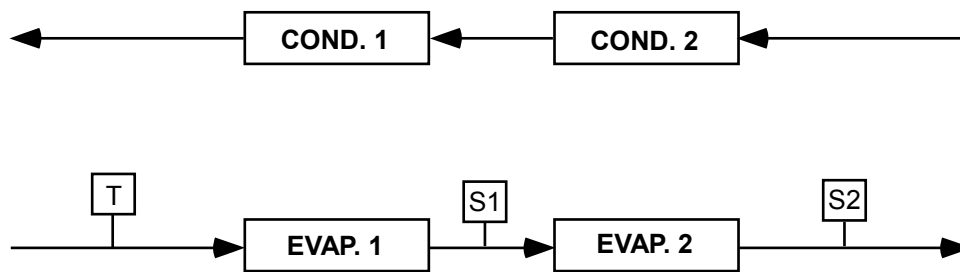

**FIGURE 4 – SERIES EVAPORATORS SERIES-COUNTER FLOW CONDENSERS**

**TABLE 1 – WATER FLOW RATE LIMITS IN GPM (L/S) – BASED UPON STANDARD TUBES @ DESIGN FULL LOAD CONDITIONS**

SINGLE COMPRESSOR	PIN 5, 6	EVAPORATOR				CONDENSER					
		2 PASS		3 PASS		1 PASS		2 PASS		3 PASS	
		MIN	MAX	MIN	MAX	MIN	MAX	MIN	MAX	MIN	MAX
SINGLE COMPRESSOR	BB	240	750	160	490	390	1560	190	780	130	520
		(15)	(47)	(10)	(31)	(25)	(98)	(12)	(49)	(8)	(33)
	BC	280	870	190	570	440	1780	220	890	150	590
		(18)	(55)	(12)	(36)	(28)	(112)	(14)	(56)	(9)	(37)
	BD	330	910	220	660	480	1950	240	910	-	-
		(21)	(57)	(14)	(42)	(30)	(123)	(15)	(57)	-	-
	CB	240	750	160	490	390	1560	190	780	130	520
		(15)	(47)	(10)	(31)	(25)	(98)	(12)	(49)	(8)	(33)
	CC	280	870	190	570	440	1780	220	890	150	590
		(18)	(55)	(12)	(36)	(28)	(112)	(14)	(56)	(9)	(37)
	CD	330	910	220	660	480	1950	240	910	-	-
		(21)	(57)	(14)	(42)	(30)	(123)	(15)	(57)	-	-
DB	240	750	160	490	390	1560	190	780	130	520	
	(15)	(47)	(10)	(31)	(25)	(98)	(12)	(49)	(8)	(33)	
DC	280	870	190	570	440	1780	220	890	150	590	
	(18)	(55)	(12)	(36)	(28)	(112)	(14)	(56)	(9)	(37)	
DD	330	910	220	660	480	1950	240	910	-	-	
	(21)	(57)	(14)	(42)	(30)	(123)	(15)	(57)	-	-	

**TABLE 2 – WATER FLOW RATE LIMITS IN L/S – BASED UPON STANDARD TUBES AT DESIGN FULL LOAD CONDITIONS**

DUAL COMPRESSOR	PIN 5, 6	EVAPORATOR				CONDENSER					
		2 PASS		3 PASS		1 PASS		2 PASS		3 PASS	
		MIN	MAX	MIN	MAX	MIN	MAX	MIN	MAX	MIN	MAX
	MB/NB	230 (15)	910 (57)	160 (10)	600 (38)	470 (30)	1850 (117)	240 (15)	920 (58)	160 (10)	610 (38)
	MC/NC	290 (18)	1140 (72)	190 (12)	750 (47)	550 (35)	2190 (138)	280 (18)	1090 (69)	190 (12)	720 (45)
	MD/ND	330 (21)	1310 (83)	220 (14)	870 (55)	610 (38)	2420 (153)	310 (20)	1200 (76)	210 (13)	800 (50)
	ME/NE	380 (24)	1490 (94)	250 (16)	980 (62)	720 (45)	2840 (179)	360 (23)	1420 (90)	240 (15)	940 (59)
	M2/N2	230 (15)	890 (56)	150 (9)	580 (37)	460 (29)	1820 (115)	230 (15)	890 (56)	160 (10)	600 (38)
	M3/N3	270 (17)	1050 (66)	180 (11)	690 (44)	560 (35)	2220 (140)	280 (18)	1100 (69)	190 (12)	740 (47)
	M4/N4	310 (20)	1230 (78)	210 (13)	800 (50)	660 (42)	2600 (164)	330 (21)	1300 (82)	220 (14)	850 (54)
	M5/N5	370 (23)	1460 (92)	250 (16)	960 (61)	750 (47)	2960 (187)	380 (24)	1480 (93)	250 (16)	980 (62)

**TABLE 3 – RELIEF VALVES WITH ISOLATION**

LOCATION	SINGLE PRESSURE RELIEF VALVE			DUAL PRESSURE RELIEF VALVE		
	NOMEN-CLATURE	PRESSURE SETTING	FLOW RATE	NOMEN-CLATURE	PRESSURE SETTING	FLOW RATE
EVAP	1-1/4-12UNF-2B SINGLE	235 psig (16.2 bar)	39.6 lb. Air/min (0.299 kg Air/sec)	1-1/4-12UNF-2B DUAL	235 psig (16.2 bar)	39.6 lb. Air/min (0.299 kg Air/sec)
COND	1-1/4-12UNF-2B DUAL	388 psig (26.8 bar)	59.4 lb. Air/min (0.449 kg Air/sec)	1-1/4-12UNF-2B DUAL	388 psig (26.8 bar)	59.4 lb. Air/min (0.449 kg Air/sec)
OIL SEP	1 NPTF SINGLE	388 psig (26.8 bar)	90.3 lb. Air/min (0.683 kg Air/sec)	1 NPTF DUAL	388 psig (26.8 bar)	90.3 lb. Air/min (0.683 kg Air/sec)

**TABLE 4 – RELIEF VALVES WITHOUT ISOLATION**

LOCATION	NOMENCLATURE	PRESSURE SETTING	FLOW RATE
EVAP	1-1/4-12UNF-2B DUAL	235 psig (16.2 bar)	39.6 lb. Air/min (0.299 kg Air/sec)
COND	1-1/4-12UNF-2B DUAL	388 psig (26.8 bar)	59.4 lb. Air/min (0.449 kg Air/sec)
OIL SEP	N/A		

# Guide Specifications

## PART 1 - GENERAL

### 1.01 GENERAL REQUIREMENTS

The requirements of this Section shall conform to the general provisions of the Contract, including General and Supplementary Conditions, Contract Drawings, and Conditions of the Contract.

### 1.02 SCOPE

Provide Microprocessor controlled, twin-screw compressor, water-cooled, liquid chillers of the scheduled capacities as shown and indicated on the Drawings, including but not limited to:

- A. Chiller package
- B. Charge of refrigerant and oil
- C. Electrical power and control connections
- D. Chilled liquid connections
- E. Condenser liquid connections
- F. Manufacturer start-up

### 1.03 QUALITY ASSURANCE

- A. Products shall be Designed, Tested, Rated and Certified in accordance with, and Installed in compliance with applicable sections of the following Standards and Codes:
  1. AHRI 550/590 – Water Chilling Packages Using the Vapor Compression Cycle.
  2. GB/T 18430.1 - water chilling (heat pump) packages using the vapor compression cycle - Part 1: Water chilling (heat pump) packages for industrial, commercial and similar application.
  3. AHRI 575 – Method of Measuring Machinery Sound Within an Equipment Space.
  4. ANSI/ASHRAE 15 – Safety Code for Mechanical Refrigeration.
  5. ANSI/ASHRAE 34 – Number Designation and Safety Classification of Refrigerants.
  6. ASHRAE 90.1 – Energy Standard for Buildings Except Low-Rise Residential Buildings.
  7. ANSI/NFPA 70 – National Electrical Code (N.E.C.).
  8. GB150/151 - Steel Pressure Vessels/Tubular Heat Exchangers..
  9. Conform to Intertek Testing Services for construction of chillers and provide ETL/cETL Listed Mark.
- B. Factory Run Test: Chiller shall be pressure-tested, evacuated and fully charged with refrigerant and oil,

and shall be factory operational run tested with water flowing through the vessel.

- C. Chiller manufacturer shall have a factory trained and supported service organization.
- D. Warranty: Manufacturer shall Warrant all equipment and material of its manufacture against defects in workmanship and material for a period of eighteen (18) months from date of shipment or twelve (12) months from date of start-up, whichever occurs first.

### 1.04 DELIVERY AND HANDLING

- A. Unit shall be delivered to job site fully assembled with all interconnecting refrigerant piping and internal wiring ready for field installation and charged with refrigerant and oil by the Manufacturer.
- B. Provide protective covering over vulnerable components for unit protection during shipment. Fit nozzles and open ends with cloth enclosures.
- C. Unit shall be stored and handled per Manufacturer's instructions.

## PART 2 - PRODUCTS

### 2.01 MANUFACTURERS

- A. The design shown on the Drawings is based on YORK model YVWA chiller manufactured by Johnson Controls. Alternate equipment will be acceptable if the manufacturer's equipment meets the scheduled performance and complies with these specifications. If equipment manufactured by a manufacturer other than that scheduled is utilized, then the Mechanical Contractor shall be responsible for coordinating with the General Contractor and all affected Subcontractors to insure proper provisions for installation of the furnished unit. This coordination shall include, but not be limited to, the following:
  1. Structural supports for units.
  2. Piping size and connection/header locations.
  3. Electrical power requirements and wire/conduit and overcurrent protection sizes.
  4. Chiller physical size on plant layout.
  5. Site noise considerations.
- B. The Mechanical Contractor shall be responsible for all costs incurred by the General Contractor, Subcontractors, and Consultants to modify the building provisions to accept the furnished alternate equipment.

## Guide Specifications - continued

### 2.02 GENERAL

- A. Description: Furnish, Install, and Commission factory assembled, charged, and operational run tested water-cooled screw compressor chiller as specified herein and shown on the Drawings. Chiller shall include, but is not limited to: semi hermetic twin screw compressors, shell and tube hybrid falling film type evaporator, flooded condenser, HFC-134a refrigerant, lubrication system, interconnecting wiring, safety and operating controls including capacity controller, control center, motor starting components, and special features as specified herein or required for safe, automatic operation.
- B. Operating Characteristics:
1. Chiller will be installed in an indoor location and shall be capable of operating in room temperatures between 40°F and 110°F (4.4°C and 43.3°C).
  2. Provide capacity control system capable of reducing unit capacity to 20% of full load. Compressor shall start in unloaded condition. Application of factory installed hot gas bypass shall be acceptable as required to meet specified minimum load.
- C. Chiller shall be completely factory-packaged including evaporator, condenser, compressor, motor, control center and all interconnecting unit piping and wiring. The complete chiller assembly shall be painted to meet 500 hour salt spray test in accordance with the ASTM B117 standard.
- D. Shipping: Unit shall ship in one piece and shall require installer to provide the evaporator and condenser inlet and outlet pipe connections. If providing chiller model that ships in multiple pieces, bid shall include all the material and field labor costs for factory authorized personnel to connect the pieces as well as all interconnecting piping and wiring.

### 2.03 COMPRESSOR(S)

- A. Compressor(s): Shall be direct drive, semi hermetic, rotary twin-screw type, including: terminal box, and precision machined cast iron housing. Design working pressure of entire compressor, suction to discharge, shall be 450 psig (31 barg) or higher. Compressor shall be U.L. recognized.
- B. Compressor Motors: Refrigerant suction-gas cooled accessible hermetic compressor motor, full suction gas flow through 80 mesh screen, with inherent inter-

nal thermal protection and external current overload on all three phases.

- C. Balancing Requirements: All rotating parts shall be statically balanced.
- D. Lubrication System: External oil separators with no moving parts, 388 psig (26.8 barg) design working pressure (Saturated discharge temperature 49°C above), and 235 psig (16.2 barg) design working pressure (Saturated discharge temperature 49°C and below), and GB listing shall be provided on the chiller. Refrigerant system differential pressure shall provide oil flow through service replaceable, 0.5 micron, full flow, cartridge type oil filter. Filter bypass, less restrictive media, or oil pump not acceptable.
- E. Capacity Control: Compressors shall start at minimum load. Provide Microprocessor control to command compressor capacity to balance compressor capacity with cooling load.

### 2.04 REFRIGERANT CIRCUIT COMPONENTS

- A. Refrigerant: HFC-134a. Classified as Safety Group A1 according to ASHRAE 34.
- B. Each refrigerant circuit shall incorporate an electronic expansion valve controlled by the control center to meter refrigerant flow to the evaporator to accommodate varying head and load conditions.
- C. Equipment supplied shall comply with LEED Energy & Atmosphere Credit 4, Enhanced Refrigerant Management.
- D. Each refrigerant circuit shall incorporate all components necessary for the designed operation.  
**[OPTIONAL]:** Refrigerant isolation valves shall be provided to isolate the referent into the condenser for standard water chilling application.

### 2.05 HEAT EXCHANGERS

- A. Evaporator:
1. Evaporator shall be shell and tube, hybrid falling film type with 2 pass arrangement to optimize efficiency and refrigerant charge. Tubes shall be high-efficiency, internally and externally enhanced type copper tubes with 0.025" (0.625 mm) minimum wall thickness at all intermediate

tube supports to provide maximum tube wall thickness at the support area. Each tube shall be roller expanded into the tube sheets providing a leak proof seal, and be individually replaceable.

**[OPTIONAL]:** 3 pass arrangement.

2. Constructed and tested in accordance with applicable sections of GB pressure vessel code for minimum 235 psig (16 barg) refrigerant side design working pressure and 150 psig (10 barg) liquid side design working pressure.
3. Water boxes shall be removable to permit tube cleaning and replacement. Liquid nozzle connections shall be HG raised-face welded flanges. Companion flanges, bolts, nuts, and gaskets are not included.

**[OPTIONAL]:** 150 psig (10.3 barg) HG raised-face weldable flanges. Flanges are field-welded by Contractor. Companion flanges, bolts, nuts, and gaskets are not included. Also available in 300 psig (20.6 barg).

**[OPTIONAL]:** 150 psig (10.3 barg) GB raised-face weldable flanges. Flanges are field-welded by Contractor. Companion flanges, bolts, nuts, and gaskets are not included. Also available in 300 psig (20.6 barg).

#### B. Condenser:

1. Condenser shall be shell and tube type, with a discharge gas baffle to prevent direct high velocity impingement on the tubes and to distribute the refrigerant gas flow evenly over the tubes. An integral sub-cooler shall be located at the bottom of the condenser shell providing highly effective liquid refrigerant subcooling and highest cycle efficiency.
2. Constructed and tested in accordance with applicable sections of GB pressure vessel code for minimum 235 psig (16.2 barg) refrigerant side design working pressure and 150 psig (10 barg) liquid side design working pressure.
3. Water boxes shall be removable to permit tube cleaning and replacement. Liquid nozzle connections shall be HG raised-face welded flanges. Companion flanges, bolts, nuts, and gaskets are not included.
4. Connection location: Chilled liquid inlet and outlet nozzle connections shall be located as shown on schedule.

## 2.06 INSULATION

- A. Material: Closed-cell, flexible, UV protected, thermal insulation complying with ASTM C 534 Type 2 (Sheet) for preformed flexible elastomeric cellular thermal insulation in sheet and tubular form.
- B. Thickness: 3/4" (19mm.)  
**[OPTIONAL]:** 1-1/2" (38mm.)  
**[OPTIONAL]:** 3/4" (19mm) for condenser with heat recovery heat pump option only.
- C. Thermal conductivity: 0.26 (BTU/HR-Ft<sup>2</sup>-°F/in) maximum at 75°F mean temperature.
- D. Factory-applied insulation over cold surfaces of liquid chiller components including evaporator shell, suction line, liquid nozzles and water box.
- E. Adhesive: As recommended by insulation manufacturer and applied to 100 percent of insulation contact surface including all seams and joints.

## 2.07 ACOUSTICAL DATA

- A. Provide unweighted sound power or sound pressure level data in decibels (dB) at the scheduled eight (8) octave band center frequencies. A-weighted sound data alone is not acceptable.
- B. Provide all sound power or sound pressure level data at 100%, 75%, 50%, and 25% load.
- C. Supplied equipment shall not exceed scheduled sound power or sound pressure level data at any load point. The mechanical Contractor shall be responsible for any additional costs associated with equipment deviation.
- D. Acoustical performance shall be evaluated in accordance with AHRI Standard - 575 test data.  
**[OPTIONAL]:** Provide factory-installed sound reduction treatment to meet chiller sound levels scheduled at all load points.

## 2.08 POWER AND ELECTRICAL REQUIREMENTS

- A. Power/Control Panel:
  1. Factory installed and wired NEMA 1, powder painted steel cabinets with tool lockable, hinged, latched, and gasket sealed outer doors equipped with door latch. Provide main power connection(s), compressor starters, current overloads, and factory wiring.

## Guide Specifications - continued

### [OPTIONAL] NEMA 3R

- B. Single Point Power:
1. Provide single point power connection to chiller, shall be 3 phase of scheduled voltage.
  2. Single Point Circuit Breaker: A unit-mounted Circuit Breaker with external lockable handle shall be supplied to isolate power voltage for servicing. Incoming power wiring must comply with local codes. Circuit breaker shall be sized to provide chiller equipment with the branch circuit protection, short circuit protection.
- C. **Control Transformer:** Power panel shall be supplied with a factory mounted and wired control transformer that will supply all unit control voltage from the main unit power supply. Transformer shall utilize scheduled line voltage on the primary side and provide 115V/1Ø on secondary.
- D. Short Circuit Withstand Rating of the chiller electrical enclosure shall be (380, 400, & 415V: minimum of 30,000 Amps [OR 65,000 Amps for Single Point Circuit Breaker].) Rating shall be published in accordance with UL508.
- E. Motor Starters: Motor starters shall be zero electrical inrush current (Variable Frequency Drives) for minimum electrical inrush. Open transition Wye-Delta and Across the Line type starters will not be acceptable.
- F. Power Factor:
1. Provide equipment with power factor correction capacitors as required to maintain a displacement power factor of 95% at all load conditions.
  2. The installing contractor is responsible for additional cost to furnish and install power factor correction capacitors if they are not factory mounted and wired.
- G. All exposed power wiring shall be routed through liquid-tight non-metallic conduit.
- H. Supplied equipment shall not exceed scheduled Minimum Circuit Ampacity (MCA.) The mechanical Contractor shall be responsible for any additional costs associated with equipment deviation.
2. Chiller shall automatically reset to normal chiller operation after power failure.
- [OPTIONAL] Heat pump shall automatically reset to normal heat pump operation after power failure.
3. Unit operating software shall be stored in non-volatile memory. Field programmed set points shall be retained in lithium battery backed regulated time clock (RTC) memory for minimum 5 years.
4. Alarm controls shall be provided to remote alert for any unit or system safety fault.
- B. Display and Keypad:
1. Provide minimum 80 character liquid crystal display that is both viewable in direct sunlight and has LED backlighting for nighttime viewing. Provide one keypad and display panel per chiller.
  2. Display and keypad shall be accessible without opening main control/electrical cabinet doors.
  3. Display shall provide a minimum of unit setpoints, status, electrical data, temperature data, pressures, safety lockouts and diagnostics without the use of a coded display.
  4. Descriptions in English (or available language options), numeric data in English (or Metric) units.
  5. Sealed keypad shall include unit On/Off switch.
- C. Programmable Setpoints (within Manufacturer limits): Display language, chilled liquid cooling mode, local/remote control mode, display units mode, remote temperature reset, remote current limit, remote heat recovery kit, leaving chilled liquid setpoint and range, maximum remote temperature reset.
- [OPTIONAL] Leaving condenser liquid setpoint and range for heat pump application.
- D. Display Data: Chilled liquid leaving and entering temperatures; flow switch status; evaporator/condenser pump status; active remote control; evaporator pressure, discharge, and oil pressures, condenser and economizer pressures per refrigerant circuit; economizer temperature and superheat; subcooler liquid temperature and superheat; compressor discharge temperature and superheat, motor; temperatures, eductor temperature, per refrigerant circuit; compressor speed, condenser level, condenser level control valve; economizer superheat; economizer feed valve percentage open; evaporator/condenser heater status; oil pump status; compressor number of

## 2.09 CONTROLS

- A. General:
1. Provide automatic control of chiller operation including compressor start/stop and load/unload, anti-recycle timer, evaporator pump, condenser

starts; run time; operating hours; history data for last ten shutdown faults; history data for last 20 normal (non-fault) shutdowns.

- E. Predictive Control Points: Unit controls shall avoid safety shutdown when operating outside design conditions by optimizing the chiller controls and cooling load output to stay online and avoid safety limits being reached. The system shall monitor the following parameters and maintain the maximum cooling output possible without shutdown of the equipment: motor current, evaporator pressure, condenser pressure, discharge pressure, starter internal ambient temperature, and starter base-plate temperature.
- F. System Safeties: Shall cause individual compressor systems to perform auto-reset shut down if: high discharge pressure or temperature, low evaporator pressure, low motor current, high/low differential oil pressure, low discharge and economizer superheat, smart freeze point protection, high motor temperature, system control voltage, eductor clog.
- G. Unit Safeties: Shall be automatic reset and cause compressors to shut down if: low leaving chilled liquid temperature, under voltage, flow switch operation. Contractor shall provide flow switch and wiring per chiller manufacturer requirements.
- H. Manufacturer shall provide any controls not listed above, necessary for automatic chiller operation. Mechanical Contractor shall provide field control wiring necessary to interface sensors to the chiller control system.
2. Gateway: Provides communication for Building Automation Systems, including BACnet (MS/TP), Modbus, N2, and LON. (Field Commissioned by BAS Manufacturer)
  3. Thermal Storage: Provide special control logic and modifications to produce leaving chilled brine temperatures below 40°F (4.4°C.)
- B. General Options:
1. Flow Switch: Vapor proof SPDT switch, 150 psig (10.3 barg), -20°F to 250°F (-28.9°C to 121.1°C.) (Field Mounted by Contractor.)
  2. Differential Pressure Switch: 3-45 psig (0.2-3 barg) range with 1/4" NPT pressure connections. (Field Mounted by Contractor.)
  3. Special Requirement Documents:
    - a. Special Requirement Document Package (SRDP) includes Pressure Vessel Report, Unit Run Test Report, Production System Check Sheet and Final Unit Inspection Check Sheet.
    - b. Materials Package includes steel mill material reports for vessels in addition to Pressure Vessel Report, Unit Run Test Report, Production System Check Sheet and Final Unit Inspection Check Sheet.
  4. Vibration Isolation (All Options Field Mounted by Contractor):
    - a. Elastomeric Isolators.
    - b. 1" Deflection Spring Isolators: Level adjustable, spring and cage type isolators for mounting under the unit base rails.

## 2.10 ACCESSORIES AND OPTIONS

Some accessories and options supersede standard product features. All options are factory-mounted unless otherwise noted.

### A. CONTROLS OPTIONS:

1. Building Automation System Interface: Chiller to accept 4 to 20mA or 0 to 10 VDC input from BAS (by others) to reset the leaving chilled liquid temperature or load limit setpoint or both.

## PART 3 - EXECUTION

### 3.01 INSTALLATION

- A. General: Rig and Install in full accordance with Manufacturer's requirements, Project drawings, and Contract documents.

- 
- B. Location: Locate chiller as indicated on drawings, including cleaning and service maintenance clearance per Manufacturer instructions. Adjust and level chiller on support structure.
  - C. Components: Installing Contractor shall provide and install all auxiliary devices and accessories for fully operational chiller.
  - D. Electrical: Coordinate electrical requirements and connections for all power feeds with Electrical Contractor.
  - E. Controls: Coordinate all control requirements and connections with Controls Contractor.
  - F. Finish: Installing Contractor shall paint damaged and abraded factory finish with touch-up paint matching factory finish.

# Unit Conversion

Values provided in this manual are in the English inch-pound (I-P) system.

The following factors can be used to convert from English to the most common SI Metric values.

MEASUREMENT	MULTIPLY THIS ENGLISH VALUE	BY	TO OBTAIN THIS METRIC VALUE
CAPACITY	TONS REFRIGERANT EFFECT (TON)	3.516	KILOWATTS (KW)
POWER	KILOWATTS (KW)	NO CHANGE	KILOWATTS (KW)
	HORSEPOWER (HP)	0.7457	KILOWATTS (KW)
FLOW RATE	GALLONS / MINUTE (GPM)	0.0631	LITERS / SECOND (L/S)
LENGTH	FEET (FT)	304.8	MILLIMETERS (MM)
	INCHES (IN)	25.4	MILLIMETERS (MM)
WEIGHT	POUNDS (LB)	0.4536	KILOGRAMS (KG)
VELOCITY	FEET / SECOND (FPS)	0.3048	METERS / SECOND (M/S)
PRESSURE DROP	FEET OF WATER (FT)	2.989	KILOPASCALS (KPA)
	POUNDS / SQ. INCH (PSI)	6.895	KILOPASCALS (K PA)

## TEMPERATURE

To convert degrees Fahrenheit (°F) to degrees Celsius (°C), subtract 32° and multiply by 5/9 or 0.5556.

To convert a temperature range (i.e., 10°F or 12°F chilled water range) from Fahrenheit to Celsius, multiply by 5/9 or 0.5556.

## FOULING FACTOR

ENGLISH I-P (ft <sup>2</sup> °F hr/Btu)	EQUIVALENT SI METRIC (m <sup>2</sup> k/kW)
0.0001	.018
0.00025	.044
0.0005	.088
0.00075	.132

## EFFICIENCY

In the English I-P system, chiller efficiency is measured in kW / ton:

$$\text{kW / ton} = \frac{\text{kW input}}{\text{tons refrigerant effect}}$$

In the SI Metric system, chiller efficiency is measured in Coefficient of Performance (COP).

$$\text{COP} = \frac{\text{kW refrigeration effect}}{\text{kW input}}$$

kW / ton and COP are related as follows:

$$\text{kW/ton} = \frac{3.516}{\text{COP}}$$

$$\text{COP} = \frac{3.516}{\text{kW/ton}}$$

Printed on recycled paper

Form 201.30-EG1 (713) Supersedes: 201.30-EG1 (413)

© 2013 Johnson Controls, Inc. P.O. Box 423, Milwaukee, WI 53201 Printed in USA  
[www.johnsoncontrols.com](http://www.johnsoncontrols.com)

