

Model YVAA Air-Cooled Screw Compressor Liquid Chillers with Variable Speed Drive Style A

150-500 Tons
525-1750 kW
2 Compressor
50 and 60 Hz
HFC-134a



BY JOHNSON CONTROLS

Nomenclature

YVAA 021 3AXX 46 AA

1 2 3 4
BASE PRODUCT TYPE

Y : York
 V : Variable Speed Screw
 A : Air cooled
 A : Design Series

5 6 7
FRAME SIZE

#

8 9 10 11
CONFIGURATION

: Condenser code
 # : Evaporator code
 # : Compressor code
 # : Condenser fan & sound kit code

12 13
VOLTAGE

1 7 : 200 / 3 / 60
 2 8 : 230 / 3 / 60
 4 0 : 380 / 3 / 60
 4 2 : 400 / 3 / 60
 4 6 : 460 / 3 / 60
 5 0 : 380-415 / 3 / 50
 5 8 : 575 / 3 / 60

14 15
LEVEL / REFRIGERANT

: Development Level
 A : Refrigerant R134a

Table of Contents

APPROVALS	3
INTRODUCTION	5
RATINGS.....	6
UNIT OVERVIEW.....	7
MICROCOMPUTER CONTROL CENTER	10
ACCESSORIES AND OPTIONS	12
REFRIGERANT FLOW DIAGRAM.....	18
APPLICATION DATA.....	19
PHYSICAL DATA - MICROCHANNEL COIL- ENGLISH (SI).....	24
PHYSICAL DATA - ROUND TUBE COIL - ENGLISH (SI)	28
EVAPORATOR OPTIONS.....	30
DIMENSIONS.....	34
RIGGING HOLE LOCATIONS.....	36
ISOLATOR LOCATIONS	40
ISOLATORS.....	46
ELECTRICAL DATA	50
POWER WIRING.....	60
CUSTOMER CONTROL WIRING.....	62
CONTROL WIRING	64
GUIDE SPECIFICATIONS	66

Approvals

- ASME Boiler and Pressure Vessel Code – Section VIII Division 1.
- AHRI Standard 550/590.
- UL 1995 – Heating and Cooling Equipment
- ASHRAE 15 – Safety Code for Mechanical Refrigeration
- ASHRAE Guideline 3 – Reducing Emission of Halogenated Refrigerants in Refrigeration and Air-Conditioning Equipment and Systems
- N.E.C. – National Electrical Code
- OSHA – Occupational Safety and Health Act

Introduction

YVAA chillers are Johnson Controls' most efficient air-cooled chillers. The design offers a lighter, smaller and quieter package that minimizes the installed cost.

For over 135 years, Johnson Controls has raised the bar of chiller design and customer expectations. We are raising the bar again with a leap forward in air-cooled chiller technology. Continuing the history of innovation in both compressor design and Variable Speed Drive (VSD) technology, Johnson Controls proudly introduces the YORK® YVAA. In the past, the choice to use an air-cooled chiller came with the expectation of compromise, where simplicity of design and maintenance were traded for performance and efficiency. The new YVAA provides a better balance by combining the best of both - a high performance design that minimizes the total cost of ownership.

YORK YVAA model air-cooled chillers provide superior performance. Higher efficiency heat exchangers coupled with variable speed operation and smart controls elevate the system efficiency to a whole new level. The resulting benefit from YVAA chillers is much greater than the sum of its parts.

Efficiency: Reduce your consumption

YVAA chillers are Johnson Controls' most efficient air-cooled chillers. The design offers a lighter, smaller and quieter package that minimizes the installed cost and maximizes usable building space. YVAA chillers are simpler in design with easy access to service components for reliable operation and efficient maintenance. With up to a 40% improvement in real world efficiency versus current products, YVAA sets the new standards for lowering energy use.

Sustainability: Improve your environmental footprint

YVAA lowers both direct and indirect impact on the environment. It uses R134a refrigerant which has zero ozone depletion potential (ODP). The design minimizes the quantity of refrigerant used in the system. Every YVAA model helps LEED projects earn the Energy and Atmosphere Credit 4. The highest portion of green house gases is carbon dioxide generated from electric power plants. HVAC systems are one of the largest consumers of electricity in commercial buildings. YVAA chillers reduce the electricity usage, thereby contributing to reducing greenhouse gases and helping keep the planet cool.

Low Sound: Quiet operation makes you a good neighbor

The variable speed technology on YVAA allows unparalleled low sound levels at off peak design conditions. This makes YVAA a great solution for sound sensitive zones. Several acoustic attenuation options such as smart controls (SilentNight™), aerodynamic fans, and effective sound enclosures allow the chiller to meet even the most stringent sound level requirements.

Confidence: Proven performance provides peace of mind

YVAA design is proven by years of success with the previous generation of YORK VSD air-cooled screw chillers with thousands of machines operating in more than one hundred countries.

YVAA is configurable to be the perfect fit for your unique needs. YVAA offers an array of options that can be tailored and tuned to match the capacity, efficiency, sound and footprint for your specific application. Several variations of condenser fans, evaporator arrangements, sound kits, protection enclosures, and controls schemes are available to meet specific requirements for your site.

Ratings

AHRI CERTIFICATION PROGRAM

The performance of the YORK YVAA chiller has been certified to the Air Conditioning, Heating, and Refrigeration Institute (AHRI) as complying with the certification sections of the latest issue of AHRI Standard 550/590. Under this Certification Program, chillers are regularly tested in strict compliance with this Standard. This provides an independent, third-party verification of chiller performance.

COMPUTERIZED PERFORMANCE RATINGS

Each chiller is custom-matched to meet the individual building load and energy requirements. A variety of standard heat exchangers and pass arrangements are available to provide the best possible match.

It is not practical to provide tabulated performance for each combination, as the energy requirements at both full and part load vary significantly with each heat exchanger and pass arrangement. Computerized ratings are available through each Johnson Controls sales office. Each rating can be tailored to specific job requirements, and is part of the AHRI Certification Program.

OFF-DESIGN PERFORMANCE

Since the vast majority of its operating hours are spent at off-design conditions, a chiller should be chosen not only to meet the full load design, but also for its ability to perform efficiently at lower loads. It is not uncommon for chillers with the same full load efficiency to have an operating cost difference of over 10% due to differences in off-design (part-load) efficiencies.

Part load information can be easily and accurately generated by use of the computer. And because it is so important to an owner's operating budget, this information has now been standardized within the AHRI Certification Program in the form of an Integrated Part Load Value (IPLV), and Non-Standard Part Load Value (NPLV).

The current IPLV/NPLV rating from AHRI Standard 550/590 much more closely tracks actual chiller operation, and provides a more accurate indication of chiller performance than the previous IPLV/APLV rating. A more detailed analysis must take into account actual building load profiles, and local weather data. Part load performance data should be obtained for each job using its own design criteria.



Rated in accordance with the latest issuance of AHRI Standard 550/590.

Unit Overview

SEMI-HERMETIC YORK TWIN SCREW COMPRESSORS

The direct-drive, semi-hermetic rotary twin-screw compressors incorporate advanced technology in a rugged design. The continuous function, microprocessor controlled VSD provides smooth capacity control from 100% down to 10% of chiller capacity. State-of-the-art technology, obtained from decades of screw compressor design and manufacturing by FRICK®, ensures optimal efficiencies at all chiller load points. With no unloading steps or slide valves in the compressors, the YVAA variable speed driven compressors have 50% fewer moving parts than fixed speed compressors with slide valves. The YVAA compressor is one of the most efficient and reliable screw compressors in the industry.

EVAPORATOR

The evaporator is a shell and tube, hybrid falling film type heat exchanger. It contains a balance of flooded and falling film technology to optimize efficiency, minimize refrigerant charge, and maintain reliable control. A specifically designed distribution system provides uniform refrigerant flow for optimum performance.

CONDENSER

The YVAA introduces the microchannel coil to the YORK screw compressor chiller line. Microchannel coils are made of a single material to avoid galvanic corrosion due to dissimilar metals. Coils and headers are brazed as one piece, minimizing leaks. The inherently rugged coil construction, which includes non-overhanging fins, eliminates the possibility of fin damage. The microchannel maximizes condenser heat transfer, resulting in a smaller footprint, and reduces refrigerant charge by as much as 50%.

The condenser fans are composed of corrosion resistant aluminum hub and glass-fiber-reinforced polypropylene composite blades molded into a low-noise airfoil section. All blades are statically and dynamically balanced for vibration-free operation. Fan motors are Totally Enclosed Air-Over (TEAO), squirrel-cage type and current protected. The direct drive motors feature double-sealed and permanently lubricated ball bearings, cutting down on maintenance cost over the life of the unit.

REFRIGERANT CIRCUIT

The YVAA has one independent refrigerant circuit per compressor. Each circuit uses copper refrigerant pipe formed on computer-controlled bending machines. By using computer-aided technology, over 60% of system piping brazed joints have been eliminated (as compared to designs that use fittings), resulting in a highly reliable and leak-resistant system.

COMPLETE FACTORY PACKAGE

Each unit is shipped as a complete factory package, completely assembled with all interconnecting refrigerant piping and internal wiring and ready for field installation. Prior to shipment, each individual chiller undergoes an extensive testing procedure, ensuring workmanship is the highest quality and that the initial start-up is trouble-free.

Before leaving the factory, each refrigerant circuit is factory pressure tested, evacuated and then fully charged with R134a refrigerant and oil. An operational test is performed with water flowing through the evaporator to ensure each circuit functions correctly.

ELECTRICAL

All controls and motor starting equipment necessary for unit operation are factory wired

and function tested. There are no surprises when you go to start-up; you can have confidence that the unit will start up right the first time and every time.

The chillers are available with a single point power connection and are supplied with a factory mounted and wired control transformer that powers all unit controls from the main unit power supply. The transformer utilizes scheduled line voltage on the primary side and provides 115V/1Ø on secondary. The standard unit is equipped with terminal block electrical connections. All exposed power wiring is routed through liquid-tight, UV-stabilized, non-metallic conduit. Selection of frame 36 and larger are standard dual point, with single point option.

VSD Power/Control Panel includes main power connection(s), VSD and fan motor contactors, current overloads, and factory wiring. All display and control features can be accessed through the keypad and control display access door, eliminating the need to open the main cabinet doors.

BUILDING AUTOMATION SYSTEM CAPABILITIES

The E-Link Gateway provides an economical and versatile connection between Johnson Controls equipment and open/standard protocols. It efficiently manages the communication protocols currently used by Johnson Controls equipment, exposing the data in a consistent, organized, and defined fashion. A simple switch selection allows configuration of the required equipment profile and output protocol, which reduces equipment connectivity startup time.

MICROCOMPUTER CONTROL CENTER

The microcomputer control center (see Figure 1) provides automatic control of chiller operation including compressor start/ stop and load/unload anti-recycle timers, condenser fans, chilled liquid pump, evaporator heater, unit alarm contacts and run signal contacts. The microcomputer control center comes online as soon as the main power switch on the unit is switched on; immediately, the microcomputer control center will begin to continuously monitor all variables.

The microprocessor controls the unit's capacity by matching the actual leaving chilled liquid temperature (LCHLT) to the user-defined setpoint. Factors that may cause the system's actual LCHLT to fluctuate are changes in ambient temperature, load, and chilled liquid loop flow rate and volume. The controls system reacts to such changes by adjusting the number of compressors that are on and the loading of each compressor in order to keep the LCHLT at the setpoint.

The controls system logic monitors the rate at which the LCWT is approaching the setpoint to ramp up or down compressor capacity as required. The variable frequency drive allows the compressor capacity to match the load.

Display Data

- Leaving Chilled Liquid Temperature
- Returning Liquid Temperature
- Ambient Temperature
- Lead System
- Compressor Capacity (% of Full Load Amps)
- VSD Output Frequency / Compressor Speed
- Compressor Run Hours
- Compressor Number of Starts
- Oil Pressure and Temperature (per Compressor)
- Chilled Liquid Pump Status
- Evaporator Heater Status
- History Data for Last Twenty Normal Shutdowns

- History Data for Last Ten Shutdown Faults
- Programmable Setpoints
- Chiller on/Off
- Chilled Liquid (Water or Glycol)
- Local or Remote Control
- Units of Measure (Imperial or SI)
- System Lead/Lag
- Remote Temperature Reset
- Remote Current Limit
- Leaving Chilled Liquid Temperature Setpoint and Range
-

Johnson Controls' systems or another vendor's systems can incorporate these setpoints and data outputs to give the customer a complete understanding of how the system is running through a Building Automation System.

Extreme Conditions - During extreme or unusual conditions (i.e. blocked condenser coils, ambient above scheduled maximum, etc.) the chiller control system will avoid shut-down by varying capacity. By monitoring motor current and suction and discharge pressures, the chiller can maintain maximum available cooling output without shutting down.

Unit Safeties are provided for the chiller to perform auto-reset shut down for the following conditions:

- Ambient temperature above or below allowable range
- Out of range leaving chilled liquid temperature
- Under voltage
- Flow switch operation

MicroComputer Control Center

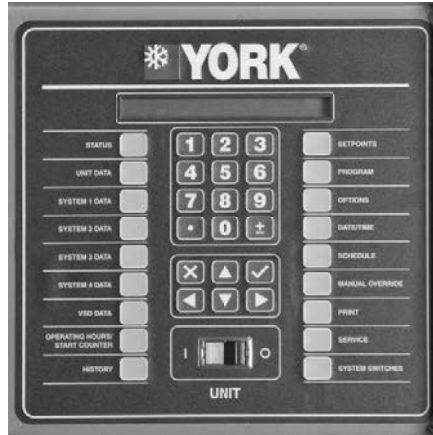

FIGURE 1 - VIEW OF YORK CONTROL CENTER KEYPAD AND DISPLAY

MICROCOMPUTER CONTROL CENTER

The microcomputer control center (see Figure 1) provides automatic control of chiller operation including compressor start/ stop and load/unload anti-recycle timers, condenser fans, chilled liquid pump, evaporator heater, unit alarm contacts and run signal contacts. The microcomputer control center comes online as soon as the main power switch on the unit is switched on; immediately, the microcomputer control center will begin to continuously monitor all variables.

The microprocessor controls the unit's capacity by matching the actual leaving chilled liquid temperature (LCHLT) to the user-defined setpoint. Factors that may cause the system's actual LCHLT to fluctuate are changes in ambient temperature, load, and chilled liquid loop flow rate and volume. The controls system reacts to such changes by adjusting the number of compressors that are on and the loading of each compressor in order to keep the LCHLT at the setpoint.

The controls system logic monitors the rate at which the LCWT is approaching the setpoint to ramp up or down compressor capacity as required. The variable frequency drive allows the compressor capacity to match the load.

Display Data

- Leaving Chilled Liquid Temperature
- Returning Liquid Temperature
- Ambient Temperature
- Lead System
- Compressor Capacity (% of Full Load Amps)
- VSD Output Frequency / Compressor Speed
- Compressor Run Hours
- Compressor Number of Starts
- Oil Pressure and Temperature (per Compressor)
- Chilled Liquid Pump Status
- Evaporator Heater Status
- History Data for Last Twenty Normal Shutdowns
- History Data for Last Ten Shutdown Faults

Programmable Setpoints

- Chiller on/Off
- Chilled Liquid (Water or Glycol)
- Local or Remote Control
- Units of Measure (Imperial or SI)
- System Lead/Lag
- Remote Temperature Reset
- Remote Current Limit
- Leaving Chilled Liquid Temperature Setpoint and Range

Johnson Controls' systems or another vendor's systems can incorporate these setpoints and data outputs to give the customer a complete understanding of how the system is running through a Building Automation System.

Extreme Conditions - During extreme or unusual conditions (i.e. blocked condenser coils, ambient above scheduled maximum, etc.) the chiller control system will avoid shut-down by varying capacity. By monitoring motor current and suction and discharge pressures, the chiller can maintain maximum available cooling output without shutting down.

Unit Safeties are provided for the chiller to perform auto-reset shut down for the following conditions:

- Ambient temperature above or below allowable range
- Out of range leaving chilled liquid temperature
- Under voltage
- Flow switch operation

Accessories and Options

All options factory mounted unless otherwise noted.

SOUND ATTENUATION

LOW NOISE KITS – The standard chiller configuration is equipped with low sound fans and acoustic treatments on the refrigerant lines and compressors. There are several sound attenuation options available to further reduce sound at its source thereby meeting local sound level regulations.

SilentNight - Due to time-of-day based sound regulations in some locations, it may be desirable to force the chiller to a lower sound level on demand. The SilentNight control option provides a control input to limit sound output of the chiller based on time of day. This feature is programmable at the chiller panel or can be controlled remotely via a signal (4-20mA or 0-10 VDC) from a BAS system.

ULTRA QUIET FANS – The chiller is equipped with specially designed fans and motors to provide lower sound levels yet retain appropriate airflow. The result is reduced fan generated sound with minimal effect on the chiller capacity or efficiency at standard AHRI conditions. The fans are three-bladed for 60Hz and five-bladed for 50Hz.

FAN OPTIONS

HIGH STATIC FANS - (380V/60 Hz, 460V/60 Hz, 400V/50 Hz) The chiller is equipped with condenser fans with higher power motors suitable for high external static pressure, up to 100Pa (0.4 in. water), across condenser coils. This option should be selected if additional airflow resistance may be present due to flow restrictions such as field installed ducts, filters, sound enclosures etc. Please contact your local Johnson Controls representative for more information.

HIGH AIRFLOW FANS - (380V/60 Hz, 460V/60 Hz, and 400V/50 Hz) The chiller is equipped with condenser fans with airfoil-type polycarbonate blades and high power motors providing extra airflow across coils. In some chiller configurations, this option can provide an increase in chiller capacity at high ambient. Please contact your local Johnson Controls representative for more information.

CONDENSER

COILS – Fin and tube condenser coils of seamless, internally-enhanced, high-condensing-coefficient, corrosion resistant copper tubes are arranged in staggered rows. The tubes are mechanically expanded into aluminum fins. Integral subcooling is included. The design working pressure of the coils is 350 PSIG (24 barg).

CONDENSER COIL PROTECTION

The aluminum alloys used in the YVAA microchannel condenser have been carefully selected and tested for high corrosion resistance. However, all metals can corrode in harsh conditions. Consider protecting coils from corrosive environments such as coastal, marine, urban and industrial.

POST-COATED EPOXY DIPPED CONDENSER – Microchannel condenser coils applied with electro-deposited and baked flexible epoxy coating that is finished with a polyurethane UV resistant top-coat suitable for highly corrosive applications.

PROTECTIVE CHILLER PANELS

WIRE PANELS – UV stabilized black polyvinyl chloride coated, heavy gauge, welded wire mesh guards mounted on the exterior of the full unit. Protects condenser coil faces and prevents unauthorized access to refrigerant components (compressors, pipes, evaporator, etc.), yet provides free air flow. This can cut installation cost by eliminating the need for separate, expensive fencing. See Figure 2.

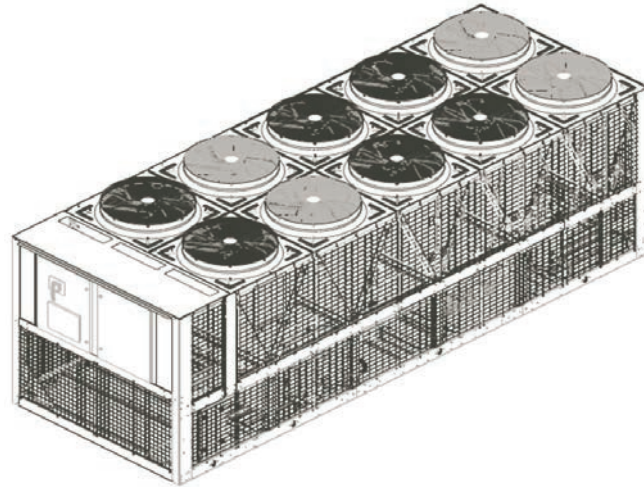

FIGURE 2 - FULL UNIT WIRE PANELS

LOUVERED PANELS – Louvered panels, painted the same color as the unit, enclose the unit to visually screen and protect the coils as well as prevent unauthorized access to internal components. Also available as a condenser-only option. See Figures 3 and 4.

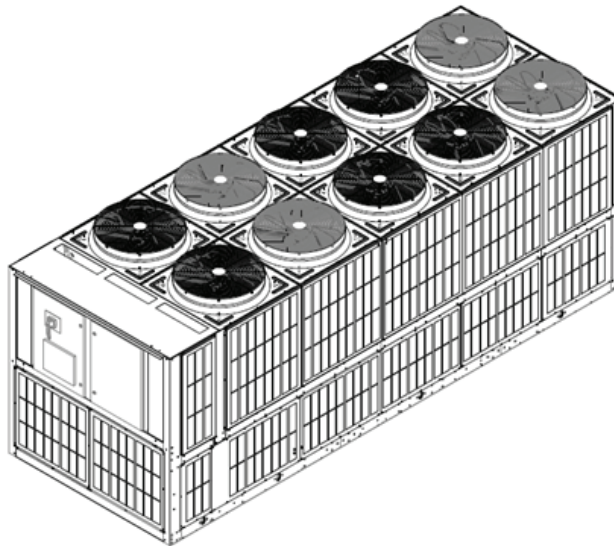

FIGURE 3 - FULL UNIT LOUVERED PANELS

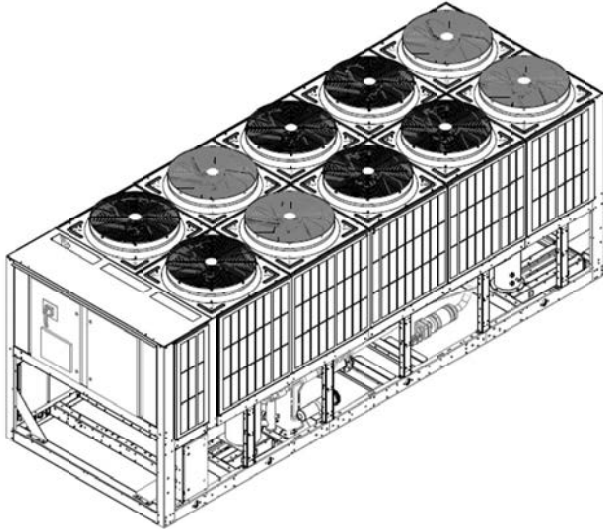

FIGURE 4 - CONDENSERS-ONLY LOUVERED PANELS

LOUVERED/WIRE PANELS COMBINATION - Louvered panels, painted the same color as the unit, are mounted on external condenser coil faces. Heavy gauge, welded wire-mesh panels, coated to resist corrosion, are mounted around base of machine to restrict unauthorized access. See Figure 5.

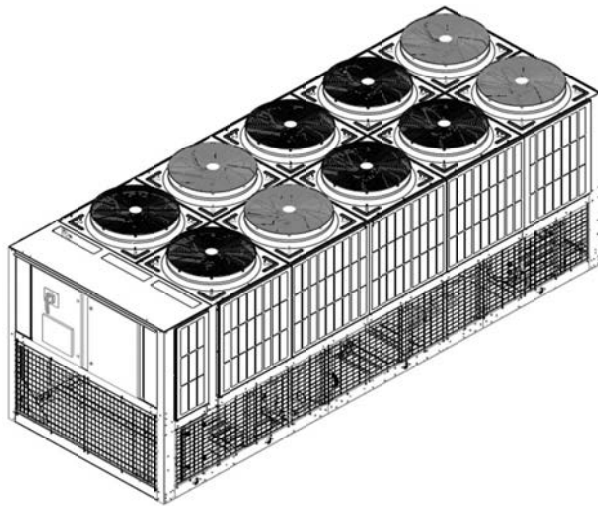

FIGURE 5 - LOUVERED/WIRE PANELS COMBINATION

END HAIL GUARD – Louvered panels, painted the same color as the unit, are installed on the rear of the unit (opposite end of the control panel) to protect the exposed condenser from flying debris or hail. See Figure 6.

V-GUARD PANELS – Solid panels, painted the same color as the unit, are installed along the sides of the units to cover exposed piping within the condenser section without impacting airflow. These guard panels can be combined with End Hail Guard option for additional protection from debris. See Figure 7.

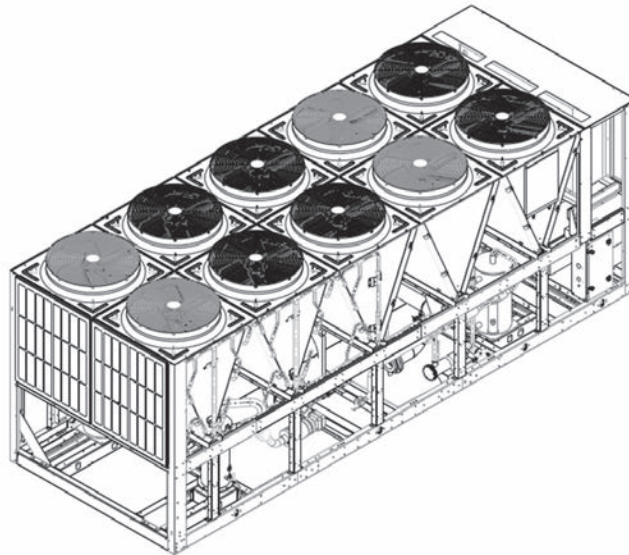

FIGURE 6 - END HAIL GUARD

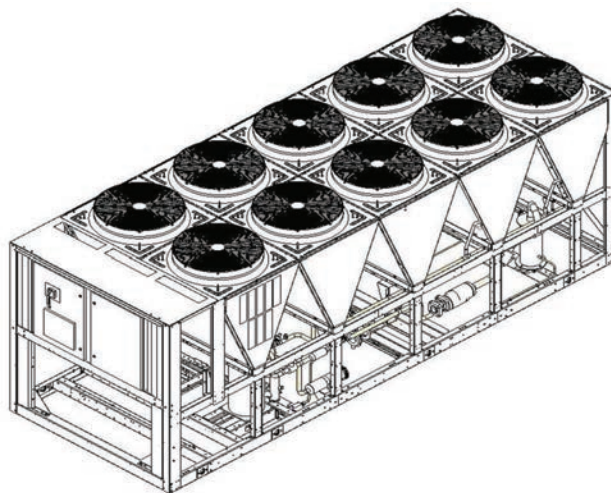

FIGURE 7 - V-GUARD OPTION

EVAPORATOR OPTIONS

1-1/2" INSULATION – Double thickness insulation provided.

FLANGE KIT – Provides contractor with the couplings best suited to tie into the chilled liquid piping. All flanges are ANSI 150 psig (10.3 barg). **Field mounted.** Options include:

- **ANSI/AWWA C-606 flanges** - 2 flanges, for applications where field piping has existing flanges.
- **ANSI/AWWA C-606 flanges** - 4 flanges, for applications where customer wants flanged connections which do not exist on the field piping.
- **Weld flanges** - 2 flanges, for customer to weld to evaporator to mate to existing flanges on field piping.
- **Weld flanges** - 4 flanges, for customer to weld to evaporator and customer wants flanged connections which do not exist on the field piping

CONNECTION LOCATION - The standard unit configuration is available with liquid inlet connections at rear (opposite control panel end) of unit. Option available for front fluid inlet on select configurations.

THREE-PASS – The standard evaporator is constructed with two chilled water passes through the evaporator. The three-pass option is recommended for use in brine applications or where a greater water temperature difference is required but efficiency cannot be sacrificed.

WATER BOX HEATER - The standard unit comes with freeze protection on the evaporator down to 0°F (-17.8°C). The waterbox heater option provides additional freeze protection down to -20°F (-28°C).

CONTROLS OPTIONS

HIGH AMBIENT OPERATION – (400V/50Hz and 380V/60Hz only) This provides special control logic coupled with high airflow fans to permit high ambient (up to 125°F (52°C)) operation. This option may also allow for increased machine capacity, allowing the selection of a smaller chassis to meet specific capacity requirements.

BUILDING AUTOMATION SYSTEM INTERFACE (TEMPERATURE) - Factory installed option to accept a 4 to 20 mA or a 0 to 10 VDC input to allow remote reset of the Leaving Chilled Liquid Temperature Setpoint. The setpoint can be positively offset upwards up to 40°F (22.2°C). This option is useful for ice storage or process applications or for periods where higher chilled liquid temperatures are adequate for low loads. Available alone or in combination with BAS Load Limit.

BUILDING AUTOMATION SYSTEM INTERFACE (LOAD LIMIT) - Factory installed option to accept a 4 to 20 mA or a 0 to 10 VDC input to allow remote reset of the Load Limit Setpoint. The setpoint can limit system demand from 30-100%. Available alone or in combination with BAS Temperature Reset.

E-Link – The E-Link gateway provides full communication to Building Automation Systems, including BACnet (MS/TP), Modbus, LON and N2.

THERMAL STORAGE – Provides special control logic and modifications to produce leaving chilled brine temperatures below 40°F (4.4°C) primarily at times of low ambient temperatures (night time). Option can be used to produce ice to supplement cooling and significantly decrease energy costs. The capability of the chiller is enhanced by using both ice and chilled liquid simultaneously during times of peak cooling needs.

GENERAL OPTIONS

FLOW SWITCH ACCESSORY - Vapor proof SPDT, NEMA 3R switch, 150 psig (10.3 barg) DWP, -20°F to 250°F (-29°C to 121°C) with 1" NPT (IPS) connection for upright mounting in horizontal pipe (This flow switch or equivalent must be furnished with each unit). **Field mounted.**

DIFFERENTIAL PRESSURE SWITCH – This 3-45 psig (0.2-3 barg) range switch, with 1/4" NPT pressure connections, is an alternative to the paddle-type flow switch. **Field mounted.**

SERVICE ISOLATION VALVE – Service suction isolation valve added to unit for each refrigerant circuit.

CHICAGO CODE RELIEF VALVE - Special relief valves per Chicago code.

DUAL PRESSURE RELIEF VALVE – Two safety relief valves are mounted in parallel; one is always operational to assist in valve replacement during maintenance.

PRESSURE VESSEL OPTIONS – The evaporator can be provided with either ASME or PED pressure vessel codes certification.

CIRCUIT BREAKER – Unit-mounted circuit breaker(s) with external lockable handle(s) will be supplied to isolate the power voltage for servicing. The circuit breaker(s) is (are) sized to provide motor branch circuit protection, short circuit protection and ground fault protection for the motor branch-circuit conductors, the motor control apparatus and the motors.

NON-FUSED DISCONNECT SWITCH – Unit-mounted disconnect switch(es) with external lockable handle can be supplied to isolate the unit power voltage for servicing. Separate external fusing must be supplied by the power wiring, which must comply with local codes.

SPECIAL REQUIREMENT DOCUMENTS – There are two options to select from:

- Special Requirement Document Package (SRDP) includes Pressure Vessel Report, Unit Run Test Report, Production System Check Sheet and Final Unit Inspection Check Sheet.
- Materials Package includes steel mill material reports for vessels in addition to the SRDP.

VIBRATION ISOLATION

ELASTOMERIC ISOLATION – This option is recommended for normal installations. It provides very good performance in most applications for the least cost. **Field mounted.**

1" SPRING ISOLATORS – Spring and cage type isolators for mounting under the unit base rails are available to support unit. They are level adjustable. 1" nominal deflection may vary slightly by application. **Field mounted.**

2" RESTRAINED SPRING ISOLATORS – Restrained Spring-Flex Mounting isolators incorporate a rugged welded steel housing with vertical and horizontal limit stops. Housings designed to withstand a minimum 1.0g accelerated force in all directions up to 2" (51mm). The deflection may vary slightly by application. They are level adjustable. **Field mounted.**

Refrigerant Flow Diagram

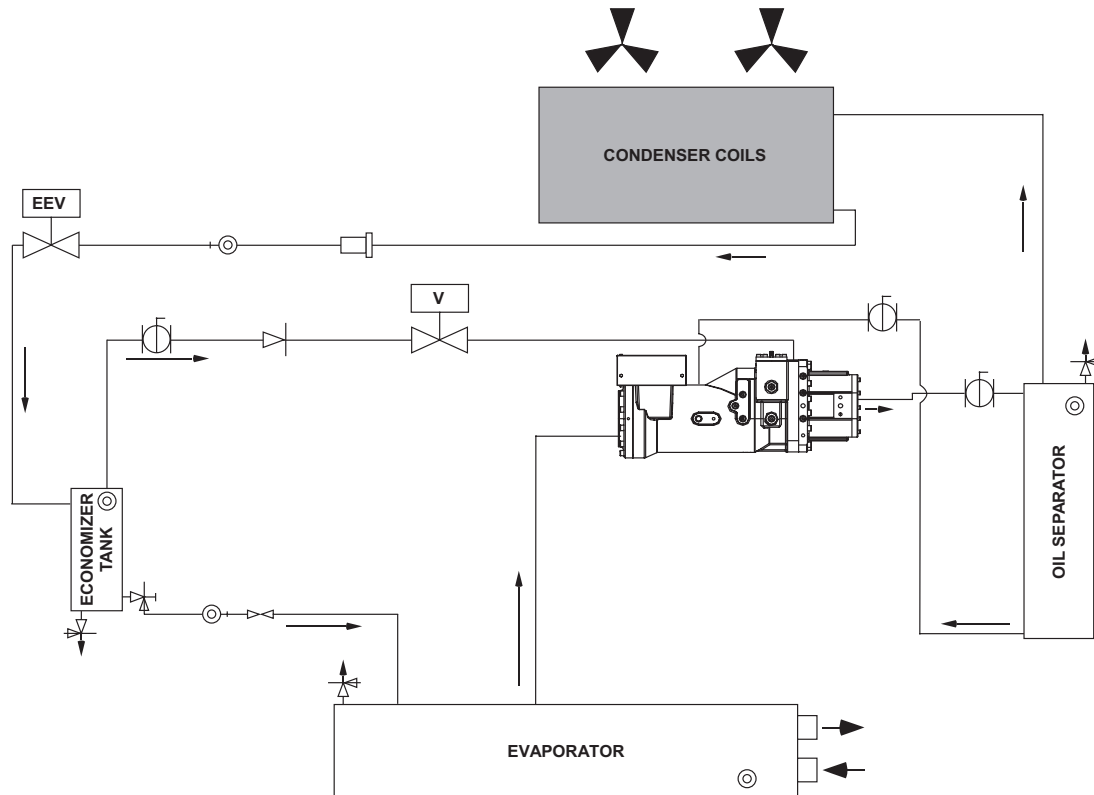

Symbol	YVAA System Component
	Electronic Expansion Valve
	Ball Valve
	Relief Valve
	Stop Valve Angle, Access
	Replaceable Core Filter/Dryer
	Sight Glass
	Orifice
	Check Valve
	Valve

Low pressure refrigerant (liquid and gas) enters the evaporator and is sprayed across the top of the tube bundle from spray nozzles. The liquid refrigerant from the nozzles gravity drains down across the tube bundle and is evaporated and superheated by the heat energy absorbed from the chilled liquid passing through the tubes.

The low pressure refrigerant vapor leaves the top of the evaporator and enters the compressor where the refrigerant vapor is compressed and the pressure and superheat are increased. The high pressure superheated gas enters the air cooled condenser where heat is rejected via the condenser coils and fans.

The fully condensed and sub-cooled liquid leaves the air cooled condenser, flows through the filter drier and enters the economizer tank. The flow of refrigerant into the economizer is controlled by the electronic expansion valve.

Additional cooling of the refrigerant liquid may take place in the economizer tank when the economizer valve is opened. After leaving the economizer tank, liquid refrigerant flows through an orifice where pressure reduction and further cooling take place. The low pressure refrigerant (liquid and gas) then enters the evaporator.

Application Data

UNIT SIZING

Avoid over-sizing a chiller. Properly sized chillers operate stably and provide the best life cycle cost. When designing phased projects, select multiple small chillers to match demand for each phase. Use multiple small chillers when the minimum cooling demand is less than 10% of the maximum cooling demand.

UNIT LOCATION

The YVAA chillers are designed for outdoor installation. To achieve optimum performance and trouble-free service provide adequate space around chillers (see Figure 8). When selecting chiller installation sites, follow these requirements:

- A. Installation sites may be either on a roof or on ground level. (See **FOUNDATION**)
- B. Provide space for air to flow into condensers per dimensions shown on the dimension drawing on pgs 20 and 21. Restricted airflow or hot air recirculation will diminish performance. Johnson Controls' unit controls will optimize the operation without nuisance high pressure safety cutouts; however, the system designer **MUST** consider potential performance degradation. Recommended clearances (See Fig. 8) for all units are as follows:

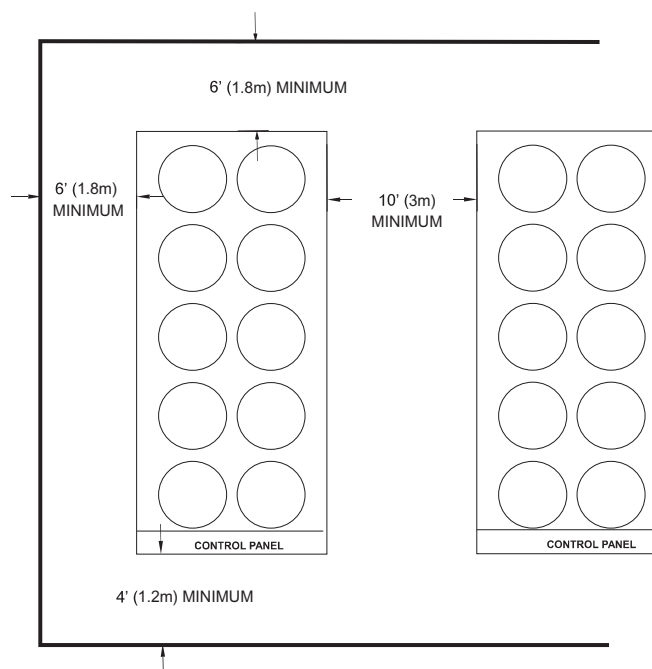

FIGURE 8 - ACCEPTABLE MINIMUM CLEARANCES AROUND/BETWEEN UNIT(S) FOR PROPER AIRFLOW

1. Access to the unit control center stipulates the unit is no higher than on spring isolators.
2. Recommended minimum clearances:
 - a. Side to wall – 6' (1.8m)
 - b. Rear to wall – 6' (1.8m)

- c. Control panel end to wall – 4' (1.2m)
 - d. Top – no obstructions whatsoever
 - e. Distance between adjacent units – 10' (3m)
3. No more than one wall around the chiller yard should be higher than the chiller(s)
- C. Avoid locations near windows or structures where normal operating sounds may be objectionable.
- D. The condenser fans are propeller-type and are not recommended for use with duct-work, filters or other impediments to airflow in the condenser air stream.
- E. When obstructions to airflow exist, they must not add more than 0.1" external static pressure.
- F. Protection against corrosive environments is available by ordering the units with cured epoxy-coating on the condenser microchannel. Epoxy-coated coils should be used with any units being installed at the seashore, or where salt spray may hit the units, or where acid rain is prevalent.
- G. On installations where winter operation is intended and snow accumulations are expected, additional elevation must be provided to insure normal condenser air flow.
- H. Provide adequate space for tubes to be removed from evaporator. For clearances please contact your nearest Johnson Controls Sales Office.

FOUNDATION

Mount units on a flat and level foundation, ground or roof, capable of supporting the entire operating weight of the equipment. Please contact your nearest Johnson Controls Sales Office for shipping and operating weights.

Roof Locations – Provide structure to safely support the entire weight of the unit and service personnel. Do not damage the roof during installation. If the roof is "bonded", consult a building contractor or architect for special installation requirements. Use spring isolators to minimize vibration transmission into building structure. Provide additional structural support at the spring-isolator locations.

Ground Locations – Units must be installed on a sub-stantial base that will not settle and cause strain on the refrigerant lines, resulting in possible leaks. A one-piece concrete slab, with footers extending below the frost line is recommended. The slab should not be tied to the main building foundation as operational noise will telegraph. Mounting holes (5/8") are provided in the base rails for bolting the unit to its foundation. See ISOLATOR LOCATIONS on page 54 for location of the mounting holes.

For ground installations, precautions should be taken to protect the unit from tampering by, or injury to, unauthorized persons. Fasteners on access panels will prevent casual tampering; however, further safety precautions such as unit enclosure options, a fenced-in enclosure, or locking devices on the panels may be advisable. Check local authorities for safety regulations.

Seismic Applications – Avoid installing chillers on springs or roofs where earthquakes are a risk. Springs and roofs amplify earthquake forces. Rigidly mounting chillers to ground level concrete pads is typically the best option for earthquake zones. Contact Johnson Controls equipment specialists for help with projects that have seismic requirements.

CHILLED LIQUID PIPING

Design the chilled liquid piping system so that the circulating pump discharges into the evaporator. The inlet and outlet evaporator-liquid connections are given in DIMENSIONS on pg 22. Hand stop valves are recommended in all lines to facilitate servicing. Provide drain connections at low points to permit complete drainage of the evaporator and system piping.

The evaporator must be protected by a strainer, preferably of 40 mesh, fitted as close as possible to the liquid inlet connection, and provided with a means of local isolation.

The evaporator must not be exposed to flushing velocities or debris released during flushing. It is recommended that a suitably sized bypass and valve arrangement is installed to allow flushing of the piping system. The bypass can be used during maintenance to isolate the heat exchanger without disrupting flow to other units.

Pressure-gauge connections are recommended for installation in the inlet and outlet liquid lines. Gauges are not provided with the unit and are to be furnished by others.

Chilled liquid lines exposed to the weather should be wrapped with a supplemental heater cable and insulated, or glycol should be added to the chilled liquid to protect against freezing if low-ambient periods are expected.

A flow switch is available as an accessory on all units. A flow switch must be installed in the leaving liquid piping of the evaporator and must not be used to start and stop the unit.

MINIMUM LIQUID VOLUME

It is good practice to include as much liquid volume as possible in a chilled liquid loop. This increases the thermal mass and “Flywheel” effect within the system (i.e. the more the better) which in turn promotes stable liquid temperature control and increases reliability by reducing compressor cycling.

For air conditioning applications, a minimum of 3 gallons/ton (3.2 liters/cooling KW) is recommended. It is preferred that the gallon/ton ratio be within the 5 to 8 (5.4 to 8.6 liter/cooling KW) range for constant flow rate chilled liquid systems. See **VARIABLE PRIMARY FLOW** for recommendations for VPF systems. For process applications, a minimum of 6 gallons/ton (6.5 liter/cooling KW) ratio is recommended with preference towards a range of 7 to 11 (7.5 to 11.8). Install a tank or increase pipe sizes to provide sufficient liquid volume.

LEAVING LIQUID TEMPERATURE OUT OF RANGE

The YVAA chiller line has a maximum leaving liquid temperature of 60°F (15.6°F). Some process applications require a chilled liquid temperature higher than what the chiller provides. In those applications, a simple piping change can remove the problem. By using a mixture of chiller-cooled liquid and returning process liquid, the chilled liquid entering the process can be held at the desired temperature. (A tank can also be used to meet high leaving liquid temperature requirements.) (See Figure 9)

FLOW RATE OUT OF RANGE

Each YVAA evaporator has a minimum and maximum flow rate. Some process applications require a flow rate that is out of range for the evaporator. In those applications, a piping change can remove the problem.

In applications where the required flow rate is less than the evaporator’s minimum allowable, the chilled liquid can be recirculated to the chiller. (See Figure 10)

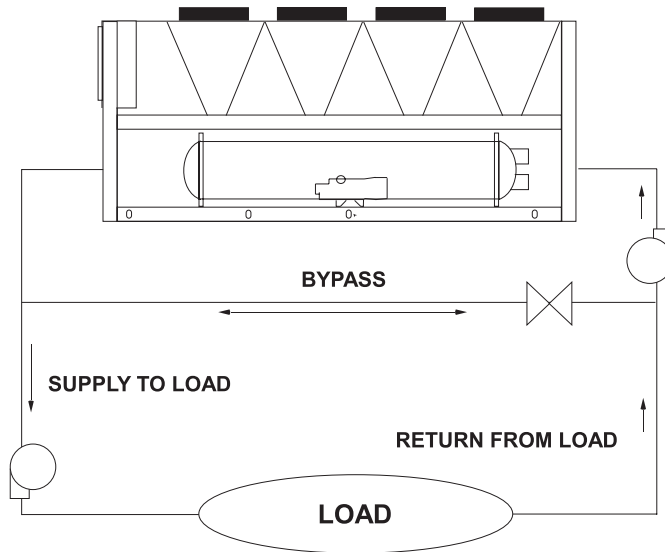

FIGURE 9 - LEAVING LIQUID TEMPERATURE OUT OF RANGE SUGGESTED LAYOUT

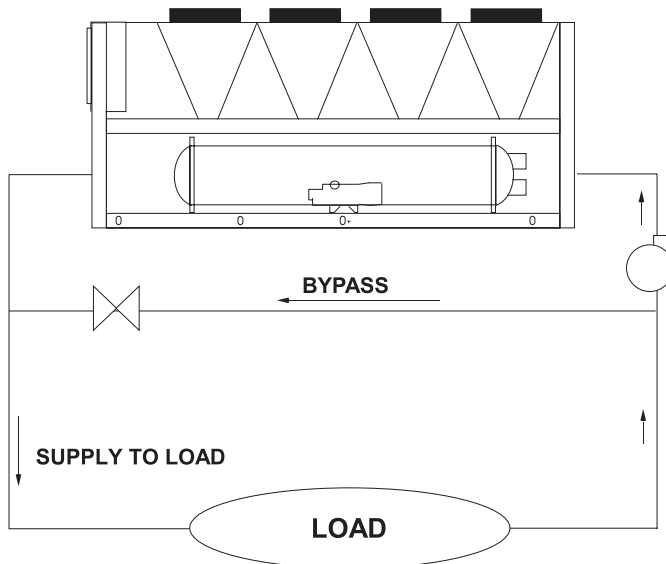

FIGURE 10 - SUGGESTED LAYOUT FOR APPLICATIONS WITH A FLOW RATE GREATER THAN THE EVAPORATOR MAXIMUM ALLOWABLE FLOW RATE

In applications where the required flow rate is greater than the evaporator's maximum allowable, the chilled liquid can be recirculated to the load (see Figure 11).

THERMAL STORAGE

Thermal storage is the practice of storing cooling energy during a period of little or no load and/or low energy costs for use during periods of high load and/or energy costs. Conventional cooling systems produce cooling when it is needed which is commonly during times of peak demand. Thermal storage allows generation of cooling capacity to occur during off-peak periods and store that capacity to meet future cooling requirements. Using thermal storage can result in smaller equipment sizes, thereby reducing capital cost, and also can result in significant energy cost savings.

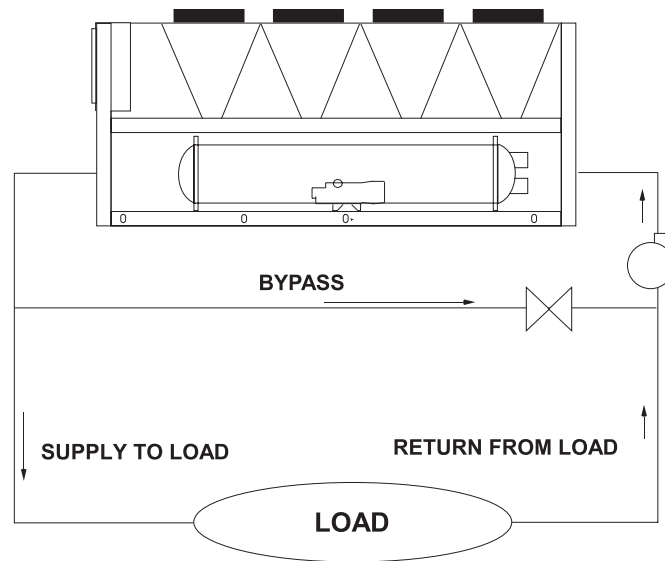

FIGURE 11 - SUGGESTED LAYOUT FOR APPLICATIONS WITH A FLOW RATE LESS THAN THE EVAPORATOR MINIMUM ALLOWABLE FLOW RATE

The YVAA has special control logic to be able to produce chilled leaving brine temperatures below 40°F (4.4°C) so as to supply a storage tank with chilled liquid during times of low demand. YVAA chillers selected for thermal storage operation can also be selected to efficiently provide chilled liquid at nominal cooling loads.

VARIABLE PRIMARY FLOW

Johnson Controls recommends a maximum 10% per minute flow rate of change, based on design flow, for variable primary flow applications. Eight to 10 gallons per chiller ton (8.6 to 10.8 liter per cooling KW) is recommended for the system liquid volume. Insufficient system volume and rapid flow changes can cause control problems or can even cause chiller shutdowns. There are many other design issues to evaluate with variable primary flow systems. Consult your Johnson Controls Sales Office for more information about successfully applying YVAA chillers.

Physical Data - Microchannel Coil- English (SI)

The data shown in this table is applicable to selected typical configurations. Other configurations are available through our configuration/selection software. Please contact your nearest Johnson Controls Sales Office for the chiller configuration that best matches your specific needs.

UNIT FRAME	15	16	17	18	19	19	20	21	21
CONDENSER CODE	3	5	8	3	5	8	0	3	5
EVAPORATOR CODE	B	B	C	A	A	B	C	A	C
GENERAL UNIT DATA									
Number of Independent Refrigerant Circuits	2								
Refrigerant Charge, R-134a, Ckt.-1/Ckt.-2, lbs (kg)	175/175 (79/79)	190/190 (86/86)	225/225 (102/102)	175/155 (79/70)	190/170 (86/77)	220/195 (100/88)	205/205 (93/93)	175/175 (79/79)	225/225 (102/102)
Oil Charge, Ckt.-1/Ckt.-2, gal (liters)	2.1/2.0 (8.0/7.7)	2.2/2.2 (8.5/8.5)	2.5/2.5 (9.3/9.3)	2.4/2.0 (9.2/7.7)	2.6/2.1 (9.7/8.0)	2.7/2.2 (10.4/8.5)	2.6/2.6 (10.0/10.0)	2.5/2.5 (9.3/9.3)	2.8/2.8 (10.5/10.5)
Minimum Load (%)	10%								
Unit shipping weight, lbs (kg) ¹	11518 (5224)	12084 (5481)	14668 (6653)	12019 (5452)	12781 (5797)	13776 (6248)	13392 (6074)	12859 (5833)	14915 (6765)
Operating Weight, lbs (kg) ¹	11979 (5434)	12546 (5691)	15432 (7000)	12460 (5652)	13222 (5997)	14237 (6458)	14155 (6421)	13300 (6033)	15678 (7111)
Chassis Dimensions - Length, inches (mm)	203.3 (5163)	247.2 (6280)	291.2 (7397)	247 (6274)	291.2 (7397)	335.2 (8514)	226 (5741)	291.2 (7397)	291.2 (7397)
Chassis Dimensions - Width, inches (mm)	88.3 (2242)	88.3 (2242)	88.3 (2242)	88.3 (2242)	88.3 (2242)	88.3 (2242)	88.3 (2242)	88.3 (2242)	88.3 (2242)
Chassis Dimensions - Height, inches (mm)	94.6 (2403)	94.6 (2403)	94.6 (2403)	94.6 (2403)	94.6 (2403)	94.6 (2403)	94.6 (2403)	94.6 (2403)	94.6 (2403)
COMPRESSORS, SEMI-HERMETIC SCREW									
Qty per Chiller	2								
CONDENSER FANS									
Number Ckt-1/Ckt-2	4/4	5/5	6/6	6/4	7/5	8/6	4/4	6/6	6/6
Air on Condenser (Min/Max), °F (°C)	0/125 (-17.8/51.7)								
EVAPORATOR, SHELL AND TUBE HYBRID FALLING FILM ²									
Water Volume, gal (liters)	58 (220)	58 (220)	71 (269)	48 (182)	48 (182)	58 (220)	71 (269)	48 (182)	71 (269)
Leaving Water Temperature (Min/Max), °F (°C) ³	40/60 (4.4/15.6)								
Maximum Water Side Pressure, psig (barg)	150 (10.3)								
Maximum Refrigerant Side Pressure, psig (barg)	235 (16.2)								
Evap Drain Connection, inches (mm)	3/4								

NOTES:

- Shipping and operating weights shown are for base unit; selected options may add weight to unit. Contact your nearest Johnson Controls Sales office for weight data.
- The evaporator is protected against freezing to 0°F(-17.8°C) with a standard heater.
- For leaving liquid temperature below 40°F(4.4°C) or above 60°F (15.6°C), contact your nearest Johnson Controls Sales Office for application requirements.

The data shown in this table is applicable to selected typical configurations. Other configurations are available through our configuration/selection software. Please contact your nearest Johnson Controls Sales Office for the chiller configuration that best matches your specific needs.

UNIT FRAME	21	23	24	24	26	27	27	27	29	30
CONDENSER CODE	8	3	5	8	3	3	5	8	5	3
EVAPORATOR CODE	C	B	C	C	B	D	E	E	E	C
GENERAL UNIT DATA										
Number of Independent Refrigerant Circuits	2									
Refrigerant Charge, R-134a, Ckt.-1/Ckt.-2, lbs (kg)	240/240 (109/109)	210/190 (95/86)	250/225 (113/102)	250/250 (113/113)	210/210 (95/95)	265/265 (120/120)	265/265 (120/120)	270/270 (122/122)	310/265 (141/120)	290/245 (132/111)
Oil Charge, Ckt.-1/Ckt.-2, gal (liters)	2.9/2.9 (10.8/10.8)	2.7/2.6 (10.1/9.7)	2.9/2.8 (11.1/10.5)	2.9/2.9 (11.1/11.1)	2.7/2.7 (10.1/10.1)	3.0/3.0 (11.4/11.4)	3.0/3.0 (11.4/11.4)	3.1/3.1 (11.6/11.6)	4.2/3.1 (15.9/11.7)	4.1/3.0 (15.5/11.4)
Minimum Load (%)	10%									
Unit shipping weight, lbs (kg) ¹	15677 (7111)	13288 (6027)	15873 (7200)	16634 (7545)	14076 (6385)	16275 (7382)	16991 (7707)	17753 (8052)	18205 (8258)	17114 (7763)
Operating Weight, lbs (kg) ¹	16440 (7457)	13750 (6237)	16636 (7546)	17398 (7891)	14538 (6594)	17103 (7758)	17851 (8097)	18612 (8442)	19065 (8648)	17877 (8109)
Chassis Dimensions - Length, inches (mm)	335.2 (8514)	291.2 (7397)	335.2 (8514)	379.1 (9631)	335.2 (8514)	335.2 (8514)	335.2 (8514)	379.2 (9631)	379.2 (9631)	379.2 (9631)
Chassis Dimensions - Width, inches (mm)	88.3 (2242)	88.3 (2242)	88.3 (2242)	88.3 (2242)	88.3 (2242)	88.3 (2242)	88.3 (2242)	88.3 (2242)	88.3 (2242)	88.3 (2242)
Chassis Dimensions - Height, inches (mm)	94.6 (2403)	94.6 (2403)	94.6 (2403)	94.6 (2403)	94.6 (2403)	94.6 (2403)	94.6 (2403)	94.6 (2403)	94.6 (2403)	94.6 (2403)
COMPRESSORS, SEMI-HERMETIC SCREW										
Qty per Chiller	2									
CONDENSER FANS										
Number Ckt-1/Ckt-2	7/7	7/5	8/6	8/8	7/7	7/7	7/7	8/8	9/7	9/7
Air on Condenser (Min/Max), °F (°C)	0/125									
EVAPORATOR, SHELL AND TUBE HYBRID FALLING FILM ²										
Water Volume, gal (liters)	71 (269)	58 (220)	71 (269)	71 (269)	58 (220)	82 (310)	113 (428)	113 (428)	113 (428)	71 (269)
Leaving Water Temperature (Min/Max), °F (°C) ³	40/60 (4.4/15.6)									
Maximum Water Side Pressure, psig (barg)	150 (10.3)									
Maximum Refrigerant Side Pressure, psig (barg)	235 (16.2)									
Evap Drain Connection, inches (mm)	3/4									

NOTES:

- Shipping and operating weights shown are for base unit; selected options may add weight to unit. Contact your nearest Johnson Controls Sales office for weight data.
- The evaporator is protected against freezing to 0°F (-17.8°C) with a standard heater.
- For leaving liquid temperature below 40°F (4.4°C) or above 60°F (15.6°C), contact your nearest Johnson Controls Sales Office for application requirements.

The data shown in this table is applicable to selected typical configurations. Other configurations are available through our configuration/selection software. Please contact your nearest Johnson Controls Sales Office for the chiller configuration that best matches your specific needs.

UNIT FRAME	30	30	31	32	33	34	34	36	37
CONDENSER CODE	5	8	8	3	3	3	5	8	3
EVAPORATOR CODE	C	E	E	E	C	E	E	J	F
GENERAL UNIT DATA									
Number of Independent Refrigerant Circuits	2								
Refrigerant Charge, R-134a, Ckt.-1/Ckt.-2, lbs (kg)	295/250 (134/114)	315/275 (143/125)	315/295 (143/134)	295/295 (134/134)	290/290 (132/132)	310/310 (141/141)	315/315 (143/143)	475/320 (216/145)	420/245 (191/111)
Oil Charge, Ckt.-1/Ckt.-2, gal (liters)	4.1/3.0 (15.5/11.4)	4.3/3.2 (16.3/12.1)	4.3/3.3 (16.3/12.5)	4.1/4.1 (15.5/15.5)	4.1/4.1 (15.5/15.5)	4.2/4.2 (15.9/15.9)	4.3/4.3 (16.3/16.3)	5.6/5.0 (21.2/19.0)	5.3/2.9 (20.1/11.0)
Minimum Load (%)	10%								
Unit shipping weight, lbs (kg) ¹	17875 (8108)	18967 (8603)	19728 (8948)	18554 (8416)	18224 (8266)	19315 (8761)	20077 (9107)	24831 (11263)	22346 (10136)
Operating Weight, lbs (kg) ¹	18638 (8454)	19827 (8993)	20588 (9339)	19414 (8806)	18987 (8612)	20175 (9151)	20937 (9497)	26188 (11879)	23405 (10616)
Chassis Dimensions - Length, inches (mm)	423.1 (10748)	423.1 (10748)	467.1 (11865)	379.2 (9631)	423.1 (10748)	423.1 (10748)	467.1 (11865)	511 (12979)	467.1 (11864)
Chassis Dimensions - Width, inches (mm)	88.3 (2242)	88.3 (2242)	88.3 (2242)	88.3 (2242)	88.3 (2242)	88.3 (2242)	88.3 (2242)	88.3 (2243)	88.3 (2243)
Chassis Dimensions - Height, inches (mm)	94.6 (2403)	94.6 (2403)	94.6 (2403)	94.6 (2403)	94.6 (2403)	94.6 (2403)	94.6 (2403)	94.7 (2405)	94.7 (2405)
COMPRESSORS, SEMI-HERMETIC SCREW									
Qty per Chiller	2								
CONDENSER FANS									
Number Ckt-1/Ckt-2	10/8	10/8	8/8	8/8	9/9	9/9	10/10	14/8	13/7
Air on Condenser (Min/Max), °F (°C)	0/125 (-17.8/51.7)								
EVAPORATOR, SHELL AND TUBE HYBRID FALLING FILM ²									
Water Volume, gal (liters)	71 (269)	113 (428)	113 (428)	113 (428)	71 (269)	113 (428)	113 (428)	147 (556)	96 (363)
Leaving Water Temperature (Min/Max), °F (°C) ³	40/60 (4.4/15.6)								
Maximum Water Side Pressure, psig (barg)	150 (10.3)								
Maximum Refrigerant Side Pressure, psig (barg)	235 (16.2)								
Evap Drain Connection, inches (mm)	3/4								

NOTES:

- Shipping and operating weights shown are for base unit; selected options may add weight to unit. Contact your nearest Johnson Controls Sales office for weight data.
- The evaporator is protected against freezing to 0°F(-17.8°C) with a standard heater.
- For leaving liquid temperature below 40°F(4.4°C) or above 60°F (15.6°C), contact your nearest Johnson Controls Sales Office for application requirements.

The data shown in this table is applicable to selected typical configurations. Other configurations are available through our configuration/selection software. Please contact your nearest Johnson Controls Sales Office for the chiller configuration that best matches your specific needs.

UNIT FRAME	37	39	41	42	42	44	47	48	50	52
CONDENSER CODE	5	8	3	5	8	3	5	3	0	3
EVAPORATOR CODE	J	J	H	H	J	G	J	G	J	J
GENERAL UNIT DATA										
Number of Independent Refrigerant Circuits	2									
Refrigerant Charge, R-134a, Ckt.-1/Ckt.-2, lbs (kg)	470/310 (213/141)	475/360 (216/163)	460/345 (209/156)	480/365 (218/166)	475/385 (215/175)	370/370 (168/168)	445/445 (202/202)	385/385 (175/175)	405/405 (184/184)	445/445 (202/202)
Oil Charge, Ckt.-1/Ckt.-2, gal (liters)	5.6/4.3 (21.2/16.3)	5.6/5.1 (21.2/19.3)	5.5/4.3 (20.8/16.3)	5.6/4.4 (21.2/16.7)	5.6/5.1 (21.2/19.3)	5.0/5.0 (18.9/18.9)	5.4/5.4 (20.4/20.4)	5.1/5.1 (19.3/19.3)	5.2/5.2 (19.7/19.7)	5.4/5.4 (20.4/20.4)
Minimum Load (%)	10%									
Unit shipping weight, lbs (kg) ¹	24070 (10918)	25941 (11767)	21242 (9635)	22765 (10326)	26703 (12112)	25942 (11767)	28427 (12894)	26704 (12113)	25968 (11779)	28427 (12894)
Operating Weight, lbs (kg) ¹	25426 (11533)	27298 (12382)	22049 (10001)	23572 (10692)	28060 (12728)	27001 (12247)	29784 (13510)	27763 (12593)	27325 (12394)	29784 (13510)
Chassis Dimensions - Length, inches (mm)	467.1 (11864)	555.3 (14104)	467.1 (11864)	555.3 (14104)	599.3 (15222)	555.3 (14104)	599.3 (15222)	599.3 (15222)	467.1 (11865)	599.3 (15222)
Chassis Dimensions - Width, inches (mm)	88.3 (2243)	88.3 (2243)	88.3 (2243)	88.3 (2243)	88.3 (2243)	88.3 (2243)	88.3 (2243)	88.4 (2244)	88.3 (2243)	88.3 (2243)
Chassis Dimensions - Height, inches (mm)	94.7 (2405)	94.7 (2405)	94.7 (2405)	94.7 (2405)	94.7 (2405)	94.7 (2405)	94.7 (2405)	94.7 (2405)	94.7 (2405)	94.7 (2405)
COMPRESSORS, SEMI-HERMETIC SCREW										
Qty per Chiller	2									
CONDENSER FANS										
Number Ckt-1/Ckt-2	13/7	14/10	12/8	14/10	14/12	12/12	13/13	13/13	10/10	13/13
Air on Condenser (Min/Max), °F (°C)	0/125									
EVAPORATOR, SHELL AND TUBE HYBRID FALLING FILM ²										
Water Volume, gal (liters)	147 (556)	147 (556)	130 (492)	130 (492)	147 (556)	96 (363)	147 (556)	96 (363)	147 (556)	147 (556)
Leaving Water Temperature (Min/Max), °F (°C) ³	40/60 (4.4/15.6)									
Maximum Water Side Pressure, psig (barg)	150 (10.3)									
Maximum Refrigerant Side Pressure, psig (barg)	235 (16.2)									
Evap Drain Connection, inches (mm)	3/4									

NOTES:

- Shipping and operating weights shown are for base unit; selected options may add weight to unit. Contact your nearest Johnson Controls Sales office for weight data.
- The evaporator is protected against freezing to 0°F (-17.8°C) with a standard heater.
- For leaving liquid temperature below 40°F (4.4°C) or above 60°F (15.6°C), contact your nearest Johnson Controls Sales Office for application requirements.

Physical Data - Round Tube Coil - English (SI)

The data shown in this table is applicable to selected typical configurations. Other configurations are available through our configuration/selection software. Please contact your nearest Johnson Controls Sales Office for the chiller configuration that best matches your specific needs.

UNIT FRAME	15	18	21	23	26	27	30
CONDENSER CODE	3	3	3	3	3	3	3
EVAPORATOR CODE	B	A	A	B	B	D	C
GENERAL UNIT DATA							
Number of Independent Refrigerant Circuits	2						
Refrigerant Charge, R-134a, Ckt.-1/Ckt.-2, lbs (kg)	285/285 (129/129)	340/265 (154/120)	340/340 (154/154)	403/327 (183/148)	403/403 (183/183)	458/458 (208/208)	538/437 (244/198)
Oil Charge, Ckt.-1/Ckt.-2, gal (liters)	2.1/2.0 (8.0/7.7)	2.4/2.0 (9.2/7.7)	2.5/2.5 (9.3/9.3)	2.7/2.6 (10.1/9.7)	2.7/2.7 (10.1/10.1)	3.0/3.0 (11.4/11.4)	4.1/3.0 (15.5/11.4)
Minimum Load (%)	10%						
Unit shipping weight, lbs (kg) ¹	12354 (5224)	13064 (5926)	14113 (6402)	14542 (6596)	15539 (7048)	17738 (8046)	18786 (8521)
Operating Weight, lbs (kg) ¹	12815 (5813)	13505 (6126)	14554 (6602)	15004 (6806)	16001 (7258)	18566 (8421)	19549 (8867)
Chassis Dimensions - Length, inches (mm)	203.3 (5163)	247 (6274)	291.2 (7397)	291.2 (7397)	335.2 (8514)	335.2 (8514)	379.2 (9631)
Chassis Dimensions - Width, inches (mm)	88.3 (2242)	88.3 (2242)	88.3 (2242)	88.3 (2242)	88.3 (2242)	88.3 (2242)	88.3 (2242)
Chassis Dimensions - Height, inches (mm)	94.6 (2403)	94.6 (2403)	94.6 (2403)	94.6 (2403)	94.6 (2403)	94.6 (2403)	94.6 (2403)
COMPRESSORS, SEMI-HERMETIC SCREW							
Qty per Chiller	2						
CONDENSER FANS							
Number Ckt-1/Ckt-2	4/4	6/4	6/6	7/5	7/7	7/7	9/7
Air on Condenser (Min/Max), °F (°C)	0/125 (-17.8/51.7)						
EVAPORATOR, SHELL AND TUBE HYBRID FALLING FILM ²							
Water Volume, gal (liters)	58 (220)	48 (182)	48 (182)	58 (220)	58 (220)	82 (310)	71 (269)
Leaving Water Temperature (Min/Max), °F (°C) ³	40/60 (4.4/15.6)						
Maximum Water Side Pressure, psig (barg)	150 (10.3)						
Maximum Refrigerant Side Pressure, psig (barg)	235 (16.2)						
Evap Drain Connection, inches (mm)	3/4						

NOTES:

- Shipping and operating weights shown are for base unit; selected options may add weight to unit. Contact your nearest Johnson Controls Sales office for weight data.
- The evaporator is protected against freezing to 0°F(-17.8°C) with a standard heater.
- For leaving liquid temperature below 40°F(4.4°C) or above 60°F (15.6°C), contact your nearest Johnson Controls Sales Office for application requirements.

The data shown in this table is applicable to selected typical configurations. Other configurations are available through our configuration/selection software. Please contact your nearest Johnson Controls Sales Office for the chiller configuration that best matches your specific needs.

UNIT FRAME	32	33	34	37	41	44	48	52
CONDENSER CODE	3	3	3	3	3	3	3	3
EVAPORATOR CODE	E	C	E	F	H	G	G	J
GENERAL UNIT DATA								
Number of Independent Refrigerant Circuits	2							
Refrigerant Charge, R-134a, Ckt.-1/Ckt.-2, lbs (kg)	515/515 (234/234)	538/538 (244/244)	558/558 (253/253)	778/437 (353/198)	790/565 (358/256)	700/700 (318/318)	743/743 (337/337)	803/803 (364/364)
Oil Charge, Ckt.-1/Ckt.-2, gal (liters)	4.1/4.1 (15.5/15.5)	4.1/4.1 (15.5/15.5)	4.2/4.2 (15.9/15.9)	5.3/2.9 (20.1/11.0)	5.5/4.3 (20.8/16.3)	5.0/5.0 (18.9/18.9)	5.1/5.1 (19.3/19.3)	5.4/5.4 (20.4/20.4)
Minimum Load (%)	10%							
Unit shipping weight, lbs (kg) ¹	20226 (9174)	20105 (9119)	21196 (9614)	24436 (11084)	23332 (10583)	28450 (12905)	29421 (13345)	31144 (14127)
Operating Weight, lbs (kg) ¹	21086 (9504)	20868 (9466)	22056 (10004)	25495 (11564)	24139 (10949)	29509 (13385)	30480 (13826)	32501 (14742)
Chassis Dimensions - Length, inches (mm)	379.2 (9631)	423.1 (10748)	423.1 (10748)	467.1 (11864)	467.1 (11864)	555.3 (14104)	599.3 (15222)	599.3 (15222)
Chassis Dimensions - Width, inches (mm)	88.3 (2242)	88.3 (2242)	88.3 (2242)	88.3 (2243)	88.3 (2243)	88.3 (2243)	88.4 (2244)	88.3 (2243)
Chassis Dimensions - Height, inches (mm)	94.6 (2403)	94.6 (2403)	94.6 (2403)	94.7 (2405)	94.7 (2405)	94.7 (2405)	94.7 (2405)	94.7 (2405)
COMPRESSORS, SEMI-HERMETIC SCREW								
Qty per Chiller	2							
CONDENSER FANS								
Number Ckt-1/Ckt-2	8/8	9/9	9/9	13/7	12/8	12/12	13/13	13/13
Air on Condenser (Min/Max), °F (°C)	0/125 (-17.8/51.7)							
EVAPORATOR, SHELL AND TUBE HYBRID FALLING FILM ²								
Water Volume, gal (liters)	113 (428)	71 (269)	113 (428)	96 (363)	130 (492)	96 (363)	96 (363)	147 (556)
Leaving Water Temperature (Min/Max), °F (°C) ³	40/60 (4.4/15.6)							
Maximum Water Side Pressure, psig (barg)	150 (10.3)							
Maximum Refrigerant Side Pressure, psig (barg)	235 (16.2)							
Evap Drain Connection, inches (mm)	3/4							

NOTES:

- Shipping and operating weights shown are for base unit; selected options may add weight to unit. Contact your nearest Johnson Controls Sales office for weight data.
- The evaporator is protected against freezing to 0°F(-17.8°C) with a standard heater.
- For leaving liquid temperature below 40°F(4.4°C) or above 60°F (15.6°C), contact your nearest Johnson Controls Sales Office for application requirements.

Evaporator Options

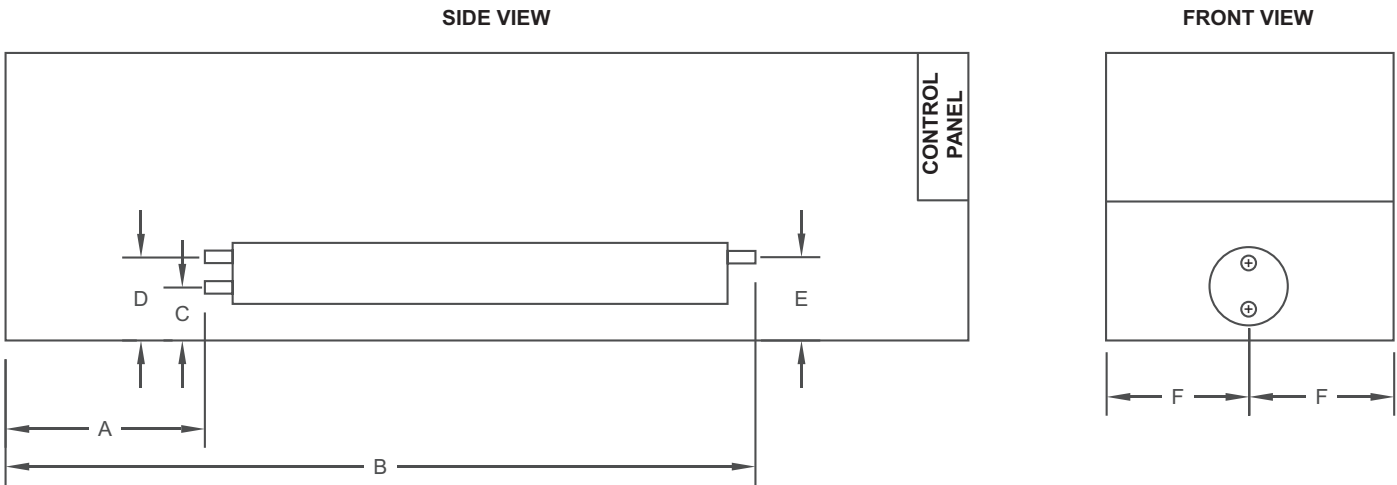

ENGLISH (SI) - ALL DIMENSIONS IN INCHES (mm)										
YVAA MODEL			STANDARD TWO-PASS, REAR INLET/OUTLET EVAPORATOR							
FRAME	COND.	EVAP.	A	C	D	F	C-606 CONN. SIZE	WATER VOL. GAL	MINIMUM CHILLED WATER FLOW RATE GPM (l/s)	MAXIMUM CHILLED WATER FLOW RATE GPM (l/s)
16	5	B	29.4 (745)	15.1 (384)	26.5 (674)	44.1 (1121)	6	58 (220)	250 (16)	950 (60)
17	8	C	34.9 (887)	15.1 (384)	26.5 (674)	44.1 (1121)	6	71 (269)	300 (19)	1150 (73)
18	3	A	17.7 (449)	14.1 (359)	25.5 (649)	44.1 (1121)	6	48 (182)	200 (13)	750 (47)
19	5	A	61.5 (1563)	14.1 (359)	25.5 (649)	44.1 (1121)	6	48 (182)	200 (13)	750 (47)
19	8	B	117.3 (2979)	15.3 (388)	26.7 (678)	44.1 (1121)	6	58 (220)	250 (16)	950 (60)
20	0	C	1.7 (43)	15.1 (384)	26.5 (674)	44.1 (1121)	6	71 (269)	300 (19)	1150 (73)
21	3	A	61.7 (1566)	14.1 (359)	25.5 (649)	44.1 (1121)	6	48 (182)	200 (13)	750 (47)
21	5	C	34.9 (887)	15.1 (384)	26.5 (674)	44.1 (1121)	6	71 (269)	300 (19)	1150 (73)
21	8	C	78.9 (2004)	15.3 (388)	26.7 (678)	44.1 (1121)	6	71 (269)	300 (19)	1150 (73)
23	3	B	73.3 (1862)	15.1 (384)	26.5 (674)	44.1 (1121)	6	58 (220)	250 (16)	950 (60)
24	5	C	92.9 (2359)	15.3 (388)	26.7 (678)	44.1 (1121)	6	71 (269)	300 (19)	1150 (73)
24	8	C	122.9 (3121)	15.3 (388)	26.7 (678)	44.1 (1121)	6	71 (269)	300 (19)	1150 (73)
26	3	B	117.3 (2979)	15.3 (388)	26.7 (678)	44.1 (1121)	6	58 (220)	250 (16)	950 (60)
27	3	D	42.9 (1090)	15.3 (388)	26.7 (678)	44.1 (1121)	6	82 (310)	300 (19)	1150 (73)
27	5	E	44.3 (1125)	15.5 (394)	29.5 (749)	44.1 (1121)	8	113 (428)	400 (25)	1500 (95)
27	8	E	88.3 (2242)	15.5 (394)	29.5 (749)	44.1 (1121)	8	113 (428)	400 (25)	1500 (95)
29	5	E	88.3 (2242)	15.5 (394)	29.5 (749)	44.1 (1121)	8	113 (428)	400 (25)	1500 (95)
30	3	C	122.9 (3121)	15.3 (388)	26.7 (678)	44.1 (1121)	6	71 (269)	300 (19)	1150 (73)
30	5	C	166.8 (4235)	15.1 (384)	26.5 (674)	44.1 (1121)	6	71 (269)	300 (19)	1150 (73)
30	8	E	132.2 (3359)	15.5 (394)	29.5 (749)	44.1 (1121)	8	113 (428)	400 (25)	1500 (95)

SIDE VIEW

FRONT VIEW

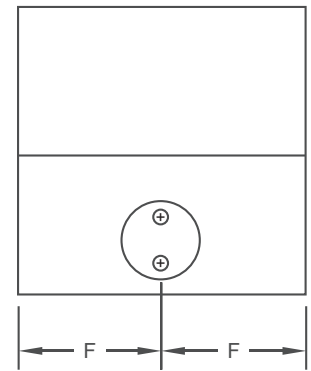
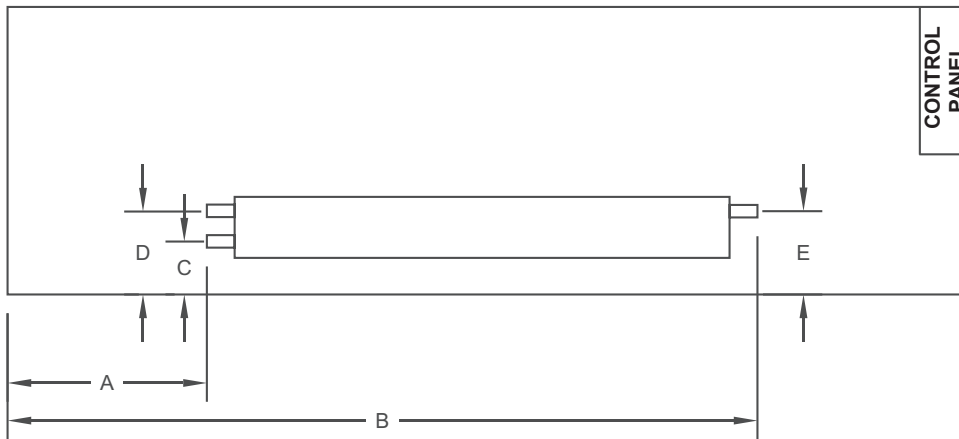

ENGLISH (SI) - ALL DIMENSIONS IN INCHES (mm)

YVAA MODEL			OPTIONAL THREE-PASS REAR INLET/FRONT OUTLET EVAPORATOR								
FRAME	COND.	EVAP.	A	B	C	E	F	C-606 CONN. SIZE	WATER VOL. GAL	MINIMUM CHILLED WATER FLOW RATE GPM (l/s)	MAXIMUM CHILLED WATER FLOW RATE GPM (l/s)
16	5	B	29.4 (745)	191.4 (4860)	15.1 (384)	26.5 (674)	44.1 (1121)	5	58 (220)	160 (10)	600 (38)
17	8	C	34.9 (887)	220.9 (5611)	15.1 (384)	26.5 (674)	44.1 (1121)	6	71 (269)	200 (13)	750 (47)
18	3	A	17.7 (449)	190.2 (4831)	14.1 (359)	25.5 (649)	44.1 (1121)	5	48 (182)	120 (8)	500 (32)
19	5	A	61.5 (1563)	234 (5945)	14.1 (359)	25.5 (649)	44.1 (1121)	5	48 (182)	120 (8)	500 (32)
19	8	B	117.3 (2979)	279.3 (7094)	15.3 (388)	26.7 (678)	44.1 (1121)	5	58 (220)	160 (10)	600 (38)
20	0	C	1.7 (43)	187.7 (4767)	15.1 (384)	26.5 (674)	44.1 (1121)	6	71 (269)	200 (13)	750 (47)
21	3	A	61.7 (1566)	234.2 (5948)	14.1 (359)	25.5 (649)	44.1 (1121)	5	48 (182)	120 (8)	500 (32)
21	5	C	34.9 (887)	220.9 (5611)	15.1 (384)	26.5 (674)	44.1 (1121)	6	71 (269)	200 (13)	750 (47)
21	8	C	78.9 (2004)	264.9 (6728)	15.3 (388)	26.7 (678)	44.1 (1121)	6	71 (269)	200 (13)	750 (47)
23	3	B	73.3 (1862)	235.3 (5977)	15.1 (384)	26.5 (674)	44.1 (1121)	5	58 (220)	160 (10)	600 (38)
24	5	C	92.9 (2359)	278.9 (7083)	15.3 (388)	26.7 (678)	44.1 (1121)	6	71 (269)	200 (13)	750 (47)
24	8	C	122.9 (3121)	308.9 (7845)	15.3 (388)	26.7 (678)	44.1 (1121)	6	71 (269)	200 (13)	750 (47)
26	3	B	117.3 (2979)	279.3 (7094)	15.3 (388)	26.7 (678)	44.1 (1121)	5	58 (220)	160 (10)	600 (38)
27	3	D	42.9 (1090)	264.9 (6729)	15.3 (388)	26.7 (678)	44.1 (1121)	6	82 (310)	200 (13)	750 (47)
27	5	E	44.3 (1125)	263.3 (6688)	15.5 (394)	29.5 (749)	44.1 (1121)	6	113 (428)	300 (19)	850 (54)
27	8	E	88.3 (2242)	307.3 (7805)	15.5 (394)	29.5 (749)	44.1 (1121)	6	113 (428)	300 (19)	850 (54)
29	5	E	88.3 (2242)	307.3 (7805)	15.5 (394)	29.5 (749)	44.1 (1121)	6	113 (428)	300 (19)	850 (54)
30	3	C	122.9 (3121)	308.9 (7845)	15.3 (388)	26.7 (678)	44.1 (1121)	6	71 (269)	200 (13)	750 (47)
30	5	C	166.8 (4235)	352.8 (8959)	15.1 (384)	26.5 (674)	44.1 (1121)	6	71 (269)	200 (13)	750 (47)
30	8	E	132.2 (3359)	351.2 (8922)	15.5 (394)	29.5 (749)	44.1 (1121)	6	113 (428)	300 (19)	850 (54)

SIDE VIEW

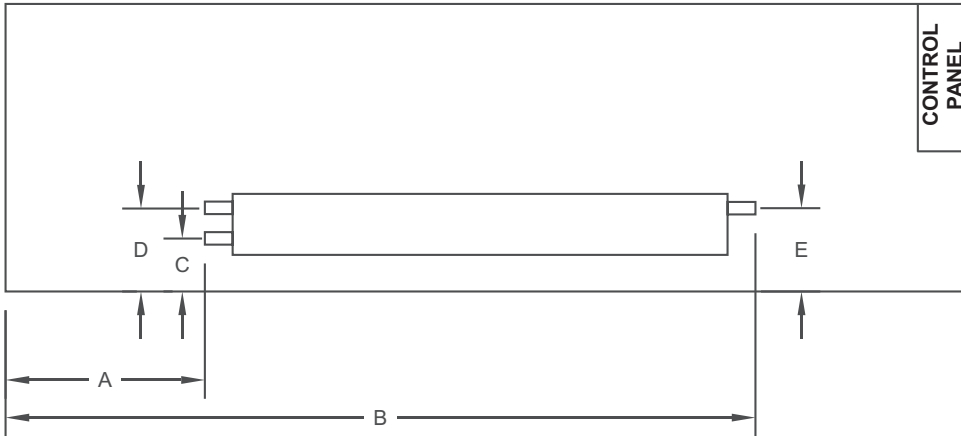

FRONT VIEW

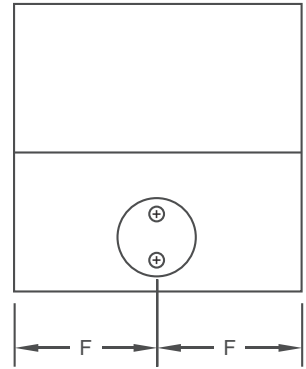

ENGLISH (SI) - ALL DIMENSIONS IN INCHES (mm)

YVAA MODEL			STANDARD TWO-PASS, REAR INLET/OUTLET EVAPORATOR							
FRAME	COND.	EVAP.	A	C	D	F	C-606 CONN. SIZE	WATER VOL. GAL	MINIMUM CHILLED WATER FLOW RATE GPM (l/s)	MAXIMUM CHILLED WATER FLOW RATE GPM (l/s)
31	8	E	176.2 (4476)	15.5 (394)	29.5 (749)	44.1 (1121)	8	113 (428)	400 (25)	1500 (95)
32	3	E	88.3 (2242)	15.5 (394)	29.5 (749)	44.1 (1121)	8	113 (428)	400 (25)	1500 (95)
33	3	C	166.9 (4238)	15.3 (388)	26.7 (678)	44.1 (1121)	6	71 (269)	300 (19)	1150 (73)
34	3	E	132.2 (3359)	15.5 (394)	29.5 (749)	44.1 (1121)	8	113 (428)	400 (25)	1500 (95)
34	5	E	176.2 (4476)	15.5 (394)	29.5 (749)	44.1 (1121)	8	113 (428)	400 (25)	1500 (95)
36	8	J	209 (5309)	15.5 (394)	29.5 (749)	44.1 (1121)	8	147 (556)	550 (35)	1880 (119)
37	3	F	180.9 (4595)	15.8 (402)	28.8 (732)	44.2 (1122)	8	96 (363)	460 (29)	1540 (97)
37	5	J	164.4 (4176)	16.3 (414)	30.3 (769)	44.1 (1121)	8	147 (556)	550 (35)	1880 (119)
39	8	J	252.5 (6414)	16.3 (414)	30.3 (769)	44.1 (1121)	8	147 (556)	550 (35)	1880 (119)
41	3	H	164.6 (4180)	15.5 (394)	29.47 (749)	44.2 (1122)	8	130 (492)	520 (33)	1700 (107)
42	5	H	252.6 (6416)	15.5 (394)	29.5 (749)	44.1 (1121)	8	130 (492)	520 (33)	1700 (107)
42	8	J	295.5 (7506)	16.3 (414)	30.3 (769)	44.1 (1121)	8	147 (556)	550 (35)	1880 (119)
44	3	G	287.1 (7292)	15.8 (402)	28.8 (732)	44.2 (1122)	8	96 (363)	460 (29)	1540 (97)
47	5	J	309.1 (7852)	16.3 (414)	30.3 (769)	44.2 (1122)	8	147 (556)	550 (35)	1880 (119)
48	3	G	331 (8409)	15.8 (402)	28.8 (732)	44.2 (1122)	8	96 (363)	460 (29)	1540 (97)
50	0	J	177 (4495)	16.3 (414)	30.3 (769)	44.2 (1122)	8	147 (556)	550 (35)	1880 (119)
52	3	J	309.1 (7852)	16.3 (414)	30.3 (769)	44.2 (1122)	8	147 (556)	550 (35)	1880 (119)

SIDE VIEW

FRONT VIEW

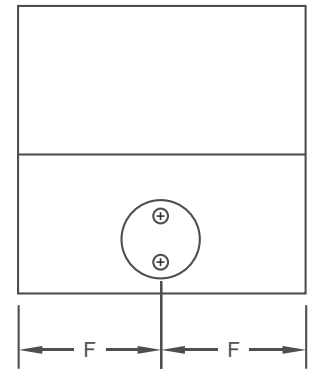
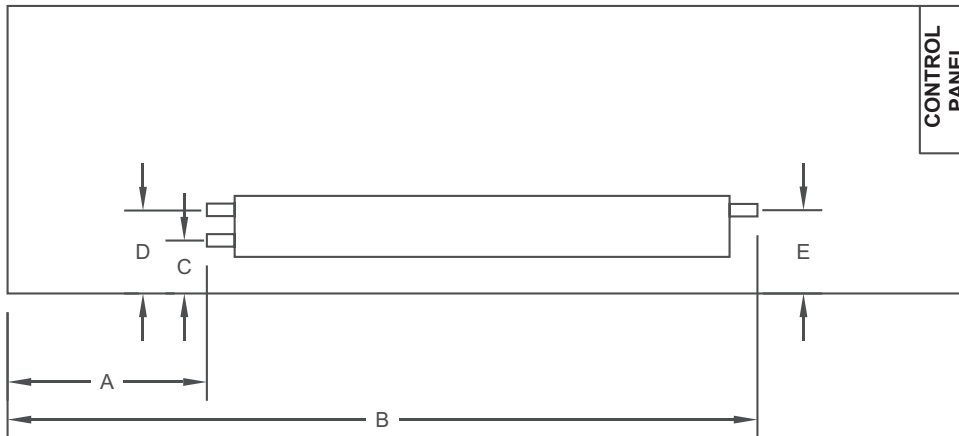

ENGLISH (SI) - ALL DIMENSIONS IN INCHES (mm)

YVAA MODEL			OPTIONAL THREE-PASS REAR INLET/FRONT OUTLET EVAPORATOR								
FRAME	COND.	EVAP.	A	B	C	E	F	C-606 CONN. SIZE	WATER VOL. GAL	MINIMUM CHILLED WATER FLOW RATE GPM (l/s)	MAXIMUM CHILLED WATER FLOW RATE GPM (l/s)
31	8	E	176.2 (4476)	395.2 (10039)	15.5 (394)	29.5 (749)	44.1 (1121)	6	113 (428)	300 (19)	850 (54)
32	3	E	88.3 (2242)	307.3 (7805)	15.5 (394)	29.5 (749)	44.1 (1121)	6	113 (428)	300 (19)	850 (54)
33	3	C	166.9 (4238)	352.9 (8962)	15.3 (388)	26.7 (678)	44.1 (1121)	6	71 (269)	200 (13)	750 (47)
34	3	E	132.2 (3359)	351.2 (8922)	15.5 (394)	29.5 (749)	44.1 (1121)	6	113 (428)	300 (19)	850 (54)
34	5	E	176.2 (4476)	395.2 (10039)	15.5 (394)	29.5 (749)	44.1 (1121)	6	113 (428)	300 (19)	850 (54)
36	8	J	209 (5309)	427.8 (10866)	15.5 (394)	29.5 (749)	44.1 (1121)	8	147 (556)	350 (25)	1400 (88)
37	3	F	180.9 (4595)	354.9 (9015)	15.8 (402)	44.2 (1122)	44.2 (1122)	6	94 (356)	310 (20)	1070 (68)
37	5	J	164.4 (4176)	383.7 (9746)	16.3 (414)	30.3 (769)	44.1 (1121)	8	147 (556)	400 (25)	1400 (88)
39	8	J	252.5 (6414)	471.5 (11976)	16.3 (414)	30.3 (769)	44.1 (1121)	8	147 (556)	400 (25)	1400 (88)
41	3	H	164.6 (4180)	383.3 (9737)	15.5 (394)	44.2 (1122)	44.2 (1122)	6	128 (485)	350 (22)	1200 (76)
42	5	H	252.6 (6416)	471.5 (11976)	15.5 (394)	29.5 (749)	44.1 (1121)	6	128 (485)	350 (22)	1200 (76)
42	8	J	295.5 (7506)	515.4 (13091)	16.3 (414)	30.3 (769)	44.1 (1121)	8	147 (556)	400 (25)	1400 (88)
44	3	G	287.1 (7292)	461.1 (11712)	15.8 (402)	44.2 (1122)	44.2 (1122)	6	94 (356)	310 (20)	1070 (68)
47	5	J	309.1 (7852)	528.3 (13421)	16.3 (414)	16.3 (769)	44.1 (1122)	8	147 (556)	400 (25)	1400 (88)
48	3	G	331 (8409)	505.1 (12829)	15.8 (402)	44.2 (1122)	44.2 (1122)	6	94 (356)	310 (20)	1070 (68)
50	0	J	177 (4495)	396.2 (10064)	16.3 (414)	16.3 (769)	44.2 (1122)	8	147 (556)	400 (25)	1400 (88)
52	3	J	309.1 (7852)	528.3 (13421)	16.3 (414)	16.3 (769)	44.2 (1122)	8	147 (556)	400 (25)	1400 (88)

Dimensions

The data shown in this figure is applicable to selected typical configurations. Other configurations are available through our configuration/selection software. Please contact your nearest Johnson Controls Sales Office for the chiller configuration that best matches your specific needs.

ENGLISH AND SI DIMENSIONS

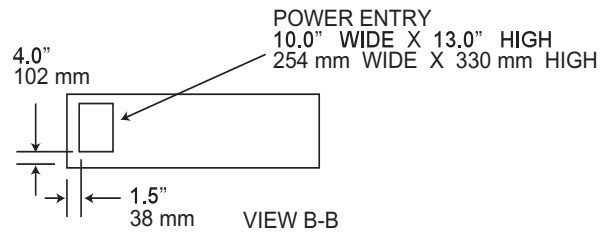
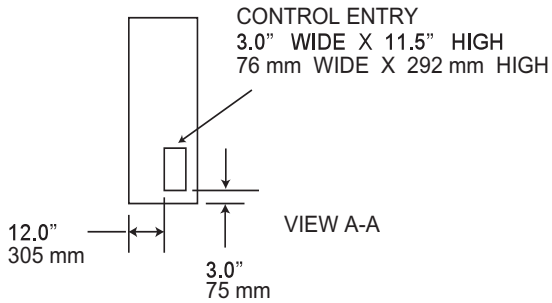
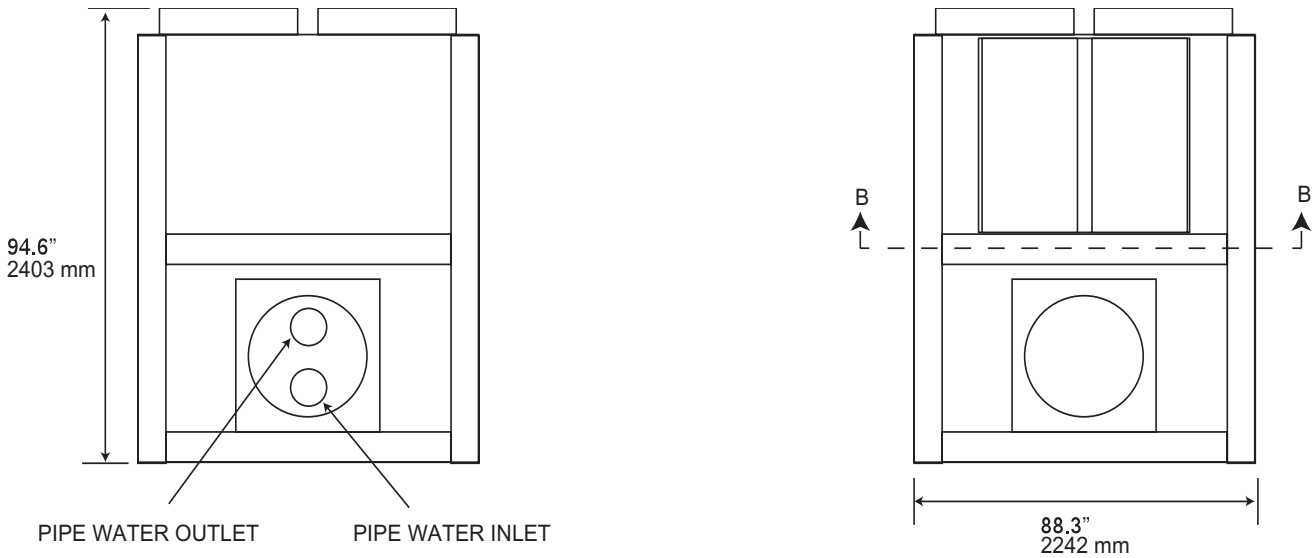

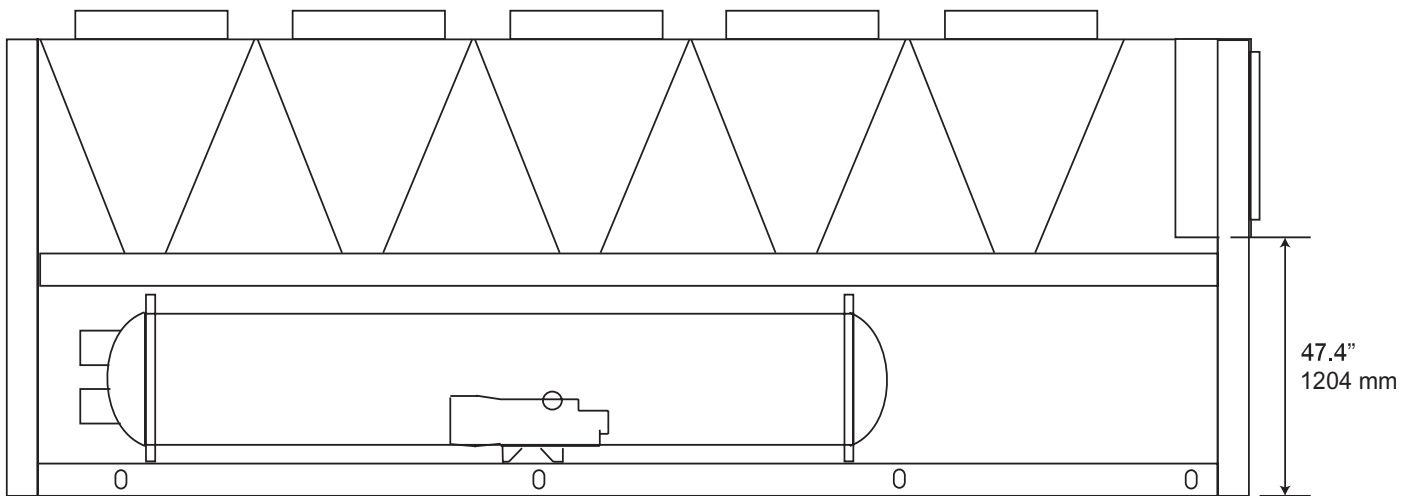
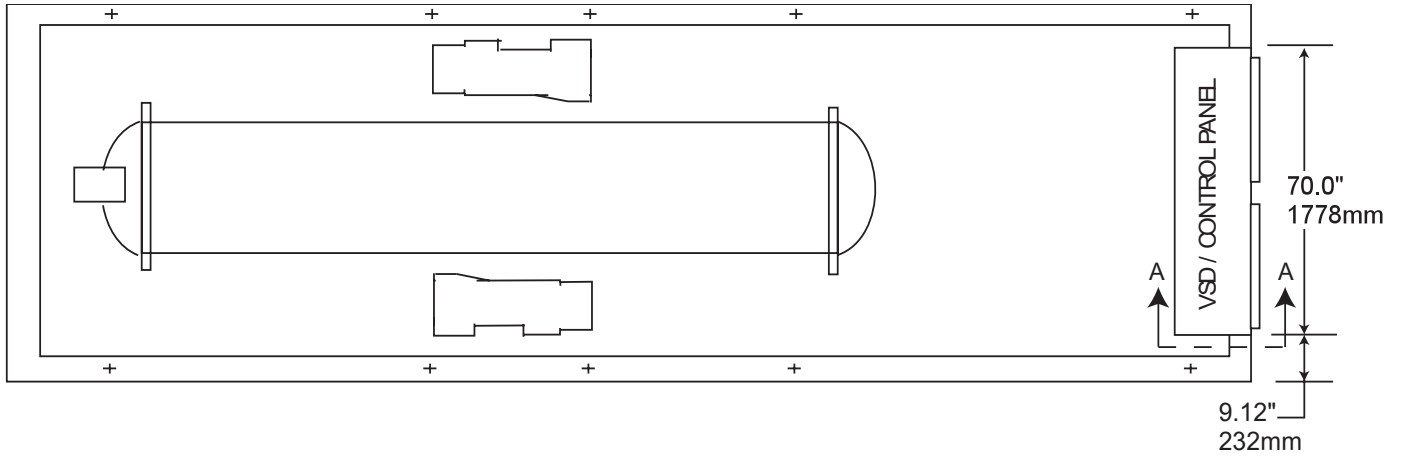

Rigging Hole Locations

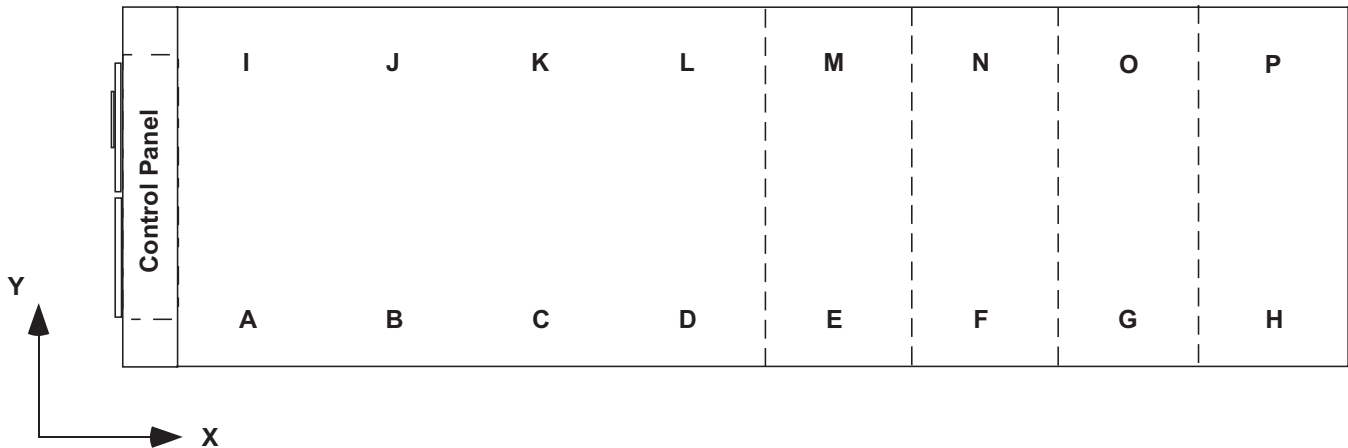

YVAA MODEL			DESCRIPTION	A	B	C	D	E	F	G	H	I	J	K	L	M	N	O	P	CENTER OF GRAVITY		
FRAME	COND	EVAP																		X (IN)	Y (IN)	
015	3	B	Rigging Hole Location inches (mm)	18 (464)	60 (1512)	116 (2937)	192 (4866)					18 (464)	60 (1511)	116 (2937)	192 (4866)						102 (2578)	44 (1122)
			Point Load inches (kgs)	1035 (470)	1676 (760)	1676 (760)	1372 (622)							951 (431)	1656 (751)	1656 (751)	1495 (678)					
016	5	B	Rigging Hole Location inches (mm)	18 (464)	60 (1533)	137 (3485)	214 (5435)					18 (464)	60 (1533)	137 (3485)	214 (5435)						126 (3206)	44 (1122)
			Point Load inches (kgs)	624 (283)	1139 (516)	3081 (1397)	1198 (543)							606 (275)	1120 (508)	3057 (1387)	1259 (571)					
017	8	C	Rigging Hole Location inches (mm)	12 (314)	73 (1845)	144 (3654)	197 (5012)	260 (6593)					12 (314)	73 (1845)	144 (3654)	197 (5012)	260 (6593)				144 (3649)	44 (1122)
			Point Load inches (kgs)	625 (283)	1746 (792)	2573 (1167)	1287 (584)	1103 (501)						634 (288)	1612 (731)	2611 (1184)	1305 (592)	1172 (532)				
018	3	A	Rigging Hole Location inches (mm)	18 (464)	60 (1533)	143 (3636)	220 (5598)					18 (464)	60 (1533)	143 (3636)	220 (5598)						128 (3248)	44 (1122)
			Point Load inches (kgs)	504 (229)	1448 (657)	2890 (1311)	1142 (518)							510 (231)	1416 (642)	2917 (1323)	1192 (541)					
019	5	A	Rigging Hole Location inches (mm)	18 (464)	60 (1533)	143 (3636)	227 (5761)	272 (6920)				18 (464)	60 (1533)	143 (3636)	227 (5761)	272 (6920)					139 (3523)	44 (1122)
			Point Load inches (kgs)	469 (213)	1474 (669)	2778 (1260)	1389 (630)	256 (116)						484 (219)	1422 (645)	2831 (1284)	1416 (642)	264 (120)				
019	8	B	Rigging Hole Location inches (mm)	18 (464)	60 (1533)	137 (3484)	215 (5455)	302 (7670)				18 (464)	60 (1533)	137 (3484)	215 (5455)	302 (7670)					148 (3760)	44 (1122)
			Point Load inches (kgs)	416 (189)	1628 (738)	2445 (1109)	1657 (751)	717 (325)						396 (180)	1631 (740)	2453 (1113)	1716 (779)	717 (325)				
021	3	A	Rigging Hole Location inches (mm)	18 (464)	60 (1533)	143 (3637)	227 (5761)	272 (6920)				18 (464)	60 (1533)	143 (3637)	227 (5761)	272 (6920)					139 (3530)	44 (1122)
			Point Load inches (kgs)	472 (214)	1467 (665)	2822 (1280)	1411 (640)	257 (117)						484 (220)	1419 (644)	2841 (1288)	1420 (644)	264 (120)				
021	5	C	Rigging Hole Location inches (mm)	12 (314)	73 (1845)	144 (3654)	197 (5012)	260 (6593)				12 (314)	73 (1845)	144 (3654)	197 (5012)	260 (6593)					150 (3806)	44 (1122)
			Point Load inches (kgs)	480 (218)	1988 (902)	1988 (902)	1688 (766)	1314 (596)						472 (214)	1935 (878)	1935 (878)	1736 (788)	1379 (626)				
021	8	C	Rigging Hole Location inches (mm)	12 (314)	73 (1845)	163 (4144)	254 (6443)	324 (8218)				12 (314)	73 (1845)	163 (4144)	254 (6443)	324 (8218)					153 (3889)	44 (1122)
			Point Load inches (kgs)	518 (235)	2344 (1063)	3047 (1382)	1501 (681)	428 (194)						510 (231)	2282 (1035)	2967 (1346)	1743 (791)	336 (152)				

Weights are based upon microchannel coil units.

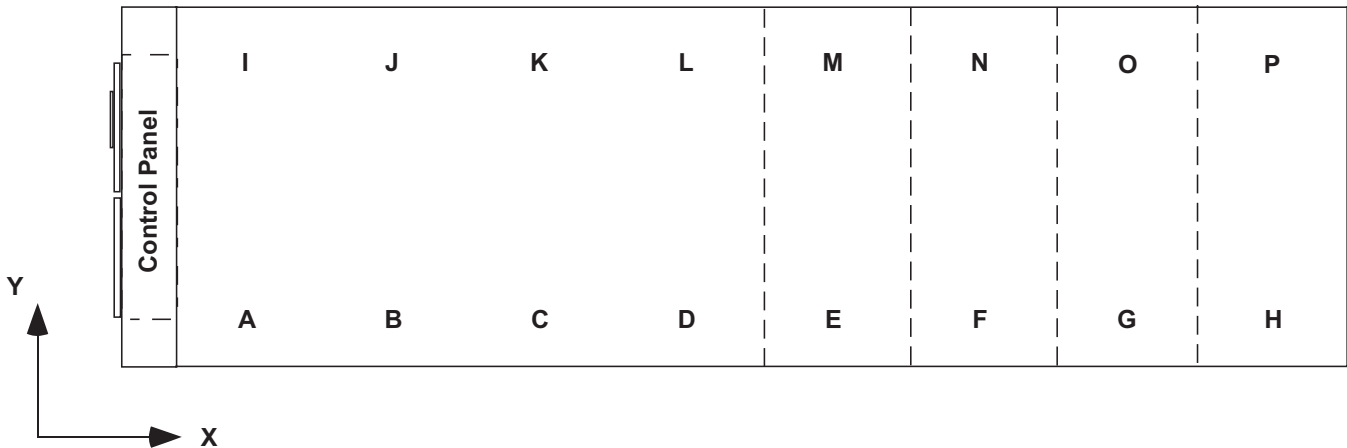

YVAA MODEL			DESCRIPTION	A	B	C	D	E	F	G	H	I	J	K	L	M	N	O	P	CENTER OF GRAVITY			
FRAME	COND	EVAP																		X (IN)	Y (IN)		
023	3	B	Rigging Hole Location inches (mm)	18 (464)	60 (1533)	137 (3485)	215 (5456)	272 (6919)				18 (464)	60 (1533)	137 (3485)	215 (5456)	272 (6919)					135 (3418)	44 (1122)	
			Point Load inches (kgs)	340 (154)	2054 (932)	2049 (929)	2049 (929)	143 (65)						329 (149)	2038 (925)	2067 (938)	2067 (938)	151 (69)					
024	5	C	Rigging Hole Location inches (mm)	18 (464)	60 (1533)	149 (3789)	240 (6088)	324 (8218)				18 (464)	60 (1533)	149 (3789)	240 (6088)	324 (8218)						152 (3851)	44 (1122)
			Point Load inches (kgs)	358 (162)	2130 (966)	2982 (1352)	2151 (975)	307 (139)					354 (160)	2079 (943)	2911 (1320)	2340 (1061)	261 (118)						
024	8	C	Rigging Hole Location inches (mm)	12 (314)	73 (1845)	163 (4144)	254 (6443)	347 (8825)				12 (314)	73 (1845)	163 (4144)	254 (6443)	347 (8825)						169 (4289)	44 (1122)
			Point Load inches (kgs)	697 (316)	1921 (871)	3078 (1396)	1741 (790)	871 (395)					697 (316)	1800 (817)	3169 (1437)	1773 (804)	886 (402)						
026	3	B	Rigging Hole Location inches (mm)	18 (464)	60 (1533)	137 (3484)	215 (5455)	302 (7670)				18 (464)	60 (1533)	137 (3484)	215 (5455)	302 (7670)						146 (3721)	44 (1122)
			Point Load inches (kgs)	513 (233)	1610 (730)	2517 (1142)	1681 (763)	717 (325)					490 (222)	1620 (735)	2489 (1129)	1722 (781)	717 (325)						
027	3	D	Rigging Hole Location inches (mm)	12 (314)	73 (1845)	121 (3073)	181 (4601)	264 (6717)	324 (8217)			12 (314)	73 (1845)	121 (3073)	181 (4601)	264 (6717)	324 (8217)					168 (4259)	44 (1122)
			Point Load inches (kgs)	877 (398)	553 (251)	1442 (654)	3605 (1635)	1108 (502)	554 (251)				808 (366)	570 (259)	1411 (640)	3527 (1600)	1214 (551)	607 (275)					
027	5	E	Rigging Hole Location inches (mm)	12 (314)	73 (1845)	121 (3073)	181 (4601)	264 (6717)	324 (8218)			12 (314)	73 (1845)	121 (3073)	181 (4601)	264 (6717)	324 (8218)					168 (4274)	44 (1122)
			Point Load inches (kgs)	872 (396)	569 (258)	1524 (691)	3811 (1729)	1146 (520)	573 (260)				803 (364)	587 (266)	1493 (677)	3734 (1694)	1252 (568)	626 (284)					
027	8	E	Rigging Hole Location inches (mm)	12 (314)	73 (1845)	121 (3073)	181 (4601)	243 (6169)	347 (8825)			12 (314)	73 (1845)	121 (3073)	181 (4601)	243 (6169)	347 (8825)					178 (4525)	44 (1122)
			Point Load inches (kgs)	616 (280)	1372 (622)	1138 (516)	2845 (1290)	1937 (878)	968 (439)				542 (246)	1407 (638)	1099 (498)	2747 (1246)	2054 (932)	1027 (466)					
029	5	E	Rigging Hole Location inches (mm)	12 (314)	73 (1845)	179 (4551)	290 (7358)	347 (8825)				12 (314)	73 (1845)	179 (4551)	290 (7358)	347 (8825)						177 (4495)	44 (1122)
			Point Load inches (kgs)	500 (227)	1930 (875)	4518 (2049)	1506 (683)	533 (242)					434 (197)	1937 (879)	4698 (2131)	1566 (710)	583 (264)						
030	3	C	Rigging Hole Location inches (mm)	12 (314)	73 (1845)	161 (4092)	254 (6443)	347 (8825)				12 (314)	73 (1845)	161 (4092)	254 (6443)	347 (8825)						168 (4256)	44 (1122)
			Point Load inches (kgs)	747 (339)	1875 (850)	3196 (1450)	1749 (793)	874 (397)					747 (339)	1784 (809)	3464 (1571)	1785 (810)	893 (405)						

Weights are based upon microchannel coil units.

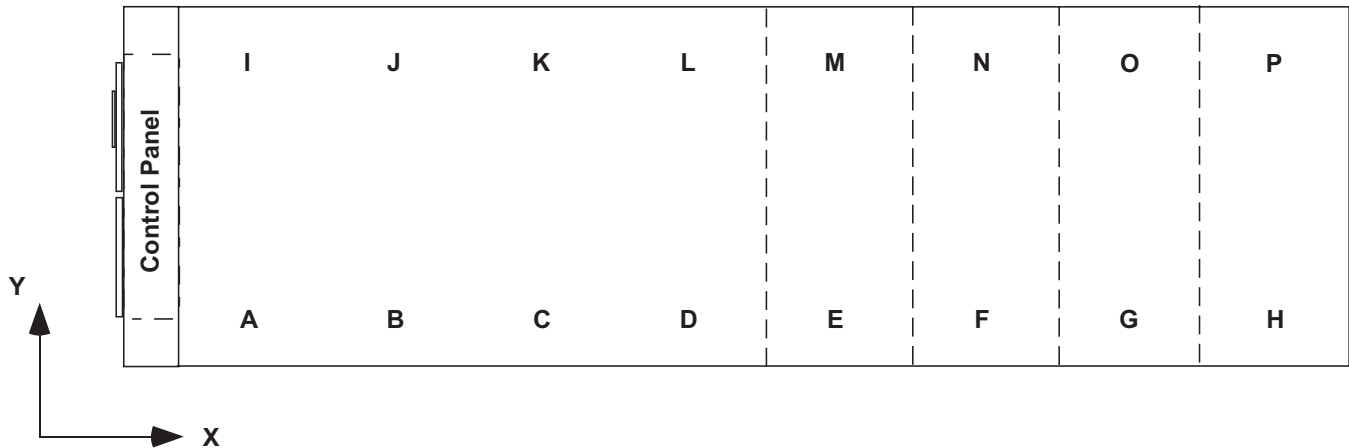

YVAA MODEL			DESCRIPTION	A	B	C	D	E	F	G	H	I	J	K	L	M	N	O	P	CENTER OF GRAVITY		
FRAME	COND	EVAP																		X (IN)	Y (IN)	
030	5	C	Rigging Hole Location inches (mm)	12 (314)	73 (1845)	161 (4092)	254 (6443)	306 (7763)	391 (9941)			12 (314)	73 (1845)	161 (4092)	254 (6443)	306 (7763)	391 (9941)				180 (4566)	44 (1122)
			Point Load inches (kgs)	559 (253)	2024 (918)	3021 (1370)	2164 (981)	302 (137)	752 (341)				411 (187)	2226 (1010)	2990 (1356)	2374 (1077)	299 (136)	752 (341)				
030	8	E	Rigging Hole Location inches (mm)	12 (314)	73 (1845)	121 (3072)	179 (4549)	243 (6169)	296 (7508)	391 (9942)			12 (314)	73 (1845)	121 (3072)	179 (4549)	243 (6169)	296 (7508)	391 (9942)		204 (5172)	44 (1122)
			Point Load inches (kgs)	1113 (505)	323 (147)	2182 (990)	2182 (990)	1309 (594)	1505 (683)	753 (341)			1073 (487)	398 (180)	2162 (981)	2162 (981)	1547 (702)	1505 (683)	753 (341)			
031	8	E	Rigging Hole Location inches (mm)	12 (314)	73 (1845)	121 (3072)	179 (4549)	243 (6169)	353 (8962)	435 (11059)			12 (314)	73 (1845)	121 (3072)	179 (4549)	243 (6169)	353 (8962)	435 (11059)		210 (5341)	44 (1122)
			Point Load inches (kgs)	1028 (466)	575 (261)	2009 (911)	2009 (911)	1309 (594)	1580 (717)	527 (239)			988 (448)	650 (295)	1988 (902)	1988 (902)	2259 (1025)	1580 (717)	527 (239)			
032	3	E	Rigging Hole Location inches (mm)	12 (314)	73 (1845)	121 (3073)	181 (4601)	243 (6169)	347 (8825)				12 (314)	73 (1845)	121 (3073)	181 (4601)	243 (6169)	347 (8825)			177 (4504)	44 (1122)
			Point Load inches (kgs)	701 (318)	1261 (572)	1250 (567)	3125 (1417)	1960 (889)	980 (445)				604 (274)	1370 (622)	1204 (546)	3010 (1365)	2060 (934)	1030 (467)				
033	3	C	Rigging Hole Location inches (mm)	12 (314)	73 (1845)	163 (4144)	254 (6443)	306 (7765)	391 (9942)				12 (314)	73 (1845)	163 (4144)	254 (6443)	306 (7765)	391 (9942)			180 (4563)	44 (1122)
			Point Load inches (kgs)	550 (250)	2052 (931)	3327 (1509)	2098 (952)	333 (151)	752 (341)				373 (169)	2354 (1068)	2951 (1338)	2387 (1083)	295 (134)	752 (341)				
034	3	E	Rigging Hole Location inches (mm)	12 (314)	73 (1845)	121 (3073)	181 (4602)	243 (6170)	296 (7511)	391 (9942)			12 (314)	73 (1845)	121 (3073)	181 (4602)	243 (6170)	296 (7511)	391 (9942)		204 (5172)	44 (1122)
			Point Load inches (kgs)	1087 (493)	408 (185)	2224 (1009)	2224 (1009)	1456 (660)	1505 (683)	753 (341)			1038 (471)	514 (233)	2135 (968)	2135 (968)	1578 (716)	1505 (683)	753 (341)			
034	5	E	Rigging Hole Location inches (mm)	12 (314)	73 (1845)	121 (3073)	181 (4602)	243 (6170)	353 (8961)	435 (11059)			12 (314)	73 (1845)	121 (3073)	181 (4602)	243 (6170)	353 (8961)	435 (11059)		210 (5338)	44 (1122)
			Point Load inches (kgs)	1002 (455)	659 (299)	2048 (929)	2048 (929)	2173 (986)	1580 (717)	527 (239)			953 (432)	765 (347)	1959 (889)	1959 (889)	2295 (1041)	1580 (717)	527 (239)			
36	8	J	Rigging Hole Location inches (mm)	12 (314)	73 (1845)	181 (4602)	238 (6039)	302 (7662)	392 (9957)	434 (11024)	501 (12725)		12 (314)	73 (1845)	181 (4602)	238 (6039)	302 (7662)	392 (9957)	434 (11024)	501 (12725)	208 (5283)	46 (1168)
			Point Load inches (kgs)	142 (64)	2884 (1308)	4376 (1985)	929 (421)	1857 (842)	697 (316)	310 (141)	520 (236)	130 (59)	2825 (1281)	5741 (2604)	935 (424)	1871 (849)	827 (375)	312 (141)	475 (215)			
037	3	F	Rigging Hole Location inches (mm)	12 (314)	73 (1845)	181 (4602)	238 (6039)	302 (7662)	435 (11059)				12 (314)	73 (1845)	181 (4602)	238 (6039)	302 (7662)	435 (11059)			210 (5334)	49 (1245)
			Point Load inches (kgs)	396 (179)	2152 (976)	4507 (2044)	396 (179)	2142 (972)	881 (400)				368 (167)	2116 (960)	5853 (2655)	368 (167)	2287 (1037)	881 (400)				
37	5	J	Rigging Hole Location inches (mm)	12 (314)	73 (1845)	181 (4602)	238 (6039)	302 (7662)	435 (11059)				12 (314)	73 (1845)	181 (4602)	238 (6039)	302 (7662)	435 (11059)			198 (5029)	46 (1168)
			Point Load inches (kgs)	268 (131)	2654 (1024)	4794 (2175)	288 (131)	2430 (1102)	881 (400)				268 (122)	2613 (1185)	6131 (2781)	268 (122)	2574 (1168)	881 (400)				

Weights are based upon microchannel coil units.

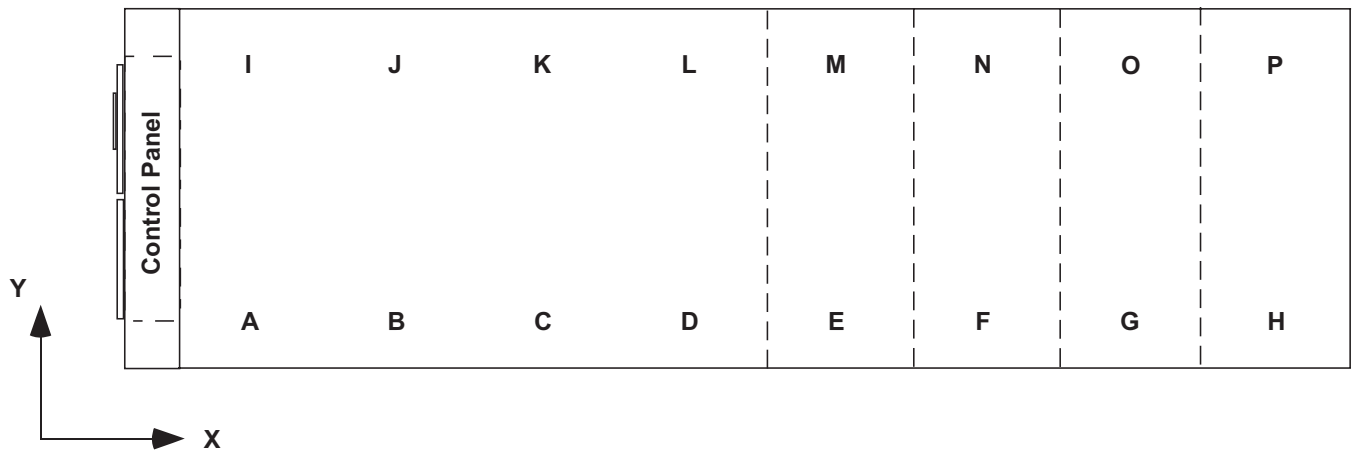

YVAA MODEL			DESCRIPTION	A	B	C	D	E	F	G	H	I	J	K	L	M	N	O	P	CENTER OF GRAVITY	
FRAME	COND	EVAP																		X (IN)	Y (IN)
39	8	J	Rigging Hole Location inches (mm)	12 (314)	73 (1845)	181 (4602)	238 (6039)	302 (7358)	435 (11059)	478 (12135)	545 (13835)	12 (314)	73 (1845)	181 (4602)	238 (6039)	302 (7358)	435 (11059)	478 (12135)	545 (13835)	218 (5537)	46 (1168)
			Point Load inches (kgs)	101 (47)	2865 (1300)	4576 (2076)	1068 (484)	2019 (916)	72 (33)	169 (77)	1517 (688)	108 (49)	2759 (1251)	5815 (2638)	980 (445)	2153 (977)	70 (32)	167 (76)	1504 (682)		
041	3	H	Rigging Hole Location inches (mm)	12 (314)	73 (1845)	181 (4601)	238 (6039)	302 (7662)	435 (11059)			12 (314)	73 (1845)	181 (4601)	238 (6039)	302 (7662)	435 (11059)			219 (5563)	48 (1219)
			Point Load inches (kgs)	423 (192)	2025 (918)	4375 (1984)	423 (192)	1910 (867)	881 (400)			406 (184)	1977 (897)	5529 (2508)	406 (184)	2008 (911)	881 (400)				
42	5	H	Rigging Hole Location inches (mm)	12 (314)	73 (1845)	181 (4602)	238 (6039)	302 (7358)	435 (11059)	478 (12135)	545 (13835)	12 (314)	73 (1845)	181 (4602)	238 (6039)	302 (7358)	435 (11059)	478 (12135)	545 (13835)	222 (5639)	46 (1168)
			Point Load inches (kgs)	85 (39)	2831 (1284)	3122 (1416)	1273 (577)	1707 (774)	74 (34)	172 (78)	1534 (696)	92 (42)	2725 (1236)	4362 (1979)	1185 (538)	1841 (835)	72 (33)	170 (77)	1520 (689)		
42	8	J	Rigging Hole Location inches (mm)	12 (314)	73 (1845)	181 (4602)	238 (6039)	302 (7358)	435 (11059)	494 (12546)	572 (14541)	12 (314)	73 (1845)	181 (4602)	238 (6039)	302 (7358)	435 (11059)	494 (12546)	572 (14541)	227 (5766)	46 (1168)
			Point Load inches (kgs)	204 (93)	2793 (1267)	5125 (2325)	71 (32)	2514 (1140)	454 (206)	1056 (479)	551 (250)	198 (90)	2927 (1328)	5792 (2627)	323 (147)	2635 (1195)	454 (206)	1056 (479)	551 (250)		
044	3	G	Rigging Hole Location inches (mm)	12 (314)	73 (1845)	181 (4602)	238 (6039)	290 (7662)	435 (11059)	478 (12135)	545 (13835)	12 (314)	73 (1845)	181 (4602)	238 (6039)	290 (7358)	435 (11059)	478 (12135)	545 (13835)	227 (5766)	46 (1168)
			Point Load inches (kgs)	189 (86)	2952 (1339)	5346 (2425)	608 (276)	2066 (937)	77 (35)	176 (80)	1557 (706)	119 (54)	3024 (1372)	5101 (2314)	796 (361)	2117 (960)	78 (35)	176 (80)	1561 (708)		
47	5	J	Rigging Hole Location inches (mm)	12 (314)	73 (1845)	181 (4602)	238 (6039)	290 (7358)	435 (11059)	494 (12546)	572 (14541)	12 (314)	73 (1845)	181 (4602)	238 (6039)	290 (7358)	435 (11059)	494 (12546)	572 (14541)	234 (5944)	46 (1168)
			Point Load inches (kgs)	335 (152)	3102 (1407)	5541 (2513)	318 (144)	2792 (1266)	518 (235)	1055 (479)	551 (250)	263 (119)	3176 (1441)	5295 (2402)	496 (225)	2858 (1296)	518 (235)	1055 (479)	551 (250)		
048	3	G	Rigging Hole Location inches (mm)	12 (314)	73 (1845)	181 (4602)	238 (6039)	290 (7358)	435 (11059)	494 (12546)	572 (14529)	12 (305)	73 (1854)	181 (4597)	238 (6045)	290 (7366)	435 (11049)			234 (5944)	46 (1168)
			Point Load inches (kgs)	338 (153)	2564 (1163)	5914 (2683)	104 (47)	2308 (1047)	518 (235)	1055 (479)	551 (250)	270 (122)	2630 (1193)	5677 (2575)	282 (128)	2367 (1074)	518 (235)	1055 (479)	551 (250)		
052	3	J	Rigging Hole Location inches (mm)	12 (305)	73 (1854)	181 (4597)	238 (6045)	290 (7366)	435 (11049)	494 (12548)	572 (14529)	12 (305)	73 (1854)	181 (4597)	238 (6045)	290 (7366)	435 (11049)	494 (12548)	572 (14529)	234 (5944)	46 (1168)
			Point Load inches (kgs)	335 (152)	3102 (1407)	5541 (2513)	318 (144)	2792 (1266)	518 (235)	1055 (478)	551 (250)	263 (119)	3176 (1441)	5295 (2402)	496 (225)	2858 (1296)	518 (235)	1055 (478)	551 (250)		

Weights are based upon microchannel coil units.

Isolator Locations

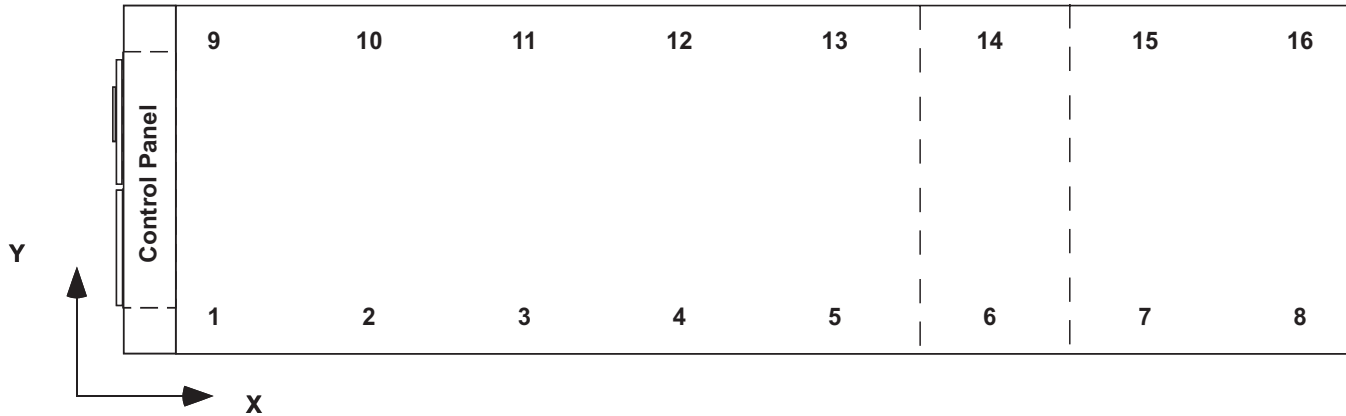

YVAA MODEL			DESCRIPTION	1	2	3	4	5	6	7	8	9	10	11	12	13	14	15	16	
FRAME	COND	EVAP		1	2	3	4	5	6	7	8	9	10	11	12	13	14	15	16	
15	3	B	Isolator X-Dimension inches (mm)	10 (263)	73 (1852)	144 (3662)	193 (4900)					10 (263)	73 (1852)	144 (3662)	193 (4900)					
			Isolator Y-Dimension inches (mm)	1 (34)								87 (2206)								
			Point Load lbs (kgs)	1055 (479)	2150 (975)	2150 (975)	635 (288)							981 (445)	2119 (961)	2119 (961)	771 (350)			
16	5	B	Isolator X-Dimension inches (mm)	10 (263)	77 (1943)	118 (3000)	157 (3985)	220 (5589)					10 (263)	77 (1943)	118 (3000)	157 (3985)	220 (5589)			
			Isolator Y-Dimension inches (mm)	1 (34)								87 (2206)								
			Point Load lbs (kgs)	883 (401)	764 (347)	1788 (811)	1788 (811)	1048 (475)						865 (392)	736 (334)	1786 (810)	1786 (810)	1100 (499)		
17	8	C	Isolator X-Dimension inches (mm)	10 (263)	81 (2057)	149 (3779)	187 (4756)	251 (6368)					10 (263)	81 (2057)	149 (3779)	187 (4756)	251 (6368)			
			Isolator Y-Dimension inches (mm)	1 (34)								87 (2206)								
			Point Load lbs (kgs)	734 (333)	2308 (1047)	1598 (725)	1598 (725)	1477 (670)						726 (329)	2201 (998)	1616 (733)	1616 (733)	1557 (706)		
18	3	A	Isolator X-Dimension inches (mm)	10 (263)	76 (1943)	124 (3152)	163 (4137)	210 (5323)					10 (263)	76 (1943)	124 (3152)	163 (4137)	210 (5323)			
			Isolator Y-Dimension inches (mm)	1 (34)								87 (2206)								
			Point Load lbs (kgs)	714 (324)	1658 (752)	1089 (494)	1089 (494)	1655 (751)						708 (321)	1652 (749)	1085 (492)	1085 (492)	1725 (782)		
19	5	A	Isolator X-Dimension inches (mm)	10 (259)	76 (1939)	118 (2997)	157 (3982)	208 (5295)	281 (7132)					10 (259)	76 (1939)	118 (2997)	157 (3982)	208 (5295)	281 (7132)	
			Isolator Y-Dimension inches (mm)	1 (34)								87 (2206)								
			Point Load lbs (kgs)	851 (386)	851 (386)	1315 (596)	2167 (983)	701 (318)	701 (318)					845 (383)	845 (383)	1289 (585)	2224 (1009)	717 (325)	717 (325)	
19	8	B	Isolator X-Dimension inches (mm)	10 (263)	76 (1943)	118 (3000)	157 (3985)	209 (5299)	308 (7823)					10 (263)	76 (1943)	118 (3000)	157 (3985)	209 (5299)	308 (7823)	
			Isolator Y-Dimension inches (mm)	1 (34)								87 (2206)								
			Point Load lbs (kgs)	620 (281)	2105 (955)	664 (301)	664 (301)	2438 (1106)	603 (274)					600 (272)	2121 (962)	655 (297)	655 (297)	2511 (1139)	603 (274)	

Weights are based upon microchannel coil units.

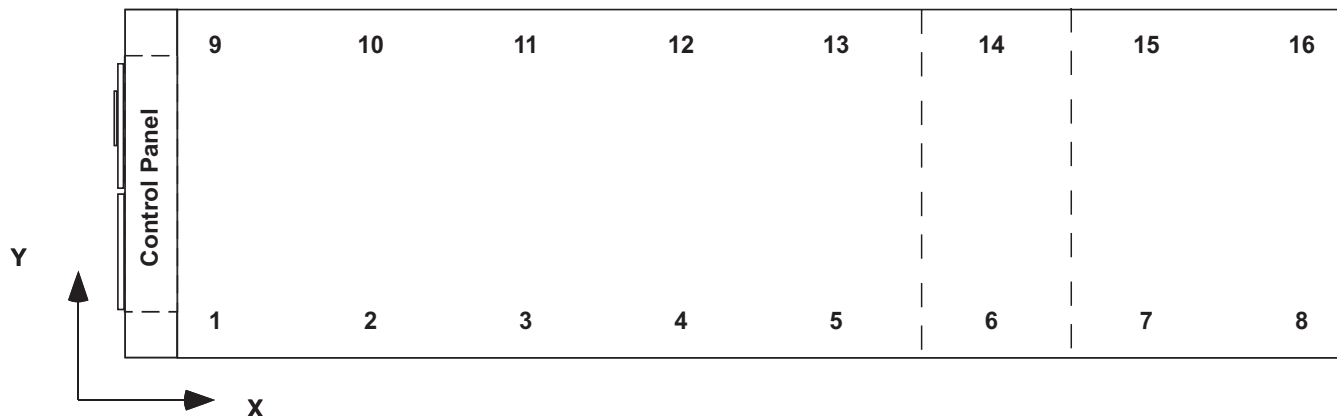

YVAA MODEL			DESCRIPTION	1	2	3	4	5	6	7	8	9	10	11	12	13	14	15	16	
FRAME	COND	EVAP																		
20	0	C	Isolator X-Dimension inches (mm)	10 (263)	76 (1943)	118 (3000)	157 (3985)	209 (5299)	281 (7136)			10 (263)	76 (1943)	118 (3000)	157 (3985)	209 (5299)	281 (7136)			
			Isolator Y-Dimension inches (mm)	1 (34)								87 (2206)								
			Point Load lbs (kgs)	853 (387)	853 (387)	1324 (601)	2202 (999)	709 (322)	709 (322)					847 (384)	847 (384)	1293 (586)	2228 (1011)	717 (325)	717 (325)	
21	3	A	Isolator X-Dimension inches (mm)	10 (263)	81 (2057)	149 (3779)	187 (4756)	251 (6368)					10 (263)	81 (2057)	149 (3779)	187 (4756)	251 (6368)			
			Isolator Y-Dimension inches (mm)	1 (34)								87 (2206)								
			Point Load lbs (kgs)	661 (300)	2075 (941)	1706 (774)	1706 (774)	1692 (767)						655 (297)	1990 (903)	1711 (776)	1711 (776)	1771 (803)		
21	5	C	Isolator X-Dimension inches (mm)	10 (263)	81 (2057)	149 (3779)	187 (4756)	235 (5968)	301 (7653)				10 (263)	81 (2057)	149 (3779)	187 (4756)	235 (5968)	301 (7653)		
			Isolator Y-Dimension inches (mm)	1 (34)								87 (2206)								
			Point Load lbs (kgs)	717 (325)	2727 (1237)	564 (256)	564 (256)	2431 (1103)	1216 (552)					704 (319)	2650 (1202)	571 (259)	571 (259)	2482 (1126)	1241 (563)	
21	8	C	Isolator X-Dimension inches (mm)	10 (263)	76 (1943)	118 (2999)	157 (3984)	209 (5298)	281 (7135)				10 (263)	76 (1943)	118 (2999)	157 (3984)	209 (5298)	281 (7135)		
			Isolator Y-Dimension inches (mm)	1 (34)								87 (2206)								
			Point Load lbs (kgs)	950 (431)	950 (431)	1426 (647)	2226 (1010)	658 (298)	658 (298)					936 (425)	936 (425)	1433 (650)	2243 (1017)	669 (303)	669 (303)	
23	3	B	Isolator X-Dimension inches (mm)	10 (263)	76 (1943)	128 (3260)	173 (4391)	220 (5579)	301 (7654)				10 (263)	76 (1943)	128 (3260)	173 (4391)	220 (5579)	301 (7654)		
			Isolator Y-Dimension inches (mm)	1 (34)								87 (2206)								
			Point Load lbs (kgs)	813 (369)	1915 (869)	1459 (662)	1459 (662)	1775 (805)	887 (402)					807 (366)	1825 (828)	1482 (672)	1482 (672)	1821 (826)	910 (413)	
24	5	C	Isolator X-Dimension inches (mm)	10 (263)	81 (2057)	143 (3638)	187 (4748)	245 (6232)	339 (8609)				10 (263)	81 (2057)	143 (3638)	187 (4748)	245 (6232)	339 (8609)		
			Isolator Y-Dimension inches (mm)	1 (34)								87 (2206)								
			Point Load lbs (kgs)	663 (301)	1795 (814)	2030 (921)	2030 (921)	1086 (493)	1086 (493)					663 (301)	1646 (747)	2097 (951)	2097 (951)	1102 (500)	1102 (500)	

Weights are based upon microchannel coil units.

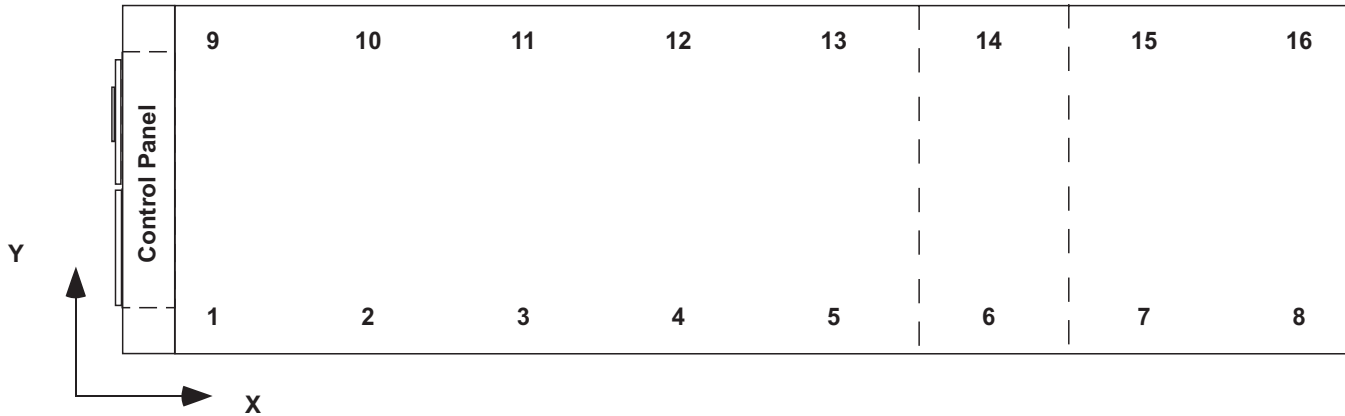

YVAA MODEL			DESCRIPTION	1	2	3	4	5	6	7	8	9	10	11	12	13	14	15	16	
FRAME	COND	EVAP		1	2	3	4	5	6	7	8	9	10	11	12	13	14	15	16	
24	8	C	Isolator X-Dimension inches (mm)	10 (263)	76 (1943)	118 (2999)	157 (3984)	209 (5298)	308 (7823)			10 (263)	76 (1943)	118 (2999)	157 (3984)	209 (5298)	308 (7823)			
			Isolator Y-Dimension inches (mm)	1 (34)								87 (2206)								
			Point Load lbs (kgs)	699 (317)	2111 (958)	694 (315)	694 (315)	2468 (1119)	604 (274)			680 (308)	2126 (964)	671 (304)	671 (304)	2518 (1142)	604 (274)			
26	3	B	Isolator X-Dimension inches (mm)	10 (263)	81 (2057)	161 (4084)	201 (5105)	301 (7654)					10 (263)	81 (2057)	161 (4084)	201 (5105)	301 (7654)			
			Isolator Y-Dimension inches (mm)	1 (34)								87 (2206)								
			Point Load lbs (kgs)	712 (323)	1544 (700)	2775 (1259)	2134 (968)	1387 (629)				682 (309)	1377 (625)	3032 (1375)	1944 (882)	1516 (688)				
27	3	D	Isolator X-Dimension inches (mm)	10 (263)	81 (2057)	161 (4084)	201 (5105)	301 (7654)					10 (263)	81 (2057)	161 (4084)	201 (5105)	301 (7654)			
			Isolator Y-Dimension inches (mm)	1 (34)								87 (2206)								
			Point Load lbs (kgs)	691 (313)	1646 (747)	2871 (1302)	2282 (1035)	1435 (651)				662 (300)	1480 (671)	3128 (1419)	2092 (949)	1564 (709)				
27	5	E	Isolator X-Dimension inches (mm)	10 (263)	81 (2057)	161 (4084)	201 (5105)	298 (7582)	339 (8609)				10 (263)	81 (2057)	161 (4084)	201 (5105)	298 (7582)	339 (8609)		
			Isolator Y-Dimension inches (mm)	1 (34)								87 (2206)								
			Point Load lbs (kgs)	652 (296)	1773 (804)	2533 (1149)	2533 (1149)	907 (411)	907 (411)			598 (271)	1733 (786)	2527 (1146)	2527 (1146)	961 (436)	961 (436)			
27	8	E	Isolator X-Dimension inches (mm)	10 (263)	81 (2057)	161 (4095)	201 (5105)	296 (7512)	339 (8609)				10 (263)	81 (2057)	161 (4095)	201 (5105)	296 (7512)	339 (8609)		
			Isolator Y-Dimension inches (mm)	1 (34)								87 (2206)								
			Point Load lbs (kgs)	693 (314)	1821 (826)	2532 (1148)	2532 (1148)	919 (417)	919 (417)			629 (285)	1830 (830)	2621 (1189)	2621 (1189)	973 (441)	973 (441)			
29	5	E	Isolator X-Dimension inches (mm)	10 (263)	81 (2057)	143 (3638)	187 (4748)	245 (6232)	339 (8609)				10 (259)	81 (2055)	143 (3635)	187 (4745)	245 (6228)	339 (8606)		
			Isolator Y-Dimension inches (mm)	1 (34)								87 (2206)								
			Point Load lbs (kgs)	711 (323)	1804 (818)	2071 (939)	2071 (939)	1083 (491)	1083 (491)			711 (323)	1668 (757)	2245 (1018)	2245 (1018)	1092 (495)	1092 (495)			
30	3	C	Isolator X-Dimension inches (mm)	10 (263)	81 (2057)	144 (3663)	187 (4755)	277 (7047)	383 (9726)				10 (263)	81 (2057)	144 (3663)	187 (4755)	277 (7047)	383 (9726)		
			Isolator Y-Dimension inches (mm)	1 (34)								87 (2206)								
			Point Load lbs (kgs)	870 (395)	1451 (658)	2185 (991)	2185 (991)	1652 (749)	861 (391)			765 (347)	1551 (704)	2240 (1016)	2240 (1016)	1779 (807)	861 (391)			

Weights are based upon microchannel coil units.

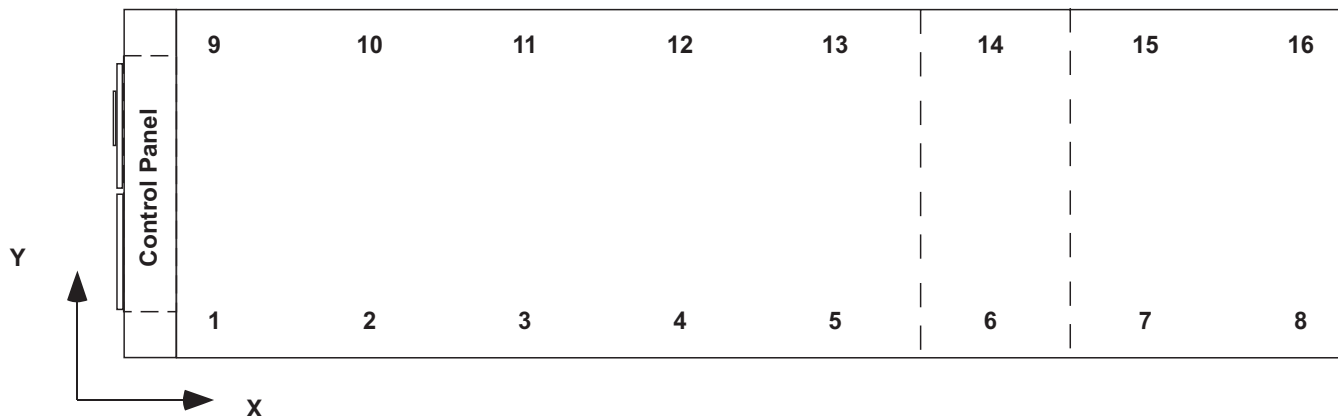

YVAA MODEL			DESCRIPTION	1	2	3	4	5	6	7	8	9	10	11	12	13	14	15	16
FRAME	COND	EVAP																	
30	5	C	Isolator X-Dimension inches (mm)	10 (260)	81 (2054)	161 (4081)	201 (5102)	298 (7579)	383 (9723)			10 (260)	81 (2054)	161 (4081)	201 (5102)	298 (7579)	383 (9723)		
			Isolator Y-Dimension inches (mm)	1 (34)								87 (2206)							
			Point Load lbs (kgs)	800 (363)	2001 (908)	2138 (970)	2138 (970)	1857 (842)	863 (391)			789 (358)	1968 (893)	2235 (1014)	2235 (1014)	1938 (879)	863 (391)		
30	8	E	Isolator X-Dimension inches (mm)	10 (263)	81 (2057)	161 (4084)	201 (5105)	298 (7582)	427 (10843)			10 (263)	81 (2057)	161 (4084)	201 (5105)	298 (7582)	427 (10843)		
			Isolator Y-Dimension inches (mm)	1 (34)								87 (2206)							
			Point Load lbs (kgs)	788 (357)	2032 (922)	2067 (938)	2067 (938)	2211 (1003)	1013 (459)			778 (353)	1999 (907)	2164 (982)	2164 (982)	2292 (1040)	1013 (459)		
31	8	E	Isolator X-Dimension inches (mm)	10 (263)	81 (2057)	161 (4084)	201 (5105)	298 (7582)	339 (8609)			10 (263)	81 (2057)	161 (4084)	201 (5105)	298 (7582)	339 (8609)		
			Isolator Y-Dimension inches (mm)	1 (34)								87 (2206)							
			Point Load lbs (kgs)	702 (318)	1771 (803)	2699 (1224)	2699 (1224)	918 (416)	918 (416)			635 (288)	1794 (814)	2675 (1213)	2675 (1213)	963 (437)	963 (437)		
32	3	E	Isolator X-Dimension inches (mm)	10 (263)	81 (2057)	161 (3636)	201 (4781)	298 (6232)	339 (9726)			10 (263)	81 (2057)	143 (3636)	188 (4781)	245 (6232)	383 (9726)		
			Isolator Y-Dimension inches (mm)	1 (34)								87 (2206)							
			Point Load lbs (kgs)	575 (261)	2930 (1329)	891 (404)	891 (404)	3346 (1518)	861 (391)			441 (200)	3177 (1441)	707 (321)	707 (321)	3601 (1633)	861 (391)		
33	3	C	Isolator X-Dimension inches (mm)	10 (260)	81 (2054)	161 (4081)	201 (5102)	298 (7579)	383 (9723)			10 (260)	81 (2054)	161 (4081)	201 (5102)	298 (7579)	383 (9723)		
			Isolator Y-Dimension inches (mm)	1 (34)								87 (2206)							
			Point Load lbs (kgs)	801 (363)	1996 (905)	2260 (1025)	2260 (1025)	1909 (866)	863 (391)			789 (358)	1967 (892)	2259 (1025)	2259 (1025)	1951 (885)	863 (391)		
34	3	E	Isolator X-Dimension inches (mm)	10 (263)	81 (2057)	161 (4084)	201 (5105)	298 (7582)	427 (10843)			10 (263)	81 (2057)	161 (4084)	201 (5105)	298 (7582)	427 (10843)		
			Isolator Y-Dimension inches (mm)	1 (34)								87 (2206)							
			Point Load lbs (kgs)	789 (358)	2027 (919)	2188 (992)	2188 (992)	2263 (1026)	1013 (459)			778 (353)	1998 (906)	2187 (992)	2187 (992)	2305 (1046)	1013 (459)		
34	5	E	Isolator X-Dimension inches (mm)	10 (263)	81 (2057)	161 (2908)	201 (5219)	298 (7218)	427 (10843)			10 (263)	81 (2057)	161 (2908)	201 (5219)	298 (7218)	427 (10843)		
			Isolator Y-Dimension inches (mm)	1 (34)								87 (2206)							
			Point Load lbs (kgs)	789 (355)	2027 (1188)	2188 (1403)	2188 (1403)	2263 (1388)	1013 (460)			778 (349)	1998 (1179)	2187 (1398)	2187 (1398)	2305 (1412)	1013 (460)		

Weights are based upon microchannel coil units.



YVAA MODEL			DESCRIPTION																
FRAME	COND	EVAP		1	2	3	4	5	6	7	8	9	10	11	12	13	14	15	16
36	8	J	Isolator X-Dimension inches (mm)	10 (254)	81 (2057)	145 (3683)	205 (5207)	284 (7214)	383 (9728)	439 (11151)	495 (12573)	10 (254)	81 (2057)	145 (3683)	205 (5207)	284 (7214)	383 (9728)	439 (11151)	495 (12573)
			Isolator Y-Dimension inches (mm)	1 (34)								87 (2206)							
			Point Load lbs (kgs)	710 (322)	1869 (848)	2719 (1233)	2719 (1233)	2969 (1347)	250 (113)	742 (337)	416 (189)	688 (312)	1826 (828)	3312 (1502)	3312 (1502)	3358 (1523)	46 (21)	839 (381)	413 (187)
37	3	F	Isolator X-Dimension inches (mm)	10 (263)	81 (2057)	145 (3680)	206 (5219)	284 (7218)	427 (10842)			10 (263)	81 (2057)	145 (3680)	206 (5219)	284 (7218)	427 (10842)		
			Isolator Y-Dimension inches (mm)	1 (34)								87 (2206)							
			Point Load lbs (kgs)	397 (180)	2636 (1196)	1895 (860)	1895 (860)	3216 (1459)	964 (437)			404 (183)	2486 (1128)	2575 (1168)	2575 (1168)	3399 (1542)	964 (437)		
37	5	J	Isolator X-Dimension inches (mm)	10 (254)	81 (2057)	145 (3683)	205 (5207)	284 (7214)	427 (10846)			10 (254)	81 (2057)	145 (3683)	205 (5207)	284 (7214)	427 (10846)		
			Isolator Y-Dimension inches (mm)	1 (34)								87 (2206)							
			Point Load lbs (kgs)	630 (286)	2277 (1033)	2458 (1115)	2458 (1115)	3227 (1464)	964 (437)			646 (293)	2117 (960)	3139 (1424)	3139 (1424)	3409 (1546)	964 (437)		
39	8	J	Isolator X-Dimension inches (mm)	10 (254)	81 (2057)	154 (3912)	206 (5232)	284 (7214)	427 (10846)	483 (12268)	539 (13691)	10 (254)	81 (2057)	154 (3912)	206 (5232)	284 (7214)	427 (10846)	483 (12268)	539 (13691)
			Isolator Y-Dimension inches (mm)	1 (34)								87 (2206)							
			Point Load lbs (kgs)	572 (259)	2139 (970)	2845 (1291)	2845 (1291)	2859 (1297)	897 (407)	478 (217)	429 (195)	547 (248)	2103 (954)	3399 (1542)	3399 (1542)	2982 (1352)	897 (407)	478 (217)	429 (195)
41	3	H	Isolator X-Dimension inches (mm)	10 (263)	81 (2057)	145 (3680)	205 (5219)	284 (7218)	427 (10843)			10 (263)	81 (2057)	145 (3680)	205 (5219)	284 (7218)	427 (10843)		
			Isolator Y-Dimension inches (mm)	1 (34)								87 (2206)							
			Point Load lbs (kgs)	496 (225)	2869 (1301)	1386 (629)	1386 (629)	3339 (1515)	964 (437)			513 (233)	2709 (1229)	1981 (899)	1981 (899)	3462 (1570)	964 (437)		
42	5	H	Isolator X-Dimension inches (mm)	10 (254)	81 (2057)	154 (3907)	206 (5219)	284 (7214)	427 (10846)	483 (12243)	539 (13691)	10 (254)	81 (2057)	154 (3683)	206 (5207)	284 (7214)	427 (10846)	483 (12243)	539 (13691)
			Isolator Y-Dimension inches (mm)	1 (34)								87 (2206)							
			Point Load lbs (kgs)	622 (282)	1876 (851)	2207 (1001)	2207 (1001)	2486 (1127)	897 (407)	478 (217)	429 (195)	598 (271)	1840 (835)	2760 (1252)	2760 (1252)	2608 (1183)	897 (407)	478 (217)	429 (195)
42	8	J	Isolator X-Dimension inches (mm)	10 (254)	81 (2057)	145 (3683)	205 (5207)	284 (7214)	427 (10846)	505 (12827)	562 (14275)	10 (254)	81 (2057)	145 (3683)	205 (5207)	284 (7214)	427 (10846)	505 (12827)	562 (14275)
			Isolator Y-Dimension inches (mm)	1 (34)								87 (2206)							
			Point Load lbs (kgs)	556 (252)	2460 (1116)	2572 (1167)	2572 (1167)	3003 (1362)	1138 (516)	382 (173)	761 (345)	659 (299)	2289 (1038)	3083 (1399)	3083 (1399)	3224 (1463)	1132 (513)	382 (173)	761 (345)

Weights are based upon microchannel coil units.

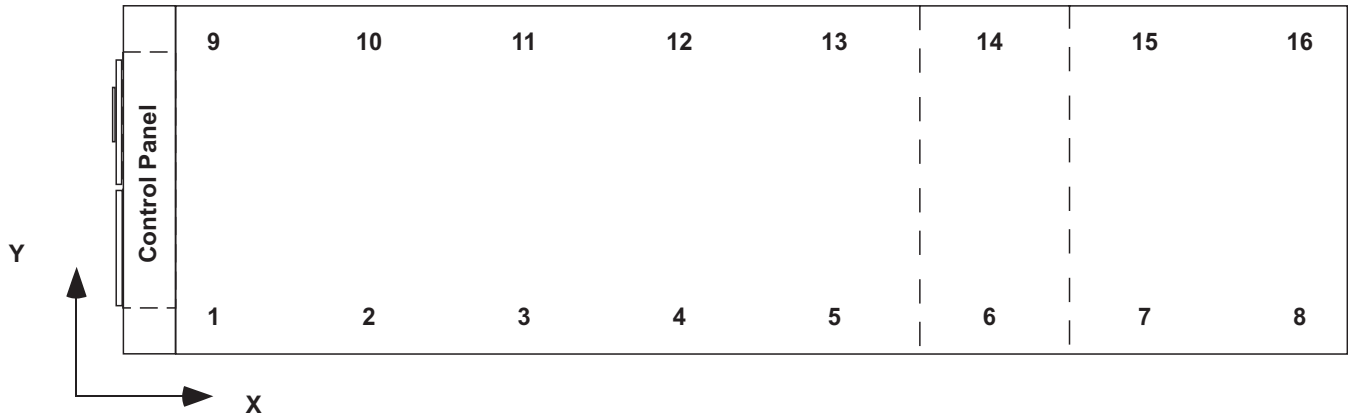

YVAA MODEL			DESCRIPTION	1	2	3	4	5	6	7	8	9	10	11	12	13	14	15	16
FRAME	COND	EVAP																	
44	3	G	Isolator X-Dimension inches (mm)	10 (263)	81 (2057)	154 (3907)	206 (5219)	284 (7218)	427 (10842)	483 (12274)	539 (13694)	10 (263)	81 (2057)	154 (3907)	206 (5219)	284 (7218)	427 (10842)	483 (12274)	539 (13694)
			Isolator Y-Dimension inches (mm)	1 (34)								87 (2206)							
			Point Load lbs (kgs)	676 (307)	2216 (1005)	3190 (1447)	3190 (1447)	2366 (1073)	976 (443)	452 (205)	436 (198)	657 (298)	2147 (974)	3182 (1443)	3182 (1443)	2469 (1120)	976 (443)	452 (205)	436 (198)
47	5	J	Isolator X-Dimension inches (mm)	10 (263)	81 (2057)	154 (3907)	206 (5219)	284 (7218)	427 (10842)	505 (12820)	562 (14265)	10 (263)	81 (2057)	154 (3907)	206 (5219)	284 (7218)	427 (10842)	505 (12820)	562 (14265)
			Isolator Y-Dimension inches (mm)	1 (34)								87 (2206)							
			Point Load lbs (kgs)	787 (357)	2418 (1097)	3310 (1501)	3310 (1501)	2720 (1234)	1202 (545)	386 (175)	759 (344)	765 (347)	2357 (1069)	3297 (1495)	3297 (1495)	2830 (1284)	1202 (545)	386 (175)	759 (344)
48	3	G	Isolator X-Dimension inches (mm)	10 (263)	81 (2057)	154 (3907)	206 (5219)	284 (7218)	427 (10842)	505 (12820)	562 (14265)	10 (263)	81 (2057)	154 (3907)	206 (5219)	284 (7218)	427 (10842)	505 (12820)	562 (14265)
			Isolator Y-Dimension inches (mm)	1 (34)								87 (2206)							
			Point Load lbs (kgs)	686 (311)	2160 (980)	3224 (1462)	3224 (1462)	2240 (1016)	1202 (545)	386 (175)	759 (344)	667 (303)	2092 (949)	3216 (1459)	3216 (1459)	2343 (1063)	1202 (545)	386 (175)	759 (344)
50	0	J	Isolator X-Dimension inches (mm)	10 (263)	81 (2057)	154 (2908)	205 (5219)	284 (7218)	427 (10843)			10 (263)	81 (2057)	154 (2908)	205 (5219)	284 (7218)	427 (10843)		
			Isolator Y-Dimension inches (mm)	1 (34)								87 (2206)							
			Point Load lbs (kgs)	783 (355)	2619 (1188)	3093 (1403)	3093 (1403)	3061 (1388)	1014 (460)			769 (349)	2600 (1179)	3083 (1398)	3083 (1398)	3113 (1412)	1014 (460)		
52	3	J	Isolator X-Dimension inches (mm)	10 (263)	81 (2057)	154 (3907)	206 (5219)	284 (7218)	427 (10842)	505 (12820)	562 (14265)	10 (263)	81 (2057)	154 (3907)	206 (5219)	284 (7218)	427 (10842)	505 (12820)	562 (14265)
			Isolator Y-Dimension inches (mm)	1 (34)								87 (2206)							
			Point Load lbs (kgs)	794 (360)	2611 (1184)	3112 (1412)	3112 (1412)	2916 (1323)	1202 (545)	386 (175)	759 (344)	772 (350)	2550 (1157)	3098 (1405)	3098 (1405)	3026 (1373)	1202 (545)	386 (175)	759 (344)

Weights are based upon microchannel coil units.

Isolators

ELASTOMERIC ISOLATOR

RD-Style Isolators

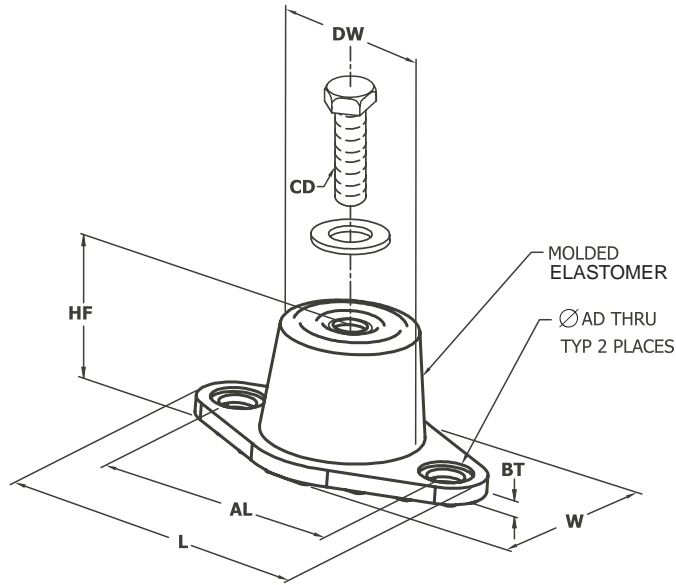

MOUNT TYPE	DIMENSION DATA (INCHES)							
	L	W	HF	AL	AD	BT	CD	DW
RD1-WR	3.13	1.75	1.25	2.38	0.34	0.19	5/16-18 UNC X 3/4	1.25
RD2-WR	3.88	2.38	1.75	3.00	0.34	0.22	3/8-16 UNC X 1	1.75
RD3-WR	5.50	3.38	2.88	4.13	0.56	0.25	1/2-13 UNC X 1	2.50
RD4-WR	6.25	4.63	2.75	5.00	0.56	0.38	1/2-13 UNC X 1	3.00

MODEL NUMBER	ISOLATOR COLOR	WEIGHT RANGE (LBS)	WEIGHT RANGE (KGS)
RD-3-CHARCOAL-WR	CHARCOAL	Thru 825	Thru 374
RD-4-BRICK RED-WR	BRICK RED	826 - 1688	375 - 766
RD-4-CHARCOAL-WR	CHARCOAL	1689 - 4000	767 - 1814

ONE INCH DEFLECTION SPRING ISOLATOR

CPX-X-

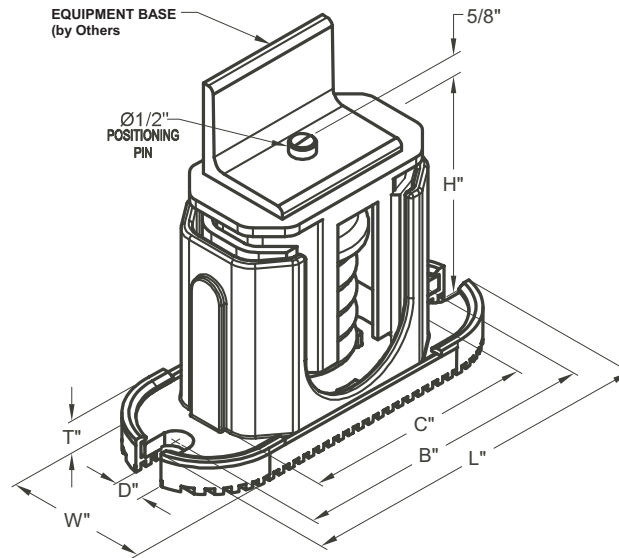

MOUNT TYPE	DIMENSION DATA (INCHES)						
	W	D	L	B	C	T	H
CP	3	5/8	7-3/4	6-1/2	4-3/4	1/2	5-5/8
C2P	3	5/8	10-1/2	9-1/4	7-3/4	9/16	6

MODEL NUMBER	COLOR CODE	RATED CAPACITY (FOR UNITS WITH ALL LOAD POINTS LESS THAN 1785 LBS (810 KG))	
		(LBS.)	(KG)
CP-1D-510	BLACK	Thru 434	Thru 197
CP-1D-900	DARK GREEN	435 - 765	198 - 347
CP-1D-1200	GRAY	766 - 1020	348 - 463
CP-1D-1360	WHITE	1021 - 1156	464 - 524
CP-1D-1785N	GRAY/RED	1157 - 1785	525 - 810

MODEL NUMBER	COLOR CODE	RATED CAPACITY (FOR UNITS WITH ANY LOAD POINT ABOVE 1518 LBS (689 KG))	
		(LBS.)	(KG)
C2P-1D-1350	DARK PURPLE	Thru 1148	Thru 521
C2P-1D-1800	DARK GREEN	1149 - 1530	522 - 694
C2P-1D-2400	GRAY	1531 - 2040	695 - 925
C2P-1D-2400	GRAY	1531 - 2040	695 - 925
C2P-1D-2720	WHITE	2041 - 2312	926 - 1049
C2P-1D-3570N	GRAY/RED	2313 - 3570	1050 - 1619

Electrical Data

FIELD WIRING LUGS					STANDARD & ULTRA QUIET CONDENSER FANS					
					TERMINAL BLOCK		CIRCUIT BREAKER		NON-FUSED DISCONNECT SWITCH	
YVAA MODEL			INPUT VOLTS	INPUT FREQ	WIRES PER PHASE	LUG WIRE RANGE	WIRES PER PHASE	LUG WIRE RANGE	WIRES PER PHASE	LUG WIRE RANGE
FRAME	COND	EVAP								
SINGLE POINT WIRING										
015	3	B	200	60	4	#2 - 600 kcmil				
			230	60	4	#2 - 600 kcmil	4	4/0 ~ 500 kcmil		
			380	60	2	#2 - 600 kcmil	2	#2/0 ~ 500 kcmil	2	#2 - 600 kcmil
			400	50	2	#2 - 600 kcmil	2	#2/0 ~ 500 kcmil	2	#2 - 600 kcmil
			460	60	2	#2 - 600 kcmil	2	#1 ~ 500 kcmil	2	#2 - 600 kcmil
016	5	B	575	60	2	#2 - 600 kcmil	2	#1 ~ 500 kcmil	2	#2 ~ 600 kcmil
			200	60	4	#2 - 600 kcmil				
			230	60	4	#2 - 600 kcmil	4	4/0 ~ 500 kcmil		
			380	60	2	#2 - 600 kcmil	2	#2/0 ~ 500 kcmil	2	#2 - 600 kcmil
			400	50	2	#2 - 600 kcmil	2	#2/0 ~ 500 kcmil	2	#2 - 600 kcmil
017	8	C	460	60	2	#2 - 600 kcmil	2	#1 ~ 500 kcmil	2	#2 - 600 kcmil
			575	60	2	#2 - 600 kcmil	2	#1 ~ 500 kcmil	2	#2 ~ 600 kcmil
			200	60	4	#2 - 600 kcmil				
			230	60	4	#2 - 600 kcmil	4	4/0 ~ 500 kcmil		
			380	60	2	#2 - 600 kcmil	2	#2/0 ~ 500 kcmil	2	#2 - 600 kcmil
018	3	A	400	50	2	#2 - 600 kcmil	2	#2/0 ~ 500 kcmil	2	#2 - 600 kcmil
			460	60	2	#2 - 600 kcmil	2	#1 ~ 500 kcmil	2	#2 - 600 kcmil
			575	60	2	#2 - 600 kcmil	2	#1 ~ 500 kcmil	2	#2 ~ 600 kcmil
			200	60	4	#2 - 600 kcmil				
			230	60	4	#2 - 600 kcmil	4	4/0 ~ 500 kcmil		
019	5	A	380	60	2	#2 - 600 kcmil	2	#1 ~ 500 kcmil	3	#2 ~ 600 kcmil
			400	50	2	#2 - 600 kcmil	2	#1 ~ 500 kcmil	3	#2 ~ 600 kcmil
			460	60	2	#2 - 600 kcmil	2	#1 ~ 500 kcmil	2	#2 - 600 kcmil
			575	60	2	#2 - 600 kcmil	2	#1 ~ 500 kcmil	2	#2 ~ 600 kcmil
			200	60	4	#2 - 600 kcmil				
019	8	B	230	60	4	#2 - 600 kcmil	4	4/0 ~ 500 kcmil		
			380	60	2	#2 - 600 kcmil	2	#1 ~ 500 kcmil	3	#2 ~ 600 kcmil
			400	50	2	#2 - 600 kcmil	2	#1 ~ 500 kcmil	3	#2 ~ 600 kcmil
			460	60	2	#2 - 600 kcmil	2	#1 ~ 500 kcmil	2	#2 - 600 kcmil
			575	60	2	#2 - 600 kcmil	2	#1 ~ 500 kcmil	2	#2 ~ 600 kcmil
020	0	C	200	60	4	#2 - 600 kcmil				
			230	60	4	#2 - 600 kcmil	4	4/0 ~ 500 kcmil		
			380	60	3	#2 - 600 kcmil	3	3/0 ~ 400 kcmil	3	#2 ~ 600 kcmil
			400	50	3	#2 - 600 kcmil	3	3/0 ~ 400 kcmil	3	#2 ~ 600 kcmil
			460	60	2	#2 - 600 kcmil	2	#1 ~ 500 kcmil	3	#2 - 600 kcmil
021	3	A	575	60	2	#2 - 600 kcmil	2	#1 ~ 500 kcmil	2	#2 ~ 600 kcmil
			200	60	4	#2 - 600 kcmil				
			230	60	4	#2 - 600 kcmil	4	4/0 ~ 500 kcmil		
			380	60	2	#2 - 600 kcmil	2	#1 ~ 500 kcmil	3	#2 ~ 600 kcmil
			400	50	2	#2 - 600 kcmil	2	#1 ~ 500 kcmil	3	#2 ~ 600 kcmil
			460	60	2	#2 - 600 kcmil	2	#1 ~ 500 kcmil	2	#2 - 600 kcmil
			575	60	2	#2 - 600 kcmil	2	#1 ~ 500 kcmil	2	#2 ~ 600 kcmil

FIELD WIRING LUGS					HIGH AIRFLOW/HIGH STATIC CONDENSER FANS						
					TERMINAL BLOCK		CIRCUIT BREAKER		NON-FUSED DISCONNECT SWITCH		
YVAA MODEL			INPUT VOLTS	INPUT FREQ	WIRE PER PHASE	LUG WIRE RANGE	WIRES PER PHASE	LUG WIRE RANGE	WIRES PER PHASE	LUG WIRE RANGE	
FRAME	COND	EVAP									
SINGLE POINT WIRING											
015	3	B	200	60	4	#1/0 ~ 700 kcmil					
			230	60	4	#2 - 600 kcmil	4	4/0 ~ 500 kcmil			
			380	60	2	#2 - 600 kcmil	2	#1 ~ 500 kcmil	3	#2 ~ 600 kcmil	
			400	50	2	#2 - 600 kcmil	2	#1 ~ 500 kcmil	3	#2 ~ 600 kcmil	
			460	60	2	#2 - 600 kcmil	2	#1 ~ 500 kcmil	3	#2 ~ 600 kcmil	
016	5	B	575	60	2	#2 - 600 kcmil	2	#1 ~ 500 kcmil	2	#2 ~ 600 kcmil	
			200	60	4	#1/0 ~ 700 kcmil					
			230	60	4	#2 - 600 kcmil	4	4/0 ~ 500 kcmil			
			380	60	2	#2 - 600 kcmil	2	#1 ~ 500 kcmil	3	#2 ~ 600 kcmil	
			400	50	2	#2 - 600 kcmil	2	#1 ~ 500 kcmil	3	#2 ~ 600 kcmil	
017	8	C	460	60	2	#2 - 600 kcmil	2	#1 ~ 500 kcmil	3	#2 ~ 600 kcmil	
			575	60	2	#2 - 600 kcmil	2	#1 ~ 500 kcmil	2	#2 ~ 600 kcmil	
			200	60	4	#1/0 ~ 700 kcmil					
			230	60	4	#2 - 600 kcmil	4	4/0 ~ 500 kcmil			
			380	60	2	#2 - 600 kcmil	2	#1 ~ 500 kcmil	3	#2 ~ 600 kcmil	
018	3	A	400	50	3	#2 - 600 kcmil	3	3/0 ~ 400 kcmil	3	#2 ~ 600 kcmil	
			460	60	2	#2 - 600 kcmil	2	#1 ~ 500 kcmil	3	#2 ~ 600 kcmil	
			575	60	2	#2 - 600 kcmil	2	#1 ~ 500 kcmil	2	#2 ~ 600 kcmil	
			200	60	4	#1/0 ~ 700 kcmil					
			230	60	4	#2 - 600 kcmil	4	4/0 ~ 500 kcmil			
019	5	A	380	60	3	#2 - 600 kcmil	3	3/0 ~ 400 kcmil	3	#2 ~ 600 kcmil	
			400	50	3	#2 - 600 kcmil	3	3/0 ~ 400 kcmil	3	#2 ~ 600 kcmil	
			460	60	2	#2 - 600 kcmil	2	#1 ~ 500 kcmil	3	#2 ~ 600 kcmil	
			575	60	2	#2 - 600 kcmil	2	#1 ~ 500 kcmil	2	#2 ~ 600 kcmil	
			200	60	4	#1/0 ~ 700 kcmil					
019	8	B	230	60	4	#2 - 600 kcmil	4	4/0 ~ 500 kcmil			
			380	60	3	#2 - 600 kcmil	3	3/0 ~ 400 kcmil	3	#2 ~ 600 kcmil	
			400	50	3	#2 - 600 kcmil	3	3/0 ~ 400 kcmil	3	#2 ~ 600 kcmil	
			460	60	2	#2 - 600 kcmil	2	#1 ~ 500 kcmil	3	#2 ~ 600 kcmil	
			575	60	2	#2 - 600 kcmil	2	#1 ~ 500 kcmil	2	#2 ~ 600 kcmil	
020	0	C	200	60	4	#1/0 ~ 700 kcmil					
			230	60	4	#2 - 600 kcmil	4	4/0 ~ 500 kcmil			
			380	60	3	#2 - 600 kcmil	3	3/0 ~ 400 kcmil	3	#2 ~ 600 kcmil	
			400	50	3	#2 - 600 kcmil	3	3/0 ~ 400 kcmil	3	#2 ~ 600 kcmil	
			460	60	3	#2 - 600 kcmil	3	3/0 ~ 400 kcmil	3	#2 ~ 600 kcmil	
021	3	A	575	60	2	#2 - 600 kcmil	2	#1 ~ 500 kcmil	2	#2 ~ 600 kcmil	
			200	60	4	#1/0 ~ 700 kcmil					
			230	60	4	#2 - 600 kcmil	4	4/0 ~ 500 kcmil			
			380	60	3	#2 - 600 kcmil	3	3/0 ~ 400 kcmil	3	#2 ~ 600 kcmil	
			400	50	3	#2 - 600 kcmil	3	3/0 ~ 400 kcmil	3	#2 ~ 600 kcmil	

FIELD WIRING LUGS					STANDARD & ULTRA QUIET CONDENSER FANS					
					TERMINAL BLOCK		CIRCUIT BREAKER		NON-FUSED DISCONNECT SWITCH	
YVAA MODEL			INPUT VOLTS	INPUT FREQ	WIRES PER PHASE	LUG WIRE RANGE	WIRES PER PHASE	LUG WIRE RANGE	WIRES PER PHASE	LUG WIRE RANGE
FRAME	COND	EVAP								
SINGLE POINT WIRING										
021	5	C	200	60	4	#2 - 600 kcmil				
			230	60	4	#2 - 600 kcmil	4	4/0 ~ 500 kcmil		
			380	60	2	#2 - 600 kcmil	2	#1 ~ 500 kcmil	3	#2 ~ 600 kcmil
			400	50	2	#2 - 600 kcmil	2	#1 ~ 500 kcmil	3	#2 ~ 600 kcmil
			460	60	2	#2 - 600 kcmil	2	#1 ~ 500 kcmil	2	#2 ~ 600 kcmil
			575	60	2	#2 - 600 kcmil	2	#1 ~ 500 kcmil	2	#2 ~ 600 kcmil
021	8	C	200	60	4	#2 - 600 kcmil				
			230	60	4	#2 - 600 kcmil	4	4/0 ~ 500 kcmil		
			380	60	2	#2 - 600 kcmil	2	#1 ~ 500 kcmil	3	#2 ~ 600 kcmil
			400	50	2	#2 - 600 kcmil	2	#1 ~ 500 kcmil	3	#2 ~ 600 kcmil
			460	60	2	#2 - 600 kcmil	2	#1 ~ 500 kcmil	2	#2 ~ 600 kcmil
			575	60	2	#2 - 600 kcmil	2	#1 ~ 500 kcmil	2	#2 ~ 600 kcmil
023	3	B	200	60	4	#2 - 600 kcmil				
			230	60	4	#2 - 600 kcmil	4	4/0 ~ 500 kcmil		
			380	60	3	#2 - 600 kcmil	3	3/0 ~ 400 kcmil	3	#2 ~ 600 kcmil
			400	50	3	#2 - 600 kcmil	3	3/0 ~ 400 kcmil	3	#2 ~ 600 kcmil
			460	60	2	#2 - 600 kcmil	2	#1 ~ 500 kcmil	3	#2 ~ 600 kcmil
			575	60	2	#2 - 600 kcmil	2	#1 ~ 500 kcmil	2	#2 ~ 600 kcmil
024	5	C	200	60	4	#2 - 600 kcmil				
			230	60	4	#2 - 600 kcmil	4	4/0 ~ 500 kcmil		
			380	60	3	#2 - 600 kcmil	3	3/0 ~ 400 kcmil	3	#2 ~ 600 kcmil
			400	50	3	#2 - 600 kcmil	3	3/0 ~ 400 kcmil	3	#2 ~ 600 kcmil
			460	60	2	#2 - 600 kcmil	2	#1 ~ 500 kcmil	3	#2 ~ 600 kcmil
			575	60	2	#2 - 600 kcmil	2	#1 ~ 500 kcmil	2	#2 ~ 600 kcmil
024	8	C	200	60	4	#2 - 600 kcmil				
			230	60	4	#2 - 600 kcmil	4	4/0 ~ 500 kcmil		
			380	60	3	#2 - 600 kcmil	3	3/0 ~ 400 kcmil	3	#2 ~ 600 kcmil
			400	50	3	#2 - 600 kcmil	3	3/0 ~ 400 kcmil	3	#2 ~ 600 kcmil
			460	60	2	#2 - 600 kcmil	2	#1 ~ 500 kcmil	3	#2 ~ 600 kcmil
			575	60	2	#2 - 600 kcmil	2	#1 ~ 500 kcmil	2	#2 ~ 600 kcmil
026	3	B	200	60	4	#2 - 600 kcmil				
			230	60	4	#2 - 600 kcmil	4	4/0 ~ 500 kcmil		
			380	60	3	#2 - 600 kcmil	3	3/0 ~ 400 kcmil	3	#2 ~ 600 kcmil
			400	50	3	#2 - 600 kcmil	3	3/0 ~ 400 kcmil	3	#2 ~ 600 kcmil
			460	60	2	#2 - 600 kcmil	2	#1 ~ 500 kcmil	3	#2 ~ 600 kcmil
			575	60	2	#2 - 600 kcmil	2	#1 ~ 500 kcmil	2	#2 ~ 600 kcmil
027	3	D	200	60	4	#2 - 600 kcmil				
			230	60	4	#2 - 600 kcmil	4	4/0 ~ 500 kcmil		
			380	60	3	#2 - 600 kcmil	3	3/0 ~ 400 kcmil	3	#2 ~ 600 kcmil
			400	50	3	#2 - 600 kcmil	3	3/0 ~ 400 kcmil	3	#2 ~ 600 kcmil
			460	60	2	#2 - 600 kcmil	2	#1 ~ 500 kcmil	3	#2 ~ 600 kcmil
			575	60	2	#2 - 600 kcmil	2	#1 ~ 500 kcmil	2	#2 ~ 600 kcmil
027	5	E	200	60	4	#2 - 600 kcmil				
			230	60	4	#2 - 600 kcmil	4	4/0 ~ 500 kcmil		
			380	60	3	#2 - 600 kcmil	3	3/0 ~ 400 kcmil	3	#2 ~ 600 kcmil
			400	50	3	#2 - 600 kcmil	3	3/0 ~ 400 kcmil	3	#2 ~ 600 kcmil
			460	60	2	#2 - 600 kcmil	2	#1 ~ 500 kcmil	3	#2 ~ 600 kcmil
			575	60	2	#2 - 600 kcmil	2	#1 ~ 500 kcmil	2	#2 ~ 600 kcmil
027	8	E	200	60	4	#2 - 600 kcmil				
			230	60	4	#2 - 600 kcmil	4	4/0 ~ 500 kcmil		
			380	60	3	#2 - 600 kcmil	3	3/0 ~ 400 kcmil	3	#2 ~ 600 kcmil
			400	50	3	#2 - 600 kcmil	3	3/0 ~ 400 kcmil	3	#2 ~ 600 kcmil
			460	60	2	#2 - 600 kcmil	2	#1 ~ 500 kcmil	3	#2 ~ 600 kcmil
			575	60	2	#2 - 600 kcmil	2	#1 ~ 500 kcmil	2	#2 ~ 600 kcmil

FIELD WIRING LUGS					HIGH AIRFLOW/HIGH STATIC CONDENSER FANS						
					TERMINAL BLOCK		CIRCUIT BREAKER		NON-FUSED DISCONNECT SWITCH		
YVAA MODEL			INPUT VOLTS	INPUT FREQ	WIRE PER PHASE	LUG WIRE RANGE	WIRES PER PHASE	LUG WIRE RANGE	WIRES PER PHASE	LUG WIRE RANGE	
FRAME	COND	EVAP									
SINGLE POINT WIRING											
021	5	C	200	60	4	#1/0 ~ 700 kcmil					
			230	60	4	#2 - 600 kcmil	4	4/0 ~ 500 kcmil			
			380	60	3	#2 - 600 kcmil	3	3/0 ~ 400 kcmil	3	#2 ~ 600 kcmil	
			400	50	3	#2 - 600 kcmil	3	3/0 ~ 400 kcmil	3	#2 ~ 600 kcmil	
			460	60	2	#2 - 600 kcmil	2	#1 ~ 500 kcmil	3	#2 ~ 600 kcmil	
			575	60	2	#2 - 600 kcmil	2	#1 ~ 500 kcmil	2	#2 ~ 600 kcmil	
021	8	C	200	60	4	#1/0 ~ 700 kcmil					
			230	60	4	#2 - 600 kcmil	4	4/0 ~ 500 kcmil			
			380	60	3	#2 - 600 kcmil	3	3/0 ~ 400 kcmil	3	#2 ~ 600 kcmil	
			400	50	3	#2 - 600 kcmil	3	3/0 ~ 400 kcmil	3	#2 ~ 600 kcmil	
			460	60	2	#2 - 600 kcmil	2	#1 ~ 500 kcmil	3	#2 ~ 600 kcmil	
			575	60	2	#2 - 600 kcmil	2	#1 ~ 500 kcmil	2	#2 ~ 600 kcmil	
023	3	B	200	60	4	#1/0 ~ 700 kcmil					
			230	60	4	#2 - 600 kcmil	4	4/0 ~ 500 kcmil			
			380	60	3	#2 - 600 kcmil	3	3/0 ~ 400 kcmil	3	#2 ~ 600 kcmil	
			400	50	3	#2 - 600 kcmil	3	3/0 ~ 400 kcmil	3	#2 ~ 600 kcmil	
			460	60	3	#2 - 600 kcmil	3	3/0 ~ 400 kcmil	3	#2 ~ 600 kcmil	
			575	60	2	#2 - 600 kcmil	2	#1 - 500 kcmil	2	#2 ~ 600 kcmil	
024	5	C	200	60	4	#1/0 ~ 700 kcmil					
			230	60	4	#2 - 600 kcmil	4	4/0 ~ 500 kcmil			
			380	60	3	#2 - 600 kcmil	3	3/0 ~ 400 kcmil	3	#2 ~ 600 kcmil	
			400	50	3	#2 - 600 kcmil	3	3/0 ~ 400 kcmil	3	#2 ~ 600 kcmil	
			460	60	3	#2 - 600 kcmil	3	3/0 ~ 400 kcmil	3	#2 ~ 600 kcmil	
			575	60	2	#2 - 600 kcmil	2	#1 - 500 kcmil	2	#2 ~ 600 kcmil	
024	8	C	200	60	4	#1/0 ~ 700 kcmil					
			230	60	4	#2 - 600 kcmil	4	4/0 ~ 500 kcmil			
			380	60	3	#2 - 600 kcmil	3	3/0 ~ 400 kcmil	3	#2 ~ 600 kcmil	
			400	50	3	#2 - 600 kcmil	3	3/0 ~ 400 kcmil	3	#2 ~ 600 kcmil	
			460	60	3	#2 - 600 kcmil	3	3/0 ~ 400 kcmil	3	#2 ~ 600 kcmil	
			575	60	2	#2 - 600 kcmil	2	#1 - 500 kcmil	2	#2 ~ 600 kcmil	
026	3	B	200	60	4	#1/0 ~ 700 kcmil					
			230	60	4	#2 - 600 kcmil	4	4/0 ~ 500 kcmil			
			380	60	3	#2 - 600 kcmil	3	3/0 ~ 400 kcmil	3	#2 ~ 600 kcmil	
			400	50	3	#2 - 600 kcmil	3	3/0 ~ 400 kcmil	3	#2 ~ 600 kcmil	
			460	60	3	#2 - 600 kcmil	3	3/0 ~ 400 kcmil	3	#2 ~ 600 kcmil	
			575	60	2	#2 - 600 kcmil	2	#1 - 500 kcmil	2	#2 ~ 600 kcmil	
027	3	D	200	60	4	#1/0 ~ 700 kcmil					
			230	60	4	#2 - 600 kcmil	4	4/0 ~ 500 kcmil			
			380	60	3	#2 - 600 kcmil	3	3/0 ~ 400 kcmil	3	#2 ~ 600 kcmil	
			400	50	3	#2 - 600 kcmil	3	3/0 ~ 400 kcmil	3	#2 ~ 600 kcmil	
			460	60	3	#2 - 600 kcmil	3	3/0 ~ 400 kcmil	3	#2 ~ 600 kcmil	
			575	60	2	#2 - 600 kcmil	2	#1 ~ 500 kcmil	2	#2 ~ 600 kcmil	
027	5	E	200	60	4	#1/0 ~ 700 kcmil					
			230	60	4	#2 - 600 kcmil	4	4/0 ~ 500 kcmil			
			380	60	3	#2 - 600 kcmil	3	3/0 ~ 400 kcmil	3	#2 ~ 600 kcmil	
			400	50	3	#2 - 600 kcmil	3	3/0 ~ 400 kcmil	3	#2 ~ 600 kcmil	
			460	60	3	#2 - 600 kcmil	3	3/0 ~ 400 kcmil	3	#2 ~ 600 kcmil	
			575	60	2	#2 - 600 kcmil	2	#1 - 500 kcmil	2	#2 ~ 600 kcmil	
027	8	E	200	60	4	#1/0 ~ 700 kcmil					
			230	60	4	#2 - 600 kcmil	4	4/0 ~ 500 kcmil			
			380	60	3	#2 - 600 kcmil	3	3/0 ~ 400 kcmil	3	#2 ~ 600 kcmil	
			400	50	3	#2 - 600 kcmil	3	3/0 ~ 400 kcmil	3	#2 ~ 600 kcmil	
			460	60	3	#2 - 600 kcmil	3	3/0 ~ 400 kcmil	3	#2 ~ 600 kcmil	
			575	60	2	#2 - 600 kcmil	2	#1 - 500 kcmil	2	#2 ~ 600 kcmil	

FIELD WIRING LUGS					STANDARD & ULTRA QUIET CONDENSER FANS					
					TERMINAL BLOCK		CIRCUIT BREAKER		NON-FUSED DISCONNECT SWITCH	
YVAA MODEL			INPUT VOLTS	INPUT FREQ	WIRES PER PHASE	LUG WIRE RANGE	WIRES PER PHASE	LUG WIRE RANGE	WIRES PER PHASE	LUG WIRE RANGE
FRAME	COND	EVAP								
SINGLE POINT WIRING										
029	5	E	200	60						
			230	60						
			380	60	3	#2 - 600 kcmil	4	#4/0 ~ 500 kcmil	4*	#2 - 600 kcmil
			400	50	3	#2 - 600 kcmil	4	#4/0 ~ 500 kcmil	3	#2 ~ 600 kcmil
			460	60	3	#2 - 600 kcmil	3	#3/0 ~ 400 kcmil	3	#2 ~ 600 kcmil
			575	60	3	#2 - 600 kcmil	3	#3/0 ~ 400 kcmil	3	#2 ~ 600 kcmil
030	3	C	200	60						
			230	60						
			380	60	3	#2 - 600 kcmil	4	#4/0 ~ 500 kcmil	4*	#2 - 600 kcmil
			400	50	3	#2 - 600 kcmil	4	#4/0 ~ 500 kcmil	3	#2 ~ 600 kcmil
			460	60	3	#2 - 600 kcmil	3	#3/0 ~ 400 kcmil	3	#2 ~ 600 kcmil
			575	60	3	#2 - 600 kcmil	3	#3/0 ~ 400 kcmil	3	#2 ~ 600 kcmil
030	5	C	200	60						
			230	60						
			380	60	3	#2 - 600 kcmil	4	#4/0 ~ 500 kcmil	4*	#2 - 600 kcmil
			400	50	3	#2 - 600 kcmil	4	#4/0 ~ 500 kcmil	3	#2 ~ 600 kcmil
			460	60	3	#2 - 600 kcmil	3	#3/0 ~ 400 kcmil	3	#2 ~ 600 kcmil
			575	60	3	#2 - 600 kcmil	3	#3/0 ~ 400 kcmil	3	#2 ~ 600 kcmil
030	8	E	200	60						
			230	60						
			380	60	3	#2 - 600 kcmil	4	#4/0 ~ 500 kcmil	4*	#2 - 600 kcmil
			400	50	3	#2 - 600 kcmil	4	#4/0 ~ 500 kcmil	3	#2 ~ 600 kcmil
			460	60	3	#2 - 600 kcmil	3	#3/0 ~ 400 kcmil	3	#2 ~ 600 kcmil
			575	60	3	#2 - 600 kcmil	3	#3/0 ~ 400 kcmil	3	#2 ~ 600 kcmil
031	8	E	200	60						
			230	60						
			380	60	3	#2 - 600 kcmil	4	#4/0 ~ 500 kcmil	4*	#2 - 600 kcmil
			400	50	3	#2 - 600 kcmil	4	#4/0 ~ 500 kcmil	3	#2 ~ 600 kcmil
			460	60	3	#2 - 600 kcmil	3	#3/0 ~ 400 kcmil	3	#2 ~ 600 kcmil
			575	60	3	#2 - 600 kcmil	3	#3/0 ~ 400 kcmil	3	#2 ~ 600 kcmil
032	3	E	200	60						
			230	60						
			380	60	3	#2 - 600 kcmil	4	#4/0 ~ 500 kcmil	4*	#2 - 600 kcmil
			400	50	3	#2 - 600 kcmil	4	#4/0 ~ 500 kcmil	3	#2 ~ 600 kcmil
			460	60	3	#2 - 600 kcmil	3	#3/0 ~ 400 kcmil	3	#2 ~ 600 kcmil
			575	60	3	#2 - 600 kcmil	3	#3/0 ~ 400 kcmil	3	#2 ~ 600 kcmil
033	3	C	200	60						
			230	60						
			380	60	3	#2 - 600 kcmil	4	#4/0 ~ 500 kcmil	4*	#2 - 600 kcmil
			400	50	3	#2 - 600 kcmil	4	#4/0 ~ 500 kcmil	3	#2 ~ 600 kcmil
			460	60	3	#2 - 600 kcmil	3	#3/0 ~ 400 kcmil	3	#2 ~ 600 kcmil
			575	60	3	#2 - 600 kcmil	3	#3/0 ~ 400 kcmil	3	#2 ~ 600 kcmil
034	3	E	200	60						
			230	60						
			380	60	3	#2 - 600 kcmil	4	#4/0 ~ 500 kcmil	4*	#2 - 600 kcmil
			400	50	3	#2 - 600 kcmil	4	#4/0 ~ 500 kcmil	3	#2 ~ 600 kcmil
			460	60	3	#2 - 600 kcmil	3	#3/0 ~ 400 kcmil	3	#2 ~ 600 kcmil
			575	60	3	#2 - 600 kcmil	3	#3/0 ~ 400 kcmil	3	#2 ~ 600 kcmil
034	5	E	200	60						
			230	60						
			380	60	3	#2 - 600 kcmil	4	#4/0 ~ 500 kcmil	4*	#2 - 600 kcmil
			400	50	3	#2 - 600 kcmil	4	#4/0 ~ 500 kcmil	3	#2 ~ 600 kcmil
			460	60	3	#2 - 600 kcmil	3	#3/0 ~ 400 kcmil	3	#2 ~ 600 kcmil
			575	60	3	#2 - 600 kcmil	3	#3/0 ~ 400 kcmil	3	#2 ~ 600 kcmil

FIELD WIRING LUGS					HIGH AIRFLOW/HIGH STATIC CONDENSER FANS					
					TERMINAL BLOCK		CIRCUIT BREAKER		NON-FUSED DISCONNECT SWITCH	
YVAA MODEL			INPUT VOLTS	INPUT FREQ	WIRE PER PHASE	LUG WIRE RANGE	WIRES PER PHASE	LUG WIRE RANGE	WIRES PER PHASE	LUG WIRE RANGE
FRAME	COND	EVAP								
SINGLE POINT WIRING										
029	5	E	200	60						
			230	60						
			380	60	4	#2 - 600 kcmil	4	#4/0 ~ 500 kcmil	4*	#2 - 600 kcmil
			400	50	4	#2 - 600 kcmil	4	#4/0 ~ 500 kcmil	4*	#2 - 600 kcmil
			460	60	3	#2 - 600 kcmil	4	#4/0 ~ 500 kcmil	3	#2 - 600 kcmil
			575	60	3	#2 - 600 kcmil	3	#3/0 ~ 400 kcmil	3	#2 - 600 kcmil
030	3	C	200	60						
			230	60						
			380	60	4	#2 - 600 kcmil	4	#4/0 ~ 500 kcmil	4*	#2 - 600 kcmil
			400	50	4	#2 - 600 kcmil	4	#4/0 ~ 500 kcmil	4*	#2 - 600 kcmil
			460	60	3	#2 - 600 kcmil	4	#4/0 ~ 500 kcmil	3	#2 - 600 kcmil
			575	60	3	#2 - 600 kcmil	3	#3/0 ~ 400 kcmil	3	#2 - 600 kcmil
030	5	C	200	60						
			230	60						
			380	60	4	#2 - 600 kcmil	4	#4/0 ~ 500 kcmil	4*	#2 - 600 kcmil
			400	50	4	#2 - 600 kcmil	4	#4/0 ~ 500 kcmil	4*	#2 - 600 kcmil
			460	60	3	#2 - 600 kcmil	4	#4/0 ~ 500 kcmil	3	#2 - 600 kcmil
			575	60	3	#2 - 600 kcmil	3	#3/0 ~ 400 kcmil	3	#2 - 600 kcmil
030	8	E	200	60						
			230	60						
			380	60	4	#2 - 600 kcmil	4	#4/0 ~ 500 kcmil	4*	#2 - 600 kcmil
			400	50	4	#2 - 600 kcmil	4	#4/0 ~ 500 kcmil	4*	#2 - 600 kcmil
			460	60	3	#2 - 600 kcmil	4	#4/0 ~ 500 kcmil	3	#2 - 600 kcmil
			575	60	3	#2 - 600 kcmil	3	#3/0 ~ 400 kcmil	3	#2 - 600 kcmil
031	8	E	200	60						
			230	60						
			380	60	4	#2 - 600 kcmil	4	#4/0 ~ 500 kcmil	4*	#2 - 600 kcmil
			400	50	4	#2 - 600 kcmil	4	#4/0 ~ 500 kcmil	4*	#2 - 600 kcmil
			460	60	3	#2 - 600 kcmil	4	#4/0 ~ 500 kcmil	3	#2 - 600 kcmil
			575	60	3	#2 - 600 kcmil	3	#3/0 ~ 400 kcmil	3	#2 - 600 kcmil
032	3	E	200	60						
			230	60						
			380	60	4	#2 - 600 kcmil	4	#4/0 ~ 500 kcmil	4*	#2 - 600 kcmil
			400	50	4	#2 - 600 kcmil	4	#4/0 ~ 500 kcmil	4*	#2 - 600 kcmil
			460	60	3	#2 - 600 kcmil	4	#4/0 ~ 500 kcmil	3	#2 - 600 kcmil
			575	60	3	#2 - 600 kcmil	3	#3/0 ~ 400 kcmil	3	#2 - 600 kcmil
033	3	C	200	60						
			230	60						
			380	60	4	#2 - 600 kcmil	4	#4/0 ~ 500 kcmil	4*	#2 - 600 kcmil
			400	50	4	#2 - 600 kcmil	4	#4/0 ~ 500 kcmil	4*	#2 - 600 kcmil
			460	60	3	#2 - 600 kcmil	4	#4/0 ~ 500 kcmil	3	#2 - 600 kcmil
			575	60	3	#2 - 600 kcmil	3	#3/0 ~ 400 kcmil	3	#2 - 600 kcmil
034	3	E	200	60						
			230	60						
			380	60	4	#2 - 600 kcmil	4	#4/0 ~ 500 kcmil	4*	#2 - 600 kcmil
			400	50	4	#2 - 600 kcmil	4	#4/0 ~ 500 kcmil	4*	#2 - 600 kcmil
			460	60	3	#2 - 600 kcmil	4	#4/0 ~ 500 kcmil	3	#2 - 600 kcmil
			575	60	3	#2 - 600 kcmil	3	#3/0 ~ 400 kcmil	3	#2 - 600 kcmil
034	5	E	200	60						
			230	60						
			380	60	4	#2 - 600 kcmil	4	#4/0 ~ 500 kcmil	4*	#2 - 600 kcmil
			400	50	4	#2 - 600 kcmil	4	#4/0 ~ 500 kcmil	4*	#2 - 600 kcmil
			460	60	3	#2 - 600 kcmil	4	#4/0 ~ 500 kcmil	3	#2 - 600 kcmil
			575	60	3	#2 - 600 kcmil	3	#3/0 ~ 400 kcmil	3	#2 - 600 kcmil

FIELD WIRING LUGS					STANDARD & ULTRA QUIET CONDENSER FANS					
					TERMINAL BLOCK		CIRCUIT BREAKER		NON-FUSED DISCONNECT SWITCH	
YVAA MODEL			INPUT VOLTS	INPUT FREQ	WIRES PER PHASE	LUG WIRE RANGE	WIRES PER PHASE	LUG WIRE RANGE	WIRES PER PHASE	LUG WIRE RANGE
FRAME	COND	EVAP								
DUAL POINT WIRING										
036	8	J	200	60						
			230	60						
			380	60	3	#2 - 600 kcmil	3	#3/0 ~ 400 kcmil	3	#3/0 ~ 400 kcmil
			400	50	3	#2 - 600 kcmil	3	#3/0 ~ 400 kcmil	3	#3/0 ~ 400 kcmil
			460	60	2	#2 - 600 kcmil	2	#1 ~ 500 kcmil	2	#1 ~ 500 kcmil
037	3	F	200	60						
			230	60						
			380	60	3	#2 - 600 kcmil	3	#3/0 ~ 400 kcmil	3	#3/0 ~ 400 kcmil
			400	50	3	#2 - 600 kcmil	3	#3/0 ~ 400 kcmil	3	#3/0 ~ 400 kcmil
			460	60	2	#2 - 600 kcmil	2	#1 ~ 500 kcmil	2	#1 ~ 500 kcmil
037	5	J	200	60						
			230	60						
			380	60	3	#2 - 600 kcmil	3	#3/0 ~ 400 kcmil	3	#3/0 ~ 400 kcmil
			400	50	3	#2 - 600 kcmil	3	#3/0 ~ 400 kcmil	3	#3/0 ~ 400 kcmil
			460	60	2	#2 - 600 kcmil	2	#1 ~ 500 kcmil	2	#1 ~ 500 kcmil
039	8	J	200	60						
			230	60						
			380	60	3	#2 - 600 kcmil	3	#3/0 ~ 400 kcmil	3	#3/0 ~ 400 kcmil
			400	50	3	#2 - 600 kcmil	3	#3/0 ~ 400 kcmil	3	#3/0 ~ 400 kcmil
			460	60	2	#2 - 600 kcmil	2	#1 ~ 500 kcmil	2	#1 ~ 500 kcmil
041	3	H	200	60						
			230	60						
			380	60	3	#2 - 600 kcmil	3	#3/0 ~ 400 kcmil	3	#3/0 ~ 400 kcmil
			400	50	3	#2 - 600 kcmil	3	#3/0 ~ 400 kcmil	3	#3/0 ~ 400 kcmil
			460	60	2	#2 - 600 kcmil	2	#1 ~ 500 kcmil	2	#1 ~ 500 kcmil
042	5	H	200	60						
			230	60						
			380	60	3	#2 - 600 kcmil	3	#3/0 ~ 400 kcmil	3	#3/0 ~ 400 kcmil
			400	50	3	#2 - 600 kcmil	3	#3/0 ~ 400 kcmil	3	#3/0 ~ 400 kcmil
			460	60	2	#2 - 600 kcmil	2	#1 ~ 500 kcmil	2	#1 ~ 500 kcmil
042	8	J	200	60						
			230	60						
			380	60	3	#2 - 600 kcmil	3	#3/0 ~ 400 kcmil	3	#3/0 ~ 400 kcmil
			400	50	3	#2 - 600 kcmil	3	#3/0 ~ 400 kcmil	3	#3/0 ~ 400 kcmil
			460	60	2	#2 - 600 kcmil	2	#1 ~ 500 kcmil	2	#1 ~ 500 kcmil
044	3	G	200	60						
			230	60						
			380	60	3	#2 - 600 kcmil	3	#3/0 ~ 400 kcmil	3	#3/0 ~ 400 kcmil
			400	50	3	#2 - 600 kcmil	3	#3/0 ~ 400 kcmil	3	#3/0 ~ 400 kcmil
			460	60	2	#2 - 600 kcmil	2	#1 ~ 500 kcmil	2	#1 ~ 500 kcmil
047	5	J	200	60						
			230	60						
			380	60	3	#2 - 600 kcmil	3	#3/0 ~ 400 kcmil	3	#3/0 ~ 400 kcmil
			400	50	3	#2 - 600 kcmil	3	#3/0 ~ 400 kcmil	3	#3/0 ~ 400 kcmil
			460	60	2	#2 - 600 kcmil	2	#1 ~ 500 kcmil	2	#1 ~ 500 kcmil
047	5	J	200	60						
			230	60						
			380	60	3	#2 - 600 kcmil	3	#3/0 ~ 400 kcmil	3	#3/0 ~ 400 kcmil
			400	50	3	#2 - 600 kcmil	3	#3/0 ~ 400 kcmil	3	#3/0 ~ 400 kcmil
			460	60	2	#2 - 600 kcmil	2	#1 ~ 500 kcmil	2	#1 ~ 500 kcmil
047	5	J	200	60						
			230	60						
			380	60	3	#2 - 600 kcmil	3	#3/0 ~ 400 kcmil	3	#3/0 ~ 400 kcmil
			400	50	3	#2 - 600 kcmil	3	#3/0 ~ 400 kcmil	3	#3/0 ~ 400 kcmil
			460	60	2	#2 - 600 kcmil	2	#1 ~ 500 kcmil	2	#1 ~ 500 kcmil
047	5	J	200	60						
			230	60						
			380	60	3	#2 - 600 kcmil	3	#3/0 ~ 400 kcmil	3	#3/0 ~ 400 kcmil
			400	50	3	#2 - 600 kcmil	3	#3/0 ~ 400 kcmil	3	#3/0 ~ 400 kcmil
			460	60	2	#2 - 600 kcmil	2	#1 ~ 500 kcmil	2	#1 ~ 500 kcmil
047	5	J	200	60						
			230	60						
			380	60	3	#2 - 600 kcmil	3	#3/0 ~ 400 kcmil	3	#3/0 ~ 400 kcmil
			400	50	3	#2 - 600 kcmil	3	#3/0 ~ 400 kcmil	3	#3/0 ~ 400 kcmil
			460	60	2	#2 - 600 kcmil	2	#1 ~ 500 kcmil	2	#1 ~ 500 kcmil
047	5	J	200	60						
			230	60						
			380	60	3	#2 - 600 kcmil	3	#3/0 ~ 400 kcmil	3	#3/0 ~ 400 kcmil
			400	50	3	#2 - 600 kcmil	3	#3/0 ~ 400 kcmil	3	#3/0 ~ 400 kcmil
			460	60	2	#2 - 600 kcmil	2	#1 ~ 500 kcmil	2	#1 ~ 500 kcmil
047	5	J	200	60						
			230	60						
			380	60	3	#2 - 600 kcmil	3	#3/0 ~ 400 kcmil	3	#3/0 ~ 400 kcmil
			400	50	3	#2 - 600 kcmil	3	#3/0 ~ 400 kcmil	3	#3/0 ~ 400 kcmil
			460	60	2	#2 - 600 kcmil	2	#1 ~ 500 kcmil	2	#1 ~ 500 kcmil
047	5	J	200	60						
			230	60						
			380	60	3	#2 - 600 kcmil	3	#3/0 ~ 400 kcmil	3	#3/0 ~ 400 kcmil
			400	50	3	#2 - 600 kcmil	3	#3/0 ~ 400 kcmil	3	#3/0 ~ 400 kcmil
			460	60	2	#2 - 600 kcmil	2	#1 ~ 500 kcmil	2	#1 ~ 500 kcmil

FIELD WIRING LUGS					HIGH AIRFLOW/HIGH STATIC CONDENSER FANS					
					TERMINAL BLOCK		CIRCUIT BREAKER		NON-FUSED DISCONNECT SWITCH	
YVAA MODEL			INPUT VOLTS	INPUT FREQ	WIRE PER PHASE	LUG WIRE RANGE	WIRES PER PHASE	LUG WIRE RANGE	WIRES PER PHASE	LUG WIRE RANGE
FRAME	COND	EVAP								
DUAL POINT WIRING										
036	8	J	200	60						
			230	60						
			380	60	3	#2 - 600 kcmil	3	#3/0 ~ 400 kcmil	3	#3/0 ~ 400 kcmil
			400	50	3	#2 - 600 kcmil	3	#3/0 ~ 400 kcmil	3	#3/0 ~ 400 kcmil
			460	60	2	#2 - 600 kcmil	3	#3/0 ~ 400 kcmil	3	#3/0 ~ 400 kcmil
			575	60	2	#2 - 600 kcmil	2	#1 ~ 500 kcmil	2	#1 ~ 500 kcmil
037	3	F	200	60						
			230	60						
			380	60	3	#2 - 600 kcmil	3	#3/0 ~ 400 kcmil	3	#3/0 ~ 400 kcmil
			400	50	3	#2 - 600 kcmil	3	#3/0 ~ 400 kcmil	3	#3/0 ~ 400 kcmil
			460	60	3	#2 - 600 kcmil	3	#3/0 ~ 400 kcmil	3	#3/0 ~ 400 kcmil
			575	60						
037	5	J	200	60						
			230	60						
			380	60	3	#2 - 600 kcmil	3	#3/0 ~ 400 kcmil	3	#3/0 ~ 400 kcmil
			400	50	3	#2 - 600 kcmil	3	#3/0 ~ 400 kcmil	3	#3/0 ~ 400 kcmil
			460	60	2	#2 - 600 kcmil	3	#3/0 ~ 400 kcmil	3	#3/0 ~ 400 kcmil
			575	60	2	#2 - 600 kcmil	2	#1 ~ 500 kcmil	2	#1 ~ 500 kcmil
039	8	J	200	60						
			230	60						
			380	60	3	#2 - 600 kcmil	3	#3/0 ~ 400 kcmil	3	#3/0 ~ 400 kcmil
			400	50	3	#2 - 600 kcmil	3	#3/0 ~ 400 kcmil	3	#3/0 ~ 400 kcmil
			460	60	2	#2 - 600 kcmil	3	#3/0 ~ 400 kcmil	3	#3/0 ~ 400 kcmil
			575	60	2	#2 - 600 kcmil	2	#1 ~ 500 kcmil	2	#1 ~ 500 kcmil
041	3	H	200	60						
			230	60						
			380	60	3	#2 - 600 kcmil	3	#3/0 ~ 400 kcmil	3	#3/0 ~ 400 kcmil
			400	50	3	#2 - 600 kcmil	3	#3/0 ~ 400 kcmil	3	#3/0 ~ 400 kcmil
			460	60	3	#2 - 600 kcmil	3	#3/0 ~ 400 kcmil	3	#3/0 ~ 400 kcmil
			575	60						
042	5	H	200	60						
			230	60						
			380	60	3	#2 - 600 kcmil	3	#3/0 ~ 400 kcmil	3	#3/0 ~ 400 kcmil
			400	50	3	#2 - 600 kcmil	3	#3/0 ~ 400 kcmil	3	#3/0 ~ 400 kcmil
			460	60	2	#2 - 600 kcmil	3	#3/0 ~ 400 kcmil	3	#3/0 ~ 400 kcmil
			575	60	2	#2 - 600 kcmil	2	#1 ~ 500 kcmil	2	#1 ~ 500 kcmil
042	8	J	200	60						
			230	60						
			380	60	3	#2 - 600 kcmil	3	#3/0 ~ 400 kcmil	3	#3/0 ~ 400 kcmil
			400	50	3	#2 - 600 kcmil	3	#3/0 ~ 400 kcmil	3	#3/0 ~ 400 kcmil
			460	60	2	#2 - 600 kcmil	3	#3/0 ~ 400 kcmil	3	#3/0 ~ 400 kcmil
			575	60	2	#2 - 600 kcmil	2	#1 ~ 500 kcmil	2	#1 ~ 500 kcmil
044	3	G	200	60						
			230	60						
			380	60	3	#2 - 600 kcmil	3	#3/0 ~ 400 kcmil	3	#3/0 ~ 400 kcmil
			400	50	3	#2 - 600 kcmil	3	#3/0 ~ 400 kcmil	3	#3/0 ~ 400 kcmil
			460	60	3	#2 - 600 kcmil	3	#3/0 ~ 400 kcmil	3	#3/0 ~ 400 kcmil
			575	60						
047	5	J	200	60						
			230	60						
			380	60	3	#2 - 600 kcmil	3	#3/0 ~ 400 kcmil	3	#3/0 ~ 400 kcmil
			400	50	3	#2 - 600 kcmil	3	#3/0 ~ 400 kcmil	3	#3/0 ~ 400 kcmil
			460	60	2	#2 - 600 kcmil	3	#3/0 ~ 400 kcmil	3	#3/0 ~ 400 kcmil
			575	60	2	#2 - 600 kcmil	2	#1 ~ 500 kcmil	2	#1 ~ 500 kcmil

FIELD WIRING LUGS					STANDARD & ULTRA QUIET CONDENSER FANS					
					TERMINAL BLOCK		CIRCUIT BREAKER		NON-FUSED DISCONNECT SWITCH	
YVAA MODEL			INPUT VOLTS	INPUT FREQ	WIRES PER PHASE	LUG WIRE RANGE	WIRES PER PHASE	LUG WIRE RANGE	WIRES PER PHASE	LUG WIRE RANGE
FRAME	COND	EVAP								
DUAL POINT WIRING										
048	3	G	200	60						
			230	60						
			380	60	3	#2 - 600 kcmil	3	#3/0 ~ 400 kcmil	3	#3/0 ~ 400 kcmil
			400	50	3	#2 - 600 kcmil	3	#3/0 ~ 400 kcmil	3	#3/0 ~ 400 kcmil
			460	60	2	#2 - 600 kcmil	2	#1 ~ 500 kcmil	2	#1 ~ 500 kcmil
050	0	J	200	60						
			230	60						
			380	60	3	#2 - 600 kcmil	3	#3/0 ~ 400 kcmil	3	#3/0 ~ 400 kcmil
			400	50	3	#2 - 600 kcmil	3	#3/0 ~ 400 kcmil	3	#3/0 ~ 400 kcmil
			460	60	2	#2 - 600 kcmil	2	#1 ~ 500 kcmil	2	#1 ~ 500 kcmil
052	3	J	200	60						
			230	60						
			380	60	3	#2 - 600 kcmil	3	#3/0 ~ 400 kcmil	3	#3/0 ~ 400 kcmil
			400	50	3	#2 - 600 kcmil	3	#3/0 ~ 400 kcmil	3	#3/0 ~ 400 kcmil
			460	60	2	#2 - 600 kcmil	2	#1 ~ 500 kcmil	2	#1 ~ 500 kcmil
			575	60	2	#2 - 600 kcmil	2	#1 ~ 500 kcmil	2	#1 ~ 500 kcmil

FIELD WIRING LUGS				TERMINAL BLOCK		TERMINAL BLOCK WITH INDEPENDENT SYSTEM CIRCUIT BREAKERS		TERMINAL BLOCK WITH INDEPENDENT SYSTEM NON-FUSED DISCONNECT SWITCHES		
YVAA MODEL			INPUT VOLTS	INPUT FREQ	WIRES PER PHASE	LUG WIRE RANGE	WIRES PER PHASE	LUG WIRE RANGE	WIRES PER PHASE	LUG WIRE RANGE
FRAME	COND	EVAP								
SINGLE POINT WIRING										
Models 0368 to 0523			200	60						
			230	60						
			380	60	4	#1 - 750 kcmil	4	#1 - 750 kcmil	4	#1 - 750 kcmil
			400	50	4	#1 - 750 kcmil	4	#1 - 750 kcmil	4	#1 - 750 kcmil
			460	60	4	#1 - 750 kcmil	4	#1 - 750 kcmil	4	#1 - 750 kcmil
			575	60	4	#1 - 750 kcmil	4	#1 - 750 kcmil	4	#1 - 750 kcmil

FIELD WIRING LUGS					HIGH AIRFLOW/HIGH STATIC CONDENSER FANS					
					TERMINAL BLOCK		CIRCUIT BREAKER		NON-FUSED DISCONNECT SWITCH	
YVAA MODEL			INPUT VOLTS	INPUT FREQ	WIRE PER PHASE	LUG WIRE RANGE	WIRES PER PHASE	LUG WIRE RANGE	WIRES PER PHASE	LUG WIRE RANGE
FRAME	COND	EVAP								
DUAL POINT WIRING										
048	3	G	200	60						
			230	60						
			380	60	3	#2 - 600 kcmil	3	#3/0 ~ 400 kcmil	3	#3/0 ~ 400 kcmil
			400	50	3	#2 - 600 kcmil	3	#3/0 ~ 400 kcmil	3	#3/0 ~ 400 kcmil
			460	60	3	#2 - 600 kcmil	3	#3/0 ~ 400 kcmil	3	#3/0 ~ 400 kcmil
			575	60						
050	0	J	200	60						
			230	60						
			380	60	3	#2 - 600 kcmil	3	#3/0 ~ 400 kcmil	3	#3/0 ~ 400 kcmil
			400	50	3	#2 - 600 kcmil	3	#3/0 ~ 400 kcmil	3	#3/0 ~ 400 kcmil
			460	60	3	#2 - 600 kcmil	3	#3/0 ~ 400 kcmil	3	#3/0 ~ 400 kcmil
			575	60						
052	3	J	200	60						
			230	60						
			380	60	3	#2 - 600 kcmil	3	#3/0 ~ 400 kcmil	3	#3/0 ~ 400 kcmil
			400	50	3	#2 - 600 kcmil	3	#3/0 ~ 400 kcmil	3	#3/0 ~ 400 kcmil
			460	60	3	#2 - 600 kcmil	3	#3/0 ~ 400 kcmil	3	#3/0 ~ 400 kcmil
			575	60						

Power Wiring

SINGLE POINT WIRING

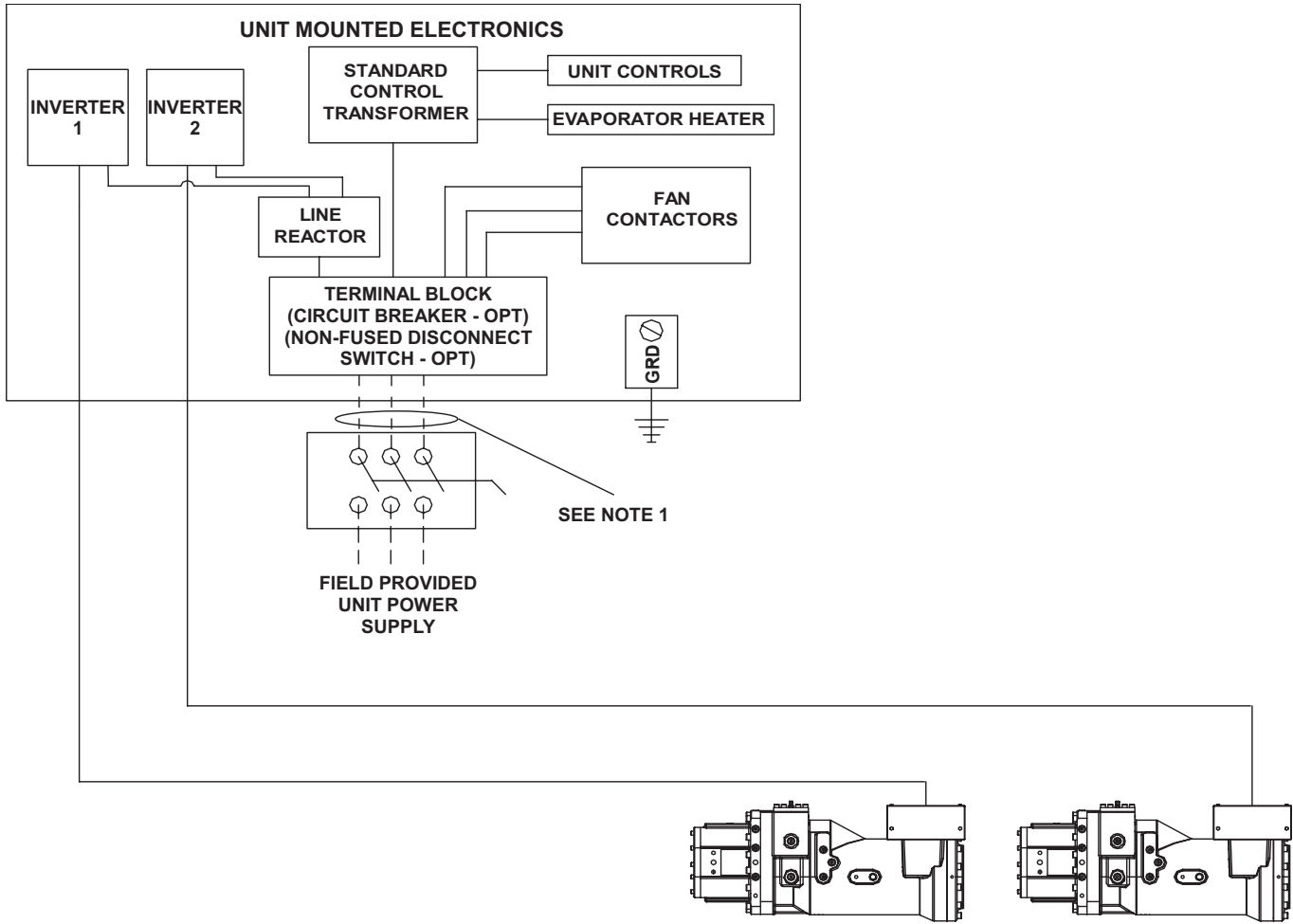



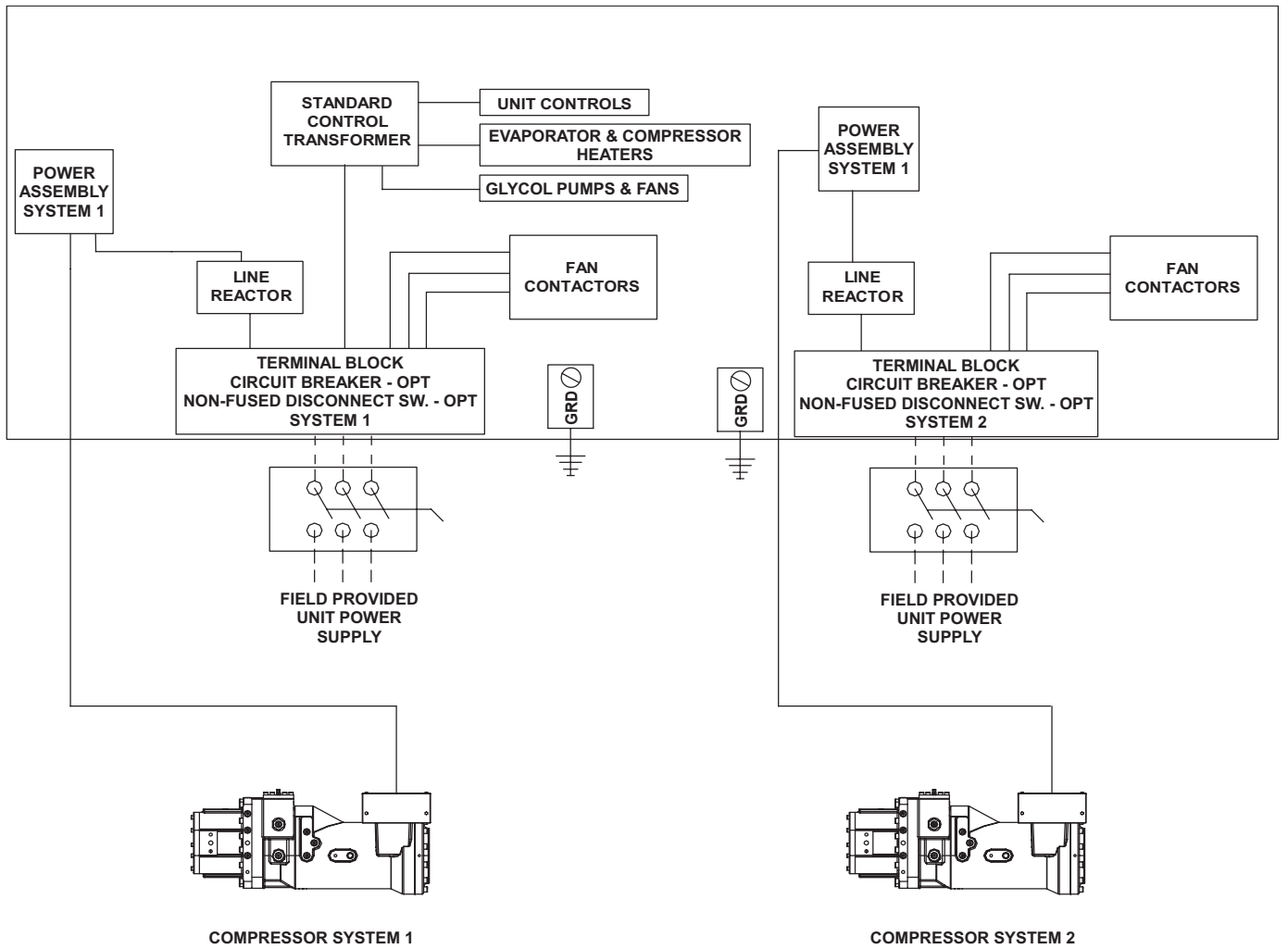

DUAL POINT WIRING

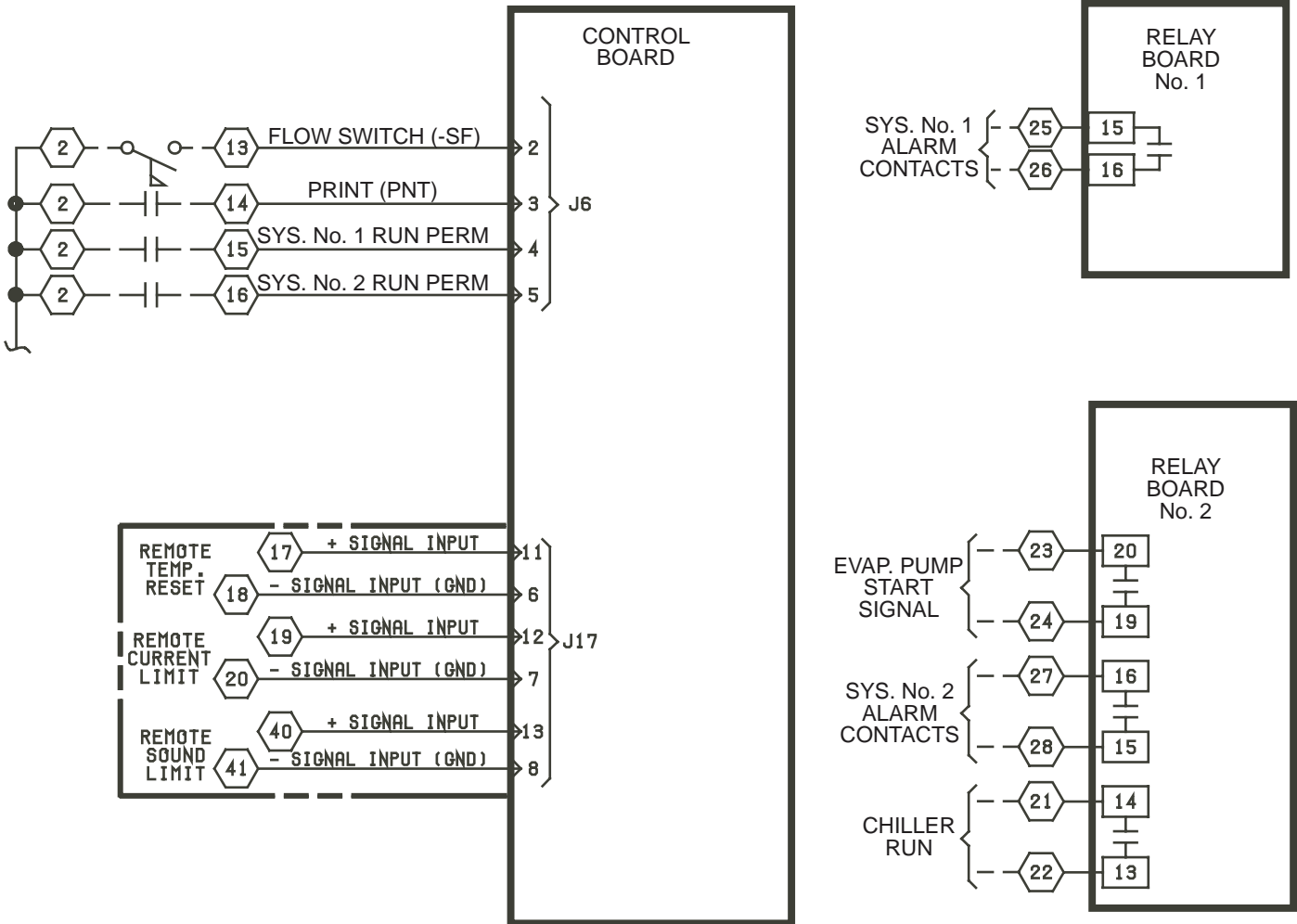

Customer Control Wiring



LEGEND

-  TERMINAL BLOCK FOR CUSTOMER CONNECTIONS
-  TERMINAL BLOCK FOR YORK CONNECTIONS
-  WIRING AND COMPONENTS BY YORK
-  OPTIONAL EQUIPMENT
-  WIRING AND/OR COMPONENTS BY OTHERS

INTENTIONALLY LEFT BLANK

Control Wiring

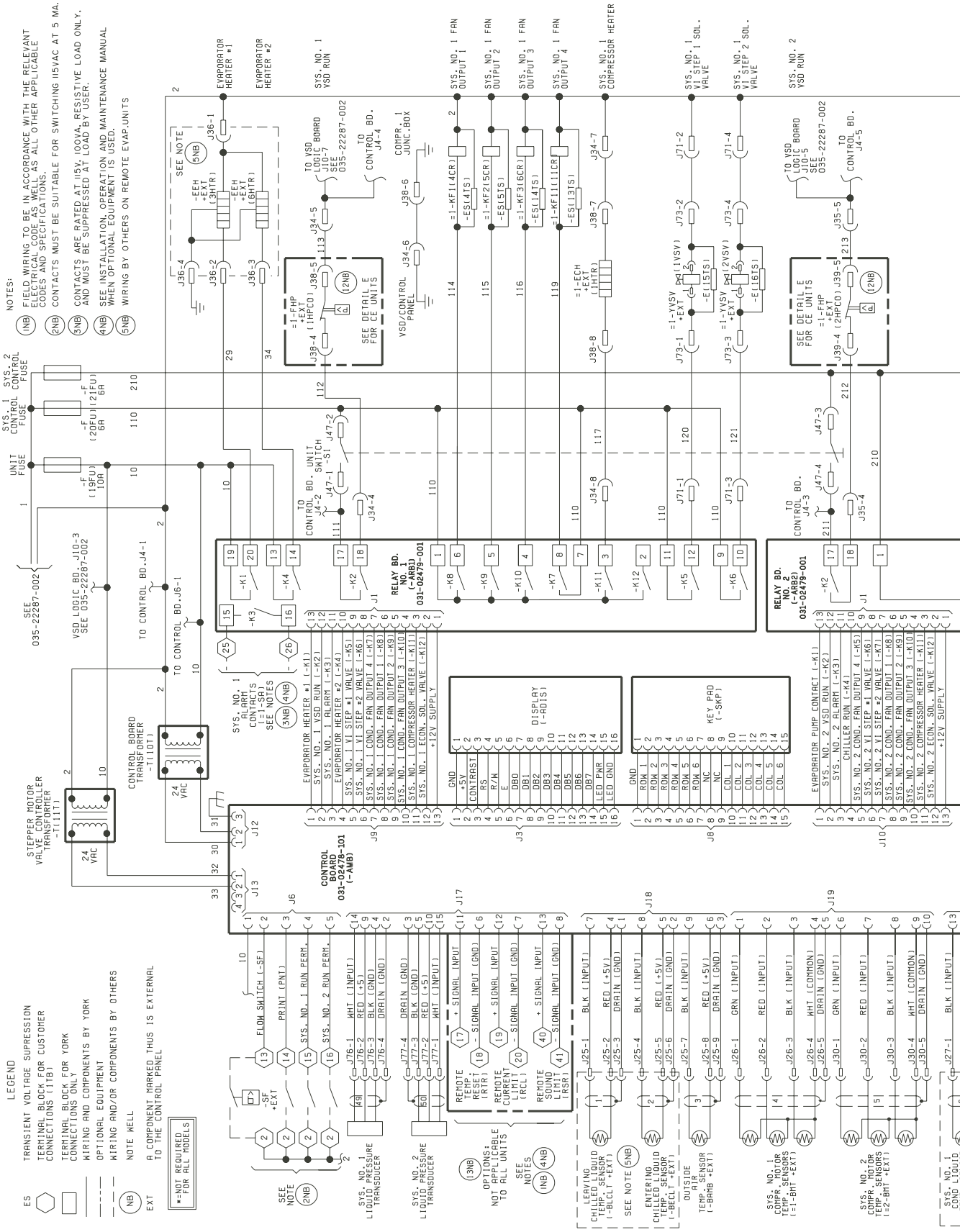

Guide Specifications

PART 1 - GENERAL

1.01 GENERAL REQUIREMENTS

The requirements of this Section shall conform to the general provisions of the Contract, including General and Supplementary Conditions, Conditions of the Contract, and Contract Drawings.

1.02 SCOPE

Provide Microprocessor controlled, twin-screw compressor, air-cooled, liquid chillers of the scheduled capacities as shown and indicated on the Drawings, including but not limited to:

1. Chiller package
2. Charge of refrigerant and oil
3. Electrical power and control connections
4. Chilled liquid connections
5. Manufacturer start-up

1.03 QUALITY ASSURANCE

A. Products shall be Designed, Tested, Rated and Certified in accordance with, and Installed in compliance with applicable sections of the following Standards and Codes:

1. AHRI 550/590 – Water Chilling Packages Using the Vapor Compression Cycle
2. AHRI 370 – Sound Rating of Large Outdoor Refrigerating and Air-Conditioning Equipment
3. ANSI/ASHRAE 15 – Safety Code for Mechanical Refrigeration
4. ANSI/ASHRAE 34 – Number Designation and Safety Classification of Refrigerants
5. ASHRAE 90.1 – Energy Standard for Buildings Except Low-Rise Residential Buildings
6. ANSI/NFPA 70 – National Electrical Code (N.E.C.)
7. ASME Boiler and Pressure Vessel Code, Section VIII, Division 1
8. OSHA – Occupational Safety and Health Act
9. Manufactured in facility registered to ISO 9001
10. Conform to Intertek Testing Services for construction of chillers and provide ETL/cETL Listed Mark

B. Factory Run Test: Chiller shall be pressure-tested, evacuated and fully charged with refrigerant and oil, and shall be factory operational run tested with water flowing through the vessel.

C. Chiller manufacturer shall have a factory trained and supported service organization.

- D. Warranty: Manufacturer shall Warrant all equipment and material of its manufacture against defects in workmanship and/or material for a period of eighteen (18) months from date of shipment or twelve (12) months from date of start-up, whichever occurs first.

1.04 DELIVERY AND HANDLING

- A. Unit shall be delivered to job site fully assembled with all interconnecting refrigerant piping and internal wiring ready for field installation and charged with refrigerant and oil by the Manufacturer.
- B. Provide protective covering over vulnerable components for unit protection during shipment. Fit nozzles and open ends with plastic enclosures.
- C. Unit shall be stored and handled per Manufacturer's instructions.

PART 2 - PRODUCTS

2.01 MANUFACTURERS

- A. The design shown on the Drawings is based on YORK model YVAA chiller manufactured by Johnson Controls / YORK. Alternate equipment will be acceptable if the manufacturer's equipment meets the scheduled performance and complies with these specifications. If equipment manufactured by a manufacturer other than that scheduled is utilized, then the Mechanical Contractor shall be responsible for coordinating with the General Contractor and all affected Subcontractors to insure proper provisions for installation of the furnished unit. This coordination shall include, but not be limited to, the following:
1. Structural supports for units.
 2. Piping size and connection/header locations.
 3. Electrical power requirements and wire/conduit and overcurrent protection sizes.
 4. Chiller physical size on plant layout.
 5. Site noise considerations.
- B. The Mechanical Contractor shall be responsible for all costs incurred by the General Contractor, Subcontractors, and Consultants to modify the building provisions to accept the furnished alternate equipment.

2.02 GENERAL

- A. Description: Furnish, Install, and Commission factory assembled, charged, and operational run tested air-cooled screw compressor chiller as specified herein and shown on the Drawings. Chiller shall include, but is not limited to: a complete system with multiple independent refrigerant circuits, semi hermetic twin screw compressors, shell and tube hybrid falling film type evaporator, air-cooled condenser, R134a refrigerant, lubrication system, interconnecting wiring, safety and operating controls including capacity controller, control center, motor starting components, and special features as specified herein or required for safe, automatic operation.
- B. Operating Characteristics:
1. Provide low and high ambient temperature control options as required to ensure unit is capable of operation from 0°F to 125°F (-18°C to 52°C) ambient temperature.

2. Provide capacity control system capable of reducing unit capacity to 10% of full load for 2 compressor units. Compressor shall start in unloaded condition. Application of factory installed hot gas bypass shall be acceptable as required to meet specified minimum load.
- C. Cabinet: Unit panels, structural elements, control boxes and heavy gauge structural base shall be constructed of painted galvanized steel. All exposed sheet steel shall be coated with baked on powder paint to meet 500-hour salt spray test in accordance with the ASTM B117 standard.
- D. Shipping: Unit shall ship in one piece and shall require installer to provide only a single evaporator inlet and outlet pipe connection. If providing chiller model that ships in multiple pieces, bid shall include all the material and field labor costs for factory authorized personnel to install a trim kit to connect the pieces as well as all interconnecting piping and wiring.

2.03 COMPRESSORS

- A. Compressors: Shall be direct drive, semi hermetic, rotary twin-screw type, including: muffler, temperature actuated 'off-cycle' heater, rain-tight terminal box, discharge shut-off service valve, and precision machined cast iron housing. Design working pressure of entire compressor, suction to discharge, shall be 350 psig (24 barg) or higher. Compressor shall be U.L. Recognized.
- [OPTIONAL]:** Suction shut-off service valve for each compressor.
- B. Compressor Motors: Refrigerant suction-gas cooled accessible hermetic compressor motor, full suction gas flow through 0.006" (0.1524 mm) maximum mesh screen, with inherent internal thermal overload protection and external current overload on all three phases.
- C. Balancing Requirements: All rotating parts shall be statically and dynamically balanced.
- D. Lubrication System: External oil separators with no moving parts, 450 psig (31 barg) design working pressure, and ETL listing shall be provided on the chiller. Refrigerant system differential pressure shall provide oil flow through service replaceable, 0.5 micron, full flow, cartridge type oil filter internal to compressor. Filter bypass, less restrictive media, or oil pump not acceptable.
- E. Capacity Control: Compressors shall start at minimum load. Provide Microprocessor control to command compressor capacity to balance compressor capacity with cooling load.

2.04 REFRIGERANT CIRCUIT COMPONENTS

- A. Refrigerant: R-134a. Classified as Safety Group A1 according to ASHRAE 34
- B. Equipment supplied shall comply with LEED Energy & Atmosphere Credit 4, Enhanced Refrigerant Management.
- C. Each independent refrigerant circuit shall incorporate all components necessary for the designed operation including: liquid line shut-off valve with charging port, low side pressure relief device, removable core filter-drier and sight glass with moisture indicator.
- D. Chiller manufacturer shall provide an independent circuit for each compressor to provide maximum redundancy during chiller operation. If equipment does not have independent circuits per compressor, manufacturer shall provide owner one spare compressor of each unique size.

E. Discharge lines shall be provided with manual compressor shut-off service valves.

2.05 HEAT EXCHANGERS

A. Evaporator:

1. Evaporator shall be shell and tube, hybrid falling film type to optimize efficiency and refrigerant charge. Tubes shall be high-efficiency, internally and externally enhanced type copper tubes with 0.035" (0.89 mm) minimum wall thickness at all intermediate tube supports to provide maximum tube wall thickness at the support area. Each tube shall be roller expanded into the tube sheets providing a leak proof seal, and be individually replaceable. Independent refrigerant circuits shall be provided per compressor.

[OPTIONAL]: 3 pass arrangement.

2. Constructed, tested, and stamped in accordance with applicable sections of ASME pressure vessel code for minimum 235 psig (16 barg) refrigerant side design working pressure and 150 psig (10 barg) liquid side design working pressure.
3. Water boxes shall be removable to permit tube cleaning and replacement. Water boxes shall include liquid nozzle connections suitable for ANSI/AWWA C-606 couplings, welding, or flanges.

[OPTIONAL]: 150 psig (10.3 barg) ANSI raised-face weldable flanges. Flanges are field-welded by Contractor. Companion flanges, bolts, nuts, and gaskets are not included.

[OPTIONAL]: 150 psig (10.3 barg) ANSI raised-face flanges with ANSI/AWWA C-606 couplings. Flanges are field-mounted by Contractor. Companion flanges, bolts, nuts, and gaskets are not included.

[OPTIONAL]: 150 psig (10.3 barg) ANSI raised-face weldable flanges with companion flanges. Flanges are field-welded by Contractor. Bolts, nuts, and gaskets are not included.

[OPTIONAL]: 150 psig (10.3 barg) ANSI raised-face flanges with ANSI/AWWA C-606 couplings with companion flanges. Flanges are field-mounted by Contractor. Bolts, nuts, and gaskets are not included.

4. Provide vent and drain fittings, and thermo-statically controlled heaters to protect to 0°F (-17.8°C) ambient temperature in off-cycle.

[OPTIONAL]: Provide freeze protection down to -20°F (-28°C) ambient temperature. A separate power connection for evaporator heaters is required and shall be provided by the Contractor.

5. Connection location: Chilled liquid inlet and outlet nozzle connections are located at rear (opposite control panel) end of unit.

[OPTIONAL]: Inlet and outlet nozzle connections located at front end of unit. Available for select configurations.

B. Air-cooled Condenser:

1. Condenser coils shall be microchannel type, parallel flow aluminum alloy tubes metallurgically brazed as one piece to enhanced aluminum alloy fins. Condenser coils shall be made of a single material to avoid galvanic corrosion due to dissimilar metals. Tube and fin type condenser coils are an acceptable alternate when tubes and fins are fabricated of the same metal material to avoid galvanic corrosion due to dissimilar metals. Coils shall be designed for 350 psig (24 barg) or higher working pressure.

[**OPTIONAL**]: Coils, internally enhanced, seamless copper tubes, mechanically expanded into aluminum alloy fins with full height collars. Subcooling coil an integral part of condenser. Design working pressure shall be 350 PSIG (24 barg).

[**OPTIONAL**]: Post-coated epoxy dipped condenser microchannel: The unit shall be built with microchannel sections that have been applied with an electro-deposited and baked flexible epoxy coating that is finished with a polyurethane UV resistant top-coat suitable for highly corrosive applications.

[**OPTIONAL**]: Wire Panels: Heavy gauge, welded wire mesh coated to resist corrosion, to protect condenser coils from incidental damage and also restrict unauthorized access to internal components.

[**OPTIONAL**]: Louvered Panels (Condenser Coils): Painted steel to match unit panels, over external condenser coil faces.

[**OPTIONAL**]: Louvered Panels (Full Unit): Painted steel to match unit panels, over internal components.

[**OPTIONAL**]: Louvered/Wire Panels: Louvered steel panels on external condenser coil faces, painted to match unit panels. Heavy gauge, welded wire mesh, coated to resist corrosion, around base of machine to restrict unauthorized access.

[**OPTIONAL**]: End Hail Guard: Louvered steel panels on rear of unit (opposite end of control panel), painted to match unit panels.

[**OPTIONAL**]: V-Guard Panels: Steel panels installed over exposed condenser piping to protect from damage.

2. Low Sound Fans: Shall provide vertical air discharge from extended orifices. Fans shall be composed of corrosion resistant aluminum hub and glass-fiber-reinforced polypropylene composite blades molded into a low-noise airfoil section. Fan impeller shall be dynamically balanced for vibration-free operation. Fan guards of heavy gauge, PVC (polyvinyl chloride) coated or galvanized steel.

[**OPTIONAL**]: Ultra-Quiet Fans

[**OPTIONAL**]: High Airflow Fans

[**OPTIONAL**]: High Static Fans

3. Fan Motors: High efficiency, direct drive, 3-phase, insulation class "F", current protected, Totally Enclosed Air-Over (TEAO), with double sealed, permanently-lubricated ball bearings. Open Drip Proof (ODP) fan motors will not be acceptable.

2.06 INSULATION

- A. Material: Closed-cell, flexible, UV protected, thermal insulation complying with ASTM C 534 Type 2 (Sheet) for preformed flexible elastomeric cellular thermal insulation in sheet and tubular form.

Thickness: 3/4" (19mm.)

[**OPTIONAL**]: 1-1/2" (38mm.)

- B. Thermal conductivity: 0.26 (BTU/HR-Ft²-°F/in) maximum at 75°F mean temperature.
- C. Factory-applied insulation over cold surfaces of liquid chiller components including evaporator shell, water boxes, and suction line. Liquid nozzles shall be insulated by Contractor after pipe installation.
- D. Adhesive: As recommended by insulation manufacturer and applied to 100 percent of insulation contact surface including all seams and joints.

2.07 ACOUSTICAL DATA

- A. Provide acoustical sound power or sound pressure level data in decibels (dB) at the scheduled eight (8) octave band center frequencies. A-weighted sound data alone is not acceptable.
- B. Provide all sound power or sound pressure level data at 100%, 75%, 50%, and 25% load.
- C. Supplied equipment shall not exceed scheduled sound power or sound pressure level data at any load point. The mechanical Contractor shall be responsible for any additional costs associated with equipment deviation.
- D. Acoustical performance ratings shall be in accordance with AHRI Standard 370

[OPTIONAL]: Provide factory-installed sound reduction enclosures and ultra-quiet fans to meet chiller sound levels scheduled at all load points.

[OPTIONAL]: Provide optional control input to limit sound output of the chiller based on time of day. Shall be programmable at the chiller panel or controlled remotely via signal (4-20 mA or 0-10VDC) from BAS system. Chillers without this feature shall be provided with the necessary sound attenuation to meet the scheduled sound performance data at all load points.

2.08 POWER AND ELECTRICAL REQUIREMENTS

A. Power/Control Panel:

- 1. Factory installed and wired NEMA 3R, powder painted steel cabinets with tool lockable, hinged, latched, and gasket sealed outer doors equipped with wind struts for safer servicing. Provide main power connection(s), compressor starters and fan motor contactors, current overloads, and factory wiring.
- 2. Panel shall include control display access door.

B. Single Point Power:

- 1. Provide single point power connection to chiller, shall be 3 phase of scheduled voltage.
- 2. Terminal Block connections shall be provided at the point of incoming single point connection for field connection and interconnecting wiring to the compressors. Separate external protection must be supplied, by others, in the incoming power wiring, which must comply with local codes.

[OPTIONAL]: Single Point Disconnect: A non-fused disconnect and lockable external handle shall be supplied to isolate the unit power voltage for servicing. Separate external fusing must be supplied, by others, in the incoming power wiring which must comply with local codes.

[OPTIONAL]: Single Point Circuit Breaker: A unit-mounted Circuit Breaker with external lockable handle shall be supplied to isolate power voltage for servicing. Incoming power wiring must comply with local codes. Circuit breaker shall be sized to provide the motor branch circuit protection, short circuit protection and ground fault protection for the motor branch-circuit conductors, the motor control apparatus and the motors.

- C. Control Transformer: Power panel shall be supplied with a factory mounted and wired control transformer that will supply all unit control voltage from the main unit power supply. Transformer shall utilize scheduled line voltage on the primary side and provide 115V/1Ø on secondary.

- D. Short Circuit Withstand Rating of the chiller electrical enclosure shall be (380, 400, & 460V: minimum of 30,000 Amps [OR 65,000 Amps for Single Point Circuit Breaker].) Rating shall be published in accordance with UL508.
- E. Motor Starters: Motor starters shall be zero electrical inrush current (Variable Frequency Drives) or reduced inrush type (Closed transition Wye-Delta or Solid State) for minimum electrical inrush. Open transition Wye-Delta and Across the Line type starters will not be acceptable.
- F. Power Factor:
1. Provide equipment with power factor correction capacitors as required to maintain a displacement power factor of 95% at all load conditions.
 2. The installing contractor is responsible for additional cost to furnish and install power factor correction capacitors if they are not factory mounted and wired.
- G. All exposed power wiring shall be routed through liquid-tight, UV-stabilized, non-metallic conduit.
- H. Supplied equipment shall not exceed scheduled Minimum Circuit Ampacity (MCA.) The mechanical Contractor shall be responsible for any additional costs associated with equipment deviation.

2.09 CONTROLS

A. General:

1. Provide automatic control of chiller operation including compressor start/stop and load/unload, anti-recycle timers, condenser fans, evaporator pump, evaporator heater, unit alarm contacts and run signal contacts.
2. Chiller shall automatically reset to normal chiller operation after power failure.
3. Unit operating software shall be stored in non-volatile memory. Field programmed set points shall be retained in lithium battery backed regulated time clock (RTC) memory for minimum 5 years.
4. Alarm contacts shall be provided to remote alert for any unit or system safety fault.

B. Display and Keypad:

1. Provide minimum 80 character liquid crystal display that is both viewable in direct sunlight and has LED backlighting for nighttime viewing. Provide one keypad and display panel per chiller.
2. Display and keypad shall be accessible through display access door without opening main control/electrical cabinet doors.
3. Display shall provide a minimum of unit setpoints, status, electrical data, temperature data, pressures, safety lockouts and diagnostics without the use of a coded display.
4. Descriptions in English (or available language options), numeric data in English (or Metric) units.
5. Sealed keypad shall include unit On/Off switch.

- C. Programmable Setpoints (within Manufacturer limits): Display language, chilled liquid cooling mode, local/remote control mode, display units mode, system lead/lag control mode, remote temperature reset, remote current limit, remote sound limit, low ambient temperature cutout enable/disable, leaving chilled liquid setpoint and range, maximum remote temperature reset.

- D. Display Data: Chilled liquid leaving and entering temperatures; outside ambient air temperature; lead system; evaporator pump status; active remote control; compressor suction, discharge, and oil pressures per refrigerant circuit; compressor discharge, motor, and oil temperatures per refrigerant circuit; saturation temperatures per refrigerant circuit; compressor speed; condenser fan status; condenser subcooling temperature; condenser drain valve percentage open; compressor capacity in percentage of Full Load Amps; compressor number of starts; run time; operating hours; evaporator heater status; history data for last ten shutdown faults; history data for last 20 normal (non-fault) shutdowns.
- E. Predictive Control Points: Unit controls shall avoid safety shutdown when operating outside design conditions by optimizing the chiller controls and cooling load output to stay online and avoid safety limits being reached. The system shall monitor the following parameters and maintain the maximum cooling output possible without shutdown of the equipment: motor current, suction pressure, discharge pressure, starter internal ambient temperature, and starter baseplate temperature.
- F. System Safeties: Shall cause individual compressor systems to perform auto-reset shut down if: high discharge pressure or temperature, low suction pressure, low motor current, high/low differential oil pressure, low discharge superheat, high motor temperature, system control voltage.
- G. Unit Safeties: Shall be automatic reset and cause compressors to shut down if: high or low ambient temperature, low leaving chilled liquid temperature, under voltage, flow switch operation. Contractor shall provide flow switch and wiring per chiller manufacturer requirements.
- H. Manufacturer shall provide any controls not listed above, necessary for automatic chiller operation. Mechanical Contractor shall provide field control wiring necessary to interface sensors to the chiller control system.

2.10 ACCESSORIES AND OPTIONS

Some accessories and options supersede standard product features. All options are factory-mounted unless otherwise noted.

A. CONTROLS OPTIONS:

1. Building Automation System Interface: Chiller to accept 4 to 20mA or 0 to 10 VDC input from BAS (by others) to reset the leaving chilled liquid temperature or load limit setpoint or both.
2. Gateway: Provides communication for Building Automation Systems, including BACnet (MS/TP), Modbus, N2, and LON. (Field Commissioned by BAS Manufacturer)
3. Thermal Storage: Provide special control logic and modifications to produce leaving chilled brine temperatures below 40°F (4.4°C.)

B. GENERAL OPTIONS:

1. Flow Switch: Vapor proof SPDT, NEMA 3R switch, 150 psig (10.3 barg), -20°F to 250°F (-28.9°C to 121.1°C.) (Field Mounted by Contractor)
2. Differential Pressure Switch: 3-45 psig (0.2-3 barg) range with 1/4" NPTE pressure connections. (Field Mounted by Contractor)
3. Chicago Code Relief Valve – Special relief valves per Chicago Code
4. Special Requirement Documents:
 - a. Special Requirement Document Package (SRDP) includes Pressure Vessel

Report, Unit Run Test Report, Production System Check Sheet and Final Unit Inspection Check Sheet.

- b. Materials Package includes steel mill material reports for vessels in addition to Pressure Vessel Report, Unit Run Test Report, Production System Check Sheet and Final Unit Inspection Check Sheet.
5. Vibration Isolation (All Options Field Mounted by Contractor):
- a. Elastomeric Isolators.
 - b. 1" Deflection Spring Isolators: Level adjustable, spring and cage type isolators for mounting under the unit base rails.
 - c. 2" Deflection Restrained Spring Isolators: Level adjustable, restrained mounts in rugged welded steel housing with vertical and horizontal limit stops. Housings shall be designed to withstand a minimum 1.0g accelerated force in all directions to 2" (50.8 mm.)

PART 3 - EXECUTION

3.01 INSTALLATION

- A. General: Rig and Install in full accordance with Manufacturer's requirements, Project drawings, and Contract documents.
- B. Location: Locate chiller as indicated on drawings, including cleaning and service maintenance clearance per Manufacturer instructions. Adjust and level chiller on support structure.
- C. Components: Installing Contractor shall provide and install all auxiliary devices and accessories for fully operational chiller.
- D. Electrical: Coordinate electrical requirements and connections for all power feeds with Electrical Contractor.
- E. Controls: Coordinate all control requirements and connections with Controls Contractor.
- F. Finish: Installing Contractor shall paint damaged and abraded factory finish with touch-up paint matching factory finish.

Printed on recycled paper

Form 201.28-EG1 (514) Supersedes: 201.28-EG1 (1113)
© 2014 Johnson Controls, Inc. P.O. Box 423, Milwaukee, WI 53201 Printed in USA
www.johnsoncontrols.com
Issued on 03/21/2014

