



AIR-COOLED SCREW LIQUID CHILLERS

WIRING DIAGRAM

New Release

Form 201.21-W1 (405)



LATITUDE™

AIR-COOLED SCREW LIQUID CHILLERS STYLE A



LD10477



Metric Conversions

MODELS

YCAV0157-0267, 60 HZ
(150-260 TONS)

E/V HIGH EFFICIENCY AND S/P STANDARD EFFICIENCY

TABLE OF CONTENTS

	<u>PAGE</u>
NOMENCLATURE	3
ELECTRICAL NOTES	4
ELECTRICAL DATA	6
High Efficiency	6
Standard Efficiency.....	8
ELECTRICAL WIRING	10
Control Wiring Diagram	10
Power Wiring Diagram	12
Connection Wiring Diagram.....	14
HARNESS LOCATIONS	18
POWER AND ELECTRICAL REQUIREMENTS.....	19

LIST OF FIGURES

	<u>PAGE</u>
FIG. 1 – SINGLE-POINT POWER SUPPLY CONNECTION WITH FIELD SUPPLIED CIRCUIT PROTECTION.....	5
FIG. 2 – SINGLE-POINT POWER SUPPLY CONNECTION WITH OPTIONAL FACTORY CIRCUIT BREAKER	5
FIG. 3 – ELEMENTARY CONTROL WIRING DIAGRAM.....	10
FIG. 4 – ELEMENTARY POWER WIRING DIAGRAM	12
FIG. 5 – ELEMENTARY CONNECTION DIAGRAM	14
FIG. 6 – CONNECTION WIRING DIAGRAM.....	16
FIG. 7 – HARNESS LOCATIONS	18

UNIT MODEL NUMBER NOMENCLATURE

NOMENCLATURE

The model number denotes the following characteristics of the unit.

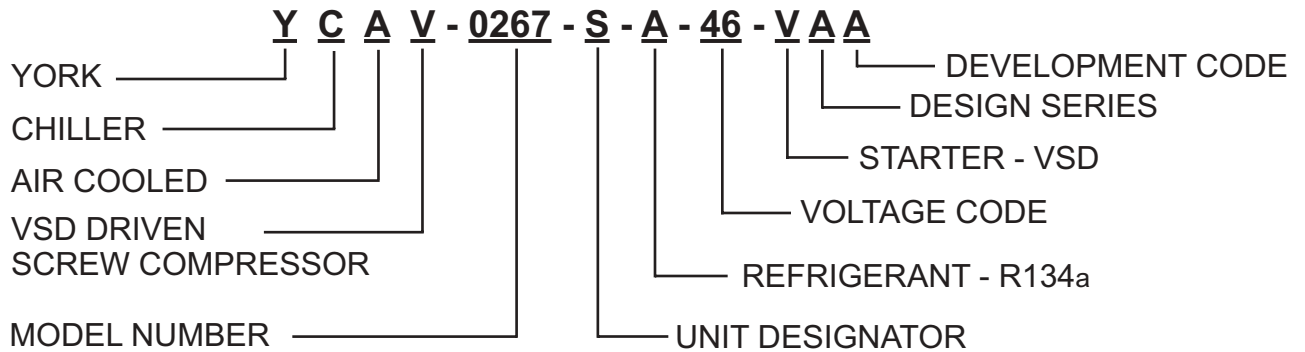

UNIT DESIGNATOR

- E- High Efficiency with Standard IPLV
- S- Standard Efficiency with Standard IPLV
- P- Standard Efficiency with High IPLV
- V- High Efficiency with High IPLV

VOLTAGE CODE

- 17=200-3-60
- 28=230-3-60
- 40=380-3-60
- 46=460-3-60
- 50=380/400/415-3-60
- 58=575-3-60

WARNING

HIGH VOLTAGE

is used in the operation of this equipment.

DEATH OR SERIOUS INJURY

may result if personnel fail to observe safety precautions.

Work on electronic equipment should not be undertaken unless the individual(s) have been trained in the proper maintenance of equipment and is (are) familiar with its potential hazards.

Shut off power supply to equipment before beginning work and follow lockout procedures. When working inside equipment with power off, take care to discharge every capacitor likely to hold dangerous potential.

Be careful not to contact high voltage connections when installing or operating this equipment.

LOW VOLTAGE

DO NOT be misled by the term "low voltage".
 Voltages as low as 50 volts may cause death.

ELECTRICAL NOTES

1. As standard, all units have single point power connection. Contact factory for information regarding dual point power units.
2. Maximum Inverse Time Circuit Breaker - 250% of the rated input current of the drive per NEC 430.52 (C1).
3. Maximum Dual Element (Time Delay) Fuse - 225% of the rated input current of the drive per NEC 430.52 (C1).
4. MCA - Minimum Circuit Ampacity - 125% of the largest compressor RLA plus 100% of the remaining compressor RLA's plus the sum of all condenser fan FLA's per NEC 440.33
5. Recommended time delay or dual element fuse size - 150% of the largest compressor RLA plus 100% of the remaining compressor RLA's plus the sum of all condenser fan FLA's.
6. RLA - Rated Load Amps - rated in accordance with UL standard 1995.
7. Local codes may take precedence.
8. Control KVA includes operational controls and evaporator heaters.
9. System inrush current is less than RLA due to the use of YORK Variable Speed Drive technology. Typical Compressor Starting Current

(.rst four seconds of startup):

Rated Voltage	Typical Starting Current per Compressor
200/60/3	53A
230/60/3	46A
380/60/3	29A
460/60/3	23A
575/60/3	18A

10. Optional Compressor Service Disconnect switch is available on all units.

11. Voltage Utilization Range:

Rated Voltage	Utilization Range
200/60/3	180-220
230/60/3	208-254
380/60/3	342-402
460/60/3	414-508
575/60/3	520-635

12. Condenser fan FLA applies to both low sound and ultra quiet fans.

LEGEND:

C.B.	CIRCUIT BREAKER
D.E.	DUAL ELEMENT FUSE
DISC SW	DISCONNECT SWITCH
FACT CB	FACTORY-MOUNTED CIRCUIT BREAKER
FLA	FULL LOAD AMPS
HZ	HERTZ
MAX	MAXIMUM
MCA	MINIMUM CIRCUIT AMPACITY
MIN	MINIMUM
MIN NF	MINIMUM NON-FUSED
RLA	RATED LOAD AMPS
S.P. WIRE	SINGLE-POINT WIRING

NOTES:

1. U.L. Label is provided on 60 Hz units for these electrical wiring configurations.
2. — — — — — Dashed Line = Field Provided Wiring.
3. The above recommendations are based on the National Electric Code and using copper conductors only. Field wiring must also comply with local codes.
Group Rated breaker must be HACR type for cUL machines.

2 COMPRESSOR POWER WIRING CONNECTIONS

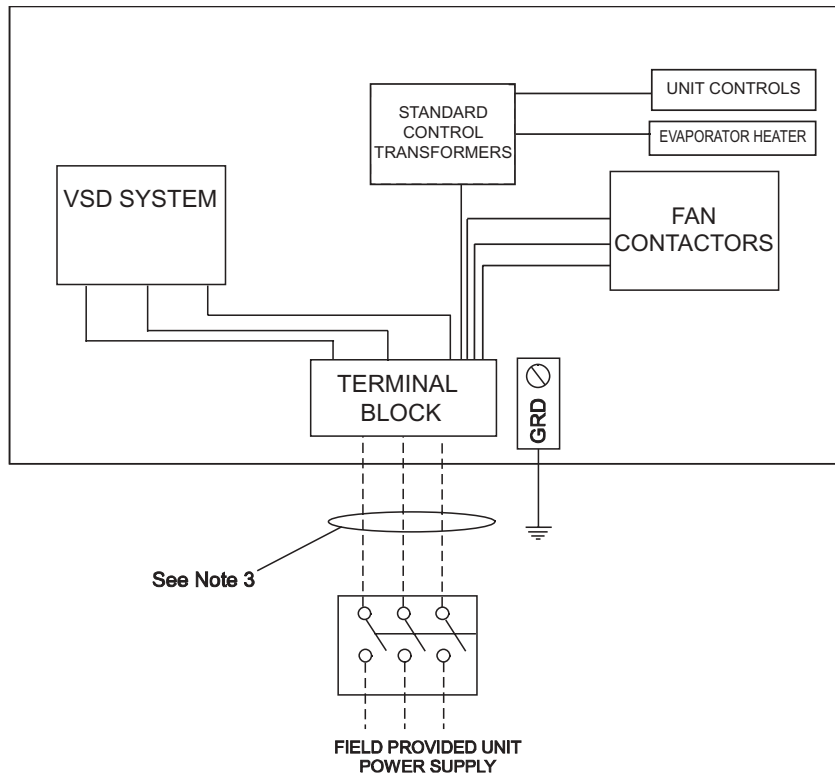

LD10598

FIG. 1 - SINGLE-POINT POWER SUPPLY CONNECTION WITH FIELD SUPPLIED CIRCUIT PROTECTION

VSD CONTROL PANEL

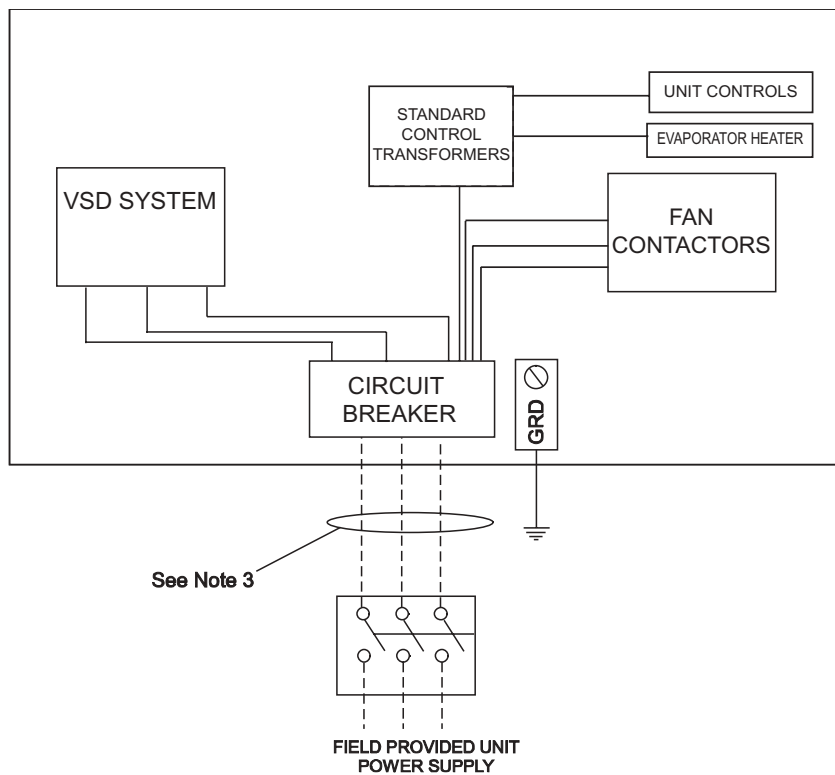

LD10599

FIG. 2 - SINGLE-POINT POWER SUPPLY CONNECTION WITH OPTIONAL FACTORY CIRCUIT BREAKER

ELECTRICAL DATA HIGH EFFICIENCY 2-Compressor Units

(One Field Provided Power Supply Circuit to the Chiller.
Field Connection to Factory provided Terminal Block (Standard)
or Circuit Breaker (optional).)

Model Number /Nameplate			System 1			System 2			Control KVA ⁸	Unit Short Circuit Withstand (KA)	
			Compressor	Cond. Fans		Compressor	Cond. Fans			Terminal Block (STD)	Circuit Breaker (OPT)
YCAV	Input Volts	Input Freq	RLA ⁶	Qty	FLA (EA)	RLA ⁶	Qty	FLA (EA)			
0157	200	60	254	4	6.5	254	4	6.5	1.8	30KA	100KA
	230	60	220	4	5.6	220	4	5.6	1.8	30KA	100KA
	380	60	139	4	3.5	139	4	3.5	1.8	30KA	65KA
	460	60	110	4	2.8	110	4	2.8	1.8	30KA	65KA
	575	60	88	4	2.2	88	4	2.2	1.8	30KA	42KA
0177	200	60	257	5	6.5	281	4	6.5	1.8	30KA	100KA
	230	60	223	5	5.6	244	4	5.6	1.8	30KA	100KA
	380	60	140	5	3.5	154	4	3.5	1.8	30KA	65KA
	460	60	111	5	2.8	122	4	2.8	1.8	30KA	65KA
	575	60	89	5	2.2	97	4	2.2	1.8	30KA	42KA
0187	200	60	356	5	6.5	242	5	6.5	1.8	30KA	100KA
	230	60	308	5	5.6	210	5	5.6	1.8	30KA	100KA
	380	60	194	5	3.5	132	5	3.5	1.8	30KA	65KA
	460	60	154	5	2.8	105	5	2.8	1.8	30KA	65KA
	575	60	123	5	2.2	84	5	2.2	1.8	30KA	42KA
0197	200	60	326	5	6.5	326	5	6.5	1.8	30KA	100KA
	230	60	283	5	5.6	283	5	5.6	1.8	30KA	100KA
	380	60	178	5	3.5	178	5	3.5	1.8	30KA	65KA
	460	60	141	5	2.8	141	5	2.8	1.8	30KA	65KA
	575	60	113	5	2.2	113	5	2.2	1.8	30KA	42KA
0207	200	60	327	6	6.5	353	5	6.5	1.8	30KA	100KA
	230	60	283	6	5.6	306	5	5.6	1.8	30KA	100KA
	380	60	178	6	3.5	193	5	3.5	1.8	30KA	65KA
	460	60	141	6	2.8	152	5	2.8	1.8	30KA	65KA
	575	60	113	6	2.2	122	5	2.2	1.8	30KA	42KA
0227	200	60	347	6	6.5	347	6	6.5	1.8	30KA	100KA
	230	60	301	6	5.6	301	6	5.6	1.8	30KA	100KA
	380	60	190	6	3.5	190	6	3.5	1.8	30KA	65KA
	460	60	150	6	2.8	150	6	2.8	1.8	30KA	65KA
	575	60	120	6	2.2	120	6	2.2	1.8	30KA	42KA
0247	200	60	449	6	6.5	344	6	6.5	1.8	30KA	100KA
	230	60	389	6	5.6	298	6	5.6	1.8	30KA	100KA
	380	60	245	6	3.5	188	6	3.5	1.8	30KA	65KA
	460	60	193	6	2.8	148	6	2.8	1.8	30KA	65KA
	575	60	155	6	2.2	119	6	2.2	1.8	30KA	42KA

ELECTRICAL DATA (CONT'D)

HIGH EFFICIENCY 2-Compressor Units (Con't)

(One Field Provided Power Supply Circuit to the Chiller.
Field Connection to Factory provided Terminal Block (Standard)
or Circuit Breaker (optional).)

YCAV	Field Wiring & Protection				Field Wiring Lugs		Field Wiring Lugs	
					STD Terminal Block		OPT Circuit Breaker	
	Min Ckt. Ampacity (MCA) ⁴	Recommended Fuse/Ckt. Brkr Rating ⁵	Max. Inverse Time Ckt. Brkr. Rating ²	Max Dual Element Fuse Size ³	Lugs/Phase ¹	Lug Wire Range	Lugs/Phase ¹	Lug Wire Range
0157	624	700	1600	1000	4	2AWG - 600 kcmil	4	4/0AWG - 500 kcmil
	540	600	1600	1000	4	2AWG - 600 kcmil	4	4/0AWG - 500 kcmil
	341	400	800	600	3	2AWG - 600 kcmil	3	3/0AWG - 400 kcmil
	270	300	700	450	2	2AWG - 600 kcmil	2	2/0AWG - 500 kcmil
	216	250	500	350	2	2AWG - 600 kcmil	2	2/0AWG - 500 kcmil
0177	661	800	1600	1200	4	2AWG - 600 kcmil	4	4/0AWG - 500 kcmil
	572	700	1600	1000	4	2AWG - 600 kcmil	4	4/0AWG - 500 kcmil
	361	400	1000	600	3	2AWG - 600 kcmil	3	3/0AWG - 400 kcmil
	285	350	700	500	2	2AWG - 600 kcmil	2	2/0AWG - 500 kcmil
	229	250	600	400	2	2AWG - 600 kcmil	2	2/0AWG - 500 kcmil
0187	751	1000	1600	1200	4	2AWG - 600 kcmil	4	4/0AWG - 500 kcmil
	651	800	1600	1200	4	2AWG - 600 kcmil	4	4/0AWG - 500 kcmil
	411	500	1000	700	3	2AWG - 600 kcmil	3	3/0AWG - 400 kcmil
	324	400	800	500	2	2AWG - 600 kcmil	2	2/0AWG - 500 kcmil
	260	300	600	450	2	2AWG - 600 kcmil	2	2/0AWG - 500 kcmil
0197	799	1000	1600	1600	4	2AWG - 600 kcmil	4	4/0AWG - 500 kcmil
	692	800	1600	1200	4	2AWG - 600 kcmil	4	4/0AWG - 500 kcmil
	437	500	1000	700	3	2AWG - 600 kcmil	3	3/0AWG - 400 kcmil
	345	400	800	600	2	2AWG - 600 kcmil	2	2/0AWG - 500 kcmil
	277	350	700	450	2	2AWG - 600 kcmil	2	2/0AWG - 500 kcmil
0207	832	1000	1600	1600	4	2AWG - 600 kcmil	4	4/0AWG - 500 kcmil
	721	800	1600	1200	4	2AWG - 600 kcmil	4	4/0AWG - 500 kcmil
	455	500	1200	800	3	2AWG - 600 kcmil	3	3/0AWG - 400 kcmil
	359	400	1000	600	2	2AWG - 600 kcmil	2	2/0AWG - 500 kcmil
	288	350	700	500	2	2AWG - 600 kcmil	2	2/0AWG - 500 kcmil
0227	859	1000	1600	1600	4	2AWG - 600 kcmil	4	4/0AWG - 500 kcmil
	744	1000	1600	1200	4	2AWG - 600 kcmil	4	4/0AWG - 500 kcmil
	470	600	1200	800	3	2AWG - 600 kcmil	3	3/0AWG - 400 kcmil
	371	450	1000	600	2	2AWG - 600 kcmil	2	2/0AWG - 500 kcmil
	297	350	700	500	2	2AWG - 600 kcmil	2	2/0AWG - 500 kcmil
0247	982	1200	1600	1600	4	2AWG - 600 kcmil	4	4/0AWG - 500 kcmil
	851	1000	1600	1600	4	2AWG - 600 kcmil	4	4/0AWG - 500 kcmil
	537	600	1200	1000	3	2AWG - 600 kcmil	3	3/0AWG - 400 kcmil
	424	500	1000	700	2	2AWG - 600 kcmil	2	2/0AWG - 500 kcmil
	340	400	800	600	2	2AWG - 600 kcmil	2	2/0AWG - 500 kcmil

ELECTRICAL DATA (CONT'D)**STANDARD EFFICIENCY 2-Compressor Units**

(One Field Provided Power Supply Circuit.

Field Connections to Factory provided Terminal Block (Standard), or Individual System Breakers(Optional).

Model Number /Nameplate			System 1			System 2			Control KVA ⁸	Unit Short Circuit Withstand (KA)	
			Compressor	Cond. Fans		Compressor	Cond. Fans			Terminal Block (STD)	Circuit Breaker (OPT)
YCAV	Input Volts	Input Freq	RLA ⁶	Qty	FLA (EA)	RLA ⁶	Qty.	FLA (EA)			
0157	200	60	278	4	6.5	278	4	6.5	1.8	30KA	100KA
	230	60	241	4	5.6	241	4	5.6	1.8	30KA	100KA
	380	60	152	4	3.5	152	4	3.5	1.8	30KA	65KA
	460	60	120	4	2.8	120	4	2.8	1.8	30KA	65KA
	575	60	96	4	2.2	96	4	2.2	1.8	30KA	42KA
0177	200	60	368	4	6.5	244	4	6.5	1.8	30KA	100KA
	230	60	319	4	5.6	211	4	5.6	1.8	30KA	100KA
	380	60	201	4	3.5	133	4	3.5	1.8	30KA	65KA
	460	60	159	4	2.8	105	4	2.8	1.8	30KA	65KA
	575	60	127	4	2.2	84	4	2.2	1.8	30KA	42KA
0187	200	60	376	5	6.5	278	4	6.5	1.8	30KA	100KA
	230	60	325	5	5.6	241	4	5.6	1.8	30KA	100KA
	380	60	205	5	3.5	152	4	3.5	1.8	30KA	65KA
	460	60	162	5	2.8	120	4	2.8	1.8	30KA	65KA
	575	60	130	5	2.2	96	4	2.2	1.8	30KA	42KA
0207	200	60	336	5	6.5	379	4	6.5	1.8	30KA	100KA
	230	60	291	5	5.6	328	4	5.6	1.8	30KA	100KA
	380	60	184	5	3.5	207	4	3.5	1.8	30KA	65KA
	460	60	145	5	2.8	163	4	2.8	1.8	30KA	65KA
	575	60	116	5	2.2	131	4	2.2	1.8	30KA	42KA
0227	200	60	375	5	6.5	375	5	6.5	1.8	30KA	100KA
	230	60	325	5	5.6	325	5	5.6	1.8	30KA	100KA
	380	60	205	5	3.5	205	5	3.5	1.8	30KA	65KA
	460	60	162	5	2.8	162	5	2.8	1.8	30KA	65KA
	575	60	130	5	2.2	130	5	2.2	1.8	30KA	42KA
0247	200	60	448	6	6.5	371	5	6.5	1.8	30KA	100KA
	230	60	388	6	5.6	321	5	5.6	1.8	30KA	100KA
	380	60	245	6	3.5	203	5	3.5	1.8	30KA	65KA
	460	60	193	6	2.8	160	5	2.8	1.8	30KA	65KA
	575	60	155	6	2.2	128	5	2.2	1.8	30KA	42KA
0267	200	60	444	6	6.5	444	6	6.5	1.8	30KA	100KA
	230	60	385	6	5.6	385	6	5.6	1.8	30KA	100KA
	380	60	242	6	3.5	242	6	3.5	1.8	30KA	65KA
	460	60	191	6	2.8	191	6	2.8	1.8	30KA	65KA
	575	60	154	6	2.2	154	6	2.2	1.8	30KA	42KA

ELECTRICAL DATA (CONT'D)**STANDARD EFFICIENCY 2-Compressor Units (Con't)**

(One Field Provided Power Supply Circuit.
Field Connections to Factory provided Terminal Block (Standard),
or Individual System Breakers(Optional).

YCAV	Field Wiring & Protection				Field Wiring Lugs STD Terminal Block		Field Wiring Lugs OPT Circuit Breaker	
	Minimum Ckt. Ampacity (MCA) ⁴	Recommended Fuse/Ckt. Breaker Rating ⁵	Max. Inverse Time Ckt. Brkr. Rating ²	Max Dual Element Fuse Size ³	Lugs/ Phase ¹	Lug Wire Range	Lugs/ Phase ¹	Lug Wire Range
0157	677	800	1600	1200	4	2AWG - 600 kcmil	4	4/0AWG - 500 kcmil
	587	700	1600	1000	4	2AWG - 600 kcmil	4	4/0AWG - 500 kcmil
	370	450	1000	600	3	2AWG - 600 kcmil	3	3/0AWG - 400 kcmil
	293	350	700	500	2	2AWG - 600 kcmil	2	2/0AWG - 500 kcmil
	234	300	600	400	2	2AWG - 600 kcmil	2	2/0AWG - 500 kcmil
0177	755	1000	2000	1200	4	2AWG - 600 kcmil	4	4/0AWG - 500 kcmil
	654	800	1600	1200	4	2AWG - 600 kcmil	4	4/0AWG - 500 kcmil
	413	500	1000	700	3	2AWG - 600 kcmil	3	3/0AWG - 400 kcmil
	326	400	800	600	2	2AWG - 600 kcmil	2	2/0AWG - 500 kcmil
	261	300	600	450	2	2AWG - 600 kcmil	2	2/0AWG - 500 kcmil
0187	805	1000	2000	1600	4	2AWG - 600 kcmil	4	4/0AWG - 500 kcmil
	698	800	1600	1200	4	2AWG - 600 kcmil	4	4/0AWG - 500 kcmil
	440	500	1000	700	3	2AWG - 600 kcmil	3	3/0AWG - 400 kcmil
	348	400	800	600	2	2AWG - 600 kcmil	2	2/0AWG - 500 kcmil
	279	350	700	450	2	2AWG - 600 kcmil	2	2/0AWG - 500 kcmil
0207	857	1000	2000	1600	4	2AWG - 600 kcmil	4	4/0AWG - 500 kcmil
	742	1000	2000	1200	4	2AWG - 600 kcmil	4	4/0AWG - 500 kcmil
	468	600	1200	800	3	2AWG - 600 kcmil	3	3/0AWG - 400 kcmil
	370	450	1000	600	2	2AWG - 600 kcmil	2	2/0AWG - 500 kcmil
	296	350	700	500	2	2AWG - 600 kcmil	2	2/0AWG - 500 kcmil
0227	908	1200	2000	1600	4	2AWG - 600 kcmil	4	4/0AWG - 500 kcmil
	786	1000	2000	1600	4	2AWG - 600 kcmil	4	4/0AWG - 500 kcmil
	496	600	1200	800	3	2AWG - 600 kcmil	3	3/0AWG - 400 kcmil
	392	450	1000	700	2	2AWG - 600 kcmil	2	2/0AWG - 500 kcmil
	314	350	800	500	2	2AWG - 600 kcmil	2	2/0AWG - 500 kcmil
0247	1002	1200	2000	1600	4	2AWG - 600 kcmil	4	4/0AWG - 500 kcmil
	868	1000	2000	1600	4	2AWG - 600 kcmil	4	4/0AWG - 500 kcmil
	547	700	1600	1000	3	2AWG - 600 kcmil	3	3/0AWG - 400 kcmil
	432	500	1000	700	2	2AWG - 600 kcmil	2	2/0AWG - 500 kcmil
	347	400	800	600	2	2AWG - 600 kcmil	2	2/0AWG - 500 kcmil
0267	1076	1200	2000	2000	4	2AWG - 600 kcmil	4	4/0AWG - 500 kcmil
	932	1200	2000	1600	4	2AWG - 600 kcmil	4	4/0AWG - 500 kcmil
	588	700	1600	1000	3	2AWG - 600 kcmil	3	3/0AWG - 400 kcmil
	464	600	1200	800	2	2AWG - 600 kcmil	2	2/0AWG - 500 kcmil
	372	450	1000	600	2	2AWG - 600 kcmil	2	2/0AWG - 500 kcmil

ELECTRICAL WIRING

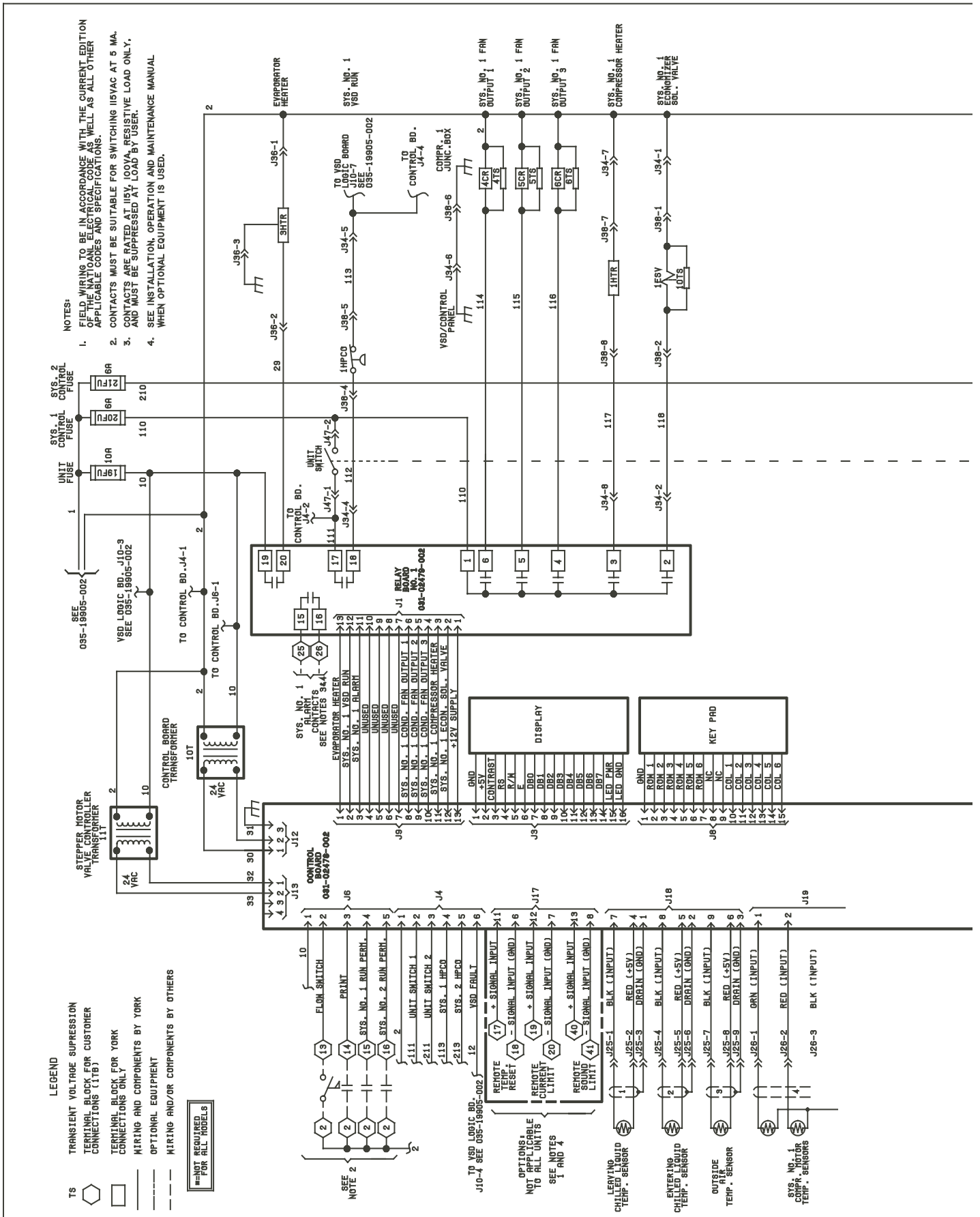

FIG. 3 - ELEMENTARY CONTROL WIRING DIAGRAM

LD10511

ELECTRICAL WIRING (CONT'D)

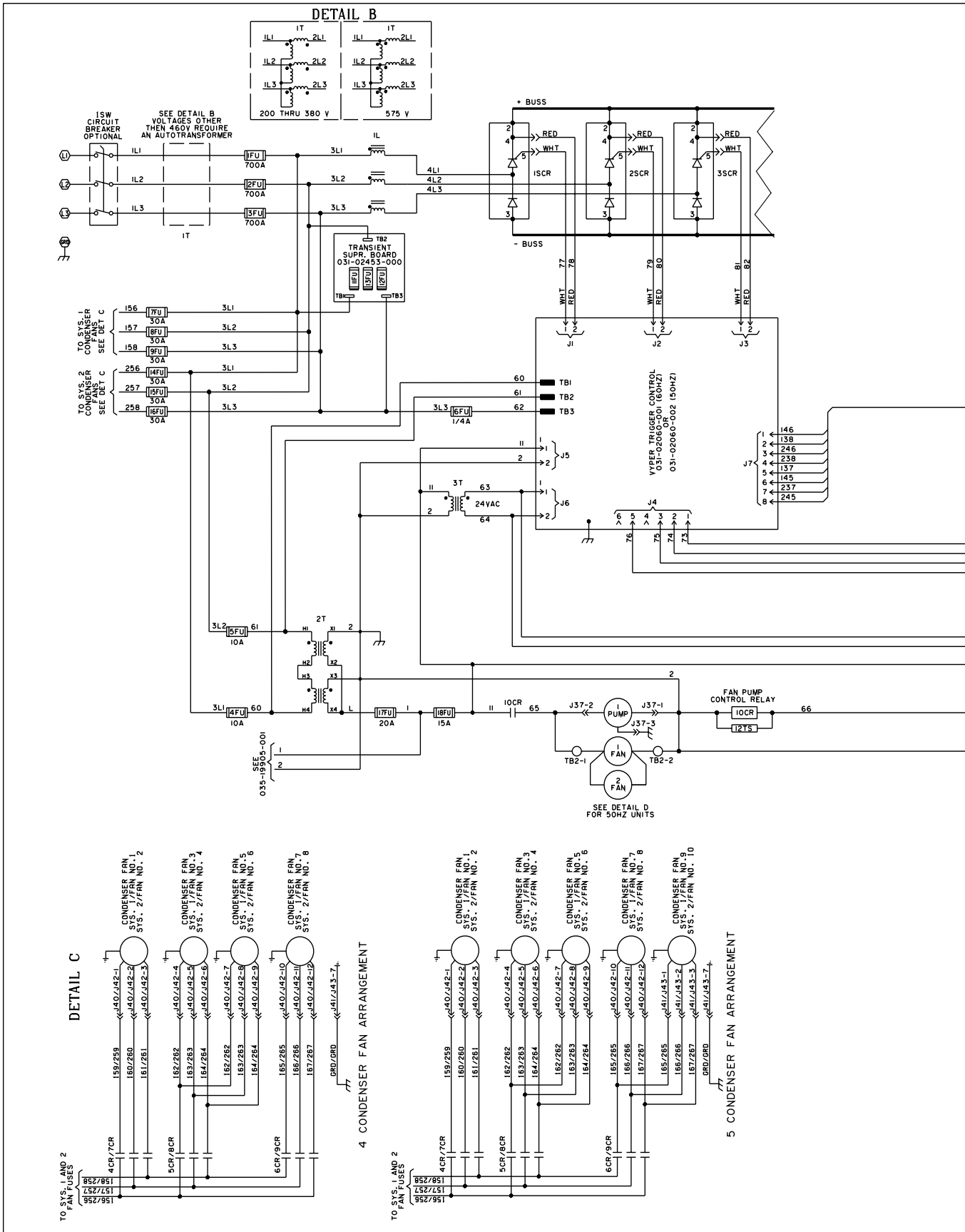
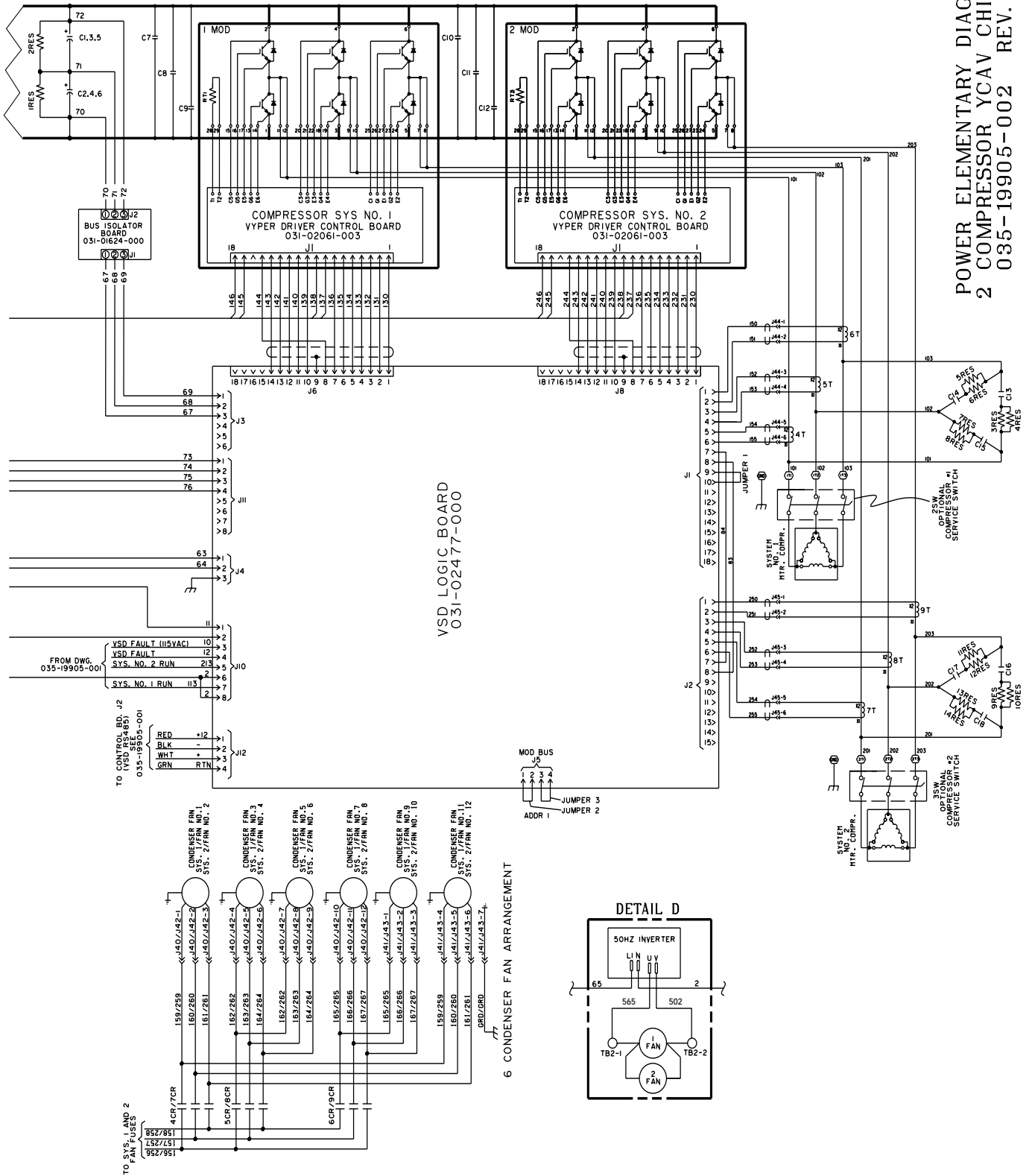

FIG. 4 - ELEMENTARY POWER WIRING DIAGRAM - 2 COMPRESSOR YCAV CHILLER

ELECTRICAL WIRING (CONT'D)

POWER ELEMENTARY DIAGRAM
2 COMPRESSOR YCAV CHILLER
035-19905-002 REV. A



ELEMENTARY POWER WIRING DIAGRAM - 2 COMPRESSOR YCAV CHILLER (CON'T)

ELECTRICAL WIRING (CONT'D)

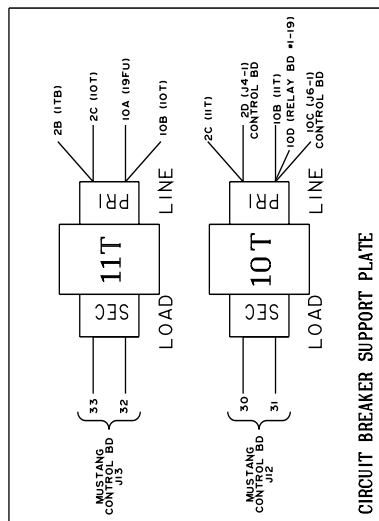

SYSTEM 2

SYSTEM 1

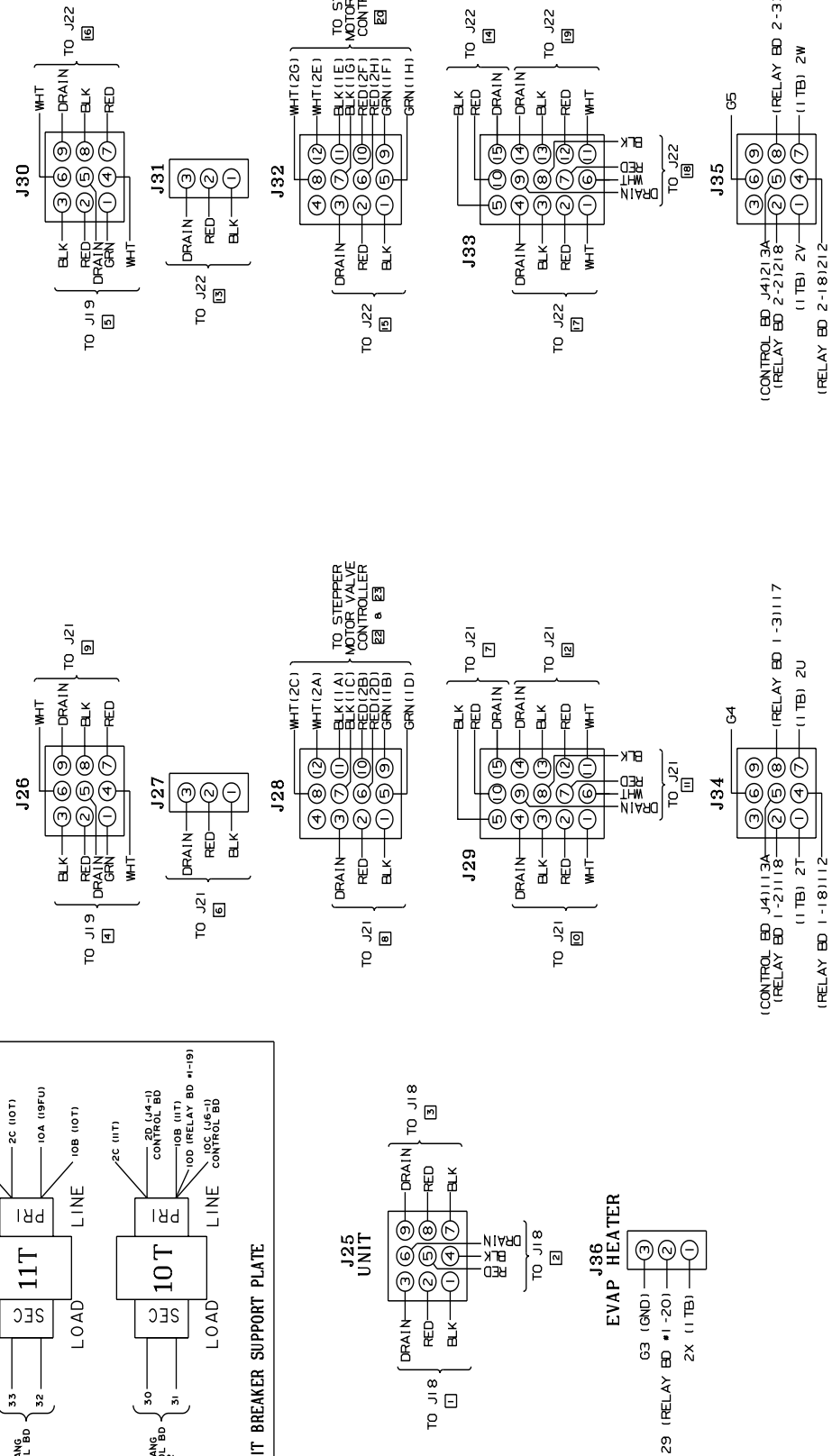

CONTROL WIRING - CONNECTION DIAGRAM
 2 COMPRESSOR YCAV CHILLER
 035-19905-003 REV A

ELECTRICAL WIRING (CONT'D)

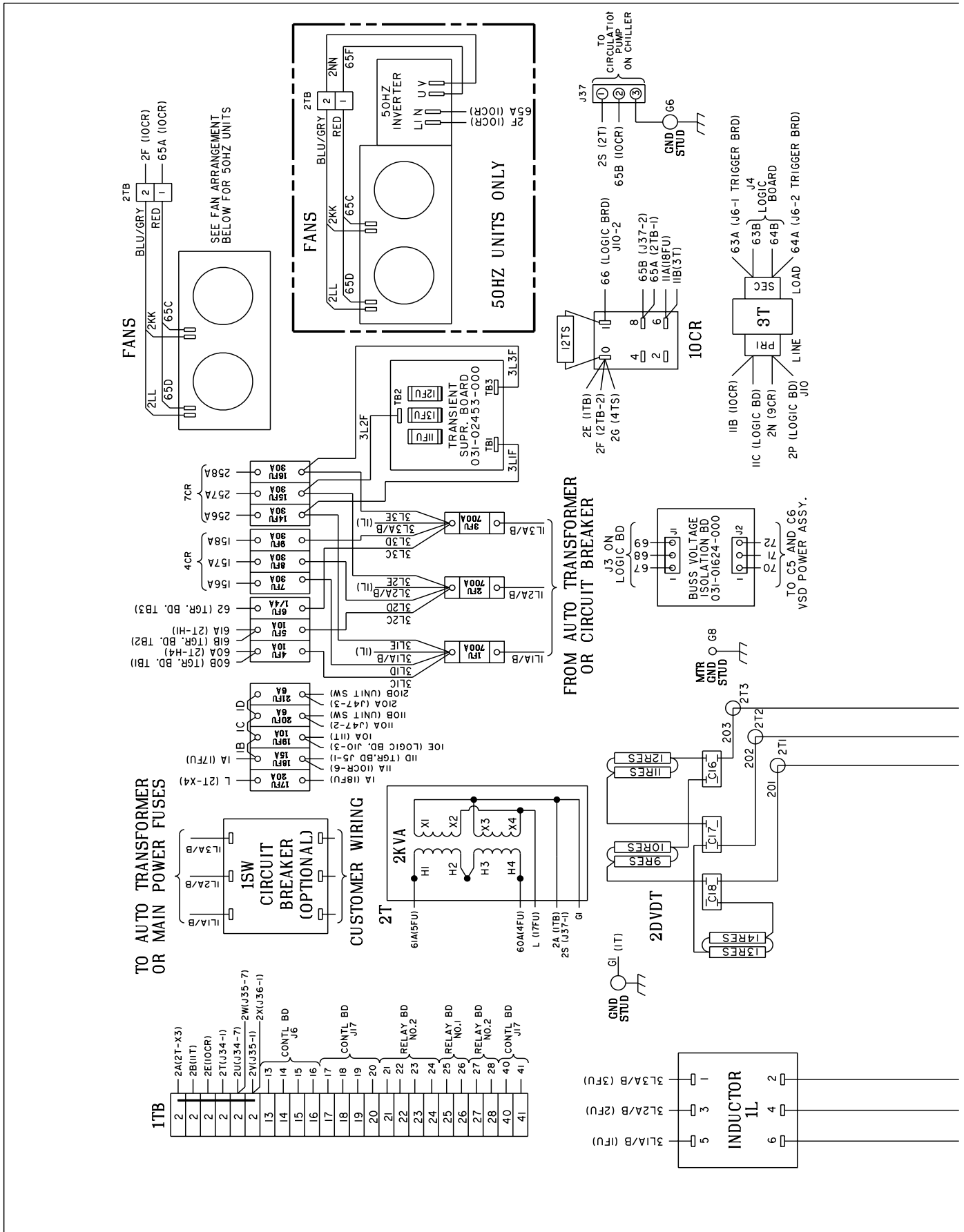
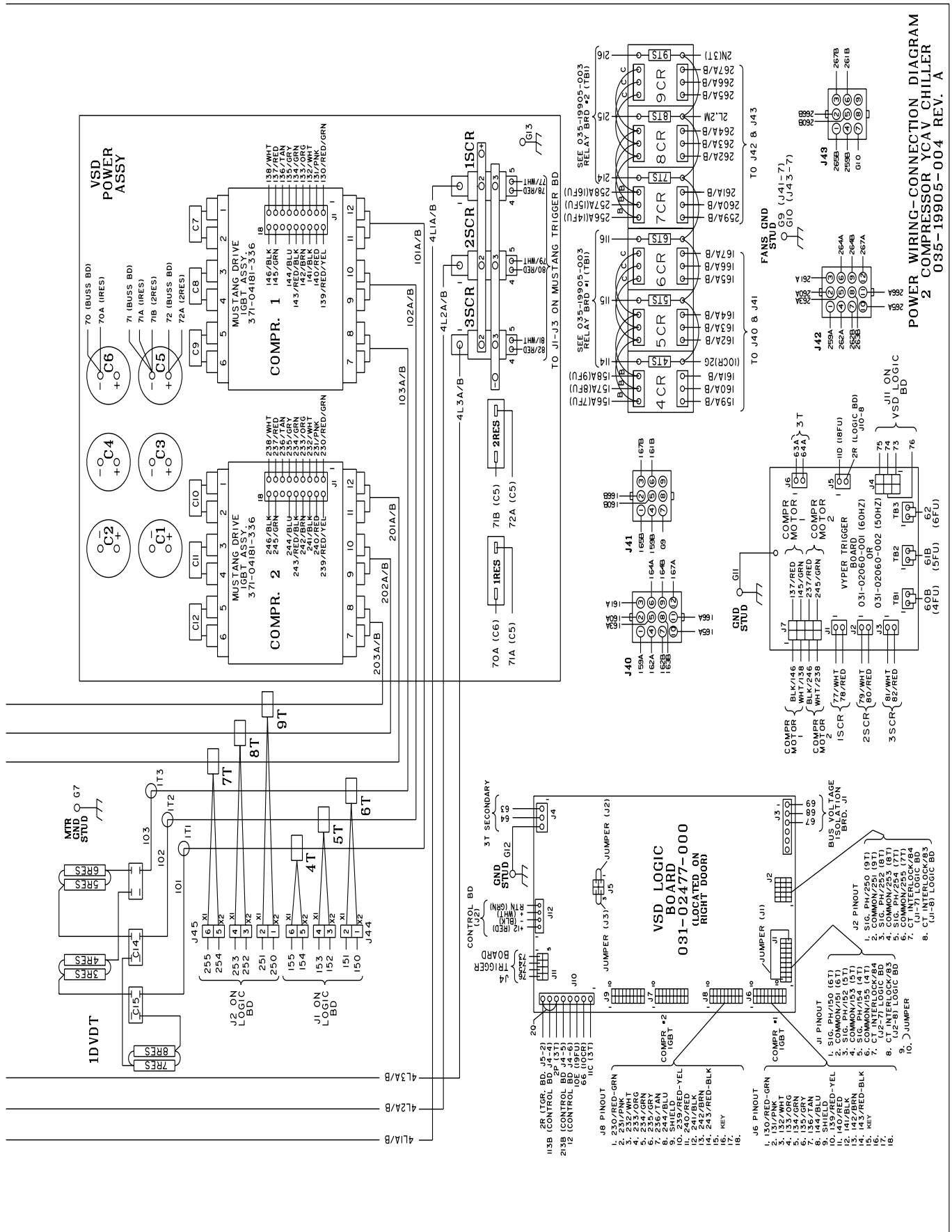

FIG 6 – CONNECTION WIRING DIAGRAM - 2 COMPRESSOR YCAV CHILLER

LD10517

ELECTRICAL WIRING (CONT'D)



CONNECTION WIRING DIAGRAM - 2 COMPRESSOR YCAV CHILLER (CONT')

HARNES LOCATIONS

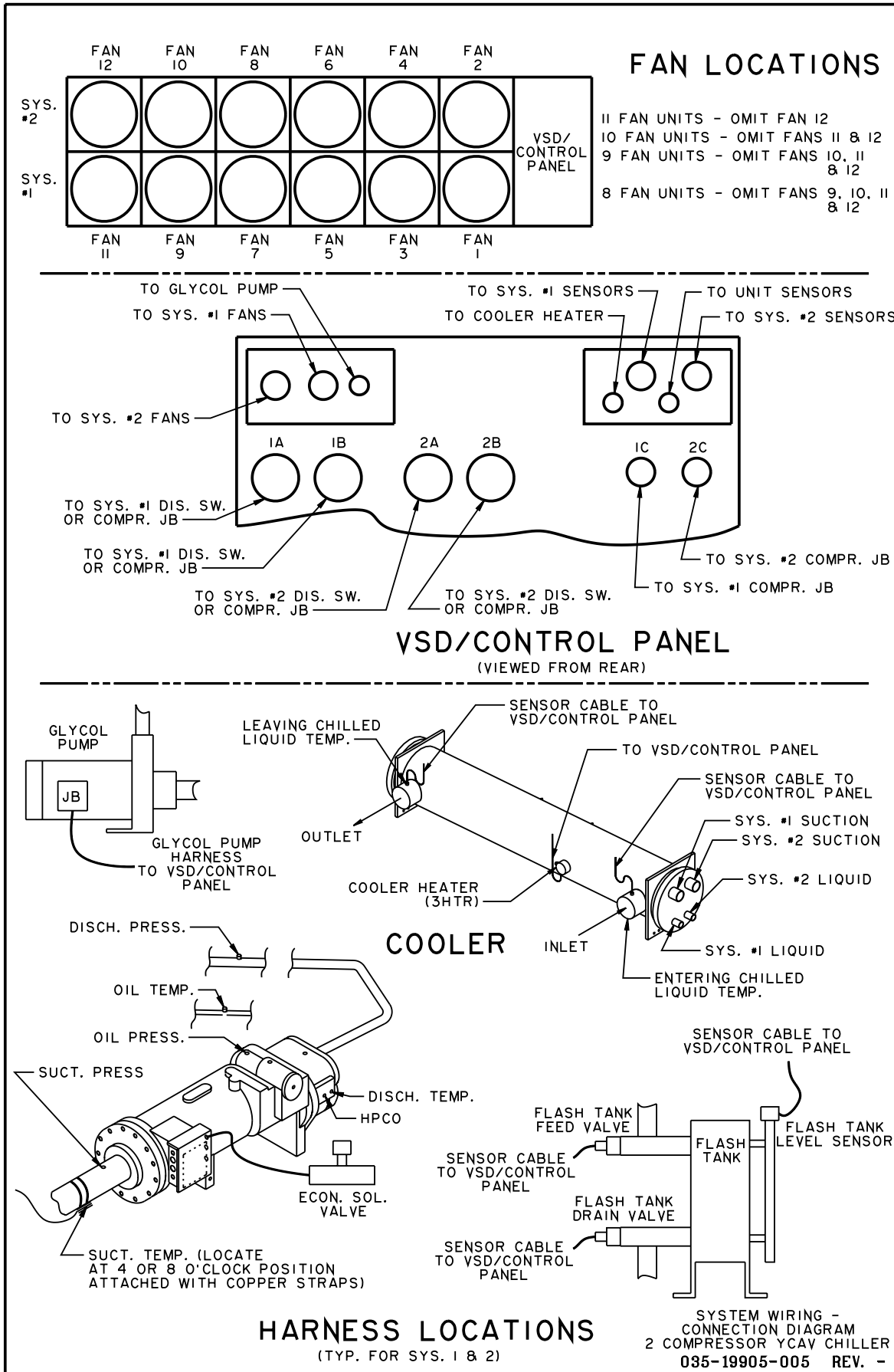

FIG. 7 - HARNES LOCATIONS

LD10519

POWER AND ELECTRICAL REQUIREMENTS

A. Power/Control Panel:

1. NEMA 3R (IP65), powder painted steel cabinets with hinged, latched, and gasket sealed outer doors equipped with wind struts for safer servicing. Provide main power connection(s), compressor starters and fan motor contactors, current overloads, and factory wiring.
2. Panel shall include control display access door.

B. Single Point Power:

1. Provide single point power connection to chiller, shall be 3 phase of scheduled voltage.
2. Circuit breaker shall be provided at point of incoming single point connection to provide disconnecting means AND be sized to provide the motor branch circuit protection, short circuit protection and ground fault protection for the motor branch-circuit conductors, the motor control apparatus and the motors. Circuit breaker shall be equipped with lockable operating handle that shall extend through power panel door so that power may be disconnected without opening any panel doors.

C. Control Transformer:

1. Power panel shall be supplied with a factory mounted and wired control transformer that will supply all unit control voltage from the main unit power supply. Transformer shall utilize scheduled line voltage on the primary side and provide 115V/1Ø on secondary.

D. Short Circuit Withstand Rating of the chiller:

1. Short Circuit Withstand Rating of the chiller electrical enclosure shall be (200V & 230V: 100,000 Amps, 380 & 460V: 65,000 Amps, 575V: 42,000 Amps). Rating shall be in accordance with UL508.

E. Power Factor:

1. Provide equipment with power factor correction capacitors as required to maintain a power factor of 95% at all load conditions.
2. The installing contractor is responsible for additional cost to furnish and install power factor correction capacitors if they are not factory mounted and wired.

F. Exposed power wiring:

1. Exposed compressor and fan motor power wiring shall be routed through liquid tight conduit.



P.O. Box 1592, York, Pennsylvania USA 17405-1592
Copyright © by YORK International Corporation 2005
Form 201.21-W1 (405)
New Release

Tele. 800-861-1001
www.york.com

Subject to change without notice. Printed in USA
ALL RIGHTS RESERVED