

# **YORK**<sup>®</sup> Centrifugal Chillers

Model YMC<sup>2</sup> – YORK Magnetic Centrifugal Chillers (800-1970 kW / 215-560 Tons)



Nantes November 2014

Johnson  
Controls 



## Session Objectives



- Effectively communicate the value and benefits of YMC<sup>2</sup> chillers
- More effectively use chiller selection tools
- Identify where to find more information that will help you sell

# YMC<sup>2</sup> – YORK Magnetic Centrifugal Chillers (800-1970 kW / 215-560 Tons)



## Agenda

---

- YMC<sup>2</sup> Customer Presentation
- Vertical Market Applications
- Positioning Strategy
- What's Different, What's the Same
- YMC<sup>2</sup> Overview - Layout
- YMC<sup>2</sup> vs. YK
- YMC<sup>2</sup> Deep Dive
- Competition
- Marketing Collateral / Self Guided Study
- YCS<sup>2</sup> Ratings Program Review



# YORK<sup>®</sup> Centrifugal Chillers

Model YMC<sup>2</sup> – YORK Magnetic Centrifugal Chillers (800-1340 kW)



# YMC<sup>2</sup>

## Customer Presentation

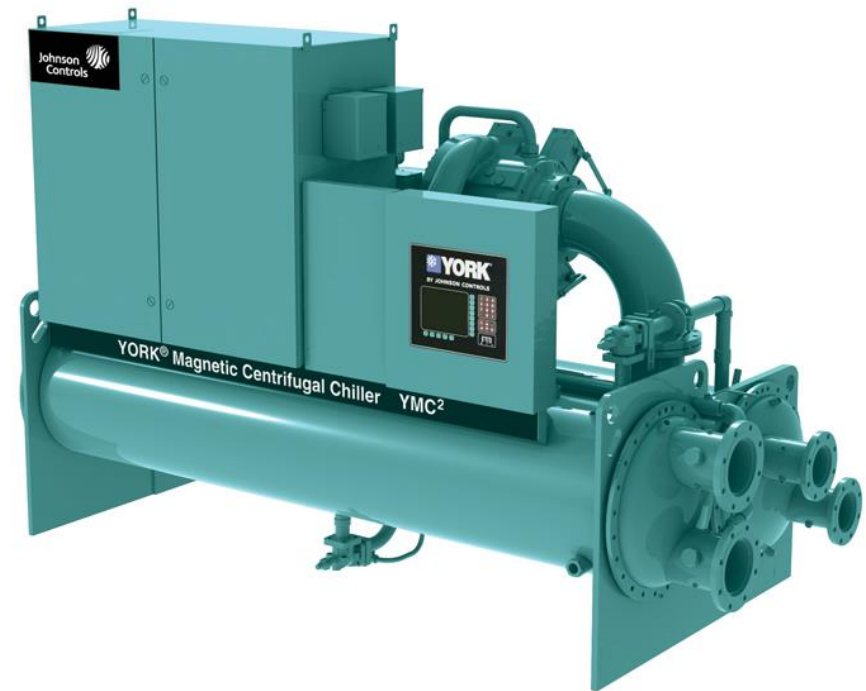

Product Overview Presentation

# YORK YMC<sup>2</sup> Centrifugal Chillers



Client's Company Name

Account Executive Name, June 8, 2010



# YMC<sup>2</sup> – YORK Magnetic Centrifugal Chillers

## YORK - A History of Leadership and Innovation

The global market leader in centrifugal chillers with a history of Innovation:

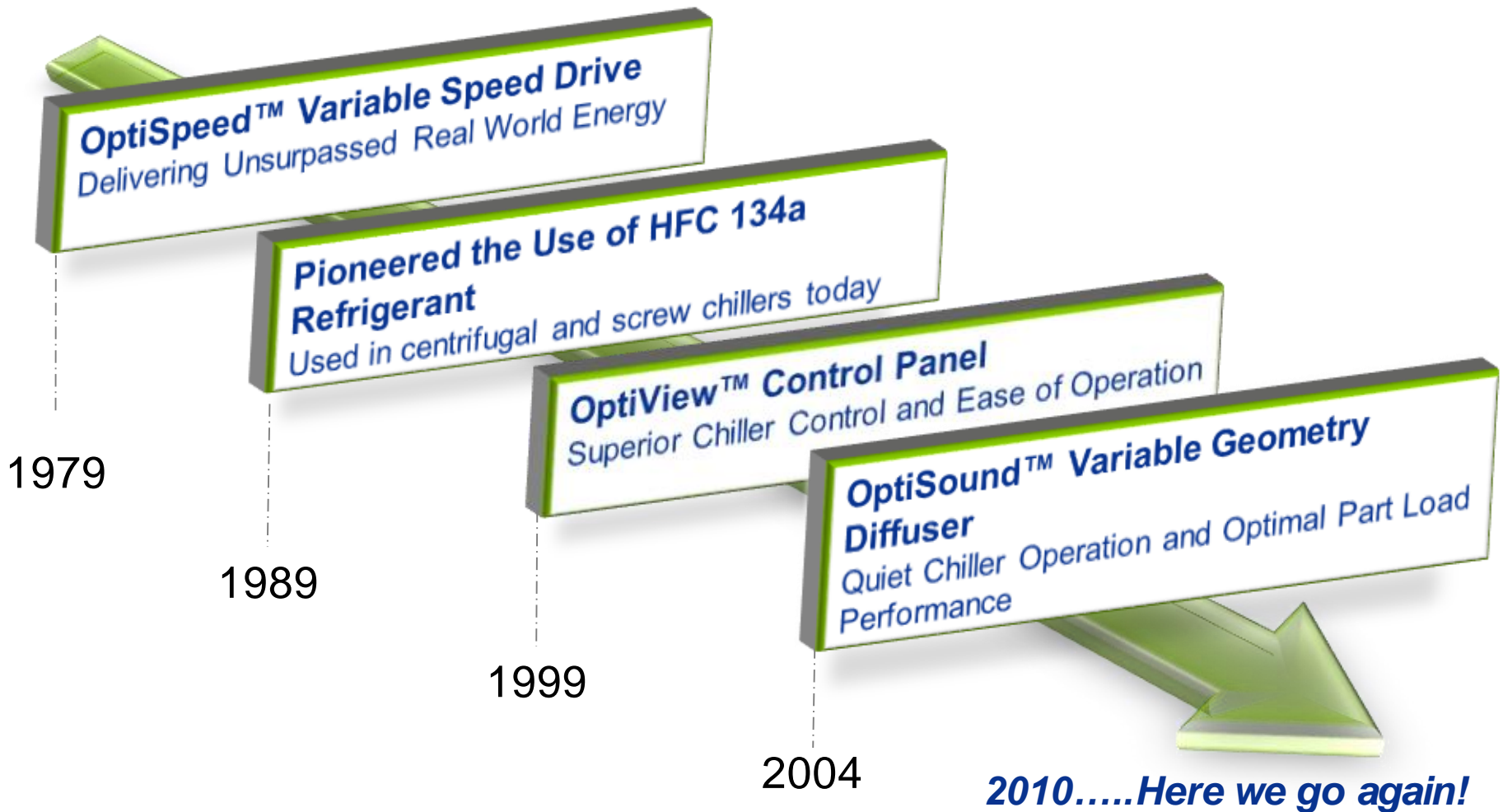

# YMC<sup>2</sup> – YORK Magnetic Centrifugal Chillers

## Four key benefits

---

- 1. Efficiency** – Reduce your consumption
- 2. Sustainability** – Improve your environmental equation
- 3. Low Sound** – Save your voice
- 4. Max uptime** – Increase your hours



# YMC<sup>2</sup> – YORK Magnetic Centrifugal Chillers

## Overview

---

### Giant leap for chiller technology

- Possible by intelligent application of best-in-class technologies
- The result is greater than the sum of its parts
- Not just another small incremental step – a breakthrough



# YMC<sup>2</sup> – YORK Magnetic Centrifugal Chillers

## Overview

---

### Key technology elements of the system

- **Compressor aerodynamics** – proven YORK YK design
- **Heat exchangers** – high efficiency falling film evaporator
- **Controls** – leveraging YORK and Johnson Controls technology
- **Variable speed drive** – from the pioneer in VSD centrifugals
- **Magnetic bearings** – industrial technology, now ready for the mainstream



# YMC<sup>2</sup> – YORK Magnetic Centrifugal Chillers

## Employ Superior Efficiency

---



## Employ Superior Efficiency



# YMC<sup>2</sup> – YORK Magnetic Centrifugal Chillers

## Employ Superior Efficiency



- Real world efficiency
- Lowest operational costs

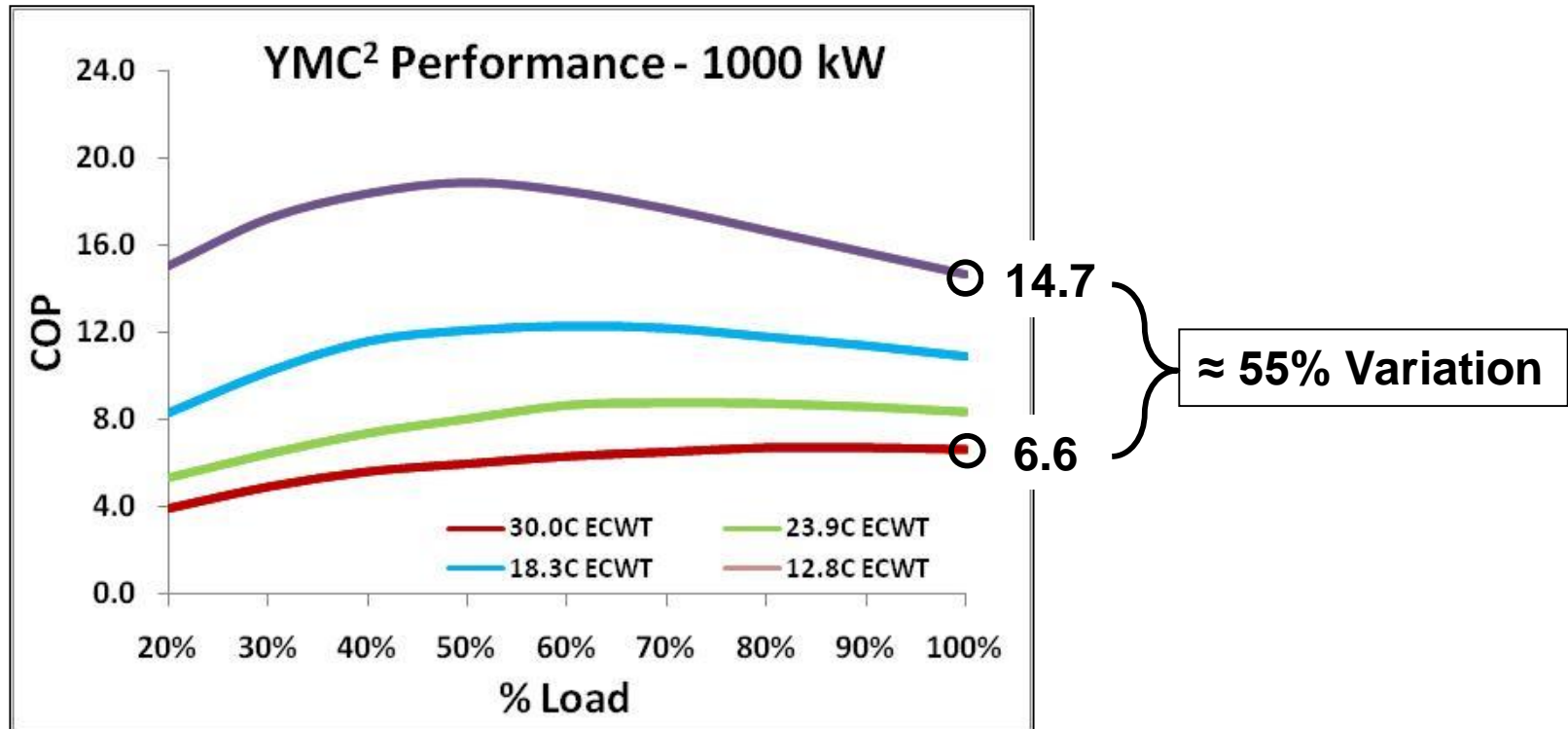

# YMC<sup>2</sup> – YORK Magnetic Centrifugal Chillers

## Employ Superior Efficiency

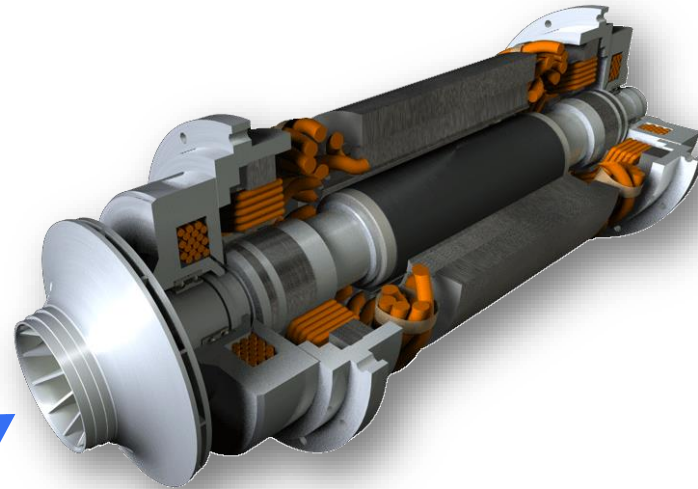

Proven aerodynamic designs from our flagship YK product line

# YMC<sup>2</sup> – YORK Magnetic Centrifugal Chillers

## Employ Superior Efficiency

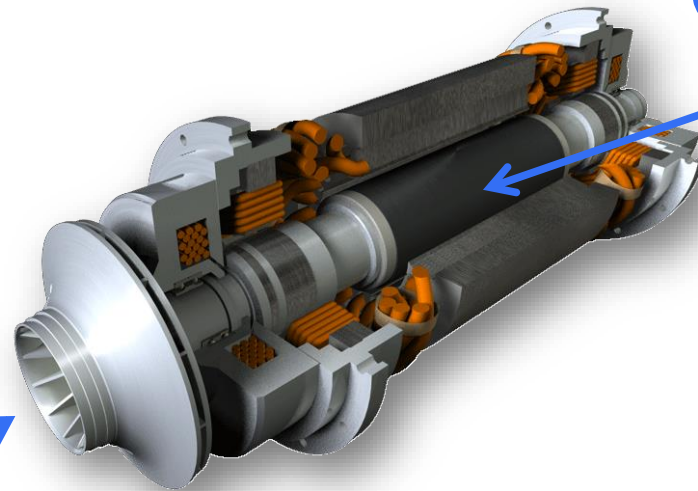

Permanent magnet motor with active magnetic bearings

Proven aerodynamic designs from our flagship YK product line

# YMC<sup>2</sup> – YORK Magnetic Centrifugal Chillers

## Employ Superior Efficiency



OptiSpeed™ Variable Speed Drive

Permanent magnet motor with active magnetic bearings



Proven aerodynamic designs from our flagship YK product line

# YMC<sup>2</sup> – YORK Magnetic Centrifugal Chillers

## Employ Superior Efficiency



OptiSpeed™ Variable Speed Drive

Permanent magnet motor with active magnetic bearings



Proven aerodynamic designs from our flagship YK product line

OptiView™ Control Center

# YMC<sup>2</sup> – YORK Magnetic Centrifugal Chillers

## Specify Superior Sustainability



## Specify Superior Sustainability

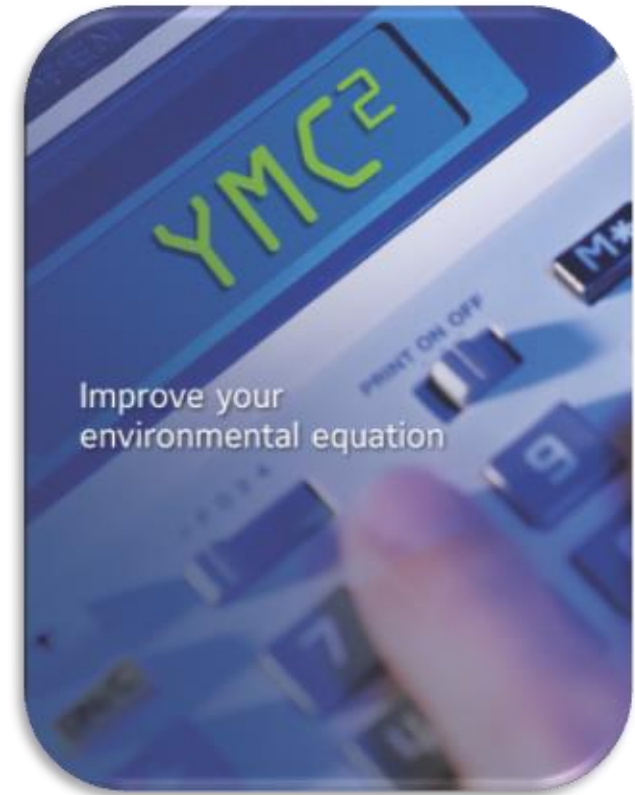

# YMC<sup>2</sup> – YORK Magnetic Centrifugal Chillers

## Specify Superior Sustainability



- Leak-free design using HFC-134a refrigerant.
- ZERO ozone depletion potential (ODP)
- Falling film evaporator technology
- Very low refrigerant charge: up to 30% less than traditional designs

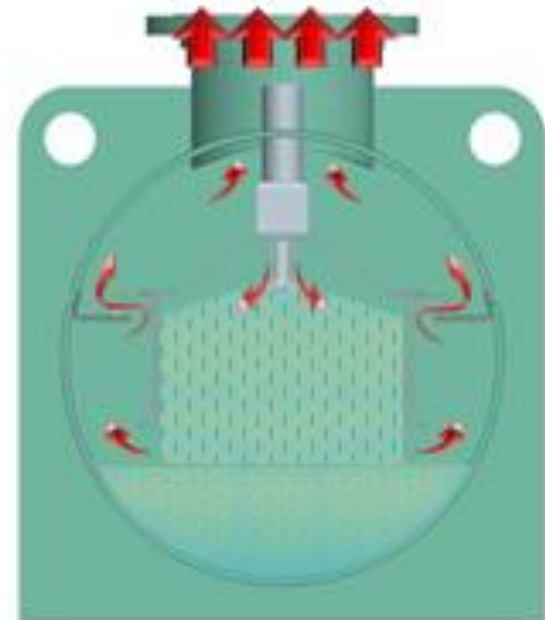

# YMC<sup>2</sup> – YORK Magnetic Centrifugal Chillers

## Specify Superior Sustainability



- Falling film evaporator technology
- Leak-free design using HFC-134a refrigerant
- ZERO ozone depletion potential (ODP)
- Very low refrigerant charge: up to 30% less than traditional designs

**Lower direct and indirect environmental impact**

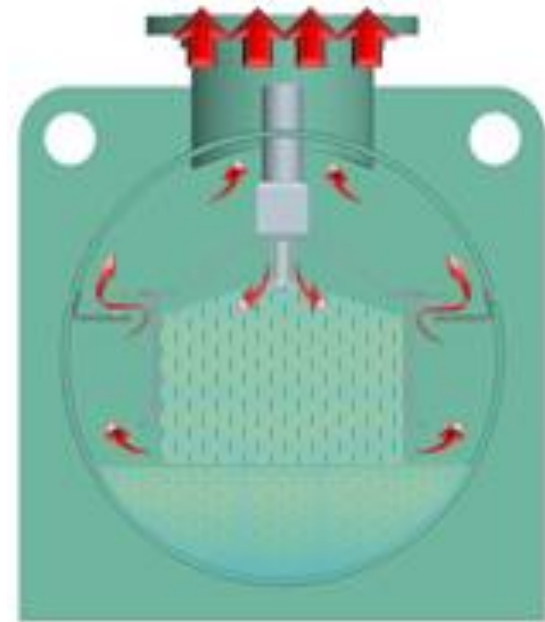

# YMC<sup>2</sup> – YORK Magnetic Centrifugal Chillers

## Acquire Superior Attenuation

---

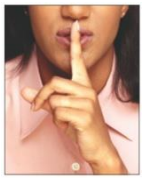

## Acquire Superior Attenuation

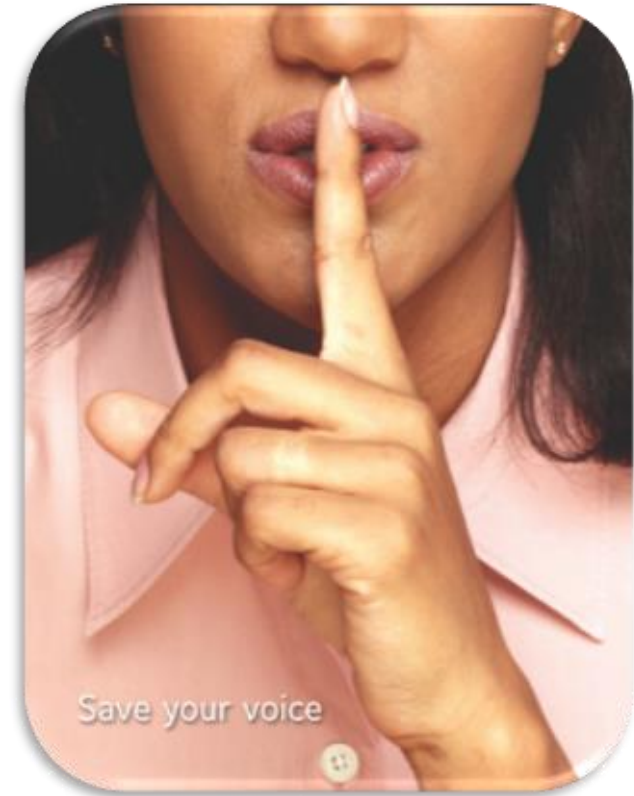

# YMC<sup>2</sup> – YORK Magnetic Centrifugal Chillers

## Acquire Superior Attenuation

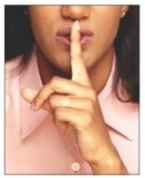

**Lowest sound levels on the market  
(73 dBA or less\*)**

**Achieved through the use of:**

- Permanent magnet motor with active magnetic bearings
- OptiSound™ Control

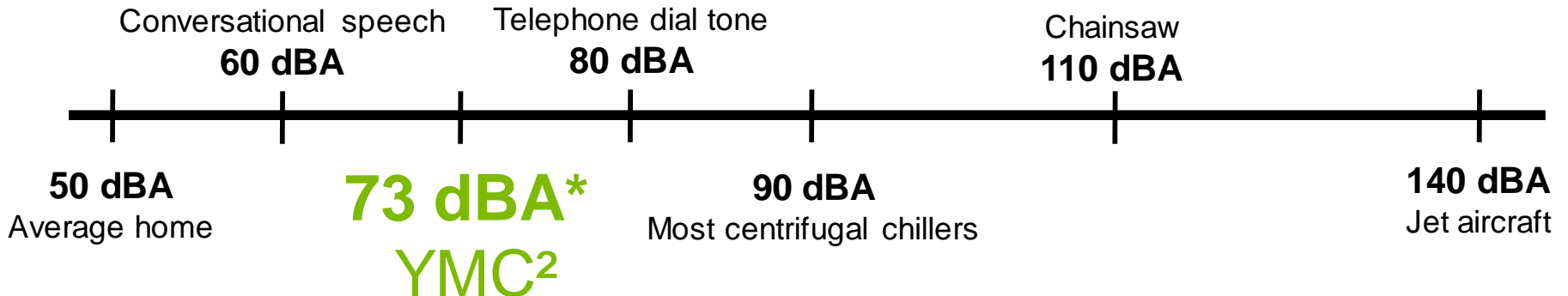

\* Sound pressure level in dB(A) at 1m

# YMC<sup>2</sup> – YORK Magnetic Centrifugal Chillers

## Demand Superior Dependability



**Demand Superior Dependability**



# YMC<sup>2</sup> – YORK Magnetic Centrifugal Chillers

## Demand Superior Dependability



### ■ Proven Technology

- Time Tested YK Components
- YORK Products delivered with Magnetic Bearing technology for more than 10 years (industrial and military)
- **Oil Free Design** – cutting down on required chiller maintenance.
- **Fast starts, fast restarts**
- **OptiSound™ Control** – ensures safe operation over a wide range of load and lift conditions
- **OptiSpeed™ VSD** – for improved motor life
- **OptiView™ Control** – with trending capabilities
- **Field Serviceability**

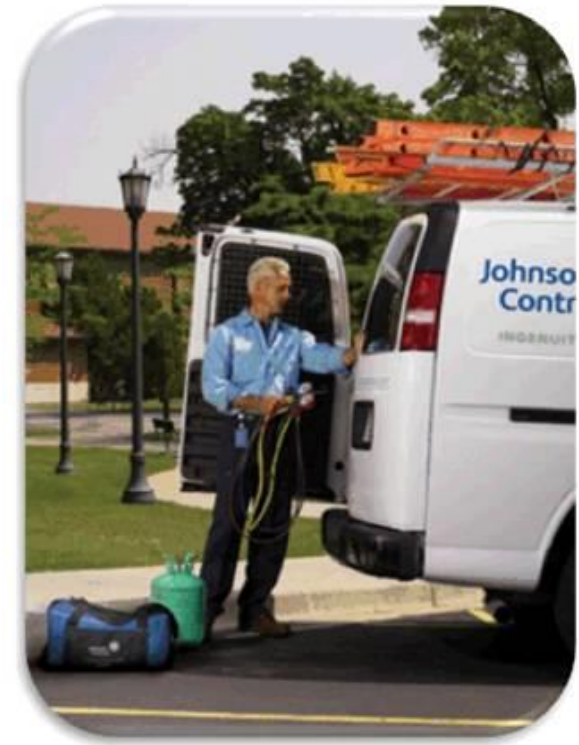

**Beyond reliability.  
Maximized Uptime**

# YMC<sup>2</sup> – YORK Magnetic Centrifugal Chillers

## The total package – meeting customer and environmental needs

---

- 1. Efficiency** – Reduce your consumption
- 2. Sustainability** – Improve your environmental equation
- 3. Low Sound** – Save your voice
- 4. Max uptime** – Increase your hours



Product Overview Presentation

# YORK YMC<sup>2</sup> Centrifugal Chillers



Client's Company Name

Account Executive Name, June 8, 2010



# YMC<sup>2</sup>

## Product Positioning

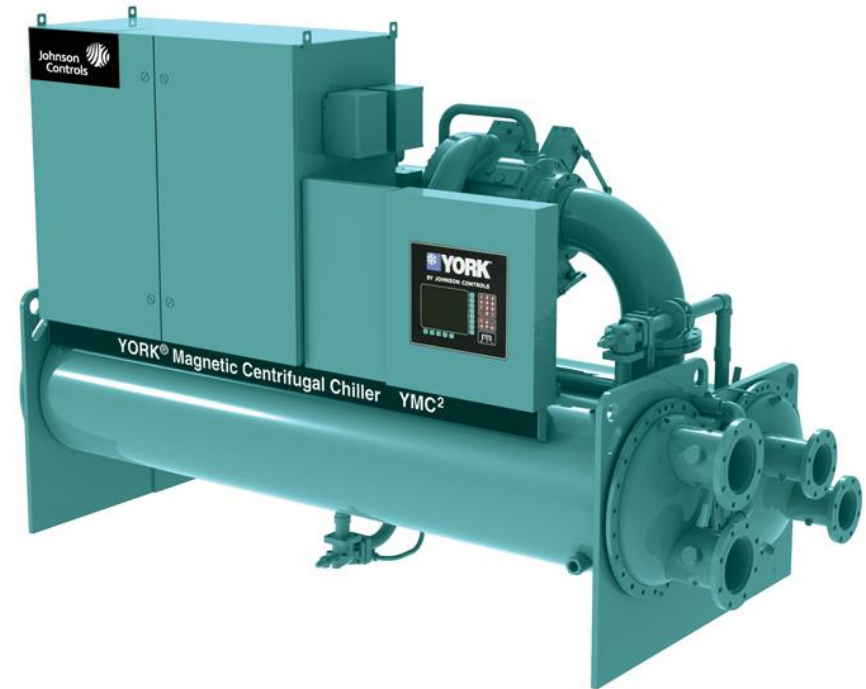

# YMC<sup>2</sup> – YORK Magnetic Centrifugal Chillers (800-1950 kW)

## Positioning Strategy

Eurovent market  
report in units

YMC<sup>2</sup> offering is 800-  
1950 kW

**Sweet Spot:  
From**

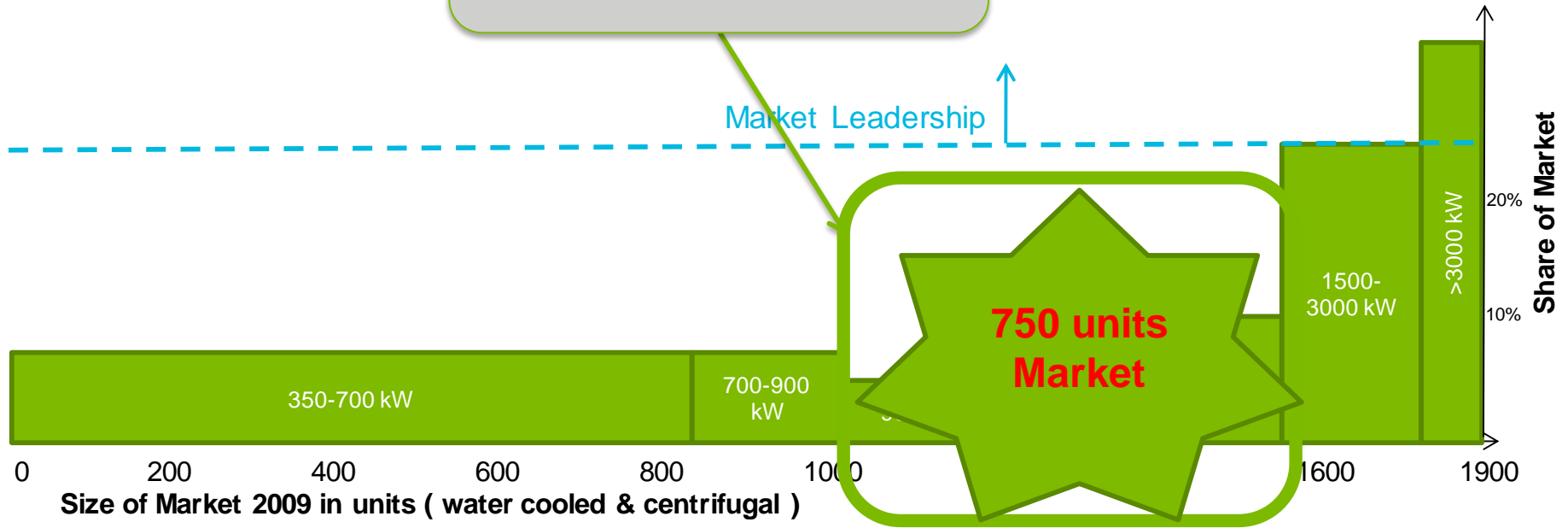

Source: Eurovent 2009

**Scroll**

**Screw**

**Centrifugal**

**YMC<sup>2</sup>**

# YMC<sup>2</sup> – YORK Magnetic Centrifugal Chillers (800-1950 kW) Positioning Strategy

How to specify and offer the YMC<sup>2</sup>

**Most Price Effective Capacity Range ( Sweet Spot)**

**900 kW to 1200 kW**

**Good Efficiency**

**Full Load < 6.1 COP @**

IPLV < 8.0 COP

**Better Efficiency**

**Full Load up to 6.5 COP @**

IPLV < 9.0 COP

**Best Part Load Effic.  
as Possible**

Full Load up to 6.5 COP @

**IPLV > 9.1 COP**

**Competitor**



**Carrier 30HX (Screw)  
Trane ERTHD ( Screw)**

**Competitor**



**Carrier 19XRV-  
23XRV\_30XWV  
(Cent.& Screw - VSD)**

**Competitor**



**Axima Quantum,  
Climaveneta TCS-HF,  
McQuay WMC.  
(All Turbocor)**

# YMC<sup>2</sup> – YORK Magnetic Centrifugal Chillers (800-1950 kW) Positioning Strategy

## Performance Analysis – Best Efficiency Segment 1230 kW Chiller

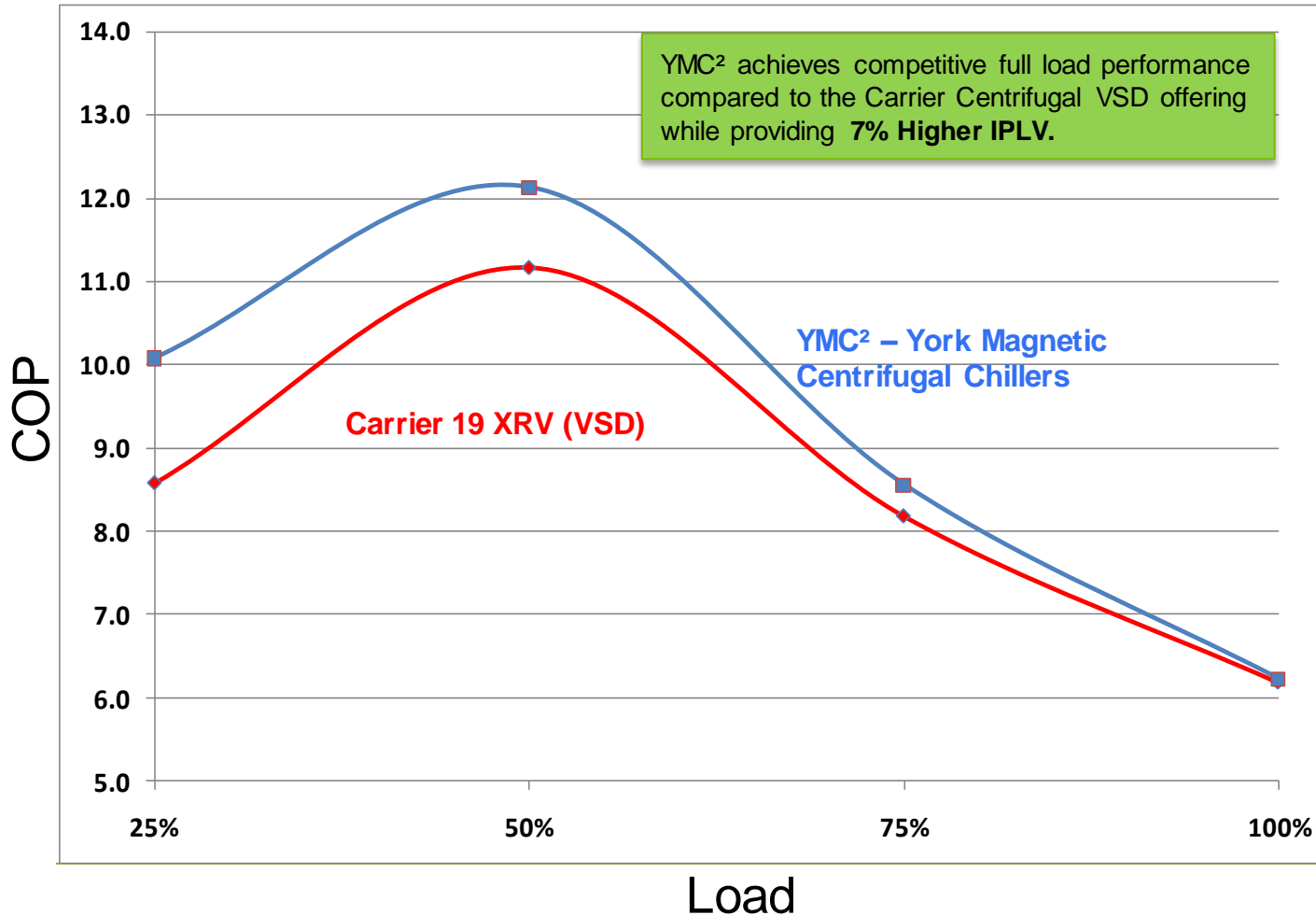

**NOT Eurovent Certified**  
AHRI Certified



**Carrier 19XRV  
(VSD)**



**YMC<sup>2</sup> – York Magnetic  
Centrifugal Chillers**

**Eurovent Certified**  
AHRI Certified

# YMC<sup>2</sup> – YORK Magnetic Centrifugal Chillers (800-1950 kW)

## Positioning Strategy

### Performance Analysis - Best Part Load Effic. Segment

#### 1230 kW Chiller

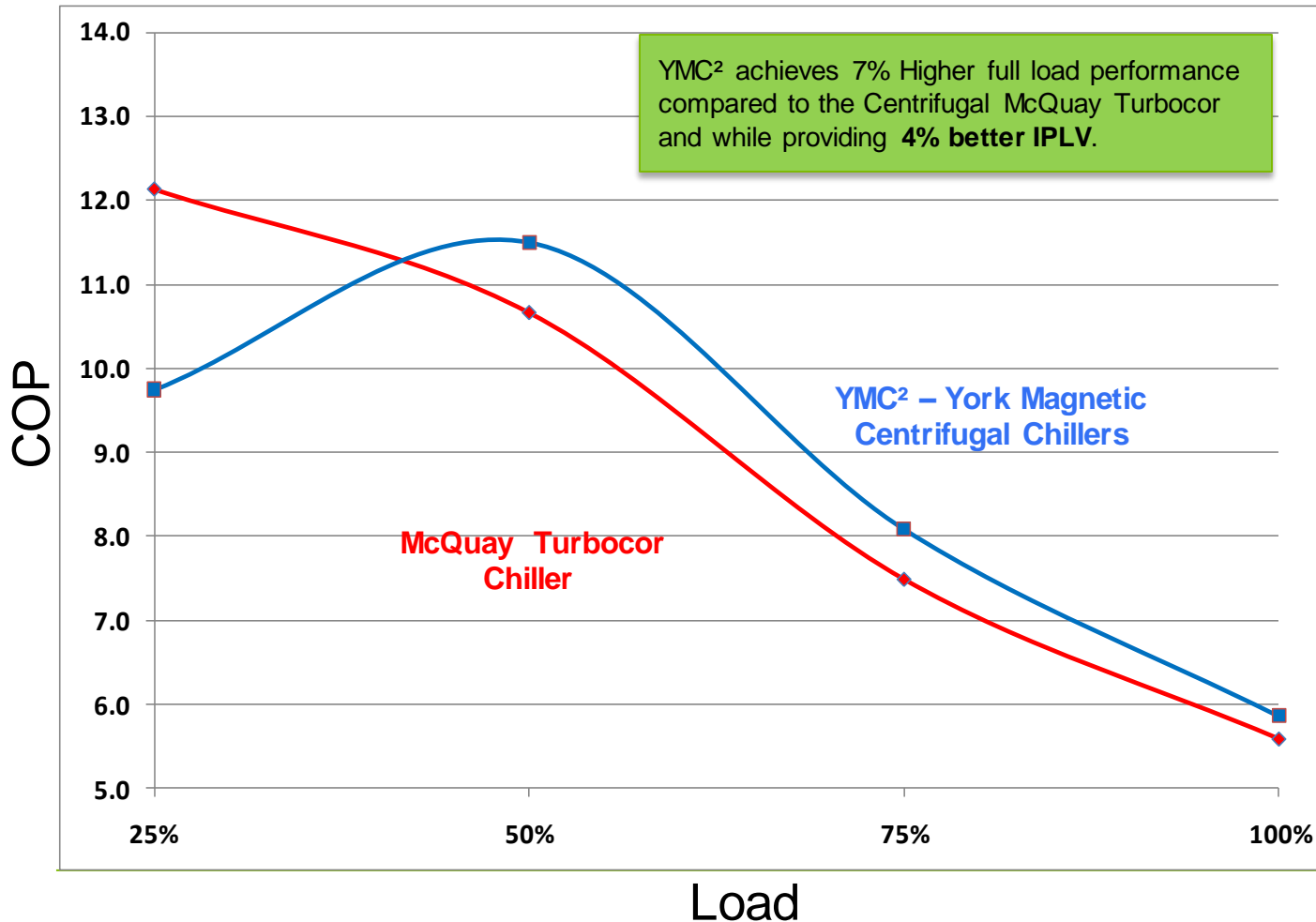

**NOT Eurovent Certified**  
AHRI Certified



**McQuay WMC Turbocor**



**YMC<sup>2</sup> – York Magnetic Centrifugal Chillers**

**Eurovent Certified**  
AHRI Certified

# YMC<sup>2</sup>

## Target Markets



# YMC<sup>2</sup> – YORK Magnetic Centrifugal Chillers (800-1950 kW)

## The YMC<sup>2</sup> is an ideal match for traditional, complex markets



### Hospitals –

Customer Requirements:

- Energy/Life Cycle Costs
- Minimal Downtime
- Sustainability



### Industrial & Process –

Customer Requirements:

- Energy/Life Cycle Costs
- Minimal Downtime
- Sustainability
- Low Maintenance
- Innovative solutions



### Real Estate / Offices –

Customer Requirements:

- Energy Efficiency
- Minimal Downtime
- Quiet Operation
- Sustainability
- Low Maintenance



Large Tonnage Chillers by Vertical  
% of total LTC Market as seen by JCI

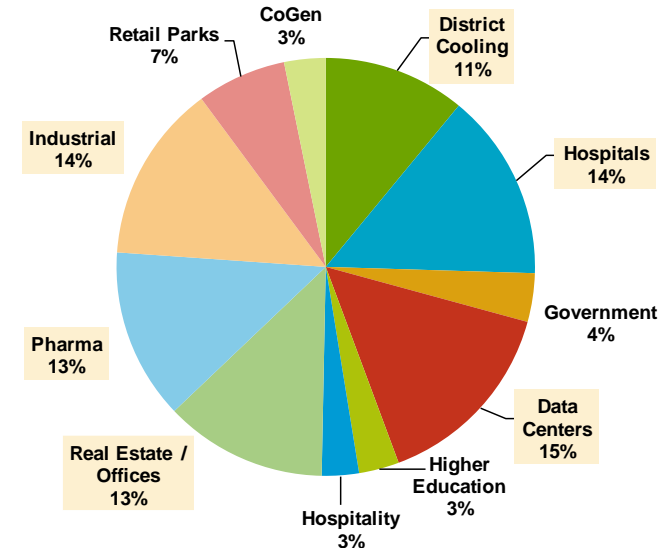

### Data Centers

Customer Requirements:

- Energy Efficiency
- Minimal Downtime
- Sustainability
- Low Maintenance

# YMC<sup>2</sup> – YORK Magnetic Centrifugal Chillers (800-1950 kW)

## Watch the replacement chiller market



- Chiller replacement business is 45% of the market.
- We currently only “see” about 1/4 of the replacement market .
- There are approximately 2.000 York brand centrifugal (SOM 31%) and 2.200 York brand water cooled chillers >700 kW (SOM 12%) installed in the European market  
(Source: Eurovent 2009)
- Whoever is servicing the equipment in this market is predisposed to secure the replacement chiller.
- The YMC<sup>2</sup> fit:
  - High efficiency
  - Quiet Operation
  - Innovative technology
  - BAS Connectivity

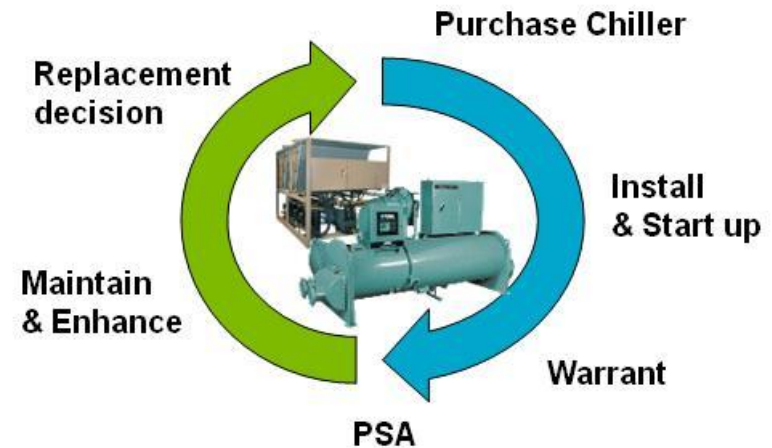

# YMC<sup>2</sup> – YORK Magnetic Centrifugal Chillers (800-1950 kW)

## The replacement market could heat up fast!



- Replacement of R22 will drive the chiller replacement business from 45% to 60% within the next 2-3 years (BSRIA, Global Insight)
- Increasing refrigerant price will demand for chillers with reduced refrigerant charge
  - ⇒ advantage of falling film evaporators
- F-gas regulation in the EU requires more frequent maintenance intervals on chillers with high refrigerant charge
  - ⇒ advantage of falling film vs flooded type
- EPBD targets and building certification demands high energy efficiency, full and part-load



YMC<sup>2</sup>

What's different?

What's the same?



# YMC<sup>2</sup> – YORK Magnetic Centrifugal Chillers (215-560 Tons / 800-1950 kW )



## What's Different, What's the Same

### ■ Mod B (Second Generation) 1280 –1950

**KW New motor family with**

- Larger radial and axial bearings
- Integrated MBC (Magnetic Bearing Controller)
- **Larger Compressors (Q5, Q6 and Q7)**
- **Second generation Hybrid Falling Film Evaporators with**
  - 75/25 Split
  - Even less refrigerant
- **Third generation capacity control**
  - Flow straightening “**Grid**”. No PRVs.
  - OptiSound™ Control, with **new quick response actuator**, and OptiSpeed™ VSD combine to provide precise capacity control
- **Standard QuickStart w/UPS** (uninterrupted power supply) for fast restarts.

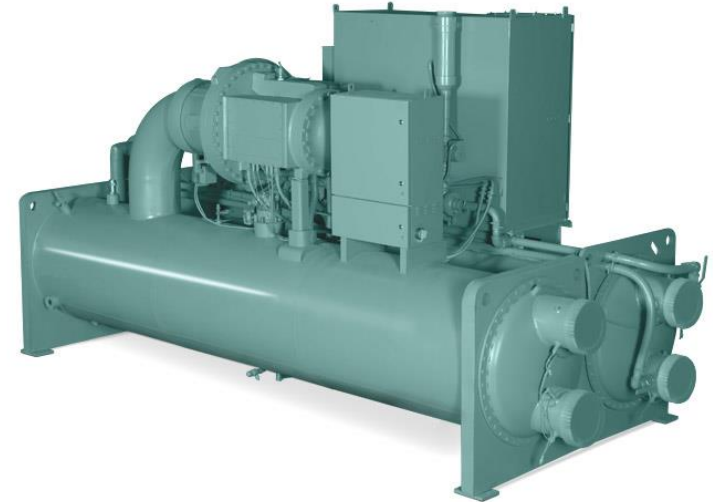

# YMC<sup>2</sup>

## Chiller Overview

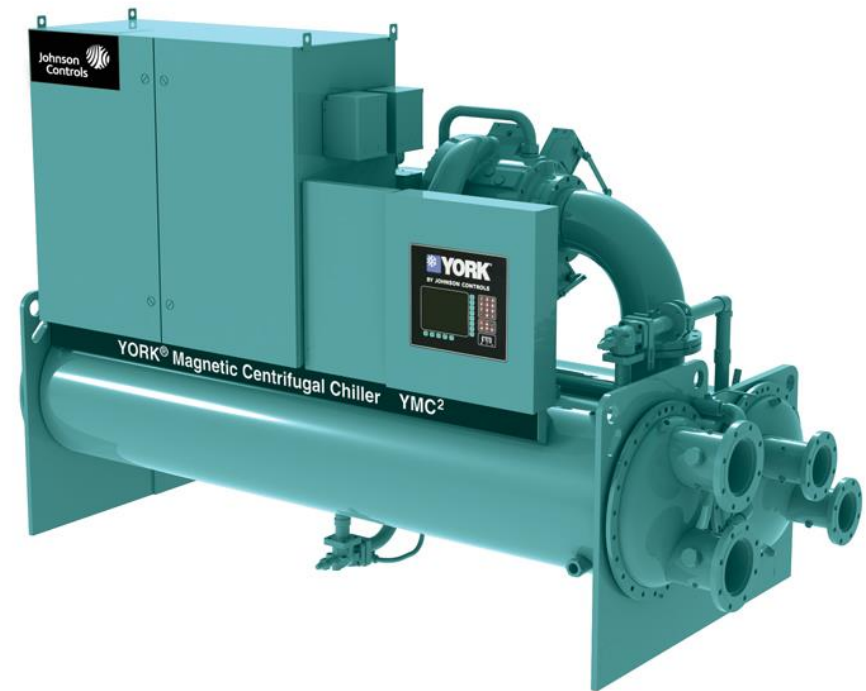

# YMC<sup>2</sup> – YORK Magnetic Centrifugal Chillers (800-1950 kW)

## Overview – **Layout**

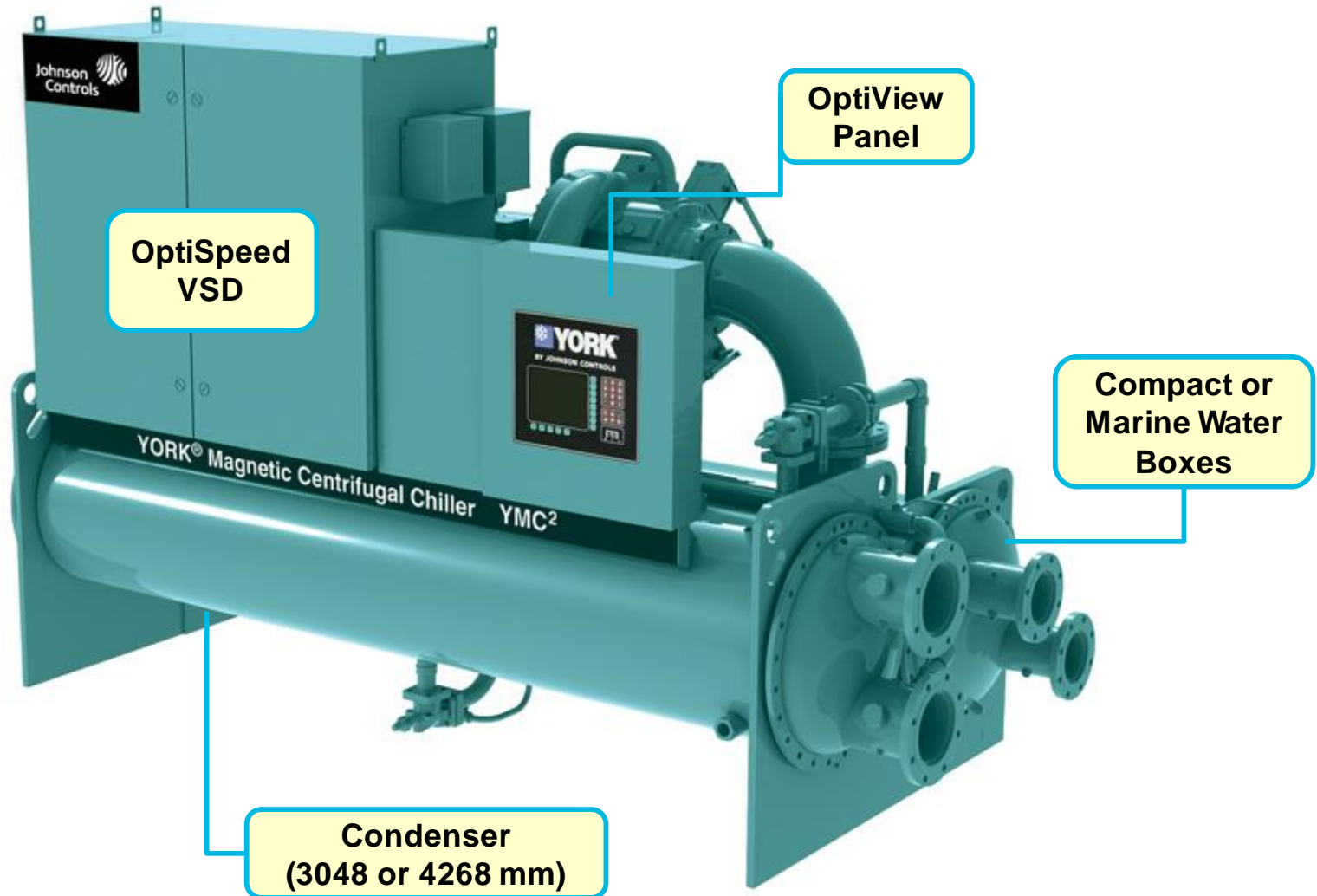

# YMC<sup>2</sup> – YORK Magnetic Centrifugal Chillers (800-1950 kW)

## Overview – Layout

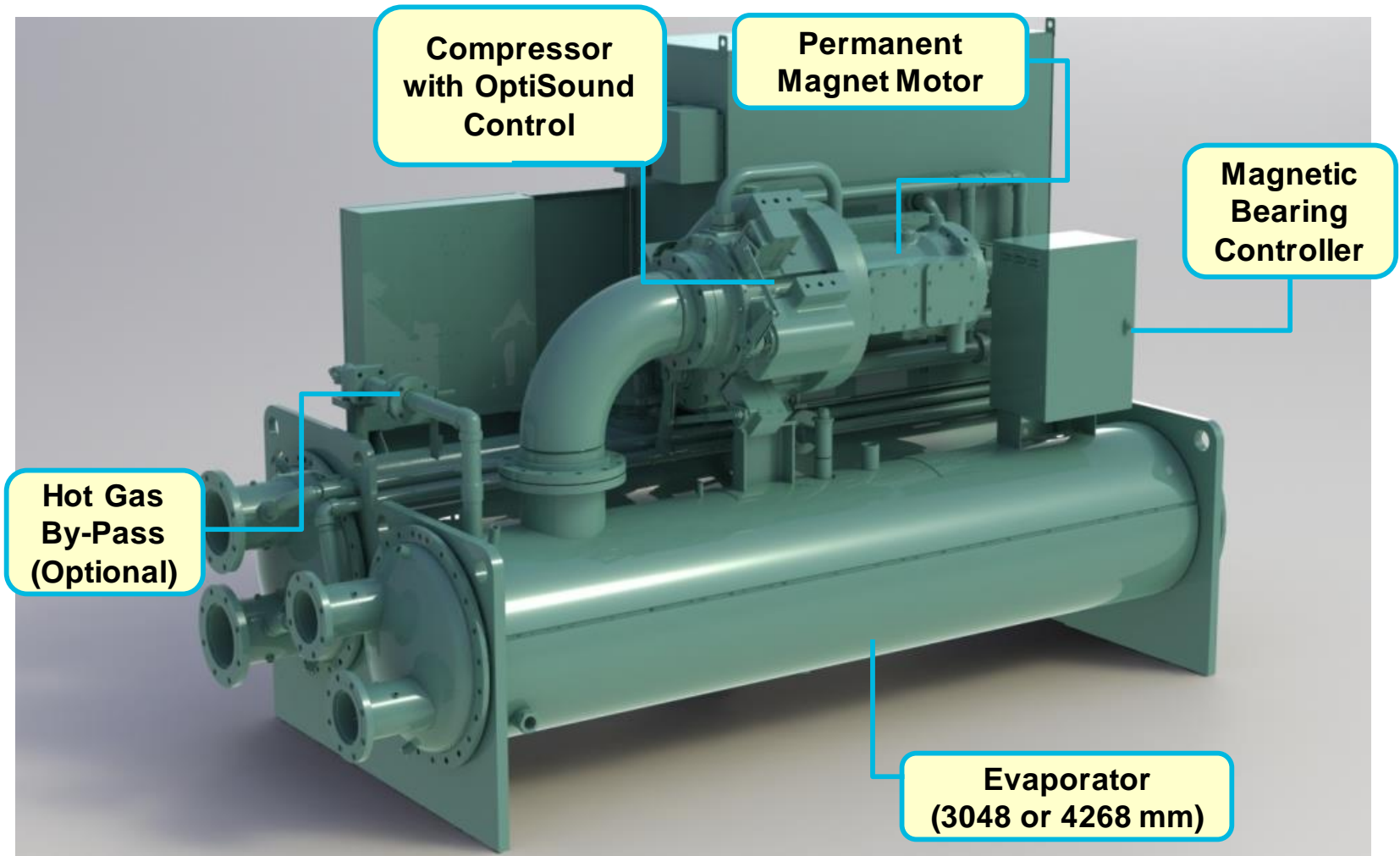

# YMC<sup>2</sup> – YORK Magnetic Centrifugal Chillers (800-1950 kW)

## Helping clients **SAVE THEIR VOICE**

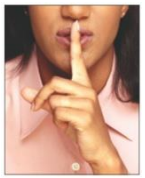

### How does the YMC<sup>2</sup> actually SOUND?

- YK sound performance (300 tons at AHRI conditions)
  - Industry leading sound
  - 79.5 dB(A) (sound pressure level at 1m)



- YMC<sup>2</sup> sound performance (300 tons at AHRI conditions)
  - The new standard
  - 70 dB(A) (sound pressure level at 1m)



# YMC<sup>2</sup> – YORK Magnetic Centrifugal Chillers (800-1950 kW)

## Comparison – vs. YK



- Control Panel on Evaporator Side
- VSD on Evaporator Side
- No Motor Cooling System
- Open Motor Drive
- Gear Driven



- Control Panel on Condenser Side
- VSD on Condenser Side
- No Oil Management System
- Hermetic Motor
- Direct Drive Design

# YMC<sup>2</sup> – YORK Magnetic Centrifugal Chillers (800-1950 kW)

## Driveline Design – Permanent Magnet Motor

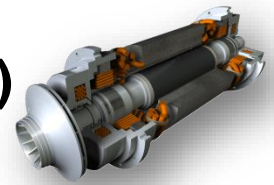

### Driveline Technology

#### What is a PM Motor?

High speed Permanent Magnet synchronous motor levitated by magnetic bearings

#### What are the benefits of PM Motors?

Superior efficiency, quiet operation, excellent durability by design

##### ■ Direct Drive

- Impeller is mounted directly to the shaft end eliminating the need for additional gears and shafts

##### ■ Frictionless

- Ultra Quiet Operation
- Virtually no structural vibration

##### ■ Oil Free -- eliminating

- The need for oil pumps, coolers, filters, reservoirs etc.
- The possibility of oil loss – maintaining efficiency

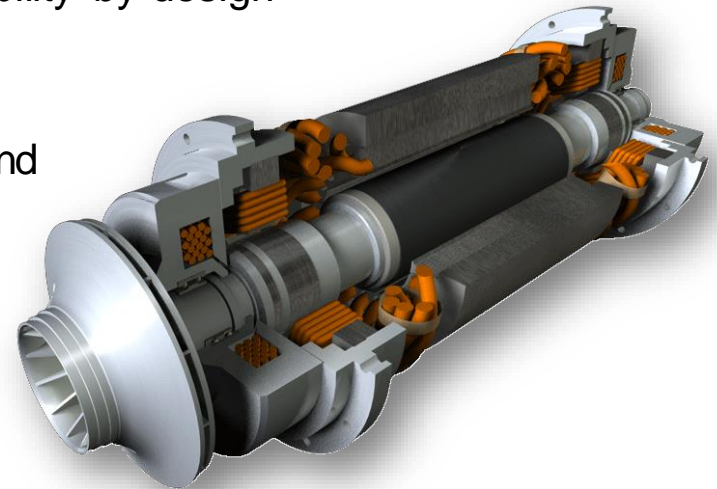

# YMC<sup>2</sup> – YORK Magnetic Centrifugal Chillers (800-1950 kW) Driveline Design – Permanent Magnet Motor

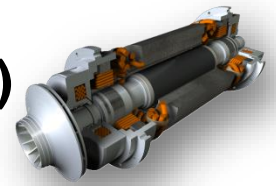

Proven aerodynamics combined with efficient motor technology

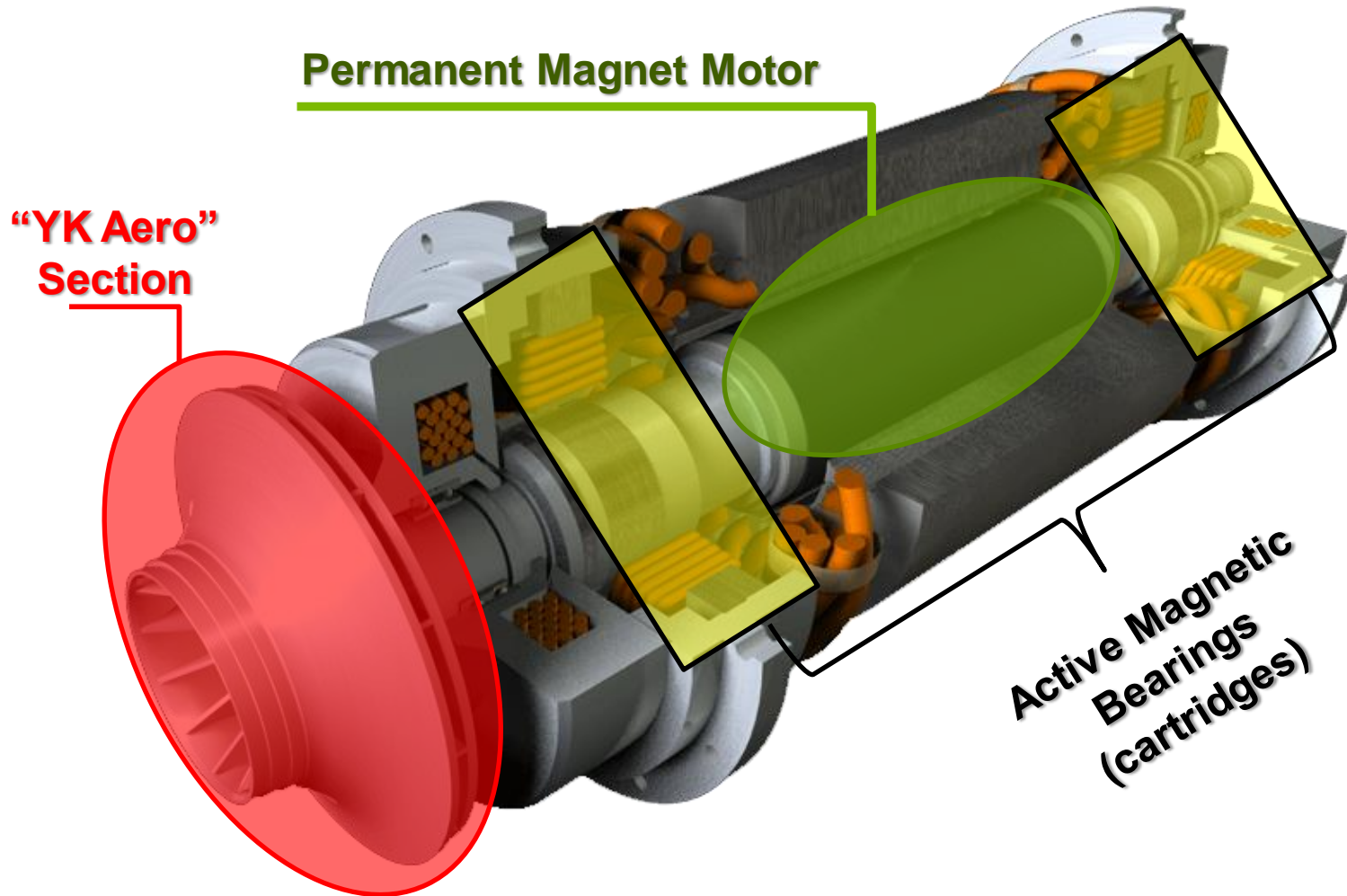

# YMC<sup>2</sup> – YORK Magnetic Centrifugal Chillers (800-1950 kW)

## Driveline Design – Permanent Magnet Motor

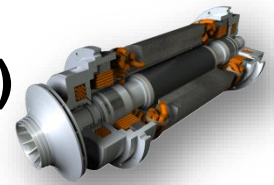

### Motor Components

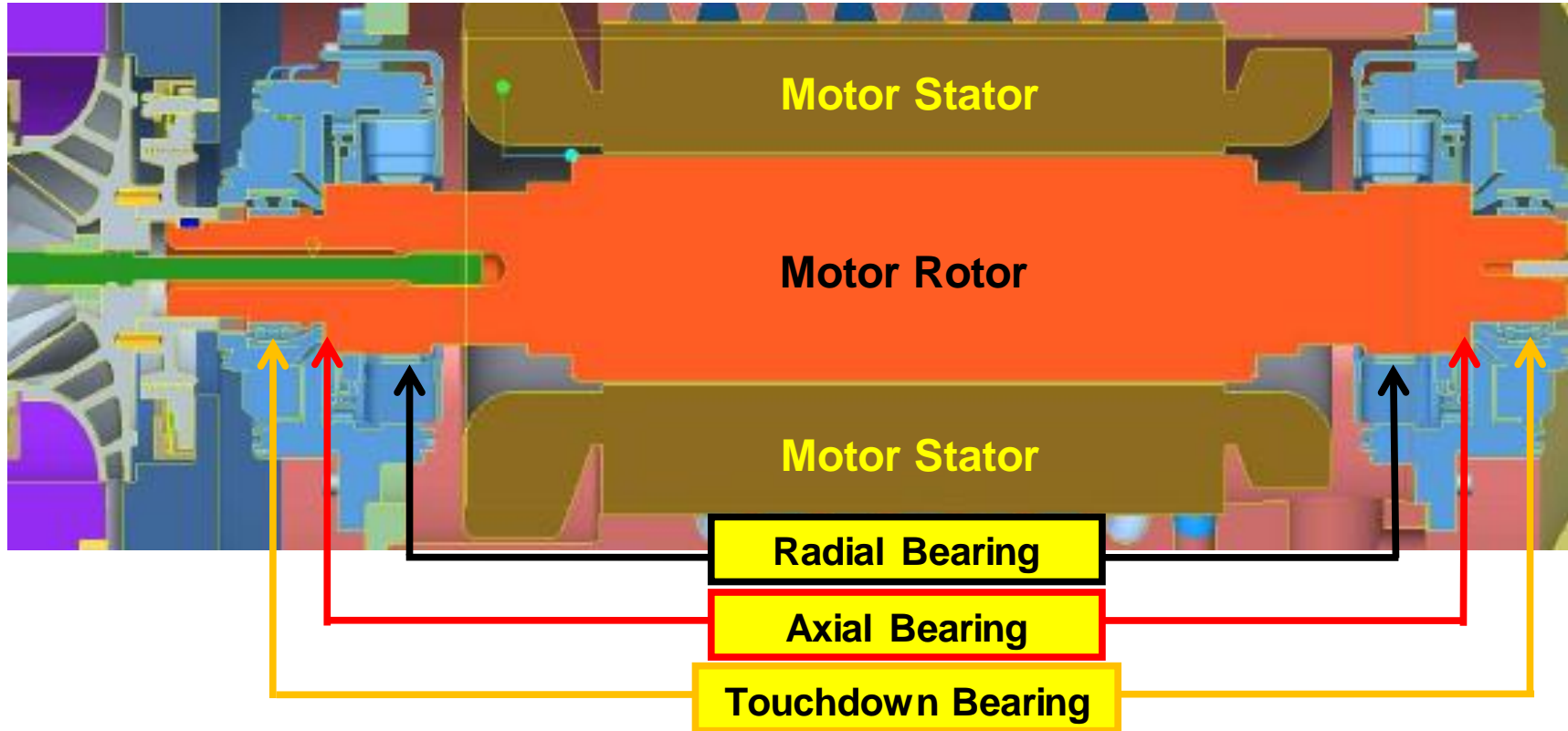

- During operation the rotor is suspended (levitated) and there is no contact between the rotor and the bearings
- The YMC<sup>2</sup>'s motor rotor is supported on magnetic bearings with “touchdown” ball for backup

# YMC<sup>2</sup> – YORK Magnetic Centrifugal Chillers (800-1950 kW)

## Driveline Design – Permanent Magnet Motor

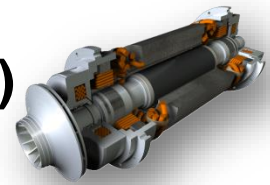

### Bearing Cartridge

- Cartridge consists of
  - Radial bearing coils and sensors
  - Axial bearing coils and sensors
  - Touchdown bearing (Can carry radial and axial loads)
- Bearing life expectancy:
  - Magnetic bearings = for the life of the product as long as they are cooled properly
  - Touchdown bearings = replacement is recommended after 20 “hard” Touchdowns.

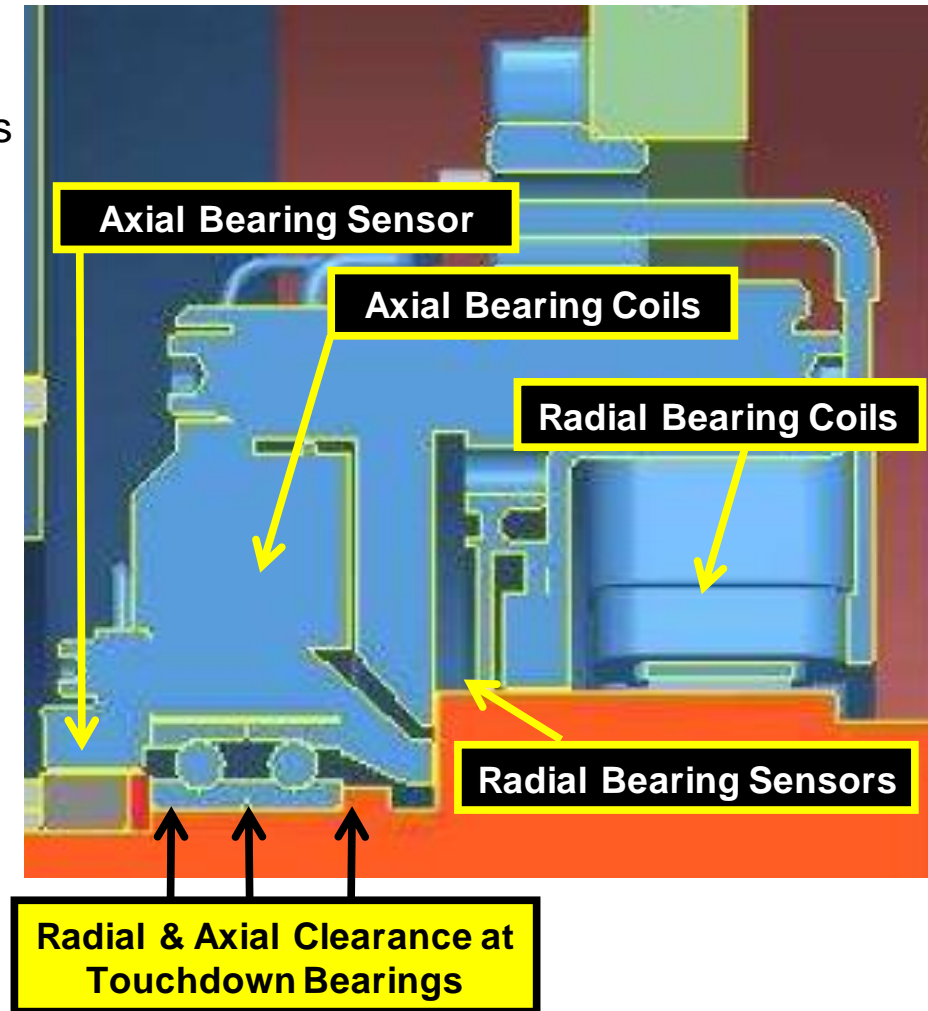

# YMC<sup>2</sup> – YORK Magnetic Centrifugal Chillers (800-1950 kW) Driveline Design – Permanent Magnet Motor

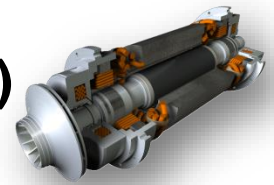

## Operating principle of magnetic bearings

- Magnetic bearings operate by attracting the shaft
- Multiple bearing position sensors ensure proper operational alignments
- Corrects itself 1500 times per second

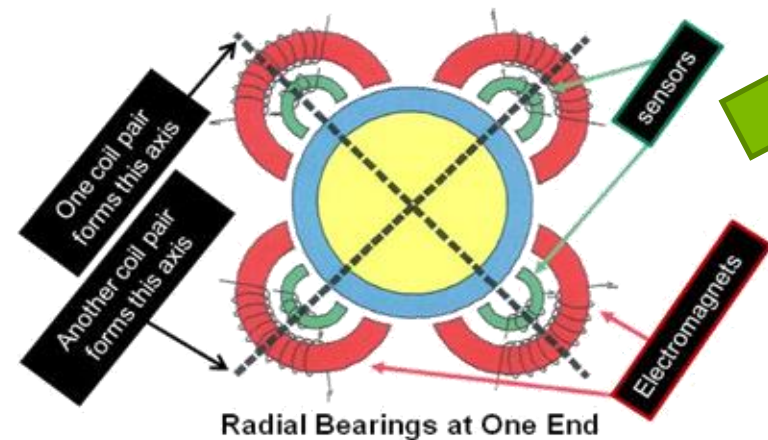
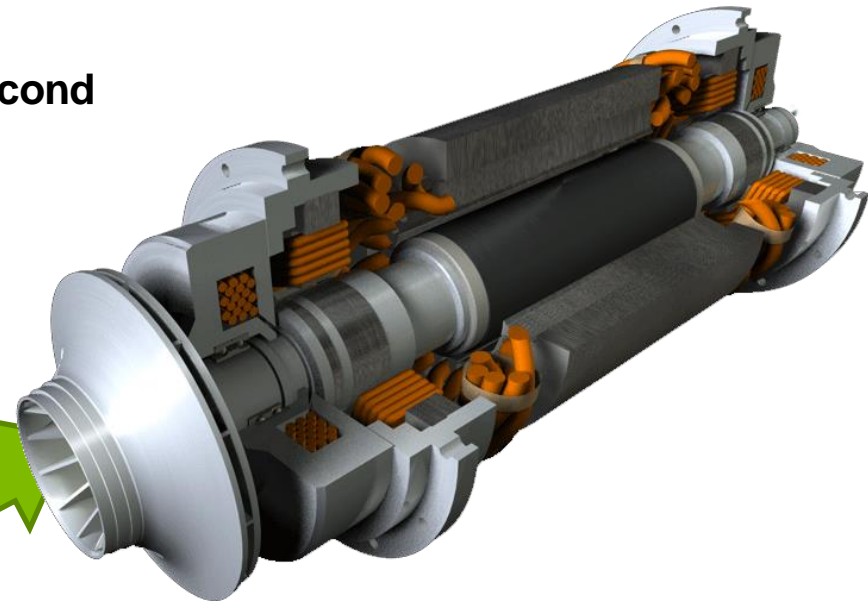

# YMC<sup>2</sup> – YORK Magnetic Centrifugal Chillers (800-1950 kW) Driveline Design – Permanent Magnet Motor

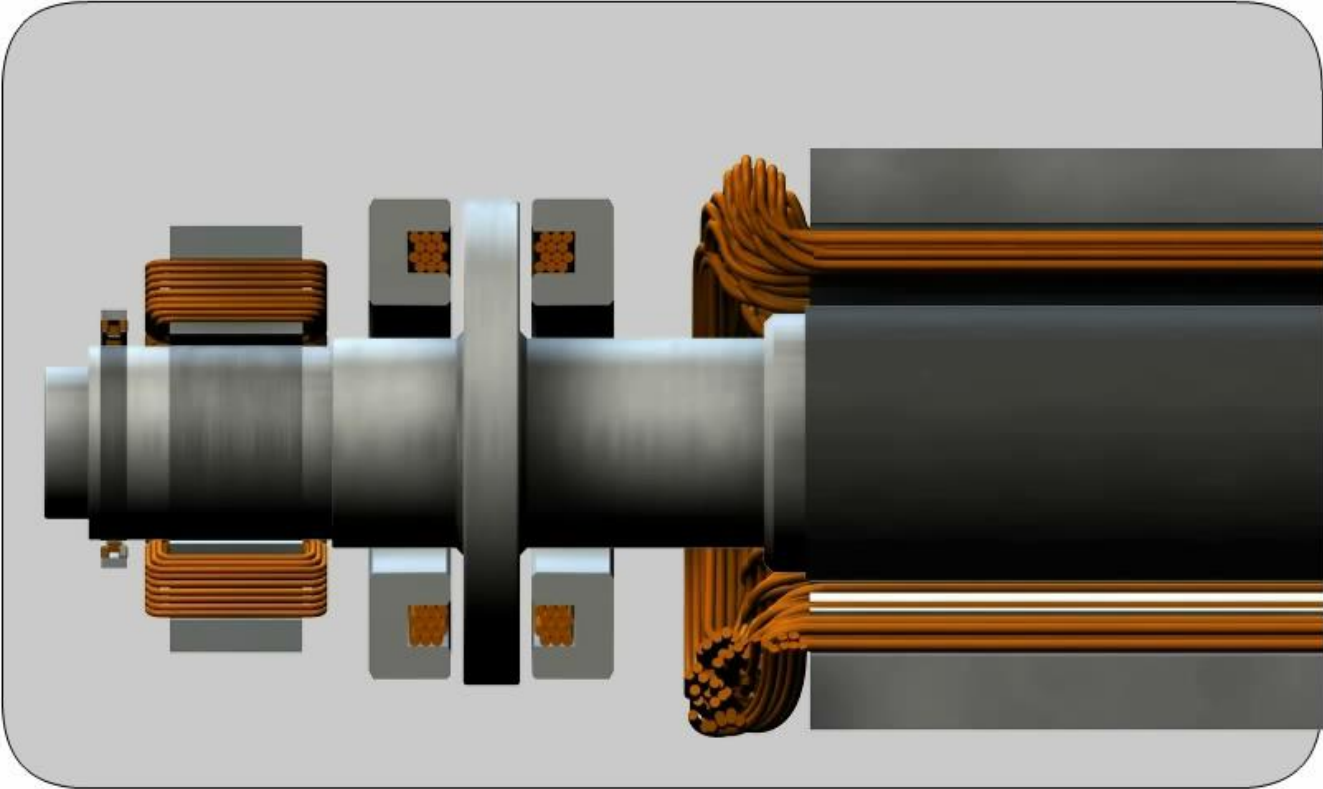
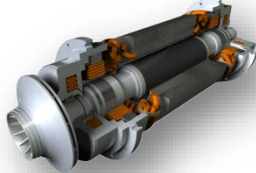

- 1
- 2
- 3
- 4
- 5
- 6
- 7
- 8
- 9
- 10

# YMC<sup>2</sup> – YORK Magnetic Centrifugal Chillers (800-1950 kW) Driveline Design – Permanent Magnet Motor

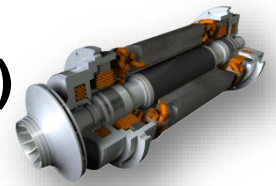

## ● THE POSITION SENSORS

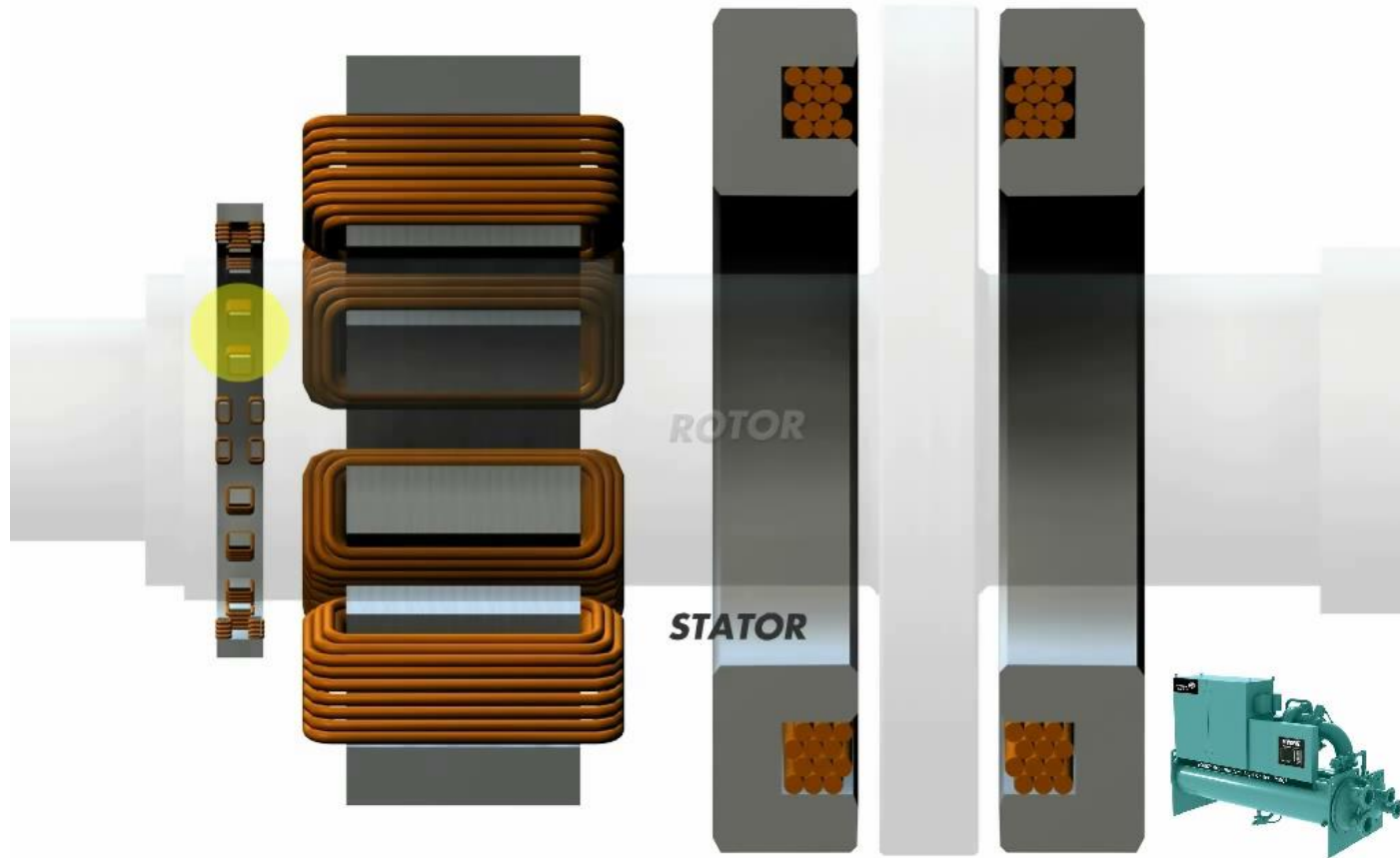

# YMC<sup>2</sup>

## Falling Film Technology



# YMC<sup>2</sup> – YORK Magnetic Centrifugal Chillers (800-1950 kW) Falling Film Technology



## How does the YMC<sup>2</sup> improve EFFICIENCY & SUSTAINABILITY?

- **Improved efficiency through**
  - Superior heat transfer
  - Efficient use of space (ability to use smaller length shells while still providing superior performance)
  
- **Improved sustainability through**
  - Environmentally friendly design
    - Up to 30% less HFC-134a refrigerant charge
    - Leak tight design with fewer joints
    - Over 50% fewer connections than current YK
    - Elimination of the oil system
  - Superior efficiency which reduces the strain on local utilities and ultimately the consumption of natural resources

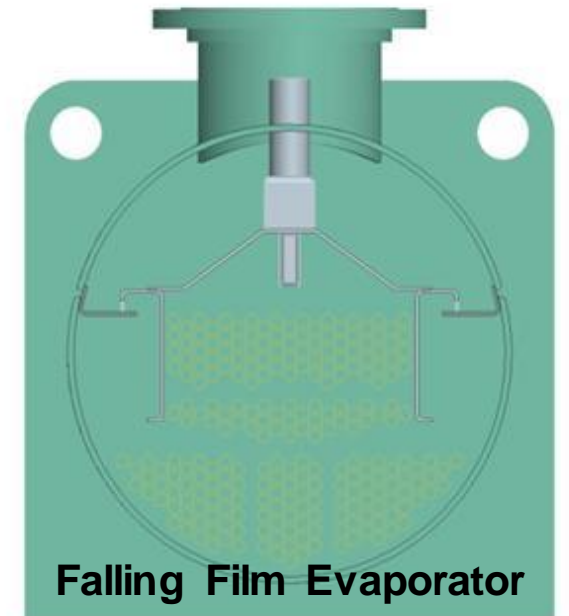
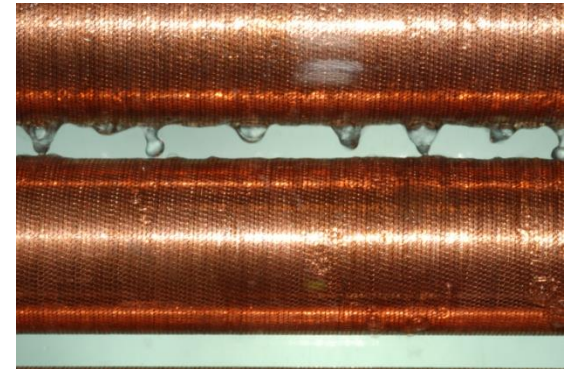

# YMC<sup>2</sup> – YORK Magnetic Centrifugal Chillers (800-1950 kW) Falling Film Technology



## Liquid Line

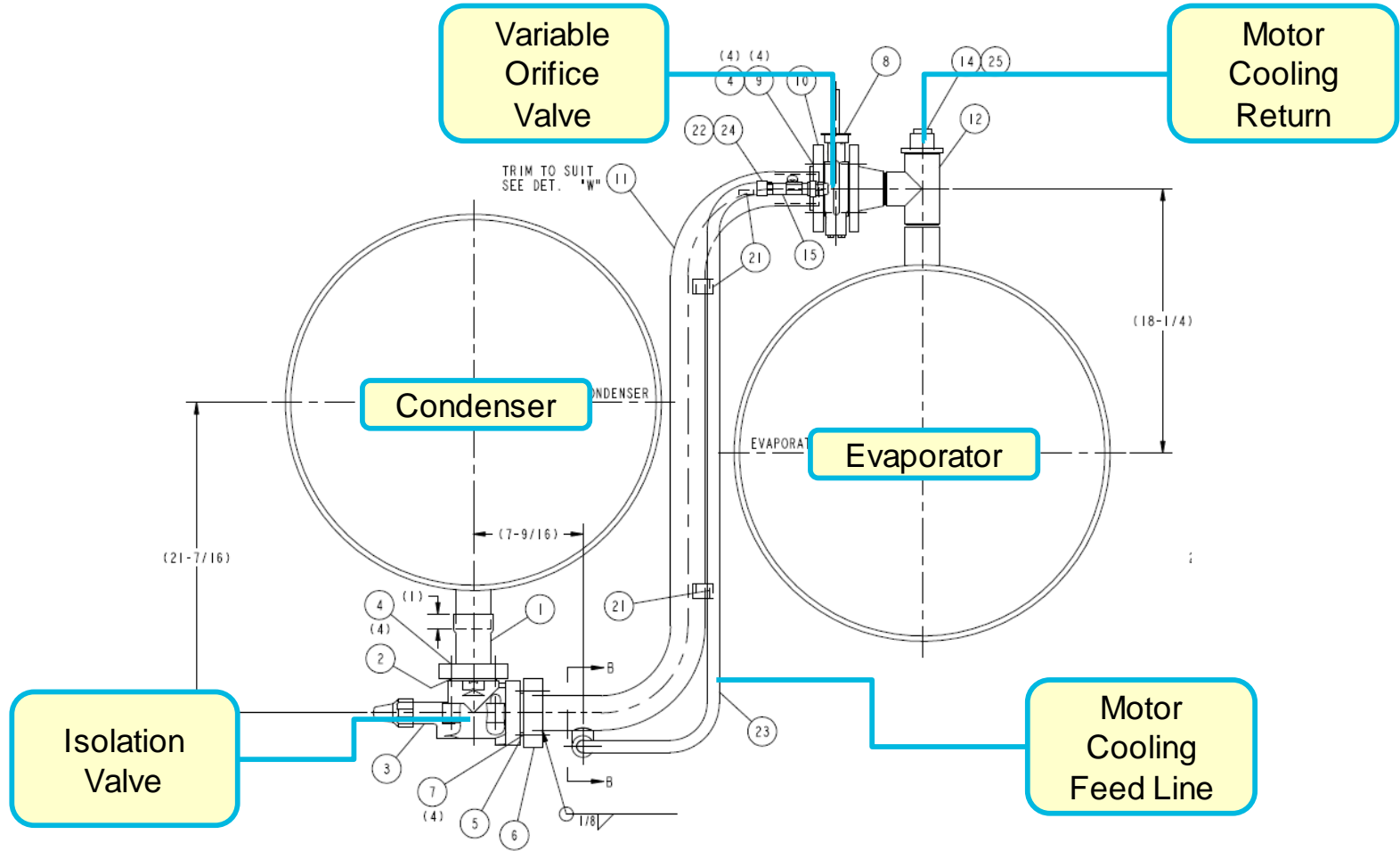

# YMC<sup>2</sup> – YORK Magnetic Centrifugal Chillers (800-1950 kW) Falling Film Technology



## Flooded vs. Falling Film – How it works

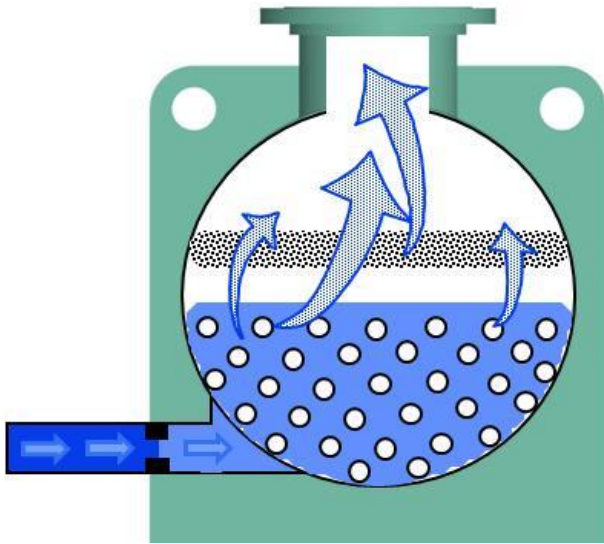

**Flooded Evaporator**

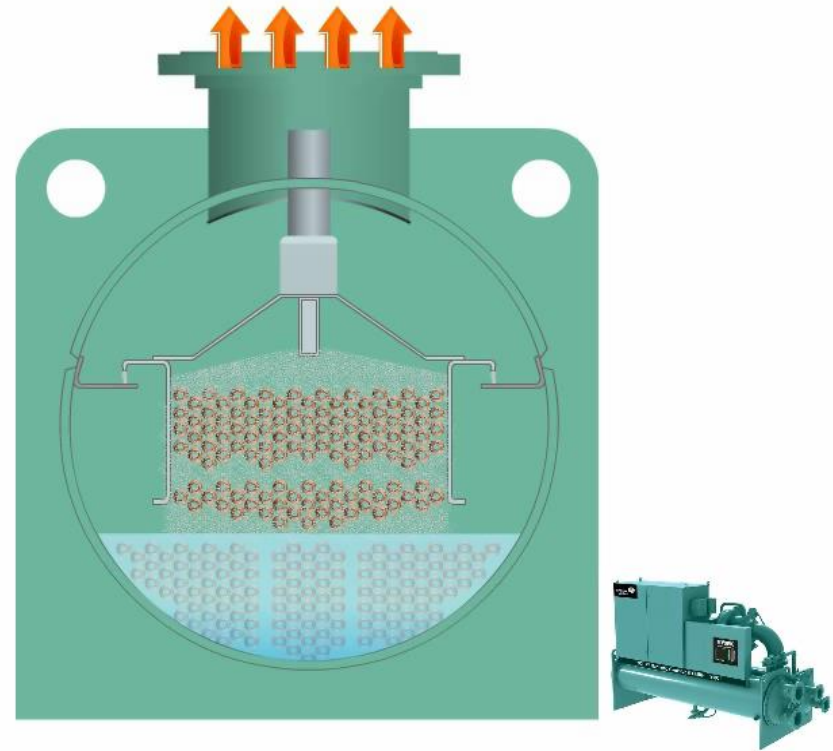

**Falling Film Evaporator**

# YMC<sup>2</sup> – YORK Magnetic Centrifugal Chillers (800-1950 kW) Falling Film Technology

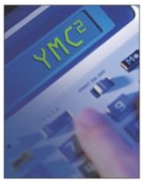

## Hybrid Falling Film Components

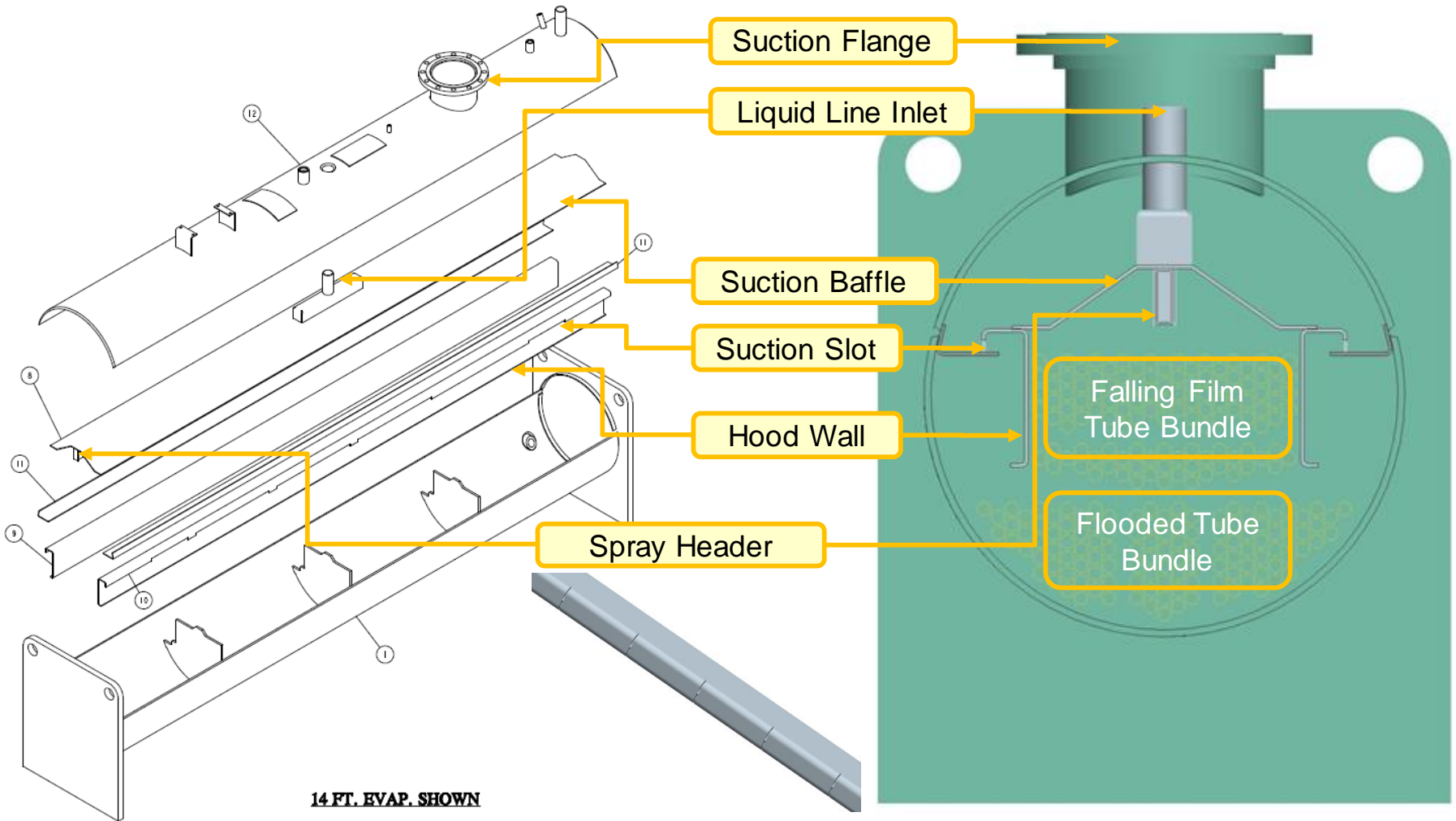

# YMC<sup>2</sup>

## Next Steps: Local

