



CENTRIFUGAL LIQUID CHILLERS

INSTALLATION AND REASSEMBLY

Supersedes: 160.84-N1 (813)

Form 160.84-N1 (913)

YMC² MODEL B WITH OPTIVIEW™ CONTROL CENTER



LD17194

R-134a

Issue Date:
September 30, 2013



IMPORTANT!

READ BEFORE PROCEEDING!

GENERAL SAFETY GUIDELINES

This equipment is a relatively complicated apparatus. During installation, operation maintenance or service, individuals may be exposed to certain components or conditions including, but not limited to: refrigerants, materials under pressure, rotating components, and both high and low voltage. Each of these items has the potential, if misused or handled improperly, to cause bodily injury or death. It is the obligation and responsibility of operating/service personnel to identify and recognize these inherent hazards, protect themselves, and proceed safely in completing their tasks. Failure to comply with any of these requirements could result in serious damage to the equipment and the property in

which it is situated, as well as severe personal injury or death to themselves and people at the site.

This document is intended for use by owner-authorized operating/service personnel. It is expected that these individuals possess independent training that will enable them to perform their assigned tasks properly and safely. It is essential that, prior to performing any task on this equipment, this individual shall have read and understood this document and any referenced materials. This individual shall also be familiar with and comply with all applicable governmental standards and regulations pertaining to the task in question.

SAFETY SYMBOLS

The following symbols are used in this document to alert the reader to specific situations:



Indicates a possible hazardous situation which will result in death or serious injury if proper care is not taken.



Identifies a hazard which could lead to damage to the machine, damage to other equipment and/or environmental pollution if proper care is not taken or instructions are not followed.



Indicates a potentially hazardous situation which will result in possible injuries or damage to equipment if proper care is not taken.

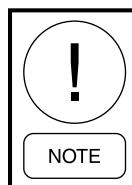

Highlights additional information useful to the technician in completing the work being performed properly.



External wiring, unless specified as an optional connection in the manufacturer's product line, is not to be connected inside the OptiView™ cabinet. Devices such as relays, switches, transducers and controls and any external wiring must not be installed inside the cabinet. All wiring must be in accordance with Johnson Controls' published specifications and must be performed only by a qualified electrician. Johnson Controls will NOT be responsible for damage/problems resulting from improper connections to the controls or application of improper control signals. Failure to follow this warning will void the manufacturer's warranty and could cause serious damage to property or personal injury.

CHANGEABILITY OF THIS DOCUMENT

In complying with Johnson Controls' policy for continuous product improvement, the information contained in this document is subject to change without notice. Johnson Controls makes no commitment to update or provide current information automatically to the manual owner. Updated manuals, if applicable, can be obtained by contacting the nearest Johnson Controls Service office or accessing the Johnson Controls QuickLIT website at <http://cgproducts.johnsoncontrols.com>.

Operating/service personnel maintain responsibility for the applicability of these documents to the equipment. If there is any question regarding the applicability of

these documents, the technician should verify whether the equipment has been modified and if current literature is available from the owner of the equipment prior to performing any work on the chiller.

CHANGE BARS

Revisions made to this document are indicated with a line along the left or right hand column in the area the revision was made. These revisions are to technical information and any other changes in spelling, grammar or formatting are not included.

ASSOCIATED LITERATURE

MANUAL DESCRIPTION	FORM NUMBER
Chiller Operations & Maintenance	160.84-OM1
Unit Installation Checklist and Request for Startup	160.84-CL1
Unit Startup Checklist	160.84-CL2
Field Connections Diagram	160.84-PW1
Field Control, Wiring and MBC Diagrams	160.84-PW2
VSD Wiring Diagrams	160.84-PW3
Centrifugal Chiller Long Term Storage	50.20-NM5
All Products - Replacement Parts Electrical Connectors	50.20-RP1
All Products - Replacement Parts Fittings	50.20-RP2

SYSTEM NOMENCLATURE

Y M C 2 - S 0756 A B

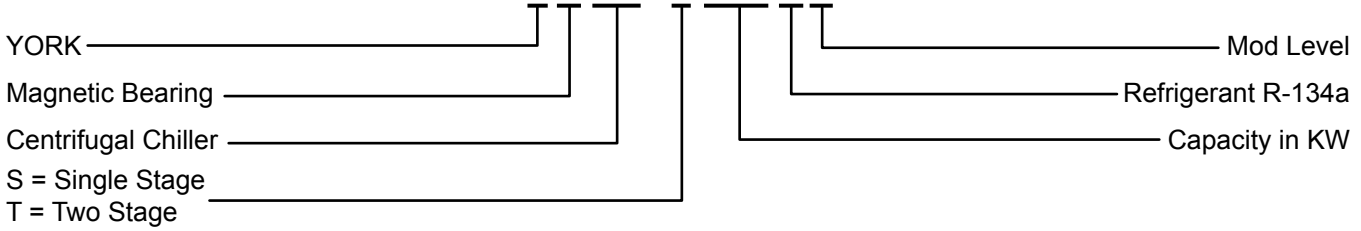

COMPRESSOR NOMENCLATURE

M1 B - 197 F A C

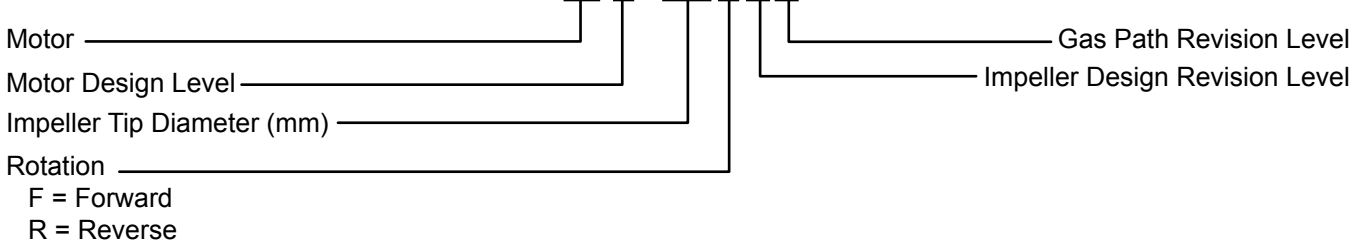

VESSEL NOMENCLATURE

E A 25 14 271 B R 1 1 F C R

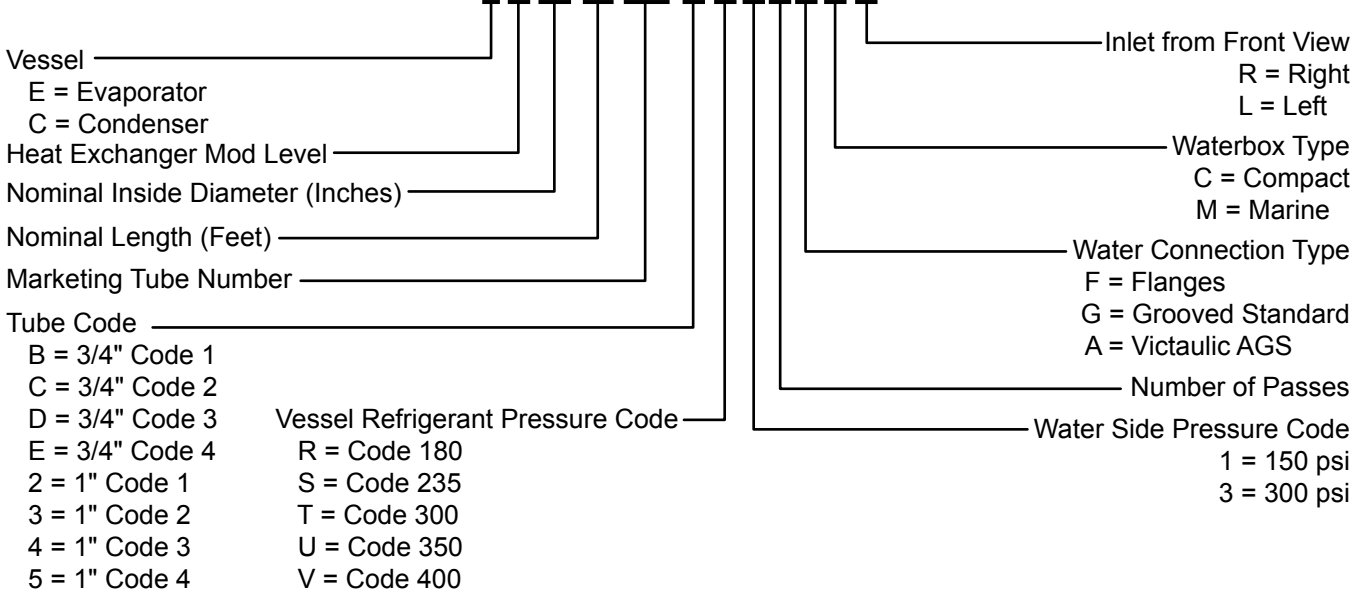

VARIABLE SPEED DRIVE NOMENCLATURE

HYP 774 X H 15 D - 40

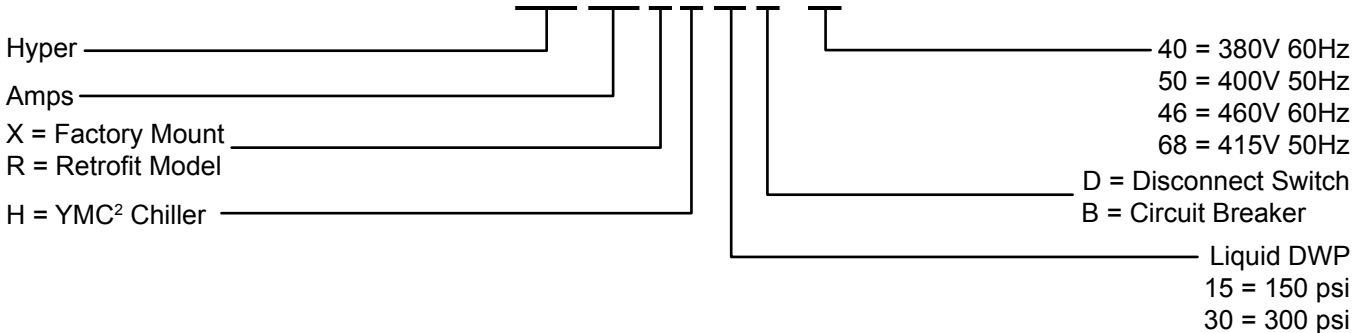

TABLE OF CONTENTS

SECTION 1 - OVERVIEW	9
General.....	9
Component Combinations.....	9
Inspection – Damage – Shortage.....	10
Chiller Data Plate	10
YMC ² Shipment Forms	10
Form 1	11
Form 2	11
Form 3	11
Form 7	12
Form 9.....	13
Form 10	13
Form 11	14
 SECTION 2 - RIGGING AND LIFTING	 15
Form 1 Total Weight	15
Form 1 Shipment.....	15
Unit Rigging.....	15
Form 2 Total Weight	17
Form 2 Shipment.....	17
Unit Rigging.....	17
Form 3 Shipment.....	18
Shells.....	18
Compressor Motor Assembly	18
Variable Speed Drive (VSD).....	19
Power Panel.....	20
OptiView™ Control Center	20
Form 7 Shipment.....	21
Condenser.....	21
Evaporator	22
Compressor Motor Assembly	22
Variable Speed Drive (VSD).....	22
Power Panel.....	23
OptiView™ Control Center	23
Form 9 Shipment.....	24
Unit Rigging.....	25
Variable Speed Drive (VSD).....	25
Form 10 Shipment.....	26
Unit Rigging.....	26
Variable Speed Drive (VSD).....	26
Form 11 Shipment.....	27
Condenser Assembly	27
Evaporator Assembly	29
OptiView™ Control Center	29

TABLE OF CONTENTS (CONT'D)

SECTION 3 - INSTALLATION	31
Overview	31
Determine Location	31
Foundation Requirements	31
Clearance Requirements	31
Rig Unit To Final Location.....	31
Install Isolators	31
Neoprene Isolator Pads.....	31
Install Optional Spring Isolators.....	34
Make Connections.....	36
Piping Connections	36
Refrigerant Relief Piping	38
Unit Piping.....	39
Control Wiring.....	39
Power Wiring	39
Supplied Variable Speed Drive.....	39
Apply Insulation	39
Installation Check – Request For Startup Service.....	39
 SECTION 4 - REASSEMBLY	 41
FORM 3 and FORM 7 Reassembly	41
FORM 9 and FORM 10 Reassembly	48
FORM 11 Reassembly	50
Refrigerant Tubing Reassembly	52
Assembly of Straight Thread O-ring Port Fittings.....	52
Assembly of O-ring Face Seal Fittings.....	53
 SECTION 5 - DIMENSIONS, NOZZLE ARRANGEMENTS AND WEIGHTS	 55
Compressor Unit Dimensions.....	55
Evaporator 150 & 300 PSI Compact Water Boxes.....	57
Condenser 150 & 300 PSI Compact Water Boxes.....	59
Evaporator 150 & 300 PSI Marine Water Boxes	61
Condenser 150 PSI Marine Water Boxes.....	65
Condenser 150 & 300 PSI Marine Water Boxes DIMENSIONS	66
Weights.....	67

LIST OF FIGURES

FIGURE 1 - YMC ² Chiller Components	9
FIGURE 2 - Form 1 and 2 Rigging With Side Spreader Bar	16
FIGURE 3 - Form 1 and 2 Rigging Without Side Spreader Bar	16
FIGURE 4 - Driveline Rigging.....	18
FIGURE 5 - Form 3 Rigging Without Side Spreader Bars.....	19
FIGURE 6 - Variable Speed Drive Rigging.....	19
FIGURE 7 - Power Panel	20
FIGURE 8 - OptiView Control Center	20
FIGURE 9 - Form 7 Rigging With Side Spreader Bars.....	21
FIGURE 10 - Driveline Rigging.....	22
FIGURE 11 - Variable Speed Drive Rigging	23
FIGURE 12 - Power Panel	23
FIGURE 13 - OptiView Control Center	24
FIGURE 14 - Form 9 And 10 Rigging With Side Spreader Bars	24
FIGURE 15 - Form 9 And 10 Rigging Without Side Spreader Bars	25
FIGURE 16 - Variable Speed Drive Rigging.....	26
FIGURE 17 - Variable Speed Drive Rigging.....	27
FIGURE 18 - Form 11 Condenser Assembly Rigging With Side Spreader Bars.....	28
FIGURE 19 - Form 11 Evaporator Assembly Rigging With Side Spreader Bars.....	28
FIGURE 20 - OptiView Control Center	29
FIGURE 21 - Neoprene Isolators	32
FIGURE 22 - Neoprene Isolators	33
FIGURE 23 - Spring Isolators	34
FIGURE 24 - Spring Isolators.....	35
FIGURE 25 - Pressure Relief Piping	36
FIGURE 26 - Typical Refrigerant Vent Piping.....	37
FIGURE 27 - Schematic Of A Typical Piping Arrangement	37
FIGURE 28 - Unit Insulation	40
FIGURE 29 - Shell Reassembly.....	41
FIGURE 30 - YMC ² Piping Reassembly Hardware Identification	43
FIGURE 31 - YMC ² Form 3 Reassembly Hardware Identification.....	44
FIGURE 32 - YMC ² Form 7 Reassembly Hardware Identification.....	45
FIGURE 33 - VSD Mounting Hardware Identification.....	46
FIGURE 34 - Power and Control Panel Mounting Hardware Identification	47
FIGURE 35 - YMC ² Form 9 and Form 10 Reassembly Hardware Identification	49
FIGURE 36 - Shell Reassembly.....	50
FIGURE 37 - Refrigerant Piping.....	50
FIGURE 38 - YMC ² Form 11 Reassembly Hardware Identification.....	51
FIGURE 39 - Adjustable End Fitting	52
FIGURE 40 - Back off Locknut	52
FIGURE 41 - Screw Fitting Into Port	52
FIGURE 42 - Torque Fitting	53
FIGURE 43 - SAE or ISO 6149 Straight Thread O-ring Port.....	53
FIGURE 44 - Dimensions - 197 & 246 Compressor Units Ft-In (Mm).....	56

LIST OF FIGURES (CONT'D)

FIGURE 45 - Evaporator - Compact Water Boxes (1-Pass Nozzle Arrangements)	57
FIGURE 46 - Evaporator - Compact Water Boxes (2-Pass Nozzle Arrangements)	57
FIGURE 47 - Evaporator - Compact Water Boxes (3-Pass Nozzle Arrangements)	57
FIGURE 48 - Evaporator - 150 & 300 PSI Compact Water Boxes	58
FIGURE 49 - Condenser - Compact Water Boxes (1-Pass Nozzle Arrangements)	59
FIGURE 50 - Condenser - Compact Water Boxes (3-Pass Nozzle Arrangements)	59
FIGURE 51 - Condenser - Compact Water Boxes (2-Pass Nozzle Arrangements)	59
FIGURE 52 - Condenser - 150 & 300 PSI Compact Water Boxes	60
FIGURE 53 - Evaporator - Marine Water Boxes (1-Pass Nozzle Arrangements)	61
FIGURE 54 - Evaporator - Marine Water Boxes (2-Pass Nozzle Arrangements)	61
FIGURE 55 - Evaporator - Marine Water Boxes (3-Pass Nozzle Arrangements)	61
FIGURE 56 - Evaporator - 150 and 300 PSI Marine Water Boxes	63
FIGURE 57 - Condenser - 150 and 300 PSI Marine Water Boxes	64
FIGURE 58 - Condenser - Marine Water Boxes (1-Pass Nozzle Arrangements)	65
FIGURE 59 - Condenser - Marine Water Boxes (2-Pass Nozzle Arrangements)	65
FIGURE 60 - Condenser - Marine Water Boxes (3-Pass Nozzle Arrangements)	65

LIST OF TABLES

TABLE 1 - Compressor Motor Weights	18
TABLE 2 - Variable Speed Drive Weights	19
TABLE 3 - Power Panel	20
TABLE 4 - Control Panel Weights	20
TABLE 5 - Compressor Motor Weights	22
TABLE 6 - Variable Speed Drive Weights	22
TABLE 7 - Power Panel	23
TABLE 8 - Control Panel Weights	23
TABLE 9 - Variable Speed Drive Weights	25
TABLE 10 - Variable Speed Drive Weights	26
TABLE 11 - Control Panel Weights	29
TABLE 12 - Assembly Torque Metric for Metric Tube Fittings	42
TABLE 13 - Assembly Torque English for SAE Tube Fittings	42
TABLE 14 - Re-Assembly Torque Values	43
TABLE 15 - Approximate Evaporator Weights 150 PSI Compact Water Boxes*	66
TABLE 16 - Approximate Condenser Weights 150 PSI Compact Water Boxes*	66
TABLE 17 - Approximate Variable Speed Drive (VSD) Weights	67
TABLE 18 - Approximate Driveline Weights	67
TABLE 19 - Approximate Refrigerant & Water Weight	67

SECTION 1 - OVERVIEW

GENERAL

This manual provides instructions for rigging and installing a YMC² Liquid Chilling Unit.

Chillers can be shipped as a single factory assembled, piped, wired package, requiring a minimum of field labor to make chilled water connections, condenser water connections, refrigerant atmospheric relief connections, and electrical power connections. (Refrigerant charges shipped separately unless optional condenser isolation valves are ordered.)

They can also be shipped dismantled when required by rigging conditions, but it is generally more economical to enlarge access openings to accommodate the factory assembled unit. Chillers that are shipped dismantled **MUST** be field-assembled under the supervision of a Johnson Controls representative, but otherwise installation will be as described in this manual.

COMPONENT COMBINATIONS

Figure 1 identifies the major components of the YMC² Chiller. The chiller is customized based on the selected combination of Motor, Compressor, Evaporator, and Condenser. *Section 5 - Dimensions, Nozzle Arrangements And Weights* lists all of the allowable YMC² Chiller combinations.

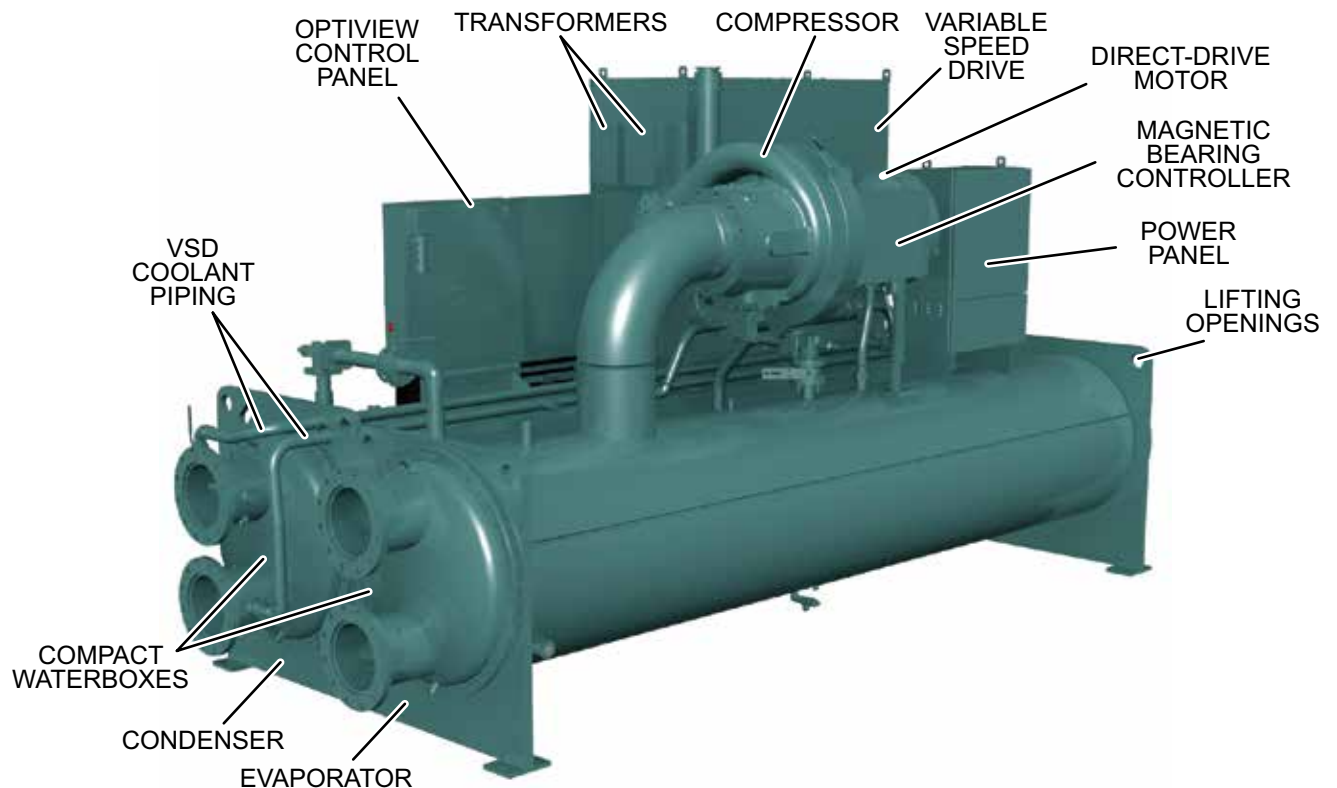

LD14022b

FIGURE 1 - YMC² CHILLER COMPONENTS

INSPECTION – DAMAGE – SHORTAGE

The unit shipment should be checked on arrival to see that all major pieces, boxes and crates are received. Each unit should be checked on the trailer or rail car when received, before unloading, for any visible signs of damage. Any damage or signs of possible damage must be reported to the transportation company immediately for their inspection.

JOHNSON CONTROLS WILL NOT BE RESPONSIBLE FOR ANY DAMAGE IN SHIPMENT OR AT JOB SITE OR LOSS OF PARTS. (Refer to *Shipping Damage Claims Form (Form 50.15-NM)*).

When received at the job site all containers should be opened and contents checked against the packing list. Any material shortage should be reported to Johnson Controls immediately. (Refer to *Shipping Damage Claims Form (Form 50.15-NM)*).

YMC² Chillers are not intended to be stored outdoors, exposed to rain and moisture. The shipping wrap is for shipping, not for extended outdoor storage. The chiller should be tarped during any delays to get indoors and moisture desiccant, available for purchase for inside electrical panels should be used for damp areas.

If the chiller was not shipped complete (as shown in Form 1 or 2) use the *Section 4 - Reassembly* in conjunction with this installation manual.

The services of a Johnson Controls representative will be furnished to check the installation, supervise the initial start-up and operation of all chillers installed within the Continental United States.



The Johnson Controls Warranty may be voided if the following restrictions are not adhered to.

1. No valves or connections should be opened under any circumstances because such action will result in loss of the factory refrigerant (Form 1) or nitrogen charge (Form 2).
2. Do not dismantle or open the chiller for any reason except under the supervision of a Johnson Controls representative.

3. When units are shipped dismantled, notify the nearest Johnson Controls office in ample time for a Johnson Controls representative to supervise rigging the unit to its operating position and the assembly of components.
4. Do not make final power supply connections to the compressor motor drive or control center.
5. Do not charge the unit with refrigerant.
6. Do not attempt to start the system.
7. Do not run hot water (>110°F / 43°C max) or steam through the evaporator or condenser at any time.

CHILLER DATA PLATE

A unit data plate is mounted on the control center assembly of each unit, giving unit model number; design working pressure; water passes; refrigerant charge; serial numbers; and motor power characteristics and connection diagrams.

Additional information may be found on the compressor and motor data plates. This information should be included when contacting the factory on any problem.

YMC² SHIPMENT FORMS

The chiller may be ordered and shipped in any of the following forms:

- Form 1 (shipped complete with refrigerant charge)
- Form 2 (shipped complete with refrigerant charge shipped separately)
- Form 3 (shipped in three assemblies)
- Form 7 (shipped in four assemblies)
- Form 9 (shipped in two assemblies with refrigerant charge shipped separately)
- Form 10 (shipped in two assemblies with refrigerant charge)
- Form 11 (shipped as split shells with refrigerant charge)

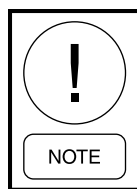

Units that are shipped dismantled MUST be reassembled by, or under the supervision of a Johnson Controls representative.

Refer to Section 4 - Reassembly for detailed reassembly instructions.

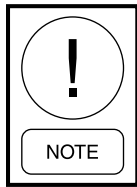

When more than one chiller is involved, the major parts of each unit will be marked to prevent mixing of assemblies. Piping and wiring drawings to be furnished by Johnson Controls.

Form 1

The chiller is shipped complete with miscellaneous loose items shipped together and refrigerant charges are included.

Chiller Unit

The unit is completely assembled at the factory.

- The driveline (compressor/motor assembly) is mounted and all the necessary interconnecting piping is assembled.
- The complete unit is factory leak-tested, evacuated, and shipped charged with R-134A refrigerant.
- The OptiView™ Control Center is mounted on the unit.
- The Variable Speed Drive (VSD) and power panel are mounted, wired, and shipped with glycol.

Miscellaneous Items

The following items are shipped together:

- Four (4) vibration isolation pads (or optional spring isolators and brackets).
- VSD operating coolant (Inhibited water)
- Other shipped loose items, including piping, water temperature controls, wiring, etc.

Form 2

The chiller is shipped complete with refrigerant charges shipped separately and miscellaneous loose items shipped together.

Arrangements with the local service office must be made to ensure refrigerant is on-site when the unit is ready to be charged.

Chiller Unit

The unit is completely assembled at the factory.

- The driveline (compressor/motor assembly) is mounted and all the necessary interconnecting piping is assembled.

- The complete unit is factory leak-tested, evacuated, and shipped charged with a 3 to 7 PSIG (20 to 50 kPa) holding charge of dry nitrogen.
- The OptiView™ Control Center is mounted on the unit.
- The Variable Speed Drive (VSD) and power panel are mounted, wired, and shipped with Glycol.

Miscellaneous Items

The following items are shipped together:

- Four (4) vibration isolation pads (or optional spring isolators and brackets).
- Other shipped loose items, including piping, water temperature controls, wiring, etc.
- VSD operating coolant (Inhibited water)

Form 3

Prior to shipping, the unit is completely assembled at the factory. Interconnecting piping is assembled and the complete unit is wired and leak-tested.

The unit is dismantled and shipped as follows:

1. The driveline (compressor/motor assembly).
2. The evaporator/condenser shell assembly.
3. The Variable Speed Drive (VSD).
4. Miscellaneous shipped loose items.
5. Refrigerant charges shipped separately.

Arrangements with the local service office must be made to ensure refrigerant is on-site when the unit is ready to be charged.

Driveline

The driveline (compressor/motor assembly) is removed from the shells and skidded.

- All integral wiring is left on the compressor.
- All openings on the compressor are closed and shipped charged with a 3 to 7 PSIG (20 to 50 kPa) holding charge of dry nitrogen.

Shells

The evaporator and condenser are assembled prepared for shipping but not skidded.

- All conduit is left on the shells.
- All openings the shells are closed and charged with a 3 to 7 PSIG (20 to 50 kPa) holding charge of dry nitrogen.

Variable Speed Drive (VSD)

The VSD is skidded and shipped separately from the assembled chiller.

- The VSD is filled with glycol for shipping. The VSD operating coolant (Inhibited water) is shipped with the other loose items.

Miscellaneous Material

The following assemblies and items are shipped together:

- OptiView™ Control Center
- Power panel
- Four (4) vibration isolation pads (or optional spring isolators and brackets).
- Other shipped loose items, including piping, water temperature controls, wiring, etc.
- VSD operating coolant (Inhibited water)

Form 7

Prior to shipping, the unit is completely assembled at the factory. Interconnecting piping is assembled and the complete unit is wired and leak-tested.

The unit is dismantled and shipped as follows:

1. The driveline (compressor/motor assembly).
2. The evaporator.
3. The condenser.
4. The Variable Speed Drive (VSD).
5. Refrigerant charges shipped separately.
6. Miscellaneous shipped loose items.

Arrangements with the local service office must be made to ensure refrigerant is on-site when the unit is ready to be charged.

Driveline

The driveline (compressor/motor assembly) is removed from shells and skidded.

- All integral wiring is left on the compressor.
- All wiring harnesses on shells are removed.
- All openings on the compressor are closed and shipped charged with a 3 to 7 PSIG (20 to 50 kPa) holding charge of dry nitrogen.

Shells

The evaporator and condenser are separated at the tube sheets and prepared for shipping separately but not skidded.

- All conduit is left on the shells.
- Refrigerant lines between shells are flanged and capped, requiring no welding.
- All openings the shells are closed and charged with a 3 to 7 PSIG (20 to 50 kPa) holding charge of dry nitrogen.

Variable Speed Drive (VSD)

The VSD is skidded and shipped separately from the assembled chiller.

- The VSD is filled with glycol for shipping. The VSD operating coolant (Inhibited water) is shipped with the other loose items.

Miscellaneous Items

The following assemblies and items are shipped together:

- OptiView™ Control Center
- Power panel
- Four (4) vibration isolation pads (or optional spring isolators and brackets).
- Operating coolant (Inhibited water)
- Other shipped loose items, including piping, water temperature controls, wiring, isolators, etc.

Form 9

Prior to shipping, the unit is completely assembled at the factory. Interconnecting piping is assembled and the complete unit is wired and leak-tested.

The chiller is shipped in two assemblies as follows:

1. The chiller unit (less the VSD).
2. The VSD.
3. Refrigerant charges shipped separately.
4. Miscellaneous shipped loose items.

Arrangements with the local service office must be made to ensure refrigerant is on-site when the unit is ready to be charged.

Chiller Unit

The unit is first completely assembled at the factory:

- The driveline (compressor/motor assembly) is mounted, with all necessary interconnecting piping assembled.
- Interconnecting piping is assembled and the complete unit is factory leak-tested then evacuated and shipped charged with a 3 to 7 PSIG (20 to 50 kPa) holding charge of dry nitrogen.
- The Motor Terminal Box adapter remains attached to the chiller unit.

Variable Speed Drive (VSD)

The VSD is skidded and shipped separately from the assembled chiller.

- The VSD is filled with glycol for shipping. The VSD operating coolant (Inhibited water) shipped with the other loose items.

Miscellaneous Material

The following assemblies and items are shipped together:

- Four (4) vibration isolation pads (or optional spring isolators and brackets).
- Other shipped loose items, including piping, water temperature controls, wiring, etc.
- VSD operating coolant (Inhibited water)

Form 10

Prior to shipping, the unit is completely assembled at the factory. Interconnecting piping is assembled and the complete unit is wired and leak-tested.

The chiller is shipped in two assemblies:

1. The assembled chiller unit.
2. The VSD.
3. Refrigerant charges are included.
4. Miscellaneous shipped loose items.

Chiller Unit

The unit is first completely assembled at the factory:

- The driveline (compressor/motor assembly) is mounted, with all necessary interconnecting piping assembled.
- The complete unit is factory leak-tested, evacuated, and shipped charged with R-134A refrigerant.
- The Motor Terminal Box adapter remains attached to the chiller unit.

Variable Speed Drive (VSD)

The VSD is skidded and shipped separately from the assembled chiller.

- The VSD is filled with glycol for shipping. The VSD operating coolant (Inhibited water) shipped with the other loose items.

Miscellaneous Material

The following assemblies and items are shipped together:

- Four (4) vibration isolation pads (or optional spring isolators and brackets).
- Other shipped loose items, including piping, water temperature controls, wiring, etc.
- VSD operating coolant (Inhibited water)

Form 11

Prior to shipping, the unit is completely assembled at the factory. Interconnecting piping is assembled and the complete unit is wired and leak-tested.

The chiller is split down the middle and shipped in two assemblies:

1. The condenser-side assembly.
2. The evaporator-side assembly.
3. Refrigerant charges are included.
4. Miscellaneous shipped loose items.

Arrangements with the local service office must be made to ensure refrigerant is on-site when the unit is ready to be charged.

Condenser-Side Assembly (Condenser / Optiview™ Control Center / Variable Speed Drive)

The Condenser-side assembly consists of the Condenser, the OptiView™ Control Center and the Variable Speed Drive.

- All conduit is left on the condenser shell.
- Interconnecting piping between shells are flanged and capped, requiring no welding.
- All openings on the condenser shell are closed and shipped charged with a 3 to 7 PSIG (20 to 50 kPa) holding charge of dry nitrogen.

Evaporator-Side Assembly (Evaporator / Driveline / Power Panel)

The evaporator-side assembly consists of the evaporator, the driveline (compressor/motor assembly), and the Power panel.

- All conduit is left on the evaporator shell.
- Interconnecting piping between shells are flanged and capped, requiring no welding.
- All integral wiring is left on the compressor.
- All openings on the evaporator shell and driveline are closed and shipped charged with a 3 to 5 PSIG (20 to 50 kPa) holding charge of dry nitrogen.

Miscellaneous Material

The following items are shipped together:

- Four (4) vibration isolation pads (or optional spring isolators and brackets)
- Other shipped loose items, including piping, water temperature controls, wiring, etc.
- VSD operating coolant (Inhibited water)

SECTION 2 - RIGGING AND LIFTING



Improper use of rigging equipment can result in serious injury. Do not operate without proper training and authorization.

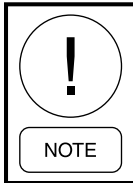

It is the responsibility of the installer to have a qualified and certified crane operator and rigger for lifting components and relocating to the new site.

To perform a safe and effective rigging practice the installer is responsible for inspection and operation of the lifting equipment, special site considerations, proper rigging and lifting practices, and any safety considerations.

Particular items the installer must be aware of are:

- Rope with no visible wear, twisted, kinked, or damaged chains.
- Deformed, cracked, or stretched hooks or safety latch on the hook is not damaged.
- Correct drum spooling as the hook is raised.
- Do not operate a damaged or malfunctioning hoist.
- Do not wrap the hoisting rope or chain around the load.
- Do not lift loads over people.

FORM 1 TOTAL WEIGHT

The heaviest possible YMC² combination of total weight for Form 1 shipment is 33,863 lbs (15,360 kg) or 17 ton. See Weights on page 67 for YMC² weight breakdown.

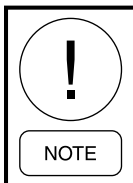

The actual unit total shipping and operating weight is on the submittal drawings.

FORM 1 SHIPMENT

The chiller is shipped complete with miscellaneous items shipped together with refrigerant charges are included.

- The unit is completely assembled at the factory.
- The driveline (compressor/motor assembly) is mounted and all the necessary interconnecting piping is assembled.
- The complete unit is factory leak-tested, evacuated and shipped charged with R-134A refrigerant.
- The OptiView™ Control Center is mounted on the unit.
- The Power Panel is mounted on the unit.
- The Variable Speed Drive (VSD) is mounted, wired, and ship with glycol.

Unit Rigging

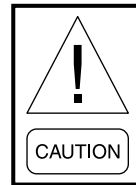

One lifting chain is required for each lifting point and each chain having a working load limit 30% of unit total weight.

The lifting chains traversing the evaporator/condenser shells should remain 90° +/- 10° from horizontal. A spreader bar may be required to achieve the +/- 10°.

1. Attach rigging chains to an adequate lifting device.
2. Attach chains to the lifting holes at the corner of each end sheet as shown on *Figure 2 on page 16*.
3. If necessary to avoid contact with chiller components install side spreader bars between the Evaporator and Condenser end sheet lifting chains.
4. The angle of the lifting chains traversing the end sheet should not be less than 65° as shown on *Figure 2 on page 16*.
5. With an adequate lifting device lift the unit slightly off the ground to determine adjustments necessary to keep the unit level. Make adjustments as necessary to level the unit.

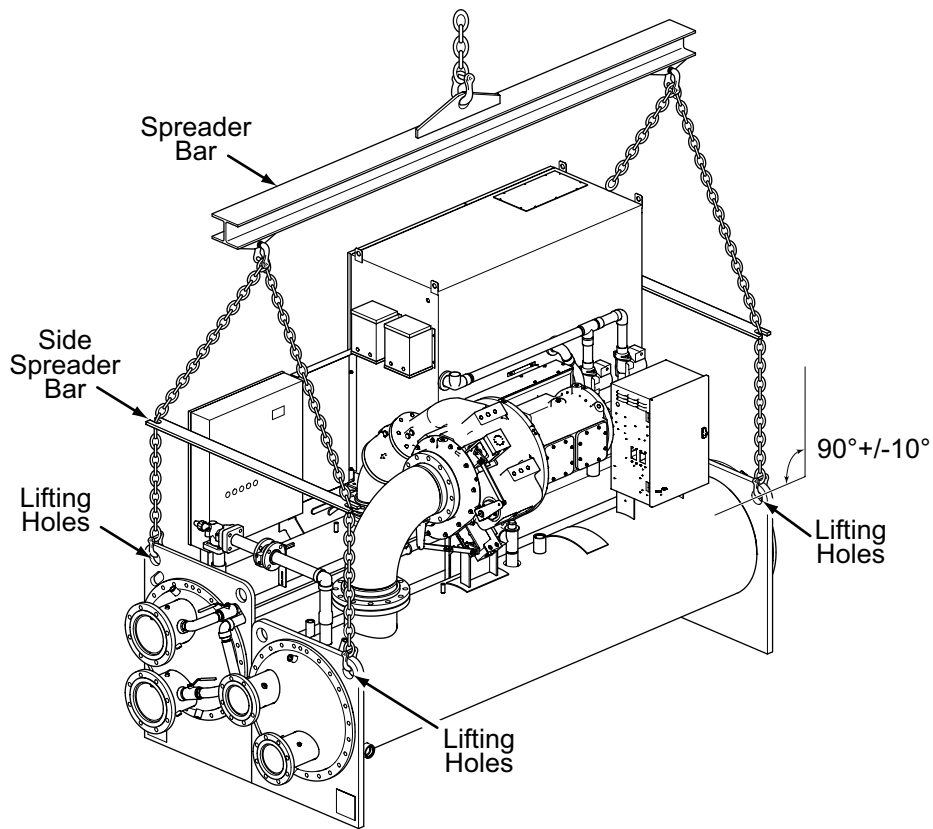

LD16719

FIGURE 2 - FORM 1 AND 2 RIGGING WITH SIDE SPREADER BAR

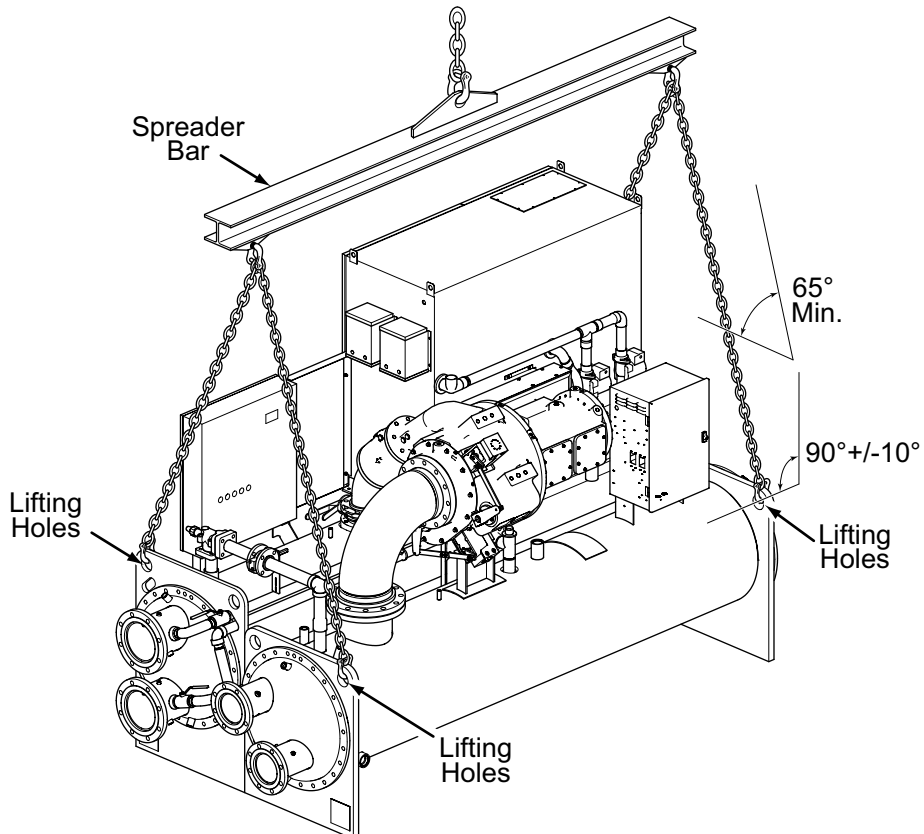

LD16719a

FIGURE 3 - FORM 1 AND 2 RIGGING WITHOUT SIDE SPREADER BAR

FORM 2 TOTAL WEIGHT

The heaviest possible YMC² combination of total weight for Form 2 shipment is 21,900 lbs (10,000 kg) or 11 ton. See Weights *on page 67* for YMC² weight breakdown.

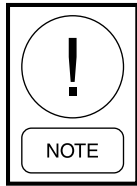

The actual unit total shipping and operating weight is on the submittal drawings.

FORM 2 SHIPMENT

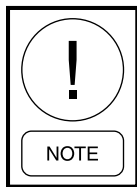

Arrangements with the local service office must be made to ensure refrigerant is on-site when unit is ready to be charged.

The chiller is shipped complete with miscellaneous items shipped together.

- The driveline (compressor/motor assembly) is mounted and all the necessary interconnecting piping is assembled.
- The complete unit is factory leak-tested, evacuated and shipped charged with a 3 to 7 PSIG (20 to 50 kPa) holding charge of dry nitrogen.
- The OptiView™ Control Center is mounted.
- The Power Panel is mounted on the unit.
- The Variable Speed Drive (VSD) is mounted, wired and shipped with Glycol.
- Refrigerant charges are shipped separately.

Unit Rigging

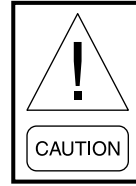

One lifting chain is required for each lifting point and each chain having a working load limit 30% of unit total weight.

The lifting chains traversing the evaporator/condenser shells should remain 90° +/- 10° from horizontal. A spreader bar may be required to achieve the +/- 10°.

1. Attach rigging chains to an adequate lifting device.
2. Attach chains to the lifting holes at the corner of each end sheet as shown on *Figure 2 on page 16*.
3. If necessary to avoid contact with chiller components install side spreader bars between the Evaporator and Condenser end sheet lifting chains.
4. The angle of the lifting chains traversing the end sheet should not be less than 65° as shown on *Figure 2 on page 16*.
5. With an adequate lifting device lift the unit slightly off the ground to determine adjustments necessary to keep the unit level. Make adjustments as necessary to level the unit.

FORM 3 SHIPMENT

The chiller is shipped in five major assemblies:

- The evaporator/condenser shell assembly.
- The driveline (compressor/motor assembly).
- The Variable Speed Drive (VSD).
- The OptiView™ Control Center assembly.
- The Power Panel assembly.
- Miscellaneous shipped loose items.



One lifting chain is required for each lifting point and each chain having a working load limit 40% of condenser and evaporator weight or heat exchanger being lifted.

The lifting chains traversing the evaporator/condenser shells should remain 90° +/- 10° from horizontal. A spreader bar may be required to achieve the +/- 10°.

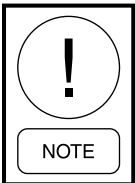

Refrigerant charges are shipped separately. Arrangements with the local service office must be made to ensure refrigerant is on-site when the unit is ready to be charged.

When optional skids are used it may be necessary to remove the skids so riggers skates can be used under the unit end sheets to reduce overall height.

Shells

1. Attach rigging chains to an adequate lifting device.
2. Attach chains to the lifting holes at the corner of each end sheet as shown on *Figure 5 on page 19*.
3. If necessary to avoid contact with chiller components install side spreader bars between the Evaporator and Condenser end sheet lifting chains.
4. The angle of the lifting chains traversing the end sheet should not be less than 65° as shown on *Figure 5 on page 19*.
5. With an adequate lifting device lift the unit slightly off the ground to determine adjustments necessary to keep the unit level. Make adjustments as necessary to level the unit.

Compressor Motor Assembly**TABLE 1 - COMPRESSOR MOTOR WEIGHTS**

Compr Code	Pounds	Kilograms
M2C-197FAC	2,861	1298
M2C-205FAC	2,867	1300
M2C-218FAC	2,987	1355
M2C-233FAC	2,999	1,360
M2C-246FAC	2,989	1,356
M6C-331FAC	4,500	2,041

1. Attach rigging chains to each end of the compressor/motor assembly as shown in *Figure 4 on page 18*.
2. Lift the compressor/motor assembly off the ground to check for center of gravity. Make adjustments as necessary.

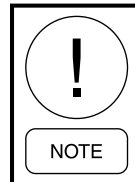

The M2C and M6C Compressor/Motor has metric lifting lugs

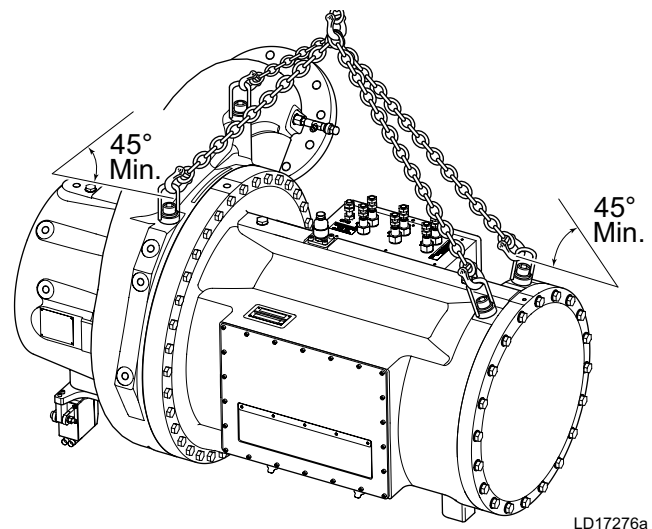

Use lifting chains with working load limit each 70% of total driveline weight.

**FIGURE 4 - DRIVELINE RIGGING**

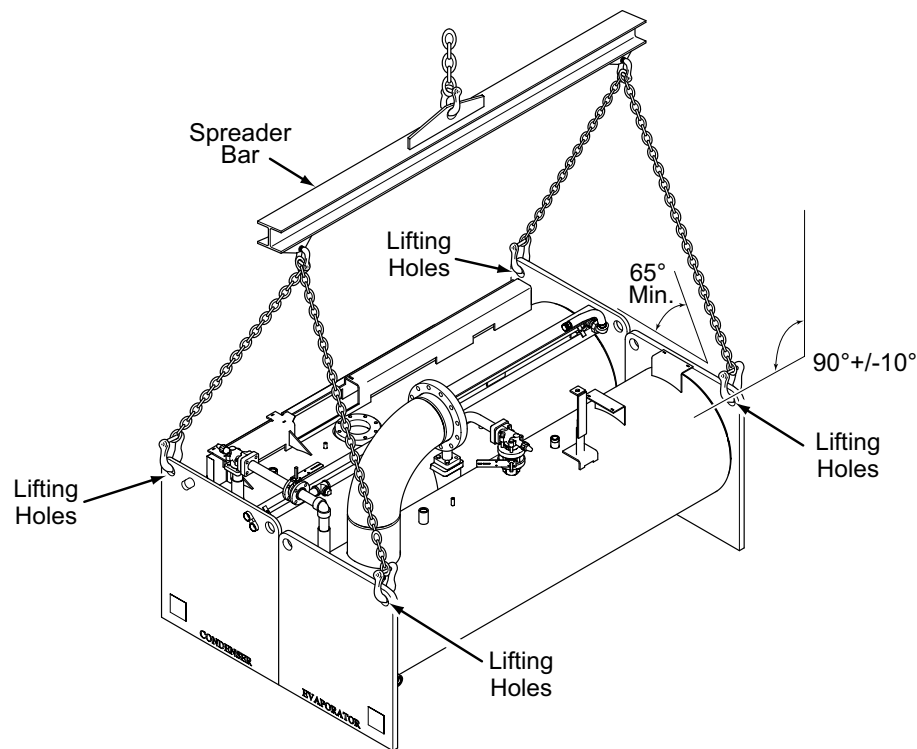

LD16732

FIGURE 5 - FORM 3 RIGGING WITHOUT SIDE SPREADER BARS

Variable Speed Drive (VSD)

TABLE 2 - VARIABLE SPEED DRIVE WEIGHTS

Model	Pounds	Kilograms
HYP490XH	1,226	556
HYP774XH	2,060	934



The VSD is shipped with glycol in the cooling system. The VSD coolant must be changed to the inhibitor provided with the shipped loose items prior to starting the unit.

1. Attach rigging chains from an adequate lifting device to the four lifting holes at the top of the VSD as shown in Figure 6 on page 19, for VSD weight refer to Table 2 on page 19.
2. Lift the VSD slightly off the ground to check for center of gravity. Make adjustments as necessary to level the VSD.
3. Lift the VSD and remove all packing material.
4. Carefully lower the VSD on to the supports on the condenser.
5. Fasten the VSD to the condenser and to the motor terminal box duct. Remove the rigging chains.

6. Make all necessary connections for the VSD cooling loop to be complete.



Use lifting chains with working load limit each 35% of total VSD weight.

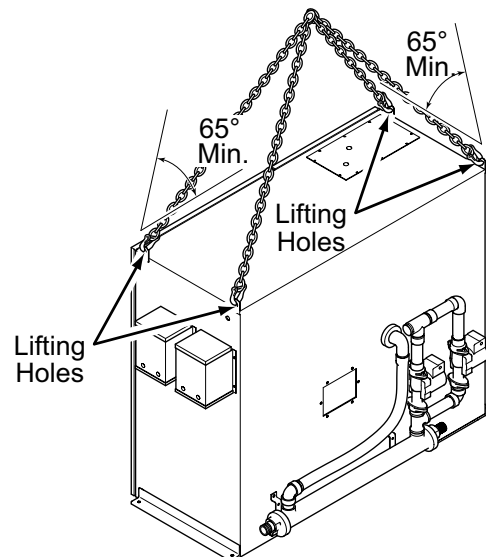

LD16730

FIGURE 6 - VARIABLE SPEED DRIVE RIGGING

Power Panel

TABLE 3 - POWER PANEL

Description	Pounds	Kilograms
Power Panel	300	135

1. Attach rigging chains to an adequate lifting device.
2. Attach the chains to the lifting holes at the top of the Power Panel as shown in Figure 7 on page 20.
3. Lift the Power Panel slightly off the ground to check for center of gravity. Make adjustments as necessary to level the Power Panel.
4. Lift the Power Panel and remove all packing material.
5. Carefully lower the Power Panel on to the supports on the evaporator.
6. Attach the Power Panel to the evaporator with the proper hardware. Remove the rigging chains.
7. Re-connect all unit wiring and harnesses (refer to YMC² Unit Wiring and Field Control Modifications (Form 160.78-PW2).



Use lifting chains with working load limit each 70 of the power panel weight.

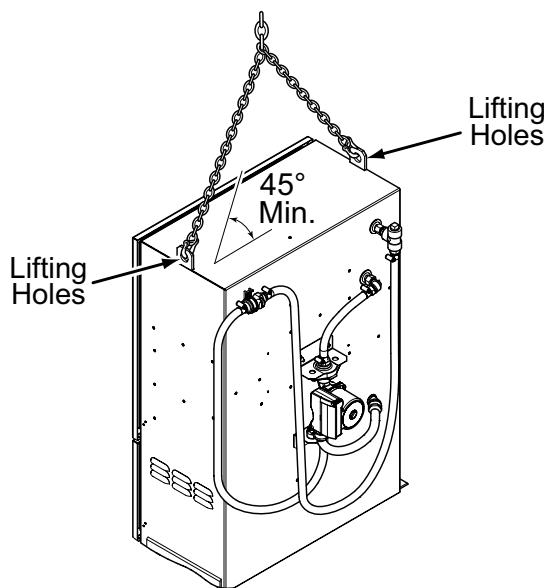

LD17275

FIGURE 7 - POWER PANEL

OptiView™ Control Center



The OptiView™ Control Center weighs over 50 pounds and a technician and helper are needed for the installation of the panel.

TABLE 4 - CONTROL PANEL WEIGHTS

Description	Pounds	Kilograms
OptiView	75	34

1. Lift the OptiView™ Control Center and remove all packing material.
2. Carefully lower the OptiView™ Control Center on to the supports on the condenser.
3. Attach the OptiView™ Control Center to the condenser with the proper hardware.
4. Connect all unit wiring and harnesses (refer to YMC² Unit Wiring and Field Control Modifications (Form 160.78-PW2).

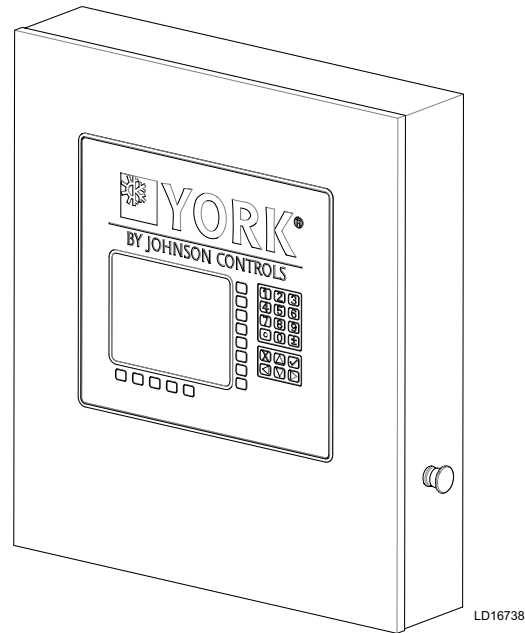
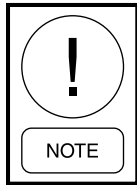

FIGURE 8 - OPTIVIEW CONTROL CENTER

FORM 7 SHIPMENT

The chiller is shipped in six assemblies:

- The driveline (compressor/motor assembly).
- The evaporator.
- The condenser.
- The Variable Speed Drive (VSD).
- The OptiView™ Control Center assembly.
- The Power Panel assembly.
- Miscellaneous shipped loose items.



Refrigerant charges are shipped separately. Arrangements with the local service office must be made to ensure refrigerant is on-site when the unit is ready to be charged.

When optional skids are used it may be necessary to remove the skids so riggers skates can be used under the unit end sheets to reduce overall height.

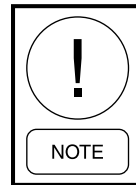

The lifting chains along the axis of the evaporator/condenser shells should not exceed 90° +/- 10°. A spreader bar may be required to achieve the +/- 10°.

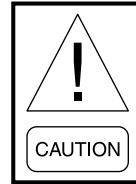

One chain is required per each lifting point.

Use lifting chains with working load limit each at least 40% of the total shell weight.

Condenser

1. Attach rigging chains to an adequate lifting device.
2. Attach chains to the two lifting holes at the corner of each end sheet as shown in *Figure 9* on page 21.

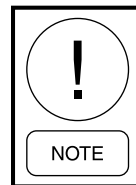

Angles apply to condenser or evaporator.

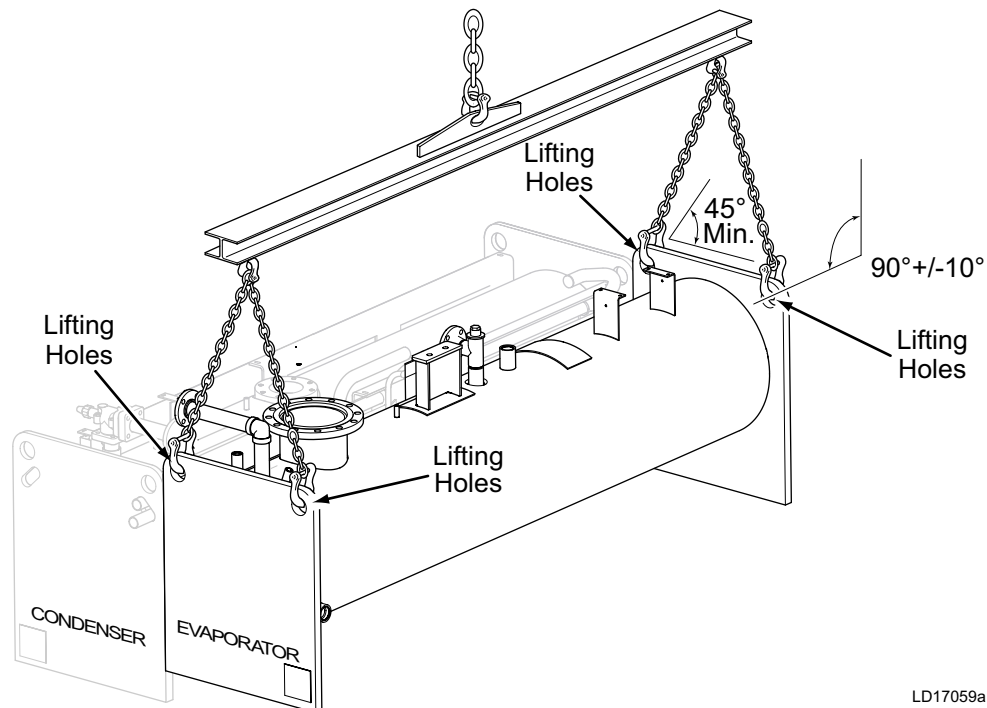

LD17059a

FIGURE 9 - FORM 7 RIGGING WITH SIDE SPREADER BARS

- If necessary to maintain minimum angles install spreader bars between the condenser lifting chains to have the chains as shown in *Figure 9 on page 21*.



The angle of the lifting chains is critical and damage to the unit may occur if the rigging is not completed as described.

- With an adequate lifting device lift the unit slightly off the ground to check for center of gravity. Make adjustments as necessary to level the unit.

Evaporator

- Attach rigging chains to an adequate lifting device.
- Attach chains to the two lifting holes at the corner of the end sheet as shown in *Figure 9 on page 21*.
- If necessary to maintain minimum angles, install spreader bars between the Evaporator end sheets to have the chains as shown in *Figure 9 on page 21*.



The angle of the lifting chains is critical and damage to the unit may occur if the rigging is not completed as described.

- With an adequate lifting device lift the unit slightly off the ground to check for center of gravity. Make adjustments as necessary to level the unit.

Compressor Motor Assembly

TABLE 5 - COMPRESSOR MOTOR WEIGHTS

Compr Code	Pounds	Kilograms
M2C-197FAC	2,861	1298
M2C-205FAC	2,867	1300
M2C-218FAC	2,987	1355
M2C-233FAC	2,999	1,360
M2C-246FAC	2,989	1,356
M6C-331FAC	4,500	2,041

- Attach rigging chains to each end of the compressor/motor assembly as shown in *Figure 10 on page 22*.
- Lift the compressor/motor assembly off the ground to check for center of gravity. Make adjustments as necessary.

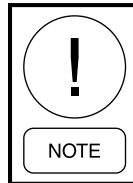

The M2C and M6C Compressor/Motor has metric lifting lugs



Use lifting chains with working load limit each 70% of total driveline weight.

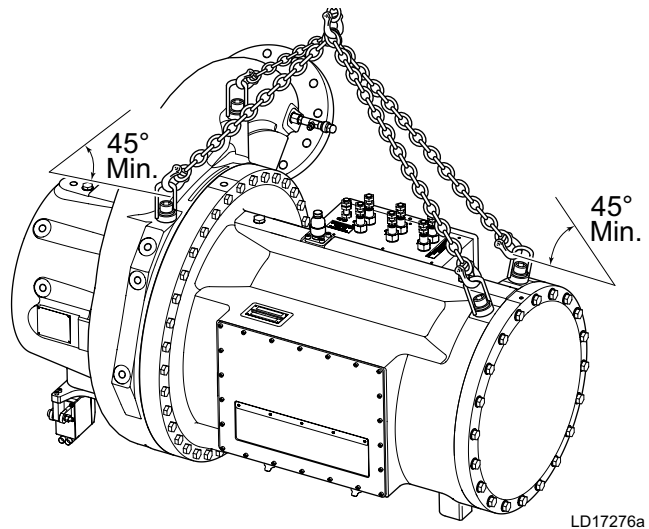

FIGURE 10 - DRIVELINE RIGGING

Variable Speed Drive (VSD)

TABLE 6 - VARIABLE SPEED DRIVE WEIGHTS

Model	Pounds	Kilograms
HYP490XH	1,226	556
HYP774XH	1,226	934



The VSD is shipped with glycol in the cooling system. The VSD coolant must be changed to the inhibitor provided with the shipped loose items prior to starting the unit.

1. Attach rigging chains from an adequate lifting device to the four lifting holes at the top of the VSD as shown in *Figure 11 on page 23*.
2. Lift the VSD slightly off the ground to check for center of gravity. Make adjustments as necessary to level the VSD.
3. Lift the VSD and remove all packing material, for VSD weight refer to *Table 6 on page 22*.

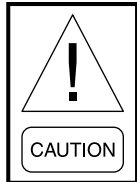

Use lifting chains with working load limit each 35% of total VSD weight.

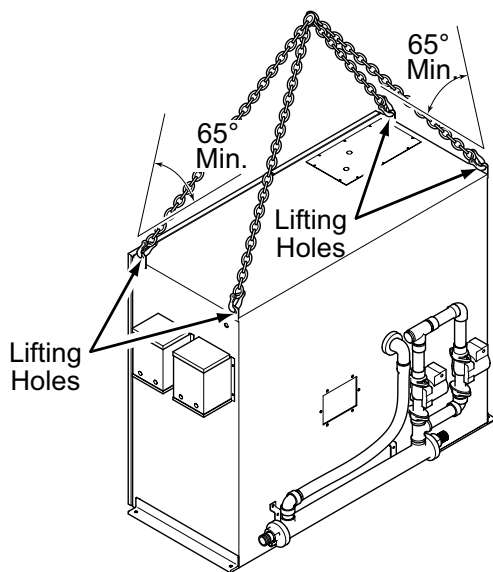

LD16730

FIGURE 11 - VARIABLE SPEED DRIVE RIGGING

Power Panel

TABLE 7 - POWER PANEL

Description	Pounds	Kilograms
Power Panel	300	135

1. Attach rigging chains to an adequate lifting device.
2. Attach the chains to the lifting holes at the top of the Power Panel as shown in *Figure 12 on page 23*.
3. Lift the Power Panel slightly off the ground to check for center of gravity. Make adjustments as necessary to level the Power Panel.
4. Lift the Power Panel and remove all packing material.



Use lifting chains with working load limit each 70% of the Power Panel weight.

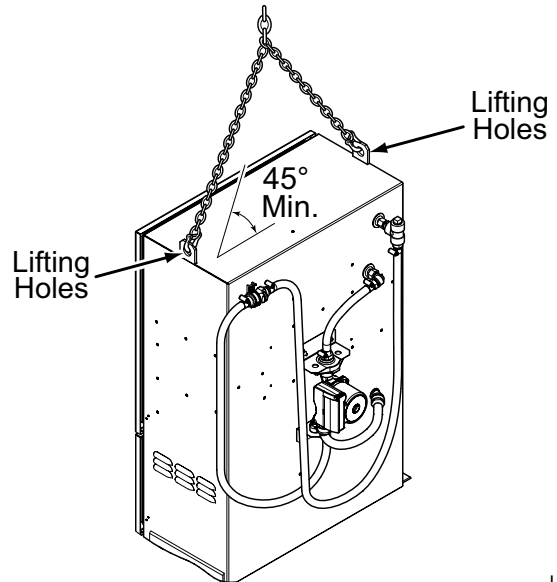

LD17275

FIGURE 12 - POWER PANEL

OptiView™ Control Center



The OptiView™ Control Center weighs over 50 pounds and a technician and helper are needed for the installation of the panel.

TABLE 8 - CONTROL PANEL WEIGHTS

Description	Pounds	Kilograms
OptiView	75	34

1. Lift the OptiView™ Control Center and remove all packing material.
2. Carefully lower the OptiView™ Control Center on to the supports on the condenser.
3. Attach the OptiView™ Control Center to the condenser with the proper hardware.

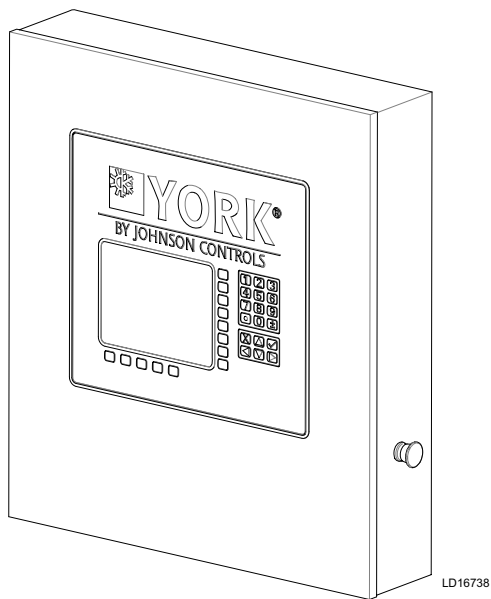

FIGURE 13 - OPTIVIEW CONTROL CENTER

FORM 9 SHIPMENT

The chiller is shipped in two assemblies:

- The chiller unit (less the VSD).
- The VSD.
- Miscellaneous shipped loose items.

The unit is first factory assembled, refrigerant piped, wired and leak tested; then dismantled for shipment.

All wiring integral with compressor is left on it, and all conduit is left on shell. All openings on compressor and shell are closed and charged with dry nitrogen (3 to 7 PSIG (20 to 50 kPa).

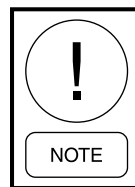

Refrigerant charges are shipped separately. Arrangements with the local service office must be made to ensure refrigerant is on-site when unit is ready to be charged.

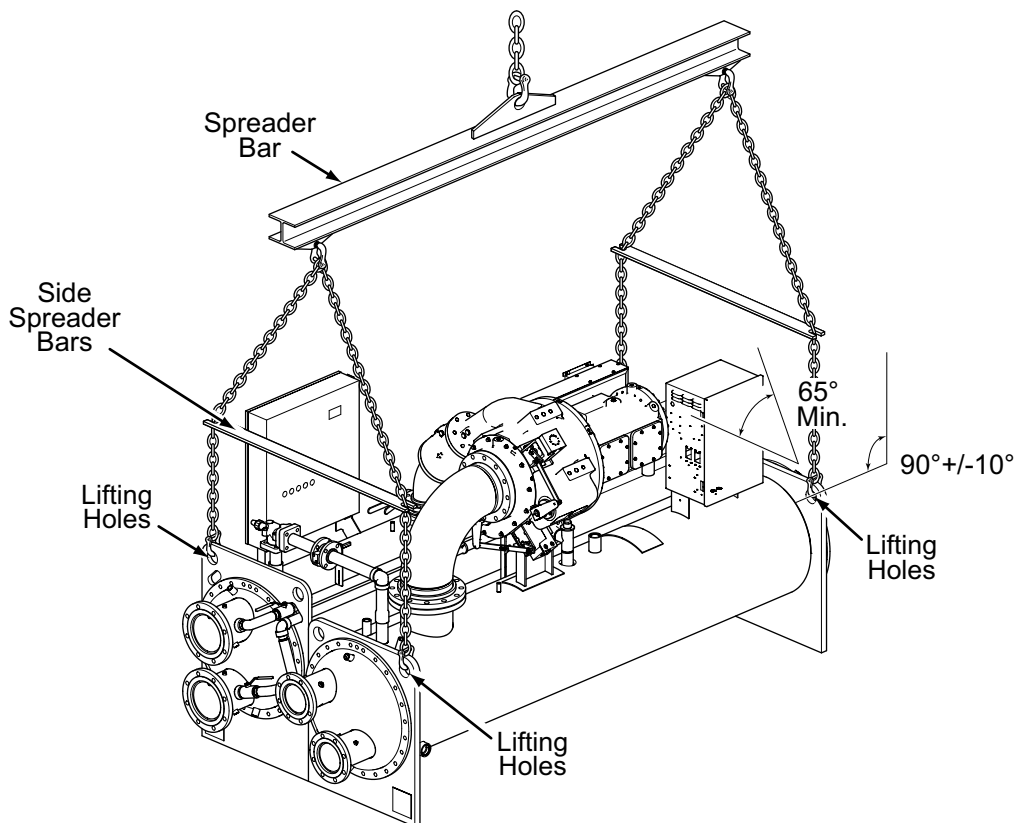
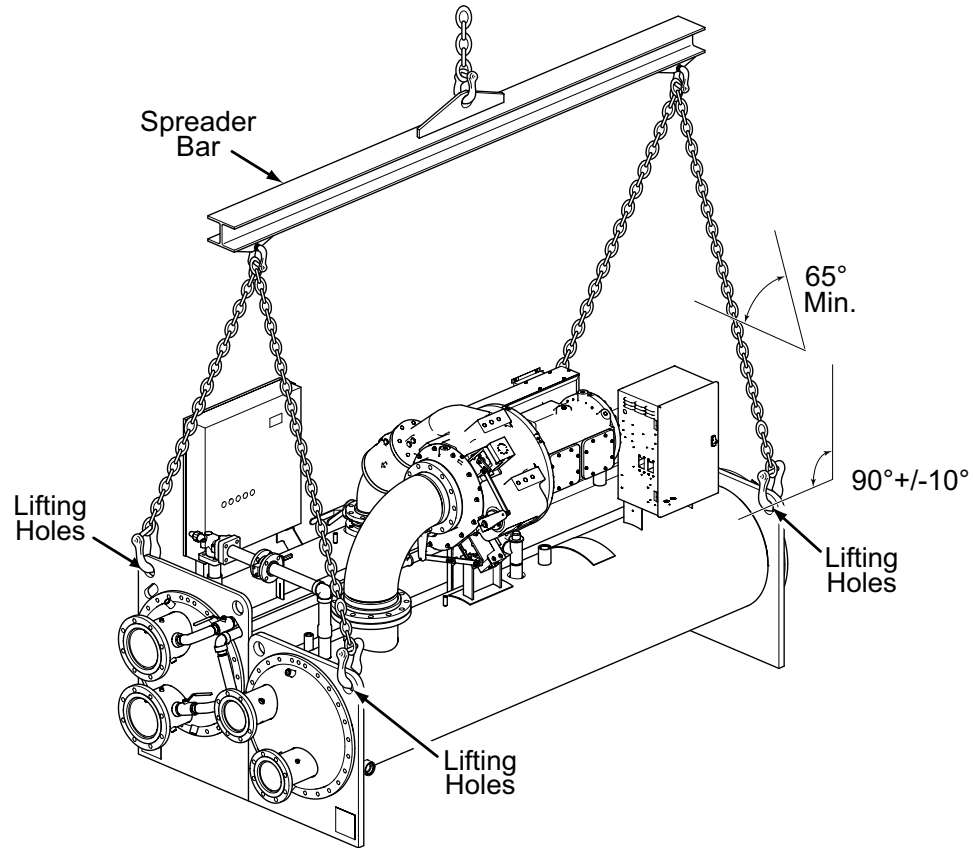

FIGURE 14 - FORM 9 AND 10 RIGGING WITH SIDE SPREADER BARS



LD16739a

FIGURE 15 - FORM 9 AND 10 RIGGING WITHOUT SIDE SPREADER BARS

Unit Rigging

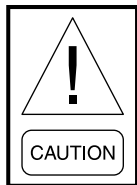

One lifting chain is required for each lifting point and each chain having a working load limit 40% of unit total weight.

The lifting chains traversing the evaporator/condenser shells should remain 90° +/- 10° from horizontal. A spreader bar may be required to achieve the +/- 10°.

1. Attach rigging chains to an adequate lifting device.
2. Attach chains to the lifting holes at the corner of each end sheet as shown on *Figure 15* on page 25.
3. If necessary to avoid contact with chiller components install side spreader bars between the Evaporator and Condenser end sheet lifting chains.
4. The angle of the lifting chains traversing the end sheet should not be less than 65° as shown on *Figure 15* on page 25.

5. With an adequate lifting device lift the unit slightly off the ground to determine adjustments necessary to keep the unit level. Make adjustments as necessary to level the unit.

Variable Speed Drive (VSD)

TABLE 9 - VARIABLE SPEED DRIVE WEIGHTS

Model	Pounds	Kilograms
HYP490XH	1,226	556
HYP774XH	1,226	934

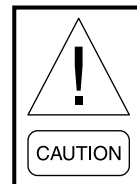

The VSD is shipped with glycol in the cooling system. The VSD coolant must be changed to the inhibitor provided with the shipped loose items prior to starting the unit.

1. Attach rigging chains from an adequate lifting device to the four lifting holes at the top of the VSD as shown in *Figure 16* on page 26.
2. Lift the VSD slightly off the ground to check for center of gravity. Make adjustments as necessary to level the VSD.

- Lift the VSD and remove all packing material, for VSD weight refer to *Table 10 on page 26*.
- Carefully lower the VSD on to the supports on the condenser.
- Fasten the VSD to the condenser and to the motor terminal box duct. Remove the rigging chains.



Use lifting chains with working load limit each 35% of total VSD weight.

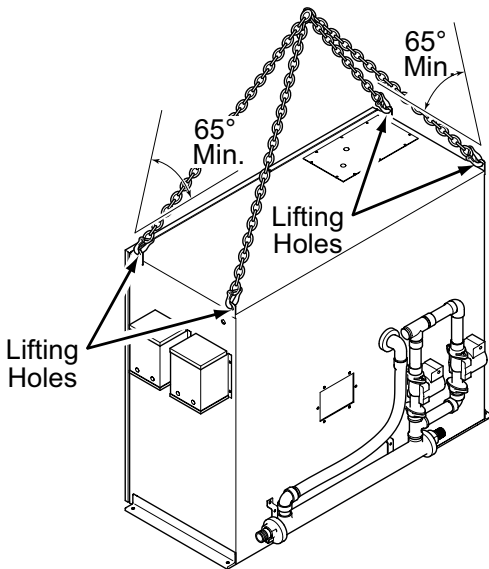

LD16730

FIGURE 16 - VARIABLE SPEED DRIVE RIGGING

FORM 10 SHIPMENT

The chiller is shipped in two assemblies:

- The chiller unit (less the VSD).
- The VSD.
- Miscellaneous shipped loose items.

The complete unit is factory leak-tested, evacuated, and shipped charged with R-134A refrigerant.

The unit is first factory assembled, refrigerant piped, wired and leak tested; then dismantled for shipment. Evaporator/condenser is not skidded. All wiring integral with compressor is left on it, and all conduit is left on shell.

Unit Rigging

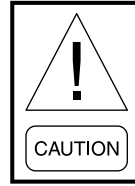

One lifting chain is required for each lifting point and each chain having a working load limit 30% of unit total weight or heat exchanger being lifted.

The lifting chains traversing the evaporator/condenser shells should remain 90° +/- 10° from horizontal. A spreader bar may be required to achieve the +/- 10°.

- Attach rigging chains to an adequate lifting device.
- Attach chains to the lifting holes at the corner of each end sheet as shown on *Figure 14 on page 24*.
- If necessary to avoid contact with chiller components install side spreader bars between the Evaporator and Condenser end sheet lifting chains.
- The angle of the lifting chains traversing the end sheet should not be less than 65° as shown on *Figure 14 on page 24*.
- With an adequate lifting device lift the unit slightly off the ground to determine adjustments necessary to keep the unit level. Make adjustments as necessary to level the unit.

Variable Speed Drive (VSD)

TABLE 10 - VARIABLE SPEED DRIVE WEIGHTS

Model	Pounds	Kilograms
HYP490XH	1,226	556
HYP774XH	1,226	934



The VSD is shipped with glycol in the cooling system. The VSD coolant must be changed to the inhibitor provided with the shipped loose items prior to starting the unit.

- Attach rigging chains from an adequate lifting device to the four lifting holes at the top of the VSD as shown in *Figure 17 on page 27*.
- Lift the VSD slightly off the ground to check for center of gravity. Make adjustments as necessary to level the VSD.
- Lift the VSD and remove all packing material, for VSD weight refer to *Table 10 on page 26*.

4. Carefully lower the VSD on to the supports on the condenser.
5. Fasten the VSD to the condenser and to the motor terminal box duct. Remove the rigging chains.



Use lifting chains with working load limit each 35% of total VSD weight.

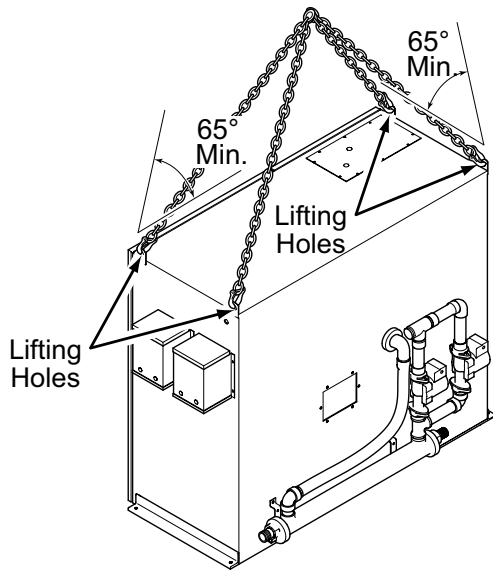

LD16730

FIGURE 17 - VARIABLE SPEED DRIVE RIGGING

FORM 11 SHIPMENT

The chiller is split down the middle and shipped in three assemblies:

- The condenser-side assembly.
- The evaporator-side assembly.
- The OptiView™ Control Center assembly.
- Miscellaneous shipped loose items.

The unit is first factory assembled, refrigerant piped, wired and leak tested; then dismantled for shipment. All wiring integral with compressor is left on it, and all conduit is left on shell.

All openings on compressor and shell are closed and 3 to 7 PSIG (20 to 50 kPa) holding charge of dry nitrogen.

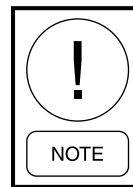

Refrigerant charges are shipped separately. Arrangements with the local service office must be made to ensure refrigerant is on-site when unit is ready to be charged.

Condenser Assembly

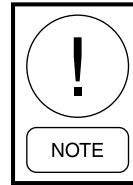

The lifting chains along the axis of the condenser shell should not exceed 90° +/- 10°. A spreader bar may be required to achieve the +/- 10°.



One chain is required per each lifting point.

Use lifting chains with working load limit each at least 40% of the total shell installed component weight.

1. Attach rigging chains to an adequate lifting device.
2. Attach chains to the lifting holes at the corner of the end sheets as shown in *Figure 18 on page 28*.
3. If necessary to maintain minimum angles install side spreader between the condenser end sheets to have the chains as shown in *Figure 18 on page 28*.



The angle of the lifting chains is critical and damage to the unit may occur if the rigging is not completed as described.

4. With an adequate lifting device lift the unit slightly off the ground to check for center of gravity. Make adjustments as necessary to level the unit.

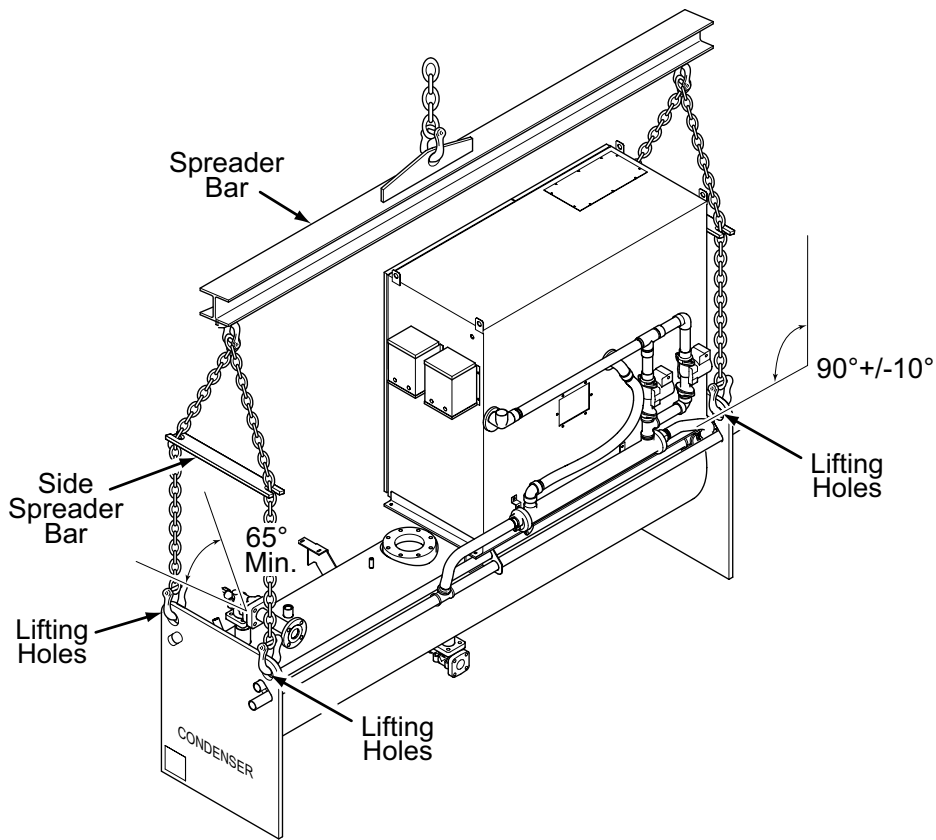

LD17057

FIGURE 18 - FORM 11 CONDENSER ASSEMBLY RIGGING WITH SIDE SPREADER BARS

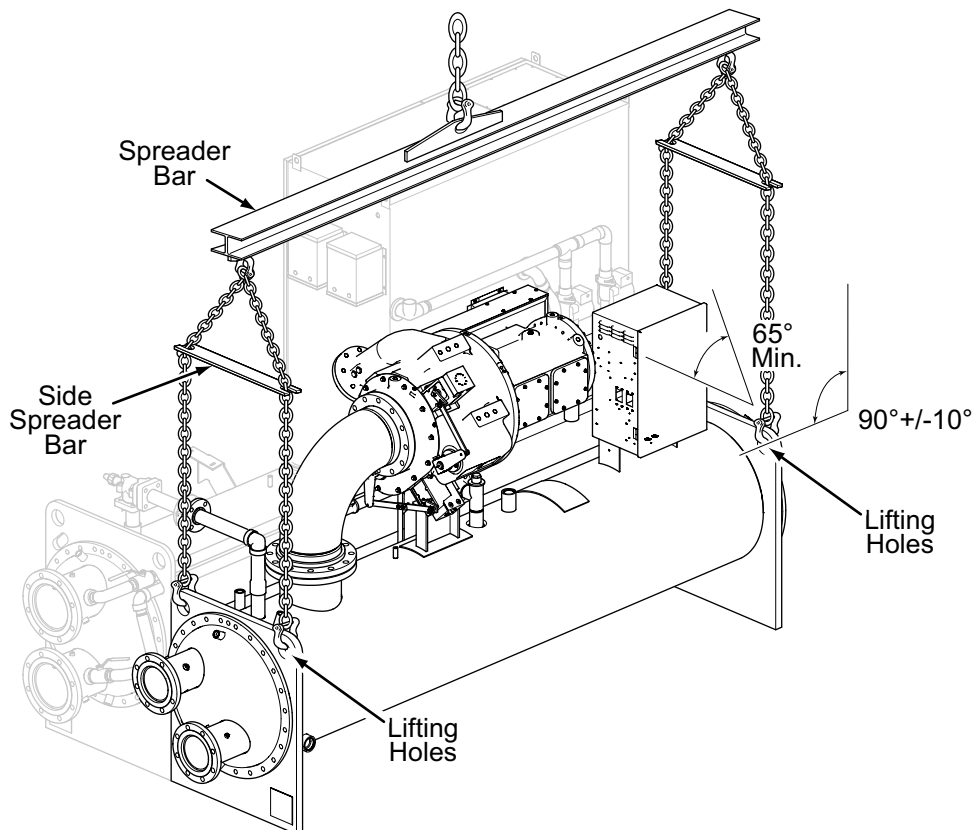

LD17058

FIGURE 19 - FORM 11 EVAPORATOR ASSEMBLY RIGGING WITH SIDE SPREADER BARS

Evaporator Assembly

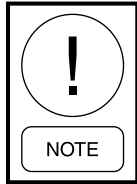

The lifting chains along the axis of the evaporator shell should not exceed 90° +/- 10°. A spreader bar may be required to achieve the +/- 10°.

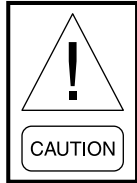

One chain is required per each lifting point.

Use lifting chains with working load limit each at least 40% of the total shell and installed component weight.

1. Attach rigging chains to an adequate lifting device.
2. Attach chains to the lifting holes at the corner of the end sheets as shown in *Figure 19 on page 28*.
3. If necessary to maintain minimum angles install side spreader bars between the evaporator end sheets to have the chains at 90° as shown in *Figure 19 on page 28*.



The angle of the lifting chains is critical and damage to the unit may occur if the rigging is not completed as described.

4. With an adequate lifting device lift the unit slightly off the ground to check for center of gravity. Make adjustments as necessary to level the unit.

OptiView™ Control Center



The OptiView™ Control Center weighs over 50 pounds and a technician and helper are needed for the installation of the panel.

TABLE 11 - CONTROL PANEL WEIGHTS

Description	Pounds	Kilograms
OptiView	75	34

1. Lift the OptiView™ Control Center and remove all packing material.
2. Carefully lower the OptiView™ Control Center on to the supports on the condenser.
3. Attach the OptiView™ Control Center to the condenser with the proper hardware.
4. Connect all unit wiring and harnesses (refer to YMC² Unit Wiring and Field Control Modifications (Form 160.78-PW2)).

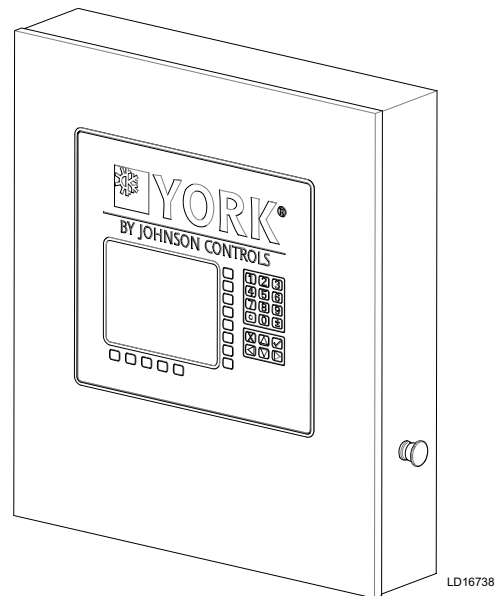

FIGURE 20 - OPTIVIEW CONTROL CENTER

THIS PAGE INTENTIONALLY LEFT BLANK.

SECTION 3 - INSTALLATION

OVERVIEW

The installation process consists of the following steps:

1. Determine Location
 - Foundation Requirements
 - Clearance Requirements
2. Rig Chiller to Final Location
3. Install Isolators
 - Locate and place Isolator Pads, or
 - Install optional Spring Isolators
4. Level Chiller
5. Make Connections
 - Piping
 - Wiring
6. Apply Insulation

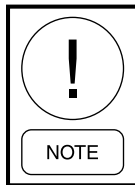

The rigging, operating weights, and overall dimensions are provided in Section 5 - Dimensions, Nozzle Arrangements And Weights to help you determine the clearances required for rigging. Add 6" (15 cm) to overall height for optional skidded unit.

DETERMINE LOCATION



Sufficient clearance to facilitate normal service and maintenance work must be provided around and above the unit and particularly space provided at either end to permit cleaning or replacement of evaporator and condenser tubes – see Clearance. A doorway or other sufficiently large opening properly located may be used.

The chiller should be located in an indoor location where temperatures range from 40°F to 110°F (4.4°C to 43.3°C).

Foundation Requirements

A level floor, mounting pad or foundation must be provided by others, capable of supporting the operating weight of the unit.

Clearance Requirements

Clearances should be adhered to as follows:

Rear and Above Unit	2 ft (61 cm)
Front of Unit	3 ft (91 cm)
Tube Removal	14 ft* (4.3 m) either end

* 10' (3m): 2110 & 2510 Shell Codes
 14' (4.3m): 2514 Shell Codes

RIG UNIT TO FINAL LOCATION

Rig the unit to its final location on the floor or mounting pad, lift the unit (or shell assembly) by means of an overhead lift and lower the unit to its mounting position. (If optional shipping skids are used, remove them before lowering the chiller to its mounting position.)

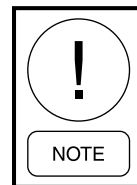

At this point units shipped dismantled should be assembled under the supervision of a Johnson Controls representative in accordance with the Reassembly section of this manual.

If evaporator is to be field insulated, the insulation can be applied to the evaporator while the unit is in the lift position to gain more access below the shell, if necessary. Be sure unit is properly supported. (Refer to *Insulation* in this section and *Figure 21* on page 32 for further information.)

INSTALL ISOLATORS

Neoprene isolator pads are furnished standard and typically satisfy the installation engineer's vibration isolation requirements when the chiller foundation is not likely to transmit to occupied spaces. Optional spring isolators can be selected when the location of the equipment room floor dictates more stringent limits on vibration input.

Neoprene Isolator Pads

Locate And Place Isolator Pads

The isolator pad mounts are to be located and placed rubber-side down as shown in *Figure 21* on page 32.

After the isolator pads have been placed into position on the floor, lower the chiller onto the pads. When the unit is in place, remove the rigging equipment and check that the unit is level.

Level The Unit

The longitudinal alignment of the unit should be checked by placing a level on the top center of the evaporator shell under the compressor/motor assembly. Transverse alignment should be checked by placing a level on top of the shell end sheets.

The unit should be level within 1/4" (6 mm) from one end to the other end and from front to the rear. If the chiller is not level within the amount specified, lift it and place shims between the isolation pad and the chiller tube sheets. (Shims are furnished by the installer.) Lower unit again and recheck to see that it is level

Checking The Isolation Pad Deflection

All isolation pads should be checked for the proper deflection while checking to see if the unit is level. Each pad should be deflected approximately 0.10 inches (2.5 mm) to 0.20 inches (5 mm). If an isolation pad is under-deflected, shims should be placed between the unit tube sheet and the top of the pad to equally deflect all pads.

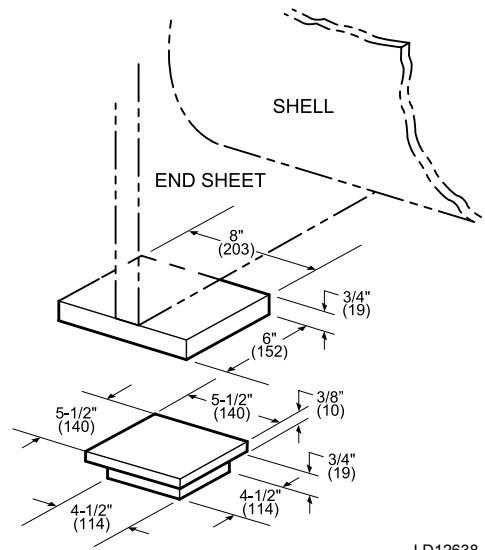

LD12638

UNIT WEIGHT UP TO 5,500 Lbs (2,494 Kgs)

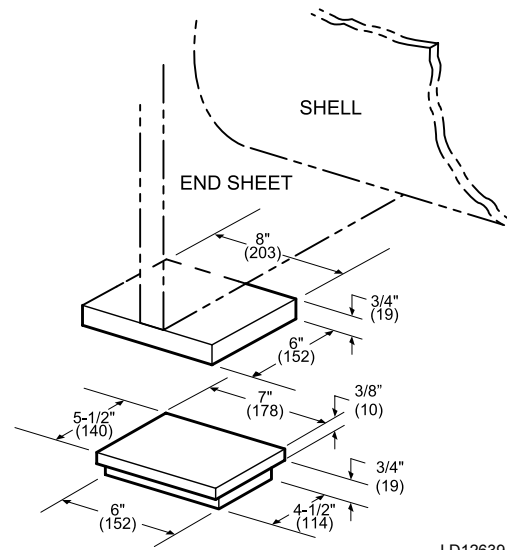

LD12639

UNIT WEIGHT 5,501 - 8,000 Lbs (2,495 - 3,628 Kgs)

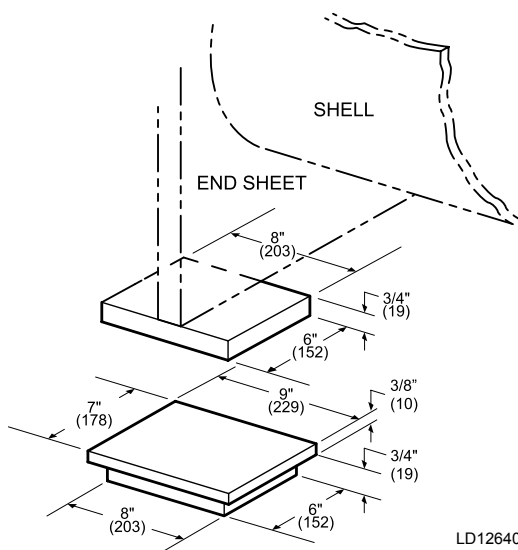

LD12640

UNIT WEIGHT 8,001 - 15,000 Lbs (3,629 - 6,804 Kgs)

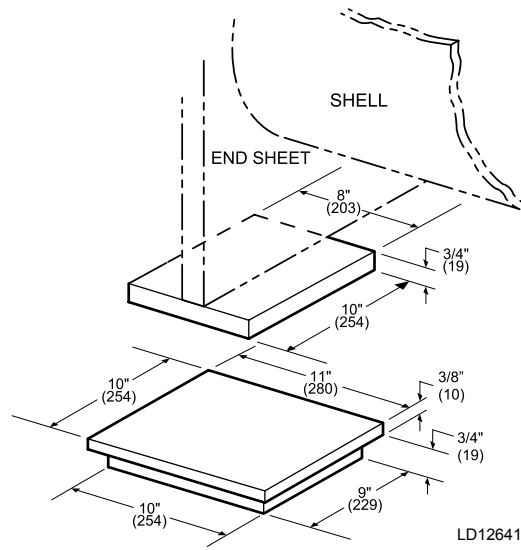

LD12641

UNIT WEIGHT 15,001 - 29,000 Lbs (6,805 - 13,154 Kgs)

FIGURE 21 - NEOPRENE ISOLATORS

NOTE: Dimensions are shown in Inches (mm)

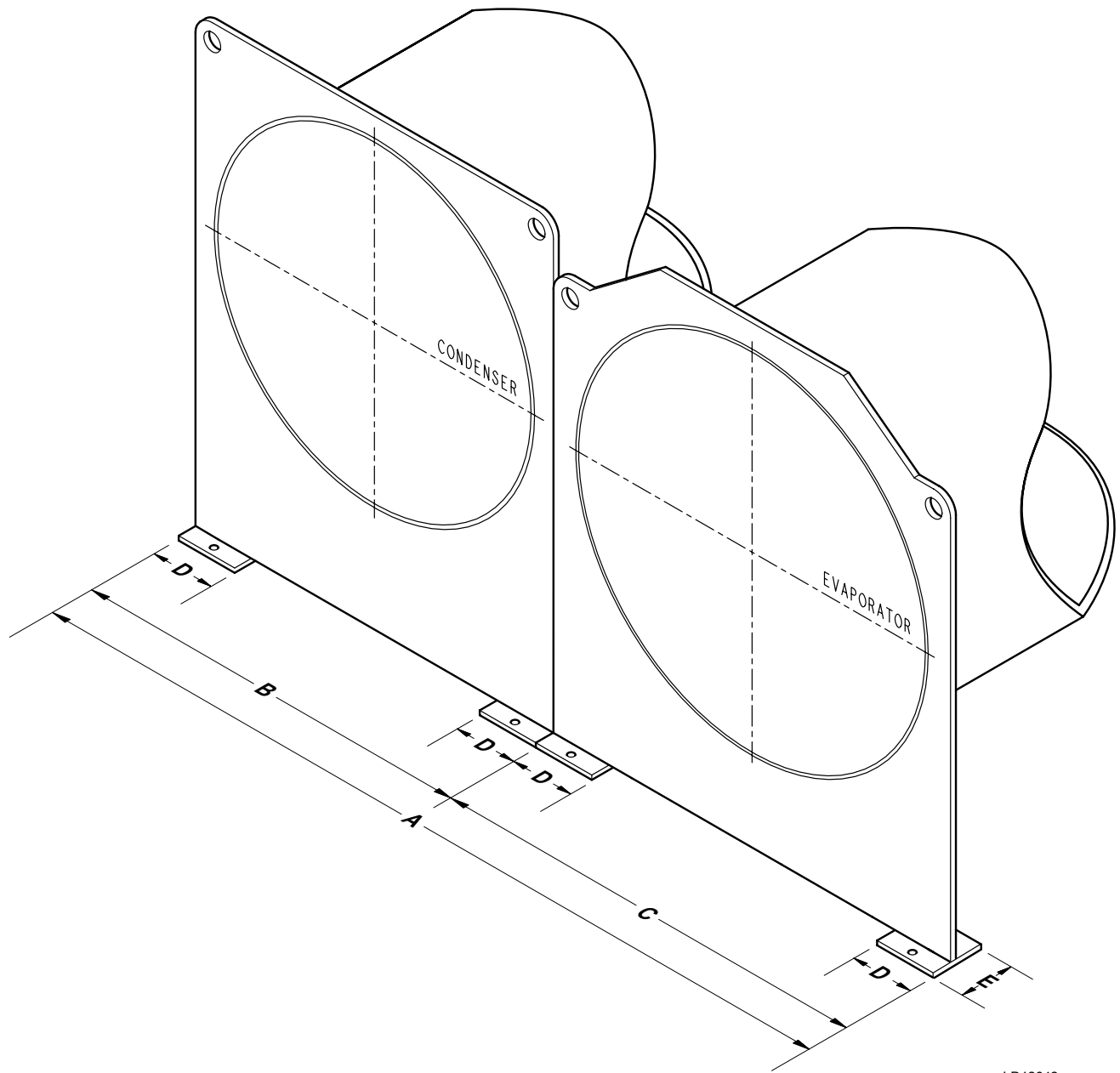

LD12642

OPERATING UNIT WEIGHT	DIM "A"	DIM "B"	DIM "C"	DIM "D"	DIM "E"
15,001 - 29,000 Lbs (6,805 - 13,154 Kgs)	62" (1575)	31" (787)	31" (787)	10" (254)	8" (203)

NOTE: Dimensions are shown in Inches (mm)

FIGURE 22 - NEOPRENE ISOLATORS

Install Optional Spring Isolators

Bolt Isolators To The Unit

If ordered, spring type isolator assemblies are furnished with the unit. The four assemblies are identical and can be placed at any of the four corners of the unit.

While the unit is still suspended by the rigging, the isolators should be bolted to the unit by inserting the cap screw(s) through the hole(s) in the mounting bracket into the tapped hole in the top of the isolator leveling bolt(s). Then the unit can be lowered onto the floor.

Level The Unit

The longitudinal alignment of the unit should be checked by placing a level on the top center of the evaporator shell under the compressor/motor assembly. Transverse alignment should be checked by placing a level on top of the shell end sheets.

Rotate the leveling bolts one turn at a time, in sequence, until the unit end sheets are clear of the floor by the dimension shown in *Figure 23 on page 34* and the unit is level. If the leveling bolts are not long enough to level unit due to an uneven or sloping floor or foundation, steel shims (grouted, if necessary) must be added beneath the isolator assemblies as necessary.

If the springs are over-compressed at any corner, the levelling bolt has been extended too far compared to at least one of the other corners on the same endsheet or same side of the shell and the isolator is bearing an unequal amount of the chiller load. Correct by backing off the bolts on the overloaded isolator and adjusting opposite isolators as required.

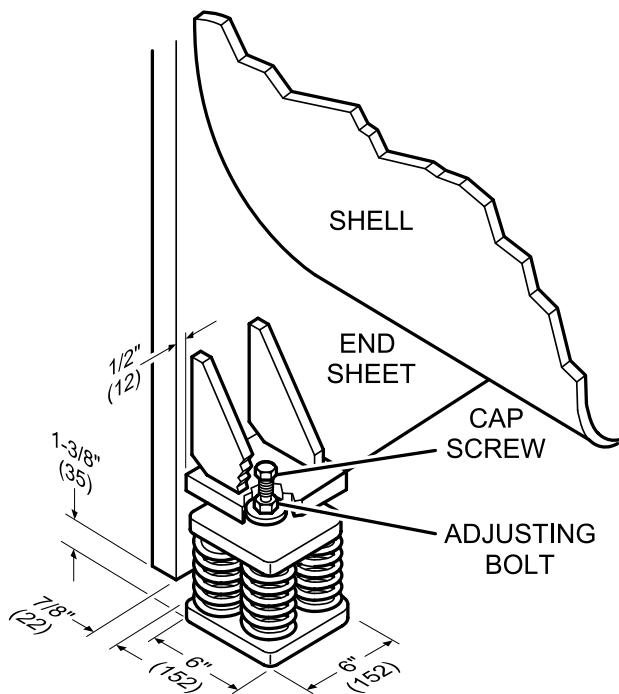

4-SPRING ISOLATORS

LD126544

UNIT WEIGHT

Up To 35,009 Lbs (15,880 Kgs)

FIGURE 23 - SPRING ISOLATORS

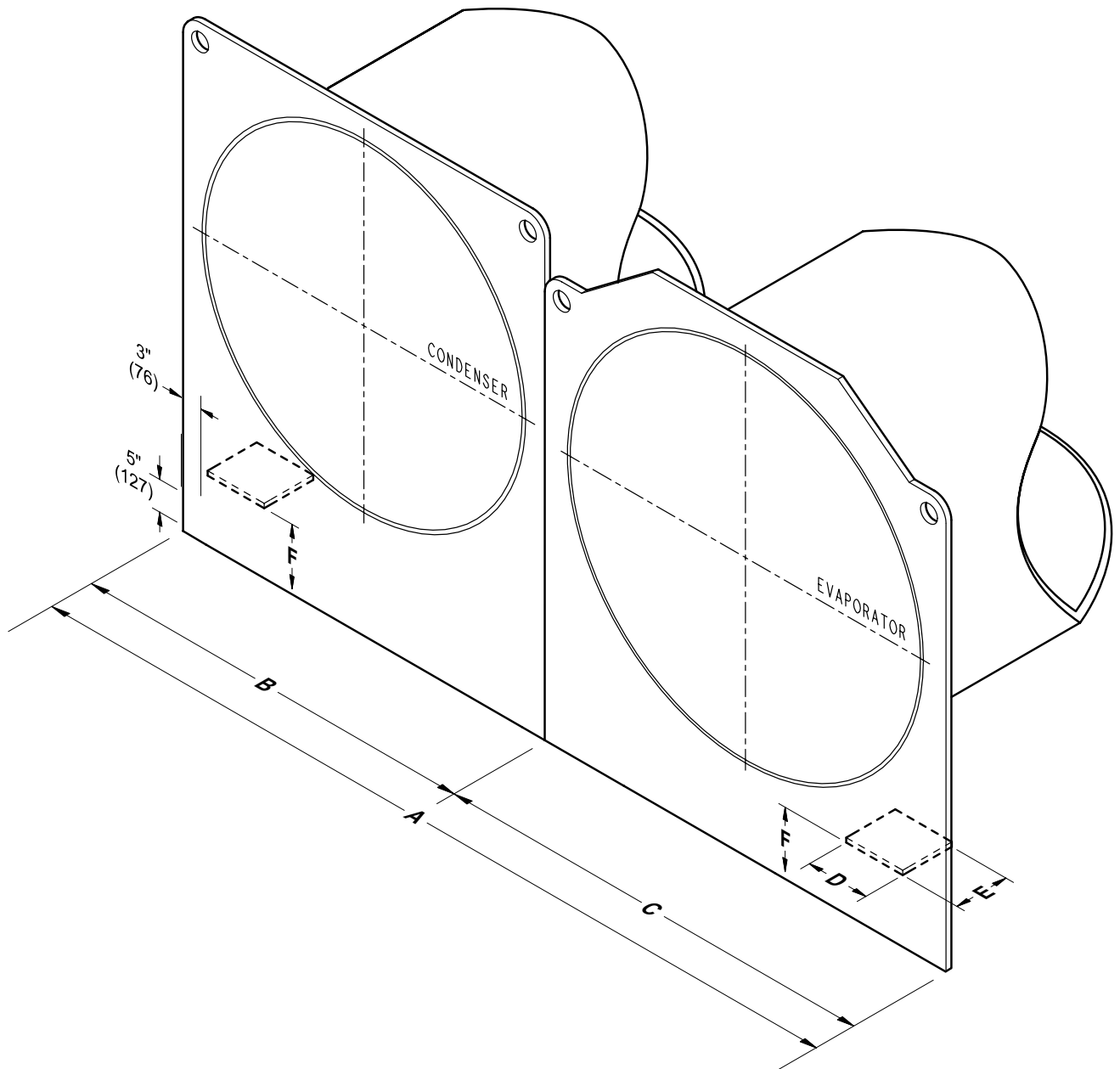

LD12643

OPERATING UNIT WEIGHT	DIM "A"	DIM "B"	DIM "C"	DIM "D"	DIM "E"	DIM "F"
Up to 35,000 Lbs (15,880 Kgs)	62" (1575)	31" (787)	31" (787)	6" (152)	6-7/8" (175)	5-1/2" (140)

NOTE: Dimensions are shown in Inches (mm)

FIGURE 24 - SPRING ISOLATORS

MAKE CONNECTIONS

After the unit is leveled, place wedges and/or shims under each corner to solidly support the unit in this position while connecting and hanging the piping, adjusting the connections, and checking for proper alignment.

The coolant temperature inside any JCI-supplied liquid-cooled motor starter must be maintained above the dewpoint temperature in the equipment room to prevent condensing water vapor inside the starter cabinet. Therefore, an additional temperature-controlled throttle valve is needed in the flow path for the starter heat exchanger to regulate cooling above the equipment room dewpoint for applications using cooling sources other than evaporative air-exchange methods, such as wells, bodies of water, and chilled water. The temperature control valve should be the type to open on increasing drive coolant temperature, fail-closed, and set for a temperature above dewpoint. It can be requested as factory-supplied on a chiller order by special quotation.

Piping Connections

After the unit is leveled (and wedged in place for optional spring isolators) the piping connections may be made; chilled water, condenser water and refrigerant relief. The piping should be arranged with offsets for flexibility, and adequately supported and braced independently of the unit to avoid strain on the unit and vibration transmission refer to *Figure 26 on page 37*. Hangers must allow for alignment of pipe. Isolators (by others) in the piping are highly desirable, and may be required by specifications, in order to effectively utilize the vibration isolation characteristics of the vibration isolation mounts of the unit. Piping connecting to chillers on spring isolators should be isolated with properly aligned and supported flexible connections. Otherwise, the piping joint becomes the primary resistance to motion and pipe or fittings are likely to deform or fatigue during operation.

Check for strain on piping – It is critical that no strain is present on the relief valve when the piping is connected. Any strain must be eliminated to minimize the potential to deform the seal surfaces and cause a leak. When checking for piping stress in Pressure Relief Piping:

1. Perform a visual inspection of the existing piping to determine if there are any clear signs of strain present.

2. Disconnect piping at flange or union connection if possible. When the piping is disconnected, there should be no springing or movement noted. The piping system must be self supported and in perfect alignment with the relief valves.

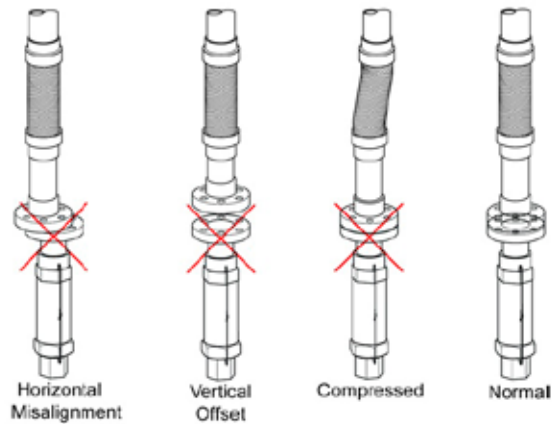

LD17201

FIGURE 25 - PRESSURE RELIEF PIPING

Check for piping alignment – Upon completion of piping, a connection in each line as close to the unit as possible should be opened, by removing the flange bolts or coupling and checked for piping alignment. If any of the bolts are bound in their holes, or if the connection springs are out of alignment, the misalignment must be corrected by properly supporting the piping or by applying heat to anneal the pipe.

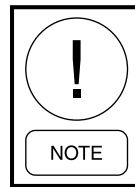

If the piping is annealed to relieve stress, the inside of the pipe must be cleaned of scale before it is finally bolted in place.

After the connections are made the unit can be filled with water and checked for leaks.

If spring isolators were installed, final adjustments can be made to the leveling bolts until the wedges and shims can be removed. The unit should now be in correct level position, clear of the floor or foundation and without any effect from the weight of the piping.

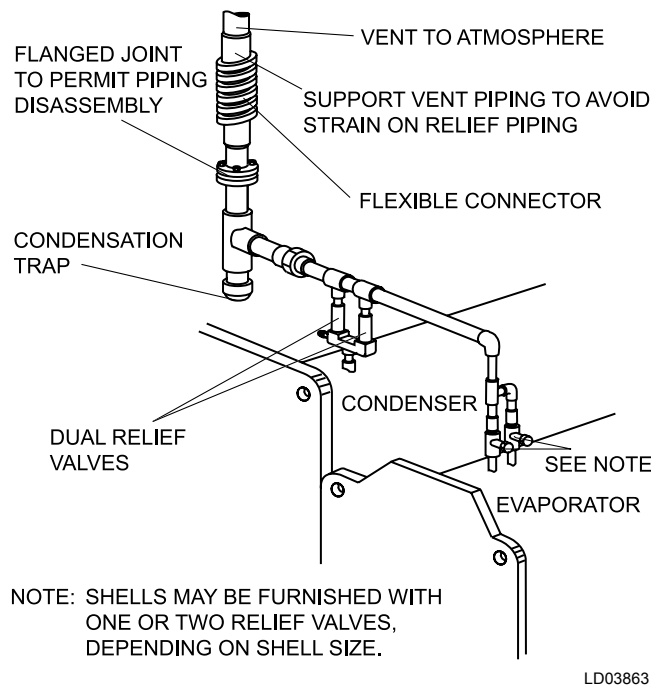

FIGURE 26 - TYPICAL REFRIGERANT VENT PIPING

Evaporator And Condenser Water Piping

The evaporator and condenser liquid heads of chiller have nozzles which are grooved, but also suitable for welding 150 psig DWP flanges or the use of flexible couplings. Factory mounted flanges are optional. If welding is done on the nozzles, flow switches, condenser level sensor, and water temperature thermistors should be disconnected and the welding ground **MUST** be good contact located at the head to prevent current damage to the devices.

The nozzles and water pass arrangements are furnished in accordance with the job requirements (see Product Drawings furnished with the job.) Standard units are designed for 150 psig DWP on the water side. If job requirements are for greater than 150 psig DWP, check the unit data plate before applying pressure to evaporator or condenser to determine if the chiller has provisions for the required DWP.

Inlet and outlet connections are identified by labels placed adjacent to each nozzle.

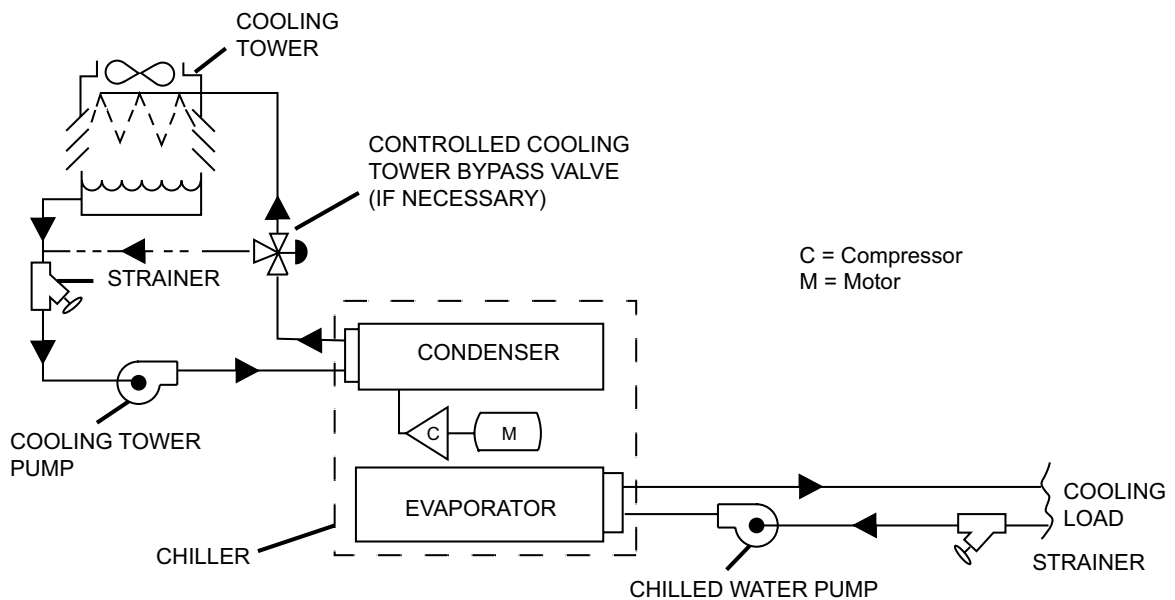

FIGURE 27 - SCHEMATIC OF A TYPICAL PIPING ARRANGEMENT

LD08529a

Chilled Water

Foreign objects which could lodge in, or block flow through, the evaporator and condenser tubes must be kept out of the water circuit. All water piping must be cleaned or flushed **before** being connected to the chiller pumps, or other equipment.

Permanent strainers (supplied by others) are required in both the evaporator and condenser water circuits to protect the chiller as well as the pumps, tower spray nozzles, chilled water coils and controls, etc. The strainer must be installed in the entering chilled water and condenser liquid line, upstream and near to the chiller.

Water piping circuits should be arranged to avoid water voids to the chiller, and should be controlled as necessary to avoid rapid flow transients.

If pumps discharge through the chiller, the strainer may be located upstream from pumps to protect both pump and chiller. (Piping between strainer, pump and chiller must be very carefully cleaned before start-up.) If pumps are remotely installed from chiller, strainers should be located directly upstream of the chiller.

Condenser Water Circuit

For proper operation of the unit, condenser refrigerant pressure must be maintained above evaporator pressure. If operating conditions will fulfill this requirement, no attempt should be made to control condenser water temperature by means of automatic valves, cycling of the cooling tower fan, or other means, since chillers are designed to function satisfactorily and efficiently when condenser water is allowed to seek its own temperature level at reduced loads and off-peak seasons of the year. However, if it is possible for the entering condenser water temperature to go below the required minimum, condenser water temperature must be maintained equal to or slightly higher than the required minimum. Refer to the *YMC² Engineering Guide (Form 160.84-EG1)* for required minimum Condenser and Evaporator temperatures. Refer to *Figure 8* for typical water piping schematic.

Stop Valves

Stop valves may be provided (by others) in the evaporator and condenser water piping adjacent to the unit to facilitate maintenance. Thermometer wells and pressure taps should be provided (by others) in the piping as close to the unit as possible to facilitate operating check.

Flow Switches

Thermal type water flow switches are factory mounted in the chilled and condensed water nozzles and are factory wired to the OptiView™ Control Panel. These solid-state flow sensors have a small internal heating element and use the cooling effect of the flowing fluid to sense when flow has been established.

Waterbox Drain And Vent Valves

Drain and vent valves (by others) should be installed in the connections provided in the evaporator and condenser liquid heads. These connections may be piped to drain if desired. They will assist in proper fill and vent of the chiller waterside prior to starting pumps to ensure no voids exist that could cause damage from a water slug.

Checking Piping Circuits And Venting Air

After the water piping is completed, but before any water box insulation is applied. Tighten and torque to maintain between 30 and 60 ft. lbs. (41 and 81 N·m) the nuts on the liquid head flanges. Gasket shrinkage and handling during transit cause nuts to loosen. If water pressure is applied before tightening is done, the gaskets may be damaged and have to be replaced. Fill the chilled and condenser water circuits, operate the pumps manually and carefully check the evaporator and condenser water heads and piping for leaks. Repair leaks as necessary.

Before initial operation of the unit both water circuits should be thoroughly vented of all air at the high points.

Refrigerant Relief Piping

Each unit is equipped with pressure relief valves located on the condenser and on the evaporator for the purpose of quickly relieving excess pressure of the refrigerant charge to the atmosphere as a safety precaution in case of an emergency, such as fire.

Refrigerant relief vent piping (by others), from the relief valves to the outside of the building, is required by code in most areas and should be installed on all chillers. The vent line should be sized in accordance with the ANSI/ASHRAE-15, or local code. The vent line must include a dirt trap in the vertical leg to intercept and permit clean out and to trap any vent stack condensation. The piping **MUST** be arranged to avoid strain on the relief valves, using a flexible connection, if necessary.

Unit Piping

Compressor refrigerant piping and system external piping are factory installed on all units shipped assembled. On units shipped dismantled, the piping should be completed under the supervision of the Johnson Controls representative.

Control Wiring

On units shipped disassembled, after installation of the control center, control wiring must be completed between unit components and control center, variable speed drive and using wiring harness furnished. Refer to *YMC² Field Connections Manual (Form 160.84-PW1)*

Field wiring connections for commonly encountered control modifications (by others) if required, are shown in the *YMC² Unit Wiring and Field Control Modifications Manual (Form 160.84-PW2)*.

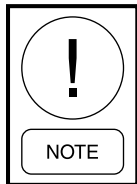

No deviations in unit wiring from that shown on drawings furnished shall be made without prior approval of the Johnson Controls representative.

Power Wiring

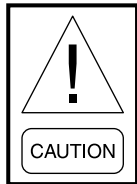

DO NOT cut wires to final length or make final connections to starter power input terminals until approved by the Johnson Controls representative.

Supplied Variable Speed Drive.

The factory mounted Variable Speed Drive does not require wiring to the compressor motor. The motor power wiring is factory connected to the Variable Speed Drive (refer to the *YMC² Unit Wiring and Field Control Modifications Manual (Form 160.84-PW2)*). All wiring to the control panel is completed by the factory. A control transformer is factory furnished with the Variable Speed Drive.

APPLY INSULATION

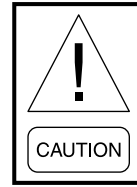

DO NOT field insulate until the unit has been leak tested under the supervision of the Johnson Controls representative.

Insulation of the type specified for the job, or minimum thickness to prevent sweating of 30°F (-1°C) surfaces should be furnished (by others) and applied to the evaporator shell, end sheets, liquid feed line to flow chamber, compressor suction connection, and evaporator liquid heads and connections (see *Figure 9*). The liquid head flange insulation must be removable, to allow head removal for the tube maintenance.

Units are furnished factory anti-sweat insulated on order at additional cost. This includes all low temperature surfaces except the two (2) cooler liquid heads.

INSTALLATION CHECK – REQUEST FOR STARTUP SERVICE

The services of a Johnson Controls representative will be furnished to check the installation and supervise the initial start-up and operation on all chillers installed within the Continental United States.

After the unit is installed, piped and wired as described in this Instruction, but before any attempt is made to start the unit, the Johnson Controls District Office should be advised so that the start-up service, included in the contract price, can be scheduled. Notify the Johnson Controls office using the *Installation Checklist and Request Form (Form 160.84-CL1)*.

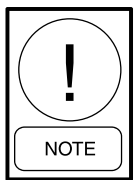
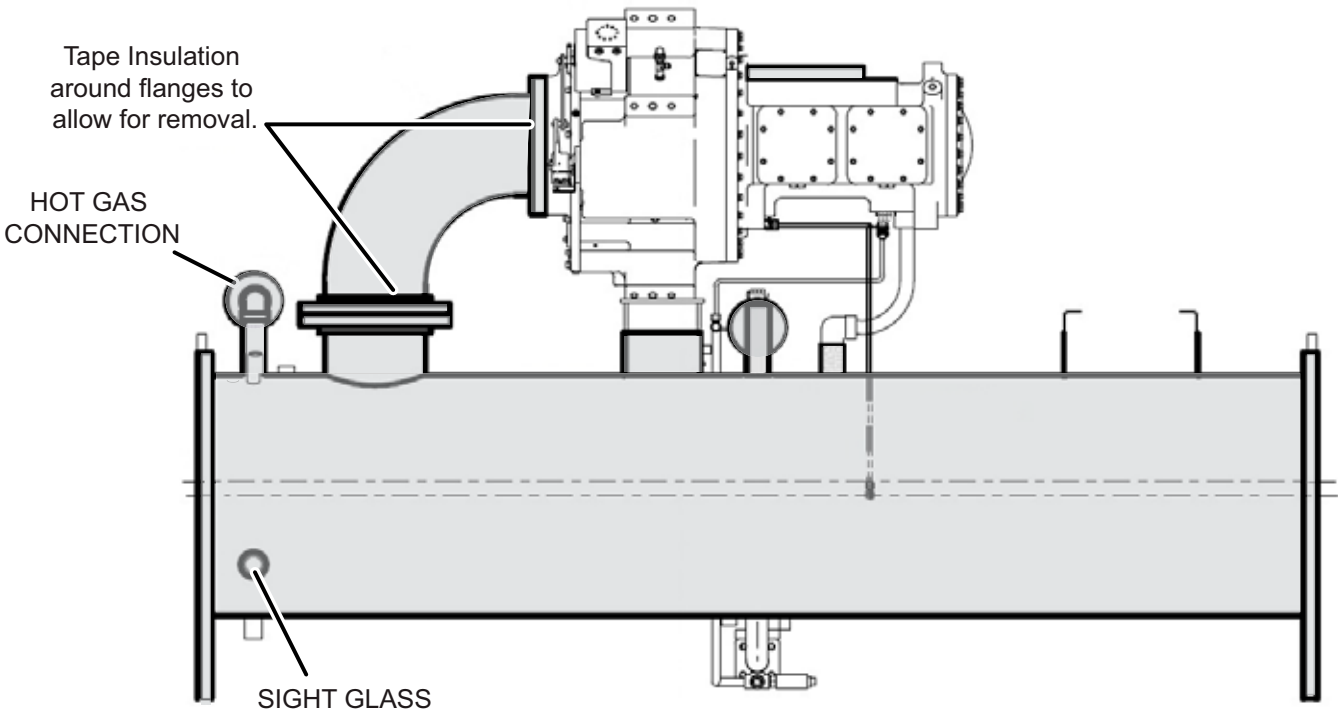
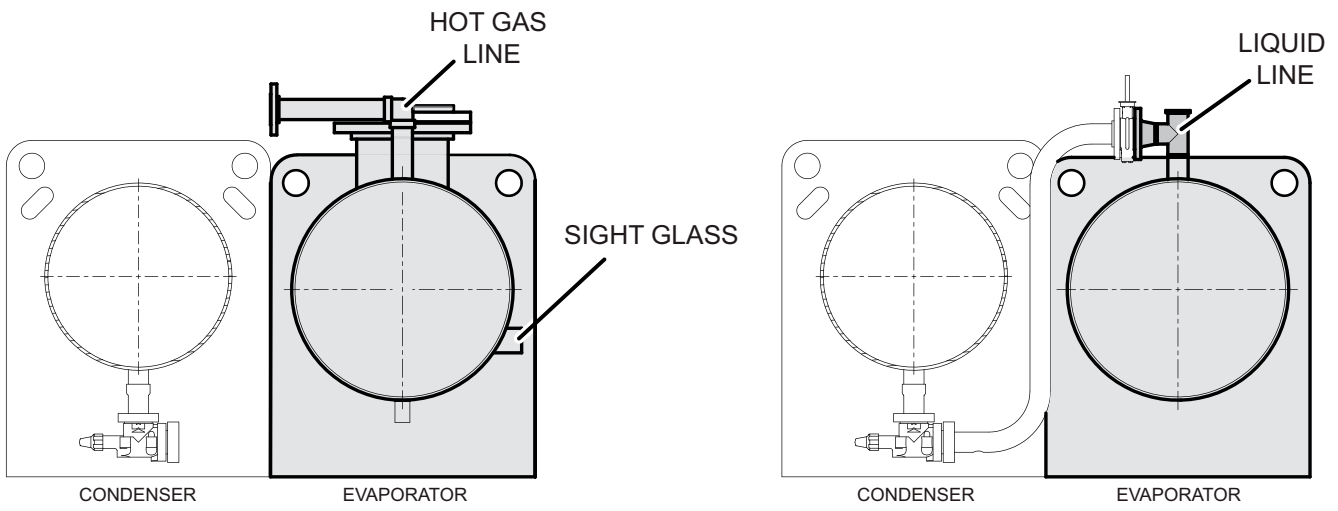

Bold lines and shaded components represent insulation.

FIGURE 28 - UNIT INSULATION

SECTION 4 - REASSEMBLY

FORM 3 and FORM 7 Reassembly

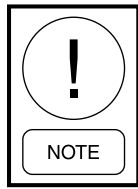

Refer to *Figure 30 on page 43*, *Figure 31 on page 44*, *Figure 32 on page 45*, *Figure 33 on page 46* and *Figure 34 on page 47* for reassembly hardware identification.

1. Rig shells according to the rigging section to final location. See *Section 2 - Rigging and Lifting*.
2. Bolt the tube sheets together as shown in *Figure 29 on page 41*. Note that the outside surfaces of the tube sheets must be flush.

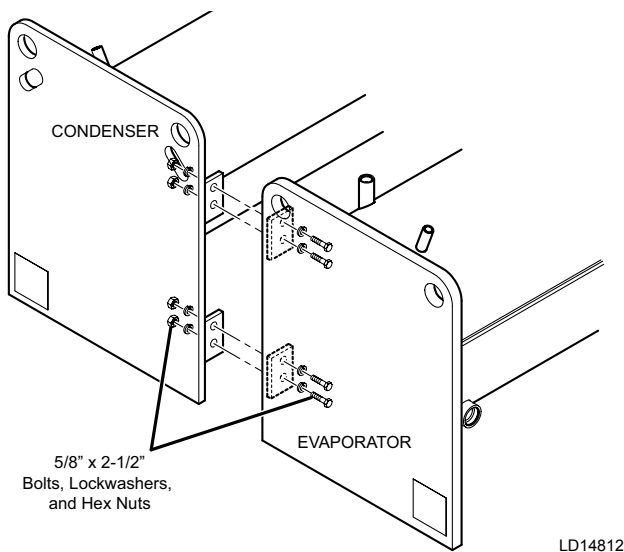

FIGURE 29 - SHELL REASSEMBLY

3. Assemble vibration isolators to unit. Refer to *Install Isolators on page 31*.
4. Level shells in both directions. The longitudinal alignment of the shell should be checked by placing a level on the top of the shell, next to the discharge connection. The transverse alignment should be checked by placing a level on the tops of both end sheets. Refer to *Section 3 - Installation on page 31* for additional instructions to level the unit. After shell is leveled, wedge and shim each corner of the shell to solidly support it while assembling the other parts.
5. Install the discharge piece and optional isolation valve between the compressor and the condenser using proper gaskets and hardware.

6. Lift compressor/motor assembly according to rigging section and remove packing materials. Carefully lower the compressor/motor assembly on to the discharge line and motor support on the evaporator. Fasten compressor/motor assembly with the proper hardware. Do not tighten the bolts until all connections are made to the compressor.
7. Bolt the suction line between the compressor and the evaporator using proper gaskets and hardware.
8. Complete the refrigerant liquid line piping between the evaporator and condenser. Be sure hardware are all properly installed.
9. Tighten all hardware installed in steps 3 through 6 above to the specified torque values provided in the reassembly figure.
10. Install refrigerant piping (*Refer to Refrigerant Tubing Reassembly on page 52*).
11. Pressure test the unit with nitrogen per Form 160.84-01.
12. Lift the Variable Speed Drive in accordance with rigging instructions and remove all packing material. Carefully lower the Variable Speed Drive on to the supports on the condenser. Fasten the Variable Speed Drive to the condenser. Make all necessary connections for the VSD cooling loop to be complete.

The Variable Speed Drive will be shipped with glycol in the cooling system. The Variable Speed Drive coolant must be changed to the inhibitor provided with the shipped loose items prior to starting the unit.

13. Lift the OptiView Control Center in accordance with rigging instructions and remove all packing material. Carefully lower the control panel on to the supports provided on the condenser. Fasten the Control Center to the condenser with the proper hardware.
14. Re-connect motor power leads in the Variable Speed Drive to T1, T2, and T3 terminals and torque to 18-20 Ft-lbs. per the labels in the VSD.
15. Connect the motor terminal box flex duct to the drive.

16. Lift the Power Panel in accordance with rigging instructions and remove all packing material. Carefully lower the Power Panel on to the evaporator. Assemble the Power Panel to the evaporator.
17. Re-connect all unit wiring and harnesses (refer to *YMC² Unit Wiring and Field Control Modifications (Form 160.84-PW2)*).
18. Remove Nitrogen and charge unit with Refrigerant. (Refer to Form 160.84-O1).
19. **All Units** – Complete installation and finally level the unit. (Refer *Section 3 - Installation on page 31*).

TABLE 12 - ASSEMBLY TORQUE METRIC FOR METRIC TUBE FITTINGS

FITTING SIZE	PORT-THREAD SIZE	TORQUE	
		FT-LB	N-M
M10	M10 x 1	17	23
M12	M12 x1.5	24	33
M14	M14 x 1.5	34	46
M16	M16 x 1.5	46	63
M18	M18 x 1.5	61	83
M22	M22 x 1.5	94	127
M27	M27 x 2	139	189
M30	M30 x 2	167	226
M33	M33 x 2	194	263
M42	M42 x 2	265	359
M48	M48 x 2	302	410
M60	M60 x 2	359	487

TABLE 13 - ASSEMBLY TORQUE ENGLISH FOR SAE TUBE FITTINGS

TUBE SIZE	SAE STRAIGHT THREAD SIZE (O-RING PART NUMBER)	SAE STRAIGHT THREAD TORQUE (FT-LBS.)	FACE SEAL TUBE-SIDE THREAD SIZE (O-RING PART NUMBER)	FACE SEAL TUBE-SIDE TORQUE (FT-LBS.)
1/4"	7/16-20 (028-12961-001)	25	9/16-18 (028-12961-011)	18
3/8"	9/16-18 (028-12961-003)	35	11/16-16 (028-12961-012)	30
1/2"	3/4-16 (028-12961-004)	60	13/16-16 (028-12961-013)	40
5/8"	7/8-14 (028-12961-005)	100	1-14 (028-12961-014)	60
3/4"	1 1/16-12 (028-12961-006)	135	1-3/16-12 (028-12961-015)	85
1"	1 5/16-12 (028-12961-008)	200	1-7/16-12 (028-12961-016)	110
1-1/4"	1 5/8-12 (028-12961-017)	250	1-11/16-12 (028-12961-022)	140
1-1/2"	1 7/8-12 (028-12961-020)	305	2-12-UN2A (028-12961-019)	180
**	2 1/4-12 (028-12961-)	225	-	-

NOTE:

** = SAE SIGHTGLASS

TABLE 14 - RE-ASSEMBLY TORQUE VALUES

		UNIT					
ITEM		DESCRIPTION	YORK PART NUMBER	SAP NUMBER	QUANTITY	TORQUE VALUE	
						FT-LBS.	N-M
A	4	HCS M24 X 3 X 90MM LG.	021-33185-090	731065	12	170	230
B	10	HCS M20 X 2.5 X 60MM LG.	021-33184-060	731063	1	470	640
C	13	HCS5 0.750-10 X 2.000 GR 5 ZN	021-32012-016	588676	8	50	68
D	30	HCS M6 X 1 X 16MM LG.	021-31205-016	730686	6	50	68
E	32	HCS M20 X 2.5 X 60MM LG.	021-33184-060	731063	12	95	130
F	38	NUT HEX 0.375-16 X GR 5 ZN.	021-32006-501	616900	6	50	68
HOT GAS							
G	7	HCS5 0.625-11 X 4.500 GR 5 ZN	021-32010-036	616908	4	65	88
LIQUID LINE							
H	5	HCS5 0.625-11 X 2.250 GR 5 ZN	021-32010-018	679632	8	50	68
END SHEETS (CON-EVAP ASSY)							
J	3	HCS5 0.625-11 X 2.500 GR 5 ZN	021-32010-020	616904	8	154	209
COMPRESSOR PIPING							
K	33	Hose, Motor Cooling 1-1/2" (Shell End)	Refer to TABLE 12/13 for Torque Specifications				
L	33	Hose, Motor Cooling M48x2 (Comp End)					
M	8	Metric, Connr 3/8 O.D. Tube M16x1.5					
N	15	Nut, 3/8 O.D. Tube					
VSD MOUNTING							
O	1	HCS5 0.438-14 X 1.250 GR 5 ZN	021-32007-010	730831	4	50	68
PANEL MOUNTING							
P	14	HCS5 0.250-20 X 1.000 GR 5 ZN	021-32004-008	730793	8	7	10

NOTES:

Unless otherwise specified, all screw must be tightened to the following torque values with lightly oiled threads.

** Lubricated with oil and graphite on male and female threads and under bolt heads. Do NOT use Moly-kote.

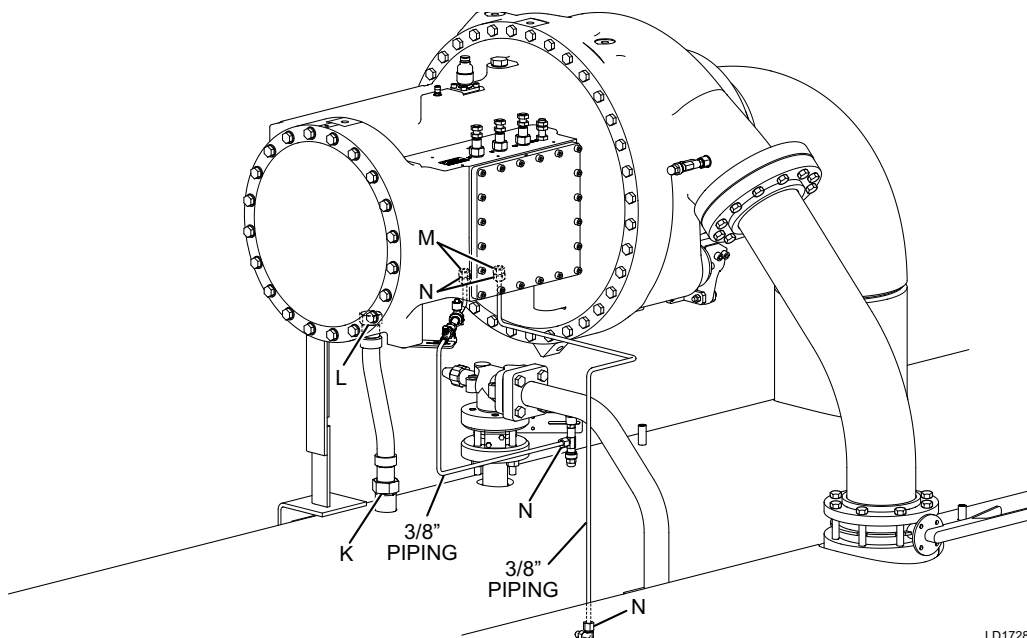
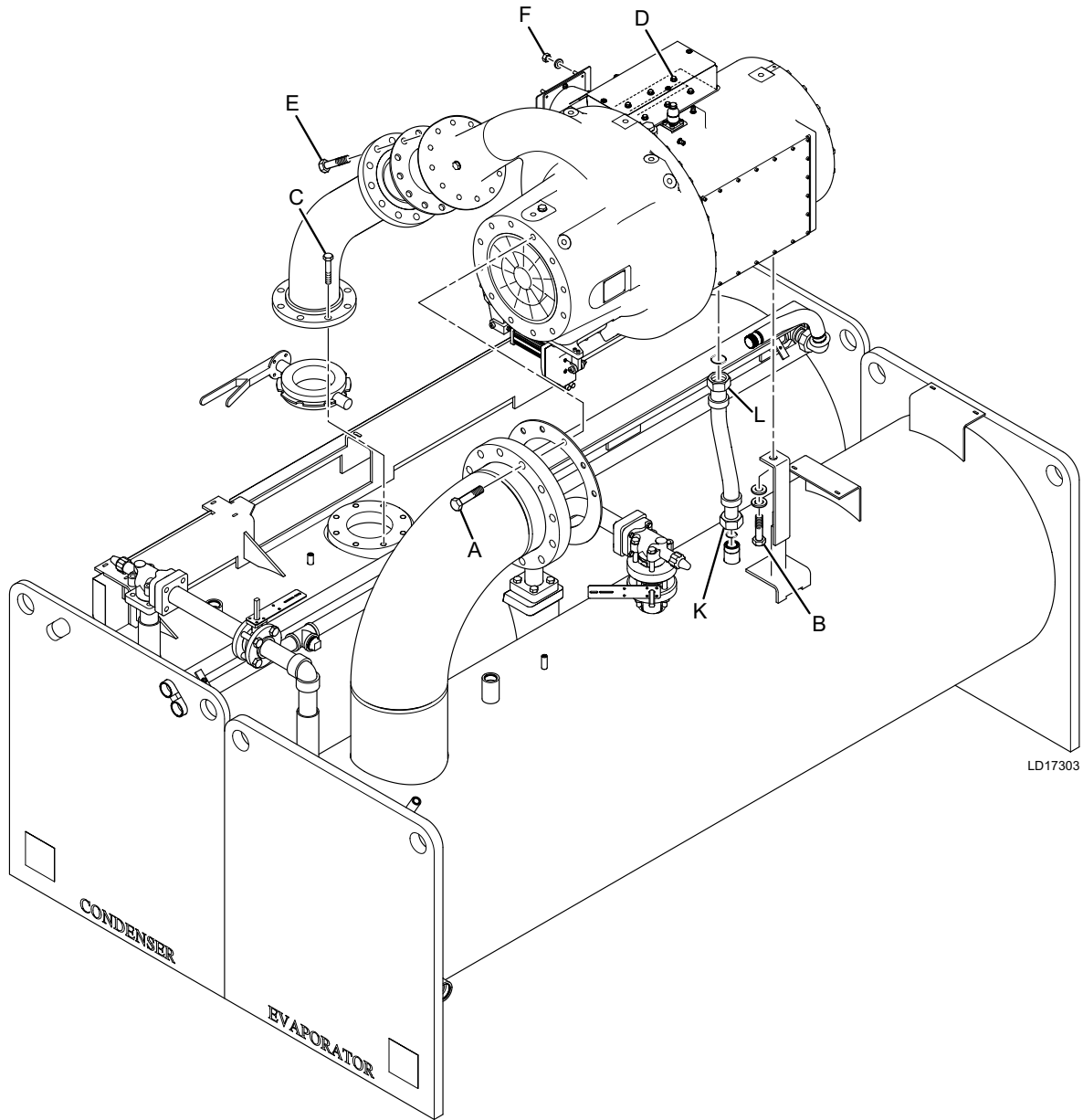

FIGURE 30 - YMC² PIPING REASSEMBLY HARDWARE IDENTIFICATION

LD17283



Refer to *Table 14* on *page 43* for the torque values.

LD17303

FIGURE 31 - YMC² FORM 3 REASSEMBLY HARDWARE IDENTIFICATION

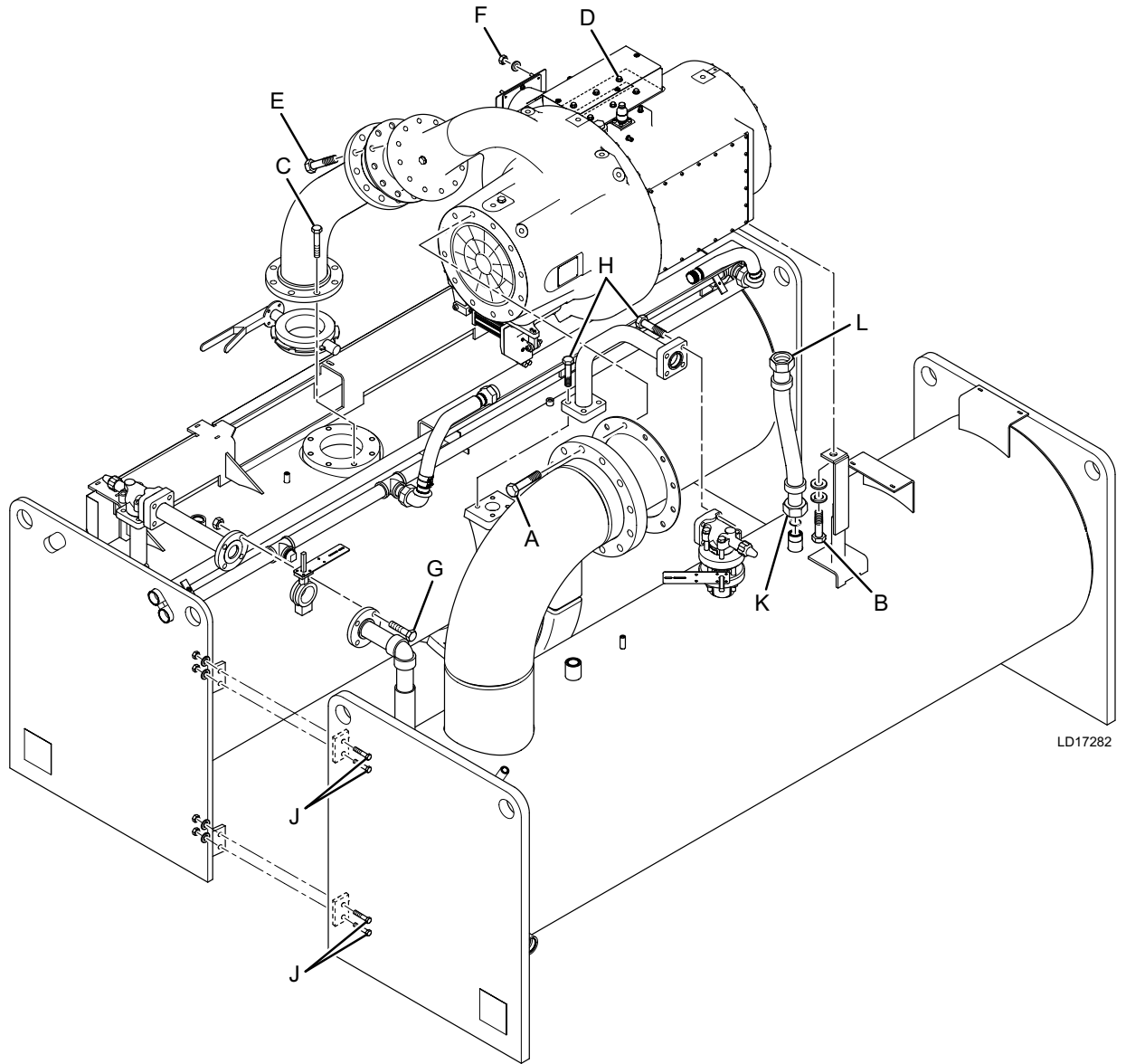

Refer to *Table 14* on *page 43* for the torque values.

LD17283

FIGURE 32 - YMC² FORM 7 REASSEMBLY HARDWARE IDENTIFICATION

Refer to *Table 14* on page 43 for the torque values.

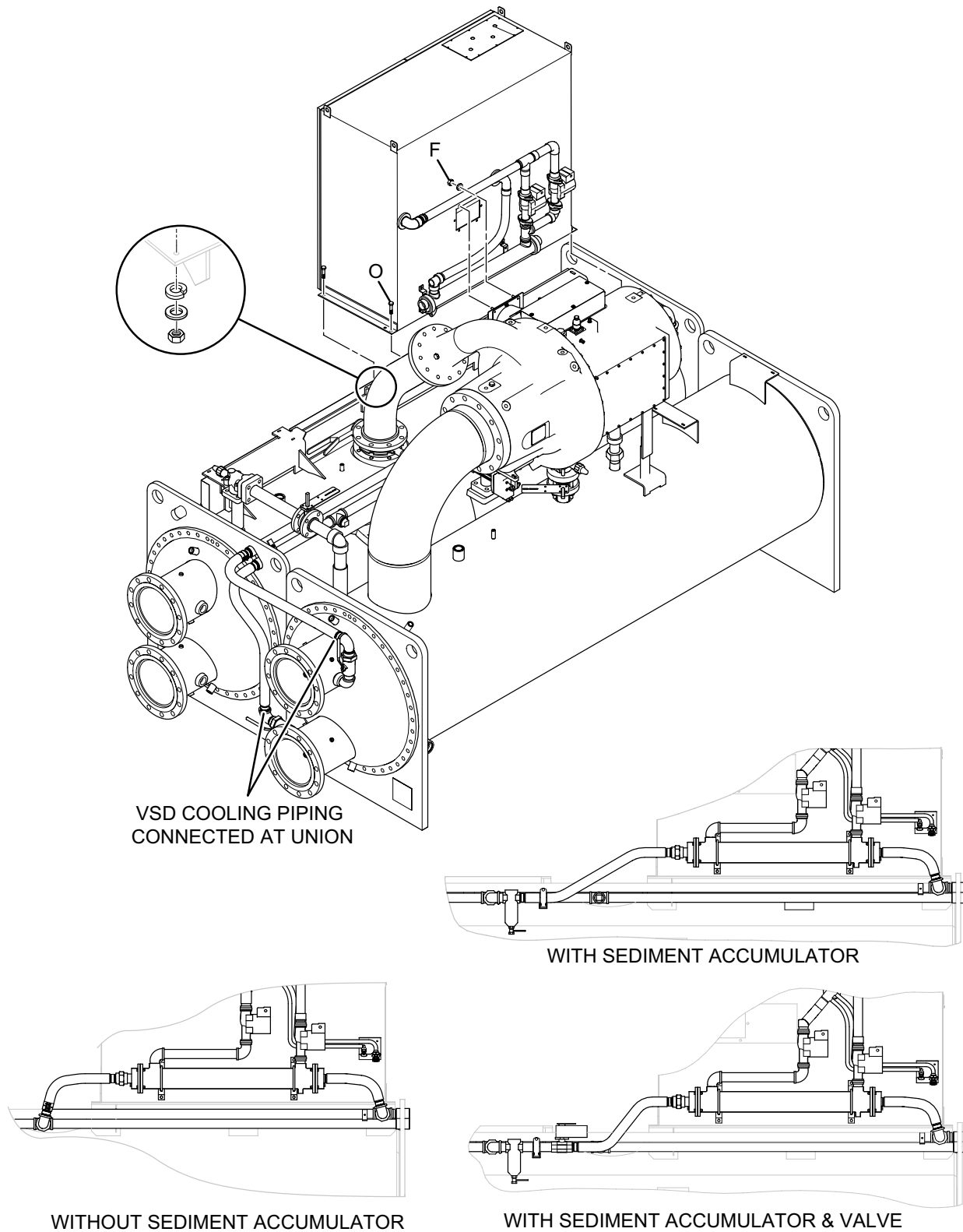

LD17284

FIGURE 33 - VSD MOUNTING HARDWARE IDENTIFICATION

Refer to *Table 14* on page 43 for the torque values.

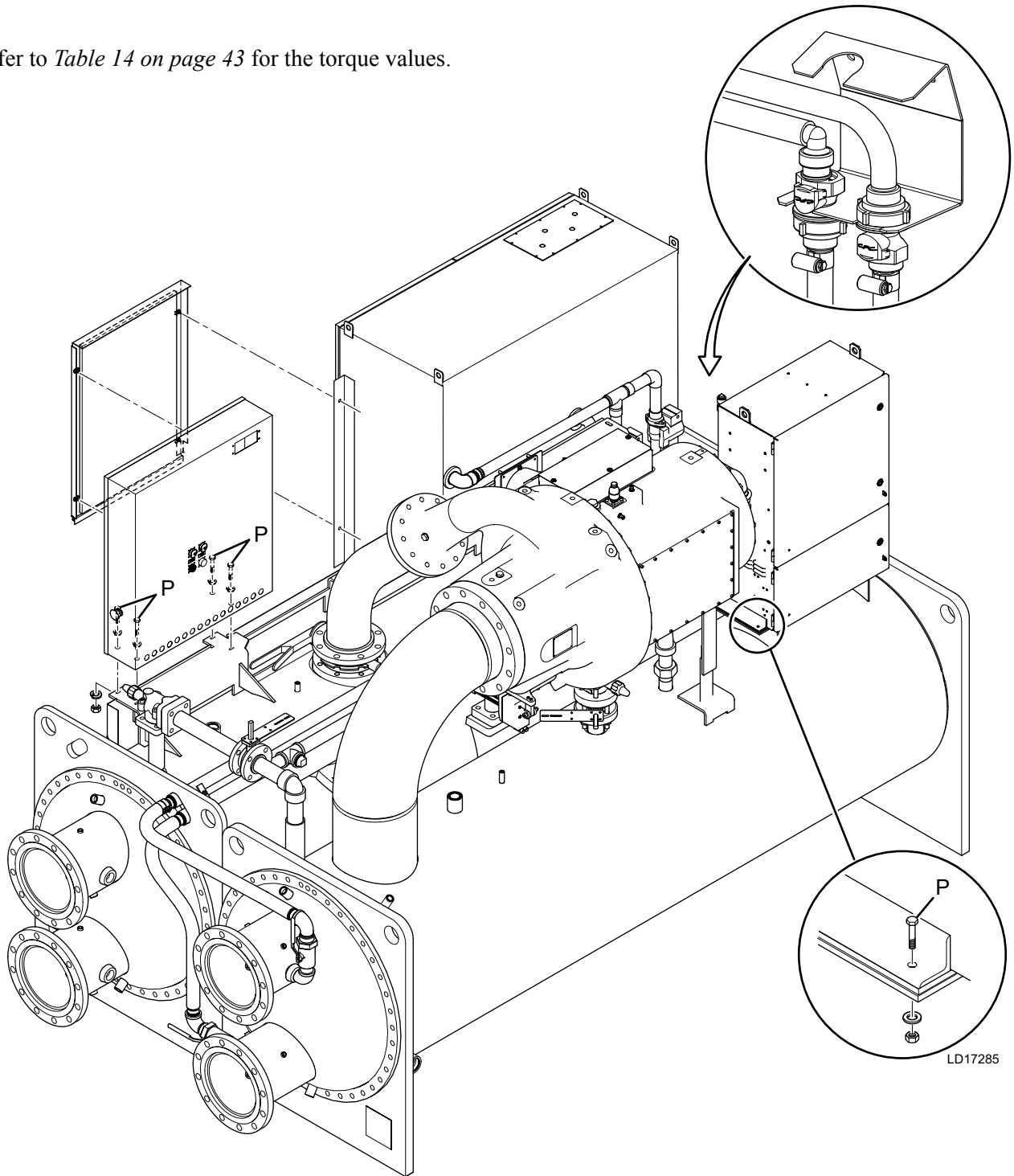

4

FIGURE 34 - POWER AND CONTROL PANEL MOUNTING HARDWARE IDENTIFICATION

FORM 9 and FORM 10 Reassembly

1. Assemble vibration isolators to unit. Refer *Section 3 - Installation on page 31*.
 2. Level shells in both directions. The longitudinal alignment of the shell should be checked by placing a level on the top of the shell, next to the discharge connection. The transverse alignment should be checked by placing a level on the tops of both end sheets refer to refer *Section 3 - Installation on page 31*. For additional instructions to level the unit. After shell is leveled, wedge and shim each corner of the shell to solidly support it while assembling the other parts.
 3. Tighten all hardware installed to the specified torque values provided in *Table 14 on page 43*.
 4. Lift the Variable Speed Drive in according to the rigging section and remove all packing material, for Variable Speed Drive. Carefully lower the Variable Speed Drive on to the supports on the condenser. Fasten the Variable Speed Drive to the condenser and to the motor terminal box duct. Make all necessary connections for the VSD cooling loop to be complete.
- The Variable Speed Drive will be shipped with glycol in the cooling system. The Variable Speed Drive coolant must be changed to the inhibitor provided with the shipped loose items prior to starting the unit.
5. Re-connect motor power leads in the Variable Speed Drive to T1, T2, and T3 terminals and torque to 18-20 Ft-lbs. per the labels in the VSD.
 6. Re-connect motor winding thermistor shielded cable conductors in the Variable Speed Drive at TB4 (*refer to YMC² Unit Wiring and Field Control Modifications (Form 160.84-PW2)*).
 7. Re-connect all unit wiring and harnesses (*refer to YMC² Unit Wiring and Field Control Modifications (Form 160.84-PW2)*).
 8. For Form 9 shipment remove Nitrogen and charge unit with Refrigerant (*refer Form 160.84-OM1*).
 9. **All Units** – Complete installation and finally level the unit. Refer *Section 3 - Installation on page 31*.

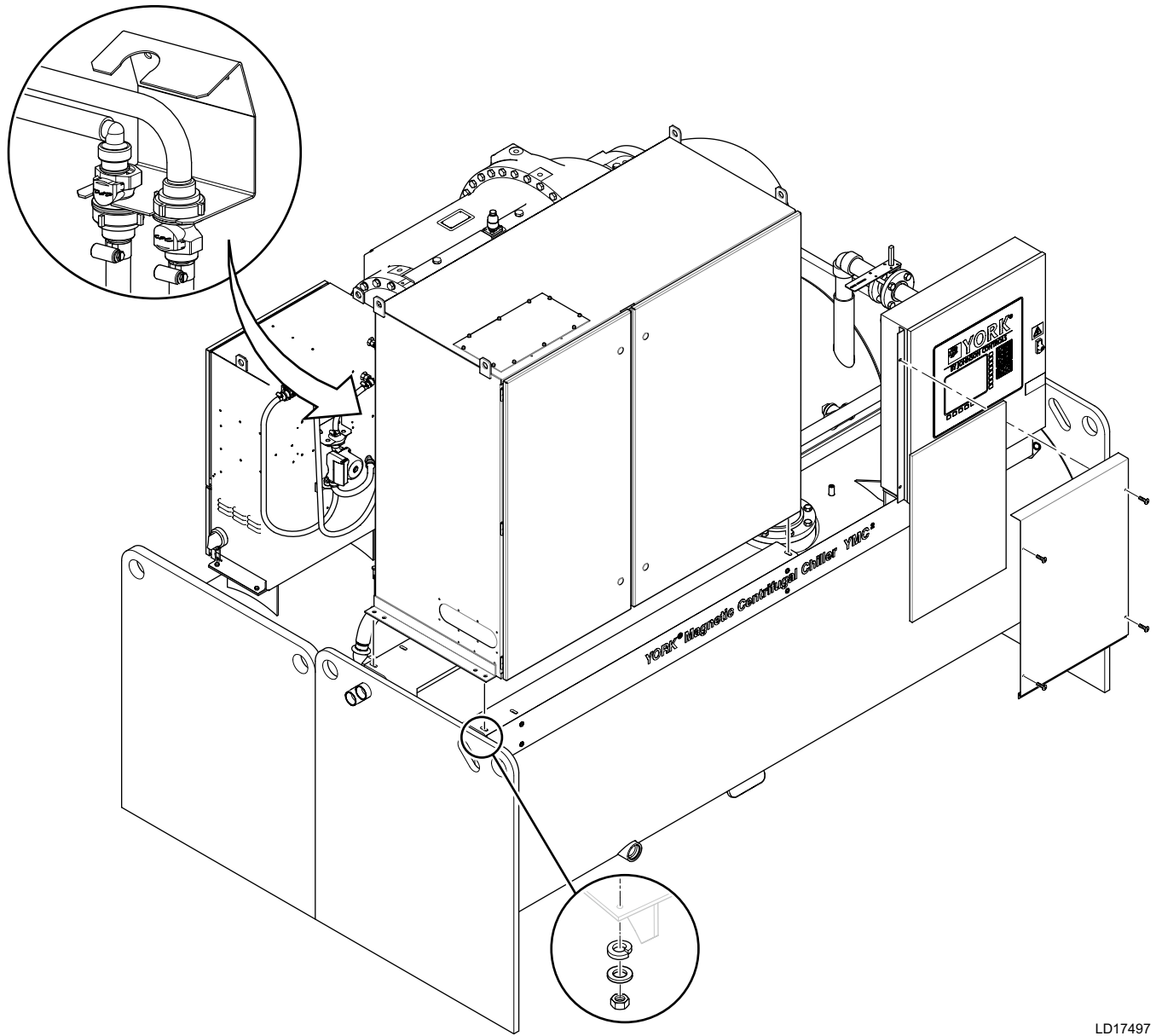

LD17497

FIGURE 35 - YMC² FORM 9 AND FORM 10 REASSEMBLY HARDWARE IDENTIFICATION

FORM 11 Reassembly

1. Bolt the tube sheets together as shown in *Figure 36 on page 50*. Note that the outside surfaces of the tube sheets must be flush.

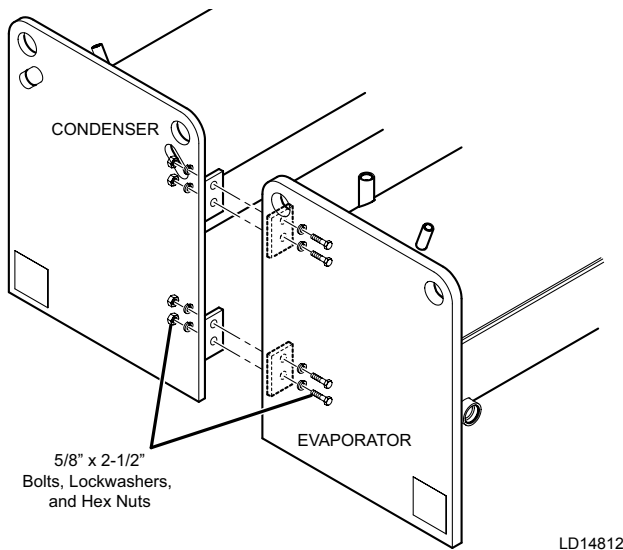

LD14812

FIGURE 36 - SHELL REASSEMBLY

2. Assemble vibration isolators to unit. Refer *Section 3 - Installation on page 31*.
3. Level shells in both directions. The longitudinal alignment of the shell should be checked by placing a level on the top of the shell, next to the discharge connection. The transverse alignment should be checked by placing a level on the tops of both end sheets. Refer *Section 3 - Installation on page 31* for additional instructions to level the unit. After shell is leveled, wedge and shim each corner of the shell to solidly support it while assembling the other parts.
4. Install the discharge piece and optional isolation valve between the compressor and the condenser using proper gaskets and hardware.
5. Complete the refrigerant liquid piping between the evaporator and condenser. Be sure hardware are all properly installed.

6. Tighten all hardware installed to the specified torque values provided on *Figure 38 on page 51*.
7. The Variable Speed Drive will be shipped with glycol in the cooling system. The Variable Speed Drive coolant must be changed to the inhibitor provided with the shipped loose items prior to starting the unit.
8. Re-connect motor power leads in the Variable Speed Drive to T1, T2, and T3 terminals and torque to 18-20 Ft-lbs. per the labels in the VSD.
9. Re-connect all unit wiring and harnesses (refer to *YMC² Unit Wiring and Field Control Modifications (Form 160.84-PW2)*).
10. Install refrigerant piping (refer to *Refrigerant Tubing Reassembly section of this manual for proper connection of O-ring fittings*).
11. Pressure test the unit with nitrogen per Form 160.84-O1.
12. Remove Nitrogen and charge unit with refrigerant (refer *Form 160.84-OM1*).

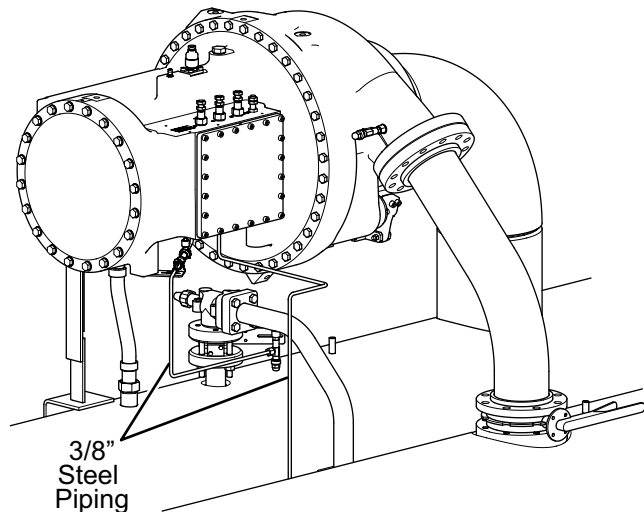

LD17280

FIGURE 37 - REFRIGERANT PIPING

13. Complete installation and finally level the unit per Installation Instruction. Refer *Section 3 - Installation on page 31*.

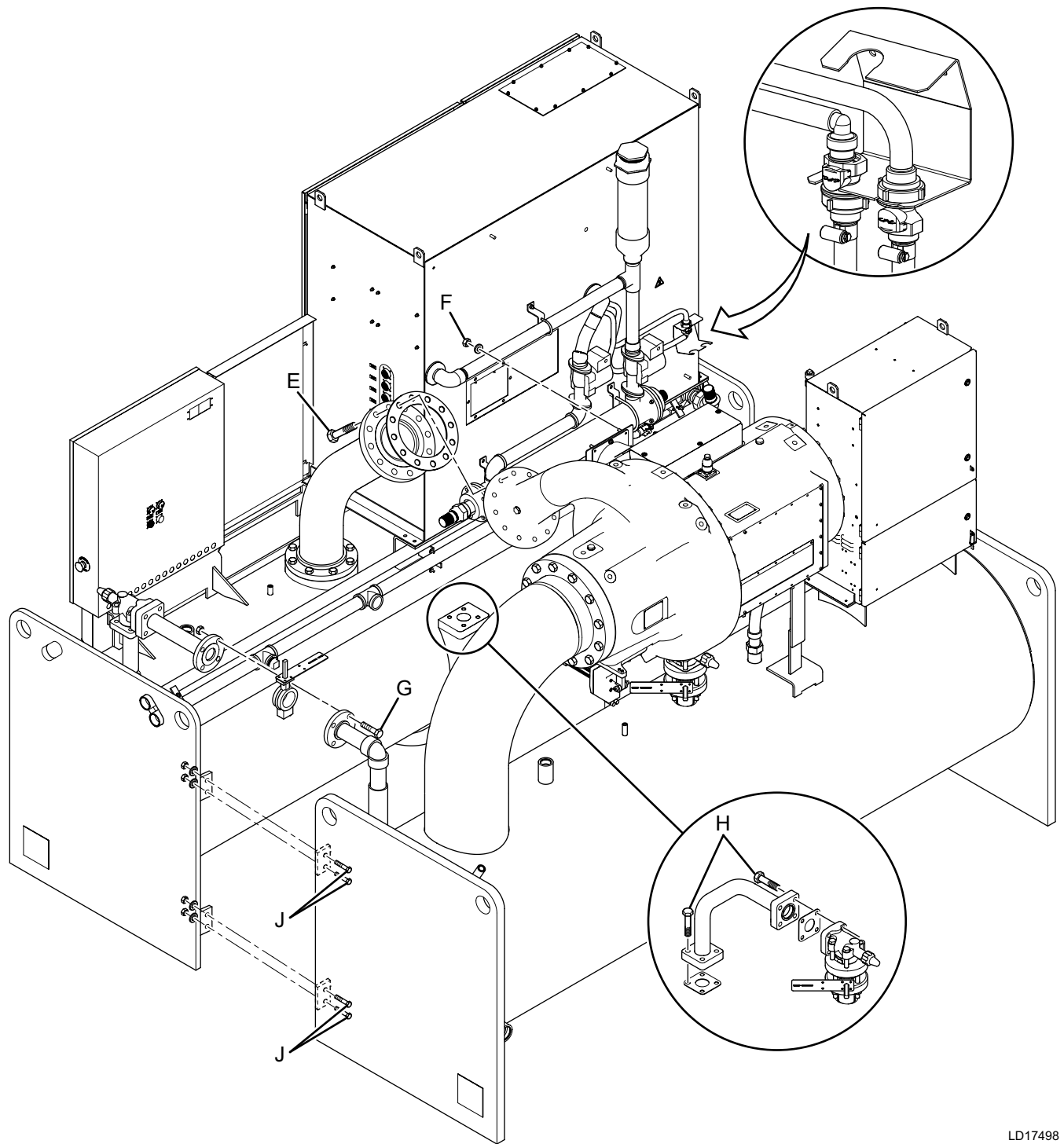

LD17498

FIGURE 38 - YMC² FORM 11 REASSEMBLY HARDWARE IDENTIFICATION

REFRIGERANT TUBING REASSEMBLY

The following is a step-by-step procedure to be used to reassemble the chiller refrigerant piping.

Assembly of Straight Thread O-ring Port Fittings

The male and female ends of SAE and ISO 6149 straight thread O-ring ports have UN/UNF or metric straight threads. An elastomeric O-ring is fitted to the male end. During assembly, the O-ring is firmly sandwiched between the angular sealing surface of the female port and the shoulder of the male end. Sealing is thus affected and maintained by the O-ring compression which results from the clamping force generated by tightening. The straight threads do NOT offer sealing action; they provide the resistance (holding power) for service pressure.

Adjustable End Assembly

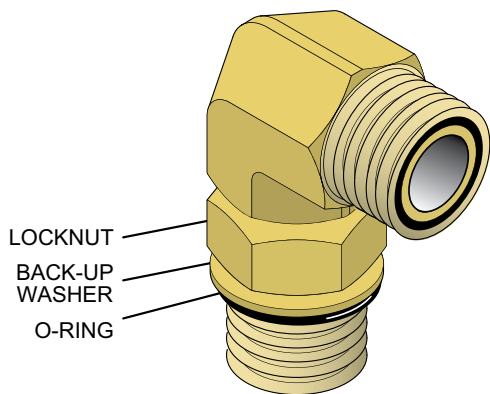

LD17269

FIGURE 39 - ADJUSTABLE END FITTING

1. Inspect to ensure that both matching parts are free of burrs, nicks, scratches or any foreign particles.
2. Install O-ring on port end of fitting, if it is NOT pre-installed, take care NOT to nick the O-ring.
3. Lubricate O-ring with a light coat of synthetic Polyolester (POE) oil or POE grease.
4. Back off locknut as far as possible. Make sure back-up washer is NOT loose and is pushed up as far as possible. This ensures the O-ring is completely at the back of the land so it remains in the land area when the fitting is turned out at Step 6.

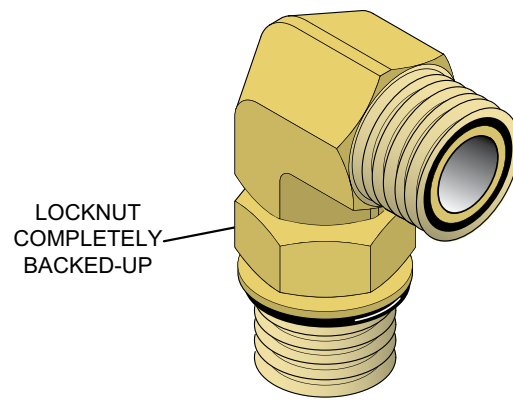

LD17270

FIGURE 40 - BACK OFF LOCKNUT

5. Screw fitting into port until the back-up washer contacts the face of the port. Light wrenching may be necessary.

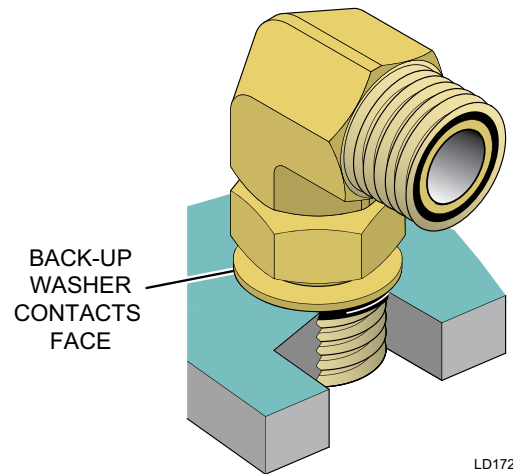

LD17271

FIGURE 41 - SCREW FITTING INTO PORT

6. To align the tube end of fitting to accept incoming tube or hose assembly, unscrew by required amount, but NOT more than one full turn. More than one turn makes the locknut push the O-ring into the machine threads beyond the fitting land area during step 7.
7. Using two wrenches, hold fitting in desired position and tighten locknut to the appropriate torque value shown in *Table 13 on page 42* or *Table 12 on page 42*.
8. Inspect to ensure that O-ring is NOT pinched and the back-up washer seats flat on face of port.

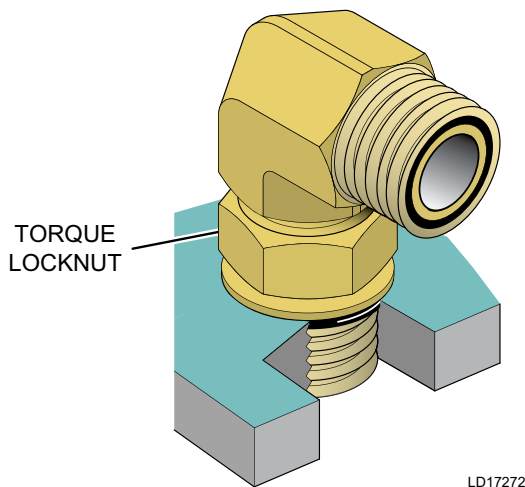

FIGURE 42 - TORQUE FITTING

Straight Non-Adjustable End Assembly

1. Inspect to ensure that both matching parts are free of burrs, nicks, scratches or any foreign particles.
2. Install O-ring on port end of fitting, if it is NOT pre-installed, use care NOT to nick the O-ring.
3. Lubricate O-ring with a light coat of synthetic Polyolester (POE) oil or POE grease.
4. Screw fitting into port until the hex flat contacts the port face. Light wrenching may be necessary.
5. Tighten to give torque for the specified size as specified in *Table 13 on page 42 or Table 12 on page 42.*

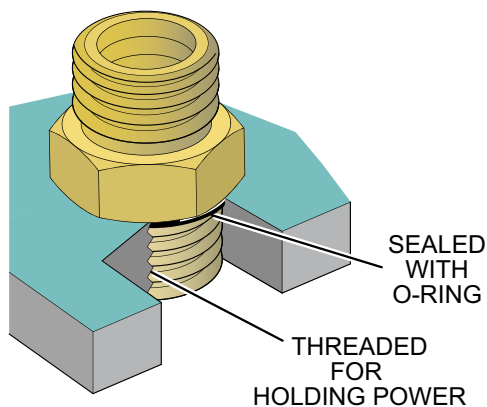

FIGURE 43 - SAE OR ISO 6149 STRAIGHT THREAD O-RING PORT

Assembly of O-ring Face Seal Fittings

The male end and female nut of face seal fittings have UN/UNF straight threads. An elastomeric O-ring is fitted into the grooved male end. During assembly, the O-ring is firmly sandwiched between the sealing surfaces. Sealing is thus affected and maintained by the O-ring compression which results from the clamping force generated by tightening the nut. The straight threads do NOT offer sealing action; they provide the resistance (holding power) for service pressure.

O-ring Face Seal Assembly

1. Inspect to ensure that both matching parts are free of burrs, nicks, scratches or any foreign particles.
2. Install O-ring in grooved face seal end of fitting, if it is NOT pre-installed, use care NOT to nick the O-ring.
3. Lubricate O-ring with a light coat of synthetic Polyolester (POE) oil or POE grease.
4. Thread the nut by hand, and tighten nut to the appropriate torque value shown in *Table 13 on page 42 or Table 12 on page 42.*

THIS PAGE INTENTIONALLY LEFT BLANK.

SECTION 5 - DIMENSIONS, NOZZLE ARRANGEMENTS AND WEIGHTS

COMPRESSOR UNIT DIMENSIONS

Additional Operating Height Clearance To Floor Ft - In (mm)	
Type Of Chiller Mounting	M
Neoprene Pad Isolators	1 - 3/4" (45)
Spring Isolators 1" Deflection	1" (25)
Direct Mount	3/4" (19)

EVAPORATOR CODE	CONDENSER CODE	DIMENSIONS - 197 - 246 COMPRESSOR UNITS FT - IN (MM)					
		A	B		C	D	E
			490 VSD	774 VSD			
EB2510	CB2110	5'-5-1/4" (1657)	6'-9-9/32" (2065)	7'-11- (2419)	1'-4-5/8" (406)	1'-4-5/8" (422)	10' (3048)
EB2510	CB2510	5'-5-1/4" (1657)	6'-7-11/16" (2024)	7'-9-11/16" (2380)	1'-4-5/8" (406)	1'-4-5/8" (422)	10' (3048)
EB2514	CB2514	5'-5-1/4" (1657)	6'-7-11/16" (2024)	7'-9-11/16" (2380)	1'-4-5/8" (406)	1'-4-5/8" (422)	14' (4267)
EB2910	CB2510	5'-7" (1702)	6'-9-15/16" (2081)	7'-9-5/8" (2378)	1'-4" (406)	1'-5-1/2" (445)	10' (3048)
EB2910	CB2910	5'-10" (1778)	7'-2-3/8" (2194)	8'-1-7/8" (2486)	1'-5-1/2" (445)	1'-5-1/2" (445)	10' (3048)
EB2914	CB2514	5'-7" (1702)	6'-9-15/16" (2081)	7'-9-5/8" (2378)	1'-4" (406)	1'-5-1/2" (445)	14' (4267)
EB2914	CB2914	5'-10" (1778)	7'-2-3/8" (2194)	8'-1-7/8" (2486)	1'-5-1/2" (445)	1'-5-1/2" (445)	14' (4267)
EB3310	CB2910	6'-2" (1880)	7'-2-3/8" (2194)	8'-1-7/8" (2486)	1'-5-1/2" (445)	1'-7-1/2" (495)	10' (3048)
EB3310	CB3310	6'-7" (2007)	7'-3-3/8" (2219)	8'-5-5/16" (2573)	1'-8" (508)	1'-7-1/2" (495)	10' (3048)
EB3314	CB2914	6'-2" (1880)	7'-2-3/8" (2194)	8'-1-7/8" (2486)	1'-5-1/2" (445)	1'-7-1/2" (495)	14' (4267)
EB3314	CB3314	6'-7" (2007)	7'-3-3/8" (2219)	8'-5-5/16" (2573)	1'-8" (508)	1'-7-1/2" (495)	14' (4267)

NOTES:

1. See Figure 44 on page 56 for dimension location points as designated on this table.
2. All dimensions are approximate. Certified dimensions are available on request.
3. Standard water nozzles are Schedule 40 pipe size, furnished as welding stub-outs with ANSI/AWWA C-606 grooves, allowing the option of welding, flanges, or use of ANSI/AWWA C-606 couplings. Factory-installed, class 150 (ANSI B16.5, round slip-on forged carbon steel with 1/16" raised face), water flanged nozzles are optional (add 1/2" to nozzle length). Companion flanges, nuts, bolts, and gaskets are not furnished.
4. One, two, and three-pass nozzle arrangements are available only in pairs shown for all shell codes. Any pair of evaporator nozzles may be used in combination with any pair of condenser nozzles Compact water boxes on one heat exchanger may be used with Marine Water Boxes on the other heat exchangers.
5. Condenser water must enter the water box through the bottom connection for proper operation of the sub-cooler to achieve rated performance.
6. To determine overall height, add dimension "M" for the appropriate isolator type.

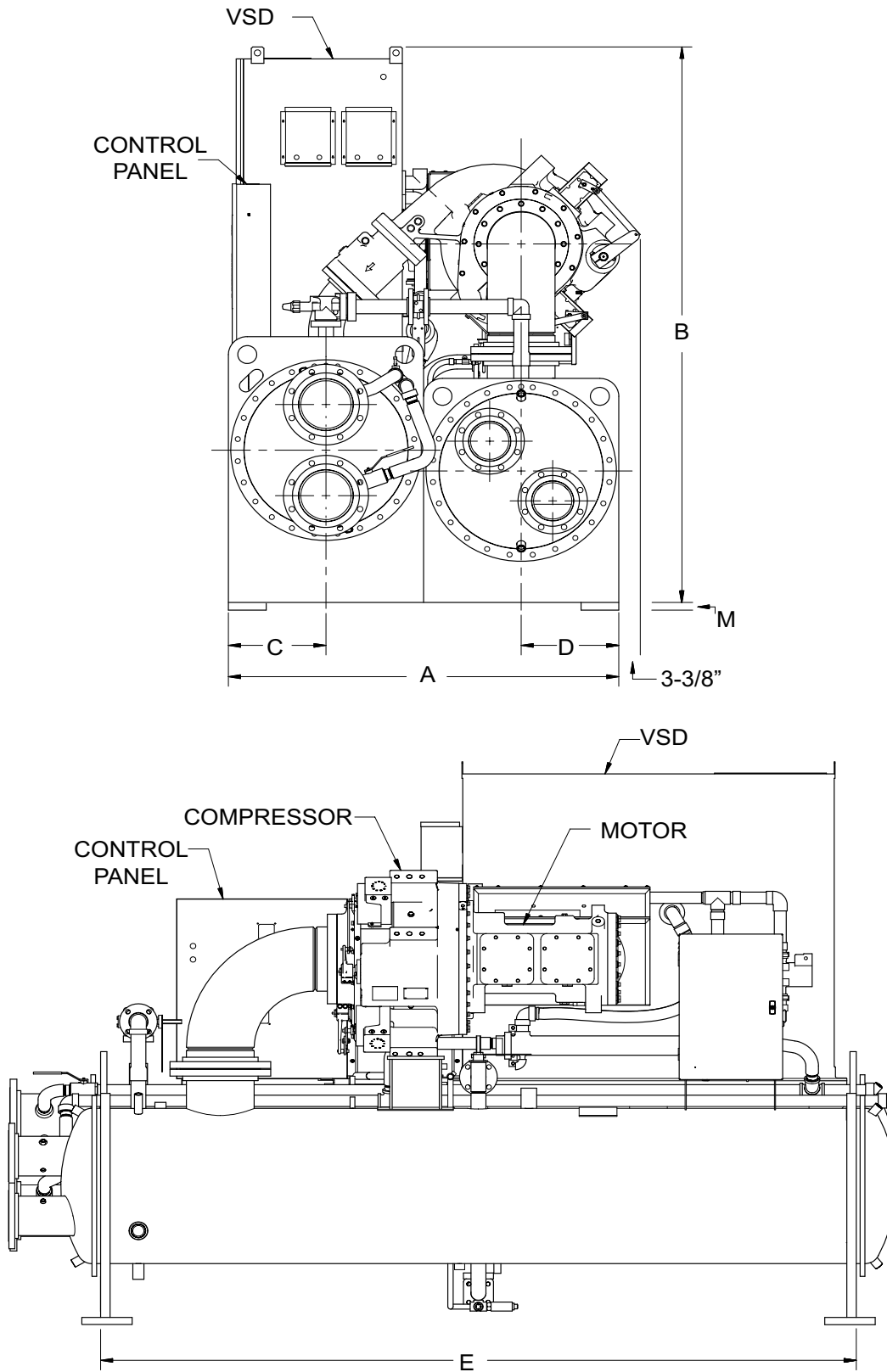
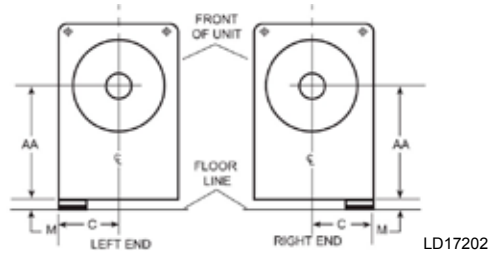

FIGURE 44 - DIMENSIONS - 197 & 246 COMPRESSOR UNITS FT-IN (MM)

LD17200

EVAPORATOR 150 & 300 PSI COMPACT WATER BOXES



1-Pass Evaporator Nozzle Arrangements	
In	Out
Left End	Right End
Right End	Left End

FIGURE 45 - EVAPORATOR - COMPACT WATER BOXES (1-PASS NOZZLE ARRANGEMENTS)

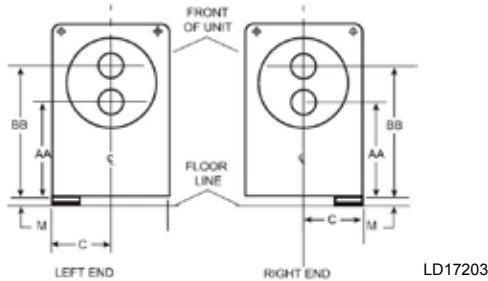

2-Pass Evaporator Nozzle Arrangements	
In	Out
Lower Right End	Upper Right End
Lower Left End	Upper Left End

FIGURE 46 - EVAPORATOR - COMPACT WATER BOXES (2-PASS NOZZLE ARRANGEMENTS)

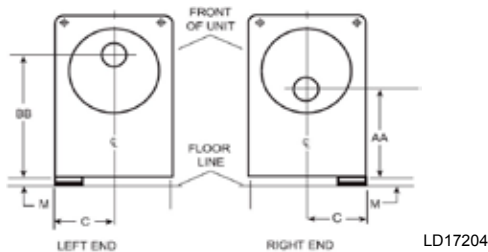

3-Pass Evaporator Nozzle Arrangements	
In	Out
Right End	Left End

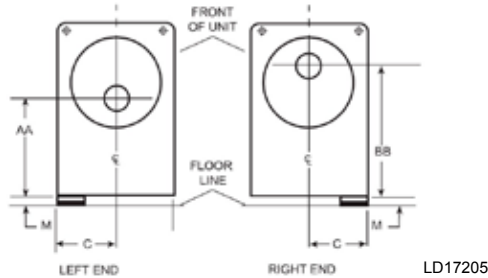

3-Pass Evaporator Nozzle Arrangements	
In	Out
Left End	Right End

FIGURE 47 - EVAPORATOR - COMPACT WATER BOXES (3-PASS NOZZLE ARRANGEMENTS)

COMPACT WATER BOXES-150 & 300 PSI DIMENSIONS									
Evaporator Shell Code	Nozzle Pipe Size Ft-In (mm)			Evaporator Nozzle Dimensions Ft-In (mm)					
	No. Of Passes			C	1-Pass	2-Pass		3-Pass	
	1	2	3		AA	AA	BB	AA	BB
EB25	8" (203)	6" (152)	4" (102)	1' - 4-5/8" (422)	1' - 10" (559)	1'-2" (356)	2'-6" (762)	1'-2" (356)	2'-6" (762)
EB29	10" (254)	8" (203)	6" (152)	1'-5-1/2" (445)	2' (610)	1'-3" (381)	2'-9" (838)	1'-4" (406)	2'-8" (813)
EB33	14" (356)	10" (254)	8" (203)	1'-7-1/2" (495)	2'-2" (660)	1'-4" (406)	3' (914)	1'-6" (457)	2'-10" (864)

NOTE: Dimensions are shown in Inches (mm)

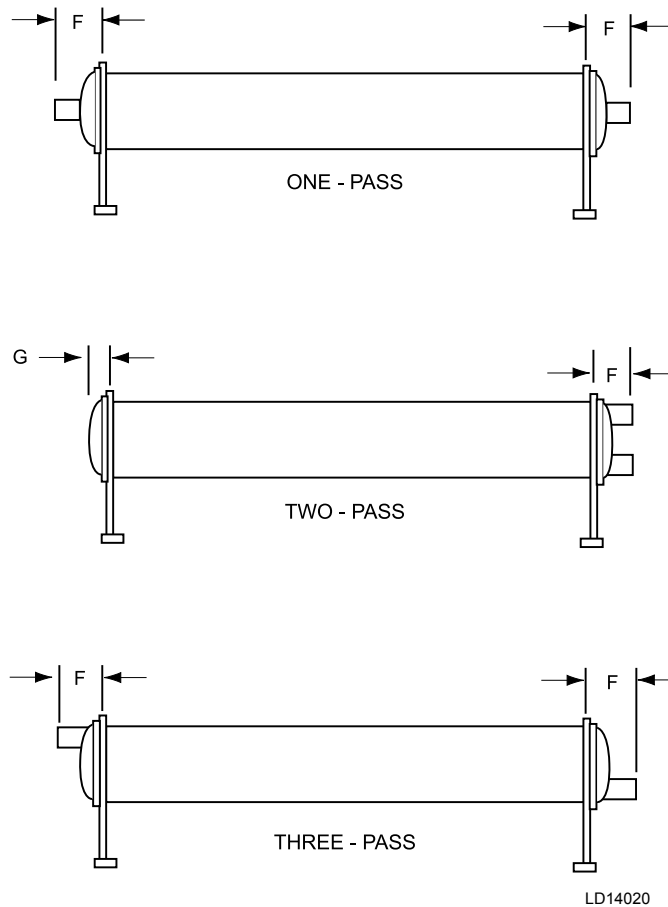
EVAPORATOR 150 & 300 PSI COMPACT WATER BOXES DIMENSIONS

COMPACT WATER BOXES DIMENSIONS FT - IN (MM)				
EVAPORATOR SHELL CODE	150 PSI		300 PSI	
	F	G	F	G
EB25	1'-4-1/8" (410)	0'-6-7/16" (164)	1'-6-1/16" (459)	0'-8-3/16" (208)
EB29	1'-4-13/16" (427)	0'-6-31/32" (177)	1'-7-3/16" (487)	0'-9-7/32" (234)
EB33	1'-5-3/8" (441)	0'-7-1/2" (191)	1'-6-1/4" (464)	0'-9-1/2" (241)

NOTES:

- All dimensions shown in Ft/In (mm)
- Standard water nozzles are furnished as welding stub-outs with ANSI/AWWA C-606 grooves, allowing the option of welding, flanges, or use of ANSI/AWWA C-606 couplings. Factory-installed, class 150 (ANSI B16.5, round slip-on, forged carbon steel with 1.6mm raised face), water flanged nozzles are optional (add 13mm to nozzle length). Companion flanges, nuts, bolts, and gaskets are not furnished.
- One-, Two- and Three-pass nozzle arrangements are available only in pairs shown and for all shell codes. Any pair of evaporator nozzles may be used in combination with any pair of condenser nozzles.
- Evaporator and condenser water must enter the water box through the bottom connection to achieve rated performance.
- Connected piping should allow for removal of compact water boxes for tube access and cleaning.
- Add dimension "M" as shown on the unit dimensions page for the appropriate isolator type.

FIGURE 48 - EVAPORATOR - 150 & 300 PSI COMPACT WATER BOXES

CONDENSER 150 & 300 PSI COMPACT WATER BOXES

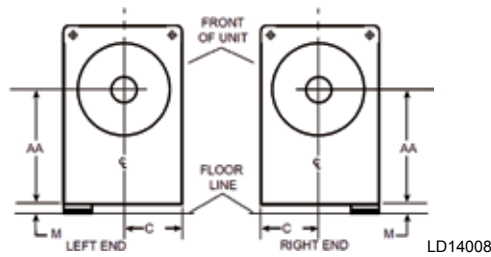

1-Pass Condenser Nozzle Arrangements	
In	Out
Left End	Right End
Right End	Left End

FIGURE 49 - CONDENSER - COMPACT WATER BOXES (1-PASS NOZZLE ARRANGEMENTS)

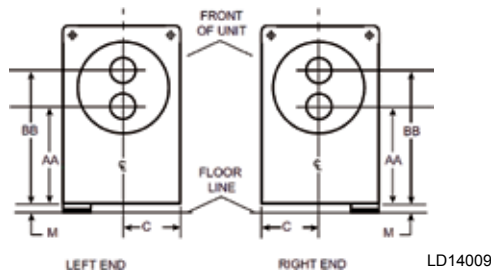

2-Pass Condenser Nozzle Arrangements	
In	Out
Lower Right End	Upper Right End
Lower Left End	Upper Left End

FIGURE 50 - CONDENSER - COMPACT WATER BOXES (3-PASS NOZZLE ARRANGEMENTS)

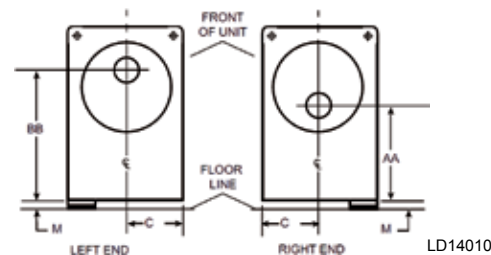

3-Pass Condenser Nozzle Arrangements	
In	Out
Right End	Left End

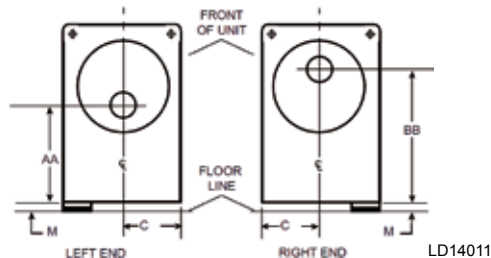

3-Pass Condenser Nozzle Arrangements	
In	Out
Left End	Right End

FIGURE 51 - CONDENSER - COMPACT WATER BOXES (2-PASS NOZZLE ARRANGEMENTS)

COMPACT WATER BOXES -150 & 300 PSI DIMENSIONS									
Condenser Shell Code	Nozzle Pipe Size In (mm)			Condenser Nozzle Dimensions Ft-In (mm)					
	No. of Passes			C	1-Pass	2-Pass		3-Pass	
	1	2	3		AA	AA	BB	AA	BB
CB21	10" (254)	6" (152)	6" (152)	1'-4" (406)	2'-2-3/8" (670)	1'-7-7/8" (505)	2'-8-7/8" (835)	1'-7-7/8" (505)	2'-8-7/8" (835)
CB25	12" (305)	8" (203)	6" (152)	1'-4" (406)	1'-10" (559)	1'-2-3/8" (365)	2'-5-5/8" (752)	1'-2-3/8" (365)	2'-5-5/8" (752)
CB29 (150 PSI)	14" (356)	10" (254)	8" (203)	1'-4" (406)	1'-10" (559)	1'-1-3/4" (349)	2'-6-1/4" (768)	1'-1-3/4" (349)	2'-6-1/4" (768)
	14" (356)	10" (254)	8" (203)	1'-5-1/2" (445)	2'-0" (610)	1'-3-3/4" (400)	2'-8-1/4" (819)	1'-3-3/4" (400)	2'-8-1/4" (819)
CB29 (300 PSI)	14" (356)	10" (254)	8" (203)	1'-4" (406)	1'-10" (559)	1'-1" (330)	2'-7" (787)	1'-1" (330)	2'-7" (787)
	14" (356)	10" (254)	8" (203)	1'-5-1/2" (445)	2'-0" (610)	1'-3" (381)	2'-9" (838)	1'-3" (381)	2'-9" (838)
CB33	16" (406)	10" (254)	10" (254)	1'-5-1/2" (445)	2'-0" (610)	1'-3" (381)	2'-9" (838)	1'-3" (381)	2'-9" (838)
CB33	16" (406)	10" (254)	10" (254)	1'-8" (508)	2'-1" (635)	1'-4" (406)	2'-10" (864)	1'-4" (406)	2'-10" (864)

NOTE: Dimensions are shown in Inches (mm)

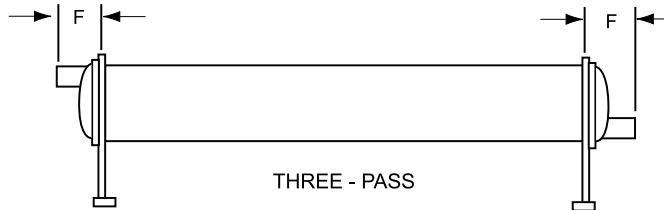
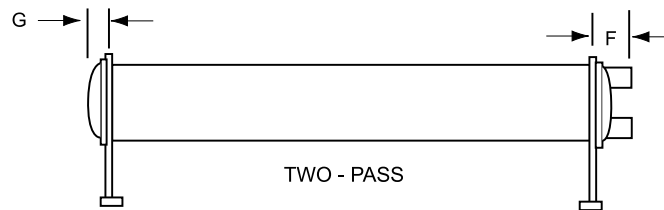
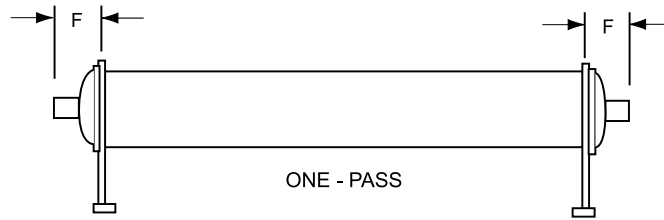
CONDENSER 150 & 300 PSI COMPACT WATER BOXES DIMENSIONS

LD14020

COMPACT WATER BOXES DIMENSIONS FT - IN (MM)									
Condenser Shell Code	150 PSI		300 PSI						
	F	G	F NO 6	F NO 8	F NO 10	F NO 12	F NO 14	F NO 16	G
CB21	1'-3-3/4" (400)	5-29/32" (150)	1'-6-19/32" (472)	-	1'-6-21/32" (474)	-	-	-	0'-6-17/32" (166)
CB25	1'-3-3/4" (400)	0'-6-7/16" (164)	1'-7-23/32" (501)	1'-7-25/32" (502)	-	1'-7-25/32" (502)	-	-	0'-7-7/16" (189)
CB29	1'-4-7/8" (429)	6-31/32" (177)	-	1'-7-1/2" (495)	1'-7-1/2" (495)	-	1'-7-1/2" (495)	-	0'-8-15/32" (215)
CB33	1-5-3/8" (441)	0'-7-1/2" (191)	-	-	1'-8-1/4" (514)	-	-	1'-8-1/4" (514)	0'-8-3/4" (222)

NOTES:

- All dimensions shown in Ft/In (mm)
- Standard water nozzles are furnished as welding stub-outs with ANSI/AWWA C-606 grooves, allowing the option of welding, flanges, or use of ANSI/AWWA C-606 couplings. Factory-installed, class 150 (ANSI B16.5, round slip-on, forged carbon steel with 1.6 mm raised face), water flanged nozzles are optional (add 13 mm to nozzle length). Companion flanges, nuts, bolts, and gaskets are not furnished.
- One-, Two- and Three-pass nozzle arrangements are available only in pairs shown and for all shell codes. Any pair of evaporator nozzles may be used in combination with any pair of condenser nozzles.
- Evaporator and condenser water must enter the water box through the bottom connection to achieve rated performance.
- Connected piping should allow for removal of compact water boxes for tube access and cleaning.
- Add dimension "M" as shown on the unit dimensions page for the appropriate isolator type.

FIGURE 52 - CONDENSER - 150 & 300 PSI COMPACT WATER BOXES

EVAPORATOR 150 & 300 PSI MARINE WATER BOXES

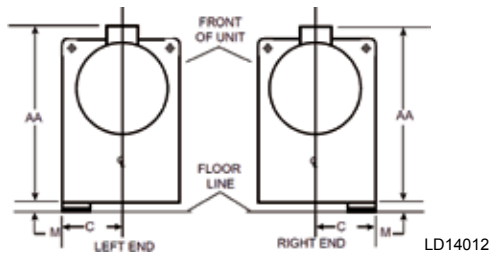

1-Pass Evaporator Nozzle Arrangements	
In	Out
Left End	Right End
Right End	Left End

FIGURE 53 - EVAPORATOR - MARINE WATER BOXES (1-PASS NOZZLE ARRANGEMENTS)

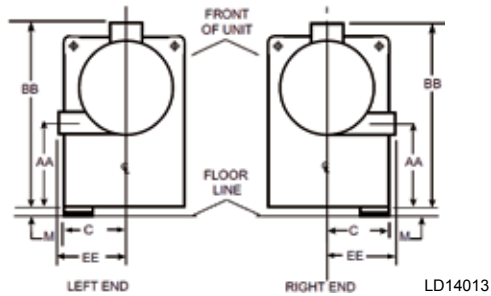

2-Pass Evaporator Nozzle Arrangements	
In	Out
Lower Right End	Upper Right End
Lower Left End	Upper Left End

FIGURE 54 - EVAPORATOR - MARINE WATER BOXES (2-PASS NOZZLE ARRANGEMENTS)

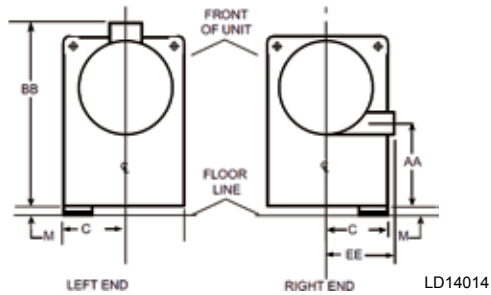

3-Pass Evaporator Nozzle Arrangements	
In	Out
Right End	Left End

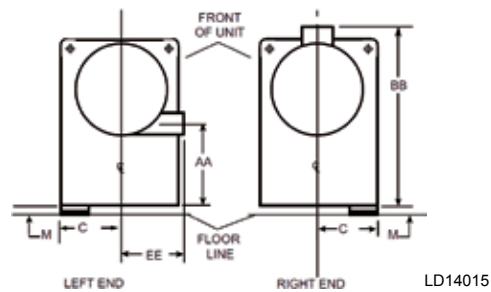

3-Pass Evaporator Nozzle Arrangements	
In	Out
Left End	Right End

FIGURE 55 - EVAPORATOR - MARINE WATER BOXES (3-PASS NOZZLE ARRANGEMENTS)

MARINE WATER BOXES -150 PSI													
EVAPORATOR SHELL CODE	NOZZLE PIPE SIZE FT-IN (MM)			EVAPORATOR NOZZLE DIMENSIONS FT-IN (MM)									
	NO. OF PASSES			C	1-PASS	2-PASS			3-PASS				
	1	2	3		AA	AA	BB	EE	EE FLANG	AA	BB	EE	EE FLANG
EB25	8	6	4	1'-4-5/8" (422)	3'-11" (1194)	0'-9" (229)	3'-11" (1194)	1'-5-1/2" (445)	1'-6" (457)	0'-9" (229)	3'-11" (1194)	1'-4" (406)	1'-4-1/2" (419)
EB29	10	8	6	1'-5-1/2" (445)	4'-3" (1295)	0'-10" (254)	4'-3" (1295)	1'-6-1/2" (470)	1'-7" (483)	0'-10" (254)	4'-3" (1295)	1'-6-1/2" (470)	1'-7" (483)
EB33	14	10	8	1'-7-1/2" (495)	4'-7" (1397)	0'-44" (279)	4'-7" (1397)	1'-9-1/2" (546)	1'-10" (559)	0'-11" (279)	4'-7" (1397)	1'-9-1/2" (546)	1'-10" (559)

NOTE: Dimensions are shown in Inches (mm)

See Figure 21 on page 32, Figure 22 on page 33 and Figure 23 on page 34.

MARINE WATER BOXES -300 PSI												
EVAPORATOR SHELL CODE	NOZZLE PIPE SIZE FT-IN (MM)			EVAPORATOR NOZZLE DIMENSIONS FT-IN (MM)								
	NO. OF PASSES			C	1-PASS	2-PASS			3-PASS			
	1	2	3		AA	AA	BB	EE	AA	BB	EE	
EB25	8	6	4	1'-4-5/8" (422)	3'-11" (1194)	0'-9" (229)	3'-11" (1194)	1'-6" (457)	0'-9" (229)	3'-11" (1194)	1'-4-1/2" (419)	
EB29	10	8	6	1'-5-1/2" (445)	4'-3" (1295)	0'-10" (254)	4'-3" (1295)	1'-7-3/8" (492)	0'-10" (254)	4'-3" (1295)	1'-7-3/8" (492)	
EB33	14	10	8	1'-7-1/2" (495)	4'-7" (1397)	0'-11" (279)	4'-7" (1397)	1'-10-5/8" (575)	0'-11" (279)	4'-7" (1397)	1'-10-5/8" (575)	

NOTE: Dimensions are shown in Inches (mm)

See Figure 21 on page 32, Figure 22 on page 33 and Figure 23 on page 34.

EVAPORATOR 150 & 300 PSI MARINE WATER BOXES DIMENSIONS

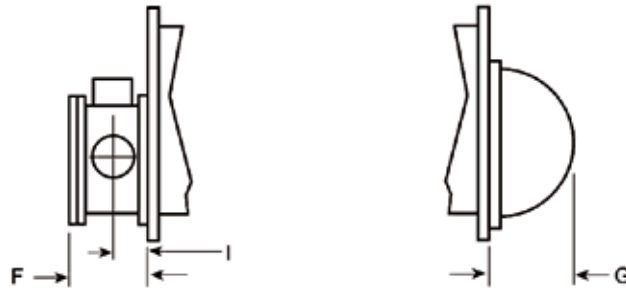

LD14021

MARINE WATER BOXES DIMENSIONS 150 PSI, FT - IN (MM)							
EVAPORATOR SHELL CODE	1-PASS		2-PASS			3-PASS	
	F	I	F	I	G	F	I
EB25	1'-5-5/8" (448)	0'-8-13/16" (224)	1'-3-1/2" (394)	0'-7-3/4" (197)	0'-6-7/16" (164)	1'-3-1/2" (394)	0'-7-3/4" (197)
EB29	1'-9-1/4" (540)	0'-10-5/8" (270)	1'-7-1/8" (486)	0'-9-9/16" (243)	0'-6-31/32" (177)	1'-7-1/8" (486)	0'-9-9/16" (243)
EB33	2'-0-1/4" (616)	1'-0-1/8" (308)	1'-8-1/2" (521)	0'-10-1/4" (260)	0'-7-1/2" (191)	1'-8-1/2" (521)	0'-10-1/4" (260)

MARINE WATER BOXES DIMENSIONS 300 PSI, FT - IN (MM)							
EVAPORATOR SHELL CODE	1-PASS		2-PASS			3-PASS	
	F	I	F	I	G	F	I
EB25	1'-6-1/8" (460)	0'-9-1/16" (230)	1'-4-1/8" (410)	0'-8-1/16" (205)	0'-8-3/16" (208)	1'-4-1/8" (410)	0'-8-1/16" (205)
EB29	1'-9-1/4" (540)	0'-10-5/8" (270)	1'-7-1/8" (486)	0'-9-9/16" (243)	0'-9-7/32" (234)	1'-7-1/8" (486)	0'-9-9/16" (243)
EB33	2'-0-1/4" (616)	1'-0-1/8" (308)	1'-8-1/2" (521)	0'-10-1/4" (260)	0'-9-1/2" (241)	1'-8-1/2" (521)	0'-10-1/4" (260)

NOTES:

- All dimensions shown in Ft/In (mm)
- All dimensions are approximate. Certified dimensions are available upon request.
- Standard water nozzles are Schedule 40 pipe size, furnished as welding stub-outs with ANSI/AWWA C-606 grooves, allowing the option of welding, flanges, or use of ANSI/AWWA C-606 couplings. Factory-installed, class 150 (ANSI B16.5, round slip-on, forged carbon steel with 1.6 mm raised face), water flanged nozzles are optional (add 13 mm to nozzle length). Companion flanges, nuts, bolts, and gaskets are not furnished.
- One-, two-, and three-pass nozzle arrangements are available only in pairs shown and for all shell codes. Any pair of evaporator nozzles may be used in combination with any pair of condenser nozzles. Compact water boxes on one heat exchanger may be used with Marine Water Boxes on the other heat exchanger.
- Water must enter the water box through the bottom connection to achieve rated performance.

FIGURE 56 - EVAPORATOR - 150 AND 300 PSI MARINE WATER BOXES

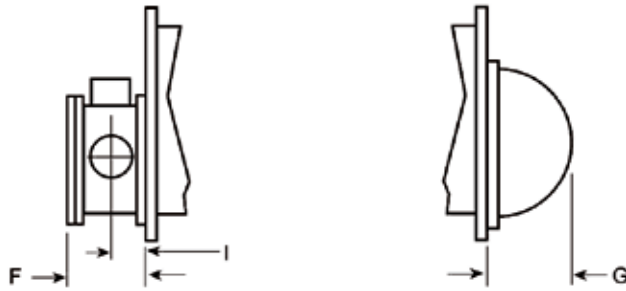
CONDENSER 150 & 300 PSI MARINE WATER BOXES DIMENSIONS

LD14021

MARINE WATER BOXES DIMENSIONS 150 PSI, FT - IN (MM)							
CONDENSER SHELL CODE	1-PASS		2-PASS			3-PASS	
	F	I	F	I	G	F	I
CB21	1'-7-3/4" (502)	0'-9-7/8" (251)	1'-3-5/8" (397)	0'-7-13/16" (198)	0'-5-5/32" (131)	1'-3-5/8" (397)	0'-7-13/16" (198)
CB25	1'-10-1/4" (565)	0'-11-1/8" (283)	1'-6-1/8" (460)	0'-9-1/16" (230)	0'-5-11/32" (144)	1'-6-1/8" (460)	0'-9-1/16" (230)
CB29	1'-11" (584)	0'-11-1/2" (292)	1'-7-3/4" (502)	0'-9-7/8" (251)	0'-6-7/32" (158)	1'-7-3/4" (502)	0'-9-7/8" (251)
CB33	2'-1" (635)	1'-1/2" (318)	1'-7-3/4" (502)	0'-9-7/8" (251)	0'-6-3/4" (171)	1'-7-3/4" (502)	0'-9-7/8" (251)

MARINE WATER BOXES DIMENSIONS 300 PSI, FT - IN (MM)							
CONDENSER SHELL CODE	1-PASS		2-PASS			3-PASS	
	F	I	F	I	G	F	I
CB21	1'-9-13/16" (554)	0'-10-29/32" (277)	1'-5-11/16" (449)	0'-8-27/32" (225)	0'-5-29/32" (150)	1'-5-11/16" (449)	0'-8-27/32" (225)
CB25	2'-0-1/2" (622)	1'-0-1/4" (311)	1'-8-3/8" (518)	0'-10-3/16" (259)	0'-6-7/16" (164)	1'-8-3/8" (518)	0'-10-3/16" (259)
CB29	2'-0-1/2" (622)	1'-0-1/4" (311)	1'-9-1/4" (540)	0'-10-5/8" (270)	0'-6-31/32" (177)	1'-9-1/4" (540)	0'-10-5/8" (270)
CB33	2'-1-3/4" (654)	1'-0-7/8" (327)	1'-8-1/2" (521)	0'-10-1/4" (260)	0'-7-1/2" (191)	1'-8-1/2" (521)	0'-10-1/4" (260)

NOTES:

- All dimensions shown in Ft/In (mm)
- All dimensions are approximate. Certified dimensions are available upon request.
- Standard water nozzles are Schedule 40 pipe size, furnished as welding stub-outs with ANSI/AWWA C-606 grooves, allowing the option of welding, flanges, or use of ANSI/AWWA C-606 couplings. Factory-installed, class 150 (ANSI B16.5, round slip-on, forged carbon steel with 1.6 mm raised face), water flanged nozzles are optional (add 13 mm to nozzle length). Companion flanges, nuts, bolts, and gaskets are not furnished.
- One-, two-, and three-pass nozzle arrangements are available only in pairs shown and for all shell codes. Any pair of evaporator nozzles may be used in combination with any pair of condenser nozzles. Compact water boxes on one heat exchanger may be used with Marine Water Boxes on the other heat exchanger.
- Condenser water must enter the water box through the bottom connection for proper operation of the sub-cooler to achieve rated performance. Add dimension "M" as shown on pages per unit dimensions page for the appropriate isolator type.

FIGURE 57 - CONDENSER - 150 AND 300 PSI MARINE WATER BOXES

CONDENSER 150 PSI MARINE WATER BOXES

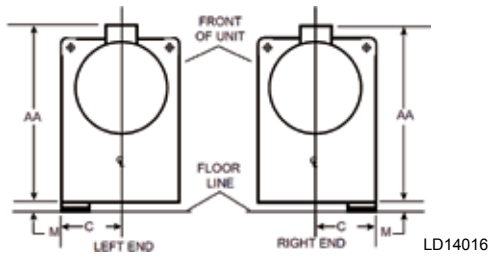

1-Pass Condenser Nozzle Arrangements	
In	Out
Left End	Right End
Right End	Left End

FIGURE 58 - CONDENSER - MARINE WATER BOXES (1-PASS NOZZLE ARRANGEMENTS)

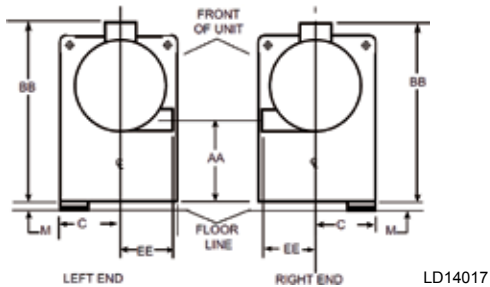

2-Pass Condenser Nozzle Arrangements	
In	Out
Lower Right End	Upper Right End
Lower Left End	Upper Left End

FIGURE 59 - CONDENSER - MARINE WATER BOXES (2-PASS NOZZLE ARRANGEMENTS)

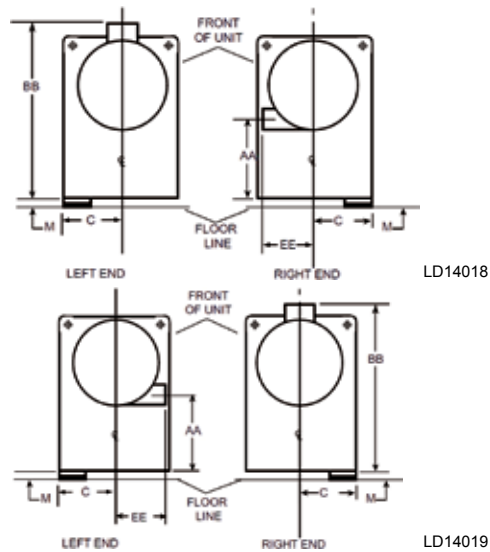

3-Pass Condenser Nozzle Arrangements	
In	Out
Right End	Left End

3-Pass Condenser Nozzle Arrangements	
In	Out
Left End	Right End

FIGURE 60 - CONDENSER - MARINE WATER BOXES (3-PASS NOZZLE ARRANGEMENTS)

CONDENSER 150 & 300 PSI MARINE WATER BOXES DIMENSIONS

MARINE WATER BOXES -150 & 300 PSI													
CONDENSER SHELL CODE	NOZZLE PIPE SIZE FT - IN (MM)			EVAPORATOR NOZZLE DIMENSIONS FT - IN (MM)									
	NO. OF PASSES			C	1-PASS		2-PASS			EE FLANGE	3-PASS		
	1	2	3		AA	AA	BB	EE	AA		BB	EE	EE FLANGE
CB21	10" (254)	6" (152)	6" (152)	1'-4" (406)	4'-3-3/8" (1305)	1'-6-3/8" (467)	4'-3-3/8" (1305)	1'-4-1/2" (419)	1'-5-1/2" (445)	1'-6-3/8" (467)	4'-3-3/8" (1305)	1'-4-1/2" (419)	1'-5-1/2" (445)
CB25	12" (305)	8" (203)	6" (152)	1'-4" (406)	4'-1" (1245)	1'-0-1/8" (308)	4'-1" (1245)	1'-6-1/2" (470)	1'-7-3/8" (492)	1'-0-1/8" (308)	4'-1" (1245)	1'-6-1/2" (470)	1'-7-3/8" (492)
CB29	14" (356)	10" (254)	8" (203)	1'-4" (406)	4'-3" (1295)	1'-0" (305)	4'-3" (1295)	1'-9" (533)	1'-10-1/8" (562)	1'-0" (305)	4'-3" (1295)	1'-9" (533)	1'-10-1/8" (562)
	14" (356)	10" (254)	8" (203)	1'-5-1/2" (445)	4'-5" (1346)	1'-2" (356)	4'-5" (1346)	1'-9" (533)	1'-10-1/8" (562)	1'-2" (356)	4'-5" (1346)	1'-9" (533)	1'-10-1/8" (562)
CB33	16" (406)	10" (254)	10" (254)	1'-5-1/2" (445)	4'-7" (1397)	0'-9" (229)	4'-7" (1397)	1'-9-1/2" (546)	1'-10-5/8" (575)	0'-9" (229)	4'-7" (1397)	1'-9-1/2" (546)	1'-10-5/8" (575)
	16" (406)	10" (254)	10" (254)	1'-8" (508)	4'-8" (1422)	0'-10" (254)	4'-8" (1422)	1'-9-1/2" (546)	1'-10-5/8" (575)	0'-10" (254)	4'-8" (1422)	1'-9-1/2" (546)	1'-10-5/8" (575)

NOTE: Dimensions are shown in Inches (mm)

WEIGHTS**TABLE 15 - APPROXIMATE EVAPORATOR WEIGHTS 150 PSI COMPACT WATER BOXES***

EVAPORATOR		COMPACT WATER BOX WEIGHT LBS (KG)			MARINE WATER BOX WEIGHT LBS (KG)		
CODE	WEIGHT LBS (KG)	1-PASS	2-PASS	3-PASS	1-PASS	2-PASS	3-PASS
EB2510	3628 (1646)	264 (120)	269 (122)	272 (123)	474 (215)	563 (255)	514 (233)
EB2514	4545 (2062)	264 (120)	269 (122)	272 (123)	474 (215)	563 (255)	514 (233)
EB2910	4338 (1968)	332 (151)	355 (161)	360 (163)	624 (283)	731 (332)	688 (312)
EB2914	5502 (2496)	332 (151)	355 (161)	360 (163)	624 (283)	731 (332)	688 (312)
EB3310	5372 (2437)	402 (182)	421 (191)	432 (196)	776 (352)	851 (386)	826 (375)
EB3314	6779 (3075)	402 (182)	421 (191)	432 (196)	776 (352)	851 (386)	826 (375)

Weights based on maximum tube bundle allowed per shell.

TABLE 16 - APPROXIMATE CONDENSER WEIGHTS 150 PSI COMPACT WATER BOXES*

CONDENSER		COMPACT WATER BOX WEIGHT LBS (KG)			MARINE WATER BOX WEIGHT LBS (KG)		
CODE	WEIGHT LBS (KG)	1-PASS	2-PASS	3-PASS	1-PASS	2-PASS	3-PASS
CB2110	1925 (873)	230 (104)	219 (99)	230 (104)	464 (210)	457 (207)	444 (201)
CB2510	3309 (1501)	282 (128)	281 (127)	284 (129)	588 (267)	606 (275)	574 (260)
CB2514	4532 (2056)	282 (128)	281 (127)	284 (129)	588 (267)	606 (275)	574 (260)
CB2910	4258 (1931)	340 (154)	354 (161)	354 (161)	688 (312)	752 (341)	710 (322)
CB2914	5854 (2655)	340 (154)	354 (161)	354 (161)	688 (312)	752 (341)	710 (322)
CB3310	5343 (2424)	406 (184)	419 (190)	444 (201)	816 (370)	851 (386)	814 (369)
CB3314	7362 (3339)	406 (184)	419 (190)	444 (201)	816 (370)	851 (386)	814 (369)

Weights based on maximum tube bundle allowed per shell.

WEIGHTS (CONT'D)

TABLE 17 - APPROXIMATE VARIABLE SPEED DRIVE (VSD) WEIGHTS

VSD	WEIGHT LBS (KG)
HYP490XH30B-46	1226 (556)
HYP744XH30B-46	2075 (941)
HYP774XH30B-46	2060 (934)

TABLE 18 - APPROXIMATE DRIVELINE WEIGHTS

COMPRESSOR	WEIGHT LBS (KG)
M2C-197FAC	2872 (1303)
M2C-205FAC	2879 (1306)
M2C-218FAC	2998 (1360)
M2C-233FAC	3011 (1366)
M2C-246FAC	3009 (1365)
M6C-331FAC	4500 (2041)

TABLE 19 - APPROXIMATE REFRIGERANT & WATER WEIGHT

EVAPORATOR	CONDENSER	REFRIGERANT WEIGHT LBS (KG)*	WATER WEIGHT LBS (KG)**
EB2510	CB2110	540 (250)	980 (450)
	CB2510	600 (270)	1310 (600)
EB2514	CB2514	840 (380)	1680 (770)
EB2910	CB2510	640 (290)	1510 (690)
	CB2910	860 (390)	1760 (800)
EB2914	CB2514	900 (410)	1940 (880)
	CB2914	1210 (550)	2240 (1020)
EB3310	CB2910	920 (420)	2070 (940)
	CB3310	980 (450)	2580 (1170)
EB3314	CB2914	1290 (590)	2640 (1200)
	CB3314	1380 (630)	3310 (1510)

*Refrigerant Weight based on maximum tube bundle.

** Water Weight is the total water in both shells and for 150PSI, 2-pass, compact water boxes.

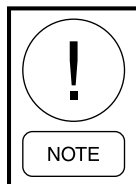

Refer to product submittal drawings for detailed weight information specific to the unit ordered.



P.O. Box 1592, York, Pennsylvania USA 17405-1592
Copyright © by Johnson Controls 2013
Form 160.84-N1 (913)
Issue Date: September 30, 2013
Supersedes: August 30, 2013

800-861-1001
www.johnsoncontrols.com

Subject to change without notice. Printed in USA
ALL RIGHTS RESERVED