



Service Information

File In/With: XXXX

SI0391

New 618

Equipment Affected: YLAA, YLUA and YCAL
Air-Cooled Chillers

Retrofit instructions for replacing a VFD66 condenser fan drive with the ABB ACS250 condenser fan drive

The VFD66 condenser fan drives are no longer available. The ABB ACS250 drive in a NEMA 4X enclosure will replace the obsoleted VFD66 drive. The following chiller models are affected:

- YLAA and YLUA models (with Low Ambient Drives)
NOTE: Only Available on systems with 2 or 3 fans per circuit.
Not Available for systems with 4 fans or more per circuit.
- YCAL0028-0033 (single circuit)
- YCAL0043-0066 (dual circuit)

This service information letter will provide the ordering and installation instructions needed to replace the drive.

ORDERING THE REPLACEMENT DRIVE

Below are the drive/bracket part numbers for the drives that replace the VFD66. These parts are available through Baltimore Parts Center.

230V drive
025-47497-003

460V drive
025-47497-013

575V drive
025-47497-130

New mounting brackets are required for this retrofit. The bracket will mount in the same place as the current drives.

- YLAA and YLUA: **075-55889-061** (Bracket)
- YCAL0028-0033: **075-55889-064** (Bracket)
- YCAL0043-0066: **075-55889-062** (Support) & **075-55889-063** (Bracket)

Work on this equipment should only be done by properly trained personnel who are qualified to work on this type of equipment. Failure to comply with this requirement could expose the worker, the equipment and the building and its inhabitants to the risk of injury or property damage.

The instructions on this service bulletin are written assuming the individual who will perform this work is a fully trained HVAC & R journeyman or equivalent, certified in refrigerant handling and recovery techniques, and knowledgeable with regard to electrical lock out/tag out procedures. The individual performing this work should be aware of and comply with all Johnson Controls, national, state and local safety and environmental regulations while carrying out this work. Before attempting to work on any equipment, the individual should be thoroughly familiar with the equipment by reading and understanding the associated service literature applicable to the equipment. If you do not have this literature, you may obtain it by contacting a Johnson Controls Service Office.

Should there be any question concerning any aspect of the tasks outlined in this bulletin, please consult a Johnson Controls Service Office prior to attempting the work. Please be aware that this information may be time sensitive and that Johnson Controls reserves the right to revise this information at any time. Be certain you are working with the latest information.

Product Technical Support

Retrofit Procedure Summary

1. Lockout/Tagout the chiller according to proper electrical safety requirements.
2. Disconnect the VFD66 drive from the chiller.
3. Install the new brackets (and the new support for the YCAL0043-0066 models)
4. Mount the new ACS250 drive onto the bracket.
5. Wire the chiller according to the appropriate chiller wiring diagram.
6. Remove the Lock/Tag from the chiller and apply power to the chiller.
7. Follow the instructions in the ACS250 manual and the following pages to power and set up the drive parameters.

YLAA AND YLUA: 075-55889-061 (BRACKET)

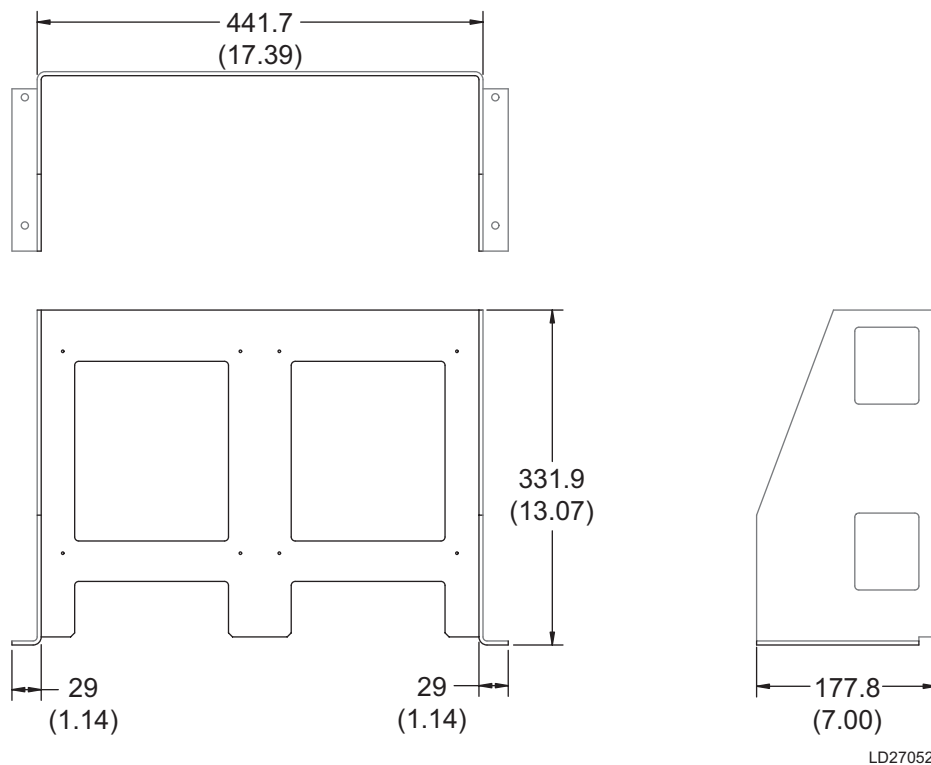

FOR YCAL0028-0033: 075-55889-064

(Single Circuit)



LD27053

YCAL0043-0066: 075-55889-062 (SUPPORT) & 075-55889-063 (BRACKET)

YCAL (Dual Circuit)

YLAA / YLUA (Dual Circuit)



LD27054

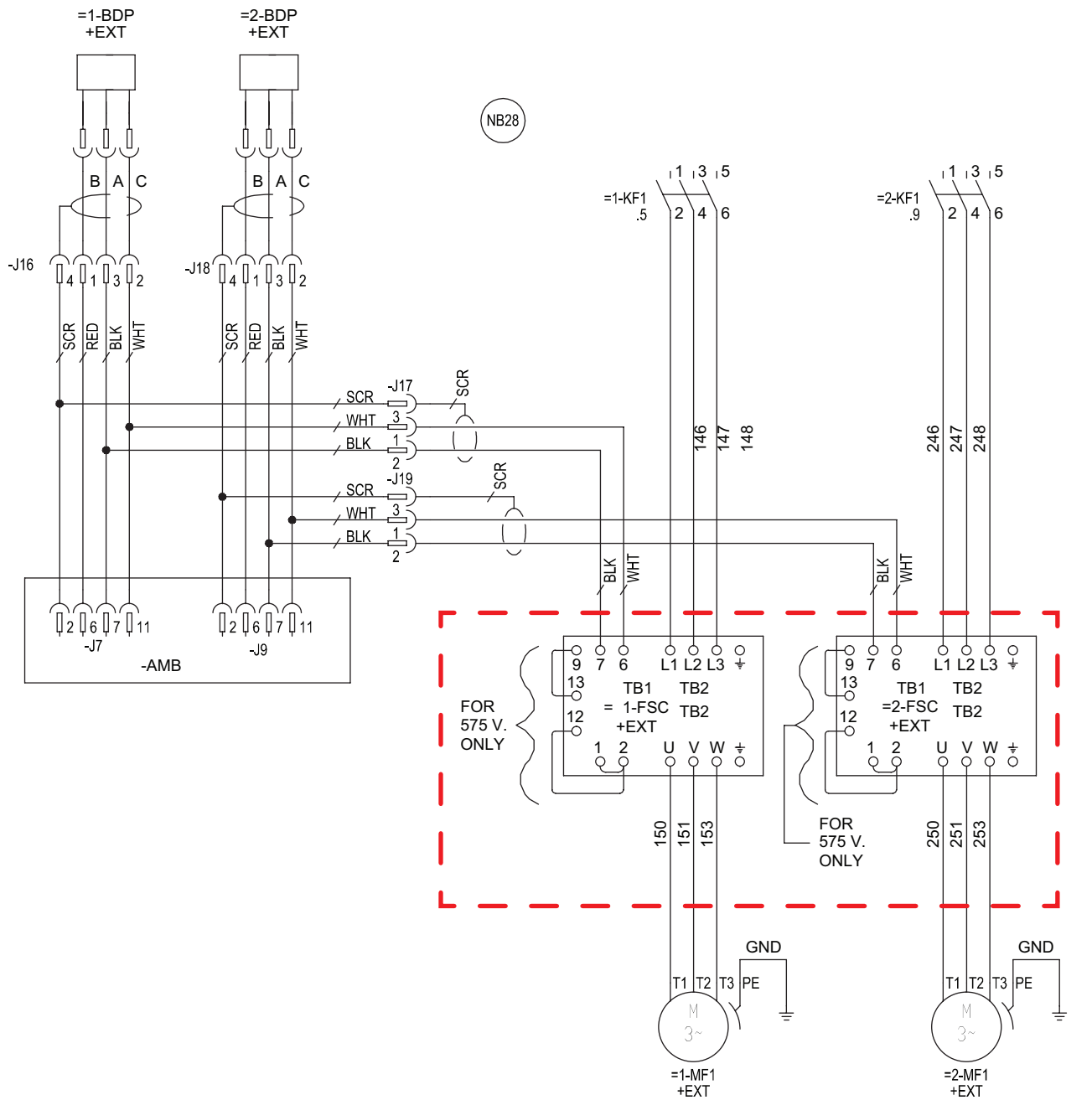

LD27051

FIGURE 1 - YLAA AND YLUA ACS 250 DRIVE WIRING

ELEMENTARY DIAGRAM

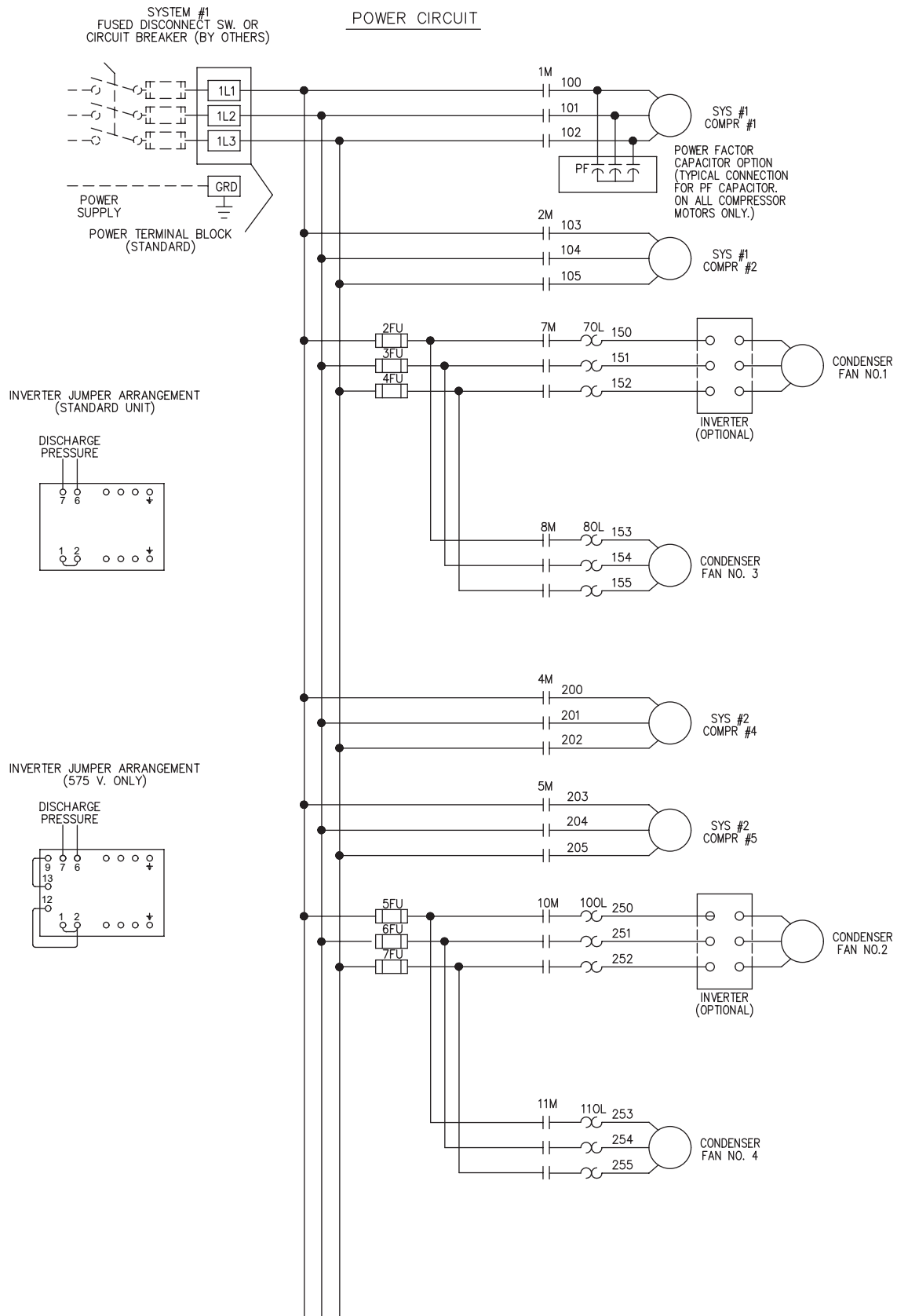

LD27050

FIGURE 2 - YCAL ACS DRIVE WIRING

Drive Programming Instructions (Instructions to access Service Mode are also located on the chiller control panel)

1. To enable Service Mode, set the unit rocker switch to OFF.
2. Press the Program Key.
3. Press Up Arrow twice and then Down Arrow twice (↑↑↓↓).
4. Press Enter/Advance Key.
5. Press the Enter/Advance key until Liquid Line solenoid option is displayed.
6. Use the up/down arrow keys to enable Liquid Line solenoid output and press Enter/Advance key.
7. Turn On System 1 Fan Output 1. This will send voltage to the drive allowing the drive parameters to be adjusted.
8. Set up the drive as required (*See page 7*).

Setup of ABB ACS250 VSD for Low Ambient Kit

Refer to the ABB ACS250 manual for more detailed instructions on entering modes and making adjustments to drive. Ensure the drive is set for “Par L” to see all parameter code settings.

Parameter Structure

The parameters within the drive are split into 2 groups. Group 1 is titled “Short Parameter Mode” and is displayed as “PAR S” on the drive display. Group 2 is titled “Long Parameter Mode” and is displayed as “PAR L” on the drive display.

- “PAR S” group brings together the most commonly used parameters to aid in quick setup.
- “PAR L” group includes all of the drive parameters.

GROUP NAVIGATION

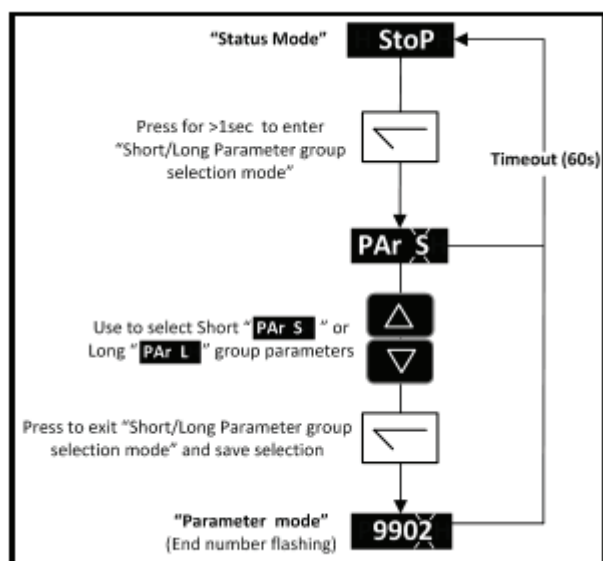

PARAMETER STRUCTURE

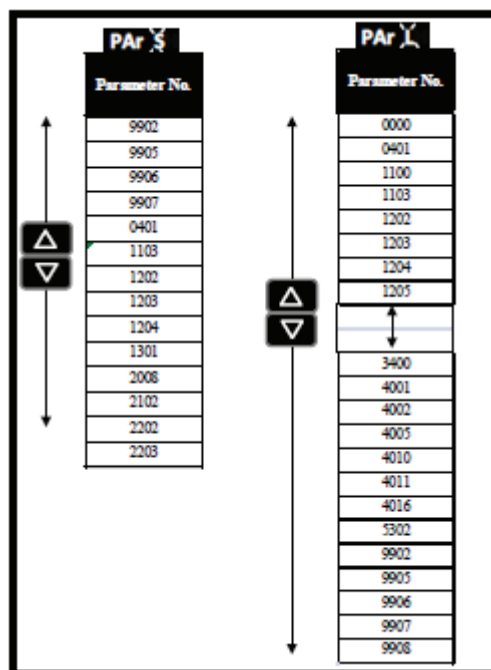

All other settings not listed below are to be left in their default values.

PARAMETER CODE	DESCRIPTION	SETTING
9902	Function Select	0
9905	Motor Rated Voltage	See motor nameplate (208V,230V,460V)
9906	Motor Rated Current	See motor nameplate
9907	Motor Frequency	See motor nameplate (50 Hz, 60 Hz)
1103	Command Source Mode	0
1300	Analog Input 1 Signal Format	U 0-10
1301	Analog Input 1 Offset	23.5
1302	Analog Input 1 Scaling	1850
2007	Min Frequency Limit	0
2008	Max Frequency Limit	See motor nameplate (50 Hz, 60 Hz)
2102	Stop Mode	0
2202	Accel Time	30.0
2203	Decel Time	30.0
2601	Energy Optimizer	0