



# AIR-COOLED SCROLL CHILLER

INSTALLATION, OPERATION, MAINTENANCE

Supersedes: 150.72-ICOM6 (817)

Form 150.72-ICOM6 (1217)

035-23572-100

## YLAA0058 - YLAA0230 AIR-COOLED SCROLL CHILLERS WITH BRAZED PLATE HEAT EXCHANGER STYLE B (60 HZ) 4-10 FAN 55 - 230 TON 195 - 700 KW

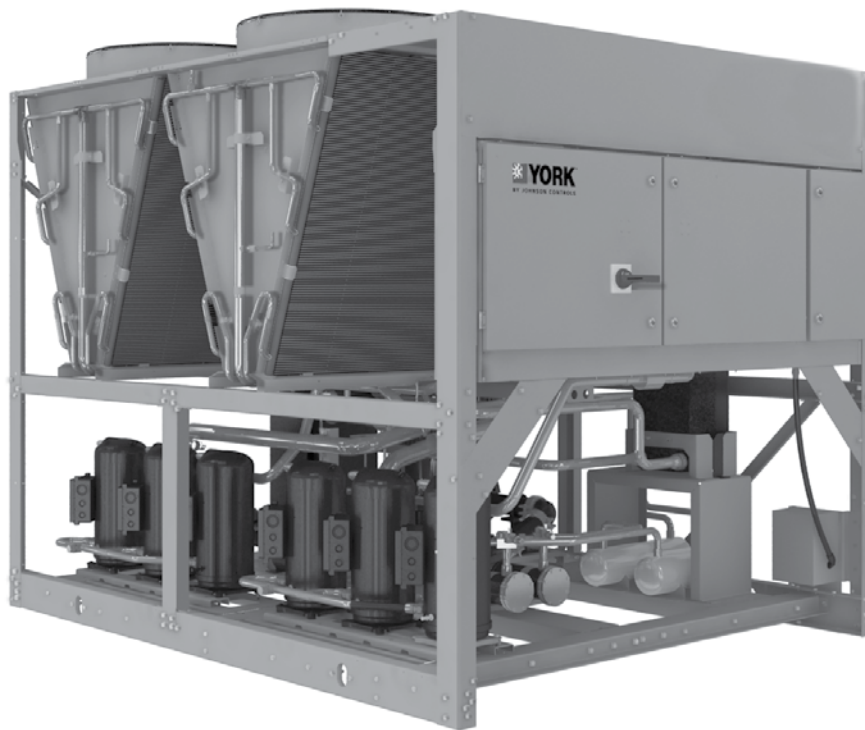

**R-410A**



Issue Date:  
December 29, 2017



# IMPORTANT!

## READ BEFORE PROCEEDING!

### GENERAL SAFETY GUIDELINES

This equipment is a relatively complicated apparatus. During rigging, installation, operation, maintenance, or service, individuals may be exposed to certain components or conditions including, but not limited to: heavy objects, refrigerants, materials under pressure, rotating components, and both high and low voltage. Each of these items has the potential, if misused or handled improperly, to cause bodily injury or death. It is the obligation and responsibility of rigging, installation, and operating/service personnel to identify and recognize these inherent hazards, protect themselves, and proceed safely in completing their tasks. Failure to comply with any of these requirements could result in serious damage to the equipment and the property in

which it is situated, as well as severe personal injury or death to themselves and people at the site.

This document is intended for use by owner-authorized rigging, installation, and operating/service personnel. It is expected that these individuals possess independent training that will enable them to perform their assigned tasks properly and safely. It is essential that, prior to performing any task on this equipment, this individual shall have read and understood the on-product labels, this document and any referenced materials. This individual shall also be familiar with and comply with all applicable industry and governmental standards and regulations pertaining to the task in question.

---

## SAFETY SYMBOLS

The following symbols are used in this document to alert the reader to specific situations:



*Indicates a possible hazardous situation which will result in death or serious injury if proper care is not taken.*



*Identifies a hazard which could lead to damage to the machine, damage to other equipment and/or environmental pollution if proper care is not taken or instructions and are not followed.*



*Indicates a potentially hazardous situation which will result in possible injuries or damage to equipment if proper care is not taken.*

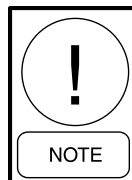

*Highlights additional information useful to the technician in completing the work being performed properly.*



*External wiring, unless specified as an optional connection in the manufacturer's product line, is not to be connected inside the control cabinet. Devices such as relays, switches, transducers and controls and any external wiring must not be installed inside the micro panel. All wiring must be in accordance with Johnson Controls' published specifications and must be performed only by a qualified electrician. Johnson Controls will NOT be responsible for damage/problems resulting from improper connections to the controls or application of improper control signals. Failure to follow this warning will void the manufacturer's warranty and cause serious damage to property or personal injury.*

## CHANGEABILITY OF THIS DOCUMENT

In complying with Johnson Controls' policy for continuous product improvement, the information contained in this document is subject to change without notice. Johnson Controls makes no commitment to update or provide current information automatically to the manual or product owner. Updated manuals, if applicable, can be obtained by contacting the nearest Johnson Controls Service office or accessing the Johnson Controls QuickLIT website at <http://cgproducts.johnsoncontrols.com>.

It is the responsibility of rigging, lifting, and operating/service personnel to verify the applicability of these documents to the equipment. If there is any question

regarding the applicability of these documents, rigging, lifting, and operating/service personnel should verify whether the equipment has been modified and if current literature is available from the owner of the equipment prior to performing any work on the chiller.

### CHANGE BARS

Revisions made to this document are indicated with a line along the left or right hand column in the area the revision was made. These revisions are to technical information and any other changes in spelling, grammar or formatting are not included.

---

## ASSOCIATED LITERATURE

Manual Description	Form Number
Start-Up Checklist - Style A and B, 60 Hz	150.72-CL1
Renewal Parts - YLAA0070-YLAA230 Style B 60 Hz	150.72-RP3
Limited Warranty Engineered Systems Equipment	50.05-NM2

# NOMENCLATURE

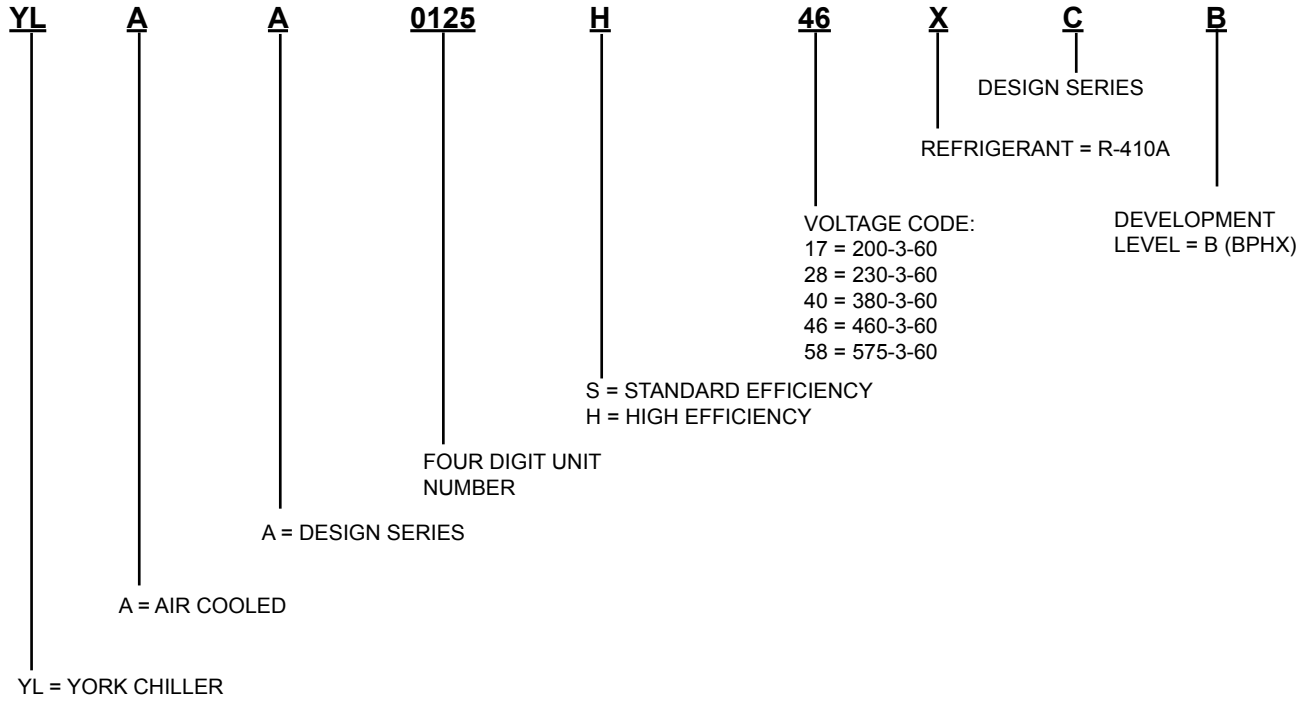

## TABLE OF CONTENTS

<b>SECTION 1 – GENERAL CHILLER INFORMATION AND SAFETY .....</b>	<b>11</b>
Introduction.....	11
Warranty.....	11
Handling .....	11
Safety and Quality .....	11
About this Manual.....	12
Misuse of Equipment.....	12
<b>SECTION 2 – PRODUCT DESCRIPTION .....</b>	<b>15</b>
Introduction.....	15
General System Description.....	15
Communications.....	17
Building Automation System Interface.....	17
Power Panel .....	17
Accessories and Options.....	18
<b>SECTION 3 – HANDLING AND STORAGE .....</b>	<b>31</b>
Delivery and Storage.....	31
Inspection .....	31
Moving the Chiller.....	31
Lifting Using Lugs.....	33
Lifting Using Shackles .....	33
Lifting Weights .....	34
<b>SECTION 4 – INSTALLATION.....</b>	<b>35</b>
Installation Checklist.....	35
Startup/Commissioning .....	35
Location and Clearances.....	35
Spring Isolators (Optional).....	36
Compressor Mounting .....	36
Remote Cooler Option.....	36
Chilled Liquid Piping.....	36
Pipework Arrangement .....	37
Wiring .....	37
Relief Valves.....	38
High Pressure Cutout.....	38
Single-Point Supply Connection – Terminal Block, Non-Fused Disconnect Switch or Circuit Breaker .....	39
<b>SECTION 5 – TECHNICAL DATA .....</b>	<b>43</b>
Physical Data YLAA0058 – YLAA0230 60Hz.....	46
Electrical Data .....	48
Compressor Heaters .....	48
Electrical Notes .....	56
Weight Distribution and Isolator Mounting Positions .....	87
Clearances .....	88
Isolator Locations .....	89
Isolator Information.....	92

## TABLE OF CONTENTS (CONT'D)

<b>SECTION 6 – COMMISSIONING.....</b>	<b>99</b>
Preparation – Power Off.....	99
Preparation – Power On.....	101
How to Commission the Pump VFD.....	102
<b>SECTION 7 – UNIT CONTROLS.....</b>	<b>107</b>
Introduction.....	107
IPU II and I/O Boards.....	107
Transformer.....	108
Display.....	108
Keypad.....	108
Unit Switch.....	108
Battery Back-Up.....	108
Programming # of Compressors.....	108
Status Key.....	109
Display/Print Keys.....	115
Entry Keys.....	123
Setpoints Keys.....	124
Schedule/Advance Day Key.....	125
Program Key.....	127
Unit Keys.....	131
Bacnet, Modbus, N2 and Yorktalk 2 Communications.....	137
<b>SECTION 8 – UNIT OPERATION.....</b>	<b>149</b>
Capacity Control.....	149
Suction Pressure Limit Controls.....	150
Discharge Pressure Limit Controls.....	150
Leaving Chilled Liquid Control.....	150
Leaving Chilled Liquid Control Override to Reduce Cycling.....	151
Leaving Chilled Liquid System Lead/Lag and Compressor Sequencing.....	152
Return Chilled Liquid Control.....	152
Return Chilled Liquid System Lead/Lag and Compressor Sequencing.....	153
Anti-Recycle Timer.....	153
Anti-Coincidence Timer.....	153
Evaporator Pump Control and York Hydro Kit Pump Control.....	153
Evaporator Heater Control.....	154
Pumpdown Control.....	154
Standard Condenser Fan Control.....	154
Load Limiting.....	158
Compressor Run Status.....	158
Alarm Status.....	158
Remote BAS/EMS Temperature Reset Using a Voltage or Current Signal.....	159

## TABLE OF CONTENTS (CONT'D)

<b>SECTION 9 – SERVICE AND TROUBLESHOOTING.....</b>	<b>161</b>
Clearing History Buffers.....	161
Service Mode .....	161
Service Mode – Outputs.....	161
Service Mode – Chiller Configuration.....	162
Service Mode – Analog and Digital Inputs.....	162
Control Inputs/Outputs .....	163
Checking Inputs and Outputs.....	165
Optional Printer Installation .....	168
Troubleshooting.....	170
<b>SECTION 10 – MAINTENANCE.....</b>	<b>173</b>
Compressors .....	173
Condenser Fan Motors.....	173
Condenser MCHX Cleaning.....	173
Operating Parameters .....	174
On-Board Battery Back-Up.....	174
Braze Plate Heat Exchanger (Evaporator) Heater .....	174
Overall Unit Inspection .....	174
Temperature .....	177

## LIST OF FIGURES

<b>FIGURE 1</b> - Unit Components (Front) .....	20
<b>FIGURE 2</b> - Unit Components (Side) .....	21
<b>FIGURE 3</b> - Power Panel Components .....	22
<b>FIGURE 4</b> - Power Panel / Control Components .....	23
<b>FIGURE 5</b> - Process and Instrumentation Diagram .....	29
<b>FIGURE 6</b> - Unit Rigging/Lifting .....	32
<b>FIGURE 7</b> - Warning .....	34
<b>FIGURE 8</b> - Chilled Liquid System .....	37
<b>FIGURE 9</b> - Single-Point Supply Connection – Terminal Block, Non-Fused Disconnect Switch or Circuit Breaker .....	39
<b>FIGURE 10</b> - Control Wiring Inputs .....	40
<b>FIGURE 11</b> - Thermal Dispersion Flow Switch.....	41
<b>FIGURE 12</b> - Thermal Dispersion Flow Switch (Combine Together).....	41
<b>FIGURE 13</b> - Control Wiring Outputs .....	42
<b>FIGURE 14</b> - Elementary Wiring Diagram.....	60
<b>FIGURE 15</b> - Elementary Wiring Diagram.....	62
<b>FIGURE 16</b> - Fan Wiring, Standard Air Flow .....	64
<b>FIGURE 17</b> - Fan Wiring, High Air Flow .....	66
<b>FIGURE 18</b> - Single and Dual Point Wiring Options.....	68
<b>FIGURE 19</b> - Pump Wiring .....	70
<b>FIGURE 20</b> - Compressor Wiring .....	72
<b>FIGURE 21</b> - Power Options Connection Diagram .....	74
<b>FIGURE 22</b> - Power Panel .....	76
<b>FIGURE 23</b> - Micro Panel Connections.....	78
<b>FIGURE 24</b> - Four Fan Units Dimensions – YLAA0058HE, YLAA0065HE, YLAA0081HE.....	80
<b>FIGURE 25</b> - Four Fan Units Dimensions – YLAA0070SE, YLAA0080SE, YLAA0089SE .....	81
<b>FIGURE 26</b> - Five Fan Units Dimensions – YLAA0100SE.....	82
<b>FIGURE 27</b> - Six Fan Units Dimensions – YLAA0120SE, YLAA0092HE, YLAA0101HE .....	83
<b>FIGURE 28</b> - Eight Fan Units Dimensions – YLAA0136SE, YLAA0155SE, YLAA0142HE .....	84
<b>FIGURE 29</b> - Ten Fan Units Dimensions – YLAA0170SE, YLAA0156HE, YLAA0175HE.....	85
<b>FIGURE 30</b> - Twelve Fan Units Dimensions .....	86
<b>FIGURE 31</b> - Sample Printout Supplied in the Isolator Package and in the Chiller Panel Literature Packet .....	87
<b>FIGURE 32</b> - Unit Clearances – All Models.....	88
<b>FIGURE 33</b> - Status Key Messages Quick Reference List.....	114
<b>FIGURE 34</b> - Operation Data .....	118
<b>FIGURE 35</b> - Setpoints Quick Reference List .....	130
<b>FIGURE 36</b> - Unit Keys Options Programming Quick Reference List.....	136
<b>FIGURE 37</b> - Micro Panel Connections.....	138
<b>FIGURE 38</b> - Leaving Water Temperature Control Example .....	150
<b>FIGURE 39</b> - Setpoint Adjust.....	151
<b>FIGURE 40</b> - Condenser Fan Locations.....	155
<b>FIGURE 41</b> - Microboard Layout.....	164
<b>FIGURE 42</b> - I/O Board Relay Contact Architecture.....	168
<b>FIGURE 43</b> - Printer to Microboard Electrical Connections.....	169

## LIST OF TABLES

<b>TABLE 1</b> - Canadian Registration Numbers .....	16
<b>TABLE 2</b> - Complete Pin Number Description .....	24
<b>TABLE 3</b> - Temperatures and Flows .....	43
<b>TABLE 4</b> - Ethylene and Propylene Glycol Correction Factors .....	45
<b>TABLE 5</b> - Physical Data (English) 60 Hz .....	46
<b>TABLE 6</b> - Micropanel Power Supply .....	48
<b>TABLE 7</b> - Voltage Range .....	48
<b>TABLE 8</b> - Pump Electrical Data (60 hz) .....	49
<b>TABLE 9</b> - Transformer Load .....	49
<b>TABLE 10</b> - Electrical Data Without Pumps .....	50
<b>TABLE 11</b> - Wiring Lugs .....	54
<b>TABLE 12</b> - Cooling Setpoint, Programmable Limits and Defaults .....	126
<b>TABLE 13</b> - Program Key Limits and Default .....	128
<b>TABLE 14</b> - Minimum, Maximum and Default Values .....	138
<b>TABLE 15</b> - Values Required for BAS Communication .....	139
<b>TABLE 16</b> - Real Time Error Numbers .....	140
<b>TABLE 17</b> - Native Bacnet, Modbus and N2 Communications Data Map .....	141
<b>TABLE 18</b> - Yorktalk 2 Communications Data Map .....	145
<b>TABLE 19</b> - Sample Compressor Staging for Return Water Control .....	151
<b>TABLE 20</b> - Return Chilled Liquid Control for 4 Compressors (6 Steps) .....	151
<b>TABLE 21</b> - Lead/Lag Return Chilled Liquid Control for 4 Compressors (6 Steps) .....	152
<b>TABLE 22</b> - YLAA Standard Condenser Fan Control Using Discharge Pressure Only (2, 3, or 4 Fans Per System) .....	156
<b>TABLE 23</b> - YLAA Standard Condenser Fan Control Using Discharge Pressure Only (5 or 6 Fans Per System) .....	157
<b>TABLE 24</b> - Compressor Operation Load Limiting .....	158
<b>TABLE 25</b> - I/O Digital Inputs .....	163
<b>TABLE 26</b> - I/O Digital Outputs .....	163
<b>TABLE 27</b> - I/O Analog Inputs .....	163
<b>TABLE 28</b> - I/O Analog Outputs .....	163
<b>TABLE 29</b> - Outdoor Air Sensor Temperature/Voltage/Correlation .....	165
<b>TABLE 30</b> - Entering/Leaving Chilled Liquid Temp. Sensor, Temperature/Voltage Correlation .....	166
<b>TABLE 31</b> - Pressure Transducers .....	167
<b>TABLE 32</b> - Troubleshooting .....	170
<b>TABLE 33</b> - SI Metric Conversion .....	177

THIS PAGE INTENTIONALLY LEFT BLANK

## SECTION 1 – GENERAL CHILLER INFORMATION AND SAFETY

### INTRODUCTION

YORK YLAA chillers are manufactured to the highest design and construction standards to ensure high performance, reliability and adaptability to all types of air conditioning installations.

Rigging and lifting should only be done by a professional rigger in accordance with a written rigging and lifting plan. The most appropriate rigging and lifting method will depend on job specific factors, such as the rigging equipment available and site needs. Therefore a professional rigger must determine the rigging and lifting method to be used, and it is beyond the scope of the manual to specify rigging and lifting details.

This manual contains all the information required for correct installation and commissioning of the unit, together with operating and maintenance instructions. The manuals should be read thoroughly before attempting to operate or service the unit.

All procedures detailed in the manuals, including installation, commissioning and maintenance tasks must only be performed by suitably trained and qualified personnel.

The manufacturer will not be liable for any injury or damage caused by incorrect installation, commissioning, operation or maintenance resulting from a failure to follow the procedures and instructions detailed in the manuals.

### WARRANTY

Johnson Controls warrants all equipment and materials against defects in workmanship and materials for a period of eighteen months from date of shipment, or 12 months from date of start-up, whichever occurs first, unless labor or extended warranty has been purchased as part of the contract.

The warranty is limited to parts only replacement and shipping of any faulty part, or sub-assembly, which has failed due to poor quality or manufacturing errors. All claims must be supported by evidence that the failure has occurred within the warranty period, and that the unit has been operated within the designed parameters specified.

All warranty claims must specify the unit model, serial number, order number and run hours/starts. Model and

serial number information is printed on the unit identification plate.

The unit warranty will be void if any modification to the unit is carried out without prior written approval from Johnson Controls.

For warranty purposes, the following conditions must be satisfied:

- The initial start of the unit must be carried out by trained personnel from an Authorized Johnson Controls Service Center (*see SECTION 6 – COMMISSIONING*).
- Only genuine YORK approved spare parts, oils, coolants, and refrigerants must be used.
- All the scheduled maintenance operations detailed in this manual must be performed at the specified times by suitably trained and qualified personnel (*see SECTION 10 – MAINTENANCE*).
- Failure to satisfy any of these conditions will automatically void the warranty (*see Warranty on this page*).

### HANDLING

These units are shipped as completely assembled units containing full operating charge, and care should be taken to avoid damage due to rough handling.

### SAFETY AND QUALITY

#### Standards for Safety and Quality

YLAA chillers are designed and built within an ISO 9002 accredited design and manufacturing organization. The chillers comply with the applicable sections of the following Standards and Codes:

- ANSI/ASHRAE Standard 15 - Safety Code for Mechanical Refrigeration.
- ANSI/NFPA Standard 70 - National Electrical Code (N.E.C.).
- ASME Boiler and Pressure Vessel Code - Section VIII Division 1.
- ARI Standard 550/590 - Positive Displacement Compressors and Air Cooled Rotary Screw Water Chilling Packages.

- ASHRAE 90.1 - Energy Efficiency compliance.
- Conform to Intertek Testing Services, formerly ETL, for construction of chillers and provide ETL/cETL listing label.
- Manufactured in facility registered to ISO 9002.
- OSHA – Occupational Safety and Health Act.

In addition, the chillers conform to Underwriters Laboratories (U.L.) for construction of chillers and provide U.L./cU.L. Listing Label.

### Responsibility for Safety

Every care has been taken in the design and manufacture of the unit to ensure compliance with the safety requirements listed above. However, the individual rigging, lifting, maintaining, operating or working on any machinery is primarily responsible for:

- Personal safety, safety of other personnel, and the machinery.
- Correct utilization of the machinery in accordance with the procedures detailed in the manuals.

### ABOUT THIS MANUAL

The contents of this manual include suggested best working practices and procedures. These are issued for guidance only, and they do not take precedence over the above stated individual responsibility and/or local safety regulations.

This manual and any other document supplied with the unit are the property of Johnson Controls which reserves all rights. They may not be reproduced, in whole or in part, without prior written authorization from an authorized Johnson Controls representative.

### MISUSE OF EQUIPMENT

#### Suitability for Application

The unit is intended for cooling water or glycol solutions and is not suitable for purposes other than those specified in these instructions. Any use of the equipment other than its intended use, or operation of the equipment contrary to the relevant procedures may result in injury to the operator, or damage to the equipment.

The unit must not be operated outside the design parameters specified in this manual.

### Structural Support

Structural support of the unit must be provided as indicated in these instructions. Failure to provide proper support may result in injury to the operator, or damage to the equipment and/or building.

### Mechanical Strength

The unit is not designed to withstand loads or stresses from adjacent equipment, pipework or structures. Additional components must not be mounted on the unit. Any such extraneous loads may cause structural failure and may result in injury to the operator, or damage to the equipment.

### General Access

There are a number of areas and features, which may be a hazard and potentially cause injury when working on the unit unless suitable safety precautions are taken. It is important to ensure access to the unit is restricted to suitably qualified persons who are familiar with the potential hazards and precautions necessary for safe operation and maintenance of equipment containing high temperatures, pressures and voltages.

### Pressure Systems

The unit contains refrigerant vapor and liquid under pressure, release of which can be a danger and cause injury. The user should ensure that care is taken during installation, operation and maintenance to avoid damage to the pressure system. No attempt should be made to gain access to the component parts of the pressure system other than by suitably trained and qualified personnel.

### Electrical

The unit must be grounded. No installation or maintenance work should be attempted on the electrical equipment without first switching power OFF, isolating and locking-off the power supply. Servicing and maintenance on live equipment must only be performed by suitably trained and qualified personnel. No attempt should be made to gain access to the control panel or electrical enclosures during normal operation of the unit.

### **Rotating Parts**

Fan guards must be fitted at all times and not removed unless the power supply has been isolated. If ductwork is to be fitted, requiring the wire fan guards to be removed, alternative safety measures must be taken to protect against the risk of injury from rotating fans.

### **Sharp Edges**

The fins on the air-cooled condenser coils have sharp metal edges. Reasonable care should be taken when working in contact with the coils to avoid the risk of minor abrasions and lacerations. The use of gloves is recommended.

Frame rails, brakes, and other components may also have sharp edges. Reasonable care should be taken when working in contact with any components to avoid risk of minor abrasions and lacerations.

### **Refrigerants and Oils**

Refrigerants and oils used in the unit are generally non-toxic, non-flammable and non-corrosive, and pose no special safety hazards. Use of gloves and safety glasses is, however, recommended when working on the unit. The build up of refrigerant vapor, from a leak for example, does pose a risk of asphyxiation in confined or enclosed spaces and attention should be given to good ventilation.

### **High Temperature and Pressure Cleaning**

High temperature and pressure cleaning methods (e.g. steam cleaning) should not be used on any part of the pressure system as this may cause operation of the pressure relief device(s). Detergents and solvents, which may cause corrosion, should also be avoided.

### **Emergency Shutdown**

In case of emergency, the control panel is fitted with a Unit Switch to stop the unit in an emergency. When operated, it removes the low voltage 120VAC electrical supply from the unit controller, thus shutting down the unit.

THIS PAGE INTENTIONALLY LEFT BLANK

## SECTION 2 – PRODUCT DESCRIPTION

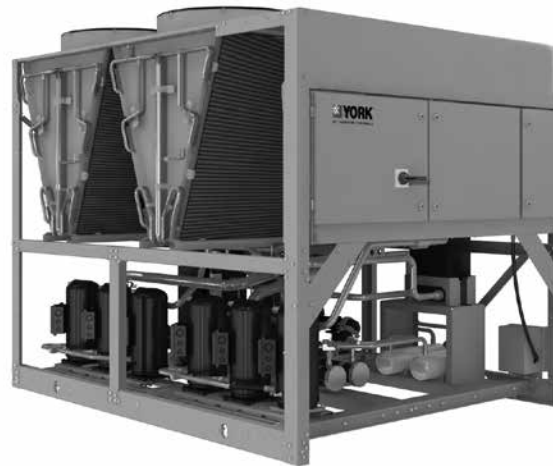

### INTRODUCTION

YORK YLAA Air-Cooled Scroll Chillers provide chilled water for all air conditioning applications using central station air handling or terminal units. They are completely self-contained and are designed for outdoor (roof or ground level) installation. Each complete packaged unit includes hermetic scroll compressors, a liquid cooler, air cooled condenser, a charge of Zero Ozone Depletion Potential Refrigerant R-410A and a weather resistant microprocessor control center, all mounted on a rugged steel base.

The units are completely assembled with all interconnecting refrigerant piping and internal wiring, ready for field installation.

Prior to delivery, the packaged unit is pressure-tested, evacuated, and fully charged with Refrigerant R-410A and oil. After assembly, a complete operational test is performed with water flowing through the cooler to assure that the refrigeration circuit operates correctly.

The unit structure is heavy-gauge, galvanized steel. This galvanized steel is coated with baked-on powder paint, which, when subjected to ASTM B117 1000 hour, salt spray testing, yields a minimum ASTM 1654 rating of “6”. Units are designed in accordance with NFPA 70 (National Electric Code), ASHRAE/ANSI 15 Safety code for mechanical refrigeration, ASME, and rated in accordance with ARI Standard 550/590.

### GENERAL SYSTEM DESCRIPTION

#### Compressors

The chiller has suction-gas cooled, hermetic, scroll compressors. The YLAA compressors incorporate a compliant scroll design in both the axial and radial direction. All rotating parts are statically and dynamically balanced. A large internal volume and oil reservoir provides greater liquid tolerance. Compressor crankcase heaters are also included for extra protection against liquid migration.

#### Brazed Plate Evaporator

The compact, high efficiency Brazed Plate Heat Exchanger (BPHE) is constructed with 316L stainless steel corrugated channel plates with a filler material between each plate. It offers excellent heat transfer performance with a compact size and low weight, reducing structural steel requirements on the job site.

The heat exchanger is manufactured in a precisely controlled vacuum-brazing process that allows the filler material to form a brazed joint at every contact point between the plates, creating complex channels. The arrangement is similar to older plate and frame technology, but without gaskets and frame parts.

Water inlet and outlet connections are grooved for compatibility with field supplied ANSI/AWWA C-606 couplings.

The evaporator is equipped with a thermostat-controlled heater. The heater provides freeze protection for the evaporator down to -20°F (-29°C) ambient. The evaporator is covered with 3/4" flexible, closed-cell, foam insulation (K=0.25).

A 1/16" (1.6mm) mesh wye-strainer is provided as standard for installation upstream of the heat exchanger to prevent clogging from water system debris.

### Canadian Registration Number (CRN) Application & Proof of Conformance

Since all YLAA brazed plate evaporators are categorized as pressure "H" fittings per CSA-B51, a CRN label or marking is not provided on the evaporator. According to the Canadian Standards Association's Boiler, Pressure Vessel, and Pressure Piping Code B-51 (2009 version), a product registered as a category "H" fitting does not require a label or marking displaying the CRN.

**TABLE 1 - CANADIAN REGISTRATION NUMBERS**

CANADIAN PROVINCE	CRN #
BC	OH13953.51
AB	OH13953.52
ON	OH13953.5
PQ/MB/SK	OH13953.56
NB	OH13953.57
NS	OH13953.58
PEI	OH13953.59
NF	OH13953.50
NU	OH13953.5N
NWT	OH13953.5T
YU	OH13953.5Y

### Condenser

#### Microchannel Condenser (MCHX)

MCHX Condensers are made of a single material to avoid galvanic corrosion due to dissimilar metals. MCHX and headers are brazed as one piece. Integral sub cooling is included. The design working pressure of the MCHX is 650 PSIG (45 bar). MCHX Condenser is easily washable with clear water.

### Fans

The condenser fans are composed of corrosion resistant aluminum hub and glass-fiber reinforced polypropylene composite blades molded into a low noise airfoil section. They are designed for maximum efficiency and are statically and dynamically balanced for

vibration free operation. They are directly driven by independent motors, and positioned for vertical air discharge. The fan guards are constructed of heavy gauge, rust resistant, coated steel. All blades are statically and dynamically balanced for vibration free operation.

### Motors

The fan motors are Totally Enclosed Air-Over, and are current protected. They feature ball bearings that are double sealed and permanently lubricated.

### Control Center

All controls are contained in a NEMA 3R/12 cabinet with hinged outer door and includes a Liquid Crystal Display with Light Emitting Diode backlighting for outdoor viewing:

- Two display lines
- Twenty characters per line

### Display/Print Keys

- Color coded 12-button non-tactile keypad with sections for display and print of typical information:
- Chilled liquid temperatures
- Ambient temperature
- System pressures (each circuit)
- Operating hours and starts (each compressor)
- Print calls up to the liquid crystal display
- Operating data for the systems
- History of fault shutdown data for up to the last six fault shutdown conditions.
- An RS-232 port, in conjunction with this press-to-print button, is provided to permit the capability of hard copy print-outs via a separate printer (by others).

### Entry Keys

This section is used to enter setpoints or modify system values.

### Setpoints Keys

Updating can be performed to:

- Chilled liquid temperature setpoint and range
- Remote reset temperature range
- Set daily schedule/holiday for start/stop
- Manual override for servicing
- Low and high ambient cutouts

- Number of compressors
- Low liquid temperature cutout
- Low suction pressure cutout
- High discharge pressure cutout
- Anti-recycle timer (compressor start cycle time)
- Anti-coincident timer (delay compressor starts)

### Unit Keys

This section is used to:

- Set time
- Set unit options

### Oper Data Key

The microprocessor control center is capable of displaying the following:

- Return and leaving liquid temperature
- Low leaving liquid temperature cutout setting
- Low ambient temperature cutout setting
- Outdoor air temperature
- English or Metric data
- Suction pressure cutout setting
- Each system suction pressure
- Discharge pressure (optional)
- Liquid Temperature Reset via a Johnson Controls ISN DDC or Building Automation System (by others) via a 4 to 20 milliamp or 0 to 10VDC input
- Anti-recycle timer status for each system
- Anti-coincident system start timer condition
- Compressor run status
- No cooling load condition
- Day, date and time
- Daily start/stop times
- Holiday status
- Automatic or manual system lead/lag control
- Lead system definition
- Compressor starts and operating hours (each compressor)
- Status of hot gas valves, evaporator heater and fan operation
- Run permissive status
- Number of compressors running

- Liquid solenoid valve status
- Load and unload timer status
- Water pump status

Provisions are included for: pumpdown at shutdown; optional remote chilled water temperature reset and two steps of demand load limiting from an external building automation system. Unit alarm contacts are standard.

The operating program is stored in non-volatile memory battery backed RAM to eliminate chiller failure due to AC powered failure/battery discharge. Programmed setpoints are retained in lithium battery-backed RTC memory for 5 years minimum.

### COMMUNICATIONS

- Native communication capability for BACnet (MS/TP) and Modbus.
- Optional communication available for N2 and LON via eLink Gateway option.

### BUILDING AUTOMATION SYSTEM INTERFACE

The Microprocessor Board can accept a 4 to 20 milliamp, or 0 to 10VDC input to reset the leaving chiller liquid temperature from a Building Automation System.

- The standard unit capabilities include remote start-stop, remote water temperature reset via a PWM 4 to 20 milliamp or 0 to 10VDC input signal or up to two stages of demand (load) limiting depending on model.
- The standard control panel can be directly connected to a Johnson Controls Building Automated System.

### POWER PANEL

Each panel contains:

- Compressor power terminals
- Compressor motor starting contactors per I.E.C.\*\*
- Control power terminals to accept incoming for 115-1-60 control power
- Fan contactors and overload current protection

The power wiring is routed through liquid-tight conduit to the compressors and fans.

## ACCESSORIES AND OPTIONS

### Power Options

#### **Compressor Power Connections**

Single-point terminal block connection(s) are provided as standard. The following power connections are available as options. (See electrical data for specific voltage and options availability.) **(Factory-mounted)**

#### **Single-Point Supply Terminal Block**

Includes enclosure, terminal-block and interconnecting wiring to the compressors. Separate external protection must be supplied, by others, in the incoming compressor-power wiring. (Do not include this option if either the Single-Point Non-Fused Disconnect Switch or Single-Point Circuit Breaker options have been included.)

#### **Single-Point Non-Fused Disconnect Switch**

Unit-mounted disconnect switch with external, lockable handle (in compliance with Article 440-14 of N.E.C.), can be supplied to isolate the unit power voltage for servicing. Separate external fusing must be supplied, by others in the power wiring, which must comply with the National Electrical Code and/or local codes.

#### **Single-Point Circuit Breaker**

A unit mounted circuit breaker with external, lockable handle (in compliance with N.E.C. Article 440-14), can be supplied to isolate the power voltage for servicing. (This option includes the Single-Point Power connection.)

#### **Control Transformer**

Converts unit power voltage to 115-1-60 (2.0 or 3.0 KVA capacity). Factory mounting includes primary and secondary wiring between the transformer and the control panel. **(Factory-mounted)**

### Control Options

#### **Ambient Kit (Low)**

Units will operate to 30°F (-1.1°C). This accessory includes all necessary components to permit chiller operation to 0°F (-18°C). (This option includes the Discharge Pressure Transducer / Readout Capability option.) For proper head pressure control in applications below 30°F (-1°C) where wind gusts may exceed 5 mph, it is recommended that Optional Condenser Louvered Enclosure Panels also be included. **(Factory-mounted)**

#### **High Ambient Kit With Sunshield**

Allows units to operate when the ambient temperature is above 115°F (46°C). Includes sun shield panels and discharge pressure transducers.

#### **Language LCD and Keypad Display**

Spanish, French, German, and Italian unit LCD controls and keypad display available. Standard language is English.

### Compressor, Piping, Evaporator Options

#### **Low Temperature Glycol**

Replaces standard Thermostatic Expansion Valves with Electronic Expansion Valves to achieve leaving glycol temperatures as low as 10°F (-12°C). Required for any leaving liquid temperature below 30°F (-1°C). Electronic Expansion Valves permit operation at both low temperatures and comfort cooling applications without a capacity loss or derate at either condition. **(Factory installed)**

#### **Chicago Code Relief Valves**

Unit will be provided with relief valves to meet Chicago code requirements. **(Factory-Mounted)**

#### **Service Suction Isolation Valve**

Service suction (ball-type) isolation valves are added to unit per system (discharge service ball-type isolation valve is standard on each circuit). **(Factory-Mounted)**

#### **Hot Gas By-Pass**

Permits continuous, stable operation at capacities below the minimum step of compressor unloading to as low as 5% capacity (depending on both the unit and operating conditions) by introducing an artificial load on the cooler. Hot gas by-pass is installed on only refrigerant system #1 on two-circuited units. **(Factory-Mounted)**

#### **Flanges (ANSI/AWWA C-606 couplings Type)**

Consists of (2) Flange adapter for grooved end pipe (standard 150 psi [10.5 bar] cooler). (Not available on optional DX cooler 300 PSIG DWP waterside.) **(Field-mounted)**

#### **Flow Switch**

A thermal dispersion type flow switch provides accurate, low maintenance flow proving and is included standard. It is factory wired and installed in the extension pipe between evaporator outlet and edge of chiller. The extension pipe is secured to the chiller frame for shipping to avoid risk of damage to evaporator

and is easily attached to the evaporator at startup using the supplied ANSI/AWWA C-606 connector. The flow switch can be deleted if alternate or existing flow switch is field supplied.

### **Heat Recovery Condenser**

A partially condensing refrigerant to liquid condenser recovers heat off both refrigerant circuits and rejects into a single liquid circuit. Factory installed between the compressor discharge and the condenser (air) coils to capture the maximum amount of heat. Capable of recovering up to 85% total heat of rejection (cooling load plus work input); temperatures as high as 140°F (60°C) are possible.

### **Hydro-Kit**

Factory installed Hydro-Kit suitable for water and glycol systems with up to 35% glycol at leaving temperatures down to 20°F. The hydro-kit option is available in a single or dual configuration (dual as standby duty only), with totally enclosed permanently lubricated pump motors.

The hydro-kit option comes standard with a balancing valve, discharge check valve, discharge shutoff valve, thermal dispersion flow switch, pressure ports, inlet wye-strainer, bleed and drain valves and frost protection.

Service shut off valves, additional pressure ports and expansion tanks are optional within the hydro-kit option.

### **Condenser and Cabinet Options**

MCHX Condenser protection against corrosive environments is available by choosing any of the following options. For additional application recommendations, See *FORM 150.12-ESI*. **(Factory-Mounted)**

### **Post-Coated Dipped MCHX Condenser**

The unit MCHX is constructed with post dipped-epoxy MCHX condenser. This is recommended for seashore and other corrosive applications (with the exception of strong alkalies, oxidizers and wet bromine, chlorine and fluorine in concentrations greater than 100 ppm).

### **Enclosure Panels (Unit)**

Tamper proof Enclosure Panels prevent unauthorized access to units. Enclosure Panels can provide an aesthetically pleasing alternative to expensive fencing. Additionally, for proper head pressure control, Johnson Controls recommends the use of Condenser Louvered Panels for winter applications where wind gusts may

exceed five miles per hour. The following types of enclosure panels are available:

- **Wire Panels (Full Unit)** - Consists of welded wire-mesh guards mounted on the exterior of the unit. Prevents unauthorized access, yet provides free air flow. **(Factory-Mounted)**
- **Wire/Louvered Panels** - Consists of welded wire-mesh panels on the bottom part of unit and louvered panels on the condenser section of the unit. **(Factory-Mounted)**
- **Louvered Panels (MCHX Condenser Only)** - Louvered Panels are mounted on the sides and ends of the MCHX condenser for protection. **(Factory-Mounted)**
- **Louvered Panels (Full Unit)** - Louvered panels surround the front, back, and sides of the unit. They prevent unauthorized access and visually screen unit components. Unrestricted air flow is permitted through generously sized louvered openings. This option is applicable for any outdoor design ambient temperature up to 115°F (46°). **(Factory-Mounted)**

### **MCHX End Hail Guard**

Louvered panel attached to exposed MCHX end. **(Factory-Mounted)**

### **Sound Attenuation**

One or both of the following sound attenuation options are recommended for residential or other similar sound sensitive locations:

- **Compressor Acoustic Sound Blanket** - Each compressor is individually enclosed by an acoustic sound blanket. The sound blankets are made with one layer of acoustical absorbent textile fiber of 5/8" (15mm) thickness; one layer of anti-vibrating heavy material thickness of 1/8" (3mm). Both are closed by two sheets of welded PVC, reinforced for temperature and UV resistance. **(Factory-Mounted)**
- **Ultra Quiet Fans** - Lower RPM, 8-pole fan motors are used with steeper-pitch fans. **(Factory-Mounted)**

### **Vibration Isolators**

Level adjusting, spring type 1" (25.4mm) or seismic deflection or neoprene pad isolators for mounting under unit base rails. **(Field-mounted)**

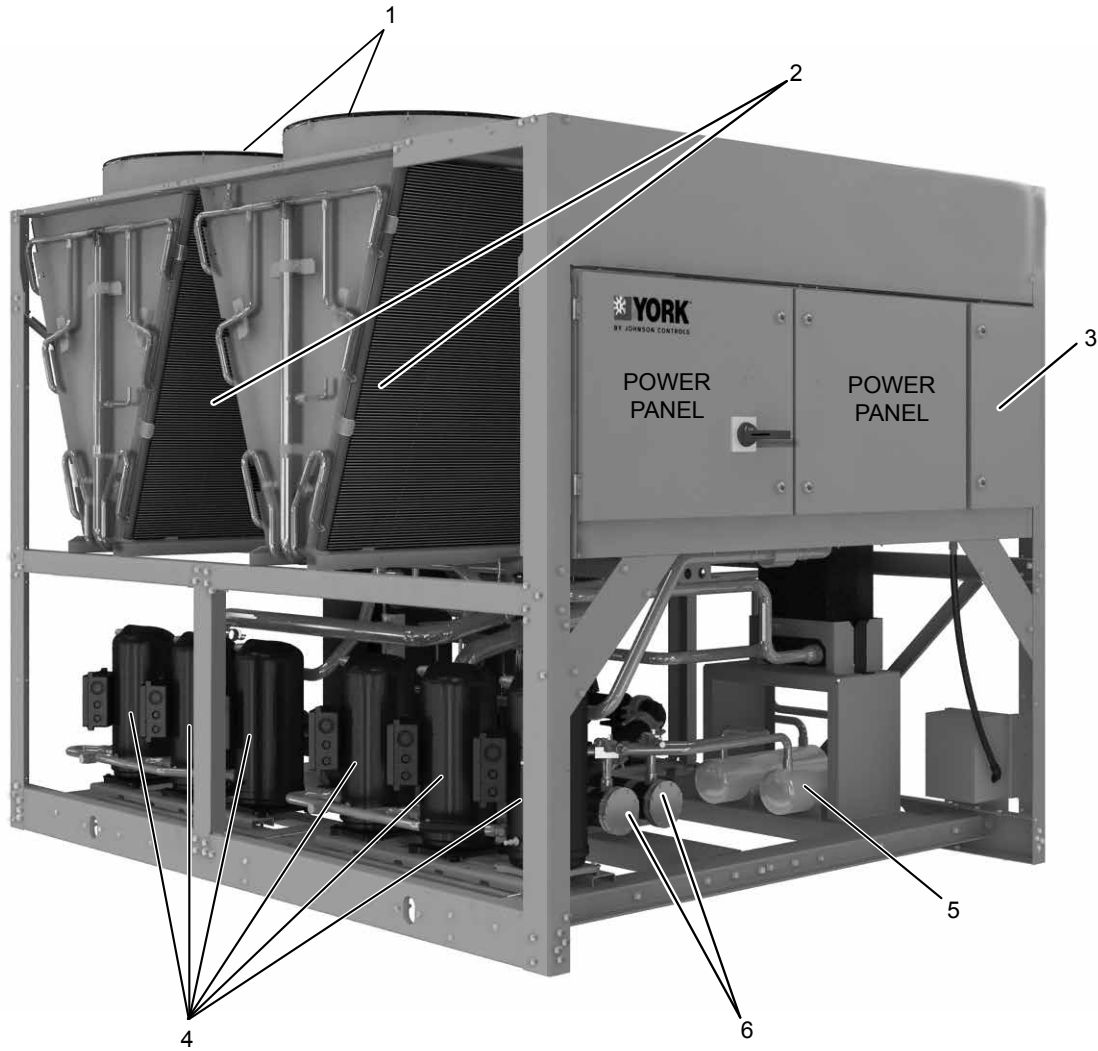

ITEM	DESCRIPTION
1	Fan Assemblies
2	MCHX Condenser
3	Control Panel
4	Compressors
5	Receiver Included with Optional Heat Recovery Condenser
6	Filter Driers

**FIGURE 1 - UNIT COMPONENTS (FRONT)**

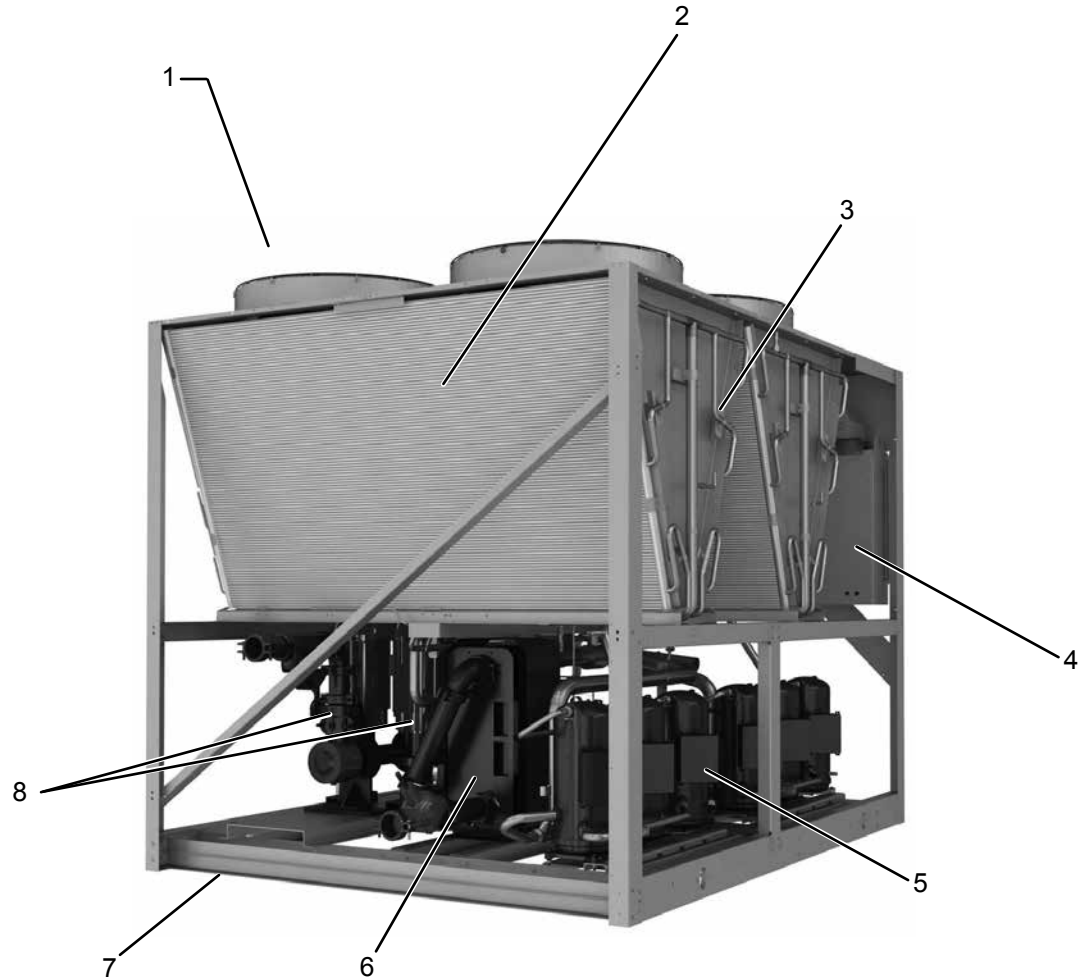

ITEM	DESCRIPTION
1	Fan Deck
2	MCHX Condenser
3	Coil Headers
4	Control and Power Panels
5	Compressors
6	Brazed Plate Evaporator
7	Formed Steel Base Rails
8	Hydro-Kit Pumps And Motors (Optional)

**FIGURE 2 - UNIT COMPONENTS (SIDE)**

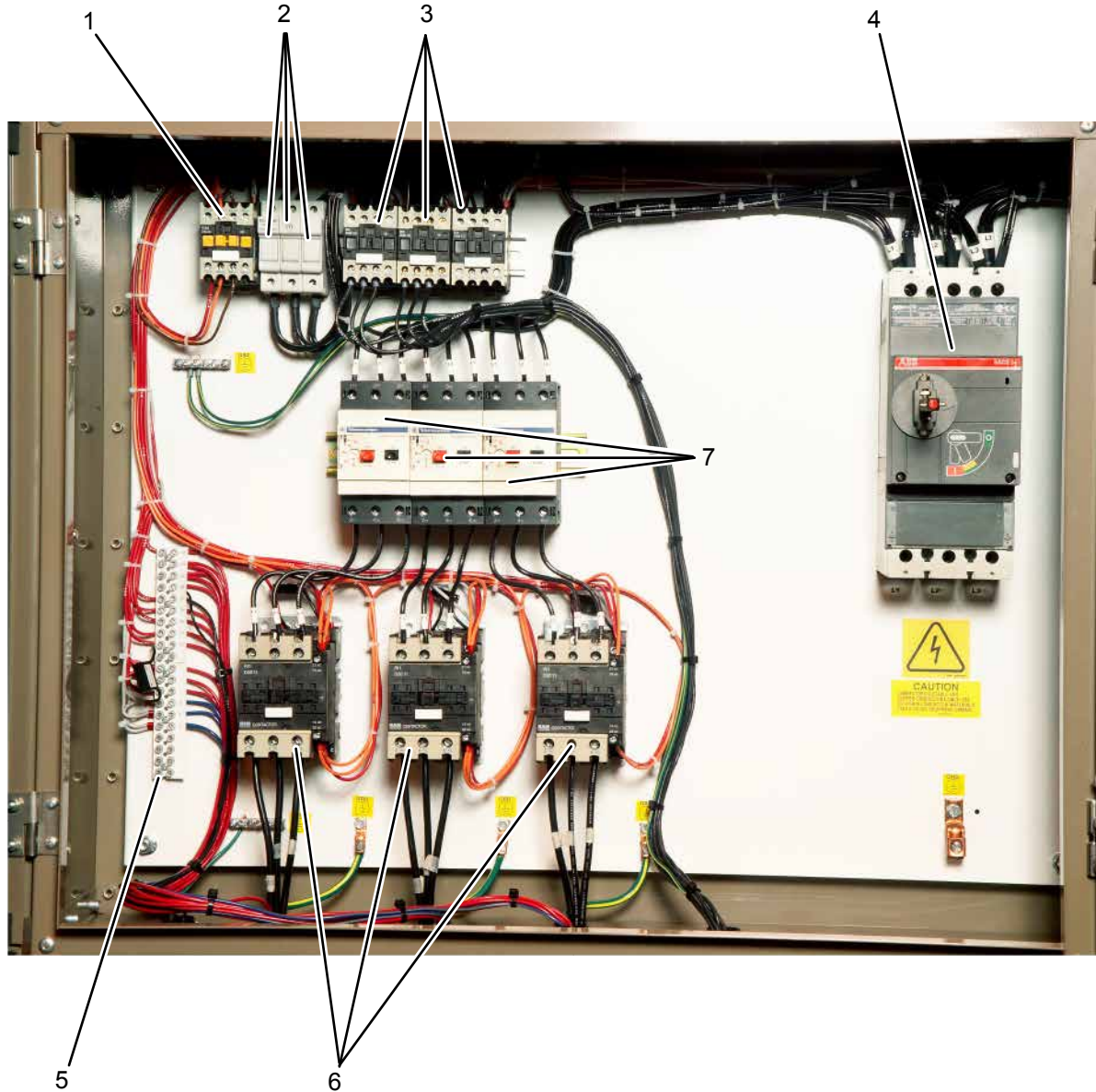

LD13248

ITEM	DESCRIPTION
1	Fan Contactor
2	Fan Fuses
3	Fan Contactor
4	Disconnect Switch (Optional)
5	XTBF1
6	Compressor Contactors
7	Compressor Overloads

**FIGURE 3 - POWER PANEL COMPONENTS**

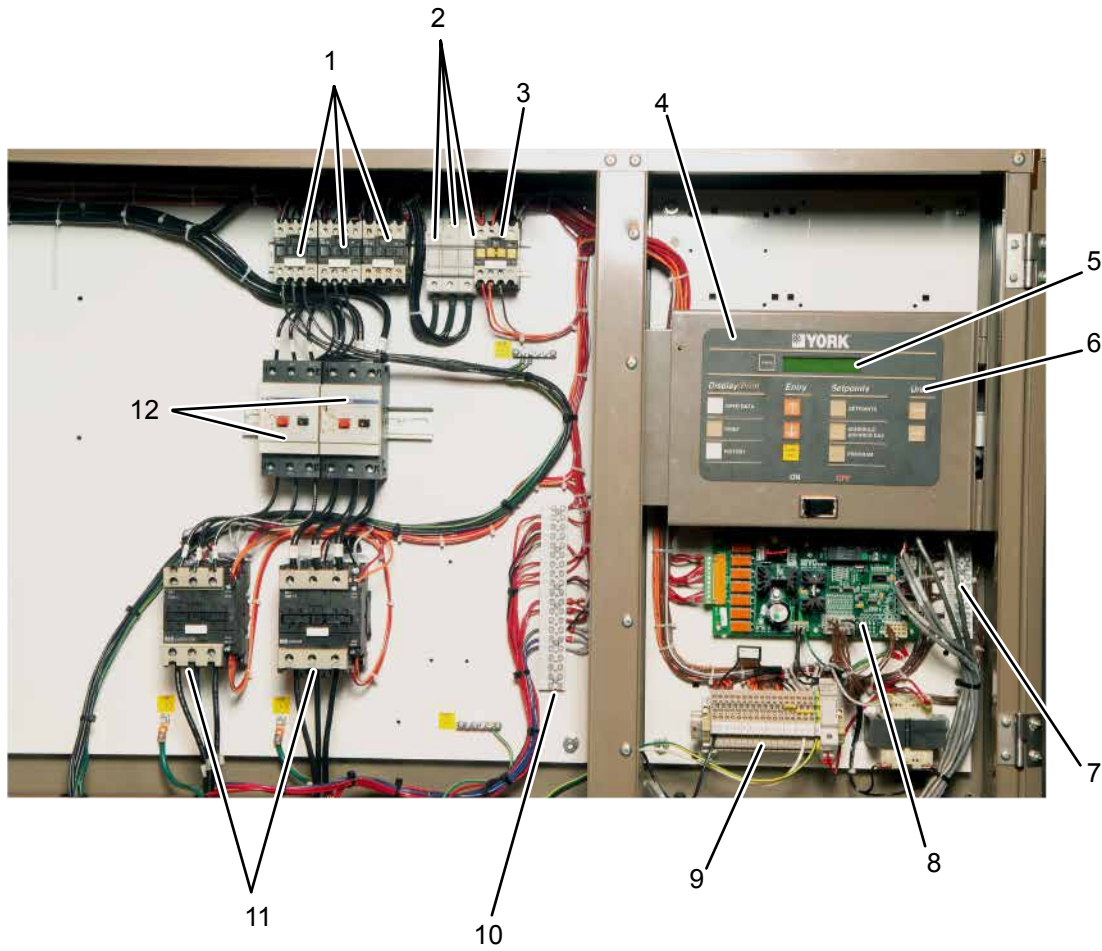

LD13248

ITEM	DESCRIPTION
1	Fan Contactor
2	Fan Fuses
3	Control Relay
4	Microcomputer Control Center
5	Display
6	Keypad
7	XTBC1
8	Microboard
9	XTCB2
10	XTBF2
11	Compressor Contactors
12	Compressor Overloads

**FIGURE 4 - POWER PANEL / CONTROL COMPONENTS**

**PRODUCT IDENTIFICATION NUMBER (PIN)****TABLE 2 - COMPLETE PIN NUMBER DESCRIPTION**

FEATURE	FEATURE DESCRIPTION	OPTION	OPTION DESCRIPTION
MODEL	Model (PIN 1-4)		YLAA
CAPACITY	Capacity (PIN 5-8)	0058	0058
		0065	0065
		0070	0070
		0080	0080
		0081	0081
		0089	0089
		0092	0092
		0100	0100
		0101	0101
		0115	0115
		0120	0120
		0125	0125
		0136	0136
		0142	0142
		0150	0150
		0155	0155
		0156	0156
0170	0170		
0175	0175		
0200	0200		
UNIT	Unit Designator (PIN 9)	S	Standard Efficiency
		H	High Efficiency
REF.	Refrigerant (PIN 10)	E	R-410A
VOLTS	Voltage (PIN 11 & 12)	17	200/3/60
		28	230/3/60
		40	380/3/60
		46	460/3/60
		50	380-415/3/50
		58	575/3/60
STARTER	Starter (PIN 13)	X	Across the Line starter
		T	Soft Start
DESIGN	Design Series (PIN 14)	A	Design Series A (MicroChannel) Copeland Compressor
		C	Design Series C (MicroChannel CE/ETL Panel) Copeland Compressor
		D	Design Series D (MicroChannel) Bitzer Compressor
		F	Design Series F (MicroChannel CE/ETL Panel) Bitzer Compressor
DEV	Development Level (PIN 15)	B	Development Level B
POWER	Power Field (PIN 16 & 17)	SX	SP Supply TB
		SD	SP NF Disconnect Switch
		BC	SP Circuit Breaker w/ Lockable Handle, 65kA SCWR
		BX	SP Circuit Breaker w/ Lockable Handle
		MB	MP Supply w/Ind Sys CB&L Ext Handles
TRANS	Cntrl Transformer (PIN 18)	X	No Control Transformer Required
		T	Control Transformer Required
		Q	Special Control Transformer Required

**TABLE 2 - COMPLETE PIN NUMBER DESCRIPTION (CONT'D)**

FEATURE	FEATURE DESCRIPTION	OPTION	OPTION DESCRIPTION
PFC	Power Factor Capacitor (PIN 19)	X	No Power Capacitor required
		C	Power Capacitor required
		Q	Special Power Capacitor required
AMB	Ambient Kits (PIN 20)	H	High Ambient Kit Standard (factory)
		A	Both Low/High Ambient Kit required (factory)
		B	Both Low/High Ambient Kit w/Sunshield (factory)
		S	High Ambient Kit w/Sunshield (factory)
		Q	Special Ambient Kit required
BAS	Bas Reset/Offset (PIN 21)	X	No Selection
		L	LON E-Link
		S	SC-Equip Board
		Q	Special Quote
LCD	Language (PIN 22)	X	English
		S	Spanish
		C	Chinese (Simplified) (Not Applicable to eLogia)
		E	English with Chinese Displayed Board (Not Applicable to eLogia)
		F	French
		G	German
		I	Italian
RDOUT	Readout Kits (PIN 23)	B	Both Discharge & Suction Pressure Transducer Readout required
		Q	Special Pressure Readout required
SAFETY	Safety Codes (PIN 24)	C	European Safety Code ( CE )
		G	China Safety Code (GB) (Not Applicable to eLogia)
		L	N American Safety Code (cUL/cETL)
SENSOR	PIN 25	X	X
		Q	Special Quote
PUMP	Motor Current Module (PIN 26)	C	Motor Current Module
		Q	Special Quote
REMOTE	Remote Panel (PIN 27)	X	No Remote Panel required
		Q	Special Remote Panel required
SEQ	Sequence Kit (PIN 28)	X	No Sequence Kit required
		Q	Special Sequence Kit required
TEMP	Leaving Water Temp (PIN 29,30)	NUM	Leaving Water Temp = Temp/Num Deg.
CHICAGO	Chicago Code Kit (PIN 31)	X	No Chicago Code Kit required
		B	Both Chicago Code & Serv Isolation
		C	Chicago Code Kit required
		G	Both Suction Service Valve and Dual Relief Valve (Europe only)
		R	Dual Relief Valves no Suction Service Valve (Europe only)
		S	Service Isolation Valves
		Q	Special Chicago Code Kit required
VALVES	Valves (PIN 32)	X	Standard Valves Req'd
		E	Electronic Expansion Valve
		Q	Special Optional Valves Req'd
HGBP	Hot Gas Bypass (PIN 33)	X	No Hot Gas Bypass required
		1	Hot Gas Bypass required - 1 circuit
		Q	Special Hot Gas Bypass required
GAUGE	PIN 34	X	X
		Q	Special Quote

2

**TABLE 2 - COMPLETE PIN NUMBER DESCRIPTION (CONT'D)**

FEATURE	FEATURE DESCRIPTION	OPTION	OPTION DESCRIPTION
OVERLOAD	PIN 35	X	X
		Q	Special Quote
PIN36	PIN 36	K	Quick Start
		Q	Special Quote
HTR	Crankcase Heater (Pin 37)	H	Crankcase Heater Standard
		Q	Special Crankcase Heater required
DWP	DWP (PIN 38)	X	150psig DWP Waterside
		3	300psig DWP Waterside
INS	Insulation (PIN 39)	X	Standard Insulation
		D	Double Thick Insulation
		Q	Special Insulation required
FLANGES	Flanges (PIN 40)	X	No Flanges required
		V	Victaulic Flanges required
		Q	Special Flanges required
FLOW	Flow Switch (PIN 41)	X	No Flow Switch required
		S	One Flow Switch Required
		Y	Flow Switch With Extension Kit
VESSEL	Vessel Codes (PIN 42)	A	ASME Pressure Vessel Codes
		E	PED Pressure Vessel Codes
		G	GB Pressure Vessel Codes
		Q	Special Quote
CLR	Cooler (PIN 43)	X	Standard Cooler Required
		R	Remote Cooler Required
PIN44	PIN 44	G	Flow Switch >= 10% Glycol
		W	Flow Switch < 10% Glycol
COILS	Coils (PIN 45)	X	Aluminum Coils
		P	Post Coated Dipped Coil
		T	Post Coated Microchannel Coils
HEAT	Heat Recovery (PIN 46)	X	No Option required
		H	Heat Recovery
		Q	Special Quote
FANMOTORS	Fan Motors (PIN 47)	X	TEAO Fan Motors
		Q	Special Fan Motors required
ENCL	Enclosure Panels (PIN 48)	X	No Enclosure required
		1	Wire (Full Unit) Encl Panels (factory)
		2	Wire (Full Unit) Encl Panels (field)
		3	Wire/Louvered Encl Panels (factory)
		4	Wire/Louvered Encl Panels (field)
		5	Louvered (Cond only) Encl Panels (factory)
		6	Louvered (Cond only) Encl Panels (field)
		7	Louvered (Full Unit) Encl Panels (factory)
		8	Louvered (Full Unit) Encl Panels (field)
		9	End Louver (End Hail Guard) Encl Panels (factory)
		A	End Louver (End Hail Guard) Encl Panels (field)
		B	Aesthetic Panel Kit only (factory)
		C	Aesthetic Panel Kit only (field)
		D	Aesthetic Panel Kit plus Hail Guards (factory)
		E	Aesthetic Panel Kit plus Hail Guards (field)
		Q	Special Enclosure Panels

**TABLE 2 - COMPLETE PIN NUMBER DESCRIPTION (CONT'D)**

FEATURE	FEATURE DESCRIPTION	OPTION	OPTION DESCRIPTION
ACOUSTIC	Acoustic Blanket (PIN 49)	X	No Acoustic Blanket required
		B	Acoustic Blanket Required
		E	Acoustic Enclosure
		Q	Special Acoustic Blanket required
SRDOCS	SR Documents (PIN 50)	X	No Documents Required
		A	Base, Material & Witness Documents
		B	Base Document
		M	Base & Material Documents
		W	Base & Witness Documents
		Q	Special Quote
PIN 51	PIN 51	X	X
		Q	Special Quote
FANS	Sound Fans (PIN 52)	X	Standard Low Sound Fan Required
		L	Ultra Quiet Fans Required
		G	High Air Flow Fan Required
		V	Standard Low Sound Fan with VSD Required
		M	Ultra Quiet Fans with VSD Required
		A	High Air Flow Fan Required (Vendor Specific)
		E	Low Sound Fan Required (Vendor Specific)
		S	High Static Fan Required (Vendor Specific)
		U	Ultra Quiet Fans Required (Vendor Specific)
2	2-Speed Fans Required (Vendor Specific)		
PAINT	PIN 53	X	X
		Q	Special Quote
ISOL	Vibration Isolators (PIN 54)	X	No Isolators required
		1	1" Deflection Isolators required
		N	Neoprene Isolators required
		S	2" Deflection Isolators required
		Q	Special Isolators required
PIN 55	PIN 55		Marketing Purposes Only!
PIN 56	PIN 56		Marketing Purposes Only!
SHIP	Ship Instructions (PIN 57)	X	No Containerization required with Shipping Bag
		A	Buy American Act Compliance with Shipping Bag
		B	Both Buy American Act Compliance and Container Shipped without Shipping Bag (Factory Prep)
		C	Container Shipped without Shipping Bag (Factory Load)
		D	Container Shipped with Shipping Bag (Factory Load US Port)
		E	Container Shipped with Shipping Bag (Factory Load Mexico Port)
		F	Container Shipped with Shipping Bag (Factory Prep)
		G	Both Buy America Act Compliance and Container Shipped with Shipping Bag (Factory Prep)
		M	Container Shipped without Shipping Bag (Factory Load Mexico Port)
		N	No Containerization required without Shipping Bag
		P	Container Shipped without Shipping Bag (Factory Prep)
		U	Buy American Act Compliance without Shipping Bag
Q	Special quote		

2

**TABLE 2 - COMPLETE PIN NUMBER DESCRIPTION (CONT'D)**

FEATURE	FEATURE DESCRIPTION	OPTION	OPTION DESCRIPTION
PIN 58	PIN 58		Marketing Purposes Only!
PKG	Pump Package (PIN 59)	X	No Pump
		A	Pump Kit A
		B	Pump Kit B
		C	Pump Kit C
		D	Pump Kit D
		E	Pump Kit E
		F	Pump Kit F
		G	Pump Kit G
		H	Pump Kit H
		I	Pump Kit I
		J	Pump Kit J
		K	Pump Kit K
		L	Pump Kit L
		M	Pump Kit M
		N	Pump Kit N
		O	Pump Kit O
		P	Pump Kit P
		R	Pump Kit R
		S	Pump Kit S
		T	Pump Kit T
U	Pump Kit U		
V	Pump Kit V		
W	Pump Kit W		
Y	Pump Kit Y		
Z	Pump Kit Z		
PKGOPT	Pump Package Options (PIN 60)	X	No Option
		1	Single Pump, Standard
		2	Single Pump, Full Feature
		3	Dual Pump, Standard
		4	Dual Pump, Full Feature
		5	VSD Single Pump, Full Feature
		6	VSD Dual Pump, Full Feature
PIN 61	PIN 61		Marketing Purposes Only!
LOC	Mfg Location	GZ	Guangzhou, China
		MTY	Monterrey, Mexico
		SAT	San Antonio, Texas

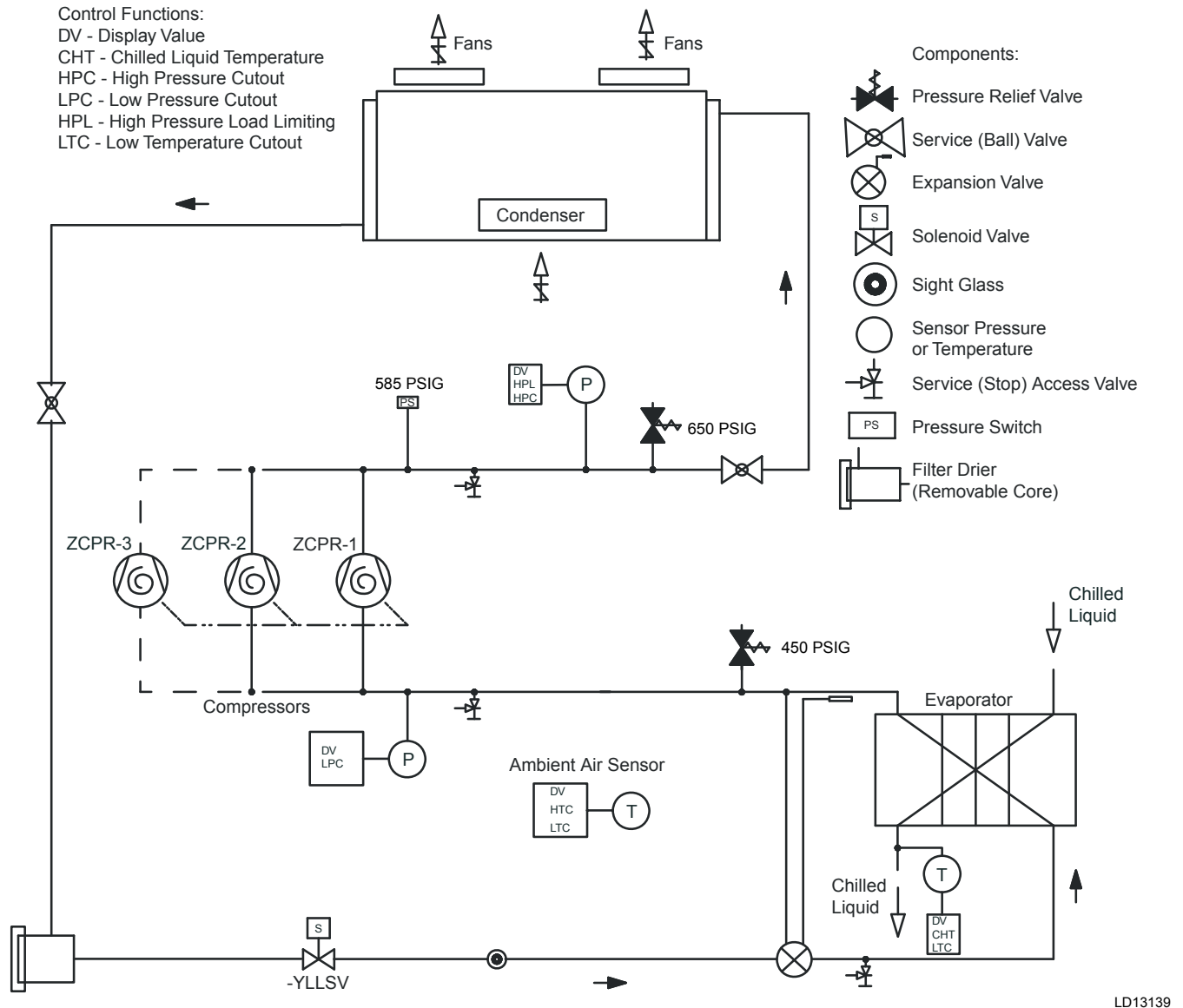

**FIGURE 5 - PROCESS AND INSTRUMENTATION DIAGRAM**

Low pressure liquid refrigerant enters the cooler and is evaporated and superheated by the heat energy absorbed from the chilled liquid passing through the cooler shell. Low pressure vapor enters at the compressor where pressure and superheat are increased. The

high pressure vapor is fed to the air cooled condenser coil and fans where the heat is removed. The fully condensed and subcooled liquid passes through the expansion valve where pressure is reduced and further cooling takes place before entering to the cooler.

THIS PAGE INTENTIONALLY LEFT BLANK

## SECTION 3 – HANDLING AND STORAGE

### DELIVERY AND STORAGE

To ensure consistent quality and maximum reliability, all units are tested and inspected before leaving the factory. Units are shipped completely assembled and containing refrigerant under pressure. Units are shipped without export crating unless crating has been specified on the Sales Order.

If the unit is to be put into storage, prior to installation, the following precautions should be observed:

- The chiller must be “blocked” so that the base is not permitted to sag or bow.
- Ensure that all openings, such as water connections, are securely capped.
- Do not store where exposed to ambient air temperatures exceeding 112 °F (44.5 °C).
- The condensers should be covered to protect the fins from potential damage and corrosion, particularly where building work is in progress.
- The unit should be stored in a location where there is minimal activity in order to limit the risk of accidental physical damage.
- To prevent inadvertent operation of the pressure relief devices the unit must not be steam cleaned.
- It is recommended that the unit is periodically inspected during storage.

### INSPECTION

Remove any transit packing and inspect the unit to ensure that all components have been delivered and that no damage has occurred during transit. If any damage is evident, it should be noted on the carrier’s freight bill and a claim entered in accordance with the instructions given on the advice note.

Major damage must be reported immediately to your local Johnson Controls representative.

### MOVING THE CHILLER

Prior to moving the unit, ensure that the installation site is suitable for installing the unit and is easily capable of supporting the weight of the unit and all associated services.



***The unit must only be lifted by the base frame at the points provided. Never move the unit on rollers, or lift the unit using a forklift truck.***

Care should be taken to avoid damaging the condenser cooling fins when moving the unit.

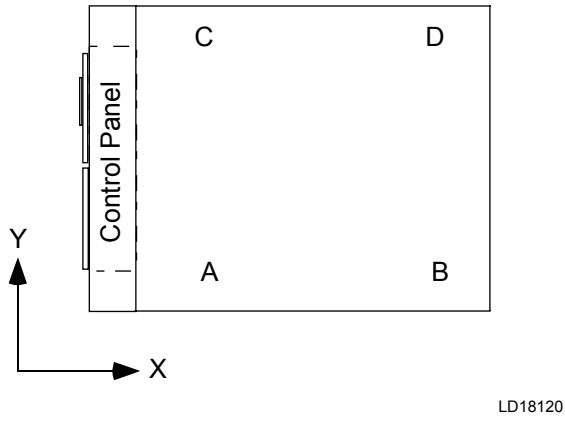

**4 Fan Units**

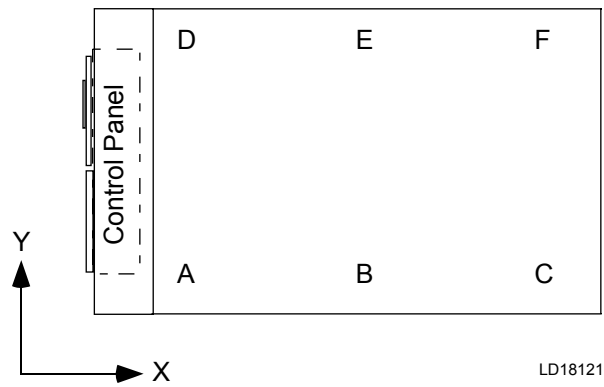

**5 - 12 Fan Units**

**FIGURE 6 - UNIT RIGGING/LIFTING**

### LIFTING USING LUGS

Units are provided with lifting holes in the base frame which accept the accessory lifting lug set as shown in the figure below. The lugs (RH and LH) should be inserted into the respective holes in the base frame and turned so that the spring loaded pin engages into the hole and the flanges on the lug lock behind the hole. The lugs should be attached to the cables/chains using shackles or safety hooks.

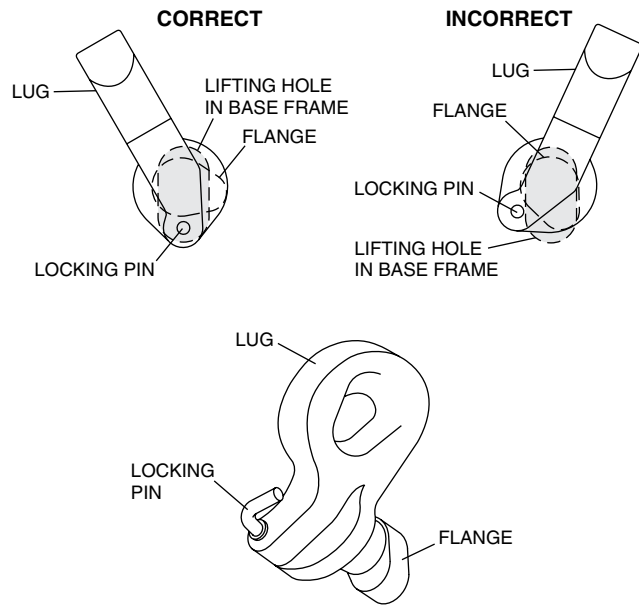

### LIFTING USING SHACKLES

The shackles should be inserted into the respective holes in the base frame and secured from the inside.

Use spreader bars to avoid lifting chains hitting the chiller. Various methods of spreader bar arrangements may be used, keeping in mind the intent is to keep the unit stable and to keep the chains from hitting the chiller and causing damage.

Lifting Instructions are placed on a label on the chiller and on the shipping bag.



# WARNING

**Failure to follow these instructions could result in death, serious injury or equipment damage.**

**Follow all warnings and instructions in the unit's Manual(s).**

<p><b>EN</b> Installation Instructions for the technician / fitter</p> <p><b>PL</b> Instrukcja instalacji dla technika / monter</p> <p><b>SV</b> Installationsguide för installatör / montör</p> <p><b>CS</b> Pokyny k instalaci pro techniky a montéry</p>	<p><b>IT</b> Istruzioni d'installazione per il personale specializzato</p> <p><b>NL</b> Installatiehandleiding voor de vakman / monteur</p> <p><b>DE</b> Installationsanleitung für die Fachkraft / Monteur</p> <p><b>ES</b> Instrucciones de instalación para el técnico / contratista especializado</p>	<p><b>JA</b> 一般仕様・取扱説明書</p> <p><b>FR</b> Manuel d'installation pour le spécialiste / monteur</p> <p><b>RU</b> Инструкция по установке для техника/монтажника</p> <p><b>ZH</b> 适用于技术人员与安装人员的 安装说明书</p>
---	---	---



1. Follow all applicable regulations and safety practices during rigging and lifting.
2. Prepare and follow written rigging and lifting plan.
3. Rigging must be directed by trained professional rigger.
4. Spreader bars must be used and be long enough to prevent rigging from contacting unit.
5. Use all and only designated lift points according to units manual(s).
6. Locate center of gravity through trial lifts to account for possible variations in unit configuration.
7. Use rigging and lifting techniques that keep unit stable and level.
8. Keep clear of unit when lifted.

035-23962-000 REV A

LD18119

FIGURE 7 - WARNING



*Rigging and lifting should only be done by a professional rigger in accordance with a written rigging and lifting plan. The most appropriate rigging and lifting method will depend on job specific factors, such as the rigging equipment available and site needs. Therefore a professional rigger must determine the rigging and lifting method to be used and it is beyond the scope of the manual to specify rigging and lifting details.*

## LIFTING WEIGHTS

See the unit nameplate for unit shipping weight. Note that weight may vary depending on unit configuration at the time of lifting. See page 50 for further information regarding shipping and operating weights.

## SECTION 4 – INSTALLATION



***To ensure warranty coverage, this equipment must be commissioned and serviced by an authorized Johnson Controls service mechanic or a qualified service person experienced in chiller installation. Installation must comply with all applicable codes, particularly in regard to electrical wiring and other safety elements such as relief valves, HP cutout settings, design working pressures, and ventilation requirements consistent with the amount and type of refrigerant charge.***

***Lethal voltages exist within the control panels. Before servicing, open and tag all disconnect switches.***

### INSTALLATION CHECKLIST

The following items, 1 through 6, must be checked before placing the units in operation.

1. Inspect the unit for shipping damage.
2. Rig unit using spreader bars.
3. Open the unit only to install water piping system. Do not remove protective covers from water connections until piping is ready for attachment. Check water piping to ensure cleanliness.
4. Pipe unit using good piping practice (see ASHRAE handbook section 215 and 195).
5. Check to see that wiring is tight and meets NEC and local codes.
6. Check to see that the unit is installed and operated within limitations (See *Operational Limitations (English)* on page 43).

### STARTUP/COMMISSIONING

The following pages outline detailed procedures to be followed to install and start-up the chiller.

### LOCATION AND CLEARANCES

Units are designed for outdoor installations on ground level, rooftop, or beside a building. Location should be selected for minimum sun exposure and to insure adequate supply of fresh air for the condenser. The units must be installed with sufficient clearances for air entrance to the condenser coil, for air discharge away from the condenser, and for servicing access.

In installations where winter operation is intended and snow accumulations are expected, additional height must be provided to ensure normal condenser air flow.

Clearances are listed in *Figure 32* on page 88.

### Foundation

The unit should be mounted on a flat and level foundation, floor, or rooftop capable of supporting the entire operating weight of the equipment. See *Physical Data YLAA0058 – YLAA0230 60Hz* on page 46 for operating weight. If the unit is elevated beyond the normal reach of service personnel, a suitable catwalk must be capable of supporting service personnel, their equipment, and the compressors.

### Ground Level Locations

It is important that the units be installed on a substantial base that will not settle. A one piece concrete slab with footers extended below the frost line is highly recommended. Additionally, the slab should not be tied to the main building foundations as noise and vibration may be transmitted. Mounting holes (5/8" dia.) are provided in the steel channel for bolting the unit to its foundation (see *Dimensions* on page 35).

For ground level installations, precautions should be taken to protect the unit from tampering by or injury to unauthorized persons. Screws and/or latches on access panels will prevent casual tampering. However, further safety precautions such as a fenced-in enclosure or locking devices on the panels may be advisable.

### Rooftop Locations

Choose a spot with adequate structural strength to safely support the entire weight of the unit and service personnel. Care must be taken not to damage the roof.

Consult the building contractor or architect if the roof is bonded. Roof installations should have wooden beams (treated to reduce deterioration), cork, rubber, or spring type vibration isolators under the base to minimize vibration.

### Noise Sensitive Locations

Efforts should be made to assure that the chiller is not located next to occupied spaces or noise sensitive areas where chiller noise level would be a problem. Chiller noise is a result of compressor and fan operation.

## SPRING ISOLATORS (OPTIONAL)

When ordered, isolators will be furnished. Identify the isolator, locate at the proper mounting point, and adjust per instructions.

## COMPRESSOR MOUNTING

The compressors are mounted on four (4) rubber isolators. The mounting bolts should not be loosened or adjusted at installation of the chiller.

## REMOTE COOLER OPTION

Not available at this time.

## CHILLED LIQUID PIPING

**General** – When the unit(s) has been located in its final position, the unit water piping may be connected. Normal installation precautions should be observed in order to receive maximum operating efficiencies. Piping should be kept free of all foreign matter. All chilled water evaporator piping must comply in all respects with local plumbing codes and ordinances.

Since elbows, tees and valves decrease pump capacity, all piping should be kept as straight and as simple as possible. **All piping must be supported independent of the chiller.**

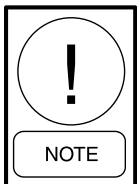

*Consideration should be given to compressor access when laying out water piping. Routing the water piping too close to the unit could make compressor servicing/replacement difficult.*

Hand stop valves should be installed in all lines to facilitate servicing.

Piping to the inlet and outlet connections of the chiller should include high-pressure rubber hose or piping loops to ensure against transmission of water pump vibration. The necessary components must be obtained in the field.

Drain connections should be provided at all low points to permit complete drainage of the cooler and system water piping.

A small valve or valves should be installed at the highest point or points in the chilled water piping to allow any trapped air to be purged. Vent and drain connections should be extended beyond the insulation to make them accessible.

The piping to and from the cooler must be designed to suit the individual installation. It is important that the following considerations be observed:

1. The chilled liquid piping system should be laid out so that the circulating pump discharges directly into the cooler. The suction for this pump should be taken from the piping system return line and not the cooler. This piping scheme is recommended, but is not mandatory.
2. The inlet and outlet cooler connection sizes are provided in *Table 5 on page 46* (Physical Data).
3. A 1/16" mesh strainer is provided at the cooler inlet line just ahead of the cooler. This is important to protect the cooler from entrance of large particles which could cause damage to the evaporator.
4. All chilled liquid piping should be thoroughly flushed to free it from foreign material before the system is placed into operation. Use care not to flush any foreign material into or through the cooler.
5. As an aid to servicing, thermometers and pressure gauges should be installed in the inlet and outlet water lines.
6. The chilled water lines that are exposed to outdoor ambients should be wrapped with supplemental heater cable and insulated to protect against freeze-up during low ambient periods, and to prevent formation of condensation on lines in warm humid locations. As an alternative, ethylene glycol should be added to protect against freeze-up during low ambient periods.
7. A chilled water flow switch, (either by YORK or others) **MUST** be installed in the leaving water piping of the cooler. If the factory wired flow switch and extension pipe kit is not selected, the field installed flow switch must be installed so that there is a straight horizontal run of at least 5 diameters on each side of the switch. Adjust the flow switch paddle to the size of the pipe in which it is to be installed (see manufacturer's instructions furnished with the switch). The switch is to be wired to Terminals 13 and 14 of XTBC1 located in the control panel, as shown on the unit wiring diagram.



*The Flow Switch **MUST NOT** be used to start and stop the chiller (i.e. starting and stopping the chilled water pump). It is intended only as a safety switch.*

## PIPEWORK ARRANGEMENT

The following are suggested pipework arrangements for single unit installations, for multiple unit installations, each unit should be piped as shown.

### Recommendations of the Building Services Research Association.

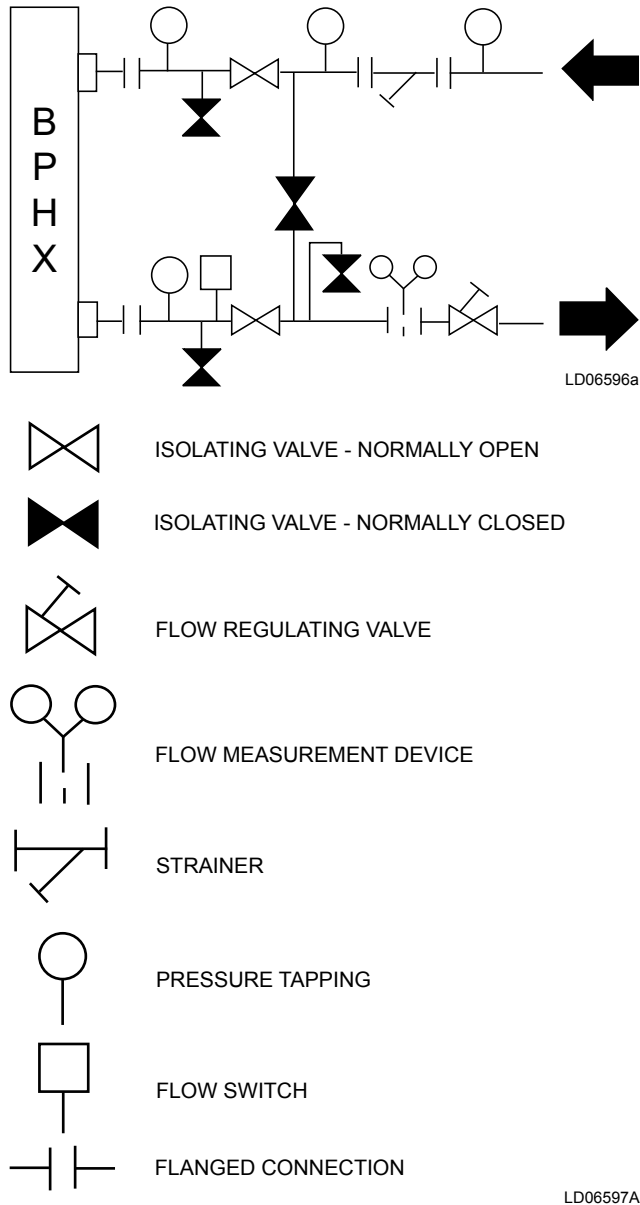

**FIGURE 8 - CHILLED LIQUID SYSTEM**

### Fan Discharge Ducting

The following duct work recommendations are intended to ensure satisfactory operation of the unit. Failure to follow these recommendations could cause damage to the unit, or loss of performance, and may invalidate the warranty.

When ducting is to be fitted to the fan discharge it is recommended that the duct should be the same cross-sectional area as the fan outlet and straight for at least three feet (1 meter) to obtain static regain from the fan. Duct work should be suspended with flexible hangers to prevent noise and vibration being transmitted to the structure. A flexible joint is also recommended between the duct attached to the fan and the next section for the same reason. Flexible connectors should not be allowed to concertina.

The unit is not designed to take structural loading. No significant amount of weight should be allowed to rest on the fan outlet flange, deck assemblies or condenser coil module. No more than 3 feet (1 meter) of light construction duct work should be supported by the unit. Where cross winds may occur, any duct work must be supported to prevent side loading on the unit.

If the ducts from two or more fans are to be combined into a common duct, back-flow dampers should be fitted in the individual fan ducts. This will prevent recirculation of air when only one of the fans is running.

Units are supplied with outlet guards for safety and to prevent damage to the fan blades. If these guards are removed to fit duct work, adequate alternative precautions must be taken to ensure persons cannot be harmed or put at risk from rotating fan blades.

### WIRING

Liquid Chillers are shipped with all factory-mounted controls wired for operation.

**Field Wiring** – Power wiring must be provided through a fused disconnect switch to the unit terminals (or optional molded disconnect switch) in accordance with N.E.C. or local code requirements. Minimum circuit ampacity and maximum dual element fuse size are given in the Electrical Data tables.

Copper power wiring only should be used for supplying power to the chiller. This is recommended to avoid safety and reliability issues resulting from connection failure at the power connections to the chiller. Aluminum wiring is not recommended due to thermal characteristics that may cause loose terminations resulting from the contraction and expansion of the wiring. Aluminum oxide may also build up at the termination causing hot spots and eventual failure. If aluminum wiring is used to supply power to the chiller, AL-CU compression fittings should be used to transition from

aluminum to copper. This transition should be done in an external box separate to the power panel. Copper conductors can then be run from the box to the chiller.

A 120-1-60, 15 amp source must be supplied for the control panel through a fused disconnect when a control panel transformer (optional) is not provided (See *Figure 9 on page 39*).

See unit wiring diagrams for field and power wiring connections, chilled water pump starter contacts, alarm contacts, compressor run status contacts, PWM input, and load limit input. See *SECTION 8 – UNIT OPERATION* for a detailed description of operation concerning aforementioned contacts and inputs.

## RELIEF VALVES

Relief valves are located on both the high and low pressure side of the piping. High side relief valve pressure setting is 650 PSIG. Low side relief valve pressure setting is 450 PSIG.

## HIGH PRESSURE CUTOUT

A high pressure cutout is installed in the discharge piping of each system. The cutout opens at 585 PSIG plus or minus 10 PSIG and closes at 440 PSIG plus or minus 25 PSIG.

## Evaporator Pump Start Contacts

Terminal block XTBC2 – Terminals 23 (115VAC) to 24, are normally- open contacts that can be used to switch field supplied power to provide a start signal to the evaporator pump contactor. The contacts will be closed when any of the following conditions occur:

1. Low Leaving Chilled Liquid Fault
2. Any compressor is running
3. Daily schedule is not programmed OFF and the Unit Switch is ON

The pump will not run if the micro panel has been powered up for less than 30 seconds, or if the pump has run in the last 30 seconds, to prevent pump motor overheating. See *Figure 13 on page 42* and unit wiring diagram.

## System Run Contacts

Contacts are available to monitor system status. Normally-open auxiliary contacts from each compressor contactor are wired in parallel with XTBC2 – Terminals 25 to 26 for system 1, and XTBC2 – Terminals 27 to 28 for system 2. See *Figure 4 on page 23*, *Figure 13 on page 42* and unit wiring diagram.

## Alarm Status Contacts

Normally-open contacts are available for each refrigerant system. These normally-open contacts close when the system is functioning normally. The respective contacts will open when the unit is shut down on a unit fault, or locked out on a system fault. Field connections are at XTBC2 - Terminals 29 to 30 (system 1), and Terminals 31 to 32 (system 2).

## Remote Start/Stop Contacts

To remotely start and stop the chiller, dry contacts can be wired across terminals 13 and 51 on XTBC1. See *Figure 4 on page 23*, *Figure 10 on page 40* and unit wiring diagram.

## Remote Emergency Cutoff

Immediate shutdown of the chiller can be accomplished by opening a field-installed dry contact to break the electrical circuit between Terminals 5 to L on terminal block XTBC2 . The unit is shipped with a factory jumper installed between Terminals 5 to L, which must be removed if emergency shutdown contacts are installed. See *Figure 10 on page 40* and unit wiring diagram.

## Remote Temp Reset Input

The Remote Temp Reset input allows reset of the chilled liquid setpoint by supplying a voltage or current signal field wiring should be connected to XTBC1 – Terminals A+ to A-. A detailed explanation is provided in *SECTION 7 – UNIT CONTROLS*. See *Figure 3 on page 22*, *Figure 4 on page 23* and unit wiring diagram.

## Load Limit Input

Load limiting is a feature that prevents the unit from loading beyond a desired value. The unit can be “load limited” either 33%, 40%, 50%, 66% or 80%, depending on the number of compressors on unit. The field connections are wired to XTBC1 – Terminals 13 to 21, and work in conjunction with the PWM inputs. A detailed explanation is provided in *SECTION 7 – UNIT CONTROLS*. See *Figure 4 on page 23*, *Figure 10 on page 40* and unit wiring diagram.

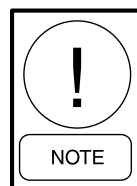

***When using the Load Limit feature, the PWM feature will not function – SIMULTANEOUS OPERATION OF LOAD LIMITING AND TEMPERATURE RESET (PWM INPUT) CANNOT BE DONE.***

**SINGLE-POINT SUPPLY CONNECTION – TERMINAL BLOCK, NON-FUSED DISCONNECT SWITCH OR CIRCUIT BREAKER**

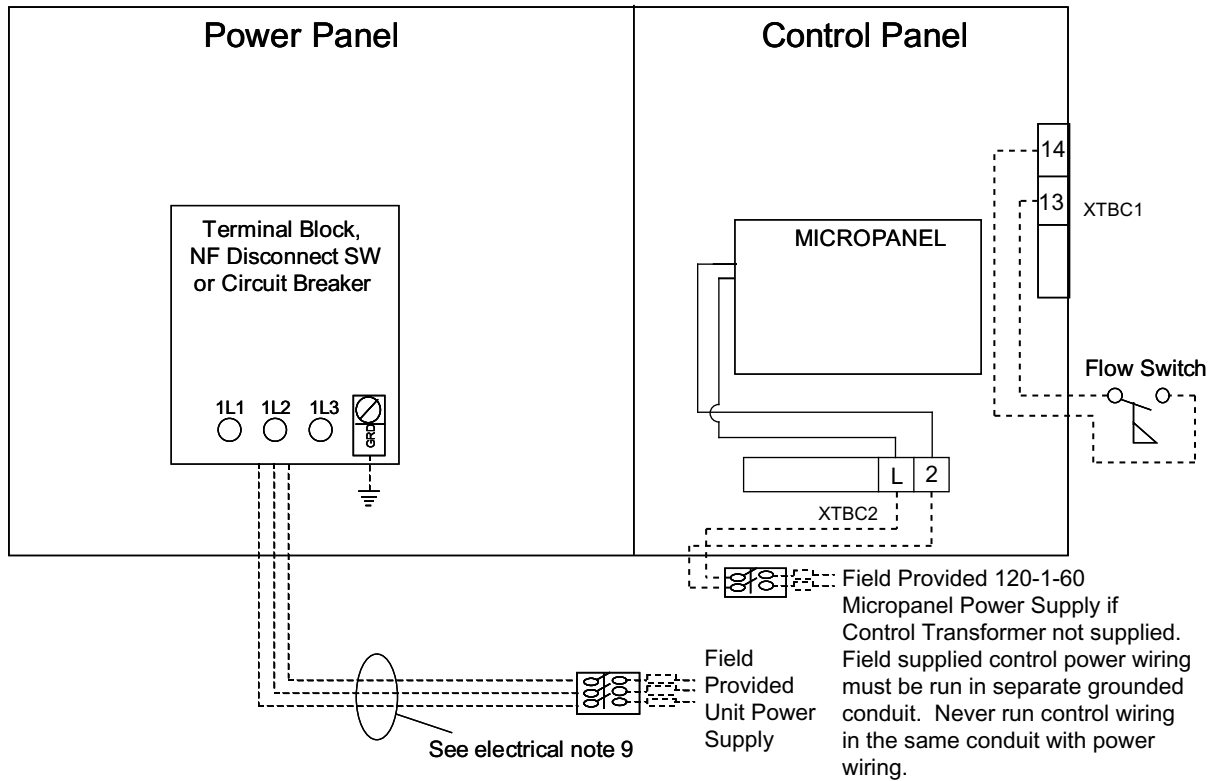

**4**



*It is possible that multiple sources of power can be supplying the unit power panel. To prevent serious injury or death, the technician should verify that **NO LETHAL VOLTAGES** are present inside the panel **AFTER** disconnecting power, **PRIOR** to working on equipment.*

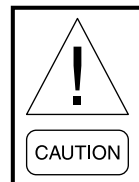

*The unit evaporator heater uses 120VAC. Disconnecting 120VAC power from the unit, at or below freezing temperatures, can result in damage to the evaporator and unit as a result of the chilled liquid freezing.*

LD13141

**FIGURE 9 - SINGLE-POINT SUPPLY CONNECTION – TERMINAL BLOCK, NON-FUSED DISCONNECT SWITCH OR CIRCUIT BREAKER**

## USER CONTROL WIRING INPUTS

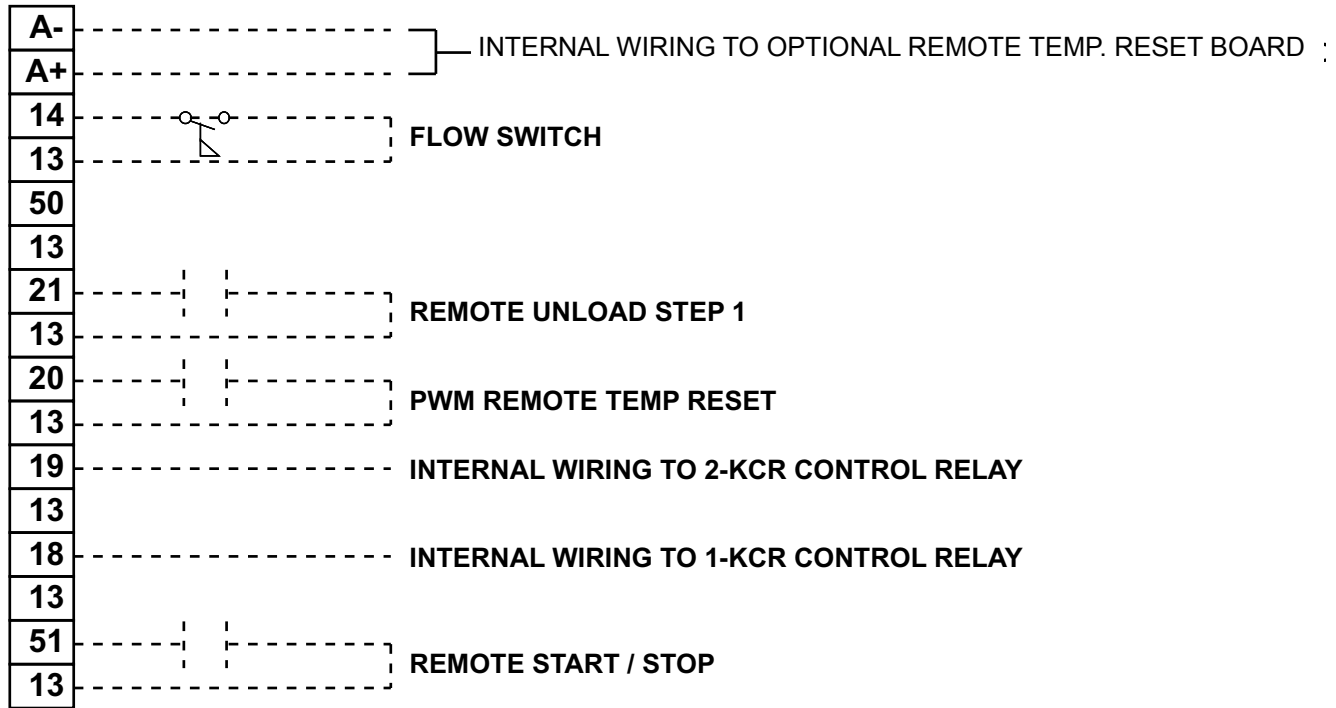

XTBC1

LD13130

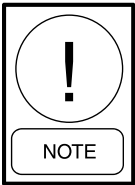

*All externally supplied contacts must be capable of switching 24VDC / 115 VAC. Gold contacts are recommended. If supplied contacts are from a Relay / Contactor (Inductive Load), the coil of the Relay / Contactor must be suppressed. Typical suppressor is P/N 031-00808-000.*

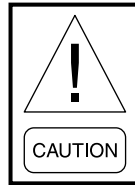

*The unit evaporator heater uses 120VAC. Disconnecting 120VAC power from the unit, at or below freezing temperatures, can result in damage to the evaporator and unit as a result of the chilled liquid freezing.*



*It is possible that multiple sources of power can be supplying the unit power panel. To prevent serious injury or death, the technician should verify that **NO LETHAL VOLTAGES** are present inside the panel **AFTER** disconnecting power, **PRIOR** to working on equipment.*

FIGURE 10 - CONTROL WIRING INPUTS

### Thermal Dispersion Flow Switch:

#### 1. Thermal Dispersion Flow Switch Operating Principle

The operating principle of the thermal dispersion flow switch is based on the calorimetric principle. It uses the cooling effect of a flowing fluid to monitor the flow rate. The amount of thermal energy that is removed from the tip determines the local flow rate. This temperature-based operating principle can reliably sense the flow of virtually any liquid or gas.

The sensor tip of the thermal dispersion flow sensor houses two transistors and a heater element. One transistor is located in the sensor tip, closest to the flowing fluid. This transistor is used to detect changes in the flow velocity of the liquid. The second transistor is bonded to the cylindrical wall and is a reference for ambient fluid conditions.

In order to make the sensor sense flow, it is necessary to heat one of the transistors in the probe. When power is applied, the tip of the probe is heated. As the fluid starts to flow, heat will be carried away from the sensor tip. Cooling of the first transistor is a function of how fast heat is conducted away by the flowing liquid. The difference in temperature between the two transistors provides a measurement of fluid velocity past the sensor probe. When fluid velocity is high, the temperature differential is small. As fluid velocity decreases, there is an increase in the temperature differential.

#### 2. Service Information

The P/N of the thermal dispersion switch is 025-43553-000, SAP # is 618247. you can purchase it from JCI part center through JCI service office close to your site.

The connection of thermal dispersion switch is 1/4" NPT, so when replacing a flow switch with different connection size, the connector on the liquid system need to replace as well so that it can adapt to the thermal dispersion flow switch.

#### 3. Wiring of Thermal Dispersion Flow Switch

- a. The wire connection of thermal dispersion switch contains 5 pins, the central pin is Pin #5 used for programming, which is unnecessary for wiring. (See *Figure 12 on page 41*)

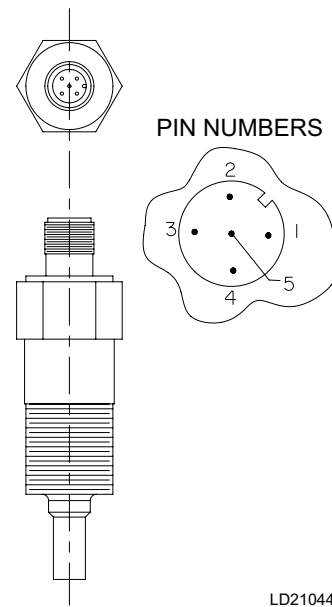

LD21044

**FIGURE 11 - THERMAL DISPERSION FLOW SWITCH**

- b. Pin #1 and Pin #3 are used to connect with 24V AC from transformer T1 by terminal #40 and 41. (see the red dot line frame in *Figure 14 on page 60*)
- c. Pin #2 and Pin #4 are used to output the status of thermal dispersion flow switch, these 2 pins need to be connected with terminal #13 and #14 of XTBC1 as *Figure 10 on page 40* indicated.

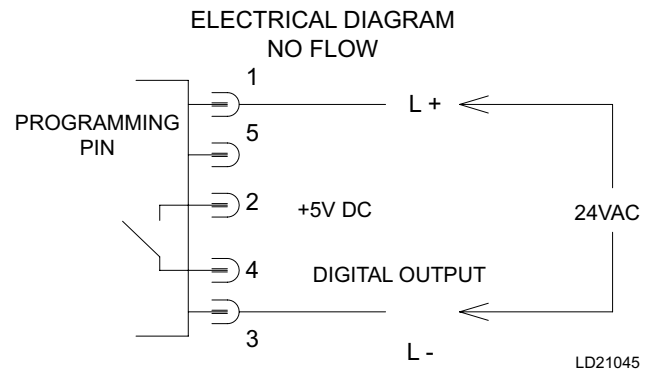

LD21045

**FIGURE 12 - THERMAL DISPERSION FLOW SWITCH (COMBINE TOGETHER)**

## USER CONTROL WIRING OUTPUTS

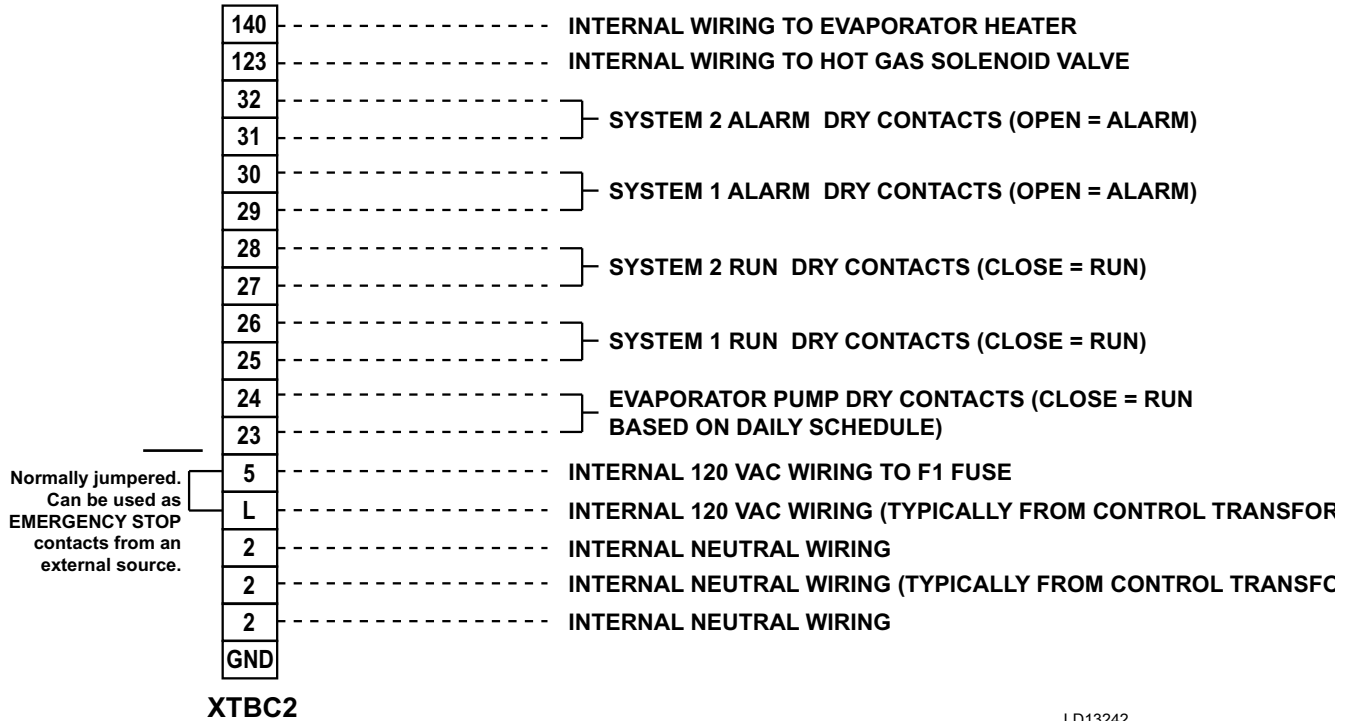

LD13242

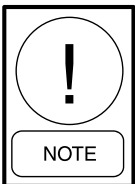

*All chiller supplied contacts are rated at 115VAC, 100VA, resistive load only, and must be suppressed at the load by user if powering an inductive load (Relay / Contactor Coil). Typical suppressor P/N is 031-00808-000.*



*It is possible that multiple sources of power can be supplying the unit power panel. To prevent serious injury or death, the technician should verify that NO LETHAL VOLTAGES are present inside the panel AFTER disconnecting power, PRIOR to working on equipment.*



*The unit evaporator heater uses 120VAC. Disconnecting 120VAC power from the unit, at or below freezing temperatures, can result in damage to the evaporator and unit as a result of the chilled liquid freezing.*

FIGURE 13 - CONTROL WIRING OUTPUTS

## SECTION 5 – TECHNICAL DATA

### OPERATIONAL LIMITATIONS (ENGLISH)

**TABLE 3 - TEMPERATURES AND FLOWS**

UNIT DESIGNATION	TEMPERATURE		WATER FLOW (GPM) MIN	WATER FLOW (GPM) MAX	AIR ON CONDENSER (°F)	
	MIN <sup>1</sup>	MAX <sup>2</sup>			MIN <sup>3</sup>	MAX <sup>4</sup>
<b>STANDARD EFFICIENCY</b>						
YLAA0070SE	40	55	60	325	0	125
YLAA0080SE	40	55	100	350	0	125
YLAA0089SE	40	55	100	400	0	125
YLAA0100SE	40	55	100	400	0	125
YLAA0120SE	40	55	150	625	0	125
YLAA0136SE	40	55	115	530	0	125
YLAA0155SE	40	55	150	625	0	125
YLAA0170SE	40	55	138	525	0	125
<b>HIGH EFFICIENCY</b>						
YLAA0058HE	40	55	60	325	0	125
YLAA0065HE	40	55	60	325	0	125
YLAA0081HE	40	55	115	530	0	125
YLAA0092HE	40	55	100	400	0	125
YLAA0101HE	40	55	100	400	0	125
YLAA0125HE	40	55	100	400	0	125
YLAA0142HE	40	55	150	530	0	125
YLAA0156HE	40	55	138	525	0	125
YLAA0175HE	40	55	200	650	0	125
YLAA0200HE	40	55	230	625	0	125
YLAA0230HE	40	55	220	625	0	125

**NOTES:**

1. For leaving liquid temperature below 40°F (4°C) (to 10°F [-12°C]) optional low temperature glycol kit required. Contact your nearest Johnson Controls Office for application requirements.
2. For leaving liquid temperature higher than 55°F (13°C), contact the nearest Johnson Controls Office for application guidelines.
3. The evaporator is protected against freezing to -20°F (-29°C) with an electric heater as standard.
4. For operation at temperatures above 115°F (46°C), the optional High Ambient Kit will need to be installed on the system.



*Excessive flow will cause damage to the cooler. Do not exceed maximum cooler flow. Special care should be taken when multiple chillers are fed by a single pump.*

## HEAT EXCHANGER FLOW, GPM

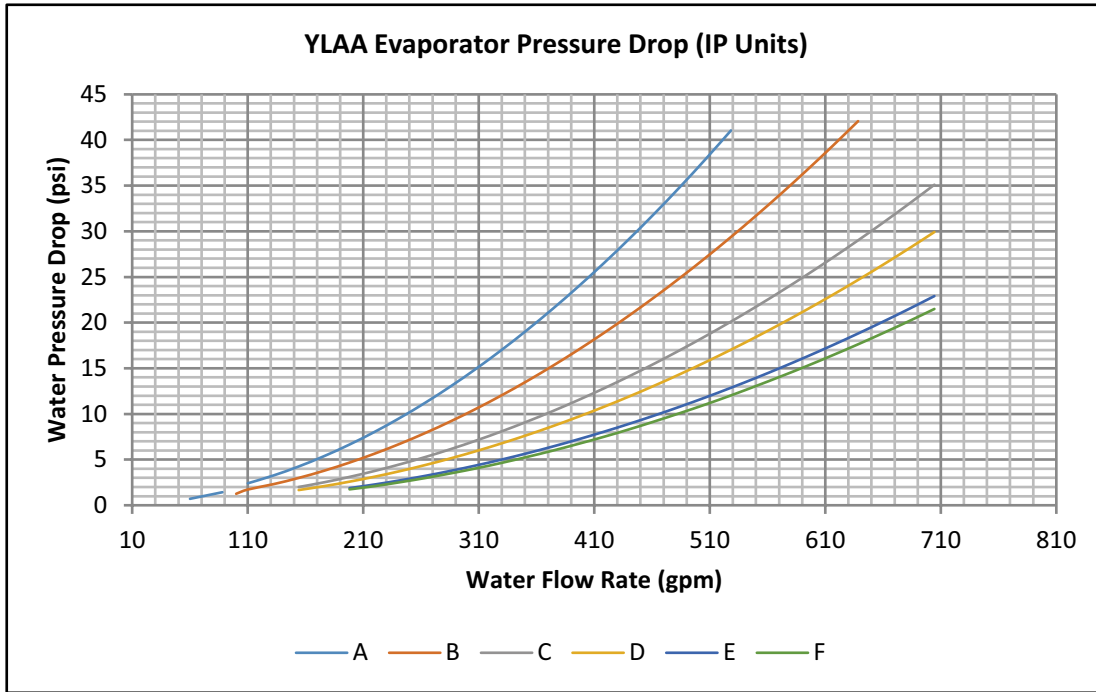

LD21182

EVAPORATOR	YLAA MODELS
A	0058HE, 0065HE, 0070SE
B	0080SE
C	0089SE, 0100SE, 0092HE, 0101HE, 0125HE
D	0081HE, 0136SE, 0170SE, 0156HE
E	0120SE, 0155SE, 0142HE
F	0175HE

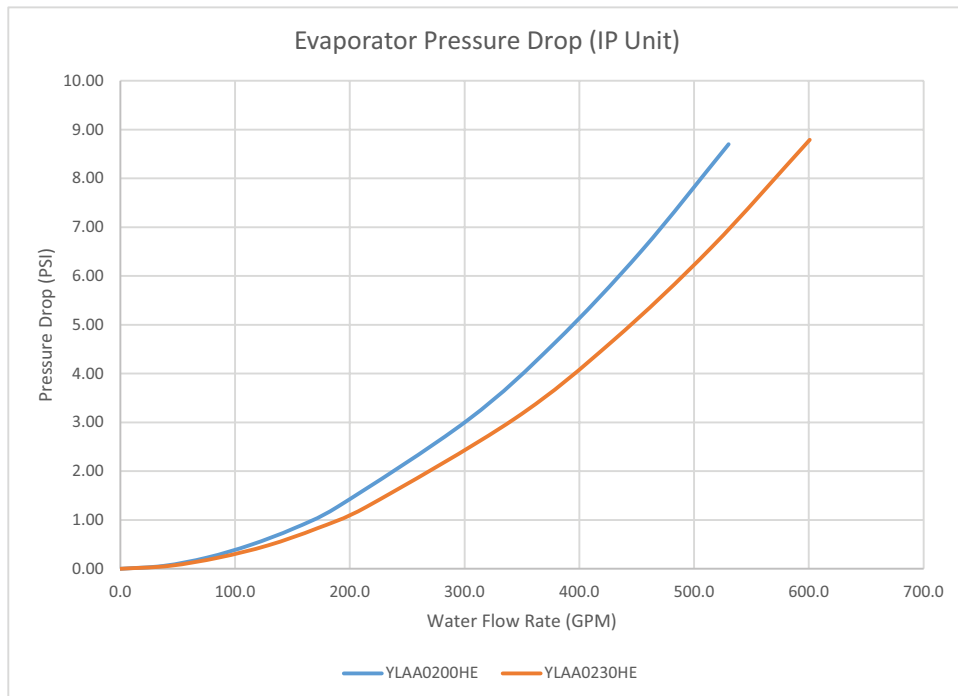

LD21183a

**TABLE 4 - ETHYLENE AND PROPYLENE GLYCOL CORRECTION FACTORS**

ETHYLENE GLYCOL						PROPYLENE GLYCOL					
% WEIGHT	TONS	COMPR KW	GPM F/ TON	PRESS DROP	FREEZE PT	% WEIGHT	TONS	COMPR KW	GPM F/ TON	PRESS DROP	FREEZE PT
10.0	1.0	1.0	24.3	1.0	26.2	10.0	1.0	1.0	24.0	1.0	26.0
20.0	1.0	1.0	25.1	1.1	17.9	20.0	1.0	1.0	24.3	1.1	19.0
30.0	1.0	1.0	25.9	1.2	6.7	30.0	1.0	1.0	24.9	1.3	9.0
40.0	1.0	1.0	26.9	1.4	-8.1	40.0	1.0	1.0	25.6	1.4	-6.0
50.0	1.0	1.0	28.0	1.6	-28.9	50.0	0.9	1.0	26.6	1.7	-28.0

**NOTE:** Water Pressure Drop Curves may extend past the minimum and maximum water flow ranges.

**PHYSICAL DATA YLAA0058 – YLAA0230 60HZ****TABLE 5 - PHYSICAL DATA (ENGLISH) 60 HZ**

REFRIGERANT R-410A	YLAA							
	STANDARD EFFICIENCY UNITS							
	0070SE	0080SE	0089SE	0100SE	0120SE	0136SE	0155SE	0170SE
<b>NOMINAL RATINGS<sup>3</sup></b>								
TONS	71.0	77.8	81.8	95.6	118.1	126.1	143.0	167.4
KW INPUT	77.5	86.3	93.0	111.5	134.6	142.6	165.0	192.1
EER	10.4	10.0	9.8	9.7	9.8	9.7	9.7	9.7
IPLV	16.1	15.6	15.8	14.5	15.0	15.8	15.8	15.6
<b>GENERAL UNIT DATA</b>								
Length	116.1	116.1	116.1	142.7	142.7	187.7	187.7	232.7
Width	88	88	88	88	88	88	88	88
Height	94.2	94.2	94.2	94.2	94	94.2	94.2	94.2
Number Of Refrigerant Circuits	2	2	2	2	2	2	2	2
<b>REFRIGERANT CHARGE, OPERATING</b>								
R-410A, CKT1/CKT2, LBS	43/43	47/44	57/57	55/58	54/62	75/71	75/70	90/87
Oil Charge, CKT1/CKT2, Gallons	2.58/2.58	3.28/2.58	3.28/2.76	3.28/3.33	3.33/3.33	4.99/2.76	4.99/3.33	4.99/4.99
Shipping Weight	3578	3898	4168	4791	5183	6148	6414	7734
Operating Weight	3623	3954	4241	4864	5293	6232	6524	7818
<b>COMPRESSORS, SCROLL TYPE</b>								
Compressors Per Circuit	3/3	3/3	3/3	3/2	3/2	3/3	3/2	3/3
Compressors Per Unit	6	6	6	5	4	6	5	6
<b>NOMINAL TONS PER COMPRESSOR</b>								
Circuit 1	13	15	15	15	32	32	32	32
Circuit 2	13	13	15	32	32	15	32	32
<b>CONDENSER</b>								
Total Face Area Ft <sup>2</sup>	106.9	106.9	106.9	133.6	160.3	213.8	213.8	267.2
Number Of Rows	1	1	1	1	1	1	1	1
Fins Per Inch	20	20	20	20	20	20	20	20
<b>CONDENSER FANS, LOW SOUND</b>								
Number Of Fans, CKT 1/CKT 2	2/2	2/2	2/2	3/2	3/3	4/4	4/4	5/5
Fan HP	2	2	2	2	2	2	2	2
Fan RPM	1160	1160	1160	1160	1160	1160	1160	1160
Total Chiller CFM	62400	62400	62400	78000	93600	124800	124800	156000
<b>EVAPORATOR</b>								
Water Volume, Gallons	5.4	6.7	8.8	8.8	13.2	10.0	13.2	10.0
Maximum Water Side Pressure, PSIG	150	150	150	150	150	150	150	150
Maximum Refrigerant Side Pressure, PSIG	450	450	450	450	450	450	450	450
Minimum Chiller Water Flow Rate, GPM	60	100	140	100	150	150	150	150
Maximum Chiller Water Flow Rate, GPM	285	355	385	385	625	625	625	625
Water Connections Size, Inches	3	3	3	3	3	4*	4*	4*

**NOTES:**

1. kW = Compressor Input Power.
2. EER = Chiller EER (includes power from compressors, fans, and the control panels 0.8 kW).
3. Rated in accordance with AHRI Standard 550/590 at an air on condenser temperature of 95°F and a leaving chilled water temperature of 44°F.
4. Additional rating information can be provided by your local Johnson Controls Sales Office.

**TABLE 5 - PHYSICAL DATA (ENGLISH) 60 HZ (CONT'D)**

REFRIGERANT R-410A	YLAA										
	HIGH EFFICIENCY UNITS										
	0058HE	0065HE	0081HE	0092HE	0101HE	0125HE	0142HE	0156HE	0175HE	0200HE	0230HE
<b>NOMINAL RATINGS<sup>3</sup></b>											
TONS	57.0	62.3	78.8	85.7	98.3	116.0	129.5	144.5	172.5	194.5	220.6
KW INPUT	64.4	71.9	91.0	83.6	106.1	122.0	138.9	153.0	194.2	210.9	240.0
EER	10.6	10.4	10.4	11.0	10.1	10.3	10.2	10.2	9.8	10.1	10.2
IPLV	15.6	15.6	16.1	16.1	15.7	15.7	15.9	15.5	15.6	16.1	15.2
<b>GENERAL UNIT DATA</b>											
Length	100.2	100.2	100.2	142.7	142.7	187.7	187.7	232.7	232.7	274.4	274.4
Width	88.0	88.0	88.0	88	88	88	88	88	88	88.3	88.3
Height	94.2	94.2	94.2	94.2	94.2	94.2	94.2	94.2	94.2	94.2	94.2
Number Of Refrigerant Circuits	2	2	2	2	2	2	2	2	2	2	2
<b>REFRIGERANT CHARGE, OPERATING</b>											
R-410A, CKT1/CKT2, LBS	43/43	43/43	44/44	59/55	45/65	75/71	83/73	90/82	94/92	95/95	100/100
Oil Charge, CKT1/CKT2, Gallons	2.58/2.58	2.89/2.58	2.58/2.58	2.76/2.76	3.28/3.33	3.33/3.33	4.99/2.76	4.99/3.33	4.99/4.99	4.2/4.2	4.99/4.99
Shipping Weight	3508	3704	4061	4718	4953	5869	6259	7344	7882	9205	9690
Operating Weight	3552	3748	4145	4791	5026	5942	6369	7428	8001	9333	9821
<b>COMPRESSORS, SCROLL TYPE</b>											
Compressors Per Circuit	2/2	3/2	3/3	3/3	3/2	2/2	3/3	3/2	3/3	3/3	3/3
Compressors Per Unit	4	5	6	6	5	4	6	5	6	6	6
<b>NOMINAL TONS PER COMPRESSOR</b>											
Circuit 1	15	13	15	15	15	32	32	32	32	35	40
Circuit 2	15	15	13	15	32	32	15	32	32	35	40
<b>CONDENSER</b>											
Total Face Area Ft <sup>2</sup>	106.9	106.9	106.9	160.3	160.3	213.8	213.8	267.2	267.2	320	320.7
Number Of Rows	1	1	1	1	1	1	1	1	1	1	1
Fins Per Inch	20	20	20	20	20	20	20	20	20	20	20
<b>CONDENSER FANS, LOW SOUND</b>											
Number Of Fans, CKT 1/ CKT 2	2/2	2/2	2/2	3/3	4/2	4/4	5/3	6/4	5/5	6/6	6/6
Fan HP	2	2	2	2	2	2	2	2	2	2.0	2.0
Fan RPM	1160	1160	1160	1160	1160	1160	1160	1160	1160	1160	1160
Total Chiller CFM	62400	62400	62400	93600	93600	124800	124800	156000	156000	187200	187200
<b>EVAPORATOR</b>											
Water Volume, Gallons	5.4	5.4	10	8.8	8.8	8.8	13.2	10.0	14.3	12.6	14.3
Maximum Water Side Pressure, PSIG	150	150	150	150	150	150	150	150	150	150	150
Maximum Refrigerant Side Pressure, PSIG	450	450	450	450	450	450	450	450	450	450	450
Minimum Chiller Water Flow Rate, GPM	60	60	150	100	100	100	150	150	150	230	220
Maximum Chiller Water Flow Rate, GPM	285	285	625	385	385	385	625	625	625	625	625
Water Connections Size, Inches	3	3	3	3	3	4*	4*	4*	4*	5	5

**NOTES:**

1. kW = Compressor Input Power.
2. EER = Chiller EER (includes power from compressors, fans, and the control panels 0.8 kW).
3. Rated in accordance with AHRI Standard 550/590 at an air on condenser temperature of 95°F and a leaving chilled water temperature of 44°F.
4. Additional rating information can be provided by your local Johnson Controls Sales Office.

**ELECTRICAL DATA****TABLE 6 - MICROPANEL POWER SUPPLY**

UNIT VOLTAGE	UNIT VOLTAGE	CONTROL POWER	MCA NOTE A	OVER CURRENT PROTECTION, SEE NOTE B		NF DISC SW
				MIN	MAX	
MODELS W/O CONTROL TRANS		115-1-60/50	15A	10A	15A	30 A / 240V
MODELS W/ CONTROL TRANS	-17	200-1-60	15A	10A	15A	30 A / 240V
	-28	230-1-60	15A	10A	15A	30 A / 240V
	-40	380-1-60	15A	10A	15A	30 A / 480V
	-46	460-1-60	15A	10A	15A	30 A / 480V
	-50	380/415-1-60	15A	10A	15A	30A / 415V
	-58	575-1-60	15A	10A	15A	30 A / 600V

A. Minimum #14 AWG, 75 °C, Copper Recommended

B. Minimum and Maximum Over Current Protection, Dual Element Fuse or Circuit Breaker



*It is possible that multiple sources of power can be supplying the unit power panel. To prevent serious injury or death, the technician should verify that **NO LETHAL VOLTAGES** are present inside the panel **AFTER** disconnecting power, **PRIOR** to working on equipment.*



*The unit evaporator heater uses 120VAC. Disconnecting 120VAC power from the unit, at or below freezing temperatures, can result in damage to the evaporator and unit as a result of the chilled liquid freezing.*

**Voltage Limitations**

The following voltage limitations are absolute and operation beyond these limitations may cause serious damage to the compressor.

**TABLE 7 - VOLTAGE RANGE**

VOLTAGE CODE	UNIT POWER	VOLTAGE RANGE	
		MIN.	MAX.
-17	200/3/60	180	220
	208/3/60	187	228
-28	230-3-60	207	253
-40	380-3-60	355	415
-46	460-3-60	414	506
-50	380/415-3-50	360	440
-58	575-3-60	517	633

**COMPRESSOR HEATERS**

Compressor heaters are standard. ZP180 compressors utilize 70W heaters; ZP235, compressor use 120W heaters and ZP285, ZP385, and ZP485 utilize 150W heaters. If power is OFF more than two hours, the

crankcase heaters must be energized for 18 – 24 hours prior to restarting a compressor. This will assure that liquid slugging and oil dilution does not damage the compressors on start.

**TABLE 8 - PUMP ELECTRICAL DATA (60 HZ)**

PUMP MODEL	HORSE POWER	RPM	PUMP ELECTRICAL DATA									
			208-3-60HZ		230-3-60HZ		380-3-60HZ		460-3-60HZ		575-3-60HZ	
			FLA	LRA	FLA	LRA	FLA	LRA	FLA	LRA	FLA	LRA
<b>A</b>	5	3600	N/A	N/A	12.0	92.0	7.1	55.5	6.0	46.0	4.8	36.8
<b>B</b>	7.5	3600	N/A	N/A	17.6	126.0	10.6	78.0	8.8	63.0	7.0	50.4
<b>C</b>	10	3600	N/A	N/A	23.6	162.0	14.3	102.0	14.0	81.0	9.4	64.8
<b>D</b>	15	3600	N/A	N/A	35.0	232.0	20.9	143.0	17.5	116.0	14.0	92.8
<b>E</b>	5	1800	N/A	N/A	13.0	92.0	7.9	55.5	6.5	46.0	5.2	36.8
<b>F</b>	15	3600	N/A	N/A	35.0	232.0	20.9	143.0	17.5	116.0	14.0	92.8
<b>G</b>	7.5	3600	N/A	N/A	17.6	126.0	10.6	78.0	8.8	63.0	7.0	50.4
<b>H</b>	10	3600	N/A	N/A	23.6	162.0	14.3	102.0	14.0	81.0	9.4	64.8
<b>I</b>	15	3600	N/A	N/A	35.0	232.0	20.9	143.0	17.5	116.0	14.0	92.8
<b>J</b>	5	1800	N/A	N/A	13.0	92.0	7.9	55.5	6.5	46.0	5.2	36.8
<b>K</b>	15	3600	N/A	N/A	35.0	232.0	20.9	143.0	17.5	116.0	14.0	92.8
<b>L</b>	20	3600	N/A	N/A	45.0	290.0	28.7	190.0	22.5	145.0	18.0	116.0
<b>M</b>	3	1800	N/A	N/A	8.0	64.0	4.7	38.0	4.0	32.0	3.2	25.6
<b>N</b>	7.5	3600	N/A	N/A	17.6	126.0	10.6	78.0	8.8	63.0	7.0	50.4
<b>O</b>	10	3600	N/A	N/A	23.6	162.0	14.3	102.0	14.0	81.0	9.4	64.8
<b>P</b>	15	3600	N/A	N/A	35.0	232.0	20.9	143.0	17.5	116.0	14.0	92.8
<b>R</b>	5	1800	N/A	N/A	13.0	92.0	7.9	55.5	6.5	46.0	5.2	36.8
<b>S</b>	10	1800	N/A	N/A	24.0	162.0	15.1	102.0	12.0	81.0	9.6	64.8
<b>T</b>	15	1800	N/A	N/A	36.4	232.0	22.0	143.0	18.2	116.0	14.6	92.8
<b>U</b>	7.5	1800	N/A	N/A	18.4	126.0	11.1	78.0	9.2	63.0	7.4	50.4
<b>V</b>	20	3600	N/A	N/A	45.0	290.0	28.7	190.0	22.5	145.0	18.0	116.0

**NOTE:**

Reference PIN 59 for Pump Model.

Use this table along with Table 9 Electrical Data without Pumps to determine electrical data of the unit plus the pump.

**TABLE 9 - TRANSFORMER LOAD**

VOLT	VA	
	2000	3000
<b>208</b>	9.6	14.4
<b>230</b>	8.7	13.0
<b>380</b>	5.3	7.9
<b>460</b>	4.3	6.5
<b>575</b>	3.5	5.2

**TABLE 10 - ELECTRICAL DATA WITHOUT PUMPS**

CHILLER MODEL	VOLTAGE CODE	MIN CKT. AMPS	MIN N/F DISC SW	MIN DUAL ELEM FUSE & MIN CB	MAX DUAL ELEM FUSE MAX CB
58	208	276	400	300	300
	230	275	400	300	300
	380	149	200	175	175
	460	130	200	150	150
	575	103	150	110	110
65	208	306	400	350	350
	230	305	400	350	350
	380	170	250	200	200
	460	150	200	175	175
	575	112	150	125	125
70	208	334	400	350	350
	230	333	400	350	350
	380	191	250	225	225
	460	169	200	175	175
	575	120	150	125	125
80	208	363	600	400	400
	230	363	600	400	400
	380	201	250	225	225
	460	177	250	200	200
	575	134	200	150	150
81	208	363	400	400	400
	230	363	400	400	400
	380	201	250	225	225
	460	177	250	200	200
	575	134	200	150	150
89	208	391	600	450	450
	230	390	600	450	450
	380	211	250	250	250
	460	184	250	200	200
	575	146	200	150	150
92	208	406	600	450	450
	230	405	600	450	450
	380	220	400	250	250
	460	192	250	225	225
	575	152	200	150	150
100	208	450	600	500	500
	230	449	600	500	500
	380	260	400	300	300
	460	220	400	250	250
	575	175	250	200	200
101	208	458	600	500	500
	230	456	600	500	500
	380	264	400	300	300
	460	224	400	250	250
	575	178	250	200	200
120	208	497	800	600	600
	230	496	800	600	600
	380	300	400	350	350
	460	250	400	300	300
	575	198	250	225	225

**TABLE 10 - ELECTRICAL DATA WITHOUT PUMPS (CONT'D)**

	SYSTEM # 1									SYSTEM # 2								
	COMPR 1		COMPR 2		COMPR 3		STD FLOW FANS			COMPR 1		COMPR 2		COMPR 3		STD FLOW FANS		
	RLA	LRA	RLA	LRA	RLA	LRA	QTY	FLA	LRA	RLA	LRA	RLA	LRA	RLA	LRA	QTY	FLA	LRA
	57.7	284	57.7	284			2	7.6	44	57.7	284	57.7	284			2	7.6	44
	57.7	330	57.7	330			2	7.4	37	57.7	330	57.7	330			2	7.4	37
	30.9	192	30.9	192			2	4.5	23.1	30.9	192	30.9	192			2	4.5	23.1
	26.9	180	26.9	180			2	4	19	26.9	180	26.9	180			2	4	19
	21.5	132	21.5	132			2	2.9	15.3	21.5	132	21.5	132			2	2.9	15.3
	57.7	284	57.7	249			2	7.6	44	57.7	284	57.7	249			2	7.6	44
	57.7	330	57.7	288			2	7.4	37	57.7	330	57.7	288			2	7.4	37
	30.9	192	30.9	139			2	4.5	23.1	30.9	192	30.9	139			2	4.5	23.1
	26.9	180	26.9	180			2	4	19	26.9	180	26.9	180			2	4	19
	21.5	132	21.5	132			2	2.9	15.3	21.5	132	21.5	132			2	2.9	15.3
	48.5	249	48.5	249	48.5	249	2	7.6	44	48.5	249	48.5	249	48.5	249	2	7.6	44
	48.5	249	48.5	249	48.5	249	2	7.4	37	48.5	249	48.5	249	48.5	249	2	7.4	37
	27.6	159	27.6	159	27.6	159	2	4.5	23.1	27.6	159	27.6	159	27.6	159	2	4.5	23.1
	24.4	145	24.4	145	24.4	145	2	4	19	24.4	145	24.4	145	24.4	145	2	4	19
	17.4	109	17.4	109	17.4	109	2	2.9	15.3	17.4	109	17.4	109	17.4	109	2	2.9	15.3
	48.5	249	48.5	249	48.5	249	2	7.6	44	48.5	249	48.5	249	48.5	249	2	7.6	44
	48.5	288	48.5	288	48.5	288	2	7.4	37	48.5	288	48.5	288	48.5	288	2	7.4	37
	27.6	159	27.6	159	27.6	159	2	4.5	23.1	27.6	159	27.6	159	27.6	159	2	4.5	23.1
	24.4	145	24.4	145	24.4	145	2	4	19	24.4	145	24.4	145	24.4	145	2	4	19
	17.4	109	17.4	109	17.4	109	2	2.9	15.3	17.4	109	17.4	109	17.4	109	2	2.9	15.3
	48.5	249	48.5	249	48.5	249	2	7.6	44	48.5	249	48.5	249	48.5	249	2	7.6	44
	48.5	288	48.5	288	48.5	288	2	7.4	37	48.5	288	48.5	288	48.5	288	2	7.4	37
	27.6	159	27.6	159	27.6	159	2	4.5	23.1	27.6	159	27.6	159	27.6	159	2	4.5	23.1
	24.4	145	24.4	145	24.4	145	2	4	19	24.4	145	24.4	145	24.4	145	2	4	19
	17.4	109	17.4	109	17.4	109	2	2.9	15.3	17.4	109	17.4	109	17.4	109	2	2.9	15.3
	57.7	284	57.7	284	57.7	284	2	7.6	44	57.7	284	57.7	284	57.7	284	2	7.6	44
	57.7	330	57.7	330	57.7	330	2	7.4	37	57.7	330	57.7	330	57.7	330	2	7.4	37
	30.9	192	30.9	192	30.9	192	2	4.5	23.1	30.9	192	30.9	192	30.9	192	2	4.5	23.1
	26.9	180	26.9	180	26.9	180	2	4	19	26.9	180	26.9	180	26.9	180	2	4	19
	21.5	132	21.5	132	21.5	132	2	2.9	15.3	21.5	132	21.5	132	21.5	132	2	2.9	15.3
	57.7	284	57.7	284	57.7	284	3	7.6	44	57.7	284	57.7	284	57.7	284	3	7.6	44
	57.7	330	57.7	330	57.7	330	3	7.4	37	57.7	330	57.7	330	57.7	330	3	7.4	37
	30.9	192	30.9	192	30.9	192	3	4.5	23.1	30.9	192	30.9	192	30.9	192	3	4.5	23.1
	26.9	180	26.9	180	26.9	180	3	4	19	26.9	180	26.9	180	26.9	180	3	4	19
	21.5	132	21.5	132	21.5	132	3	2.9	15.3	21.5	132	21.5	132	21.5	132	3	2.9	15.3
	106.2	523	106.2	523			3	7.6	44	106.2	523	106.2	523			3	7.6	44
	106.2	578	106.2	578			3	7.4	37	106.2	578	106.2	578			3	7.4	37
	64.3	355	64.3	355			3	4.5	23.1	64.3	355	64.3	355			3	4.5	23.1
	53.1	290	53.1	290			3	4	19	53.1	290	53.1	290			3	4	19
	42.5	255	42.5	255			3	2.9	15.3	42.5	255	42.5	255			3	2.9	15.3
	57.7	284	57.7	284	57.7	284	2	7.6	44	106.2	523	106.2	523			4	7.6	44
	57.7	330	57.7	330	57.7	330	2	7.4	37	106.2	578	106.2	578			4	7.4	37
	30.9	192	30.9	192	30.9	192	2	4.5	23.1	64.3	355	64.3	355			4	4.5	23.1
	26.9	180	26.9	180	26.9	180	2	4	19	53.1	290	53.1	290			4	4	19
	21.5	132	21.5	132	21.5	132	2	2.9	15.3	42.5	255	42.5	255			4	2.9	15.3
	106.2	523	106.2	523			3	7.6	44	106.2	523	106.2	523			3	7.6	44
	106.2	578	106.2	578			3	7.4	37	106.2	578	106.2	578			3	7.4	37
	64.3	355	64.3	355			3	4.5	23.1	64.3	355	64.3	355			3	4.5	23.1
	53.1	290	53.1	290			3	4	19	53.1	290	53.1	290			3	4	19
	42.5	255	42.5	255			3	2.9	15.3	42.5	255	42.5	255			3	2.9	15.3

**TABLE 10 - ELECTRICAL DATA WITHOUT PUMPS (CONT'D)**

CHILLER MODEL	VOLTAGE CODE	MIN CKT. AMPS	MIN N/F DISC SW	MIN DUAL ELEM FUSE & MIN CB	MAX DUAL ELEM FUSE MAX CB
125	208	512	800	600	600
	230	511	800	600	600
	380	309	400	350	350
	460	258	400	300	300
	575	204	250	225	225
136	208	579	800	600	600
	230	577	800	600	600
	380	338	600	400	400
	460	285	400	300	300
	575	226	400	250	250
142	208	579	800	600	600
	230	577	800	600	600
	380	338	600	400	400
	460	285	400	300	300
	575	226	400	250	250
155	208	618	800	700	700
	230	617	800	700	700
	380	374	600	400	400
	460	311	400	350	350
	575	246	400	300	300
156	208	634	800	700	700
	230	632	800	700	700
	380	383	600	400	400
	460	319	400	350	350
	575	252	400	300	300
170	208	740	1000	800	800
	230	738	1000	800	800
	380	447	600	500	500
	460	372	600	400	400
	575	295	400	350	350
175	208	740	1000	800	800
	230	738	1000	800	800
	380	447	600	500	500
	460	372	600	400	400
	575	295	400	350	350
200	208	734	1000	800	800
	230	731	1000	800	800
	380	443	600	500	500
	460	369	600	400	400
	575	292	400	300	300
230	208	959	1200	1000	1000
	230	956	1200	1000	1000
	380	599	600	600	600
	460	504	600	600	600
	575	359	600	400	400

**TABLE 10 - ELECTRICAL DATA WITHOUT PUMPS (CONT'D)**

		SYSTEM # 1									SYSTEM # 2								
		COMPR 1		COMPR 2		COMPR 3		STD FLOW FANS			COMPR 1		COMPR 2		COMPR 3		STD FLOW FANS		
		RLA	LRA	RLA	LRA	RLA	LRA	QTY	FLA	LRA	RLA	LRA	RLA	LRA	RLA	LRA	QTY	FLA	LRA
		106.2	523	106.2	523			4	7.6	44	106.2	523	106.2	523			4	7.6	44
		106.2	578	106.2	578			4	7.4	37	106.2	578	106.2	578			4	7.4	37
		64.3	355	64.3	355			4	4.5	23.1	64.3	355	64.3	355			4	4.5	23.1
		53.1	290	53.1	290			4	4	19	53.1	290	53.1	290			4	4	19
		42.5	255	42.5	255			4	2.9	15.3	42.5	255	42.5	255			4	2.9	15.3
		57.7	284	57.7	284	57.7	284	4	7.6	44	57.7	284	57.7	284	57.7	284	4	7.6	44
		57.7	330	57.7	330	57.7	330	4	7.4	37	57.7	330	57.7	330	57.7	330	4	7.4	37
		30.9	192	30.9	192	30.9	192	4	4.5	23.1	30.9	192	30.9	192	30.9	192	4	4.5	23.1
		26.9	180	26.9	180	26.9	180	4	4	19	26.9	180	26.9	180	26.9	180	4	4	19
		21.5	132	21.5	132	21.5	132	4	2.9	15.3	21.5	132	21.5	132	21.5	132	4	2.9	15.3
		57.7	284	57.7	284	57.7	284	3	7.6	44	57.7	284	57.7	284	57.7	284	3	7.6	44
		57.7	330	57.7	330	57.7	330	3	7.4	37	57.7	330	57.7	330	57.7	330	3	7.4	37
		30.9	192	30.9	192	30.9	192	3	4.5	23.1	30.9	192	30.9	192	30.9	192	3	4.5	23.1
		26.9	180	26.9	180	26.9	180	3	4	19	26.9	180	26.9	180	26.9	180	3	4	19
		21.5	132	21.5	132	21.5	132	3	2.9	15.3	21.5	132	21.5	132	21.5	132	3	2.9	15.3
		106.2	523	106.2	523			4	7.6	44	106.2	523	106.2	523			4	7.6	44
		106.2	578	106.2	578			4	7.4	37	106.2	578	106.2	578			4	7.4	37
		64.3	355	64.3	355			4	4.5	23.1	64.3	355	64.3	355			4	4.5	23.1
		53.1	290	53.1	290			4	4	19	53.1	290	53.1	290			4	4	19
		42.5	255	42.5	255			4	2.9	15.3	42.5	255	42.5	255			4	2.9	15.3
		106.2	523	106.2	523			4	7.6	44	106.2	523	106.2	523			4	7.6	44
		106.2	578	106.2	578			4	7.4	37	106.2	578	106.2	578			4	7.4	37
		64.3	355	64.3	355			4	4.5	23.1	64.3	355	64.3	355			4	4.5	23.1
		53.1	290	53.1	290			4	4	19	53.1	290	53.1	290			4	4	19
		42.5	255	42.5	255			4	2.9	15.3	42.5	255	42.5	255			4	2.9	15.3
		106.2	523	106.2	523	106.2	523	5	7.6	44	106.2	523	106.2	523	106.2	523	5	7.6	44
		106.2	578	106.2	578	106.2	578	5	7.4	37	106.2	578	106.2	578	106.2	578	5	7.4	37
		64.3	355	64.3	355	64.3	355	5	4.5	23.1	64.3	355	64.3	355	64.3	355	5	4.5	23.1
		53.1	290	53.1	290	53.1	290	5	4	19	53.1	290	53.1	290	53.1	290	5	4	19
		42.5	255	42.5	255	42.5	255	5	2.9	15.3	42.5	255	42.5	255	42.5	255	5	2.9	15.3
		106.2	523	106.2	523	106.2	523	5	7.6	44	106.2	523	106.2	523	106.2	523	5	7.6	44
		106.2	578	106.2	578	106.2	578	5	7.4	37	106.2	578	106.2	578	106.2	578	5	7.4	37
		64.3	355	64.3	355	64.3	355	5	4.5	23.1	64.3	355	64.3	355	64.3	355	5	4.5	23.1
		53.1	290	53.1	290	53.1	290	5	4	19	53.1	290	53.1	290	53.1	290	5	4	19
		42.5	255	42.5	255	42.5	255	5	2.9	15.3	42.5	255	42.5	255	42.5	255	5	2.9	15.3
		102.8	574	102.8	574	102.8	574	6	7.6	44	102.8	574	102.8	574	102.8	574	6	7.6	44
		102.8	635	102.8	635	102.8	635	6	7.4	37	102.8	635	102.8	635	102.8	635	6	7.4	37
		62.2	355	62.2	355	62.2	355	6	4.5	23.1	62.2	355	62.2	355	62.2	355	6	4.5	23.1
		51.4	280	51.4	280	51.4	280	6	4	19	51.4	280	51.4	280	51.4	280	6	4	19
		41.1	225	41.1	225	41.1	225	6	2.9	15.3	41.1	225	41.1	225	41.1	225	6	2.9	15.3
		138.8	943	138.8	943	138.8	943	6	7.6	44	138.8	943	138.8	943	138.8	943	6	7.6	44
		138.8	943	138.8	943	138.8	943	6	7.4	37	138.8	943	138.8	943	138.8	943	6	7.4	37
		87.2	564	87.2	564	87.2	564	6	4.5	23.1	87.2	564	87.2	564	87.2	564	6	4.5	23.1
		73	408	73	408	73	408	6	4	19	73	408	73	408	73	408	6	4	19
		51.9	375	51.9	375	51.9	375	6	2.9	15.3	51.9	375	51.9	375	51.9	375	6	2.9	15.3

**NOTE:**

- Reference PIN 59 for Pump Model.
- Use this table along with Table 8 Pump Electrical Data to determine electrical data of the unit plus the pump.
- Does not include Control Transformer.

TABLE 11 - WIRING LUGS

CHILLER MODEL	VOLTS	1 PT SUPPLY T. BLOCK	MOLDED CASE SWITCH 1 PT. SUPPLY		MOLDED CASE CIRCUIT BREAKER 1 PT. SUPPLY	
		INSTALLED LUG	INSTALLED LUG	ALTERNATE LUG	INSTALLED LUG	ALTERNATE LUG
YLAA0058	208	(1) # 6 - 500	(2) 250 - 500	(3) 2/0 - 400	(2) 3/0 - 250	(1) 250 - 500
	230	(1) # 6 - 500	(2) 250 - 500	(3) 2/0 - 400	(2) 3/0 - 250	(1) 250 - 500
	380	(1) # 6 - 500	(1) 6 - 350	-	(1) 6 - 350	-
	460	(1) # 6 - 500	(1) 6 - 350	-	(1) 6 - 350	-
	575	(1) # 6 - 500	(1) 6 - 350	-	(1) 6 - 350	-
YLAA0065	208	(2) # 6 - 500	(2) 250 - 500	(3) 2/0 - 400	(2) 3/0 - 250	(1) 250 - 500
	230	(2) # 6 - 500	(2) 250 - 500	(3) 2/0 - 400	(2) 3/0 - 250	(1) 250 - 500
	380	(1) # 6 - 500	(1) 250 - 500	(2) 3/0 - 250	(1) 6 - 350	-
	460	(1) # 6 - 500	(1) 6 - 350	-	(1) 6 - 350	-
	575	(1) # 6 - 500	(1) 6 - 350	-	(1) 6 - 350	-
YLAA0070	208	(2) # 6 - 500	(2) 250 - 500	(3) 2/0 - 400	(2) 3/0 - 250	(1) 250 - 500
	230	(2) # 6 - 500	(2) 250 - 500	(3) 2/0 - 400	(2) 3/0 - 250	(1) 250 - 500
	380	(1) # 6 - 500	(1) 6 - 350	-	(1) 6 - 350	-
	460	(1) # 6 - 500	(1) 6 - 350	-	(1) 6 - 350	-
	575	(1) # 6 - 500	(1) 6 - 350	-	(1) 6 - 350	-
YLAA0080	208	(2) # 6 - 500	(2) 250 - 500	(3) 2/0 - 400	(2) 3/0 - 250	(1) 250 - 500
	230	(2) # 6 - 500	(2) 250 - 500	(3) 2/0 - 400	(2) 3/0 - 250	(1) 250 - 500
	380	(1) # 6 - 500	(2) 3/0 - 250	(1) 250 - 500	(1) 6 - 350	-
	460	(1) # 6 - 500	(1) 6 - 350	-	(1) 6 - 350	-
	575	(1) # 6 - 500	(1) 6 - 350	-	(1) 6 - 350	-
YLAA0081	208	(2) # 6 - 500	(2) 250 - 500	(3) 2/0 - 400	(3) 2/0 - 400	(2) 250 - 500
	230	(2) # 6 - 500	(2) 250 - 500	(3) 2/0 - 400	(3) 2/0 - 400	(2) 250 - 500
	380	(1) # 6 - 500	(1) 250 - 500	(2) 3/0 - 250	(2) 3/0 - 250	(1) 250 - 500
	460	(1) # 6 - 500	(1) 250 - 500	(2) 3/0 - 250	(1) 6 - 350	-
	575	(1) # 6 - 500	(1) 6 - 350	-	(1) 6 - 350	-
YLAA0089	208	(2) # 6 - 500	(2) 250 - 500	(3) 2/0 - 400	(2) 250 - 500	(3) 2/0 - 400
	230	(2) # 6 - 500	(2) 250 - 500	(3) 2/0 - 400	(2) 250 - 500	(3) 2/0 - 400
	380	(1) # 6 - 500	(2) 3/0 - 250	(1) 250 - 500	(2) 3/0 - 250	(1) 250 - 500
	460	(1) # 6 - 500	(1) 250 - 500	(2) 3/0 - 250	(1) 6 - 350	-
	575	(1) # 6 - 500	(1) 6 - 350	-	(1) 6 - 350	-
YLAA0092	208	(2) # 6 - 500	(2) 250 - 500	(3) 2/0 - 400	(2) 250 - 500	(3) 2/0 - 400
	230	(2) # 6 - 500	(2) 250 - 500	(3) 2/0 - 400	(2) 250 - 500	(3) 2/0 - 400
	380	(1) # 6 - 500	(2) 3/0 - 250	(1) 250 - 500	(2) 3/0 - 250	(1) 250 - 500
	460	(1) # 6 - 500	(1) 250 - 500	(2) 3/0 - 250	(1) 6 - 350	-
	575	(1) # 6 - 500	(1) 6 - 350	-	(1) 6 - 350	-
YLAA0100 YLAA0101	208	(2) # 6 - 500	(2) 250 - 500	(3) 2/0 - 400	(2) 250 - 500	(3) 2/0 - 400
	230	(2) # 6 - 500	(2) 250 - 500	(3) 2/0 - 400	(2) 250 - 500	(3) 2/0 - 400
	380	(1) # 6 - 500	(2) 3/0 - 250	(1) 250 - 500	(2) 3/0 - 250	(1) 250 - 500
	460	(1) # 6 - 500	(2) 3/0 - 250	(1) 250 - 500	(2) 3/0 - 250	(1) 250 - 500
	575	(1) # 6 - 500	(1) 6 - 350	-	(1) 6 - 350	-

**TABLE 11 - WIRING LUGS (CONT'D)**

CHILLER MODEL	VOLTS	1 PT SUPPLY T. BLOCK	MOLDED CASE SWITCH 1 PT. SUPPLY		MOLDED CASE CIRCUIT BREAKER 1 PT. SUPPLY	
		INSTALLED LUG	INSTALLED LUG	ALTERNATE LUG	INSTALLED LUG	ALTERNATE LUG
YLAA0120 YLAA0130 YLAA0125	208	(2) # 6 - 500	(3) 2/0 - 400	(2) 250 - 500	(3) 2/0 - 400	(2) 250 - 500
	230	(2) # 6 - 500	(3) 2/0 - 400	(2) 250 - 500	(3) 2/0 - 400	(2) 250 - 500
	380	(1) # 6 - 500	(2) 3/0 - 250	(1) 250 - 500	(2) 3/0 - 250	(1) 250 - 500
	400/460	(1) # 6 - 500	(2) 3/0 - 250	(1) 250 - 500	(2) 3/0 - 250	(1) 250 - 500
	575	(1) # 6 - 500	(2) 3/0 - 250	(1) 250 - 500	(2) 3/0 - 250	(1) 250 - 500
YLAA0135 YLAA0141	208	(2) # 6 - 500	(3) 2/0 - 400	(2) 250 - 500	(3) 2/0 - 400	(2) 250 - 500
	230	(2) # 6 - 500	(3) 2/0 - 400	(2) 250 - 500	(3) 2/0 - 400	(2) 250 - 500
	380	(1) # 6 - 500	(2) 250 - 500	(3) 2/0 - 400	(2) 3/0 - 250	(1) 250 - 500
	400/460	(1) # 6 - 500	(1) 250 - 500	(2) 3/0 - 250	(1) 250 - 500	(2) 3/0 - 250
	575	(1) # 6 - 500	(1) 250 - 500	(2) 3/0 - 250	(1) 250 - 500	(2) 3/0 - 250
YLAA0136 YLAA0142	208	(2) # 6 - 500	(2) 250 - 500	(3) 2/0 - 400	(2) 250 - 500	(3) 2/0 - 400
	230					
	380	(2) # 6 - 500	(3) 2/0 - 400	(2) 250 - 500	(2) 3/0 - 250	(1) 250 - 500
	400/460	(1) # 6 - 500	(1) 250 - 500	(2) 3/0 - 250	(1) 250 - 500	(2) 3/0 - 250
	575	(1) # 6 - 500	(1) 250 - 500	(2) 3/0 - 250	(1) 250 - 500	(2) 3/0 - 250
YLAA0150 YLAA0155 YLAA0158 YLAA0156	208	(3) 2/0 - 400	(3) 2/0 - 400	(2) 250 - 500	(3) 2/0 - 400	(2) 250 - 500
	230	(3) 2/0 - 400	(3) 2/0 - 400	(2) 250 - 500	(3) 2/0 - 400	(2) 250 - 500
	380	(2) # 6 - 500	(2) 250 - 500	(3) 2/0 - 400	(2) 250 - 500	(3) 2/0 - 400
	400/460	(2) # 6 - 500	(1) 250 - 500	(2) 3/0 - 250	(1) 250 - 500	(2) 3/0 - 250
	575	(1) # 6 - 500	(2) 3/0 - 250	(1) 250 - 500	(2) 3/0 - 250	(1) 250 - 500
YLAA0170 YLAA0175 YLAA0200	208	(4) 4/0 - 500	(4) 4/0 - 500	-	(3) 2/0 - 400	(2) 250 - 500
	230	(4) 4/0 - 500	(4) 4/0 - 500	-	(3) 2/0 - 400	(2) 250 - 500
	380	(2) # 6 - 500	(2) 250 - 500	(3) 2/0 - 400	(2) 250 - 500	(3) 2/0 - 400
	460	(2) # 6 - 500	(2) 250 - 500	(3) 2/0 - 400	(2) 3/0 - 250	(1) 250 - 500
	575	(1) # 6 - 500	(2) 3/0 - 250	(1) 250 - 500	(2) 3/0 - 250	(1) 250 - 500
YLAA0230	208	(4) 4/0 - 500	(4) 4/0 - 500	-	(4) 4/0 - 500	-
	230	(4) 4/0 - 500	(4) 4/0 - 500	-	(4) 4/0 - 500	-
	460	(2) # 6 - 500	(2) 250 - 500	(3) 2/0 - 400	(2) 250 - 500	(3) 2/0 - 400
	575	(2) # 6 - 500	-	-	(2) 3/0 - 250	(1) 250 - 500

5

## ELECTRICAL NOTES

### NOTES

1. Minimum Circuit Ampacity (MCA) is based on 125% of the rated load amps for the largest motor plus 100% of the rated load amps for all other loads included in the circuit, per N.E.C. Article 430-24. If the optional Factory Mounted Control Transformer is provided, add the following MCA values to the electrical tables for the system providing power to the transformer: -17, add 2.5 amps; -28, add 2.3 amps; -40, add 1.5 amps, -46, add 1.3 amps; -58, add 1 amps.
2. The minimum recommended disconnect switch is based on 115% of the rated load amps for all loads included in the circuit, per N.E.C. Article 440.
3. Minimum fuse size is based upon 150% of the rated load amps for the largest motor plus 100% of the rated load amps for all other loads included in the circuit to avoid nuisance trips at start-up due to lock rotor amps. It is not recommended in applications where brown outs, frequent starting and stopping of the unit, and/or operation at ambient temperatures in excess of 95°F (35°C) is anticipated.
4. Maximum fuse size is based upon 225% of the rated load amps for the largest motor plus 100% of the rated load amps for all other loads included in the circuit, per N.E.C. Article 440-22.
5. Circuit breakers must be UL listed and CSA certified and maximum size is based on 225% of the rated load amps for the largest motor plus 100% of the rated load amps for all other loads included in the circuit. Otherwise, HACR-type circuit breakers must be used. Maximum HACR circuit breaker rating is based on 225% of the rated load amps for the largest motor plus 100% of the rated load amps for all other loads included in the circuit.
6. The “INCOMING WIRE RANGE” is the minimum and maximum wire size that can be accommodated by the unit wiring lugs. The (2) preceding the wire range indicates the number of termination points available per phase of the wire range specified. Actual wire size and number of wires per phase must be determined based on the National Electrical Code, **using copper connectors only**. Field wiring must also comply with local codes.
7. A ground lug is provided for each compressor system to accommodate a field grounding conductor per N.E.C. Table 250-95. A control circuit grounding lug is also supplied.
8. The supplied disconnect is a “Disconnecting Means” as defined in the N.E.C. 100, and is intended for isolating the unit for the available power supply to perform maintenance and troubleshooting. This disconnect is not intended to be a Load Break Device.
9. Field Wiring by others which complies to the National Electrical Code and Local Codes.

### LEGEND

ACR-LINE	ACROSS THE LINE START
C.B.	CIRCUIT BREAKER
D.E.	DUAL ELEMENT FUSE
DISC SW	DISCONNECT SWITCH
FACT MOUNT CB	FACTORY MOUNTED CIRCUIT BREAKER
FLA	FULL LOAD AMPS
HZ	HERTZ
MAX	MAXIMUM
MCA	MINIMUM CIRCUIT AMPACITY
MIN	MINIMUM
MIN NF	MINIMUM NON FUSED
RLA	RATED LOAD AMPS
S.P. WIRE	SINGLE POINT WIRING
UNIT MTD SERV SW	UNIT MOUNTED SERVICE (NON-FUSED DISCONNECT
LRA	LOCKED ROTOR AMPS

### VOLTAGE CODE

-17 = 200-208-3-60
-28 = 230-3-60
-40 = 380-3-60
-46 = 460-3-60
-50 = 380/415-3-50
-58 = 575-3-60

## ELECTRICAL NOTES AND LEGEND

DESIGNATION	DESCRIPTION
ACC	ACCESSORY
- ADIS	DISPLAY BOARD
- AMB	MICRO BOARD
- AUX	AUXILIARY SWITCH
- BAMB	AMBIENT
- BDAT	DISCHARGE AIR TEMPERATURE
- BDP	DISCHARGE PRESSURE
- BECT	ENTERING CHILLED TEMPERATURE
- BLCT	LEAVING CHILLED TEMPERATURE NOT FITTED ON REMOTE EVAP UNITS
- BMP	MOTOR PROTECTOR COMPRESSOR
- BSP	SUCTION PRESSURE
BST	SUCTION TEMPERATURE
- CPF	CAPACITOR POWER FACTOR
- ECH	CRANKCASE HEATER
- EEH	EVAPORATOR HEATER
- EEV	ELECTRONIC EXPANSION VALVE
- EEVC	ELEC. EXPAN. VALVE CONTROLLER
- EHRH	HEAT RECOVERY HEATER
- EPH	PUMP HEATER
-ETXVH	EXPANSION VALVE HEATER
- ETH	TRACE HEATER
- EXT	EXTERNAL TO CONTROL PANEL
- F	FUSE
- FHP	HIGH PRESSURE CUTOUT
- FSC	FAN SPEED CONTROLLER
- FSI	FAN SPEED INHIBIT TWO SPEED FAN OPTION ONLY
GND	GROUND
G/Y	GREEN / YELLOW
J	PLUG BOARD CONNECTOR
- K	CIRCUIT BOARD RELAY
- KEEV	ELECTRONIC EXPANSION VALVE CONTROL RELAY
- KF	FAN CONTACTOR LINE (INCLUDING COIL SUPPRESSOR)
- KFH	FAN CONTACTOR HIGH SPEED (INCLUDING COIL SUPPRESSOR)
- KFL	FAN CONTACTOR LOW SPEED (INCLUDING COIL SUPPRESSOR)
- KFOL	FAN OVERLOAD
- KFS	RELAY FAN SPEED
- KH	HEATER RELAY
- KM	COMPRESSOR CONTACTOR (INCLUDING COIL SUPPRESSOR)
- KCR	CONTROL RELAY
- KP	PUMP CONTACTOR PART (INCLUDING COIL SUPPRESSOR)

DESIGNATION	DESCRIPTION
- KT	RELAY TIMER
- M	COMPRESSOR MOTOR
- MF	MOTOR FAN
- MP	MOTOR PUMP
NU	NOT USED
PE	PROTECTIVE EARTH
PWM	PULSE WIDTH MODULATION TEMP RESET or REMOTE UNLOAD 2nd STEP
- QCB	CIRCUIT BREAKER
- QMMSC	MANUAL MOTOR STARTER COMPRESSOR
- QMMSPP	MANUAL MOTOR STARTER PUMP
- QSD	SWITCH DISCONNECT
R	RESISTOR
RED	RED
RP	RUN PERMISSIVE
RU	REMOTE UNLOAD 1st STEP
SCH	THERMOSTAT CRANKCASE HEATER
SCR	SCREEN
- SF	FLOW SWITCH
- SFE	FLOW SWITCH ELECTRONIC
- SKP	KEYPAD
- SOA	SWITCH OFF AUTO
- SZT	ZONE THERMOSTAT
- T	TRANSFORMER
- TC	TRANSFORMER CURRENT
TXV	THERMAL EXPANSION VALVE
- UBR	BRIDGE RECTIFIER
- WHT	WHITE
- XP	PLUGS BETWEEN POW./MICRO. SECTION
- XTBC	TERMINAL BLOCK CUSTOMER
- XTBF	TERMINAL BLOCK FACTORY
- XTBM	TERMINAL BLOCK MOTOR FAN TRIP
- YESV	EVAPORATOR SOLENOID VALVE
- YHGSV	HOT GAS SOLENOID VALVE (INCLUDING COIL SUPPRESSOR)
- YLLSV	LIQUID LINE SOLENOID VALVE FIELD MOUNTED AND WIRED ON REMOTE EVAP. UNITS
- ZCPR	COMPRESSOR
(NB)	NOTE WELL (SEE NOTE)
- - - - -	WIRING AND ITEMS SHOWN THUS ARE STANDARD YORK ACCESSORIES
- · - - - -	WIRING AND ITEMS SHOWN THUS ARE NOT SUPPLIED BY YORK
— — —	ITEMS THUS ENCLOSED FORM A COMPO- NENTS OR SETS OF COMPONENTS

**ELECTRICAL NOTES AND LEGEND (CONT'D)**

035-21966-101 REV V

<b>GENERAL</b>	
a.	This drawing is based on IEC symbols.
b.	Field wiring to be in accordance with the relevant electrical code as well as all other applicable codes and specifications.
c.	All sources of supply shown on this diagram to be taken from one main isolator, not shown or supplied by YORK.
d.	Green and yellow wire is used for earth, multi-colored cable used for low voltage. Red wire used for AC Control, blue wire for neutral, black wire for AC and DC power. Orange wire should be used for interlock control wiring supplied by external source.
e.	Legend designation depicts component abbreviations. Number prefix located, if applicable, on schematic circuit, refers to system thereon, E.G. = 1-FHP2 refers to high pressure cutout no 2 on system no 1.
f.	All wiring to control section voltage free contacts requires a supply provided by the customer maximum voltage 240 volts. The customer must take particular care when deriving the supplies for the voltage free terminals with regard to a common point of isolation. Thus, these circuits when used must be fed via the common point of isolation the voltage to these circuits is removed when the common point of isolation to the unit is opened. This common point of isolation is not supplied by YORK. The YORK voltage free contacts are rated at 100va. All inductive devices {relays} switch by the YORK voltage free contacts must have their coil suppressed using standard R/C suppressors.
g.	Customer voltage free contacts connected to terminal 13 must be rated at 30V 5ma.
h.	No controls {relays etc.} Should be mounted in any section of the control panel. Additionally, control wiring not connected to the YORK control panel should not be run through the panel. If these precautions are not followed, electrical noise could cause malfunctions or damage to the unit and its controls.
i.	 120/14.3 - (Signal IN/OUT) i.e. 120 is wire # and 14.3 refers to SHT. 14 column 3.
<b>NOTES</b>	
1	Refer to installation commissioning operation and maintenance manual for customer connections and customer connection notes, non compliance to these instructions will invalidate unit warranty.
2	Wiring and components for compressor 3 only fitted when unit has 3 compressors on the system. 1-BMP3 is replaced by a link across terminals 134 & 135. 2-BMP3 is replaced by a link across terminals 234 & 235.
3	-
4	Fitted on units with hot gas bypass option.
5	EMS option is wired as shown.
6	This wiring must be used for old display 031-0110-000.
7	Network connection point.
8	Printer port.
9	Remote emergency stop can be wired between terminal 1 and 5 after removing link.
10	Power factor correction accessory. Power factor correction fitted to each compressor contactor.
11	Not fitted on compressors with internal motor protection. For system 1 terminals 132 & 133, 133 & 134 and 134 & 135 are linked. For system 2 terminals 232 & 233, 233 & 234 and 234 & 235 are linked.
12	Only fitted on systems with 3 or more fans.
13	Only fitted on systems with 4 fans.
14	Only fitted on systems with 5 fans.
15	Only fitted on systems with 6 fans.
16	Input switch disconnect (standard on CE units) or circuit breaker option replaces input terminal block.
17	Input switch disconnect & individual system circuit breaker option replaces input terminal block.
18	115V control circuit requires a 115V supply unless control circuit transformer -T2 & -F3 are fitted (standard on CE units).
19	Fitted on hydro kit option. On single pump -KP1, -QMMSP1 & -MP1 are fitted & wired as shown. On two pump hydro kits -KP2, -QMMSP2 & -MP2 are also fitted and wired as shown. Insulated wire 1E under -F1 is connected to -F1.
20	Current measurement option wired as show.
21	Only fitted on systems with single speed fans.
22	Only fitted on systems with two speed fans.
23	Optional compressor manual motors starters (standard on CE units).
24	See sheet 3 of connection diagram for power input options.
25	Alternate connections shown for different two speed motor types.
26	Only fitted on systems with a maximum of 4 fans.
27	220/230V units require a separate fuse for units w/4 or more fans per system.
28	Low ambient kit -FSC for fan -MF1 is only fitted on systems with less than 4 fans.
29	Only fitted on YLAA0091, 0220, 0240, 0260 and YLUA0098, 0308
30	Only fitted on YLAA0090, 0091, 0240, 0260, 0285, 0300, 0390 & YLUA0095, 0098, 0148, 0298, 0308, 0468
31	Input dual point circuit breaker option replaces input terminal block.

## ELECTRICAL NOTES AND LEGEND (CONT'D)

32	Field installed on remote evaporator units.
33	Fitted on units with single phase motors only.
34	Fitted on units with low ambient option only.
35	Only fitted on units with an acoustic kit.
36	Only fitted on heat recovery units.
37	Only fitted on condensing units.
38	Omitted on condensing units.
39	Fitted on units with low ambient option using single phase motors (50hz only).
40	Fitted on units with high airflow fan option only.
41	Part of E-link kit option.
42	Part of temp. sensor kit (on condensing units only).
43	-
44	When the compressors motor protection (-bmp) includes phase reversal the extra -bmp terminals and three wires are fitted as shown in the compressor terminal box as detailed. Terminal L1, L2, L3 with wires colored red, black, white or alternatively just wires colored (black) (brown) (blue)
45	Omitted on units with EEV
46	EEV option
47	Only fitted on units with plate evaporator
48	Only fitted on unit with shell and tube evaporator
49	Fitted on units with second hot gas bypass (2-YHGSV).
50	Units with plate evaporators - flow switch -SFE is fitted as standard on units that have 7 or more fans, ref 035-21589-107, units with hydro kit or pipe extension kit. Units with shell and tube evaporator and hydro kit flow switch -SF is fitted. For all other units - the customer must fit a field mounted flow switch, wired to terminals 13 and 14 on -XTBC1.
51	Only fitted on units with plate evaporator that have 7 or more fans
52	Not fitted on units with plate evaporator that have 7 or more fans
53	On systems with 3 fan contactors wire number in ( ) replaces wire number shown
54	Only fitted on systems with 4 or more fans
55	Only fitted on systems with 5 or more fans
56	Soft starter option details shown on sheet -120 of schematic replaces the standard drawing details for a unit with two compressor on system 1
57	Soft starter option details shown on sheet -120 of schematic replaces the standard drawing details for a unit with three compressor on system 1
58	Soft starter option details shown on sheet -120 of schematic replaces the standard drawing details for a unit with two compressor on system 2
59	Soft starter option details shown on sheet -120 of schematic replaces the standard drawing details for a unit with three compressor on system 2
60	On systems with 2 compressors wire number in ( ) replaces wire number shown
61	Not fitted on units with soft starter option
62	Soft starter option details shown on sheet -121 of schematic replaces the standard drawing with 2-compressors on system 1
63	Soft starter option details shown on sheet -121 of schematic replaces the standard drawing with 2-compressors on system 2
64	VSD single pump option with fuses, details shown on sheet -122 of schematic replaces the standard drawing -105.
65	VSD dual pump option with fuses, details shown on sheet -122 of schematic replaces the standard drawing -105.
66	VSD single pump option with circuit breakers, details shown on sheet -122 of schematic replaces the standard drawing -105.
67	VSD dual pump option with circuit breakers, details shown on sheet -122 of schematic replaces the standard drawing -105.
68	VSD fan option details shown on drawing -123
	A System 1 with 3-fans - details shown on drawing - 123
	B System 1 with 4-fans - details shown on drawing - 123
	C System 1 with 5-fans - details shown on drawing - 123
	D System 1 with 6-fans - details shown on drawing - 123
	E System 2 with 3-fans - details shown on drawing - 123
	F System 2 with 4-fans - details shown on drawing - 123
G System 3 with 5-fans - details shown on drawing - 123	
69	Auxiliary switches for manual motor protectors
70	Auxiliary switches for manual motor protectors for 3 compressor units only

# WIRING DIAGRAMS ELEMENTARY WIRING DIAGRAMS

035-21583-101 REV O

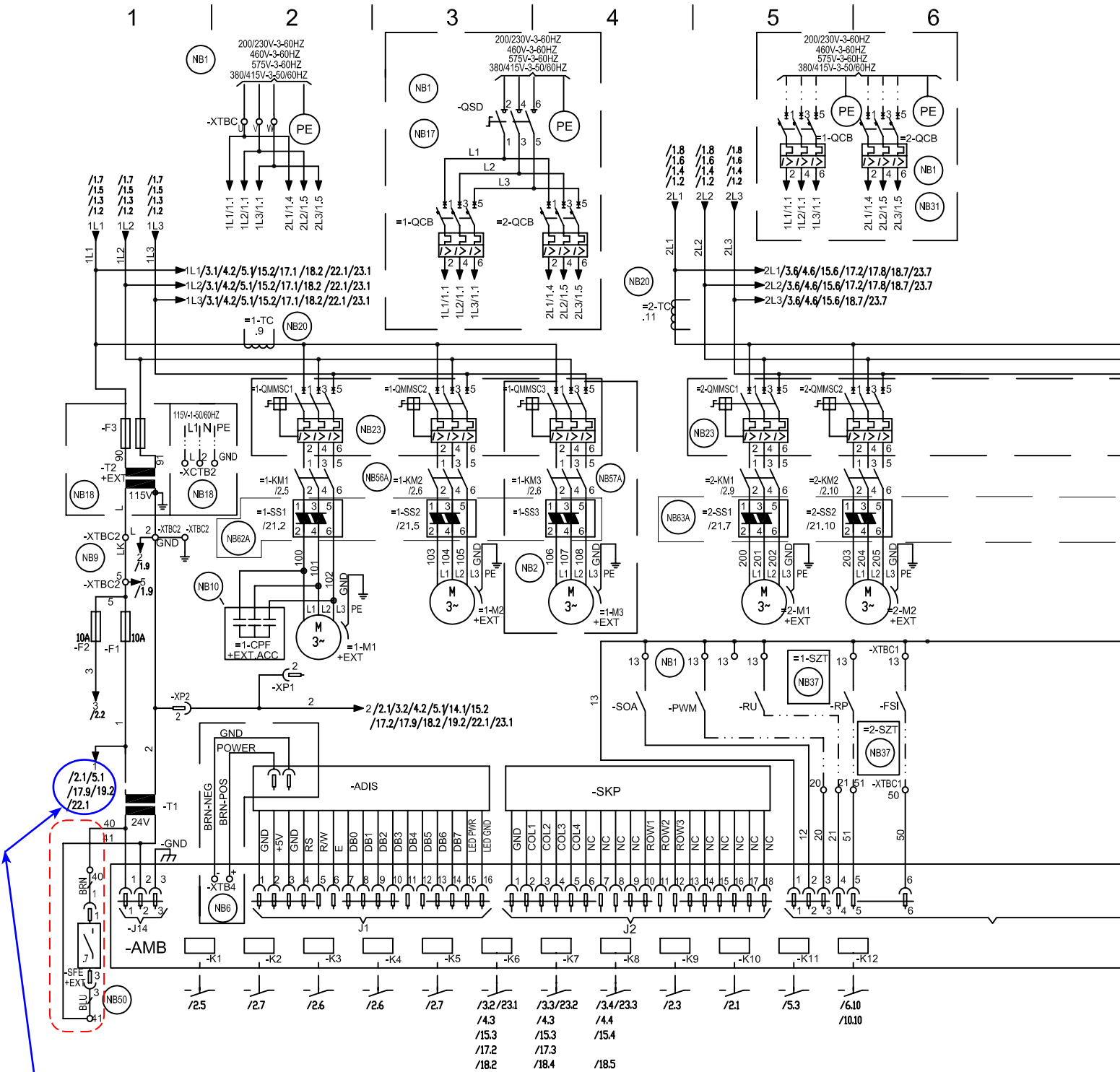

**1/2.1** What these numbers mean. Example:  
**1** = follow wire no.1  
**2.** = is the DWG number on the bottom center of each page.  
**.1** = is the locator number across the top of the page.  
 At the top of the pages the numbers 1 to 11 go from left to right. Find drawing number 2 and in column number 1 across the top of the page, locate wire number 1.

DWG. 1

**FIGURE 14 - ELEMENTARY WIRING DIAGRAM**

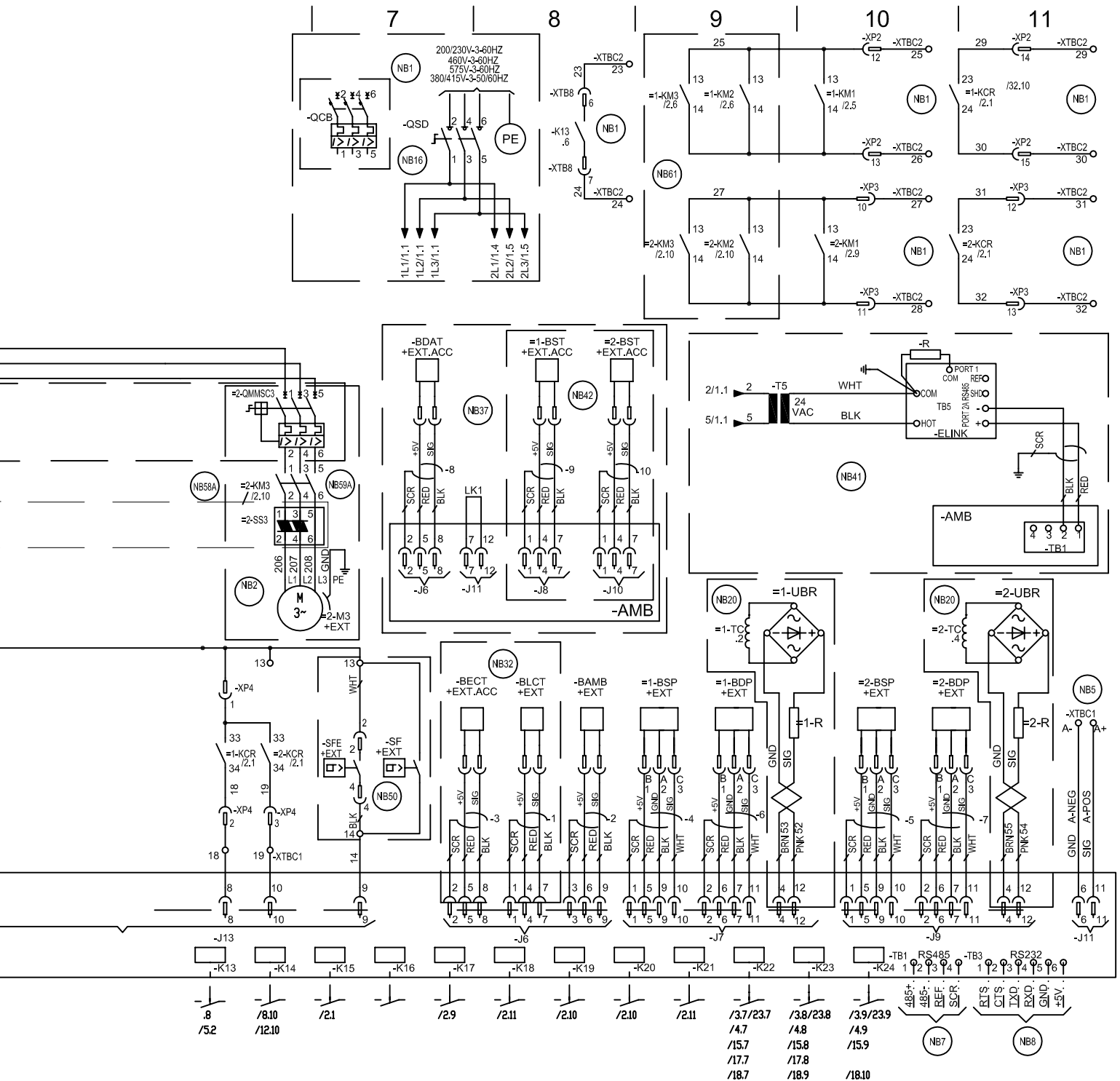

DWG. 1

FIGURE 14 - ELEMENTARY WIRING DIAGRAM (CONT'D)

035-21583-102 REV O

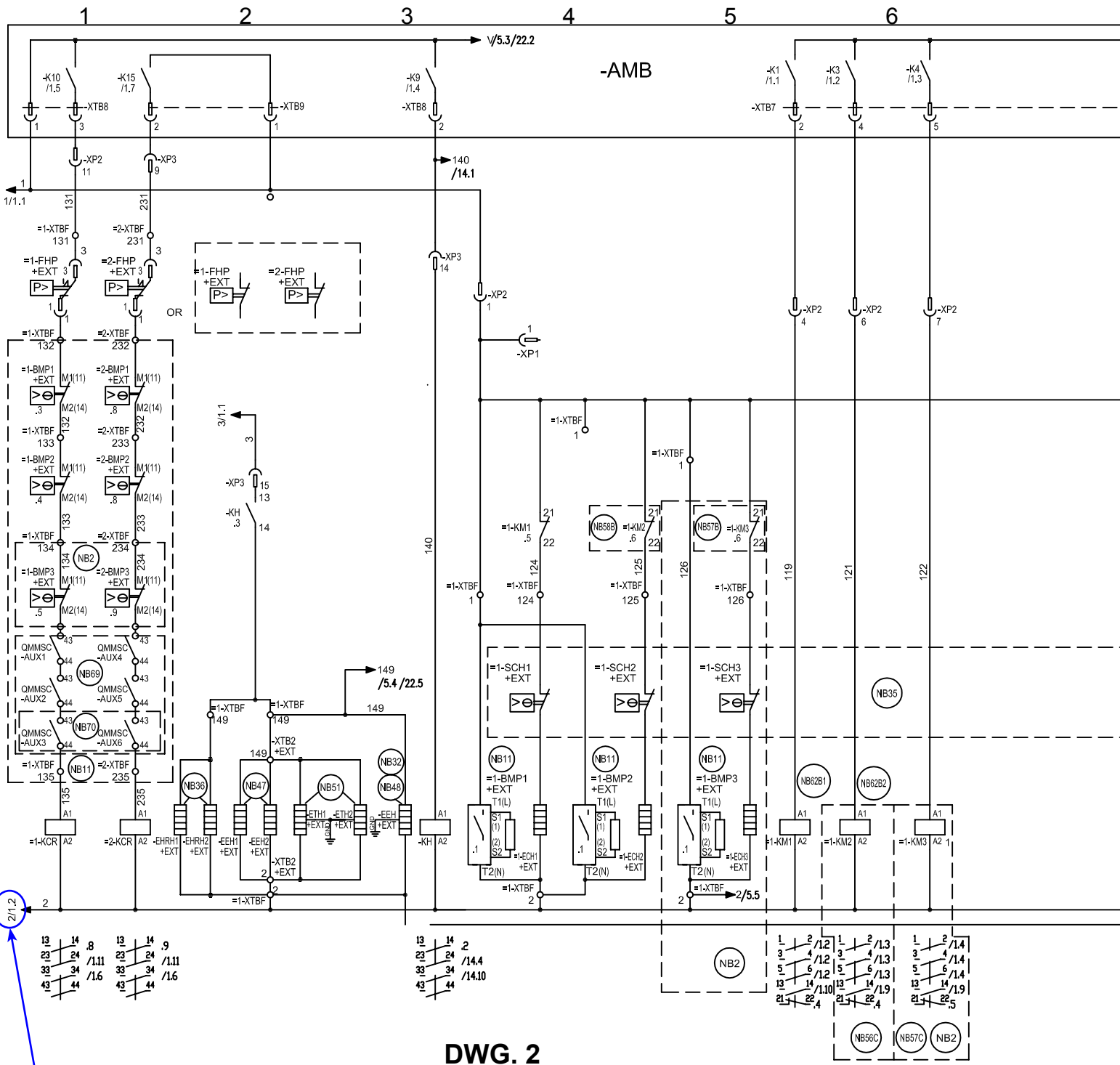

DWG. 2

**1/2.1** What these numbers mean. Example:  
**1** = follow wire no.1  
**2.** = is the DWG number on the bottom center of each page.  
**.1** = is the locator number across the top of the page.  
 At the top of the pages the numbers **1** to **11** go from left to right. Find drawing number **2** and in column number **1** across the top of the page, locate wire number **1**.

LD16750b

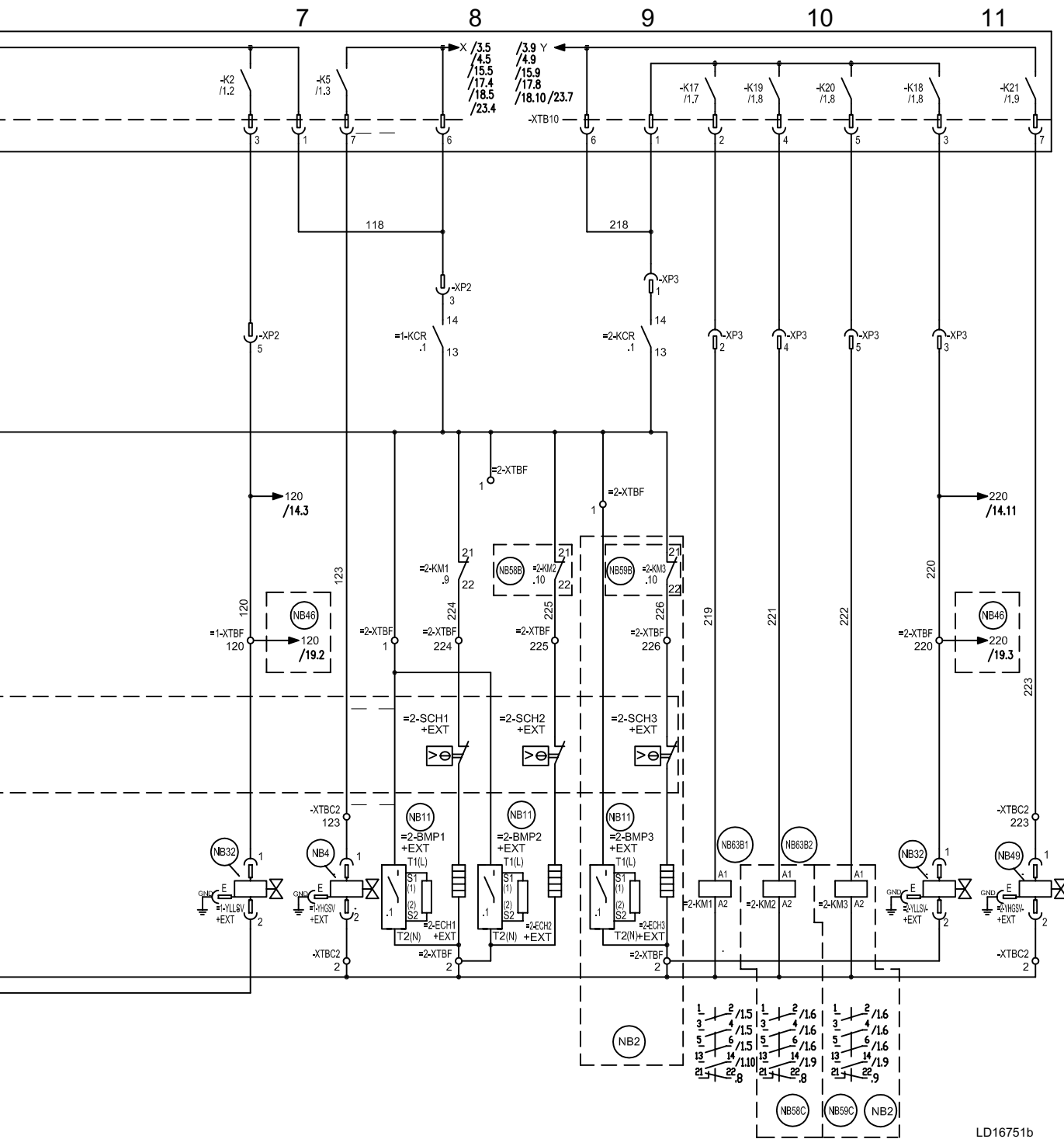

DWG. 2

LD16751b

FIGURE 15 - ELEMENTARY WIRING DIAGRAM (CONT'D)

# FAN WIRING

035-21583-125 REV - A

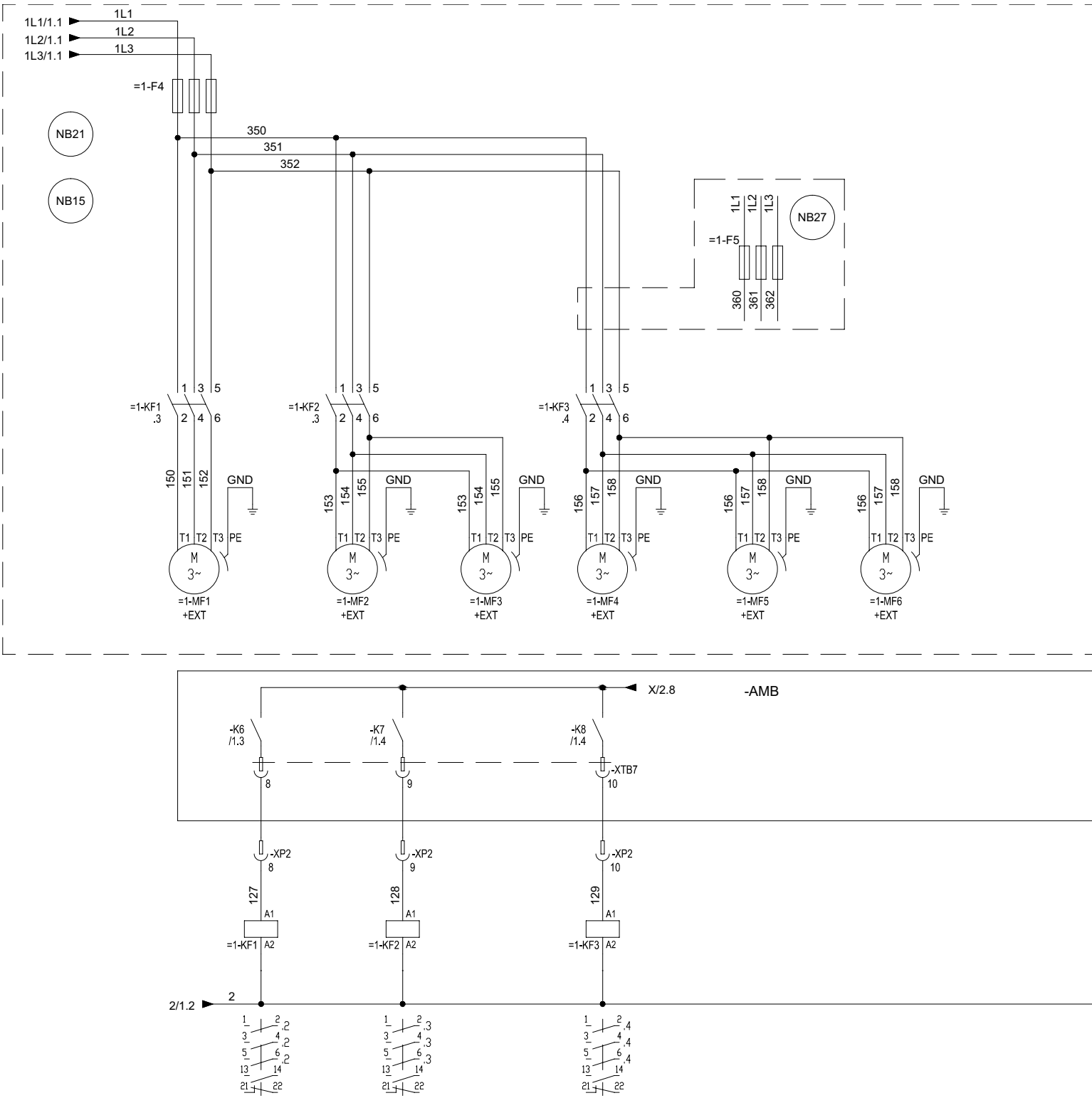

LD21181a

FIGURE 16 - FAN WIRING, STANDARD AIR FLOW

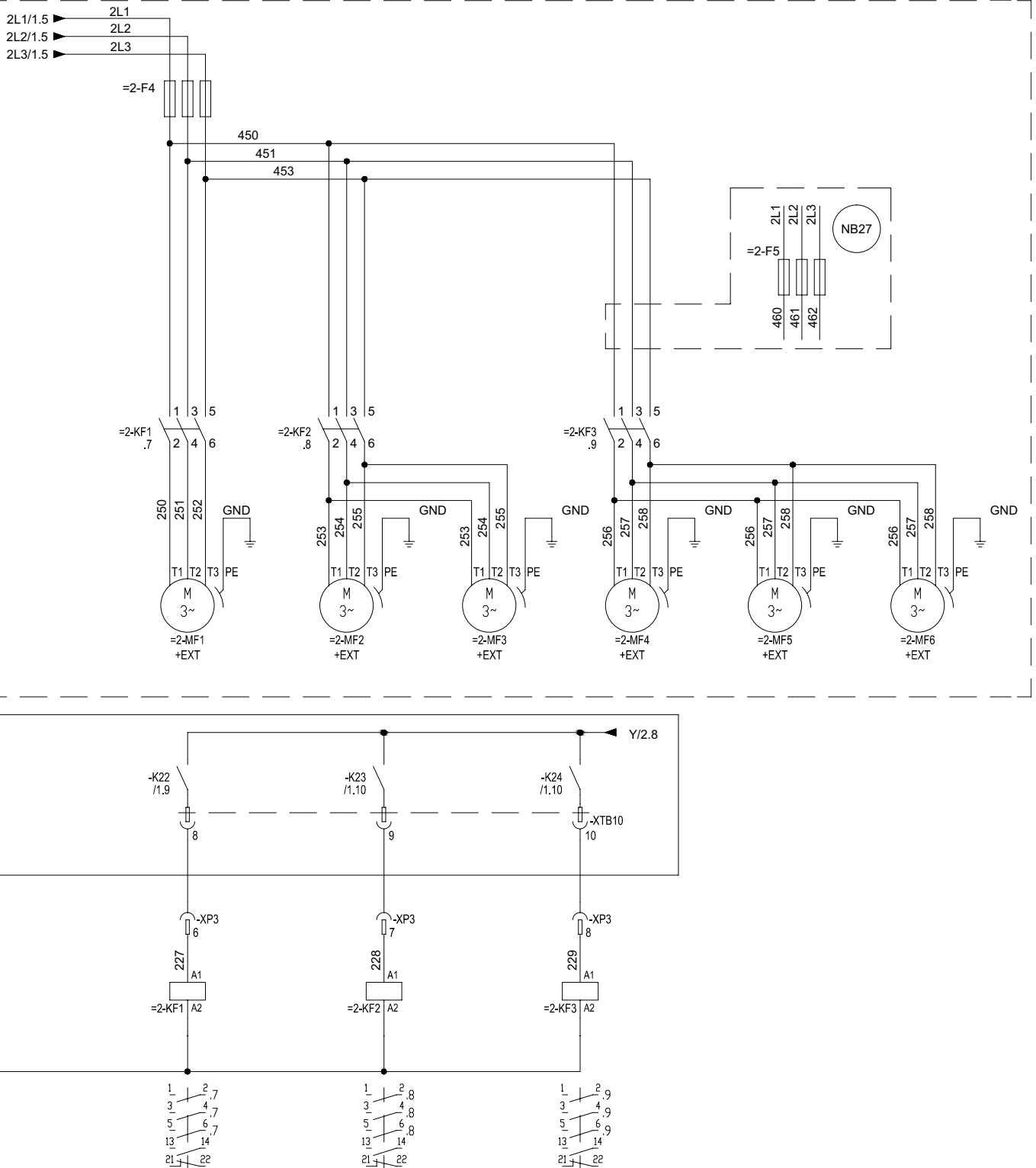

5

LD21181b

FIGURE 16 - FAN WIRING, STANDARD AIR FLOW (CONT'D)

# FAN WIRING

035-21583-118 REV F

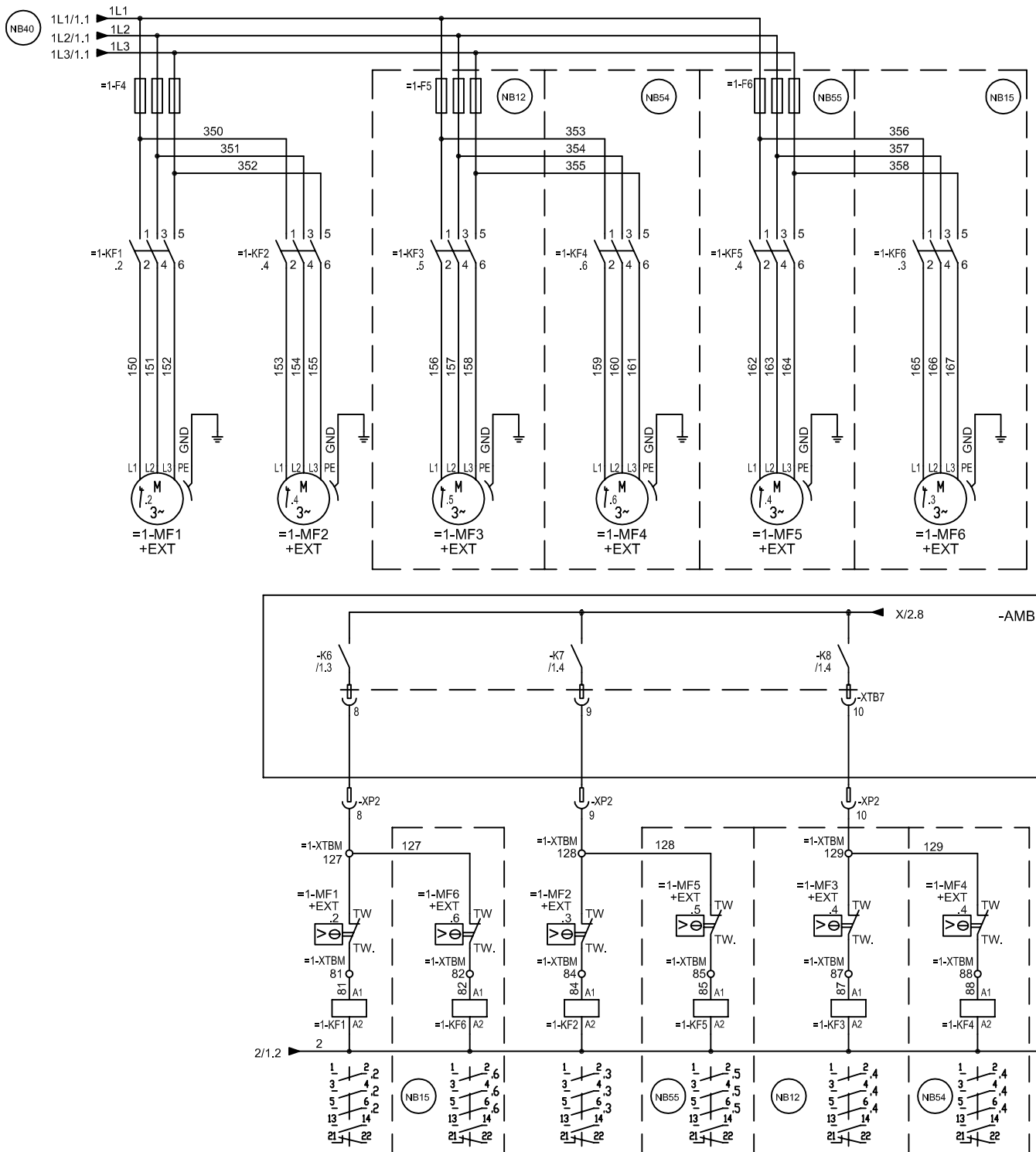

LD21180a

FIGURE 17 - FAN WIRING, HIGH AIR FLOW

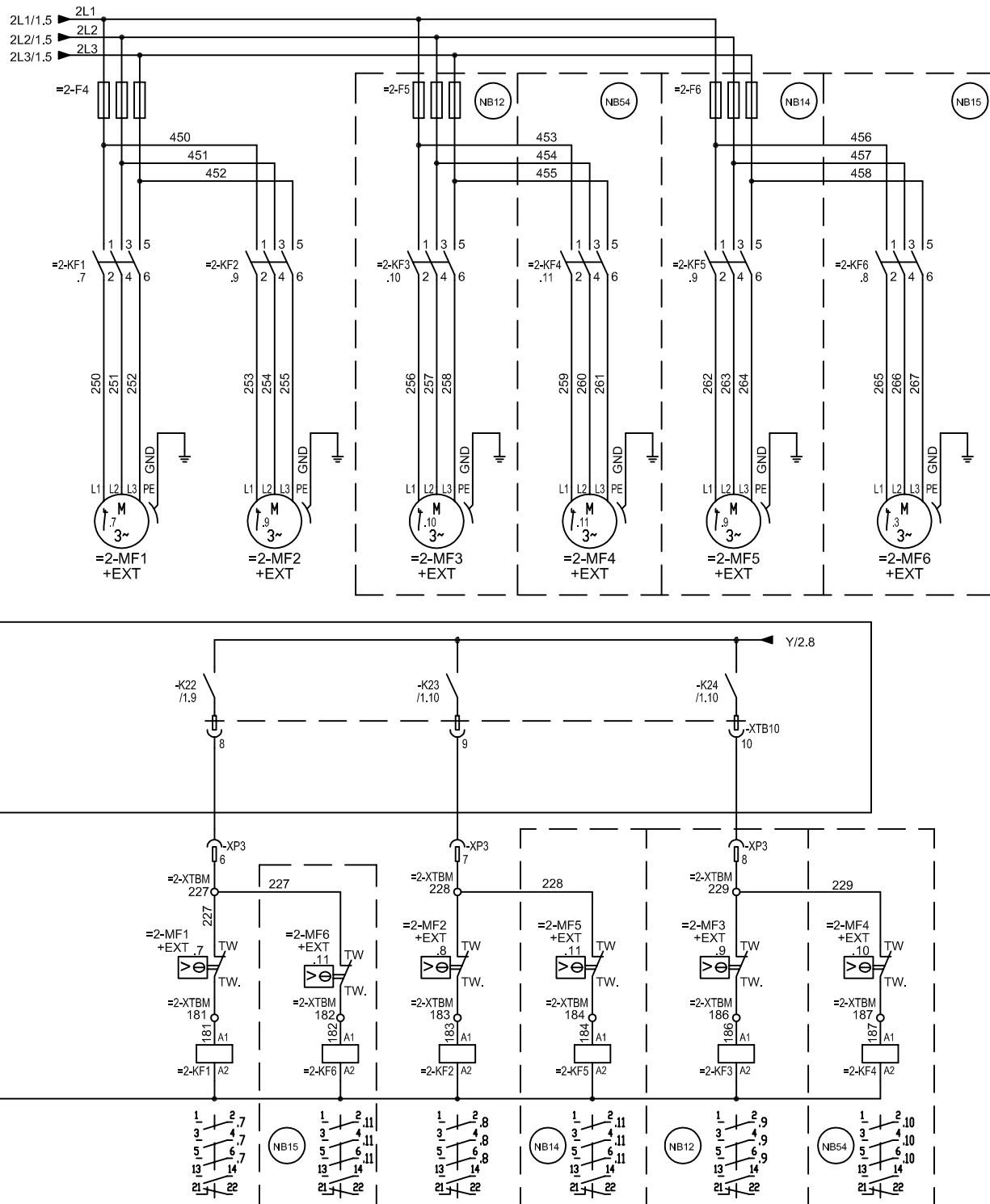

LD21180b

FIGURE 17 - FAN WIRING, HIGH AIR FLOW (CONT'D)

# SINGLE AND DUAL POINT WIRING OPTIONS

035-21583-116 REV C

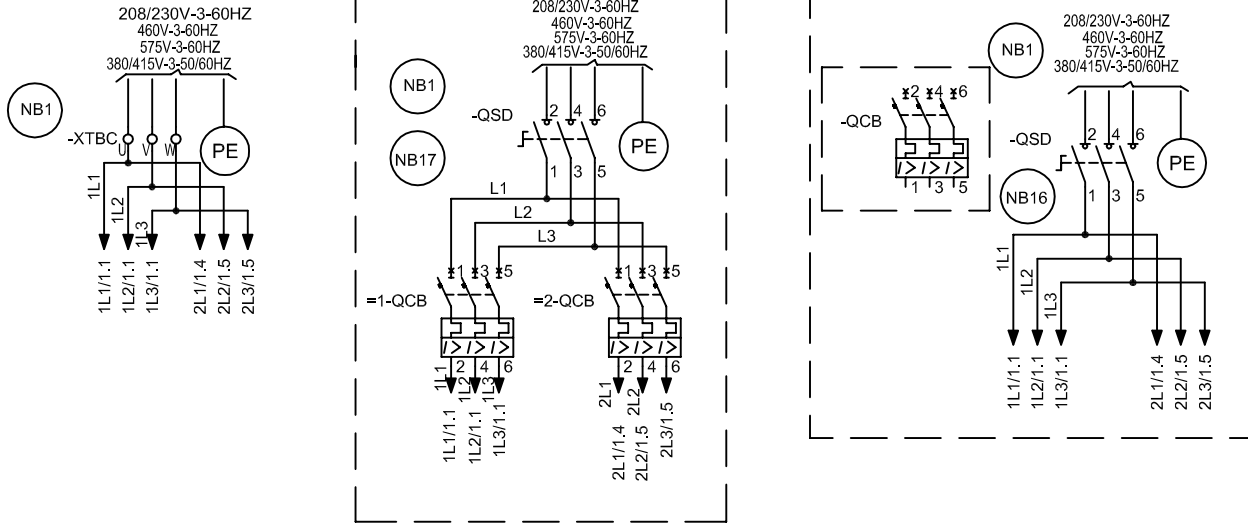

## SINGLE POINT WIRING OPTIONS

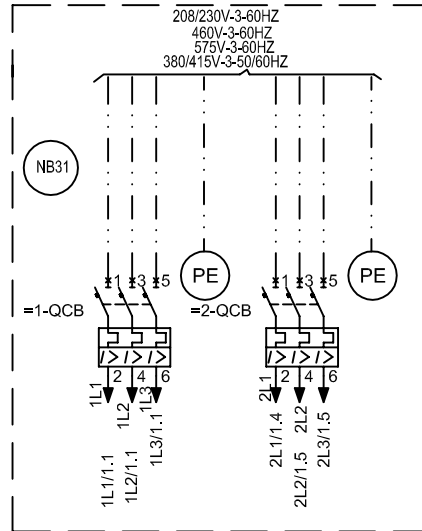

## DUAL POINT WIRING OPTIONS

**DWG. 16**

LD21208

**FIGURE 18 - SINGLE AND DUAL POINT WIRING OPTIONS**

THIS PAGE INTENTIONALLY LEFT BLANK

# PUMP WIRING

035-21583-105 REV E

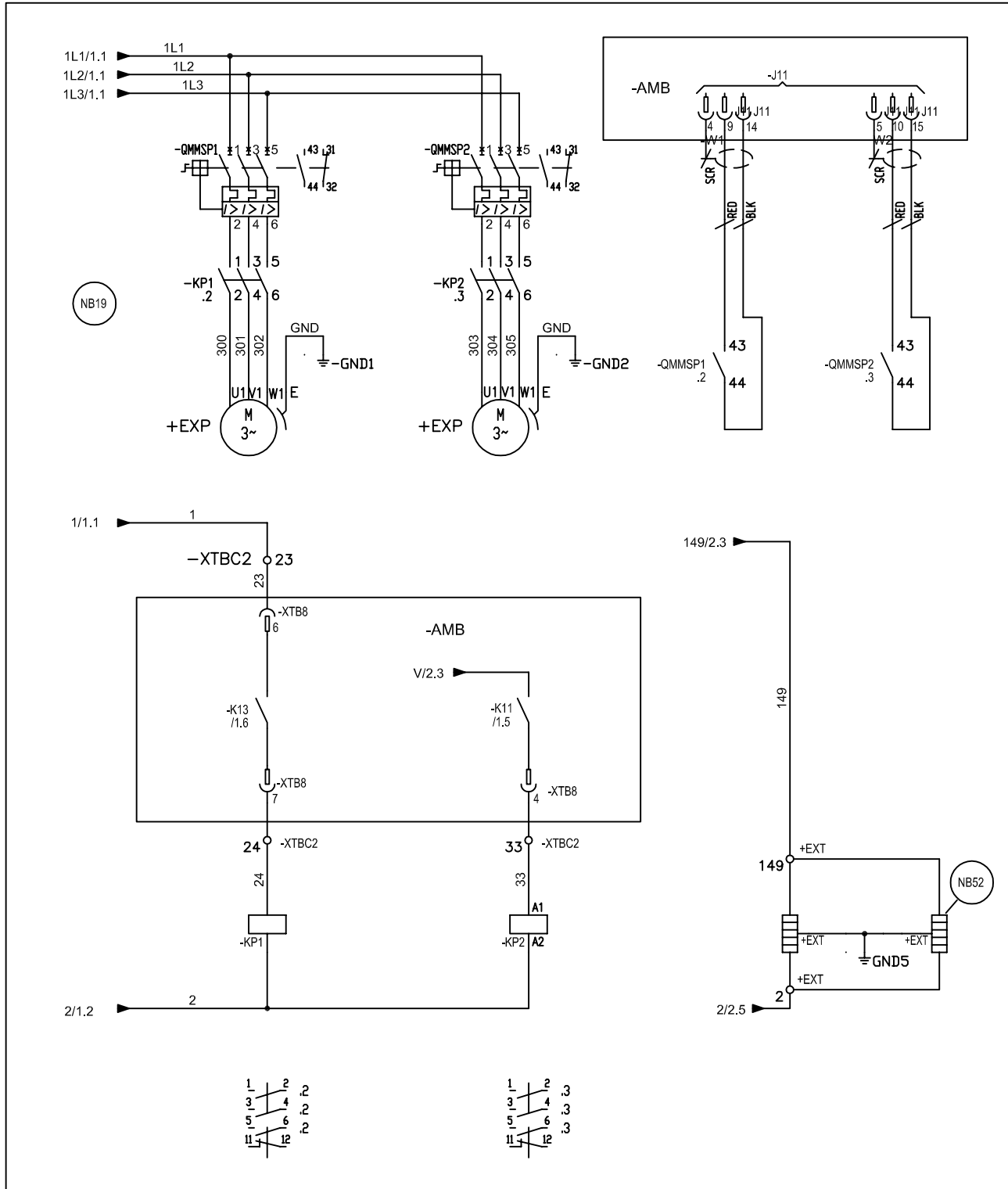

DWG. 5

FIGURE 19 - PUMP WIRING

# PUMP WIRING

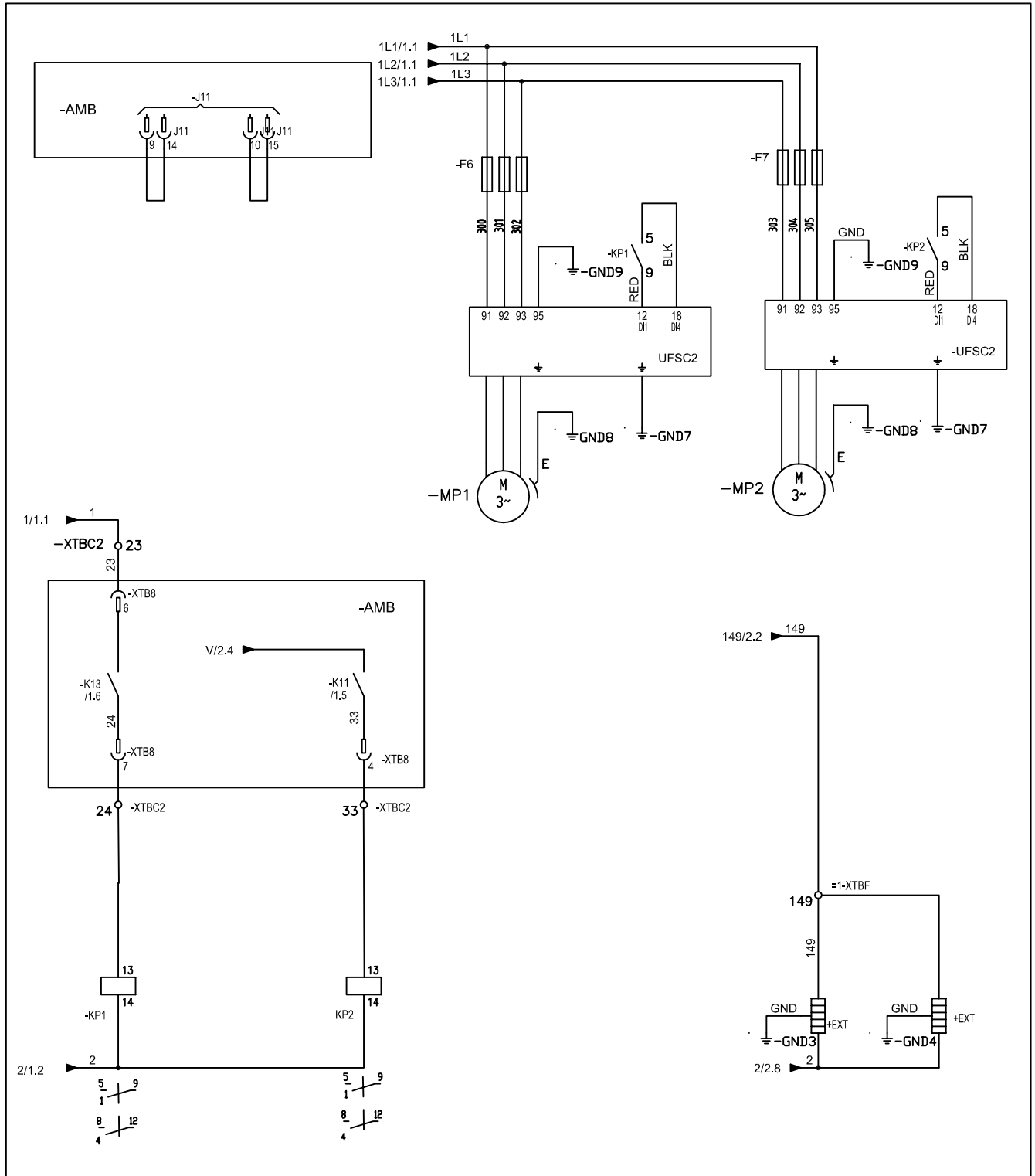

5

DWG. 5

FIGURE 19 - PUMP WIRING

# COMPRESSOR WIRING

035-21589-106 REV N

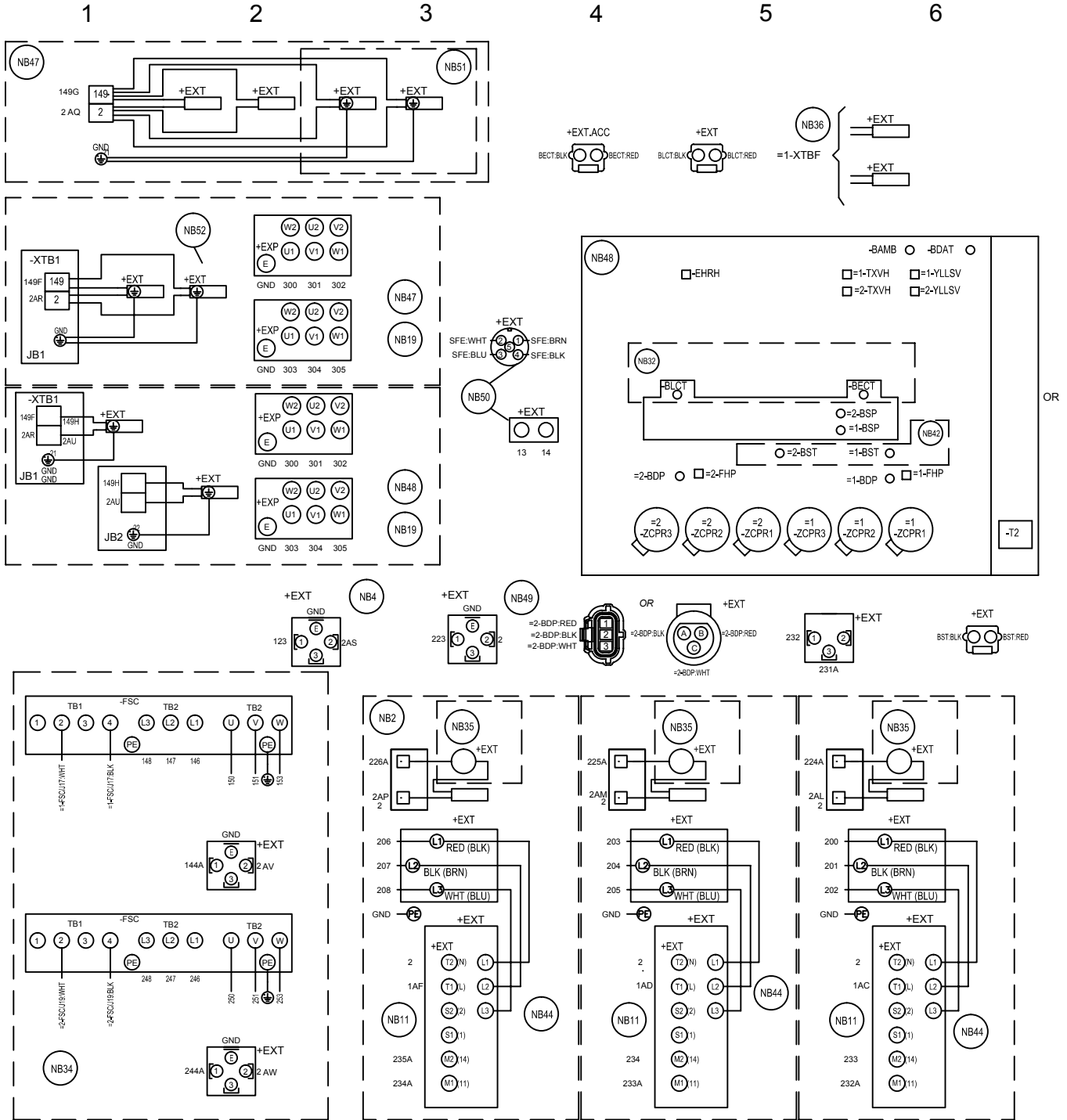

LD21209

FIGURE 20 - COMPRESSOR WIRING

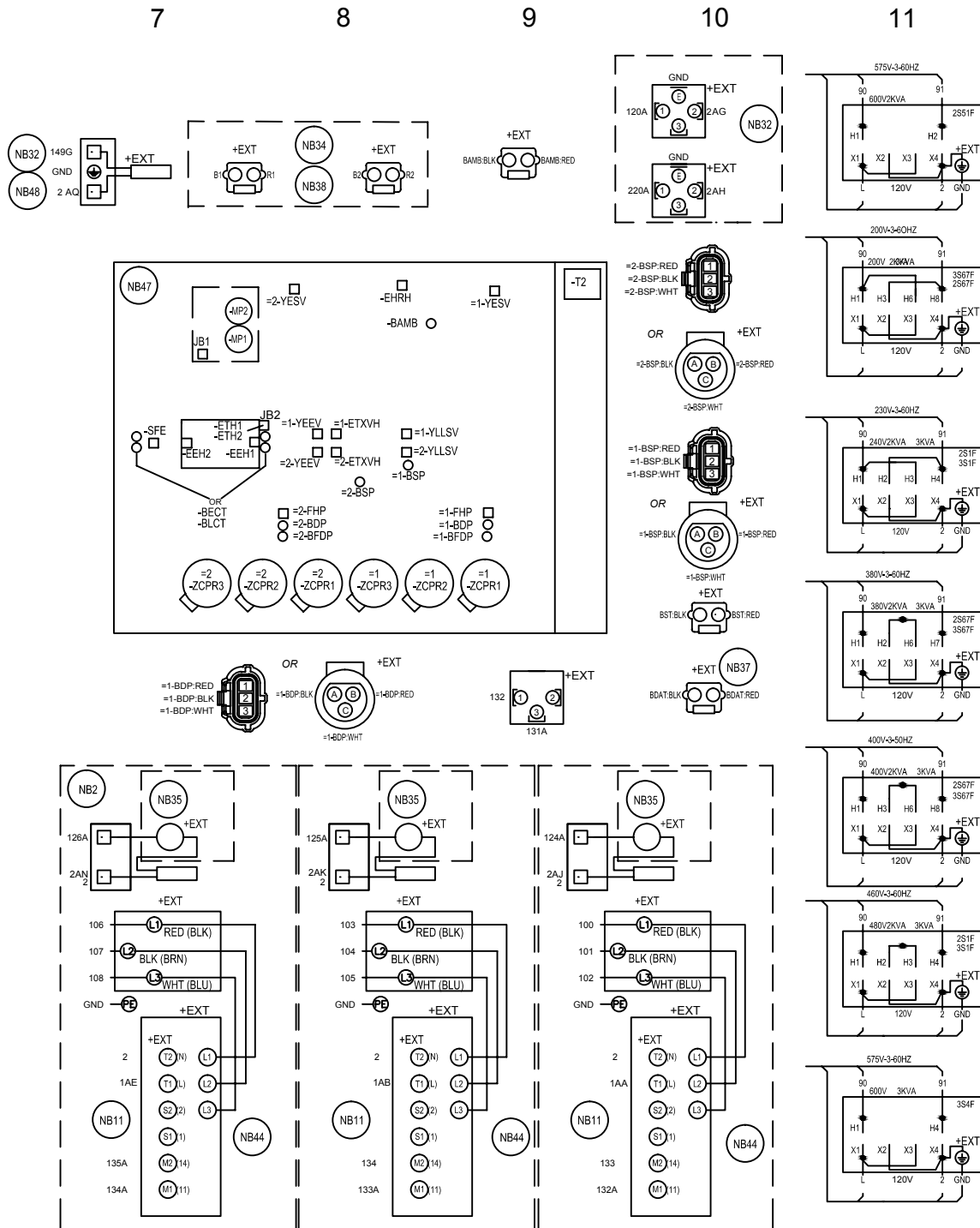

5

FIGURE 20 - COMPRESSOR WIRING (CONT'D)

LD21210

# POWER OPTIONS CONNECTION DIAGRAM

035-21589-103 REV C

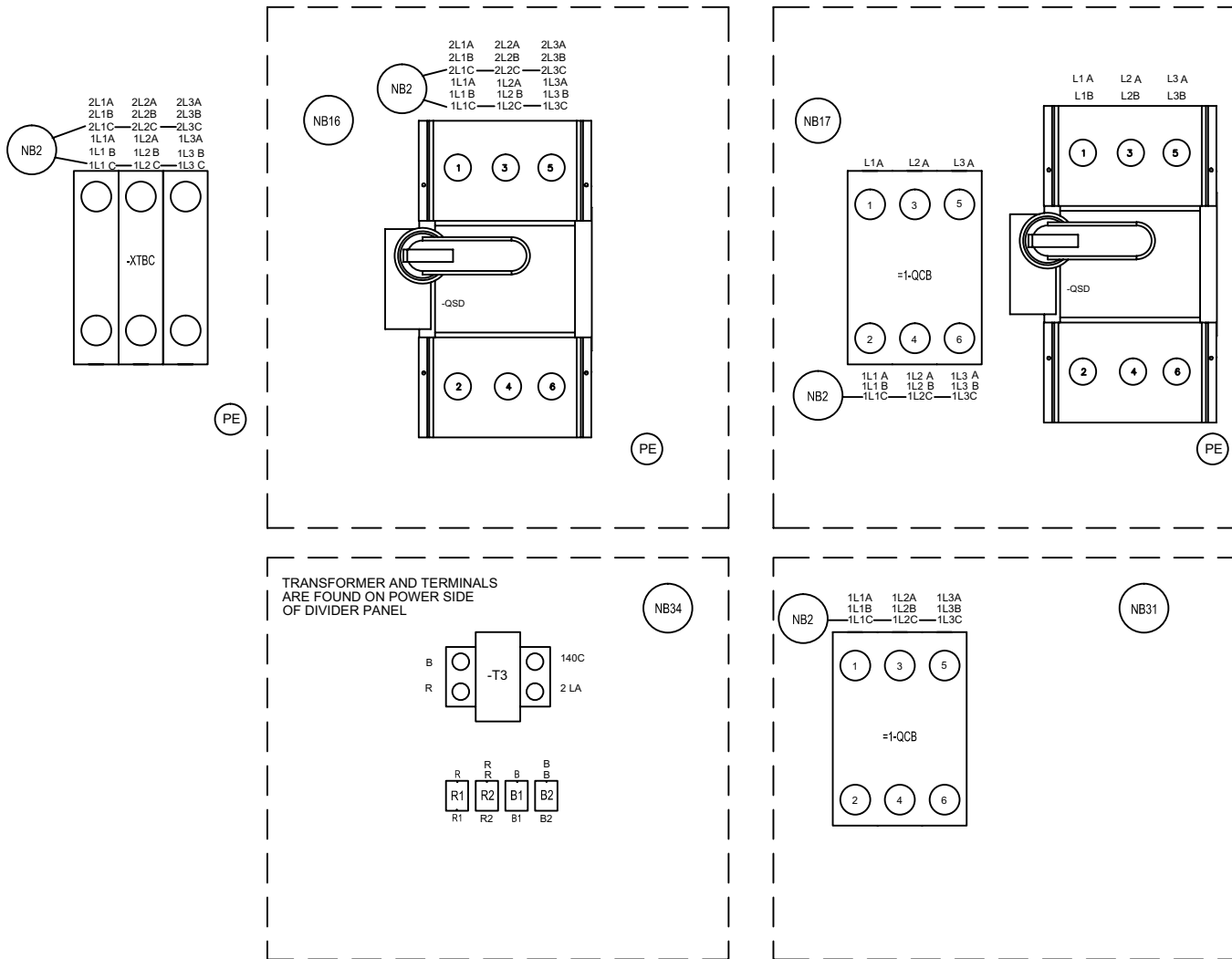

LD13234C

FIGURE 21 - POWER OPTIONS CONNECTION DIAGRAM

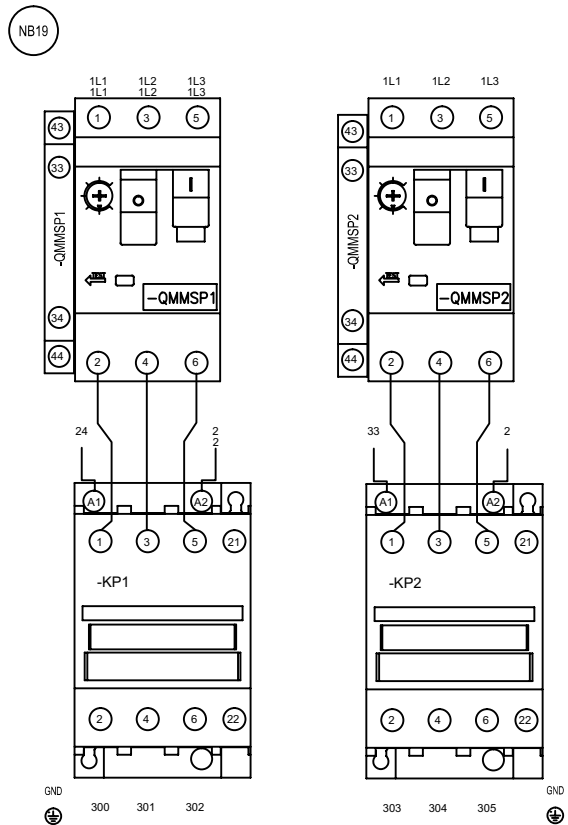
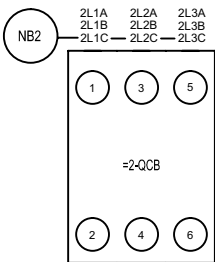
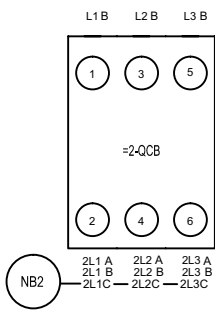

LD13234D

FIGURE 21 - POWER OPTIONS CONNECTION DIAGRAM (CONT'D)

# POWER PANEL

035-21589-101 REV H

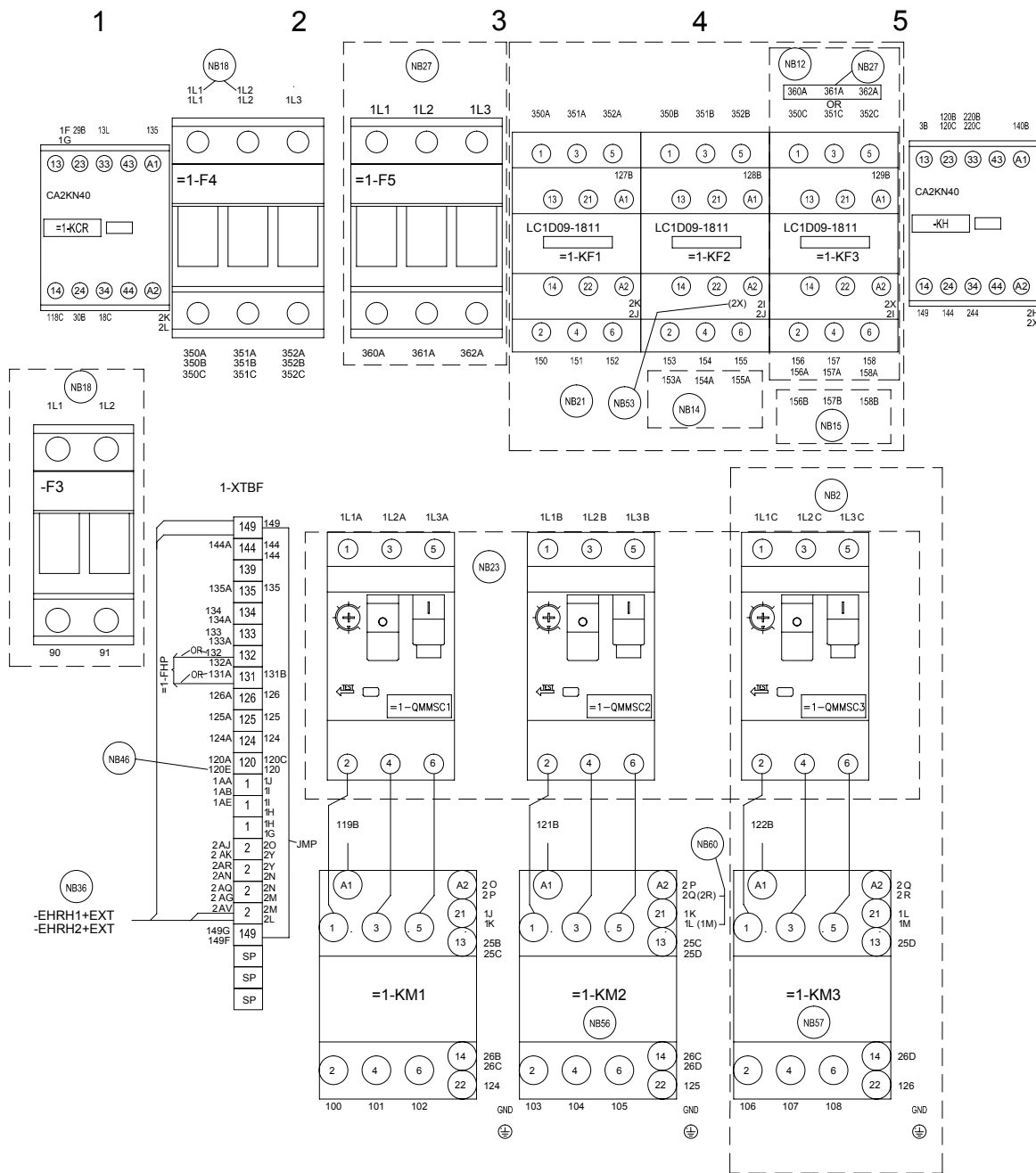

LD16754

FIGURE 22 - POWER PANEL

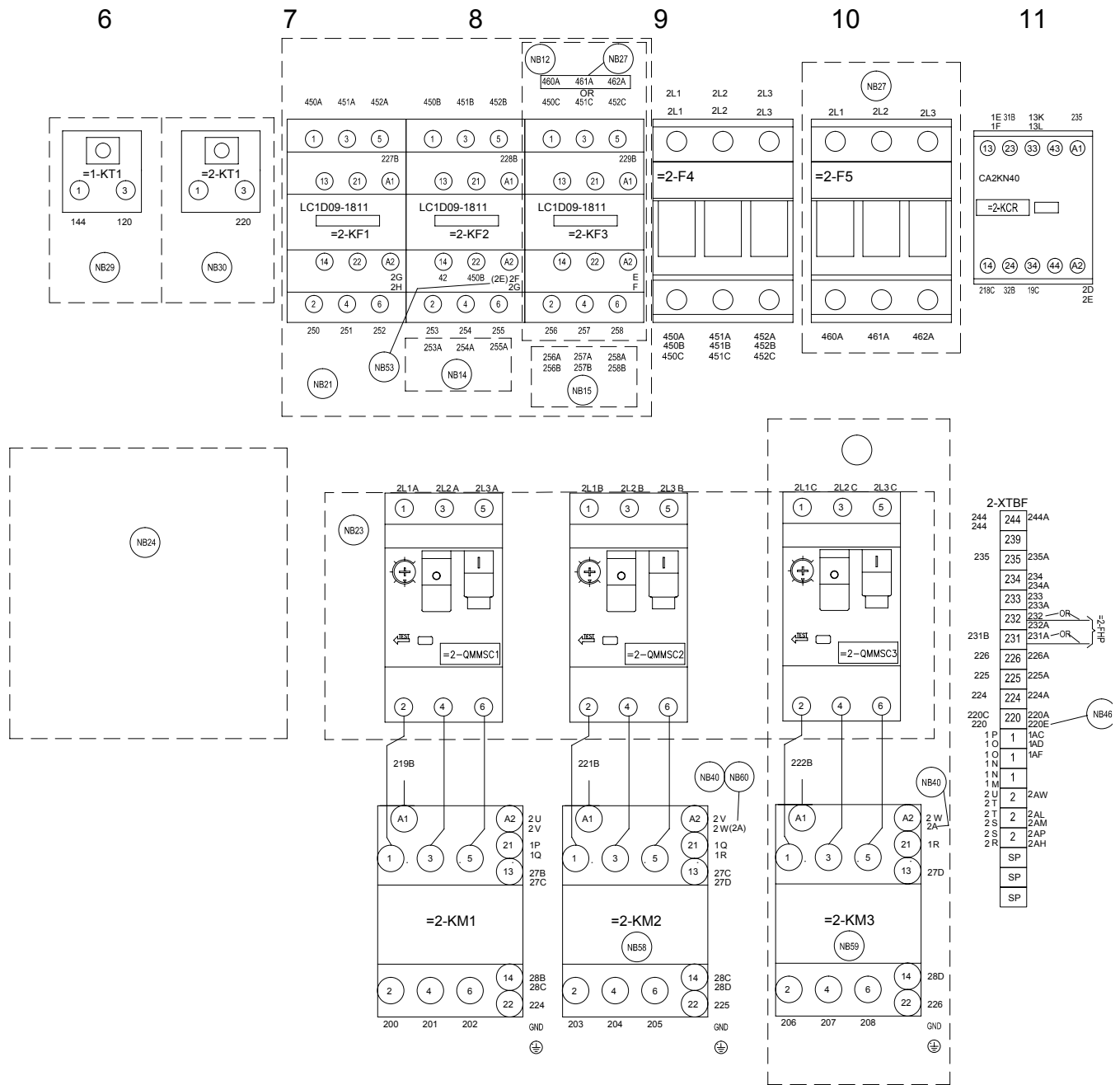

5

FIGURE 22 - POWER PANEL (CONT'D)

# MICRO PANEL CONNECTIONS

035-21589-102 REV M

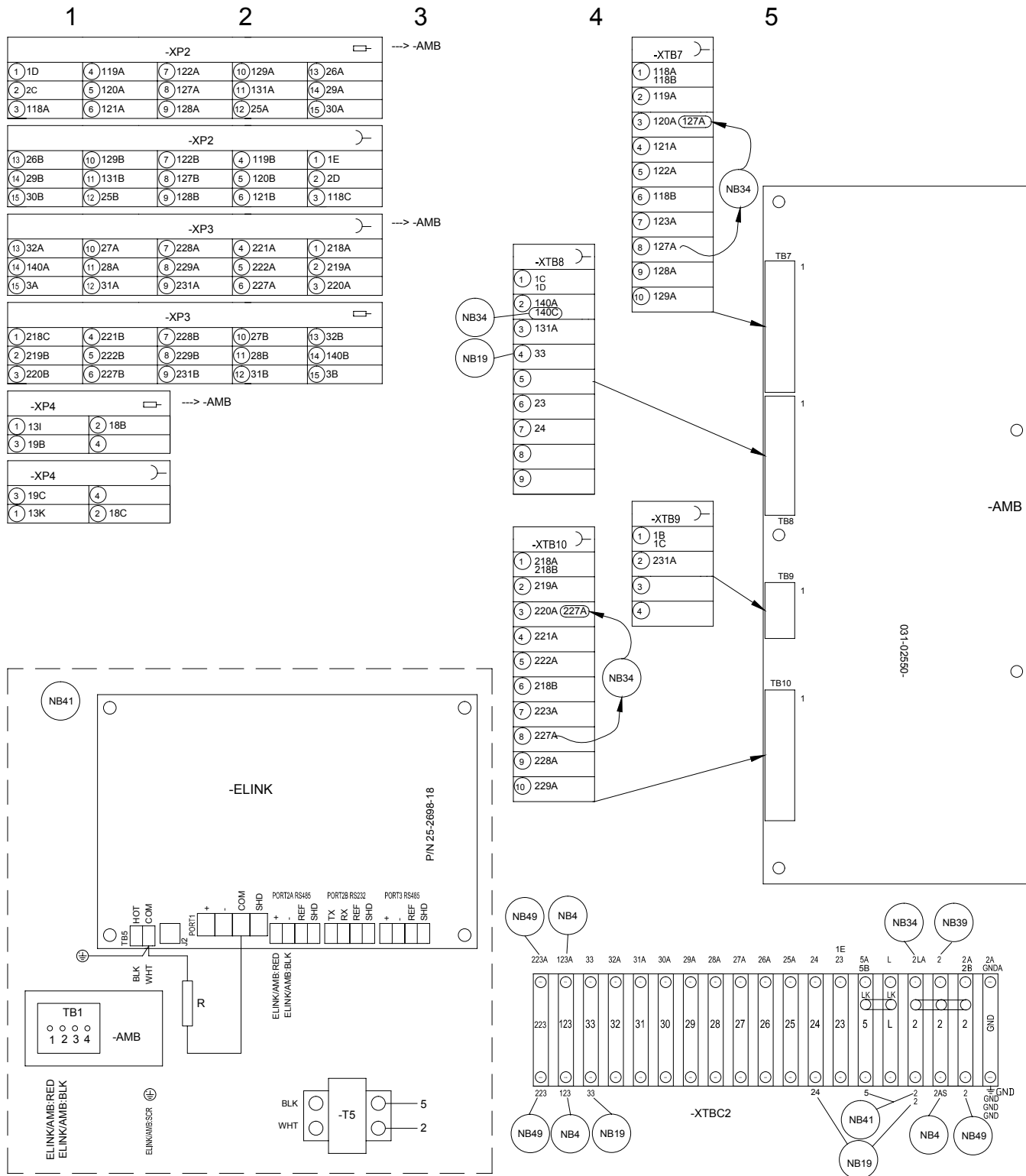
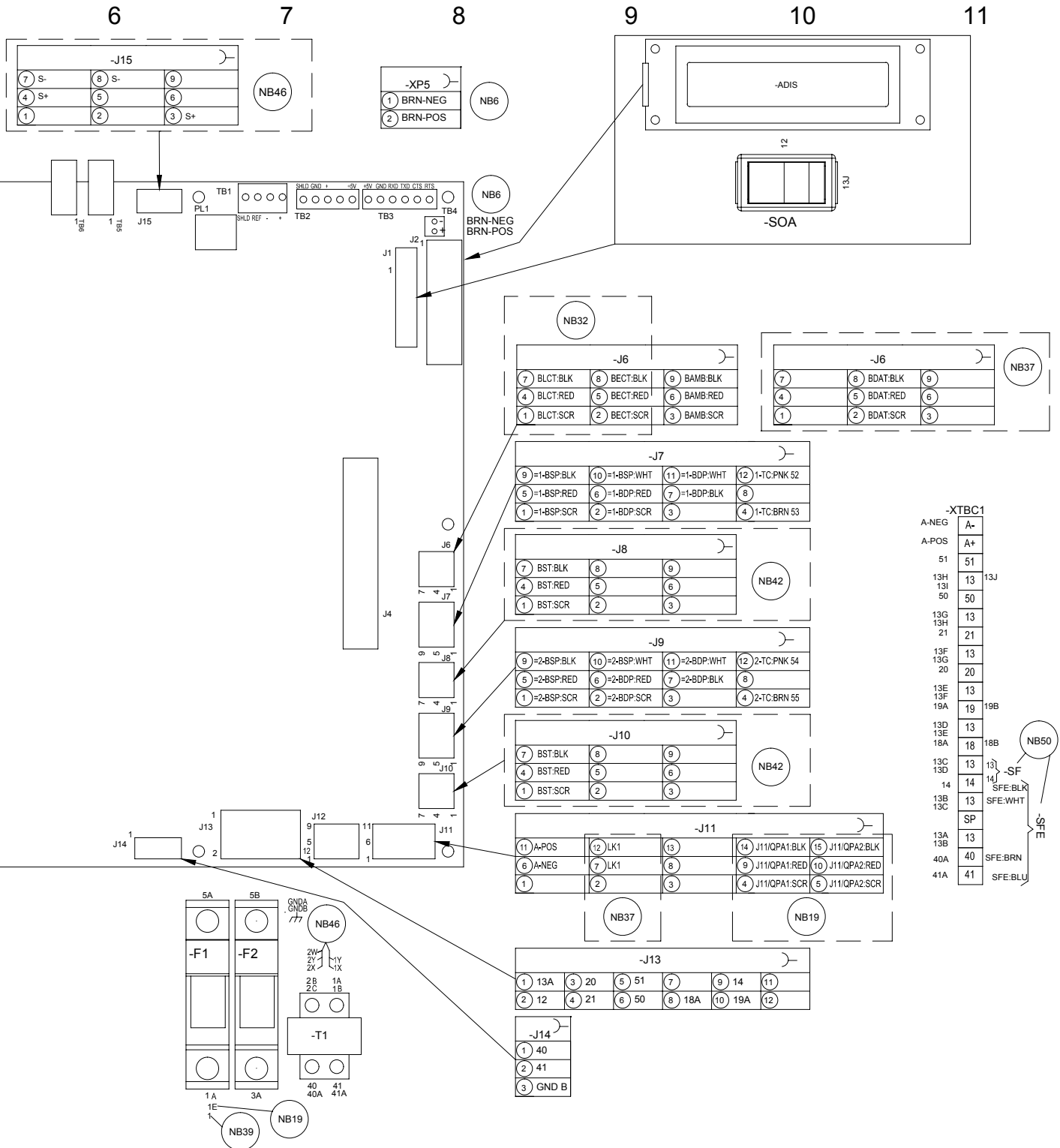

FIGURE 23 - MICRO PANEL CONNECTIONS



5

FIGURE 23 - MICRO PANEL CONNECTIONS (CONT'D)

## FOUR FAN UNITS

### DIMENSIONS – YLAA0058HE, YLAA0065HE, YLAA0081HE

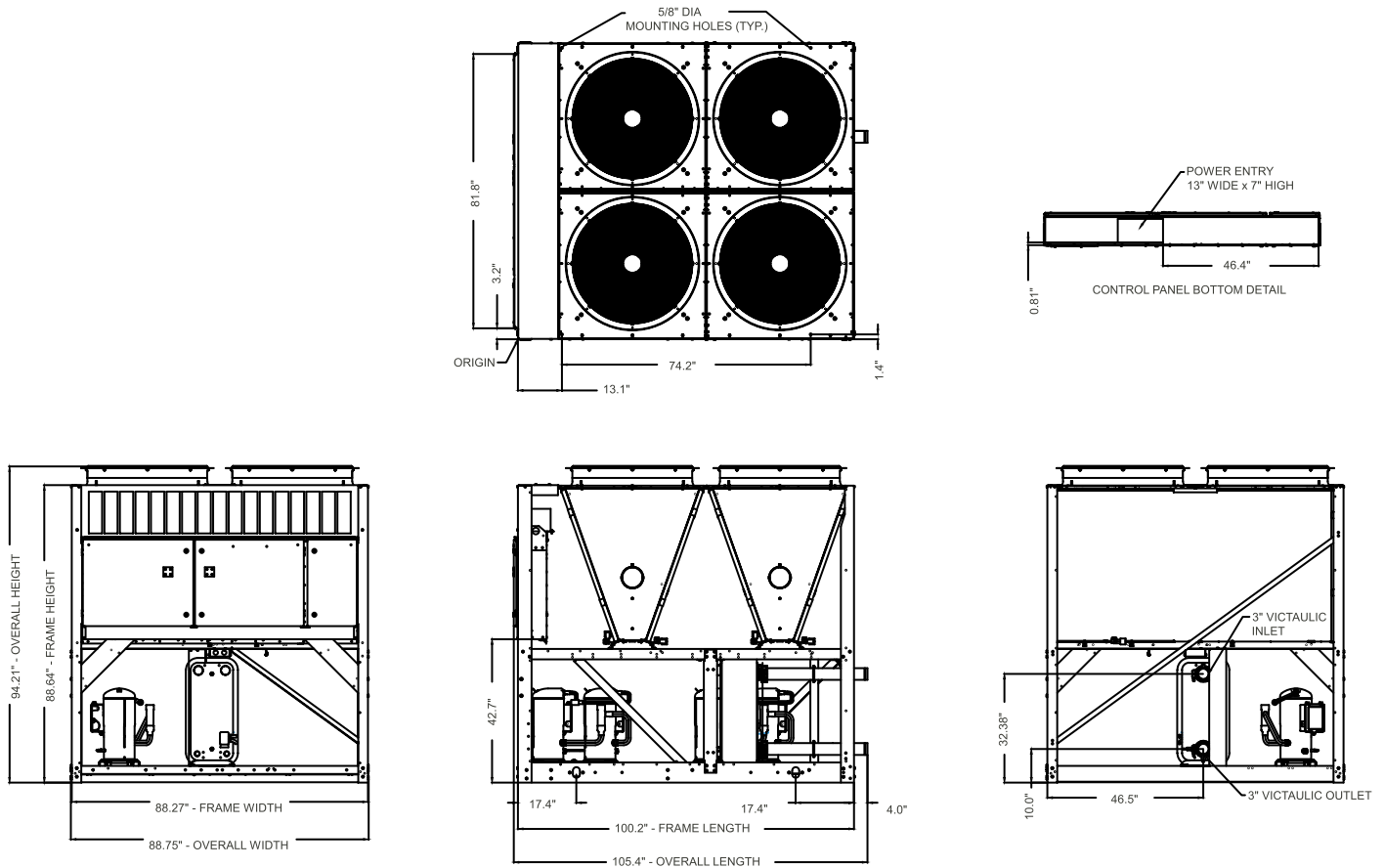

LD18072

**NOTE:**

Placement on a level surface of free of obstructions (including snow, for winter operation) or air circulation ensures rated performance, reliable operation, and ease of maintenance. Site restrictions may compromise minimum clearances indicated below, resulting in unpredictable airflow patterns and possible diminished performance. Johnson Control's unit controls will optimize operation without nuisance high-pressure safety cutouts; however, the system designer must consider potential performance degradation. Access to the unit control center assumes the unit is no higher than on spring isolators. Recommended minimum clearances: Side to wall – 6"; rear to wall – 6"; control panel to end wall – 4'0"; top – no obstructions allowed; distance between adjacent units – 10'. No more than one adjacent wall may be higher than the unit.

**FIGURE 24 - FOUR FAN UNITS DIMENSIONS – YLAA0058HE, YLAA0065HE, YLAA0081HE**

## FOUR FAN UNITS

### DIMENSIONS – YLAA0070SE, YLAA0080SE, YLAA0089SE

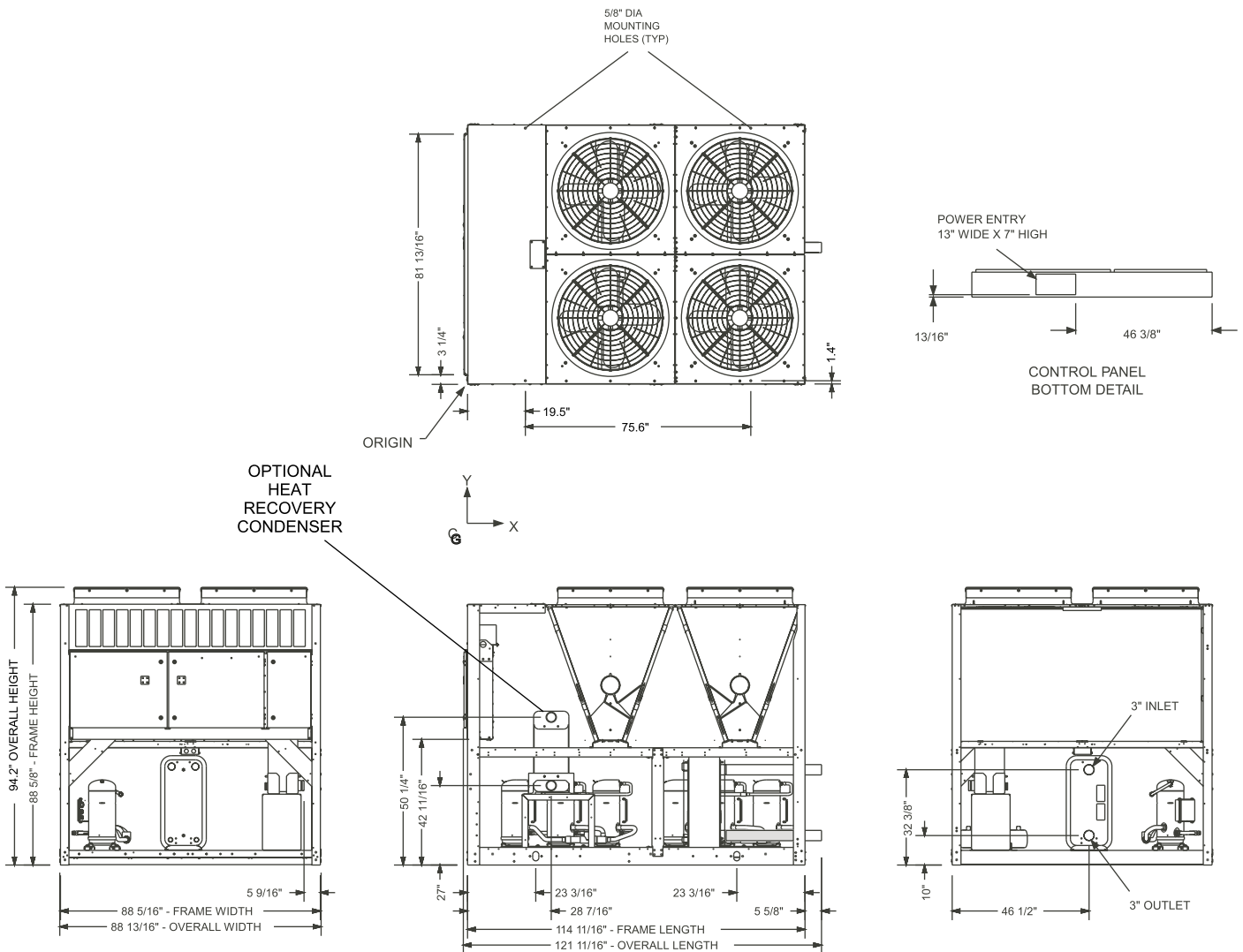

5

LD18073

**NOTE:**

Placement on a level surface of free of obstructions (including snow, for winter operation) or air circulation ensures rated performance, reliable operation, and ease of maintenance. Site restrictions may compromise minimum clearances indicated below, resulting in unpredictable airflow patterns and possible diminished performance. Johnson Control's unit controls will optimize operation without nuisance high-pressure safety cutouts; however, the system designer must consider potential performance degradation. Access to the unit control center assumes the unit is no higher than on spring isolators. Recommended minimum clearances: Side to wall – 6'; rear to wall – 6'; control panel to end wall – 4'0"; top – no obstructions allowed; distance between adjacent units – 10'. No more than one adjacent wall may be higher than the unit.

**FIGURE 25 - FOUR FAN UNITS DIMENSIONS – YLAA0070SE, YLAA0080SE, YLAA0089SE**

## FIVE FAN UNITS DIMENSIONS – YLAA0100SE

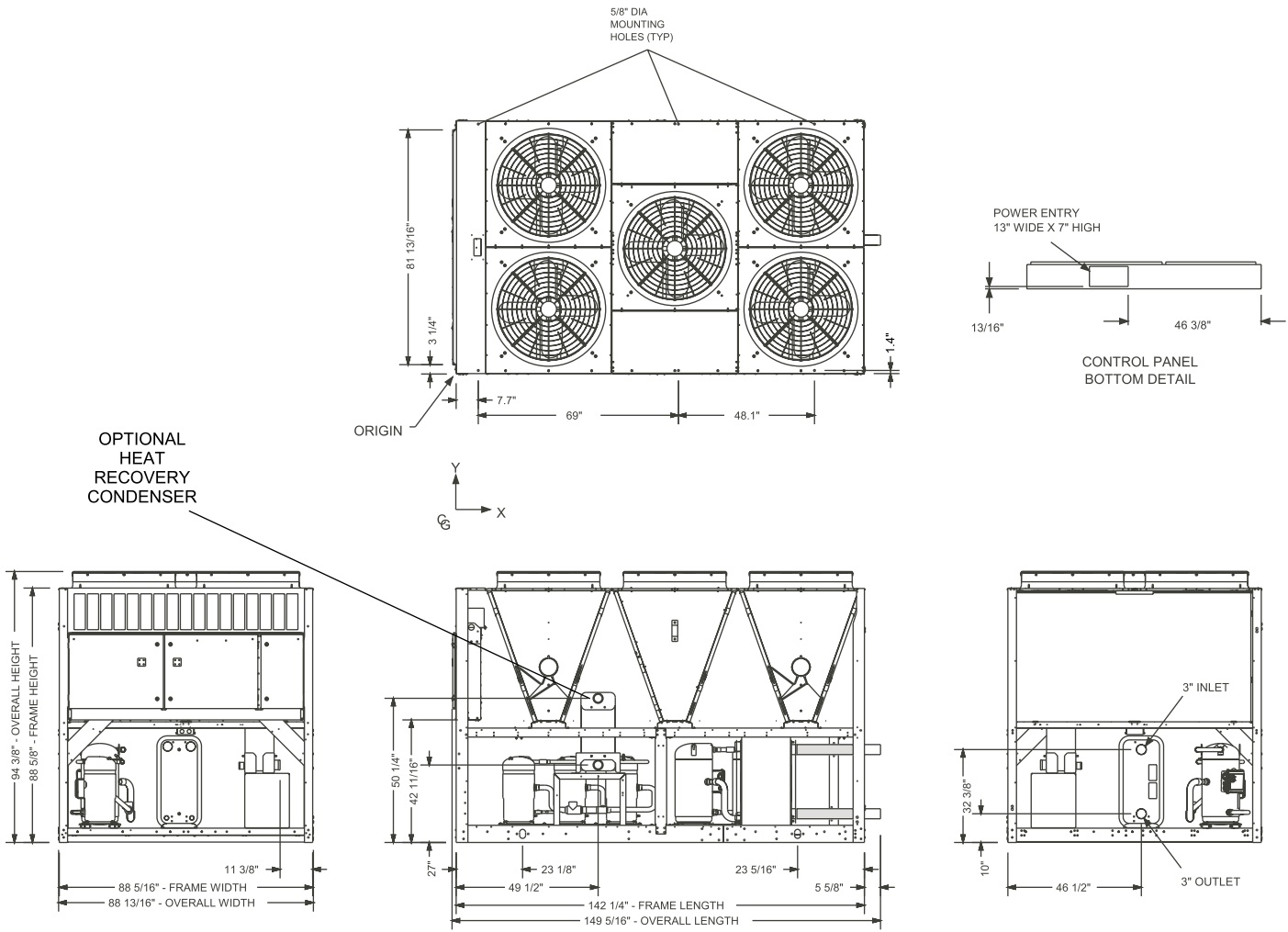

LD18074

**NOTE:**

Placement on a level surface of free of obstructions (including snow, for winter operation) or air circulation ensures rated performance, reliable operation, and ease of maintenance. Site restrictions may compromise minimum clearances indicated below, resulting in unpredictable airflow patterns and possible diminished performance. Johnson Control's unit controls will optimize operation without nuisance high-pressure safety cutouts; however, the system designer must consider potential performance degradation. Access to the unit control center assumes the unit is no higher than on spring isolators. Recommended minimum clearances: Side to wall – 6'; rear to wall – 6'; control panel to end wall – 4'0"; top – no obstructions allowed; distance between adjacent units – 10'. No more than one adjacent wall may be higher than the unit.

**FIGURE 26 - FIVE FAN UNITS DIMENSIONS – YLAA0100SE**

## SIX FAN UNITS

### DIMENSIONS – YLAA0120SE, YLAA0092HE, YLAA0101HE

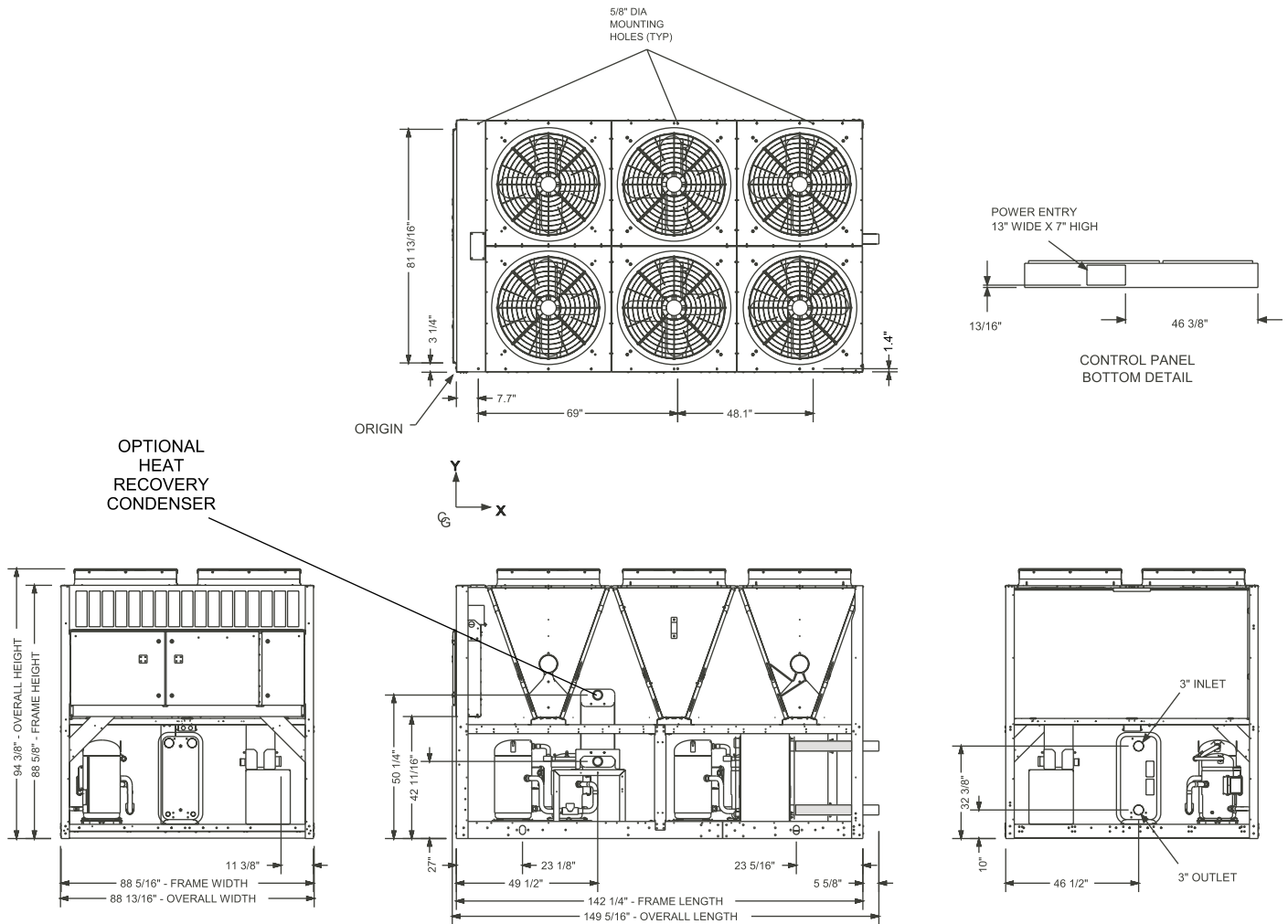

5

**NOTE:**

Placement on a level surface of free of obstructions (including snow, for winter operation) or air circulation ensures rated performance, reliable operation, and ease of maintenance. Site restrictions may compromise minimum clearances indicated below, resulting in unpredictable airflow patterns and possible diminished performance. Johnson Control's unit controls will optimize operation without nuisance high-pressure safety cutouts; however, the system designer must consider potential performance degradation. Access to the unit control center assumes the unit is no higher than on spring isolators. Recommended minimum clearances: Side to wall – 6'; rear to wall – 6'; control panel to end wall – 4'0"; top – no obstructions allowed; distance between adjacent units – 10'. No more than one adjacent wall may be higher than the unit.

**FIGURE 27 - SIX FAN UNITS DIMENSIONS – YLAA0120SE, YLAA0092HE, YLAA0101HE**

# EIGHT FAN UNITS

## DIMENSIONS – YLAA0136SE, YLAA0155SE, YLAA0142HE

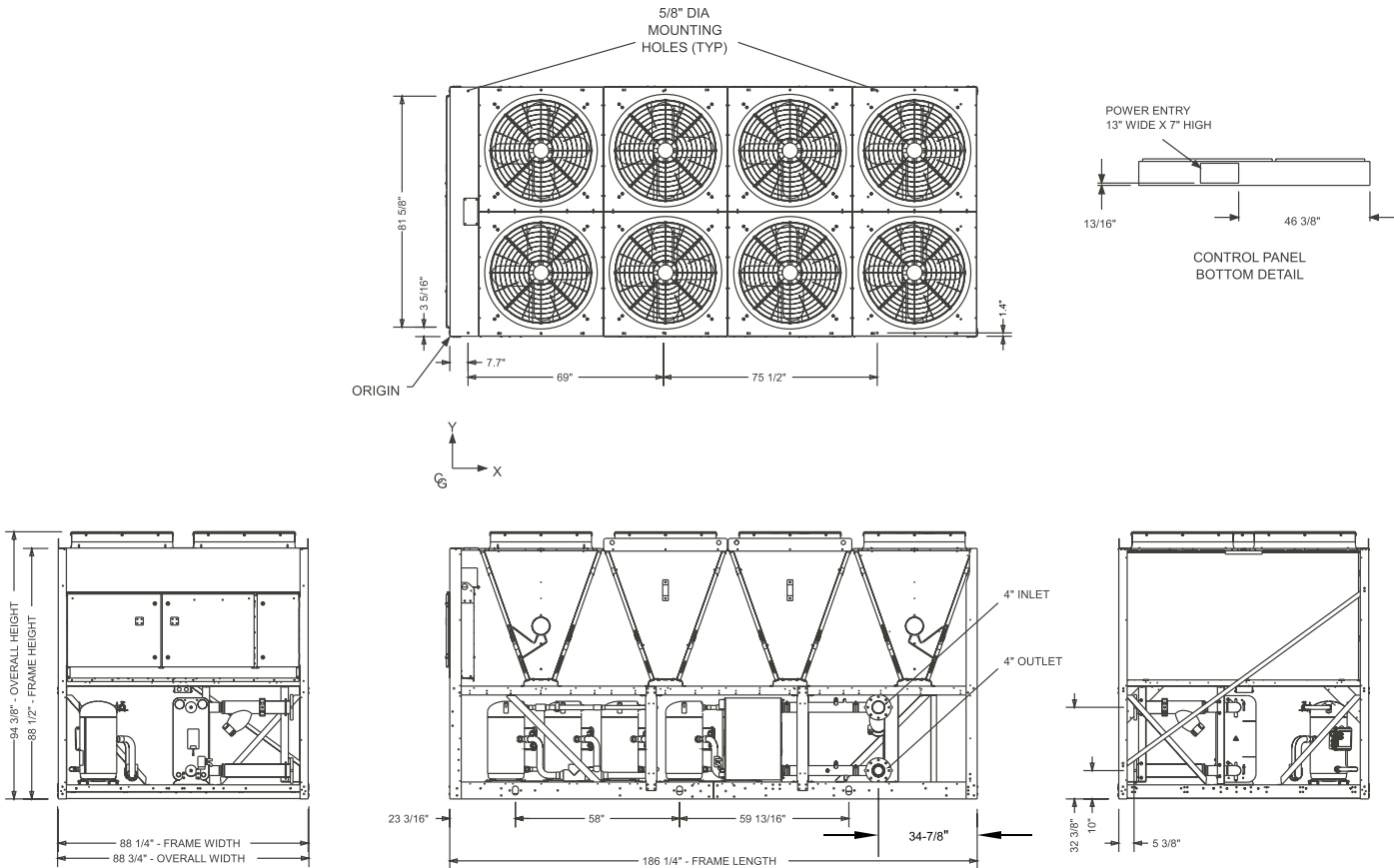

LD18076

**NOTE:**

Placement on a level surface of free of obstructions (including snow, for winter operation) or air circulation ensures rated performance, reliable operation, and ease of maintenance. Site restrictions may compromise minimum clearances indicated below, resulting in unpredictable airflow patterns and possible diminished performance. Johnson Control's unit controls will optimize operation without nuisance high-pressure safety cutouts; however, the system designer must consider potential performance degradation. Access to the unit control center assumes the unit is no higher than on spring isolators. Recommended minimum clearances: Side to wall – 6'; rear to wall – 6'; control panel to end wall – 4'0"; top – no obstructions allowed; distance between adjacent units – 10'. No more than one adjacent wall may be higher than the unit.

**FIGURE 28 - EIGHT FAN UNITS DIMENSIONS – YLAA0136SE, YLAA0155SE, YLAA0142HE**

## TEN FAN UNITS

### DIMENSIONS – YLAA0170SE, YLAA0156HE, YLAA0175HE

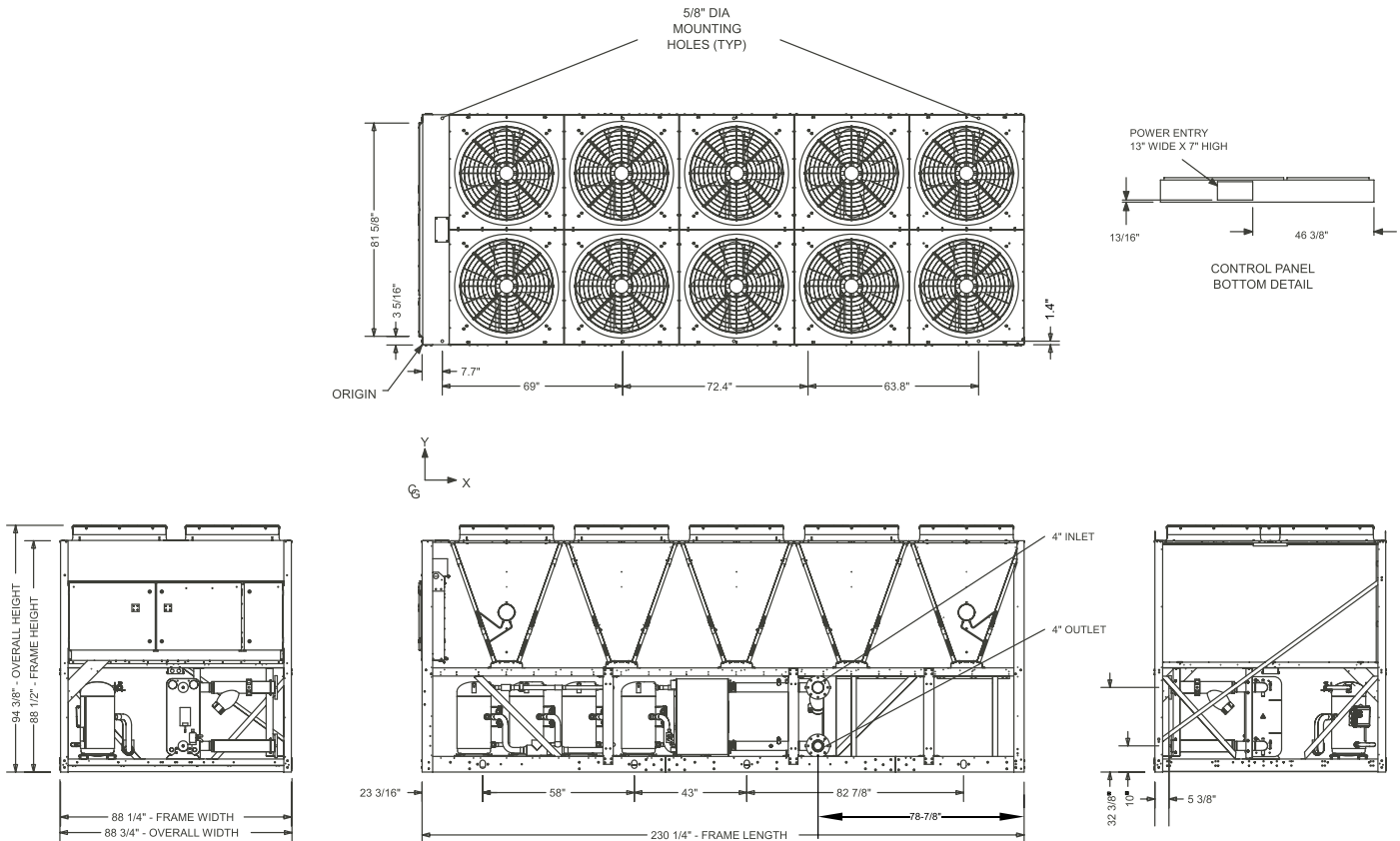

5

**NOTE:**

Placement on a level surface of free of obstructions (including snow, for winter operation) or air circulation ensures rated performance, reliable operation, and ease of maintenance. Site restrictions may compromise minimum clearances indicated below, resulting in unpredictable airflow patterns and possible diminished performance. Johnson Control's unit controls will optimize operation without nuisance high-pressure safety cutouts; however, the system designer must consider potential performance degradation. Access to the unit control center assumes the unit is no higher than on spring isolators. Recommended minimum clearances: Side to wall – 6'; rear to wall – 6'; control panel to end wall – 4'0"; top – no obstructions allowed; distance between adjacent units – 10'. No more than one adjacent wall may be higher than the unit.

**FIGURE 29 - TEN FAN UNITS DIMENSIONS – YLAA0170SE, YLAA0156HE, YLAA0175HE**

# TWELVE FAN UNITS

## DIMENSIONS – YLAA0200HE, YLAA0230HE

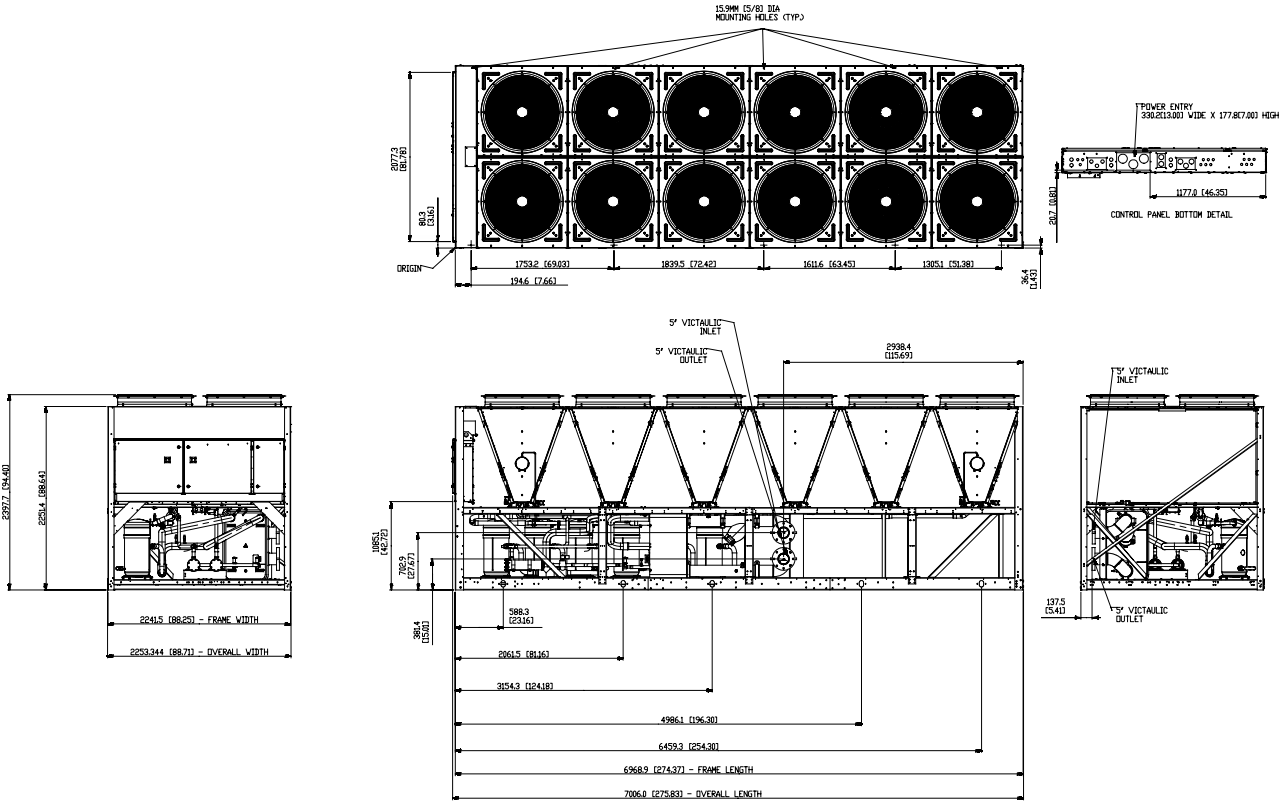

LD21039

**NOTE:**

Placement on a level surface of free of obstructions (including snow, for winter operation) or air circulation ensures rated performance, reliable operation, and ease of maintenance. Site restrictions may compromise minimum clearances indicated below, resulting in unpredictable airflow patterns and possible diminished performance. Johnson Control's unit controls will optimize operation without nuisance high-pressure safety cutouts; however, the system designer must consider potential performance degradation. Access to the unit control center assumes the unit is no higher than on spring isolators. Recommended minimum clearances: Side to wall – 6'; rear to wall – 6'; control panel to end wall – 4'0"; top – no obstructions allowed; distance between adjacent units – 10'. No more than one adjacent wall may be higher than the unit.

**FIGURE 30 - TWELVE FAN UNITS DIMENSIONS**

## WEIGHT DISTRIBUTION AND ISOLATOR MOUNTING POSITIONS

### General

Weights of specific chiller models vary significantly as options are added. As a result, total weights, weights at individual isolator positions, and actual isolator selection at each position cannot be published due to the vast number of possible combinations. This information will be available when the specific chiller/ option selection is made from the local Johnson Controls sales office. Be aware, weights will change with each option along with possible isolator changes. Weights and isolators may need to be recalculated when the option selections are changed.

Whenever the isolator option is ordered, the isolators will be shipped loose with the chiller. Packed with the isolators and also in the control panel information packet is a drawing and table specifically for each chiller, based on the option selection. The drawing and table will be similar to the two samples shown below and on the following page. The drawing will show the isolator locations along with the weight in pounds and kilograms at the specific location, isolator position, and location measurements for each isolator.

### Sample Isolator Location Drawings

See *Figure 31* below for sample printouts supplied in the isolator package and in the chiller panel literature packets.

<b>UNIT SHIPPING WEIGHT</b> (Display on unit data nameplate)	<b>KG</b>	<b>LBS.</b>
	2032	4480

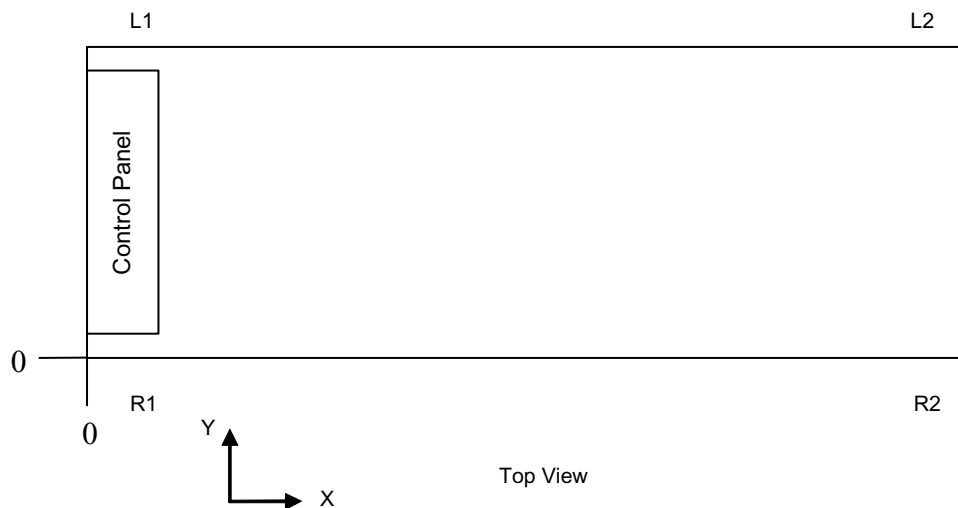

LOCATION	X DISTANCE INCHES (MM)	Y DISTANCE INCHES (MM)	VENDOR NUMBER	OPERATING WEIGHT LBS (KG)
R1	19.5 (495.3)	1.36 (34.5)	ND-D / Yellow	1092 (495.3)
L1	19.5 (495.3)	86.86 (2206.2)	ND-D / Yellow	1406 (637.8)
R2	96.1 (2440.9)	1.36 (34.5)	ND-D / Yellow	1015 (460.4)
L2	96.1 (2440.9)	86.86 (2206.2)	ND-D / Yellow	1304 (591.5)

**FIGURE 31 - SAMPLE PRINTOUT SUPPLIED IN THE ISOLATOR PACKAGE AND IN THE CHILLER PANEL LITERATURE PACKET**

**CLEARANCES**

See *Figure 32* below for minimum clearances for all YLAA units.

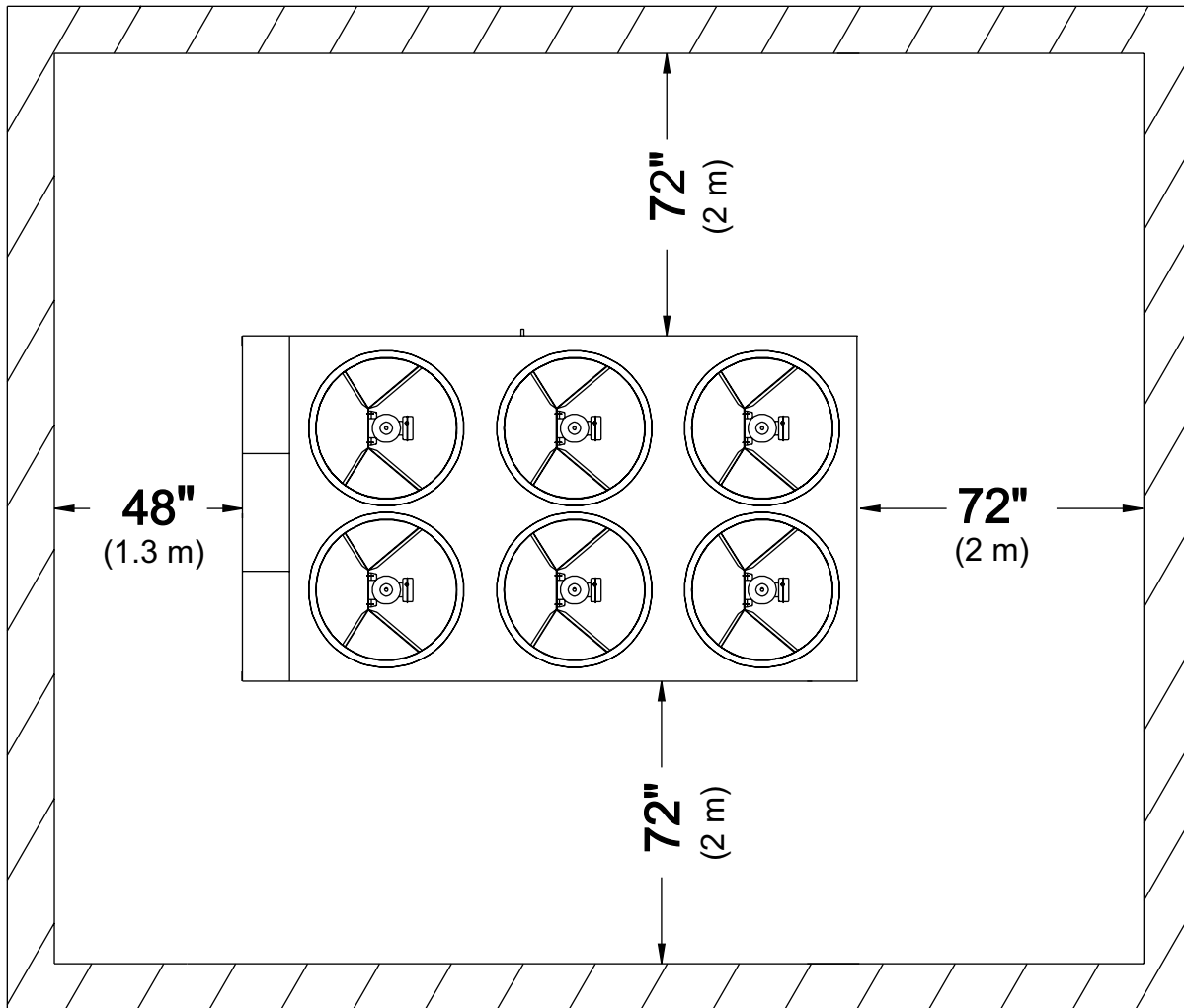
**NOTES:**

1. No obstructions allowed above the unit.
2. Only one adjacent wall may be higher than the unit.
3. Adjacent units should be 10 feet (3 Meters) apart.

**FIGURE 32 - UNIT CLEARANCES – ALL MODELS**

## ISOLATOR LOCATIONS

### FOUR FAN ISOLATOR LOCATIONS YLAA0058HE, YLAA0065HE, YLAA0081HE

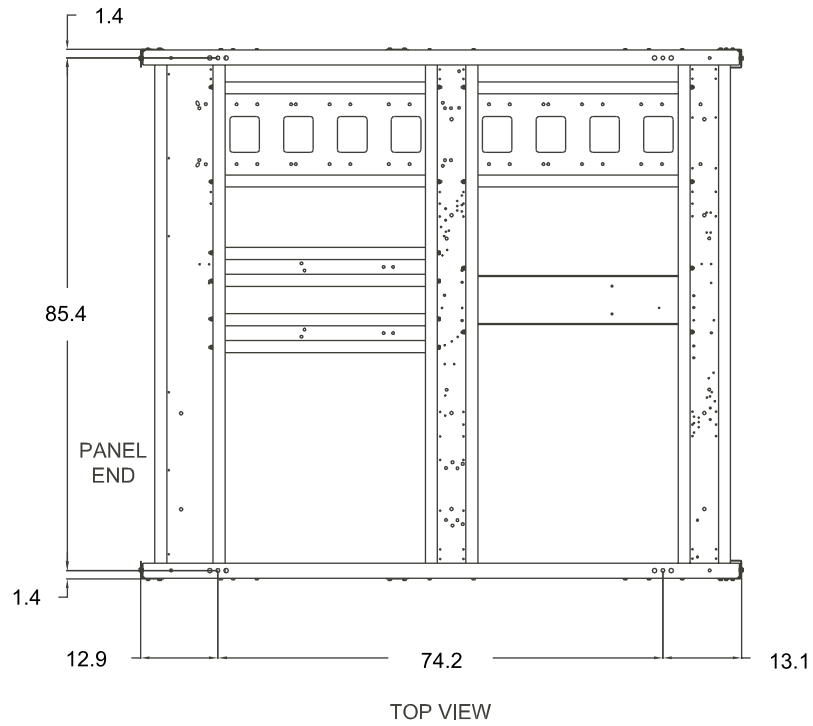

5

LD18078

### FOUR FAN ISOLATOR LOCATIONS YLAA0070SE, YLAA0080SE, YLAA0089SE

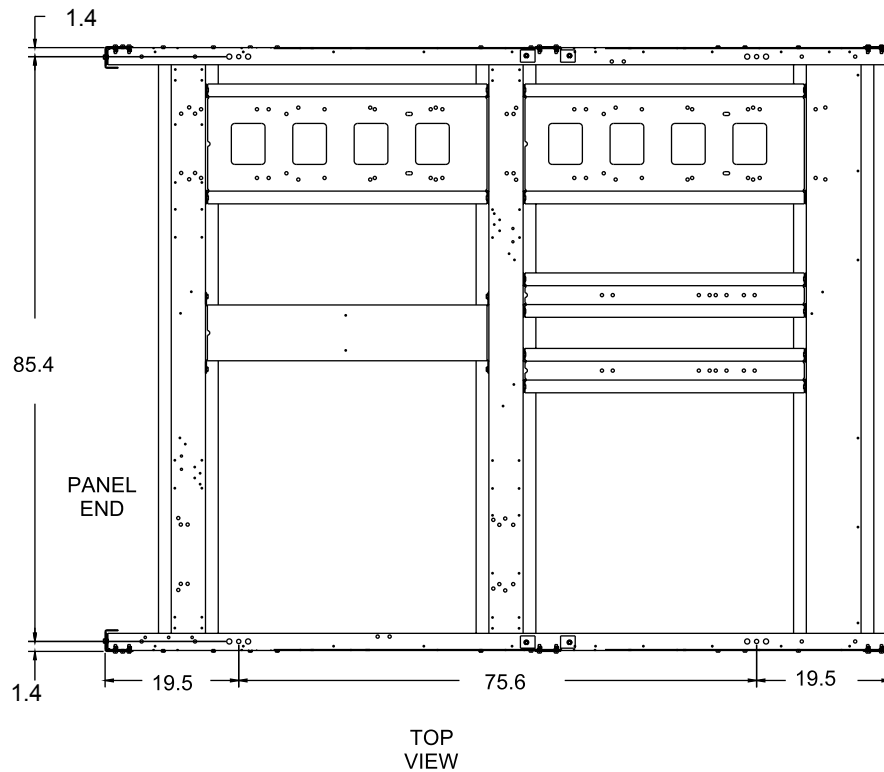

LD18079

All dimensions are inches unless otherwise specified.

**FIVE and SIX FAN ISOLATOR LOCATIONS  
YLAA0100SE, YLAA0120SE, YLAA0092HE, YLAA0101HE**

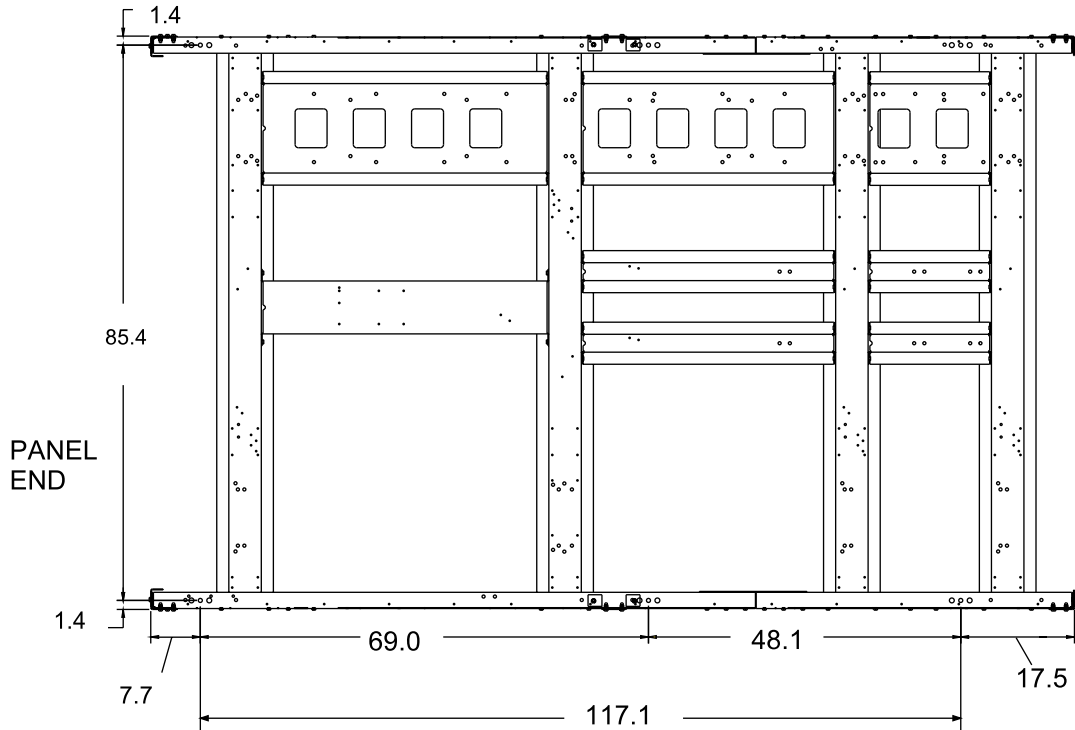

TOP  
VIEW

LD18080

**EIGHT FAN ISOLATOR LOCATIONS YLAA0136SE, YLAA0155SE, YLAA0142HE**

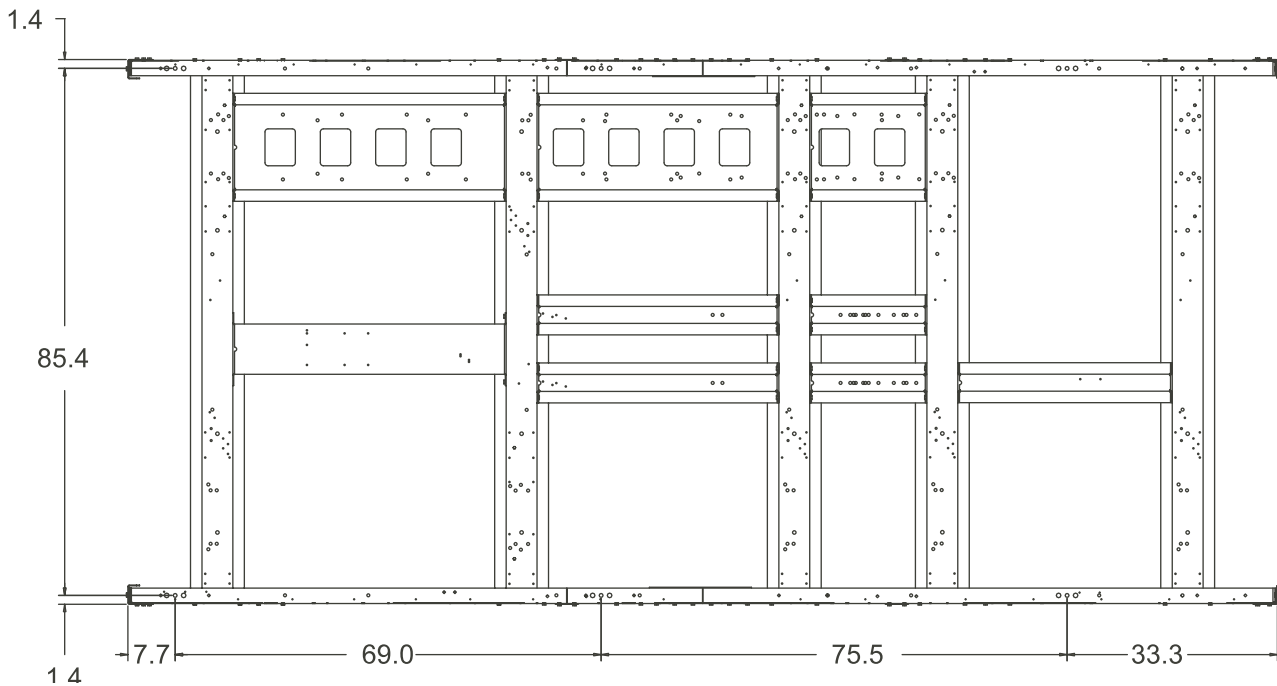

LD18081

All dimensions are inches unless otherwise specified.

**TEN FAN ISOLATOR LOCATIONS YLAA0170SE, YLAA0156HE, YLAA0175HE**

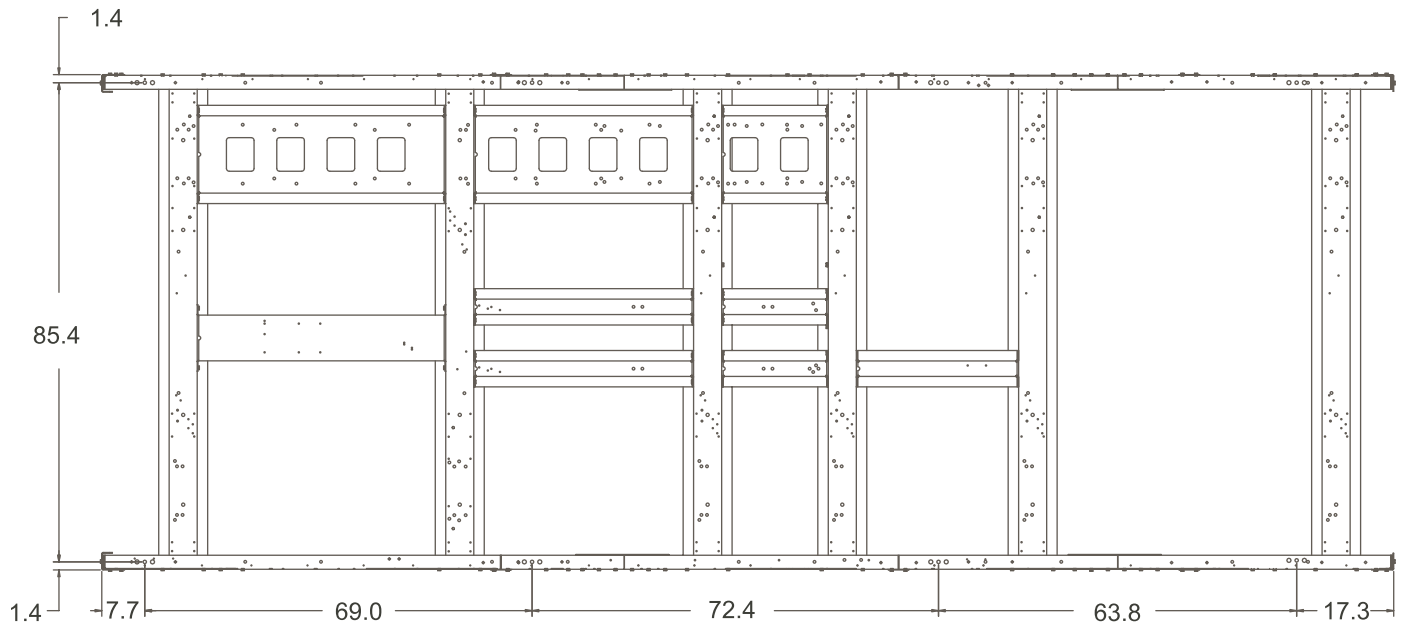

LD18082

**5**

**TWELVE FAN ISOLATOR LOCATIONS YLAA0200HE, YLAA0230HE**

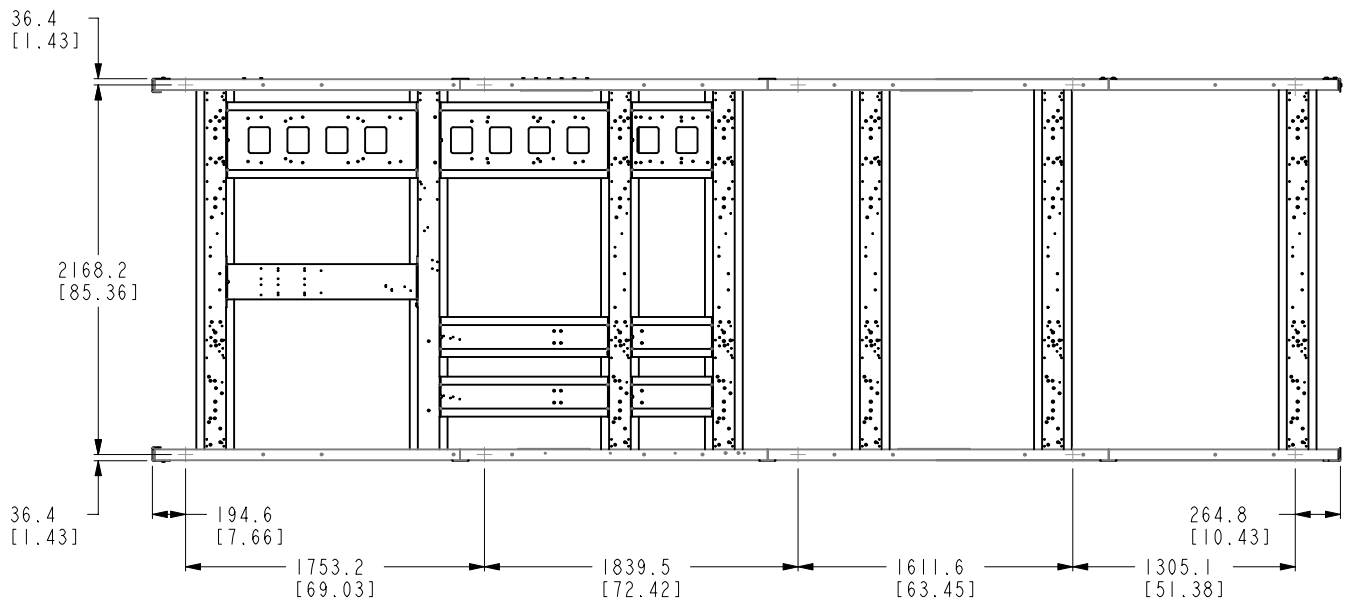

TOP  
 VIEW

LD21040

All dimensions are inches unless otherwise specified.

## ISOLATOR INFORMATION

### One Inch Deflection Spring Isolator Cross-reference

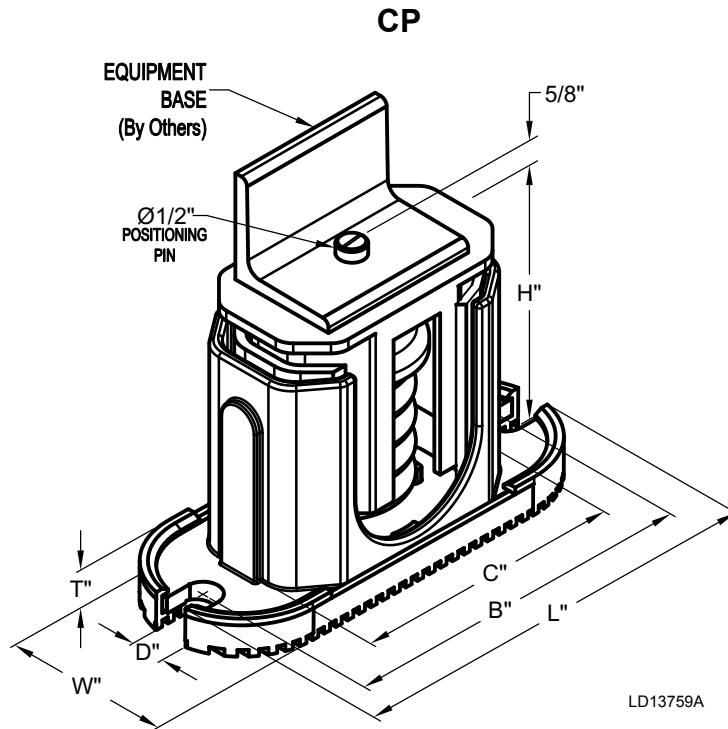

MOUNT TYPE	DIMENSION DATA (INCHES)						
	W	D	L	B	C	T	H
CP1	3	5/8	7-3/4	6-1/2	4-3/4	1/2	5-5/8
CP2	3	5/8	10-1/2	9-1/4	7-3/4	9/16	6

MODEL NUMBER	RATED CAPACITY (LBS)	DEFLECTION RATED (IN)	COLOR CODE
CP1-1D-85	85	1.360	LT. PURPLE
CP1-1D-120	120	1.200	DK. YELLOW
CP1-1D-175	175	1.170	DK. BLUE
CP1-1D-250	250	1.400	YELLOW
CP1-1D-340	340	1.130	RED
CP1-1D-510	510	1.020	BLACK
CP1-1D-675	675	1.320	DK. PURPLE
CP1-1D-900	900	1.020	DK. GREEN
CP1-1D-1200	1200	0.900	GRAY
CP1-1D-1360	1360	0.770	WHITE
CP1-1D-1785N	1785	0.880	GRAY/RED

MODEL NUMBER	RATED CAPACITY (LBS)	DEFLECTION RATED (IN)	COLOR CODE
CP2-1D-1020	1020	1.020	BLACK
CP2-1D-1350	1350	1.320	DK. PURPLE
CP2-1D-1800	1800	1.020	DK. GREEN
CP2-1D-2400	2400	0.900	GRAY
CP2-1D-2720	2720	0.770	WHITE
CP2-1D-3570N	3570	0.880	GRAY / RED

## ONE INCH DEFLECTION SPRING ISOLATORS INSTALLATION INSTRUCTIONS

1. Read instructions in their entirety before beginning installation.
2. Isolators are shipped fully assembled and are to be positioned in accordance with the submittal drawings or as otherwise recommended.
3. Set isolators on floor, housekeeping pad or sub-base, ensuring that all isolators centerlines match the equipment mounting holes. The VMC group recommends that the isolator base ("B") be installed on a level surface. Shim or grout as required, leveling all isolator bases to the same elevation (1/4-inch maximum difference can be tolerated).
4. Bolt or anchor all isolators to supporting structure utilizing base slotted holes ("C").
5. Place equipment on top of isolators making sure that mounting holes of the equipment line up with isolator positioning pin ("H").
6. The adjustment process can only begin after the equipment or machine is at its full operating weight.
7. Adjust each isolator in sequence by turning spring adjusting bolt ("D") one full counterclockwise turn at a time. Repeat this procedure on all isolators, one at a time.
8. Continue adjusting each isolator until a minimum of 1/4" clearance is achieved between the lower housing and upper housing. (See drawing below).
9. Fine adjust isolators to level equipment.
10. Installation is complete.

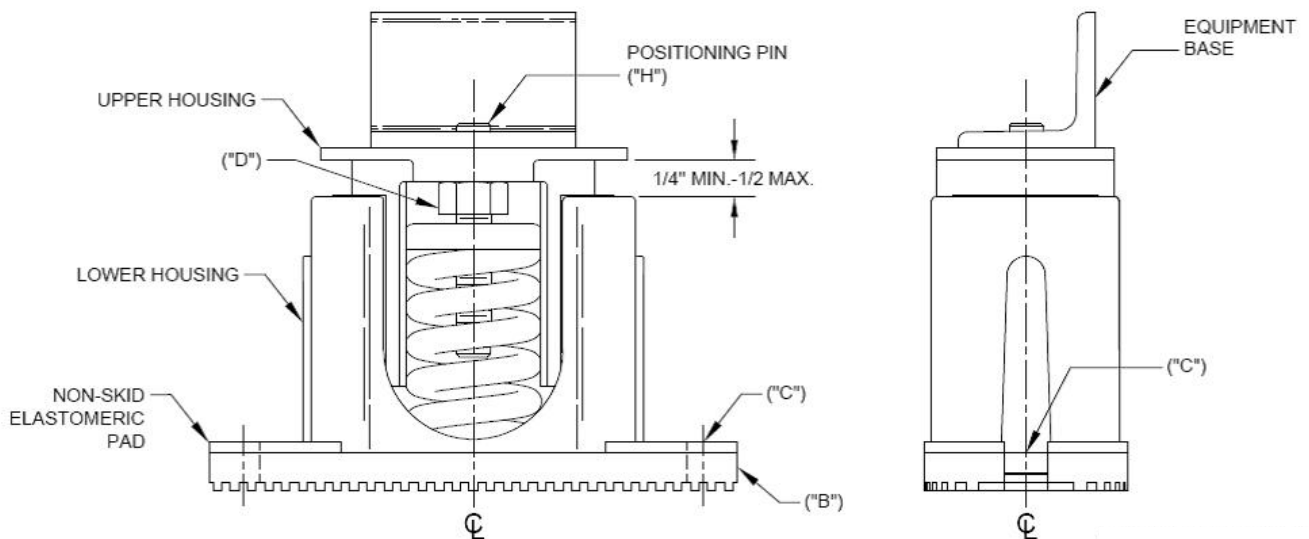

LD13790

## 2" DEFLECTION ISOLATOR CROSS-REFERENCE

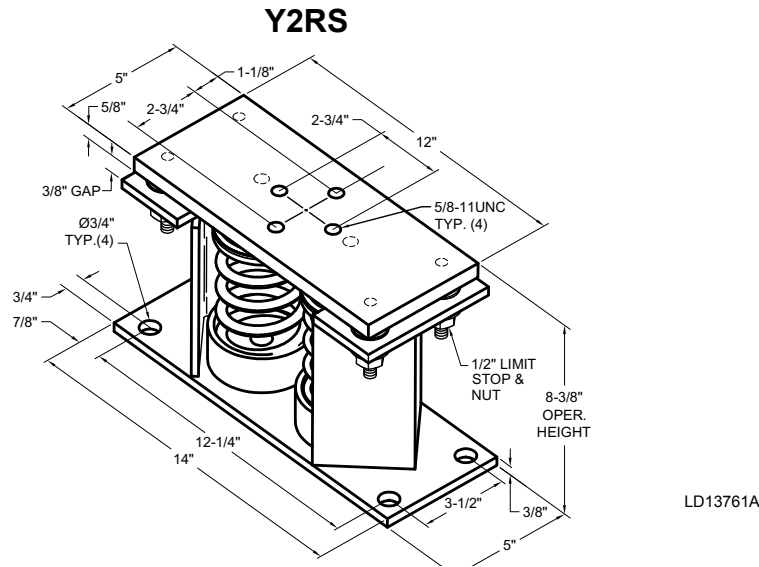

1. All dimensions are in inches, interpret per ANSI Y14.
2. Standard finish: housing-powder coated (color, black), spring-powder coated (color, see table below) hardware - zinc-electroplate.
3. Equipment must be bolted or welded to the top plate to meet allowable seismic ratings.
4. All springs are designed for 50% overload capacity with exception of the 2D-3280N and 2D-2870.
5. See next page for installation instructions.
6. Consult factory for concrete installation.

**MODEL Y2RSI-2D SEISMICALLY RESTRAINED VIBRATION ISOLATOR FOR 2" DEFLECTION**

SEISMIC MOUNT SIZE	RATED LOAD (LBS)	RATED DEFLECTION (IN)	SPRING RATE (LBS/IN)	SOLID LOAD (LBS)	COLOR CODE	ALLOWABLE G RATING HORIZONTAL
Y2RSI-2D-150	150	2.4	62	234	WHITE	34.7
Y2RSI-2D-320	320	2.3	140	490	YELLOW	16.3
Y2RSI-2D-460	460	2.3	200	688	GREEN	11.3
Y2RSI-2D-710	710	2.2	330	1072	DK BROWN	7.3
Y2RSI-2D-870	870	1.9	460	1312	RED	6
Y2RSI-2D-1200N	1200	1.9	638	1818	RED/BLACK	4.3
Y2RSI-2D-1450	1450	1.8	900	2450	TAN	3.6
Y2RSI-2D-1690	1690	1.7	1140	2892	PINK	3.1
Y2RSI-2D-2000N	2000	1.7	1318	3342	PINK/BLACK	2.6
Y2RSI-2D-2640N	2640	1.5	1854	4283	PINK/GRAY	2
Y2RSI-2D-2870N	3080	1.5	2004	4629	PINK/GRAY/ ORANGE	1.7
Y2RSI-2D-3280N	3740	1.8	2134	4930	PINK/GRAY/DK BROWN	1.4

## 2" DEFLECTION ISOLATOR INSTALLATION AND ADJUSTMENT

1. Read instructions in their entirety before beginning installation.
2. Isolators are shipped fully assembled and are to be positioned in accordance with the submittal drawings or as otherwise recommended.
3. Set isolators on floor, housekeeping pad, or sub-base, ensuring that all isolator center lines match the equipment mounting holes. The VMC group recommends that the isolator base plates ("B") be installed on a level surface. Shim or grout as required, leveling all isolator base plates to the same elevation (1/4-inch maximum difference can be tolerated).
4. Bolt or anchor all isolators to supporting structure utilizing base plate thru holes ("C") or weld base plate to supporting structure with 3/8 fillet weld 2" long @ 4" on center around entire base plate or as engineered for specific load and or field conditions.
5. Isolators are shipped to the job site with (2) removable spacer shims ("E") between the top plate and the housing. These shims must be in place when the equipment is positioned over the isolators.
6. With all shims ("E") in place, position equipment on top of plate ("A") of isolator. Bolt equipment securely to top plate of isolator using a minimum of (2) 5/8 UNC A325 grade 5 SAE bolts or weld equipment or bracket to the top plate ("A") of isolator with a minimum of 3/8 fillet welds 2" long @ 3" on center for a minimum total weld of 10". (All sides of equipment or bracket resting on top plate ("A") must be welded).
7. The adjustment process can only begin after the equipment or machine is at its full operating weight.
8. Back off each of the (4) limit stop lock nuts ("F") on isolators 1/2".
9. Adjust each isolator in sequence by turning spring adjusting nuts ("G") one full clockwise turn at a time. Repeat this procedure on all isolators, one at a time. Check the limit stop lock nuts ("F") periodically to ensure that clearance between the washer and rubber grommet is maintained. Stop adjustment of isolator only when the top plate ("A") has risen just above the shim ("E").
10. Remove all spacer shims ("E").
11. Fine adjust isolators to level equipment.
12. Adjust all limit stop lock nuts ("F") per isolator, maintaining a 1/4 to 3/8-inch gap. The limit stop nuts must be kept at this gap to ensure uniform bolt loading during uplift (as the case when equipment is drained).
13. Installation is complete.

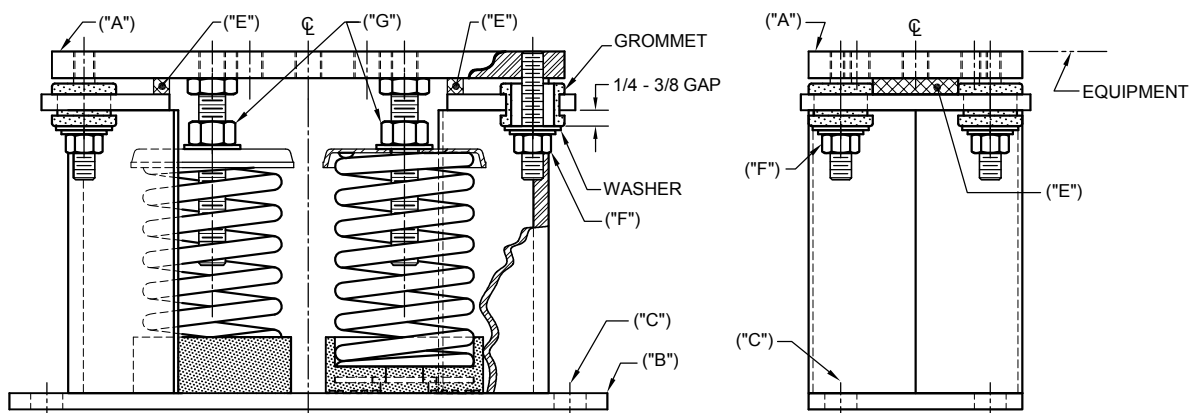

LD13763B

## NEOPRENE ISOLATOR CROSS-REFERENCE

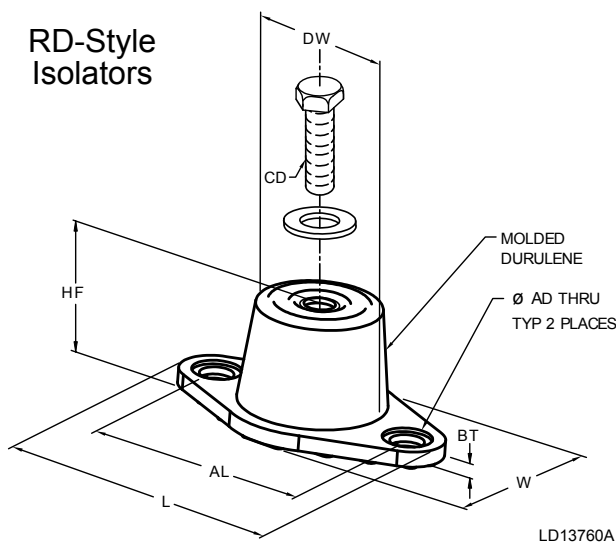

- All dimensions are inches, interpreted per ANSI Y14.
- See next page for installation instructions.
- Mount molded in weather resistant duralene compound as standard. Also available in other materials such as natural rubber, extreme high temperature silicone, high-damped silicone, nitrile and EDPM.
- AL = Mounting hole center to center spacing.
- HF = Free height of mount, prior to loading. Operating height calculated by the free height less the static deflection under load. All dimensions for reference only.
- Hardware zinc-electroplated.

MOUNT TYPE	DIMENSION DATA (INCHES)							
	L	W	HF	AL	AD	BT	CD	DW
RD1-WR	3.13	1.75	1.25	2.38	0.34	0.19	5/16-18 UNC X 3/4	1.25
RD2-WR	3.88	2.38	1.75	3.00	0.34	0.22	3/8-16 UNC X 1	1.75
RD3-WR	5.50	3.38	2.88	4.13	0.56	0.25	1/2-13 UNC X 1	2.50
RD4-WR	6.25	4.63	2.75	5.00	0.56	0.38	1/2-13 UNC X 1	3.00

MODEL NUMBER	RATED CAPACITY (LBS)	RATED DEFLECTION (IN)	DURO (± 5)
RD2-LIGHT BLUE-WR	35	0.4	30
RD2-BROWN-WR	45	0.4	40
RD2-BRICK RED-WR	70	0.4	50
RD 2-LIME-WR	120	0.4	60

MODEL NUMBER	RATED CAPACITY (LBS)	RATED DEFLECTION (IN)	DURO (± 5)
RD3-Brown-WR	250	0.5	40
RD3-Brick Red-WR	525	0.5	50
RD3-Lime-WR	750	0.5	60
RD3 Charcoal-WR	1100	0.5	70

MODEL NUMBER	RATED CAPACITY (LBS)	RATED DEFLECTION (IN)	DURO (± 5)
RD2-LIGHT BLUE-WR	135	0.5	30
RD2-BROWN-WR	170	0.5	40
RD2-BRICK RED-WR	240	0.5	50
RD 2-LIME-WR	380	0.5	60
RD2 CHARCOAL-WR	550	0.5	70

MODEL NUMBER	RATED CAPACITY (LBS)	RATED DEFLECTION (IN)	DURO (± 5)
RD4-BROWN-WR	1500	0.5	40
RD4-BRICK RED-WR	2250	0.5	50
RD4-LIME-WR	3000	0.5	60
RD4 CHARCOAL-WR	4000	0.5	70

## INSTALLATION OF NEOPRENE VIBRATION ISOLATORS

1. Read instructions in their entirety before beginning installation.
2. Isolators are shipped fully assembled and are to be positioned in accordance with the submittal drawings or as otherwise recommended.
3. Set isolators on floor, housekeeping pad, or sub-base, ensuring that all isolator centerlines match the equipment mounting holes. The VMC group recommends that the isolator base ("A") be installed on a level surface. Shim or grout as required, leveling all isolator bases to the same elevation (1/32-inch maximum difference can be tolerated).
4. Bolt or anchor all isolators to supporting structure utilizing base thru holes ("B").
5. Remove top bolt and top washer. Place equipment on top of isolators so that mounting holes in equipment or base line up with threaded hole ("C").
6. Reinstall top bolt and washer and tighten down.
7. Installation is complete.

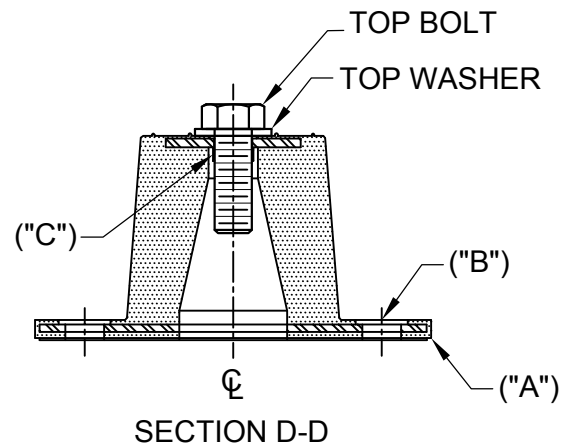
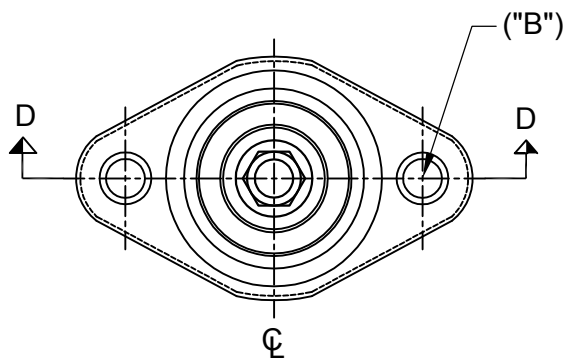

LD13762B

THIS PAGE INTENTIONALLY LEFT BLANK

## SECTION 6 – COMMISSIONING

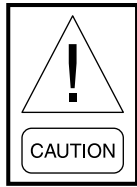

**Commissioning of this unit should only be carried out by Johnson Controls Authorized personnel.**

Commissioning personnel should be thoroughly familiar with the information contained in this literature, in addition to this section.

Perform the commissioning using the detailed checks outlined. See *Equipment Pre-Startup And Startup Checklist (Form 150.72-CL1)* as the commissioning procedure is carried out.

### PREPARATION – POWER OFF

The following basic checks should be made with the customer power to the unit switched OFF.

#### Inspection

Inspect unit for installation damage. If found, take action and/or repair as appropriate.

#### Refrigerant Charge

Packaged units are normally shipped as standard with a full refrigerant operating charge. Check that refrigerant pressure is present in both systems and that no leaks are apparent. If no pressure is present, a leak test must be undertaken, the leak(s) located and repaired. Remote systems and units are supplied with a nitrogen holding charge. These systems must be evacuated with a suitable vacuum pump/recovery unit as appropriate to below 500 microns.

Do not liquid charge with static water in the cooler. Care must also be taken to liquid charge slowly to avoid excessive thermal stress at the charging point. Once the vacuum is broken, charge into the condenser coils with the full operating charge as given in *SECTION 5 – TECHNICAL DATA*.

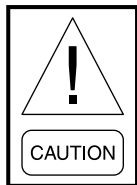

**ALWAYS keep the water pump running when vacuuming the system, removing refrigerant from the system or adding refrigerant to the system until the process is completed. If you do NOT, the evaporator may freeze and ruin the system.**

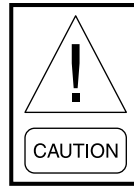

**Charging after vacuuming - NEVER add more than 5% of specified amount into the evaporator. This will lead to compressor failure when compressor starts. It may also shorten the life of the compressor if too much refrigerant stays inside the evaporator.**

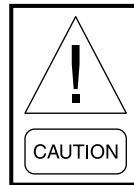

**Do NOT overcharge the system. Otherwise High Discharge Pressure will frequently occur.**

### Charging Refrigerant

If you vacuum the system first, add only the volume of refrigerant shown on the nameplate.

However, sometimes the system can run without enough refrigerant in it. If you have no idea how much refrigerant is inside of the system, then follow the steps below.

1. Connect the charging hose between the refrigerant tank and the angle valve at the inlet of evaporator. Exclude the air inside of hose.
2. Put the refrigerant tank on a scale and read the initial weight. Leave the tank on scale until process is complete.
3. Get as many compressors running as the system permits.
4. Open the angle valve 1.5 turns.
5. Open the valve on the tank.



**Quickly shut down the angle valve or the tank valve immediately if all of compressors stop suddenly in the process of charging.**

6. Monitor the suction superheat (SH) and liquid subcooling (SC). If SH is around 10R and SC > 6R, close the angle valve. Wait at least 15 min;
7. If SC < 10R or SH > 10R always, continue to charge the system. Open the angle valve 1.5 turns. Close it after one pound is added. Wait another 15min. Repeat this step until both SC and SH are around 10R with all of the fans and compressors running;
8. Close the angle valve and tank valve. Disconnect the hose.

## Service and Oil Line Valves

Open each compressor suction, economizer, and discharge service valve. If valves are of the back-seat type, open them fully (counterclockwise) then close one turn of the stem to ensure operating pressure is fed to pressure transducers. Open the liquid line service valve and oil return line ball valve fully in each system.

## Compressor Oil

To add oil to a circuit – connect a Johnson Controls hand oil pump (Part No. 470-10654-000) to the 1/4” oil charging connection on the compressors with a length of clean hose or copper line, but do not tighten the flare nut. Use YORK “V” oil 011-00949-000, when adding oil to Copeland compressor. The Bitzer compressor uses 011-00982-000 oil. Pump oil until all air has been purged from the hose then tighten the nut. Stroke the oil pump to add oil to the oil system. Approximately 1.8 to 2.3 gallons is present in the each refrigerant system. Oil levels in the oil equalizing line sight glass should be between the bottom and the middle of the sight glass with the system OFF. High oil levels may cause excessive oil carryover in the system. High oil concentration in the system may cause nuisance trips resulting from incorrect readings on the level sensor and temperature sensors. Temperature sensor errors may result in poor liquid control and resultant liquid overfeed and subsequent damage to the compressor. While running, a visible sign of oil splashing in the sight glass is normal.

## Fans

Check that all fans are free to rotate and are not damaged. Ensure blades are at the same height when rotated. Ensure fan guards are securely fixed.

## Isolation / Protection

Verify all sources of electrical supply to the unit are taken from a single point of isolation. Check that the maximum recommended fuse sizes given in *SECTION 5 – TECHNICAL DATA* has not been exceeded.

## Control Panel

Check the panel to see that it is free of foreign materials (wire, metal chips, etc.) and clean out if required.

## Power Connections

Check that the customer power cables are connected correctly to the terminal blocks or optional circuit breaker. Ensure that connections of power cables within the panels to the circuit breaker or terminal blocks are tight.

## Grounding

Verify that the unit’s protective ground terminal(s) are properly connected to a suitable grounding point. Ensure that all unit internal ground connections are tight.

## Supply Voltage

Verify that the site voltage supply corresponds to the unit requirement and is within the limits given in *SECTION 5 – TECHNICAL DATA*.

## Water System

Verify the chilled liquid system has been installed correctly, and has been commissioned with the correct direction of water flow through the cooler. The inlet should be at the refrigerant piping connection end of the cooler. Purge air from the top of the cooler using the plugged air vent mounted on the extension pipe.

Flow rates and pressure drops must be within the limits given in *SECTION 5 – TECHNICAL DATA*. Operation outside of these limits is undesirable and could cause damage.

If mains power must be switched OFF for extended maintenance or an extended shutdown period, the compressor suction, discharge and economizer service stop valves should be closed (clockwise). If there is a possibility of liquid freezing due to low ambient temperatures, the coolers should be drained or power should be applied to the chiller. This will allow the cooler heater to protect the cooler from freezing down to –20 °F. Before placing the unit back in service, valves should be opened and power must be switched ON (if power is removed for more than 8 hours) for at least 8 hours (24 hours if ambient temperature is below 86 °F [30 °C]) before the unit is restarted.

### Flow Switch

Verify a chilled water flow switch is correctly fitted in the customer's piping on the cooler outlet, and wired into the control panel correctly using shielded cable.

There should be a straight run of at least 5 pipe diameters on either side of the flow switch. The flow switch should be connected to terminals 13 and 14 of XTBC1 on the panel.

### Temperature Sensor(s)

Ensure the leaving liquid temperature sensor is coated with heat conductive compound (Part No. 013-00890-000) and is inserted to the bottom of the water outlet sensor well in the cooler. This sensor also provides some freeze protection and must always be fully inserted in the water outlet sensor well.

### PREPARATION – POWER ON



*Perform the commissioning using the detailed checks outlined. See Equipment Pre-Startup And Startup Checklist (Form 150.72-CL1) as the commissioning procedure is carried out.*

Apply power to the chiller. Turn on the option panel circuit breaker if supplied.



***The machine is now live!***

### Switch Settings

Assure the chiller OFF/ON UNIT switch at the bottom of the keypad is OFF. Place the optional circuit breaker handle on the panel door to ON. The customer's disconnection devices can now be set to ON.

Verify the control panel display is illuminated. Assure the system switches under the SYSTEM SWITCHES key are in the OFF position.

### Compressor Heaters

Verify the compressor heaters are energized. If the ambient temperature is above 96 °F (36 °C) the compressor heaters must be on for at least 8 hours before start-up to ensure all refrigerant liquid is driven out of the compressor and the oil. If the ambient temperature is below 86 °F (30 °C), allow 24 hours.

### HOW TO COMMISSION THE PUMP VFD

1. Put pump in HAND mode.



LD18418

2. Change parameter 0-20 (default value is option 1601 – “Reference [Unit]”) to option 1850 “Sensorless Readout” to display Sensorless flow readout on top left corner of screen.



LD18419

3. Change parameter 0-22 (default value is option 1610 – “Power [kW]”) to option 1654 “Feedback 1 [unit]” to display Sensorless pressure readout on top right corner of screen.
4. Check with customer regarding new actual flow and head and verify what flow is required. Ramp the pump up or down to achieve requested flow. Record the VFD sensorless flow and pressure – this will be your new setpoint.
5. Set parameter 20-21 to the Sensorless Pressure readout taken in the previous step.



LD18420

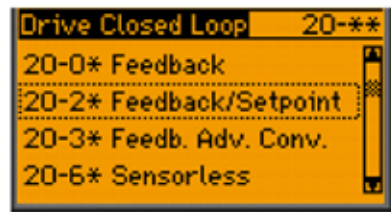

LD18421



LD18422

6. Set parameter 22-89 to the Sensorless Flow readout taken in the previous step.



LD18423

7. Set parameter 22-87 to a value that is X% of the value in 20-21. This percentage needs to be calculated based on the design flow and the published minimum flow for the unit. This ensures that the drive will not allow the pump to operate below the minimum flow of the chiller. You have now readjusted the quadratic control curve to match actual site conditions.
8. Change parameter 0-20 back to default value of option 1601 – “Reference [Unit]”.
9. Change parameter 0-22 back to default value of option 1610 – “Power [kW]”.
10. Put the VFD back into AUTO mode.



LD18424

Supersedes: 150.72-CL1 (817)

Form 150.72-CL1 (1217)



**MODEL - YLAA**

**STARTUP CHECKLIST**

CUSTOMER: \_\_\_\_\_ JOB NAME: \_\_\_\_\_  
 ADDRESS: \_\_\_\_\_ LOCATION: \_\_\_\_\_  
 PHONE: \_\_\_\_\_ CUSTOMER ORDER NO: \_\_\_\_\_  
 JCI TEL NO: \_\_\_\_\_ JCI ORDER NO: \_\_\_\_\_ JCI CONTRACT NO: \_\_\_\_\_

CHILLER MODEL NO: \_\_\_\_\_ UNIT SERIAL NO: \_\_\_\_\_  
 The work (as checked below) is in process and will be completed by: \_\_\_\_\_ / \_\_\_\_\_ / \_\_\_\_\_  
Month Day Year

The following work must be completed in accordance with installation instructions:

**A. PRE-STARTUP**

**Unit Checks (No Power)**

The following basic checks should be made with the customer power to the unit switched OFF.

1. Inspect the unit for shipping or installation damage .....
2. Assure that all piping has been completed. ....
3. Visually check for refrigerant piping leaks .....
4. If available, open suction line ball valve, discharge line ball valve, and liquid line valve for each system.....
5. At shutdown, the oil level should be between the bottom and middle of the oil equalizing sight glass. ....
6. Are water pumps ON?
  - a. Check and adjust water pump flow rate and pressure drop across the cooler Refer to *Operating Limitations, SECTION 8 - TECHNICAL DATA (Form 150.72-ICOM6)*. ....
  - b. Is the flow switch in place, wired properly, and operational?.....
  - c. Are the chilled water pumps operational? .....
  - d. Is the water system filled with water? .....
  - e. Is ALL air purged from the water system? .....
7. Is the control panel free of foreign material (wires, metal chips and so on)? .....

**NOTE:** Any air found in the water system MUST be purged before the chiller can start up. Excessive flow may cause catastrophic damage to the heat exchanger (evaporator)

8. Is ALL power wired to the chiller and meets N.E.C. and local codes?
  - a. High voltage.....
  - b. Low voltage .....
  - c. Check tightness of power wiring inside the power panel on both sides of the motor contactors and overloads. ....
  - d. Check to ensure BAS control is wired correctly and operational.....
9. Check for proper size fuses in main and control circuits, and verify overload setting corresponds with RLA and FLA values in electrical tables (see Table 8 and Table) .....
10. Assure 120VAC (110VAC for 50Hz units) Control Power to TB1 has 15 amp minimum capacity. ....
11. Are all water temp sensors inserted completely into their respective wells and are coated with heat conductive compound? .....
12. Are the evaporator TXV bulbs strapped onto the suction lines at 4 or 8 o'clock positions or suction temp. sensors if EEVs are installed? .....
13. Do all sides of the unit have the recommended amount of space for air ventilation? Refer to *SECTION 4 - INSTALLATION (Form 150.72-ICOM6)*. ...
14. Does the cabinet edge clear the insulation of cable at the power entry to avoid slicing the cable? .....

**B. COMPRESSOR HEATER  
(Power On - 24 Hours Prior To Start)**

Apply 120VAC and verify its value between terminals 5 and 2 of XTBC2. The voltage should be 120VAC (110VAC for 50Hz units) plus or minus 10%.....

**NOTE:** Power must be applied 24 hours prior to start-up. Each heater should draw approximately 0.5 to 1A.

**6**

SETPOINTS ENTRY LIST

OPTIONS	
Display Language	
Sys 1 Switch	
Sys 2 Switch	
Chilled Liquid	
Ambient Control*	
Local/Remote Mode	
Control Mode	
Display Units	
Lead/Lag Control*	
Fan Control*	
Manual Override	
Current Feedback	
Power Fail Restart	
Soft Start**	
Unit Type**	
Refrigerant Type**	
Flash Card Update	
Remote Temperature Reset	
External Evaporator Pump	
YORK Hydro Kit Pump	
Pump Selection	
Data Log to Flashcard	
Expansion Valve Type**	
COOLING SETPOINTS	
Cooling Setpoint	
Range	
EMS-PWM Max. Setpoint	
PROGRAM	
Discharge Pressure Cutout	
Suction Pressure Cutout	
Low Ambient Temp. Cutout	
Leaving Liquid Temp. Cutout	
Anti-Recycle Time	
Fan Control ON Pressure	
Fan Differential OFF Pressure	
Total # of Compressors	
Number of Fans/System*	
Unit/Sys Voltage*	
Remote Unit ID	

\*Not on All Models    \*\*Viewable Only

C. STARTUP

Panel checks (Power On - Both unit switch Off)

1. Apply 3-phase power and verify its value. Voltage imbalance should be no more than 2% of the average voltage. ....
2. Apply 120VAC (110VAC for 50Hz units) and verify its value on the terminal block in the Power Panel. Make the measurement between Terminals 5 and 2 of XTBC2. The voltage should be 120VAC plus or minus 10% .....
3. Program/verify the Cooling Setpoints, Program Setpoints, and Unit Options. Record the values in the Setpoints Entry List table. ....
4. Place the unit into Service Mode and cycle each condenser fan to ensure proper rotation. ....
5. Turn system 2 OFF and leave System 1 running. Refer to SECTION 6 – OPERATIONS (Form 150.72-ICOM6), UNIT KEYS, Option 2 for more information on System Switches. ....
6. Connect a manifold gauge to system 1 suction and discharge service valves. ....
7. Place the Unit Switch in the control panel to the ON position. ....

**NOTE:** The chilled liquid setpoint may need to be temporarily lowered to ensure all compressors cycle ON.

As each compressor cycles ON, ensure that the discharge pressure rises and the suction pressure decreases. If this does not occur, the compressor being tested is operating in the reverse direction and must be corrected.

8. Verify proper compressor rotation and then turn the Unit Switch to "OFF." ....
9. Turn system 1 OFF and system 2 ON (two system units only). Refer to SECTION 6 – OPERATIONS (Form 150.72-ICOM6), UNIT KEYS for more information. ....

**NOTE:** This unit uses scroll compressors which can only operate in one direction. Failure to observe this will lead to compressor failure.

10. Place the Unit Switch in the control panel to the ON position. ....

**NOTE:** The chilled liquid setpoint may need to be temporarily lowered to ensure all compressors cycle ON.

As each compressor cycles ON, ensure that the discharge pressure rises and the suction pressure decreases. If this does not occur, the compressor being tested is operating in the reverse direction and must be corrected.

11. Verify proper compressor rotation and then turn the Unit Switch to OFF. ....

**D. CHECKING SUPERHEAT AND SUBCOOLING**

The subcooling temperature of each system can be calculated by recording the temperature of the liquid line at the outlet of the condenser and subtracting it from the liquid line saturation temperature at the liquid stop valve (liquid line saturation temperature is converted from a temperature/pressure chart).

**Example:**

Liquid line pressure =  
 325 PSIG converted to temp. 101 °F  
 minus liquid line temp. - 83 °F  
 Subcooling = 18 °F

The subcooling should be adjusted to 18 °F (-8 °C) at design conditions.

Record the liquid line pressure and its saturated temperature, liquid line temperature and subcooling below:

	SYS 1	SYS 2	
Liq Line Press =	_____	_____	PSIG
Saturated Temp =	_____	_____	°F
Liq Line Temp =	_____	_____	°F
Subcooling =	_____	_____	°F

After the subcooling is verified, the suction superheat should be checked. The superheat should be checked only after steady state operation of the chiller has been established, the leaving water temperature has been pulled down to the required leaving water temperature, and the unit is running in a fully loaded condition. Correct superheat setting for a system is 10 °F to 15 °F (5.56 °C to 8.33 °C) 18" (46 cm) from the heat exchanger.

**Superheat should typically be set for no less than 10 °F with only a single compressor running on a circuit.**

The superheat is calculated as the difference between the actual temperature of the returned refrigerant gas in the suction line entering the compressor and the temperature corresponding to the suction pressure as shown in a standard pressure/temperature chart.

**Example:**

Suction Temp = 46 °F  
 minus Suction Press  
 105 PSIG converted to Temp - 34 °F  
 Superheat = 12 °F

When adjusting the expansion valve (TXV only), the adjusting screw should be turned not more than one turn at a time, allowing sufficient time (approximately 15 minutes) between adjustments for the system and the thermal expansion valve to respond and stabilize.

Assure that superheat is set at a minimum of 10 °F (5.56 °C) with a single compressor running on each circuit.

12. Record the suction temperature, suction pressure, saturation temperature, and superheat of each system below:

	SYS 1	SYS 2	
Suction Temp =	_____	_____	°F
Suction Pressure =	_____	_____	PSIG
Saturation Temp =	_____	_____	°F
Superheat =	_____	_____	°F

**E. LEAK CHECKING**

Leak check compressors, fittings, and piping to ensure no leaks.

If the unit is functioning satisfactorily during the initial operating period with no safeties trip and the compressors cycle to control water temperature to the setpoint, the chiller is considered ready to be placed into operation.

THIS PAGE INTENTIONALLY LEFT BLANK

## SECTION 7 – UNIT CONTROLS

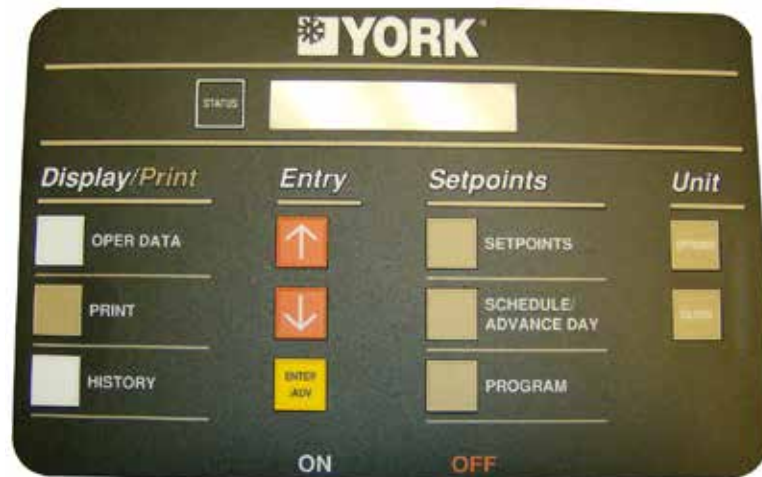

LD13283

### INTRODUCTION

The YORK Control Center is a microprocessor based control system designed to provide the entire control for the liquid chiller. The control logic embedded in the microprocessor based control system will provide control for the chilled liquid temperatures, as well as sequencing, system safeties, displaying status, and daily schedules. The MicroComputer Control Center consists of four basic components:

1. IPU II and I/O Boards
2. Transformer
3. Display
4. Keypad

The keypad allows programming and accessing setpoints, pressures, temperatures, cutouts, daily schedule, options, and fault information.

Remote cycling, demand limiting and chilled liquid temperature reset can be accomplished by field supplied contacts.

Compressor starting/stopping and loading/unloading decisions are performed by the Microprocessor to maintain leaving or return chilled liquid temperature. These decisions are a function of temperature deviation from setpoint.

A Master ON/OFF switch activates or deactivates the unit.

### IPU II AND I/O BOARDS

The IPU and I/O boards are assembled to function as a single microprocessor controller. The IPU II board contains a microprocessor and is the controller. The I/O board handles all of the chiller I/O (Inputs and Outputs). System inputs from pressure transducers and temperature sensors are connected to the I/O board.

The I/O board constantly scans inputs to monitor the chiller operating conditions. The input values are transmitted the IPU II microprocessor board. From this information, the IPU II then issues commands to the I/O board relay outputs to control contactors, solenoids, etc. for Chilled Liquid Temperature Control and to react to safety conditions. The I/O board converts logic signals to operate relay outputs to 115VAC levels used by motor contactors, fan contactors, solenoid valves, etc. to control system operation. The low voltage side of all relay coils on the I/O board are powered by +12V.

Keypad commands are actuated upon by the microprocessor to change setpoints, cutouts, scheduling, operating requirements, and to provide displays. The keypad and display are connected to the I/O board.

The on-board power supply converts 24VAC from 75VA, 120/24VAC 50/60Hz UL listed class 2 power transformer to +12V, +5V and +3.3V using switching and linear voltage regulators located on the I/O and IPU II boards. These voltages are used to operate integrated circuitry on the board. The 40 character display and unit sensors (transducers and temp sensors) are sup-

plied power for the micro board +5V supply. 24VAC is rectified, but not regulated, to provide unregulated +30VDC to supply all of the digital inputs.

The I/O board contains one green “Power” LED to indicate that the board is powered up and one red “Status” LED to indicate by blinking that the processor is operating. The I/O board also contains two sets of Receiver/Transmit LED’s, one for each available serial communication port. The receive LED’s are green, and the Transmit LED’s are red.

A jumper on the I/O board selects 4 to 20mA or 0 to 10VDC as the input type on the remote temperature reset analog input.

### **TRANSFORMER**

A 75VA, 120/240VAC, 50/60Hz transformer is provided to supply power to the Microprocessor Board, which in turn rectifies, filters, and regulates as necessary to supply power to the display, sensors, and transducers.

### **DISPLAY**

The 40 Character Display (2 lines of 20 characters) is a liquid crystal display used for displaying system parameters and operator messages.

When a key is pressed, such as the OPER DATA key, system parameters will be displayed and will remain on the display until another key is pressed. The system parameters can be scrolled with the use of the ↑ (UP) and ↓ (DOWN) arrow keys. The display will update all information at a rate of about 1 a second.

Display Messages may show characters indicating “greater than” (>) or “less than” (<). These characters indicate the actual values are greater than or less than the limit values which are being displayed.

### **KEYPAD**

The 12 button non-tactile keypad allows the user to retrieve vitals system parameters such as system pressures, temperatures, compressor running times and starts, option information on the chiller, and system setpoints. This data is useful for monitoring chiller operation, diagnosing potential problems, troubleshooting, and commissioning the chiller.

It is essential the user become familiar with the use of the keypad and display. This will allow the user to make full use of the capabilities and diagnostic features available.

### **UNIT SWITCH**

A unit ON/OFF switch is just underneath the keypad. This switch allows the operator to turn the entire unit OFF if desired. The switch must be placed in the ON position for the chiller to operate.

### **BATTERY BACK-UP**

The IPU II contains a Real Time Clock integrated circuit chip with an internal battery backup. The purpose of this battery backup is to assure any programmed values (setpoints, clock, cutouts, etc.) are not lost during a power failure regardless of the time involved in a power cut or shutdown period.

### **PROGRAMMING # OOF COMPRESSORS**

The total number of compressors is programmable under the PROGRAM key. Dual (2) system chillers can have 4, 5, or 6 compressors.

## STATUS KEY



00066VIP

### Unit Status

Pressing the STATUS key will enable the operator to determine current chiller operating status. The messages displayed will include running status, cooling demand, fault status, external cycling device status. The display will be a single message relating to the highest priority message as determined by the microprocessor. Status messages fall into the categories of General Status and Fault Status.

The following General, Safety, and Warning messages are displayed when the STATUS key is pressed. Following each displayed message is an explanation pertaining to that particular message.

### General Status Messages

In the case of messages which apply to individual systems, SYS 1 and SYS 2 messages will both be displayed and may be different. In the case of single system units, all SYS 2 messages will be blank.

**UNIT SWITCH OFF  
SHUTDOWN**

This message informs the operator that the UNIT switch on the control panel is in the OFF position which will not allow the unit to run.

**REMOTE CONTROLLED  
SHUTDOWN**

The REMOTE CONTROLLED SHUTDOWN message indicates that either an ISN system or RCC has turned the unit OFF, not allowing it to run.

**DAILY SCHEDULE  
SHUTDOWN**

The DAILY SCHEDULE SHUTDOWN message indicates that the daily/holiday schedule programmed is keeping the unit from running.

**REMOTE STOP  
NO RUN PERM**

REMOTE STOP NO RUN PERM shows that a remote start/stop contact is open in series with the flow switch. These contacts are connected to Terminals 51 and 13 of XTBC1. A 3-second delay is built into the software to prevent nuisance shutdowns due to erroneous signals on the run permissive input.

**FLOW SWITCH  
OPEN**

FLOW SWITCH OPEN indicates the flow switch contacts connected to Terminals 13 and 14 of XTBC1 are open. A 3-second delay is built into software to prevent nuisance shutdowns due to erroneous signals from the flow switch.

**SYS 1 SYS SWITCH OFF  
SYS 2 SYS SWITCH OFF**

SYS SWITCH OFF tells that the system switch under OPTIONS is turned OFF. The system will not be allowed to run until the switch is turned back ON.

7

```

SYS 1 NO COOL LOAD
SYS 2 NO COOL LOAD

```

This message informs the operator that the chilled liquid temperature is below the point (determined by the setpoint and control range) that the microprocessor will bring on a system or that the microprocessor has not loaded the lead system far enough into the loading sequence to be ready to bring the lag system ON. The lag system will display this message until the loading sequence is ready for the lag system to start.

```

SYS 1 COMPS RUN X
SYS 2 COMPS RUN X

```

The COMPS RUNNING message indicates that the respective system is running due to demand. The “X” will be replaced with the number of compressors in that system that are running.

```

SYS 1 AR TIMER XX S
SYS 2 AR TIMER XX S

```

The anti-recycle timer message shows the amount of time left on the respective systems anti-recycle timer. This message is displayed when the system is unable to start due the anti-recycle timer being active.

```

SYS 1 AC TIMER XX S
SYS 2 AC TIMER XX S

```

The anti-coincidence timer is a software feature that guards against 2 systems starting simultaneously. This assures instantaneous starting current does not become excessively high due to simultaneous starts. The microprocessor limits the time between compressor starts to 1 minute regardless of demand or the anti-recycle timer being timed out. The anti-coincidence timer is only present on two system units.

```

SYS 1 DSCH LIMITING
SYS 2 DSCH LIMITING

```

When this message appears, discharge pressure limiting is in effect. The Discharge Pressure Limiting feature is integral to the standard software control; however the discharge transducer is optional on some models. Therefore, it is important to keep in mind that this control will not function unless the discharge transducer is installed in the system.

The limiting pressure is a factory set limit to keep the system from faulting on the high discharge pressure cutout due to high load or pull down conditions. When the unload point is reached, the microprocessor will automatically unload the affected system by de-energizing one compressor. The discharge pressure unload will occur when the discharge pressure gets within 10 PSIG (0.69 barg) of the programmed discharge pressure cutout. This will only happen if the system is fully loaded and will shut only one compressor OFF. If the system is not fully loaded, discharge limiting will not go into effect. Reloading the affected system will occur when the discharge pressure drops to 85% of the unload pressure and 10 minutes have elapsed.

```

SYS 1 SUCT LIMITING
SYS 2 SUCT LIMITING

```

When this message appears, suction pressure limiting is in effect. The suction pressure limit is a control point that limits the loading of a system when the suction pressure drops to within 15% above the suction pressure cutout. On a standard system programmed for 44 PSIG/3.0 Bar suction pressure cutout, the microprocessor would inhibit loading of the affected system with the suction pressure less than or equal to  $1.15 * 44 \text{ PSIG/3.0 Bar} = 50 \text{ PSIG/3.5 Bar}$ . The system will be allowed to load after 60 seconds and after the suction pressure rises above the suction pressure load limit point.

```

SYS 1 LOAD LIMIT XX %
SYS 2 LOAD LIMIT XX %

```

This message indicates that load limiting is in effect and the percentage of the limiting in effect. This limiting could be due to the load limit/pwm input, ISN or RCC controller sending a load limit command.

```

MANUAL
OVERRIDE

```

If MANUAL OVERRIDE mode is selected, the STATUS display will display this message. This will indicate that the Daily Schedule is being ignored and the chiller will start-up when chilled liquid temperature allows, Remote Contacts, UNIT switch and SYSTEM switches permitting. This is a priority message and cannot be overridden by anti-recycle messages, fault messages, etc. when in the STATUS display mode. Therefore, do not expect to see any other STATUS messages when in the MANUAL OVERRIDE mode. MANUAL

OVERRIDE is to only be used in emergencies or for servicing. Manual override mode automatically disables itself after 30 minutes.

```
SYS 1 PUMPING DOWN
SYS 2 PUMPING DOWN
```

The PUMPING DOWN message indicates that a compressor in the respective system is presently in the process of pumping the system down. When pumpdown is initiated on shutdown, the liquid line solenoid or EEV will close and a compressor will continue to run. When the suction pressure decreases to the suction pressure cutout setpoint or runs for 180 seconds, whichever comes first, the compressor will cycle OFF.

### Fault Safety Status Messages

Safety Status messages appear when safety thresholds in the unit have been exceeded. Safeties are divided into two categories – system safeties and unit safeties. System safeties are faults that cause the individual system to be shut down. Unit safeties are faults that cause all running compressors to be shut down. Following are display messages and explanations.

#### System Safeties

System safeties are faults that cause individual systems to be shut down if a safety threshold is exceeded for 3 seconds. They are auto reset faults in that the system will be allowed to restart automatically after the fault condition is no longer present. However, if 3 faults on the same system occur within 90 minutes, that system will be locked out on the last fault. This condition is then a manual reset. The system switch (under OPTIONS key) must be turned OFF and then back on to clear the lockout fault. Fault messages will be displayed whenever a system is locked out.

```
SYS 1 HIGH DSCH PRES
SYS 2 HIGH DSCH PRES
```

The Discharge Pressure Cutout is a software cutout in the microprocessor and is backed-up by a mechanical high pressure cutout switch located in the refrigerant circuit. It assures that the system pressure does not exceed safe working limits. The system will shutdown when the programmable cutout is exceeded and will be allowed to restart when the discharge pressure falls 40 PSIG below the cutout. Discharge transducers must be installed for this function to operate.

```
SYS 1 LOW SUCT PRESS
SYS 2 LOW SUCT PRESS
```

The Suction Pressure Cutout is a software cutout that helps protect the chiller from an evaporator freeze-up should the system attempt to run with a low refrigerant charge or a restriction in the refrigerant circuit.

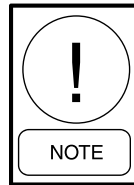

*Repeated starts after resetting a low suction pressure fault will cause evaporator freeze-up. Whenever a system locks out on this safety or any safety, immediate steps should be taken to identify the cause.*

At system start, the cutout is set to 10% of programmed value. During the next 3 minutes the cutout point is ramped up to the programmed cutout point. If at any time during this 3 minutes the suction pressure falls below the ramped cutout point, the system will stop. This cutout is completely ignored for the first 30 seconds of system run time to avoid nuisance shutdowns, especially on units that utilize a low pressure switch in place of the suction pressure transducer.

After the first 3 minutes, if the suction pressure falls below the programmed cutout setting, a “transient protection routine” is activated. This sets the cutout at 10% of the programmed value and ramps up the cutout over the next 30 seconds. If at any time during this 30 seconds the suction pressure falls below the ramped cutout, the system will stop.

```
SYS 1 MP / HPCO FAULT
SYS 2 MP / HPCO FAULT
```

```
SYS 1 MP / HPCO INHIB
SYS 2 MP / HPCO INHIB
```

The Motor Protector/Mechanical High Pressure Cutout protect the compressor motor from overheating or the system from experiencing dangerously high discharge pressure.

This fault condition is present when CR1 (SYS 1) or CR2 (SYS 2) relays de-energize due to the HP switch or motor protector opening. This causes the respective CR contacts to open causing 0VDC to be read on the inputs to the microboard. The fault condition is cleared when a 30VDC signal is restored to the input.

The internal motor protector opens at 185 °F to 248 °F (85 °C to 120 °C) and auto resets. The mechanical HP switch opens at 585 PSIG plus or minus 10 PSIG (27.92 barg plus or minus .69 barg) and closes at 330 PSIG plus or minus 25 PSIG (22.75 barg plus or minus 1.72 barg).

The compressor is also equipped with a discharge temperature sensor for the purpose of sensing internal scroll temperature. This sensor protects the scrolls from overheating due to inadequate cooling that may occur when refrigerant charge is low, or superheat is too high.

When the sensor senses a high temperature, it opens the motor protector circuit in the compressor causing the compressor to shut down.

During the first two faults an MP/HP INHIBIT message will be displayed and the system will not be locked out. Only after the third fault in 90 minutes will the MP/HPCO FAULT message be displayed.

Whenever the motor protector or discharge sensor shuts down a compressor and the system, the internal compressor contacts will open for a period of 30 minutes to assure that the motor or scroll temperatures have time to dissipate the heat and cool down. The MP/HP INHIBIT message will be displayed while these contacts are open or when the HPCO is open. While this message is displayed, the compressors will not be permitted to start.

After 30 minutes, the contacts will close and the system will be permitted to restart. The microprocessor will not try to restart the compressors in a system that shuts down on this safety for a period of 30 minutes to allow the internal compressor to time out.

During the 30 minute timeout, the MP/HPCO INHIB message will be displayed. The MP/HPCO fault will only be displayed after 3 shutdowns in 90 minutes, indicating the system is locked out and will not restart.

**SYS 1 HIGH MTR CURR**  
**SYS 2 HIGH MTR CURR**

When the System Current Feedback option is installed and selected (Option 11 under OPTIONS key Current Feedback), this safety will operate as follows. If the actual feedback voltage of the system proportional to currents exceeds the programmed trip voltage for 5 seconds, the system will shutdown.

This safety will shut down a system if either suction temperature or suction pressure sensors read out of range high or low. This condition must be present for 3 seconds to cause a system shutdown. The safety locks out a system after the first fault and will not allow automatic restarting.

### Unit Safeties

Unit safeties are faults that cause all running compressors to be shut down. Unit faults are auto reset faults in that the unit will be allowed to restart automatically after the fault condition is no longer present.

**UNIT FAULT :**  
**LOW AMBIENT TEMP**

The Low Ambient Temp Cutout is a safety shutdown designed to protect the chiller from operating in a low ambient condition. If the outdoor ambient temperature falls below the programmable cutout, the chiller will shut down. Restart can occur when temperature rises 2 °F above the cutoff.

**UNIT FAULT :**  
**LOW LIQUID TEMP**

The Low Leaving Chilled Liquid Temp Cutout protects the chiller from an evaporator freeze-up should the chilled liquid temperature drop below the freeze point. This situation could occur under low flow conditions or if the micro panel setpoint values are improperly programmed. Anytime the leaving chilled liquid temperature (water or glycol) drops below the cutout point, the chiller will shutdown. Restart can occur when chilled liquid temperature rises 2 °F above the cutout.

**UNIT FAULT :**  
**115VAC UNDER VOLTAGE**

The Under Voltage Safety assures that the system is not operated at voltages where malfunction of the microprocessor could result in system damage. When the 115VAC to the micro panel drops below a certain level, a unit fault is initiated to safely shut down the unit. Restart is allowed after the unit is fully powered again and the anti-recycle timers have finished counting down.

**UNIT FAULT :  
HIGH MTR CURR**

When the CURRENT FEEDBACK ONE PER UNIT option is selected under the OPTIONS key, the unit will shut down when the voltage exceeds the programmed trip voltage for 5 seconds.

The trip voltage is programmed at the factory according to compressor or unit RLA.

Restart will occur after the anti-recycle timer times out.

**Unit Warning**

The following messages are not unit safeties and will not be logged to the history buffer. They are unit warnings and will not auto-restart. Operator intervention is required to allow a restart of the chiller.

**!! LOW BATTERY !!  
CHECK PROG / SETP / OPTN**

The Low Battery Warning can only occur at unit power-up. On micro panel power-up, the RTC battery is checked. If a low battery is found, all programmed

setpoints, program values, options, time, schedule, and history buffers will be lost. These values will all be reset to their default values which may not be the desired operating values. Once a faulty battery is detected, the unit will be prevented from running until the PROGRAM key is pressed. Once PROGRAM is pressed the anti-recycle timers will be set to the programmed anti-recycle time to allow the operator time to check setpoints, and if necessary, reprogram programmable values and options.

If a low battery is detected, it should be replaced as soon as possible. The programmed values will all be lost and the unit will be prevented from running on the next power interruption. The RTC/battery (031-02565-000) is located at U5 on the microboard.

**INCORRECT  
UNIT TYPE**

This indicates the condensing unit jumper is installed between J11-12 and J11-7. This jumper must be removed to operate the chiller.

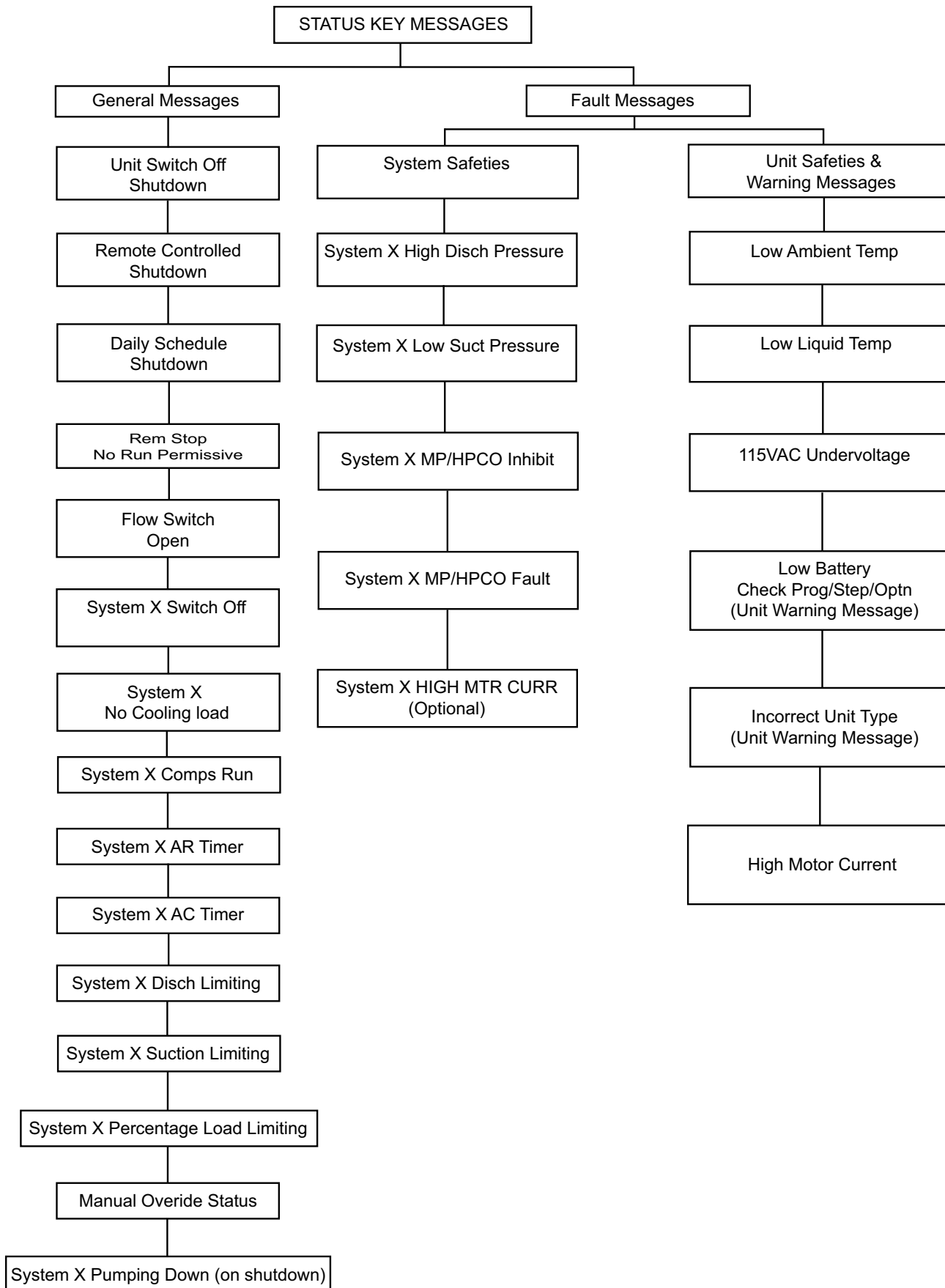

LD11297B

**FIGURE 33 - STATUS KEY MESSAGES QUICK REFERENCE LIST**

## DISPLAY/PRINT KEYS

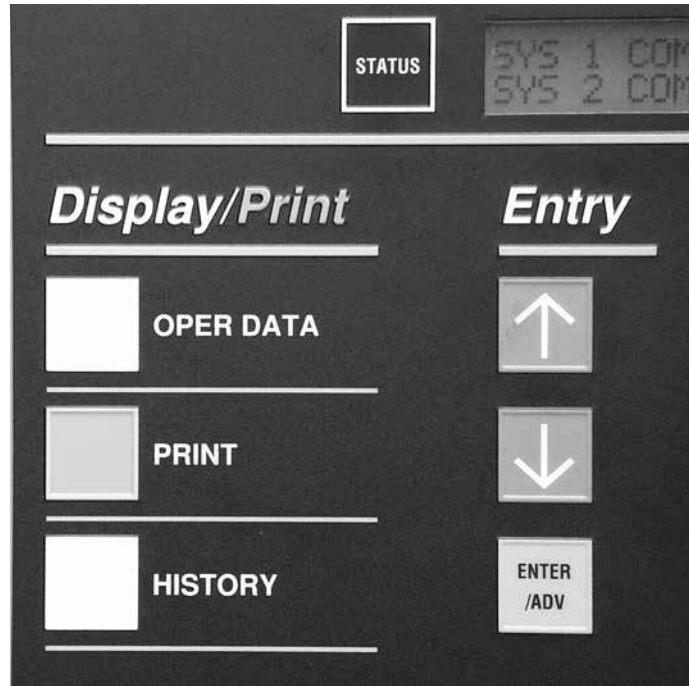

00067VIP

The Display/Print keys allow the user to retrieve system and unit information that is useful for monitoring chiller operation, diagnosing potential problems, troubleshooting, and commissioning the chiller.

System and unit information, unit options, setpoints, and scheduling can also be printed out with the use of a printer. Both real-time and history information are available.

### Oper Data Key

The OPER DATA key gives the user access to unit and system operating parameters. When the OPER DATA key is pressed, system parameters will be displayed and remain on the display until another key is pressed. After pressing the OPER DATA key, the various operating data screens can be scrolled through by using the ↑ (UP) and ↓ (DOWN) arrow keys or the ENTER/ADV key located under the “ENTRY” section.

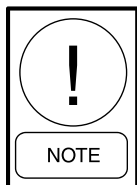

*System 2 information will only be displayed for 2 system units.*

With the “UNIT TYPE” set as a liquid chiller (no jumper from J11-7 to J11-12 on the I/O Board), the following list of operating data screens are viewable under the OPER DATA key in the order that they are displayed. The ↓ (DOWN) arrow key scrolls through the displays in the order they appear below:

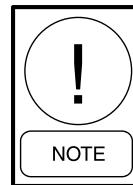

*The chiller MUST be set to be a liquid chiller (no jumper from J11-7 to J11-12 on the I/O Board). DO NOT operate the chiller if not properly set up.*

LCHLT = 46.2 °F  
 RCHLT = 57.4 °F

This display shows chilled leaving and return liquid temperatures. The minimum limit on the display for these parameters are 2.2 °F (-19 °C). The maximum limit on the display is 140 °F (60 °C).

AMBIENT AIR TEMP  
 = 87.5 °F

This display shows the ambient air temperature. The minimum limit on the display is 0.4 °F (-17.6 °C). The maximum limit on the display is 131.2 °F (55.1 °C).

```
S Y S X S P = 7 2 . 1 P S I G
      D P = 2 2 7 . 0 P S I G
```

These displays show suction and discharge pressures for each system. The discharge pressure transducer is optional on some models.

If the optional discharge transducer is not installed, the discharge pressure would display 0 PSIG (0 barg).

The minimum limits for the display are:

- Suction Pressure: 0 PSIG (0 barg)
- Discharge Pressure: 0 PSIG (0 barg)

The maximum limits for the display are:

- Suction Pressure: 400 PSIG (27.58 barg)
- Discharge Pressure: 650 PSIG (44.82 barg)

```
S Y S X H O U R S 1 = X X X X X
      2 = X X X X X, 3 = X X X X X
```

```
S Y S X S T A R T S 1 = X X X X X
      2 = X X X X X, 3 = X X X X X
```

The above two messages will appear sequentially for each system. The first display shows accumulated running hours of each compressor for the specific system. The second message shows the number of starts for each compressor on each system.

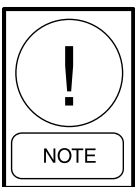

***Run times and starts will only be displayed for the actual number of systems and compressors on the unit.***

A total of 99,999 hours and starts can be logged before the counter rolls over to “0”.

```
LOAD TIMER 5 8 SEC
UNLOAD TIMER 0 SEC
```

This display of the load and unload timers indicate the time in seconds until the unit can load or unload. Whether the systems loads or unloads is determined by how far the actual liquid temperature is from setpoint. A detailed description of unit loading and unloading is covered under the topic of Capacity Control.

```
COOLING DEMAND
2 OF 8 STEPS
```

The display of COOLING DEMAND indicates the current “step” in the capacity control scheme when in Return Water Control Mode. The number of available steps are determined by how many compressors are in the unit. In the above display, the “2” does not mean that two compressor are running but only indicates that the capacity control scheme is on step 2 of 8. Capacity Control is covered in more detail in this publication which provides specific information on compressor staging (for Return Water Control only).

```
TEMP ERROR XXX . X ° F
TEMP RATE XXX . X ° F / M
```

The COOLING DEMAND message will be replaced with this message when Leaving Chilled liquid control is selected. This message indicates the temperature error and the rate of change of the chilled liquid temperature.

```
LEAD SYSTEM IS
SYSTEM NUMBER 2
```

This display indicates the current LEAD system. In this example system 2 is the LEAD system, making system 1 the LAG system. The LEAD system can be manually selected or automatic. See the programming under the *Options Key on page 131*. The Lead System display will only appear on a two system unit.

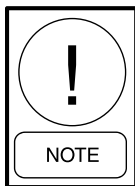

***A unit utilizing hot gas bypass should be programmed for MANUAL with system 1 as the lead system. Failure to do so will prevent hot gas operation if system 2 switches to the lead system when programmed for AUTOMATIC LEAD/LAG.***

```
EVAPORATOR HEATER
STATUS IS = XXX
```

This display indicates the status of the evaporator heater. The evaporator heater is controlled by ambient air temperature. When the ambient temperature drops below 40 °F the heater is turned ON. When the temperature rises above 45 °F the heater is turned OFF. An under voltage condition will keep the heater OFF until full voltage is restored to the system.

```

E V A P O R A T O R   W A T E R
P U M P           S T A T U S       = X X X X
    
```

The evaporator pump dry contacts are energized when any compressor is running, or the unit is not OFF on the daily schedule and the unit switch is ON, or the unit has shutdown on a Low Leaving Chilled Liquid fault. However, even if one of above is true, the pump will not run if the micro panel has been powered up for less than 30 seconds or if the pump has run in the last 30 seconds to prevent pump motor overheating.

```

E V A P   P U M P   T O T A L   R U N
H O U R S                               = X X X X X
    
```

The Evaporator Pump Total Run Hours display indicates the total pump run hours. Total hours continually increments similar to Compressor Run Hours. If dual pumps are fitted, run hours indicates total hours on both pumps.

```

A C T I V E   R E M O T E   C T R L
N O N E
    
```

There are several types of remote systems that can be used to control or monitor the unit. The following messages indicate the type of remote control mode active:

NONE – no remote control active. Remote monitoring may be via ISN.

ISN – YORK Talk via ISN allows remote load limiting and temperature reset through an ISN system.

LOAD LIM – Load limiting enabled using contact closure.

PWM TEMP – EMS temperature reset

*\*See Remote BAS/EMS Temperature Reset Using a Voltage or Current Signal on page 159.*

If the microprocessor is programmed for CURRENT FEEDBACK ONE PER UNIT under the OPTIONS key, the display will show up as the first display prior to the SYS 1 displays. Total chiller current is displayed as shown below:

```

U N I T       A M P S   =   5 4 . 0
V O L T S     =   1 . 2
    
```

If the microprocessor is programmed for CURRENT FEEDBACK NONE, no current display will appear.

```

S Y S   X   C O M P   S T A T U S
1 = X X X   2 = X X X   3 = X X X
    
```

```

S Y S   X   R U N   T I M E
X X - X X - X X - X X   D - H - M - S
    
```

```

S Y S   X   L L S V   I S   O N
H O T   G A S   S O L   I S   O F F
    
```

```

S Y S   X   F A N   S T A G E   3
    
```

```

S Y S   X   A M P S   =   3 6 . 0
V O L T S   =   0 . 8
    
```

The preceding five messages will appear sequentially, first for system 1, then for system 2.

The first message indicates the system and the associated compressors which are running.

The second message indicates the system run time in days – hours – minutes – seconds. Please note that this is not accumulated run time but pertains only to the current system cycle.

The third message indicates the system, and whether the liquid line solenoid or EEV pilot solenoid and hot gas solenoid are being turned ON by the microboard. Please note that hot gas is not available for system 2, so there is no message pertaining to the hot gas solenoid when system 2 message is displayed.

The fourth message indicates the stage of condenser fan operation that is active.

See *Standard Condenser Fan Control on page 154* for more information.

The fifth message displays current as sensed by the optional current feedback circuitry. The display reads out in amps along with the DC feedback voltage from the module. Current is calculated by:

$$\frac{225A \times \text{Actual Volts}}{5 \text{ Volts}}$$

Individual displays will be present for each system, if CURRENT FEEDBACK ONE PER SYSTEM is programmed under the OPTIONS key. Combined compressor current for each system is displayed.

### Oper Data Quick Reference List

The following table is a quick reference list for information available under the OPER DATA key.

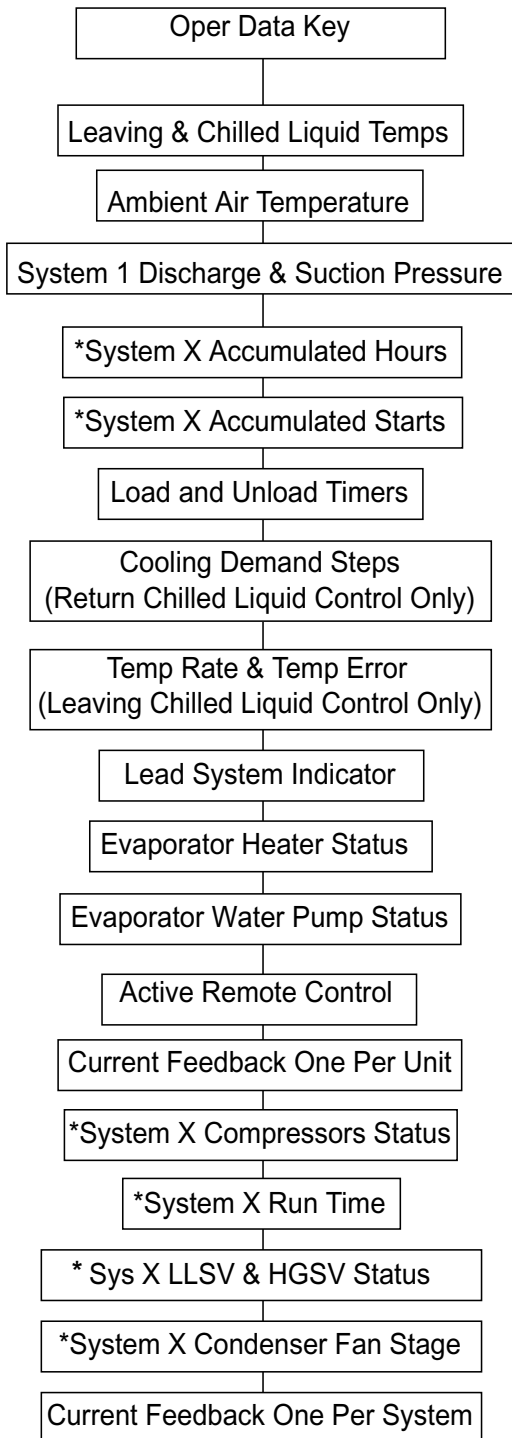

\* Block of information repeats for each system

LD12585

**FIGURE 34 - OPERATION DATA**

### Print Key

The PRINT key allows the operator to obtain a printout of real-time system operating data or a history printout of system data at the “instant of the fault” on the last six faults which occurred on the unit. An optional printer is required for the printout.

### Operating Data Printout

Pressing the PRINT key and then OPER DATA key allows the operator to obtain a printout of current system operating parameters. When the OPER DATA key is pressed, a snapshot will be taken of system operating conditions and panel programming selections. This data will be temporarily stored in memory and transmission of this data will begin to the printer. A sample Operating Data printout is shown below. (Note: Not all values are printed for all models.)

YORK INTERNATIONAL CORPORATION	
MILLENNIUM LIQUID CHILLER	
UNIT STATUS	
2:04PM 01 OCT 07	
SYS 1	NO COOLING LOAD
SYS 2	COMPRESSORS RUNNING 2
OPTIONS	
CHILLED LIQUID	WATER
AMBIENT CONTROL	STANDARD
LOCAL/REMOTE MODE	REMOTE
CONTROL MODE	LEAVING LIQUID
LEAD/LAG CONTROL	AUTOMATIC
FAN CONTROL	AMB & DSCH PRESS
CURRENT FEEDBACK	NONE
POWER FAILURE RESTART	AUTOMATIC
SOFT START	ENABLED
EXPANSION VALVE	THERMOSTATIC
REMOTE TEMP RESET	4 TO 20 MA
PROGRAM VALUES	
DSCH PRESS CUTOUT	570 PSIG
SUCT PRESS CUTOUT	80 PSIG
SUCT PRESS CUT COOLING	42 PSIG
SUCT PRESS CUT HEATING	31 PSIG
LOW AMBIENT CUTOUT	25.0 DEGF
LEAVING LIQUID CUTOUT	25.0 DEGF
ANTI RECYCLE TIME	600 SECS
FAN CONTROL ON PRESS	425 PSIG
FAN DIFF OFF PRESS	125 PSIG
NUMBER OF COMPRESSORS	6
NUMBER OF FANS PER SYSTEM	4
UNIT TRIP VOLTS	3.0
REFRIGERANT TYPE	R-22
DEFROST INIT TEMP	41.0 DEGF
DEFROST INITIATION TIME	60MIN
DEFROST TERMINATION TIME	3MIN
BIVALENT HEAT DELAY TIME	30 MIN
REMOTE UNIT ID PROGRAMMED	2
YORK HYDRO KIT PUMPS	1 (410a)
PUMP TOTAL RUN HOURS XXXXX	(410a)
UNIT DATA	
RETURN LIQUID TEMP	58.2 DEGF
LEAVING LIQUID TEMP	53.0 DEGF
DISCHARGE AIR TEMP	55.3 DEGF

```

COOLING RANGE 42.0 +/- 2.0 DEGF
HEATING RANGE 122.0 +/- 2.0 DEGF
SYS 1 SETPOINT 70 +/- 3 PSIG
SYS 2 SETPOINT 70 +/- 3 PSIG
REMOTE SETPOINT 44.0 DEGF
AMBIENT AIR TEMP 74.8 DEGF
LEAD SYSTEM SYS 2
EVAPORATOR PUMP ON
EVAPORATOR HEATER OFF
ACTIVE REMOTE CONTROL NONE
LAST DEFROST SYS X DURATION XXXS
TIME TO SYS X DEFROST XX MIN
BIVALENT DELAY REMAINING XX MIN
UNIT XXX.X AMPS X.X VOLTS
SOFTWARE VERSION C.M02.13.00
    
```

SYSTEM 1 DATA

```

COMP STATUS 1=OFF 2=OFF 3=OFF
RUN TIME 0- 0- 0- 0 D-H-M-S
TIME YYYYYYY 0- 0- 0- 0 D-H-M-S
LAST STATE YYYYYYY
SUCTION PRESSURE 105 PSIG
DISCHARGE PRESSURE 315 PSIG
SUCTION TEMPERATURE 46.0 DEGF
SAT SUCTION TEMP 34.0 DEGF
SUCTION SUPERHEAT 12.0 DEGF
COOLER INLET REFRIG 31.6 DEGF
DEFROST TEMPERATURE 52.8 DEGF
LIQUID LINE SOLENOID OFF
MODE SOLENOID OFF
HOT GAS BYPASS VALVE OFF
CONDENSER FAN STAGE OFF
EEV OUTPUT 0.0 %
SYSTEM XXX.X AMPS X.X VOLTS
    
```

SYSTEM 2 DATA

```

COMP STATUS 1=ON, 2=OFF, 3=ON
RUN TIME 0-0-1-46 D-H-M-S
TIME YYYYYYY 0-0-0-0 D-H-M-S
LAST STATE YYYYYYY
SUCTION PRESSURE 110 PSIG
DISCHARGE PRESSURE 320 PSIG
SUCTION TEMPERATURE 49.3 DEGF
SAT SUCTION TEMP 36.0 DEGF
SUCTION SUPERHEAT 13.3 DEGF
COOLER INLET REFRIG 31.6 DEGF
DEFROST TEMPERATURE 52.8 DEGF
LIQUID LINE SOLENOID ON
MODE SOLENOID ON
CONDENSER FAN STAGE 3
EEV OUTPUT 63.2%
SYSTEM XXX.X AMPS X.X VOLTS
    
```

DAILY SCHEDULE

```

S M T W T F S *=HOLIDAY
SUN START=00:00AM STOP=00:00AM
MON START=00:00AM STOP=00:00AM
TUE START=00:00AM STOP=00:00AM
WED START=00:00AM STOP=00:00AM
THU START=00:00AM STOP=00:00AM
FRI START=00:00AM STOP=00:00AM
SAT START=00:00AM STOP=00:00AM
HOL START=00:00AM STOP=00:00AM
    
```

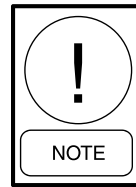

*See Optional Printer Installation on page 168 for Printer Installation information.*

### History Printout

Pressing the PRINT key and then the HISTORY key allows the operator to obtain a printout of information relating to the last 9 Safety Shutdowns which occurred. The information is stored at the instant of the fault, regardless of whether the fault caused a lockout to occur. The information is also not affected by power failures (long-term internal memory battery backup is built into the circuit board) or manual resetting of a fault lockout.

When the HISTORY key is pressed, a printout is transmitted of all system operating conditions which were stored at the “instant the fault occurred” for each of the 9 Safety Shutdowns buffers. The printout will begin with the most recent fault which occurred. The most recent fault will always be stored as Safety Shutdown No. 1. identically formatted fault information will then be printed for the remaining safety shutdowns.

Information contained in the Safety Shutdown buffers is very important when attempting to troubleshoot a system problem. This data reflects the system conditions at the instant the fault occurred and often reveals other system conditions which actually caused the safety threshold to be exceeded.

The history printout is similar to the operational data printout shown in the previous section. The differences are in the header and the schedule information. The daily schedule is not printed in a history print.

One example history buffer printout is shown following. The data part of the printout will be exactly the same as the operational data print so it is not repeated here. The difference is that the Daily Schedule is not printed in the history print and the header will be as follows.

```

YORK INTERNATIONAL CORPORATION
MILLENNIUM LIQUID CHILLER
SAFETY SHUTDOWN NUMBER 1
SHUTDOWN @ 3:56PM 29 SEP 07
SYS 1 HIGH DSCH PRESS SHUTDOWN
SYS 2 NO FAULTS
    
```

## History Displays

The HISTORY key gives the user access to many unit and system operating parameters at the time of a unit or system safety shutdown. When the HISTORY key is pressed the following message is displayed.

```
DISPLAY SAFETY SHUT-
DOWN NO. 1 (1 TO 9)
```

While this message is displayed, the ↑ (UP) arrow key can be used to select any of the six history buffers. Buffer number 1 is the most recent, and buffer number 6 is the oldest safety shutdown that was saved.

After selecting the shutdown number, pressing the ENTER key displays the following message which shows when the shutdown occurred.

```
SHUTDOWN OCCURRED
03:56 PM 29 JAN 02
```

The ↑ (UP) and ↓ (DOWN) arrow keys are used to scroll forward and backward through the history buffer to display the shutdown conditions stored at the instant the fault occurred. The ↓ (DOWN) arrow key scrolls through the displays in the order they appear below:

```
UNIT FAULT :
LOW LIQUID TEMP
```

Displays the type of fault that occurred.

```
UNIT TYPE
LIQUID CHILLER
```

Displays the type of chiller; Liquid, Condensing Unit or Heat Pump.

```
CHILLED LIQUID
XXXXX
```

Displays the chilled liquid type; Water or Glycol.

```
AMBIENT CONTROL
XXXXXXXXXX
```

Displays the type of Ambient Control; Standard or Low Ambient.

```
LOCAL / REMOTE MODE
XXXXXXXXXX
```

Displays Local or Remote control selection.

```
CONTROL MODE
LEAVING LIQUID
```

Displays the type of chilled liquid control; Leaving or Return.

```
LEAD / LAG CONTROL
XXXXXXXXXX
```

Displays the type of lead/lag control; Manual System 1, Manual System 2 or Automatic. This is only selectable on 2-system chillers.

```
FAN CONTROL
DISCHARGE PRESSURE
```

Displays the type of fan control; Discharge Pressure or Ambient and Discharge Pressure.

```
MANUAL OVERRIDE MODE
XXXXXXXXXX
```

Displays whether Manual Override was Enabled or Disabled.

```
CURRENT FEEDBACK
XXXXXXXXXXXXXXXXXX
```

Displays type of Current Feedback utilized.

```
SOFT START
XXXXXX
```

Displays whether the optional European Soft Start was installed and selected.

```
DISCHARGE PRESSURE
CUTOUT = XXXX PSIG
```

Displays the programmed Discharge Pressure Cutout.

```
SUCTION PRESSURE
CUTOUT = XXXX PSIG
```

Displays the programmed Suction Pressure Cutout.

```
LOW AMBIENT TEMP
CUTOUT = XXX.X °F
```

Displays the programmed Low Ambient Cutout.

**LEAVING LIQUID TEMP  
 CUTOUT = XXX.X °F**

Displays the Leaving Liquid Temp. Cutout programmed.

**FAN CONTROL ON  
 PRESSURE = XXX PSIG**

Displays the programmed Fan On Pressure.

**FAN DIFFERENTIAL OFF  
 PRESSURE = PSIG**

Displays the programmed Fan Off Differential.

**SYS 1 TRIP VOLTS  
 = X.X VOLTS**

Displays the programmed High Current Trip Voltage.

**SYS 2 TRIP VOLTS  
 = X.X VOLTS**

Displays the programmed High Current Trip Voltage.

**YORK HYDRO  
 KIT PUMPS = X**

Indicates the Pump Control option is selected.

**LCHLT = XXX.X °F  
 RCHLT = XXX.X °F**

Displays the Leaving and Return chilled Liquid Temperature at the time of the fault.

**SETPOINT = XXX.X °F  
 RANGE = +/- °F**

Displays the programmed Setpoint and Range, if the chiller is programmed for leaving chilled liquid control.

**SETPOINT = XXX.X °F  
 RANGE = +XX.X °F**

Displays the programmed Setpoint and Range, if the chiller is programmed for return chilled liquid control.

**AMBIENT AIR TEMP  
 = XXX.X °F**

Displays the Ambient Temp. at the time of the fault.

**LEAD SYSTEM IS  
 SYSTEM NUMBER X**

Displays which system is in the lead at the time of the fault.

**EVAPORATOR HEATER  
 STATUS IS XXX**

Displays status of the Evaporator Heater at the time of the fault.

**EVAPORATOR WATER  
 PUMP STATUS XXXX**

Displays status of Evaporator Water Pump at the time of fault. Status may read ON, OFF or trip.

**EVAP PUMP TOTAL RUN  
 HOURS = XXXX**

Evap Pump total run hours at the time of fault.

**ACTIVE REMOTE CTRL  
 XXXX**

Displays whether Remote Chiller Control was active when the fault occurred.

**UNIT ACTUAL AMPS  
 = XXX.X AMPS**

This is only displayed when the Current Feedback Option is one per unit.

**SYS X COMP STATUS  
 1 = XXX 2 = XXX 3 = XXX**

Displays which Compressors were running in the system when the fault occurred.

**SYS X RUN TIME  
 XX-XX-XX-XX D-H-M-S**

Displays the system run time when the fault occurred.

**SYS X SP = XXXX PSIG  
 DP = XXXX PSIG**

Displays the system Suction and Discharge Pressure of the time of the fault.

```
S Y S X S U C T = X X X . X ° F
S A T S U C T = X X X . X ° F
```

Displays the System Suction Temp and Saturated Suction Temp when an EEV is installed.

```
S Y S X L L S V I S X X X
H O T G A S S O L I S X X X
```

Displays whether the System Liquid Line Solenoid or Hot Gas Solenoid was energized at the time of the fault.

```
S Y S X F A N S T A G E X X X
```

Displays the number of Fan Stages in the system active at the time of the fault.

```
S Y S X A C T U A L A M P S
= X X X . X A M P S
```

Displays the system Amperage (calculated approximately) at the time of the fault.

For this message to appear, CURRENT FEEDBACK ONE PER SYSTEM must be programmed under the OPTIONS key. If the microprocessor is programmed as one CURRENT FEEDBACK ONE PER UNIT un-

der the PROGRAM key, the display will be the first display prior to the SYS 1 info. If the microprocessor is programmed for CURRENT FEEDBACK NONE, no current display will appear.

Displays for System 1 starting with SYS X NUMBER OF COMPS RUNNING X through SYS X AMPS = XXX.X VOLTS = X.X will be displayed first, followed by displays for System 2.

Further explanation of the above displays is covered under the STATUS, OPER DATA, COOLING SETPOINTS, PROGRAM, and OPTIONS keys.

### Software Version

The software version may be viewed by first pressing the HISTORY key and then repeatedly pressing the ↓ (DOWN) arrow key until you scroll past the first history buffer choice.

```
D I S P L A Y S A F E T Y S H U T -
D O W N N O . 1 ( 1 T O 6 )
```

After the ↓ (DOWN) arrow key is pressed again, the software version will appear.

```
C O N T R O L C M X X . Z Z . Y Y
I / O C M X X . 1 8 . Y Y
```

## ENTRY KEYS

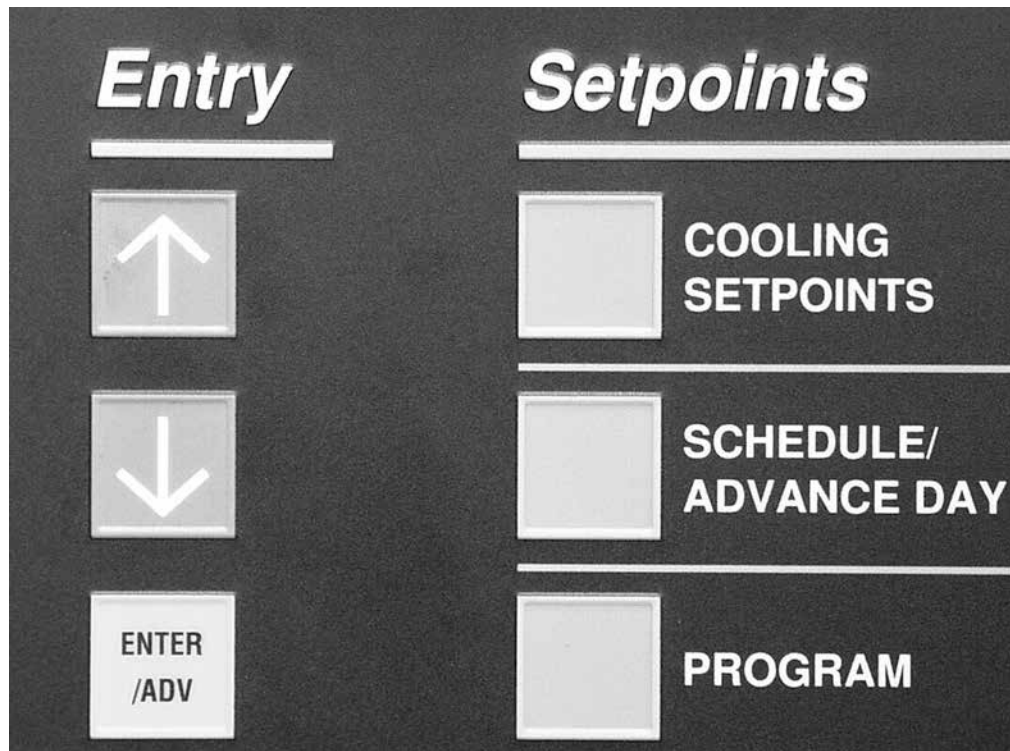

00068VIP

The Entry Keys allows the user to view, change programmed values. The ENTRY keys consist of an ↑ (UP) arrow key, ↓ (DOWN) arrow key, and an ENTER/ADV key.

### Up and Down Arrow Keys

Used in conjunction with the OPER DATA, HISTORY, COOLING SETPOINTS, SCHEDULE/ADVANCE DAY, OPTIONS and CLOCK keys, the ↑ (UP) and ↓ (DOWN) arrow keys allow the user to scroll through the various data screens. See *Display/Print Keys on page 115* for specific information on the displayed information and specific use of the ↑ (UP) and ↓ (DOWN) arrow keys.

The ↑ (UP) arrow key, and ↓ (DOWN) arrow key are also used for programming the control panel such as changing numerical or text values when programming cooling setpoints, setting the daily schedule, changing safety setpoints, chiller options, and setting the clock.

### Enter/Adv Key

The ENTER/ADV key must be pushed after any change is made to the cooling setpoints, daily schedule, safety setpoints, chiller options, and the clock. Pressing this key “enters” the new values into memory. If the ENTER/ADV key is not pressed after a value is changed, the changes will not be “entered” and the original values will be used to control the chiller.

Programming and a description on the use of the ↑ (UP) arrow key, and ↓ (DOWN) arrow, and ENTER/ADV keys are covered in detail under the SETPOINTS, and UNIT keys.

## SETPOINTS KEYS

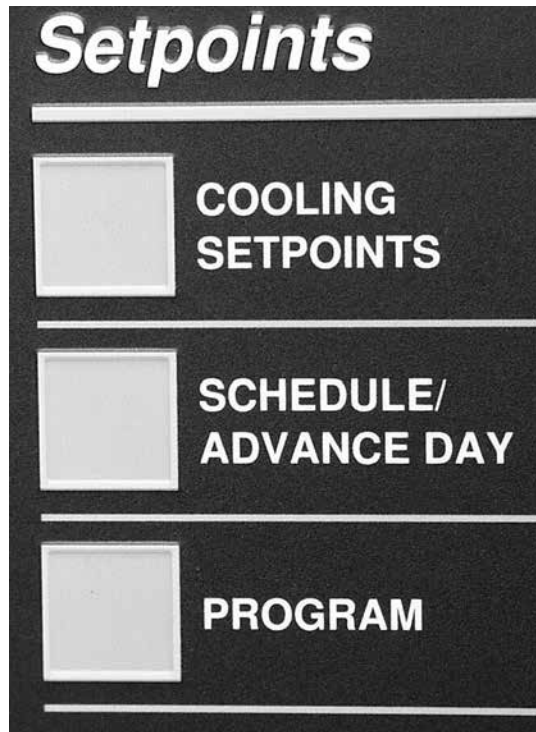

00069VIP

Programming of the cooling setpoints, daily schedule, and safeties is accomplished by using the keys located under the SETPOINTS section.

The three keys involved are labeled COOLING SETPOINTS, SCHEDULE/ADVANCE DAY, and PROGRAM.

Following are instructions for programming the respective setpoints. The same instruction should be used to view the setpoints with the exception that the setpoint will not be changed.

### Cooling Setpoints

The Cooling Setpoint and Range can be programmed by pressing the COOLING SETPOINTS key. The cooling mode (leaving chilled liquid or return chilled liquid) will be displayed for a few seconds, and the setpoint display entry screen will appear.

### Leaving Chilled Liquid Control

```

S E T P O I N T   =   4 5 . 0 ° F
R A N G E       =   +/- 2 . 0 ° F
  
```

The above message shows the current chilled water temperature SETPOINT at 45.0 °F (notice the cursor positioned under the number 0). Pressing either the ↑ (UP) or ↓ (DOWN) arrow will change the setpoint in .5 °F increments. After using the ↑ (UP) or ↓ (DOWN) arrow keys to adjust to the desired setpoint, the ENTER/ADV key must be pressed to enter this number into memory and advance to the RANGE SETPOINT.

Entry of the setpoint will be indicated by the cursor moving under the current RANGE setpoint. The ↑ (UP) and ↓ (DOWN) arrow keys are used to set the RANGE, in .5 °F increments, to the desired RANGE setpoint. After adjusting the setpoint, the ENTER/ADV key must be pressed to enter the data into memory.

Notice that the RANGE was programmed for +/- X.X° F. This indicates the SETPOINT to be in the *center* of

the control range. If the control mode has been programmed for RETURN LIQUID control, the message below would be displayed in place of the previous message.

When in leaving chilled liquid temperature control, the microprocessor will attempt to control the leaving water temperature within the temperature range of the setpoint + or – the range. In the above example, control will be in the range of 43 to 47 °F.

### Return Chilled Liquid Control

```

    SETPOINT = 45.0 °F
    RANGE    = +10.0 °F
    
```

In return chilled liquid control, the range no longer has a +/- X.X °F, but only a + X.X °F RANGE setpoint. This indicates that the setpoint is not centered within the RANGE but could be described as the bottom of the control range. A listing of the limits and the programmable values for the COOLING SETPOINTS are shown in *Table 19 on page 151*.

The SETPOINT and RANGE displays just described were based on LOCAL control. If the unit was programmed for REMOTE control (under the OPTIONS key), the above programmed setpoints would have no effect.

When in return chilled liquid temperature control, the microprocessor will turn all compressors OFF at setpoint and will turn compressors ON as return chilled liquid temperature rises. All compressors will be on at setpoint plus the range. If the range equals the temperature drop across the evaporator when fully loaded, the leaving chilled liquid temperature will remain near the setpoint plus or minus a few degrees as the chiller loads and unloads according to return chilled liquid temperature.

Both LEAVING and RETURN control are described in detail under *Capacity Control on page 149*.

### Remote Setpoint Control

Pressing the COOLING SETPOINTS key a second time will display the remote setpoint and cooling range. This display automatically updates about every 2 seconds. Notice that these setpoints are not “locally” programmable, but are controlled by a remote device such as an ISN control, remote reset option board, or remote PWM signal. These setpoints would only be valid if the unit was operating in the REMOTE mode.

The following messages illustrate both leaving chilled liquid control and return chilled liquid control respectively.

```

    REM SETP = 44.0 °F
    RANGE    = +/- 2.0 °F
    
```

(leaving chilled liquid control)

```

    REM SETP = 44.0 °F
    RANGE    = +10.0 °F
    
```

(return chilled liquid control)

The low limit, high limit, and default values for the keys under “SETPOINTS” are listed in *Table 19 on page 151*.

Pressing the COOLING SETPOINTS a third time will bring up the display that allows the Maximum EMS-PWM Temperature Reset to be programmed. This message is shown below.

```

    MAX EMS - PWM REMOTE
    TEMP RESET = +20 °F
    
```

The Temp Reset value is the maximum allowable remote reset of the temperature setpoint. The setpoint can be reset upwards by the use of an Energy Management System or from the Temperature Reset Option Board. See *Remote BAS/EMS Temperature Reset Using a Voltage or Current Signal on page 159* for a detailed explanation of this feature.

As with the other setpoints, the ↑ (Up) arrow and ↓ (Down) arrow keys are used to change the Temp Reset value. After using the ↑ (UP) and ↓ (DOWN) arrows to adjust to the desired setpoint, the ENTER/ADV key must be pressed to enter this number into memory.

### SCHEDULE/ADVANCE DAY KEY

The SCHEDULE is a seven day daily schedule that allows one start/stop time per day. The schedule can be programmed Monday through Sunday with an alternate holiday schedule available. If no start/stop times are programmed, the unit will run on demand, providing the chiller is not shut off on a unit or system shutdown. The daily schedule is considered “not programmed” when the times in the schedule are all zeros (00:00 AM).

To set the schedule, press the SCHEDULE/ADVANCE DAY key. The display will immediately show the following display.

**TABLE 12 - COOLING SETPOINT, PROGRAMMABLE LIMITS AND DEFAULTS**

SETPOINT KEY	MODE	LOW LIMIT	HIGH LIMIT	DEFAULT
LEAVING CHILLED LIQUID SETPOINT	WATER COOLING	40.0°F 4.4°C	**70.0°F 21.1°C	44.0°F 6.7°C
	GLYCOL COOLING*	10.0°F -12.2°C	**70.0°F 21.1°C	44.0°F 6.7°C
LEAVING CHILLED LIQUID CONTROL RANGE	—	1.5°F 0.8°C	2.5°F 1.4°C	2.0°F 1.1°C
RETURNED CHILLED LIQUID SETPOINT	WATER COOLING	40.0°F 4.4°C	70.0°F 21.1°C	44.0°F 6.7°C
	GLYCOL COOLING*	10.0°F -12.2°C	70.0°F 21.1°C	44.0°F 6.7°C
RETURN CHILLED LIQUID CONTROL RANGE	—	4.0°F 2.2°C	20.0°F 11.1°C	10.0°F 5.6°C
MAX EMS-PWM REMOTE TEMPERATURE RESET	—	2°F 1.0°C	40°F 22.0°C	20°F 11.0°C

\* See Engineering Guide for operation below 30°F (-1.1°C). Alternate thermal expansion valves must be used below 30°F (-1.1°C).

\*When using glycol, Leaving Chilled Liquid Setpoint should not be set below 20°F (-6.7°C).

\*\*Do not exceed 55°F (12.8°C) setpoint before contacting the nearest Johnson Controls Office for application guidelines.

```

MON START = 00 : 00 AM
          STOP = 00 : 00 AM

```

The line under the 0 is the cursor. If the value is wrong, it may be changed by using the ↑ (UP) and ↓ (DOWN) arrow keys until correct. Pressing the ENTER/ADV key will enter the times and then move the cursor to the minute box. The operation is then repeated if necessary. This process may be followed until the hour, minutes, and meridian (AM or PM) of both the START and STOP points are set. After changing the meridian of the stop time, pressing the ENTER/ADV key will advance the schedule to the next day.

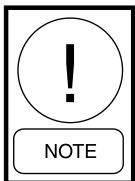

***Whenever the daily schedule is changed for Monday, all the other days will change to the new Monday schedule. This means if the Monday times are not applicable for the whole week then the exceptional days would need to be reprogrammed to the desired schedule.***

To page to a specific day, press the SCHEDULE/ADVANCE DAY key until the desired day appears. The start and stop time of each day may be programmed differently using the ↑ (UP) and ↓ (DOWN) arrow, and ENTER/ADV keys.

After SUN (Sunday) schedule appears on the display a subsequent press of the SCHEDULE/ADVANCE DAY key will display the Holiday schedule. This is a two part display. The first reads:

```

HOL START = 00 : 00 AM
          STOP = 00 : 00 AM

```

The times may be set using the same procedure as described above for the days of the week. After changing the meridian of the stop time, pressing the ENTER/ADV key will advance the schedule to the following display:

```

S _ M T W T F S
HOLIDAY NOTED BY *

```

The line below the empty space next to the S is the cursor and will move to the next empty space when the ENTER/ADV key is pressed. To set the Holiday, the cursor is moved to the space following the day of the week of the holiday and the ↑ (UP) arrow key is pressed. An \* will appear in the space signifying that day as a holiday. The \* can be removed by pressing the ↓ (DOWN) arrow key.

The Holiday schedule must be programmed weekly – once the Holiday schedule runs, it will revert to the normal daily schedule.

## PROGRAM KEY

There are several operating parameters under the PROGRAM key that are programmable. These setpoints can be changed by pressing the PROGRAM key, and then the ENTER/ADV key to enter *Program Mode*. Continuing to press the ENTER/ADV key will display each operating parameter. While a particular parameter is being displayed, the ↑ (UP) and ↓ (DOWN) arrow keys can be used to change the value. After the value is changed, the ENTER/ADV key must be pressed to enter the data into memory. *Table 13 on page 128* shows the programmable limits and default values for each operating parameter.

Following are the displays for the programmable values in the order they appear:

D I S C H A R G E      P R E S S U R E  
 C U T O U T   =   3 9 5   P S I G

DISCHARGE PRESSURE CUTOUT is the discharge pressure at which the system will shutdown as monitored by the optional discharge transducer. This is a software shutdown that acts as a backup for the mechanical high pressure switch located in the refrigerant circuit. The system can restart when the discharge pressure drops 40 PSIG (2.76 barg) below the cutout point.

If the optional discharge pressure transducer is not installed, this programmable safety would not apply. It should be noted that every system has a mechanical high pressure cutout that protects against excessive high discharge pressure regardless of whether or not the optional discharge pressure is installed.

S U C T I O N      P R E S S U R E  
 C U T O U T   =   8 0 . 0   P S I G

The SUCTION PRESSURE CUTOUT protects the chiller from an evaporator freeze-up. If the suction pressure drops below the cutout point, the system will shut down. Typically, the cutout should be set to 80 PSIG (5.52 Bars) form water cooling.

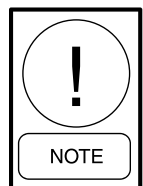

*There are some exceptions when the suction pressure is permitted to temporarily drop below the cutout point. Details are explained under the topic of SYSTEM SAFETIES.*

L O W   A M B I E N T   T E M P  
 C U T O U T   =   2 5 . 0   ° F

The LOW AMBIENT TEMP CUTOUT allows the user to select the chiller outside ambient temperature cutout point. If the ambient falls below this point, the chiller will shut down. Restart can occur when temperature rises 2 °F (1.11 °C) above the cutout setpoint.

L E A V I N G   L I Q U I D   T E M P  
 C U T O U T   =   3 6 . 0   ° F

The LEAVING LIQUID TEMP CUTOUT protects the chiller from an evaporator freeze-up. Anytime the leaving chilled liquid temperature drops to the cutout point, the chiller shuts down. Restart will be permitted when the leaving chilled liquid temperature rises 2 °F (1.11 °C) above the cutout setpoint.

When water cooling mode is programmed (OPTIONS key), the value is fixed at 36.0 °F (2.22 °C) and cannot be changed. Glycol cooling mode can be programmed to values listed in *Table 13 on page 128*.

A N T I   R E C Y C L E   T I M E R  
 =   6 0 0   S E C

The programmable anti-recycle timer assures that systems do not short cycle, and the compressor motors have sufficient time to dissipate heat after a start. This timer is programmable under the PROGRAM key between 300 and 600 seconds. Whenever possible, to reduce cycling and motor heating, the anti-recycle timer should be adjusted as high as possible. The programmable anti-recycle timer starts the timer when the first compressor in a system starts. The timer begins to count down. If all the compressors in the circuit cycle OFF, a compressor within the circuit will not be permitted to start until the anti-recycle timer has timed out. If the lead system has run for less than 5 minutes, 3 times in a row, the anti-recycle timer will be extended to 10 minutes, if currently programmed for less than 10 minutes.

F A N   C O N T R O L   O N  
 P R E S S U R E   =   X X X   P S I G

The Fan Control On Pressure is the programmed pressure value that is used to stage the condenser fans on, in relation to discharge pressure. See *Standard Condenser Fan Control on page 154* in SECTION 7 – UNIT CONTROLS and *Table 22 on page 156* and *Table 23 on page 157*.

**FAN DIFFERENTIAL OFF  
PRESSURE = XXX PSIG**

The Fan Differential Off Pressure is the programmed differential pressure value that is used to stage the condenser fans OFF, in relation to discharge pressure. See *Standard Condenser Fan Control* on page 154 in SECTION 8 – UNIT OPERATION and Table 22 on page 156 and Table 23 on page 157.

**TOTAL NUMBER OF  
COMPRESSORS = 6**

The TOTAL NUMBER OF COMPRESSORS is the total quantity of compressors in the chiller, and determines the stages of cooling available. Note in Table 13, the chiller may have single or dual systems. Single system units can have 2 or 3 compressors, while dual system units may have 4 or 6 compressors.

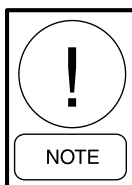

***This MUST be programmed correctly to assure proper chiller operation.***

**NUMBER OF FANS  
PER SYSTEM = X**

The Number of Fans Per System must be programmed as needed to match the number of fans on each system.

**SYS X TRIP VOLTS  
= X.X VOLTS**

**UNIT TRIP VOLTS  
= X.X VOLTS**

**TABLE 13 - PROGRAM KEY LIMITS AND DEFAULT**

PROGRAM VALUE	MODE	LOW LIMIT	HIGH LIMIT	DEFAULT
DISCHARGE PRESSURE CUTOUT	—	325 PSIG	575 PSIG	570 PSIG
		22.4 BARG	39.6 BARG	39.3 BARG
SUCTION PRESSURE CUTOUT	WATER COOLING	80.0 PSIG	120.0 PSIG	80.0 PSIG
		5.52 BARG	8.27 BARG	5.52 BARG
	GLYCOL COOLING	42.0 PSIG	70.0 PSIG	44.0 PSIG
		2.9 BARG	4.83 BARG	3.03 BARG
LOW AMBIENT TEMP. CUTOUT	STANDARD AMBIENT	25.0 °F	60.0 °F	25.0 °F
		-3.9 °C	15.6 °C	-3.9 °C
	LOW AMBIENT	0 °F	60.0 °F	25.0 °F
		-17.8 °C	15.6 °C	-3.9 °C
LEAVING CHILLED LIQUID TEMP. CUTOUT	WATER COOLING	—	—	36 °F
		—	—	2.2 °C
	GLYCOL COOLING	-1.0 °F	36.0 °F	36.0 °F
		-18.3 °C	2.2 °C	2.2 °C
ANTI-RECYCLE TIMER	—	300 SEC.	600 SEC.	600 SEC.
FAN CONTROL ON PRESSURE	—	360 PSIG	485 PSIG	385 PSIG
		24.8 BARG	33.4 BARG	26.5 BARG
FAN DIFFERENTIAL OFF PRESSURE	—	80 PSID	160 PSID*	125 PSID
		5.51 BARD	11.03 BARD*	8.62 BARD
TOTAL NUMBER OF COMPRESSORS	SINGLE SYSTEM	2	3	3
	DUAL SYSTEM	4	6	6
NUMBER OF FANS PER SYSTEM	—	2	4	3
UNIT/SYSTEM TRIP VOLTS	CURRENT FEEDBACK	0.5 Volts	4.5 Volts	2.5 Volts
REMOTE UNIT ID	—	0	7	0

\* The minimum discharge pressure allowed is 235 PSIG. The Fan Differential Off Pressure High Limit will be lowered (reduced) to prevent going below 235 PSIG based on where the fan control On Pressure is programmed.

Depending on the option, the trip voltage for a specific system or unit high current trip can be programmed. It also calibrates the current read-out under the OPER DATA key. The approximate programmed value is calculated using the following formulas.

### System Trip Volts

For individual system high current trip programming on chillers:

- Add the sum of the compressor and fan RLA's in the system
- Multiply the sum by 1.25
- Divide by 225A
- The resulting voltage is the value that should be programmed

For example, if fan and compressor RLA's total 100A:

$$\frac{5V \times 100A}{225A} \times 1.25 = \frac{625VA}{225A} = 2.8V$$

The programmed value will be 2.8V. A similar calculation and programming will be necessary for the other system in a 2-system chiller.

### Unit Trip Volts

For total chiller high current trip programming on 460VAC chillers:

- Add the sum of all the compressors and fan RLA's in the chiller
- Multiply the sum by 1.25
- Divide by 225A
- The resulting voltage is the value that should be programmed

For example, if fan and compressor RLA's total 180A:

$$\frac{5V \times 180A}{225A} \times 1.25 = \frac{1125VA}{225A} = 5.0V$$

The programmed value will be 5.0V.

**REMOTE UNIT ID  
PROGRAMMED = X**

When communications is required with a BAS or OptiView Panel, individual unit IDs are necessary for communications with specific chillers on a single RS-485 line. ID 0 - 7 is selectable.

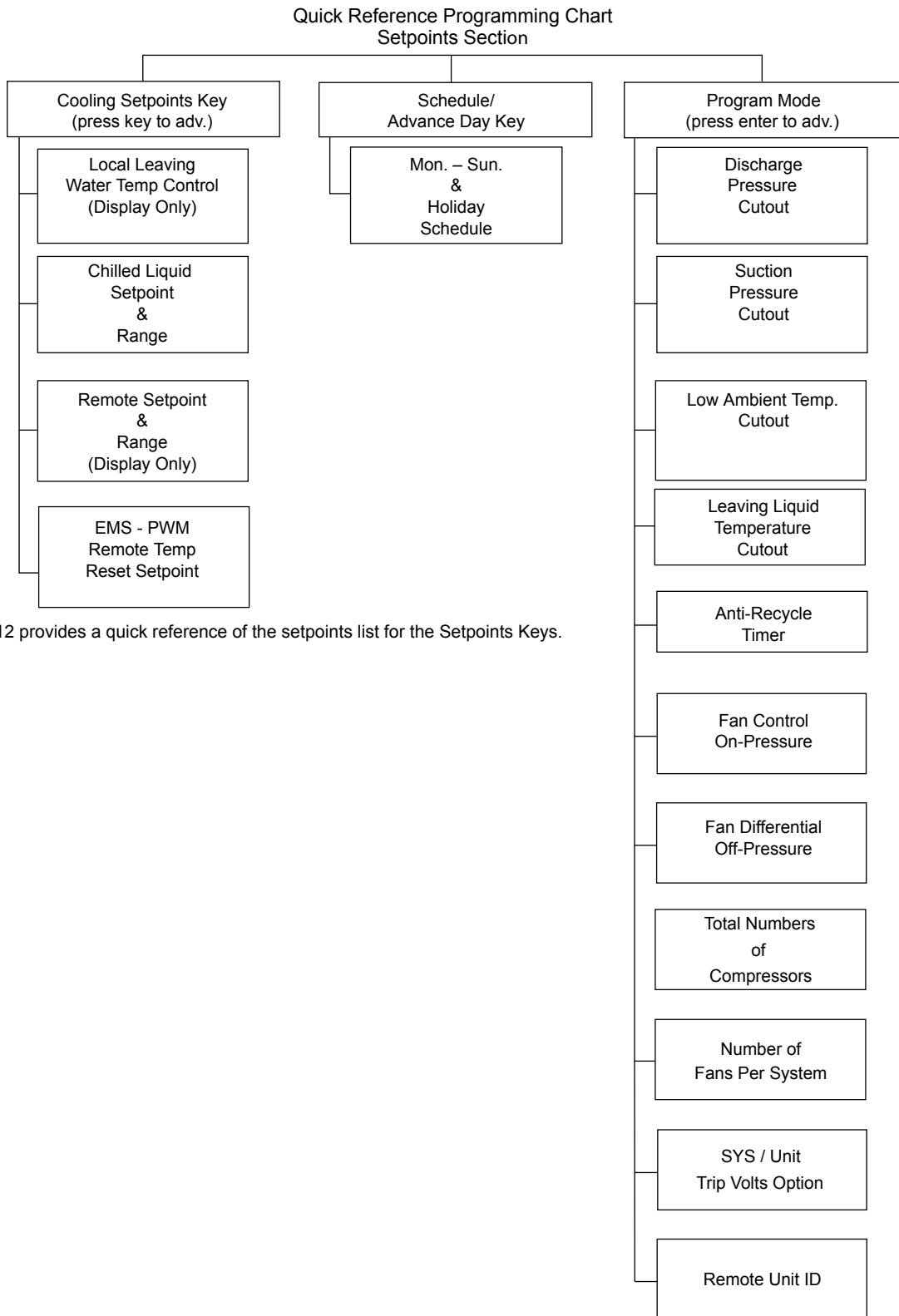
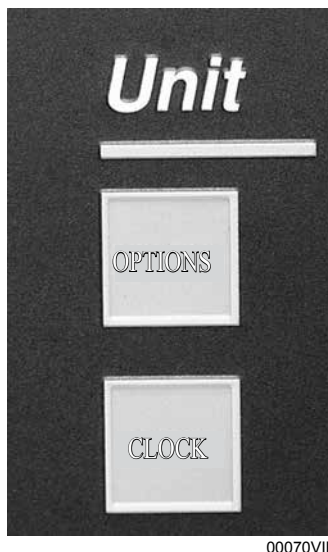

Table 12 provides a quick reference of the setpoints list for the Setpoints Keys.

LD07404c

**FIGURE 35 - SETPOINTS QUICK REFERENCE LIST**

## UNIT KEYS



### Options Key

There are many user programmable options under the OPTIONS key. The OPTIONS key is used to scroll through the list of options by repeatedly pressing the OPTIONS key. After the selected option has been displayed, the ↑ (UP) and ↓ (DOWN) arrow keys are then used to change that particular option. After the option is changed, the ENTER/ADV key must be pressed to enter the data into memory.

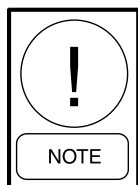

*Many of the OPTIONS displayed are only programmable under the SERVICE MODE and not under the OPTIONS key. Options only programmable under the SERVICE MODE are noted in the details describing the option.*

Figure 36 on page 136 shows the programmable options. Following are the displays in the order they appear:

#### Option 1 – Language



English, Spanish, French, German, and Italian can be programmed.

#### Option 2 – System Switches (two system units only)

(Single System Display is similar)



This allows both systems to run.

or



This turns system 2 OFF.



This turns system 1 OFF.

or



This turns systems 1 and 2 OFF.

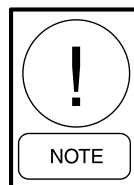

*Turning a system OFF with its system switch allows a pumpdown to be performed prior to shutdown.*

#### Option 3 – Chilled Liquid Cooling Type



The chilled liquid is water. The Cooling Setpoint can be programmed from 40 °F to 70 °F (4.4 °C to 21.1 °C)

or

C H I L L E D L I Q U I D  
G L Y C O L

The chilled liquid is glycol. The Cooling Setpoint can be programmed from 10 °F to 70 °F (-12.2 °C to 21.1 °C).

#### Option 4 – Ambient Control Type

A M B I E N T C O N T R O L  
S T A N D A R D

The low ambient cutout is adjustable from 25 °F to 60 °F (-3.9 °C to 15.6 °C).

or

A M B I E N T C O N T R O L  
L O W A M B I E N T

The low ambient cutout is programmable down to 0 °F (-17.8 °C). **A low ambient kit MUST be installed for this option to be chosen. If the kit is NOT installed, and low ambient is selected, low pressure faults and compressor damage may occur.**

#### Option 5 – Local/Remote Control Type

L O C A L / R E M O T E M O D E L  
L O C A L

When programmed for LOCAL, an ISN or RCC control can be used to monitor only. The micro panel will operate on locally programmed values and ignore all commands from remote devices, or through the RS-485 inputs. The chiller will communicate and send data to the remote monitoring devices.

or

L O C A L / R E M O T E M O D E  
R E M O T E

This mode should be selected when an ISN or RCC control is to be used to control the chiller. This mode will allow the ISN to control the following items: Remote Start/Stop, Cooling Setpoint, Load Limit, and History Buffer Request. If the unit receives no valid ISN transmission for 5 minutes, it will revert back to the locally programmed values.

#### Option 6 – Unit Control Mode

C O N T R O L M O D E  
R E T U R N L I Q U I D

Unit control is based on return chilled liquid temp. Return Chilled Liquid Control can only be selected on units that have 4 to 6 compressors (dual system units).

or

C O N T R O L M O D E  
L E A V I N G L I Q U I D

#### Option 7 – Display Units

D I S P L A Y U N I T S  
I M P E R I A L

This mode displays system operating values in Imperial units of °F or PSIG.

or

D I S P L A Y U N I T S  
S I

This mode displays system operating values in Scientific International Units of °C or barg.

#### Option 8 – Lead/Lag Type (two system units only)

L E A D / L A G C O N T R O L  
M A N U A L S Y S 1 L E A D

SYS 1 selected as lead compressor. SYS 1 lead option MUST be chosen if Hot Gas Bypass is installed.

or

L E A D / L A G C O N T R O L  
M A N U A L S Y S 2 L E A D

SYS 2 selected as lead compressor.

or

L E A D / L A G C O N T R O L  
A U T O M A T I C

Lead/lag between systems may be selected to help equalize average run hours between systems on chillers with 2 refrigerant systems. Auto lead/lag allows automatic lead/lag of the two systems based on an average run hours of the compressors in each system. A new lead/lag assignment is made whenever all compressors shut down. The microprocessor will then assign the “lead” to the system with the shortest average run time.

### Option 9 – Condenser Fan Control Mode

FAN CONTROL  
DISCHARGE PRESSURE

Condenser fans are controlled by discharge pressure only. This mode must be chosen.

or

FAN CONTROL  
AMBIENT & DSCH PRESS

Do not select this option on R-410A chillers.

### Option 10 – Manual Override Mode

MANUAL OVERRIDE MODE  
DISABLED

This option allows overriding of the daily schedule that is programmed. MANUAL OVERRIDE MODE – DISABLED indicates that override mode has no effect.

or

MANUAL OVERRIDE MODE  
ENABLED

Manual Override Mode is enabled. This is a service function and when enabled, will allow the unit to start when shut down on the daily schedule. It will automatically be disabled after 30 minutes.

### Option 11 – Current Feedback Options Installed

CURRENT FEEDBACK  
NONE

This mode should be selected when the panel is not equipped with current sensing capability.

or

CURRENT FEEDBACK  
ONE PER UNIT

This mode should be selected when an optional 2ACE Module is installed to allow combined current monitoring of all systems by sensing current on the incoming line.

or

CURRENT FEEDBACK  
ONE PER SYSTEM

This mode should be selected when an optional 2ACE module is installed to allow individual current monitoring of each system. SYS 1 input is to J7 of the I/O. SYS 2 input is to J8 of the I/O.

### Option 12 – Power Fail Restart

POWER FAIL RESTART  
AUTOMATIC

Chiller auto restarts after a power failure.

POWER FAIL RESTART  
MANUAL

After a power failure, the UNIT switch must be toggled before restart at the unit is allowed. NORMALLY MANUAL RESTART should NOT BE SELECTED.

### Option 13 – Soft Start Enable/Disable

SOFT START  
DISABLED

SOFT START “DISABLED” MUST be selected on all chillers.

This message may not be viewable on non-European chillers.

### Option 14 – Unit Type

UNIT TYPE  
LIQUID CHILLER

The UNIT TYPE message cannot be modified under the unit keys.



“Liquid CHILLER” must be displayed, or damage to compressors or other components will occur if operated in the HEAT PUMP or CONDENSING UNIT modes.

If unit type needs to be changed to make the unit a liquid chiller, remove power and then remove the jumper between J11-7 and J11-12 on the I/O Board. Reapply power to the micro panel and the microprocessor will store the change.

**Option 15 – Refrigerant Type**

REFRIGERANT TYPE  
R - 410 A

Refrigerant type R-410A must be selected under Service Mode. Refrigerant type is displayed under the OPTIONS key, but is only programmable in Service Mode.



*Incorrect programming may cause damage to compressors.*

**Option 16 – Expansion Valve Type**

EXPANSION VALVE TYPE  
THERMOSTATIC

Expansion valve type, thermostatic or electronic may be selected under Service Mode. Expansion valve type is displayed under the OPTIONS key, but is only programmable in Service Mode. YLAA chillers will typically always be equipped with thermostatic expansion valves.



*Incorrect programming may cause damage to compressors.*

Also see the UNIT KEYS PROGRAMMING QUICK REFERENCE LIST in *Figure 36 on page 136*.

**Option 17 – Flash Card Update**

FLASH CARD UPDATE  
DISABLED

A Flash Card is used to input the operating program into the chiller IPU. A Flash Card is used instead of an EPROM. Normally, a Flash Card update is not required and the message above will be displayed.

If the operating software is to be updated, insert the Flash Card into the Flash Card input port. Turn off the unit switch and set the FLASH CARD UPDATE TO “ENABLED” using the ↑ and ↓ keys.

FLASH CARD UPDATE  
ENABLED

Press the ENTER key and the following message will be displayed until the update has been completed. The keypad and display will not respond during the update. DO NOT reset or power down the chiller until the update is completed.

FLASH CARD UPDATING  
PLEASE WAIT . . .

After the update is completed, an automatic reboot will occur. If an error occurred, the following message will appear with the error code and no reboot will occur.

FLASH CARD UPDATE  
ERROR XXXXXX

If the update resulted in an error, the original program will still be active. When an error occurs, assure the correct Flash Card was utilized. Incorrect chiller software will cause an error. If this is not the case, the Flash Card is most likely defective or the IPU and I/O combo board is bad.

**Option 18 – Remote Temperature Reset**

REMOTE TEMP RESET  
INPUT XXXXXXXXXXXXXXXX

Remote Temp Reset input selection is programmable according to the type of input utilized. The following options are available:

- DISABLED (default)
- 0.0 – 10.0 (DC)
- 2.0 – 10.0V (DC)
- 0.0 – 20.0 mA
- 4.0 – 20.0 mA

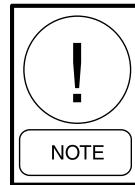

*The options display message for Remote Temp Reset Input only appears if the Temp Reset Option is enabled under Service Mode. The option must be enabled under the Service Mode for the Remote Temperature Reset to operate.*

### Option 19 – Pump Control

Pump Control is utilized to operate the optional on-board pump kit or to control an external pump through dry contacts 23 and 24 on Terminal Block XTBC2. To use this option, the following selection should be made in the Service Mode:



When YORK HYDRO KIT PUMPS = 1, the controls will be closed to run the pumps whenever any one of the following conditions are true:

- Low Leaving Chilled Liquid Fault
- Any compressor is running
- Daily Schedule is ON and Remote Stop is closed.

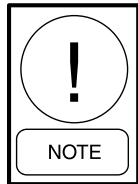

*Even if one of the above conditions are true, the pump will not run if the chiller has been powered up for less than 30 seconds; or if the pump has run in the last 30 seconds to prevent pump overheating.*



EXTERNAL EVAP PUMP should be selected if an external pump is being controlled with the chiller pump contacts. The operation will be the same as YORK HDRO KIT PUMPS = 1

The following option should not be selected.



### Option 20 – Pump Selection

The displays for this PUMP SELECTION option should only appear if “YORK HYDRO KIT PUMPS = 2” are selected under Option 19. Presently, this option should not be used.

#### Clock

The CLOCK display shows the current day, time, and date. Pressing the CLOCK key will show the current day, time, and date.

It is important that the date and time be correct, otherwise the daily schedule will not function as desired if programmed. In addition, for ease of troubleshooting via the History printouts, the day, time, and date should be correct.

To change the day, time, and date press the CLOCK key. The display will show something similar to the following:



The line under the F is the cursor. If the day is correct, press the ENTER/ADV key. The cursor will move under the 0 in 08 hours. If the day is incorrect, press the ↑ (UP) or ↓ (DOWN) arrow keys until the desired day is displayed and then press the ENTER/ADV key at which time the day will be accepted and the cursor will move under the first digit of the “2 digit hour”. In a similar manner, the hour, minute, meridian, month, day, and year may be programmed, whenever the cursor is under the first letter/numeral of the item. Press the ↑ (UP) or ↓ (DOWN) arrow keys until the desired hour, minute, meridian; day, month, and year are displayed. Pressing the ENTER/ADV key will save the value and move the cursor on to the next programmable variable.

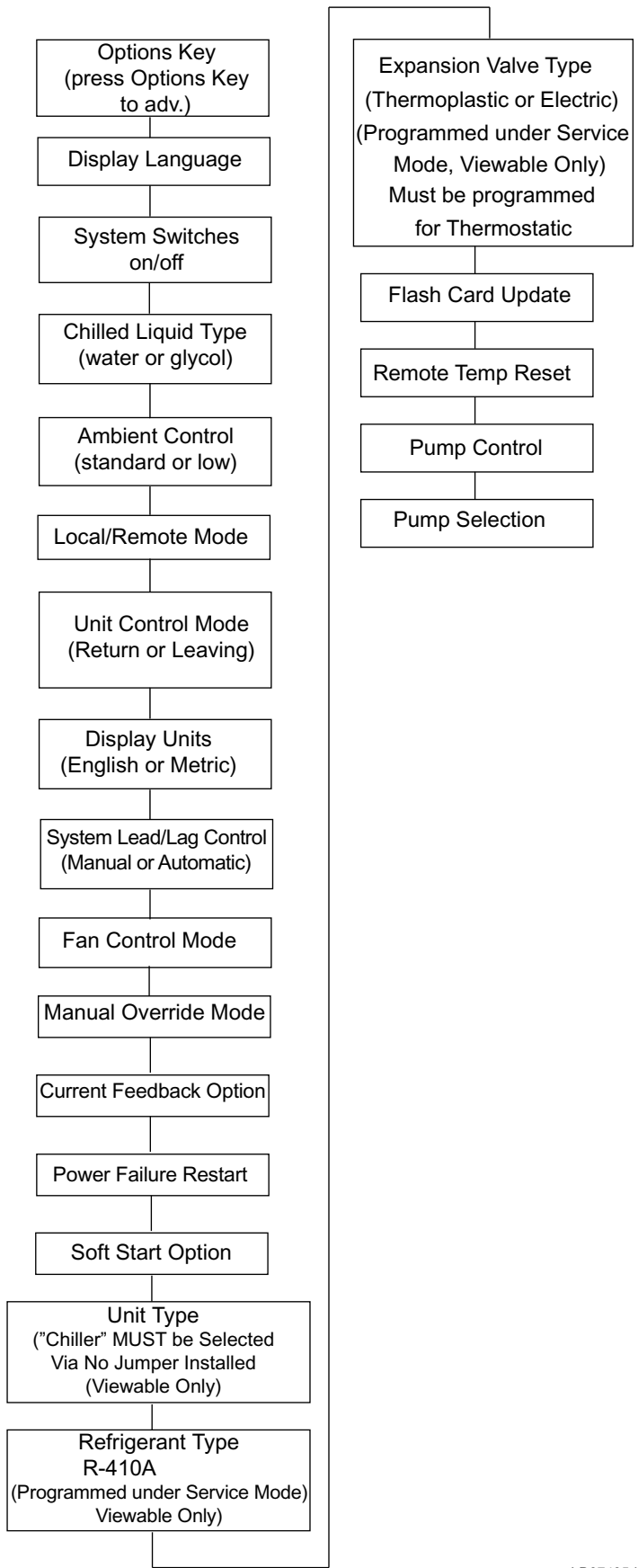

Figure 36 provides a quick reference list for the Unit key setpoints.

LD07405d

**FIGURE 36 - UNIT KEYS OPTIONS PROGRAMMING QUICK REFERENCE LIST**

## BACNET, MODBUS, N2 AND YORKTALK 2 COMMUNICATIONS

Data can be read and in some cases modified using a serial communication BACnet, Modbus or YorkTalk 2 network connection. This information allows communications of chiller operating parameters and external control changes to setpoint, load limiting, and start/stop commands.

BACnet and YorkTalk 2 RS485 networks are wired to the + and - terminals of TB1 for port 1 communications. Modbus network connection has the option of RS232 or RS485 connection for port 2 communications. Modbus network is wired to either TB2 or TB3 as follows:

- RS-485: connect to TB2 - Network (-1) to TB2 (-1); Network (+1) to TB2 (+1)
- RS-232: connect to TB3 - Network (RX) to TB3 (TXD); Network (TX) to TB3 (RXD); Network (GND) to TB3 (GND)

See Figure 37 on page 138 for TB1, TB2 and TB3 locations.

In most cases, communication parameters will need to be modified. Table 30 on page 139 lists setup parameters for the available protocols. Modification is accomplished by pressing the PROGRAM, DOWN ARROW, DOWN ARROW, DOWN ARROW, DOWN ARROW, and ENTER keys in sequence. The list below shows the displays for the values that may be modified:

DE MODIFIER ADDRESS XXXXXX	P2 PROTOCOL XXXXXXXXXX
DE MODIFIER OFFSET XX	P2 MANUAL MAC ADDRESS XXX
P1 PROTOCOL XXXXXX	P2 BAUD RATE XXXXX
P1 MANUAL MAC ADDRESS XXX	P2 PARITY XXXXX
P1 BAUD RATE XXXXXX	P2 STOP BITS X
P1 PARITY XXXXXX	P2 HW SELECT BIT XXXXX
P1 STOP BITS X	REAL TIME ERROR ## RESET 1 = YES, 0 = NO 0

Note: See Table 16 on page 140 for error descriptions

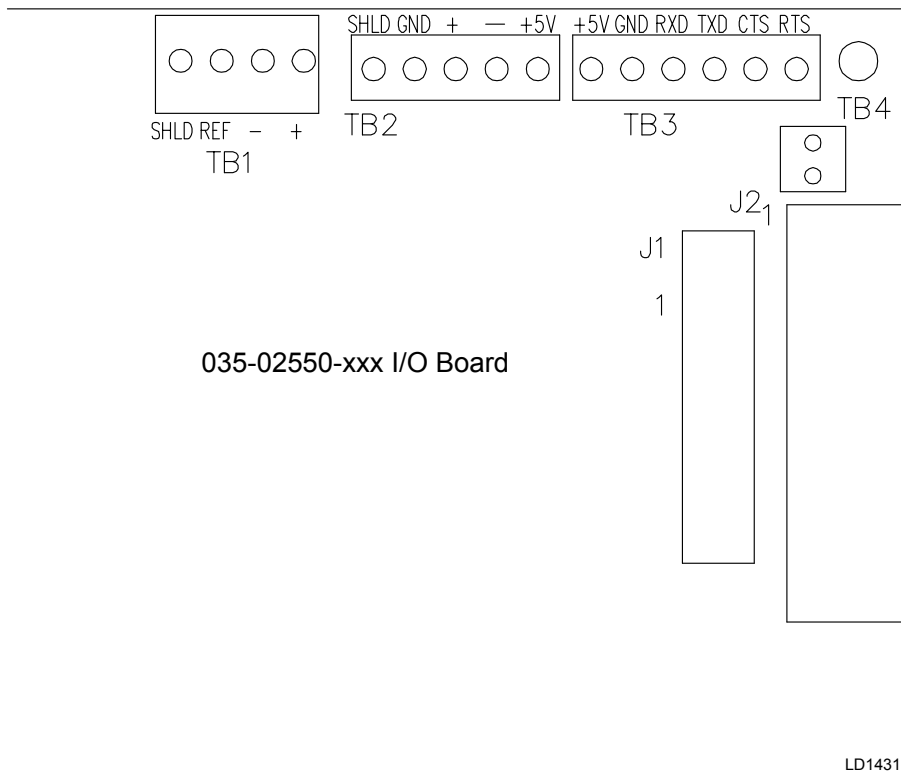

**FIGURE 37 - MICRO PANEL CONNECTIONS**

The table below shows the minimum, maximum, and default values.

**TABLE 14 - MINIMUM, MAXIMUM AND DEFAULT VALUES**

DESCRIPTION	MINIMUM	MAXIMUM	DEFAULT
DE MODIFIER ADDRESS	-1	41943	-1
DE MODIFIER OFFSET	-1	99	-1
P1 BAUD RATE	1200	76800	4800
	1200, 4800, 9600, 19200, 38400, 76800, AUTO SELECTABLE		
P2 BAUD RATE	1200	57600	1200
	1200, 4800, 9600, 19200, 38400, 57600 SELECTABLE		
P1, P2 MANUAL Mac ADDRESS	-1	127	-1
P1, P2 PARITY	NONE	IGNORE	NONE
	NONE, EVEN, ODD, IGNORE SELECTABLE		
P1 PROTOCOL	BACNET	API	BACNET
	BACNET, API SELECTABLE		
P2 PROTOCOL	TERMINAL	MODBUS CLIENT	API
	TERMINAL, MODBUS IO, MODBUS SERVER, API, MODBUS CLIENT SELECTABLE		
P1, P2 STOP BITS	1	2	1
RESET REAL TIME ERROR	NO	YES	NO

The table below shows set-up requirements for each communication protocol.

**TABLE 15 - VALUES REQUIRED FOR BAS COMMUNICATION**

SETTING DESCRIPTION	PROTOCOL			
	BACNET MS/TP	MODBUS RTU <sup>5</sup>	YORKTALK 2	N2 <sup>6</sup>
DE MODIFIER ADDRESS	0 to 41943 <sup>3</sup>	1	-1	0 to 41943 <sup>3</sup>
DE MODIFIER OFFSET	0 to 99 <sup>4</sup>	0	N/A	0 to 99 <sup>4</sup>
P1 PROTOCOL	BACNET	N/A	N/A	9n2
P1 MANUAL MAC ADDRESS	0-127 <sup>1</sup>	N/A	N/A	0-127 <sup>1</sup>
P1 BAUD RATE	9600 To 76800 or Auto Selectable <sup>1</sup>	N/A	N/A	9600
P1 PARITY	NONE	N/A	N/A	NONE
P1 STOP BITS	1	N/A	N/A	1
P2 PROTOCOL	N/A	MODBUS SVR	N/A	N/A
P2 MANUAL MAC ADDRESS	N/A	0-127 <sup>1</sup>	N/A	N/A
P2 BAUD RATE	N/A	19,200 <sup>2</sup>	N/A	N/A
P2 PARITY	N/A	NONE <sup>2</sup>	N/A	N/A
P2 STOP BITS	N/A	1	N/A	N/A
P2 HW SELECT BIT	N/A	RS-485 or RS-232 <sup>1</sup>	N/A	N/A
RESET REAL TIME ERROR	N/A	N/A	N/A	N/A
P1 HW SELECT BIT	N/A	N/A	N/A	N/A
CHILLER ID	N/A	N/A	0	N/A

1. As required by network. 2. Or other as required by network. 3. Number is multiplied by 100, set as required by network.
4. Number is added to de modifier address, set as required by network.
5. Unit operating software version C.Mmc.13.03 or later required for Modbus Protocol.
6. Unit operating software version 04 (C.MMC.13.04, C.MMC.14.04, or C.MMC.16.04) or higher required for N2 protocol functionality.

### BACnet and Modbus Communications

Chiller data that can be read and modified using specific BACnet or Modbus Register Addresses; and the data associated with the addresses, is outlined in the following description:

#### Analog Write Points

This data can be read and modified using a BACnet or Modbus network connection. The Modbus Register Address for these points is 1025 + AV #.

#### Binary Write Points

This data can be read and modified using a BACnet or Modbus network connection. The Modbus Register Address for these points is 1537 + BV #.

### Analog Read Only Points

This data can be read using a BACnet or Modbus network connection and can NOT be modified using this connection. The Modbus Register Address for these points is 513 + AI #.

### Binary Monitor Only Points

This data can be read using a BACnet or Modbus network connection and can NOT be modified using this connection. The Modbus Register Address for these points is 1281 + BI #.

See Table 17 on page 141 for complete list of BACnet and Modbus registers.

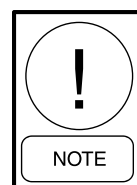

*The latest data map information is listed on the Johnson Controls Equipment Integration website.*

**Communications Data Map Notes***(See Table 17)*

1. IPU II based units are configured for Native BACnet MS/TP and Modbus RTU communications. E-Link Gateway not required for these two communication protocols.
2. BACnet Object Types:
 

0 = Analog In	5 = Binary Value
1 = Analog Out	8 = Device
2 = Analog Value	15 = Alarm Notification (0 through 127 are reserved ASHRAE Objects).
3 = Binary In	
4 = Binary Output	
3.
 

WC= Inches of water column	Pa = Pascals
CFM = Cubic Feet per Minute	kPa = Kilopascals
FPM = Feet per Minute	PPM = Part per Million
PSI = Lbs per square inch	kJ/kg = Kilojoules per Kilogram.
4. Water Cooled Scroll units use the same firmware as Air Cooled Scroll units, ignoring Fan Control.

The table below shows the real time error numbers that may be encountered during communication setup and a description of each.

**TABLE 16 - REAL TIME ERROR NUMBERS**

ERROR NUMBER (##)	DESCRIPTION
0	ALL OK
1	DATUM TYPE OK TEST FAILED
2	ENGLISH TEXT TOO LONG
3	FLOATING POINT EXCEPTION
4	GET PACKET FAILED
5	GET TYPE FAILED
6	INVALID UNIT CONVERSION
7	INVALID HARDWARE SELECTION
8	REAL TIME FAULT
9	SPANISH TEXT TOO LONG
10	THREAD EXITED
11	THREAD FAILED
12	THREAD STALLED
13	IO BOARD RESET
14	BRAM INVALID
15	BACNET SETUP FAILED

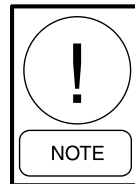

***Reboot required (cycle power) after settings are changed.***

**TABLE 17 - NATIVE BACNET, MODBUS AND N2 COMMUNICATIONS DATA MAP**

SCROLL CHILLER/HEATPUMP/CONDENSING UNIT				Modbus RTU, BACnet MS/TP, N2 Data Map		Board: 031-02550															
Item	BACnet Name	BACnet Object Instance	Modbus Address	Modbus Data Type Supported	Modbus Scaling (See Note 5)	N2 Metasys	Engineering Units	Point List Description													
Item Ref Num	BACnet Name	BACnet Object Instance	Modbus Address	Modbus Data Type Supported	Modbus Scaling (See Note 5)	N2 Metasys	Engineering Units	Imperial	SI	1	2	3	4	5	6	7	8	9	10		
<b>ANALOG WRITE POINTS</b>																					
1	REM_SETP	AV1	1026	03.06.16	Div 10	ADF 1	°F		°C											Remote Setpoint [99=Auto]	
2	SP_REM_SP_S1	AV2	1027	03.06.16	Div 10	ADF 2	PSI														Sys 1 Remote Setpoint (SP Unit)
3	LOAD_LIMIT	AV3	1028	03.06.16	Div 10	ADF 3	None														Load Limit Stage [0,1,2]
4	REM_CR	AV4	1029	03.06.16	Div 10	ADF 4	°F		°C												Remote Cooling Range (DAT Unit)
5	SP_REM_SP_S2	AV5	1030	03.06.16	Div 10	ADF 5	PSI														Sys 2 Remote Setpoint (SP Unit)
6	REM_SP_HEAT	AV6	1031	03.06.16	Div 10	ADF 6	°F		°C												Remote Heating Setpoint (HP or YCWL HP)
7	HP_MODE	AV7	1032	03.06.16	Div 10	ADF 7	None		None												Remote Heatpump Mode [0=Pni, 1=Cool, 2=Heat] (HP or YCWL HP)
<b>BINARY WRITE POINTS</b>																					
8	START_STOP	BV1	1538	01,03,05,06,15	N/A	BD 1	0/1	0/1	0/1												Remote Start/Stop Command [0=Stop, 1=Run]
9	SS_SYS1	BV2	1539	01,03,05,06,15	N/A	BD 2	0/1	0/1	0/1												Sys 1 Remote Start/Stop (SP Unit)
10	SS_SYS2	BV3	1540	01,03,05,06,15	N/A	BD 3	0/1	0/1	0/1												Sys 2 Remote Start/Stop (SP Unit)
<b>ANALOG READ ONLY POINTS</b>																					
11	LCHLT	A11	514	03.04	x10	ADF 8	°F		°C												Leaving Chilled Liquid Temp
12	RCHLT	A12	515	03.04	x10	ADF 9	°F		°C												Entering Chilled Liquid Temp
13	DAT	A13	516	03.04	x10	ADF 10	°F		°C												Discharge Air Temp (DAT Unit)
14	S1_SUCT_TEMP	A14	517	03.04	x10	ADF 11	°F		°C												Sys 1 Suction Temp (EEV, Cond Units, R-410a)
15	OAT	A15	518	03.04	x10	ADF 12	°F		°C												Ambient Air Temp
16	S1_SUCT_SH	A16	519	03.04	x10	ADF 13	°F (diff)		°C (diff)												Sys 1 Suction Superheat (EEV)
17	S1_RUN_TIME	A17	520	03.04	x10	ADF 14	None		None												Sys 1 Run Time in seconds
18	S1_SUCT_PR	A18	521	03.04	x10	ADF 15	PSI		BAR												Sys 1 Suction Pressure
19	S1_DSCH_PR	A19	522	03.04	x10	ADF 16	PSI		BAR												Sys 1 Discharge Pressure
20	S1_CIR_TEMP	A110	523	03.04	x10	ADF 17	°F		°C												Sys 1 Cooler Inlet Refrigerant Temp (R-407c)
21	S1_DEF_TEMP	A111	524	03.04	x10	ADF 18	°F		°C												Sys 1 Defrost Temperature (HP)
22	S1_EEV_OUT	A112	525	03.04	x10	ADF 19	%		%												Sys 1 EEV Output % (EEV)
23	S1_AR_TIMER	A113	526	03.04	x10	ADF 20	None		None												Sys 1 Anti-Recycle Timer in seconds
24	AC_TIMER	A114	527	03.04	x10	ADF 21	None		None												Anti-Coincident Timer in seconds
25	S2_SUCT_TEMP	A115	528	03.04	x10	ADF 22	°F		°C												Sys 2 Suction Temperature (EEV)
26	S2_RUN_TIME	A116	529	03.04	x10	ADF 23	None		None												Sys 2 Run Time in seconds
27	S2_SUCT_PR	A117	530	03.04	x10	ADF 24	PSI		BAR												Sys 2 Suction Pressure
28	S2_DSCH_PR	A118	531	03.04	x10	ADF 25	PSI		BAR												Sys 2 Discharge Pressure
29	S2_CIR_TEMP	A119	532	03.04	x10	ADF 26	°F		°C												Sys 2 Cooler Inlet Refrigerant Temp (R-407c)
30	S2_DEF_TEMP	A120	533	03.04	x10	ADF 27	°F		°C												Sys 2 Defrost Temperature (HP)
31	S2_SUCT_SH	A121	534	03.04	x10	ADF 28	°F (diff)		°C (diff)												Sys 2 Suction Superheat
32	S2_AR_TIMER	A122	535	03.04	x10	ADF 29	None		None												Sys 2 Anti-Recycle Timer
33	S2_EEV_OUT	A123	536	03.04	x10	ADF 30	%		%												Sys 2 EEV Output % (EEV)
34	NUM_COMPS	A124	537	03.04	x1	ADF 31	None		None												Number of Compressors





## Yorktalk 2 Communications

### **Received Data (Control Data)**

The unit receives eight data values from the E-Link Gateway. The first four are analog values and the last four are digital values. These eight data values are used as control parameters when in REMOTE mode. When the unit is in LOCAL mode, these eight values are ignored. If the unit receives no valid YorkTalk 2 transmission for 5 minutes it will revert back to all local control values. Table 18 on page 145 lists the control parameters. These values are found under feature 54 in the E-Link Gateway.

### **Transmitted Data**

After receiving a valid transmission from the E-Link Gateway, the unit will transmit either operational data or history buffer data depending on the “History Buffer Request” on ENG PAGE 10. Data must be transmitted for every page under feature 54. If there is no value to be sent to a particular page, a zero will be sent. *Table 18 on page 145* shows the data values and page listings for this unit.

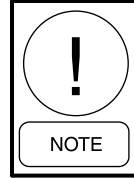

*The latest point map information is listed on the Johnson Controls Equipment Integration website [http://my.johnsoncontrols.com/portal/myportal/cg/prod/na/chiller\\_in](http://my.johnsoncontrols.com/portal/myportal/cg/prod/na/chiller_in)*

TABLE 18 - YORKTALK 2 COMMUNICATIONS DATA MAP

Item		Ref.	Version	Date	YORK P N	Checksum	Baud	COMMENTS	Micro Board: 031-02050/02550										
ENG PAGE REF	YORKTALK POINT TYPE	LON PROFILE NAME	LON SNVT TYPE	YORKTALK CHARACTER POSITION	N2 ADDRESS	POINT LIST CODE:	S = STANDARD	O = OPTIONAL	N = NOT AVAILABLE										
						POINT LIST DESCRIPTION			1	2	3	4	5	6	7	8	9	10	
P01	A. Control	mwYTS01p003	SNVT_count_f (51)		ADF 1	Setpoint	S		S	S	S	S	S	S					P03
P02	A. Control	mwYTS01p004	SNVT_count_f (51)		ADF 2	Load Limit Stage (0, 1, 2)	S		S	S	S	S	S	S					P04
P03	A. Control	mwYTS01p005	SNVT_count_f (51)		ADF 3	Heating Setpoint (HP and YCWL HP)	O		O	O	O	O	O	O					P05
P04	A. Control	mwYTS01p006	SNVT_count_f (51)		ADF 4	Mode (HP and YCWL HP only) (0=Panel, 1= Cooling, 2 = Heating)	O		O	O	O	O	O	O					P06
P05	D. Control	mwYTS01p007	SNVT_switch (95)		BD 1	Start/Stop Command	S		S	S	S	S	S	S					P07
P06	D. Control	mwYTS01p008	SNVT_switch (95)		BD 2														P08
P07	D. Control	mwYTS01p009	SNVT_switch (95)		BD 3														P09
P08	D. Control	mwYTS01p010	SNVT_switch (95)		BD 4	History Buffer Request	S		S	S	S	S	S	S					P10
P09	A. Monitor	mwYTS01p011	SNVT_count_f (51)	8 - 11	ADF 5	Leaving Chilled Liquid Temp	S		S	S	S	S	S	S					P11
P10	A. Monitor	mwYTS01p012	SNVT_count_f (51)	12 - 15	ADF 6	Return Chilled Liquid Temp	S		S	S	S	S	S	S					P12
P11	A. Monitor	mwYTS01p013	SNVT_count_f (51)	16 - 19	ADF 7	Leaving Hot Liquid Temp (R-410a) Heat Mode Only	O		O	O	O	O	O	O					P13
P12	A. Monitor	mwYTS01p014	SNVT_count_f (51)	20 - 23	ADF 8	Discharge Air Temp (Cond Unit) Return Hot Liquid Temp (410a- Heat Mod	S		S	S	S	S	S	S					P14
P13	A. Monitor	mwYTS01p015	SNVT_count_f (51)	24 - 27	ADF 9	Leaving Liquid Temp Hot (R-410a)	O		O	O	O	O	O	O					P15
P14	A. Monitor	mwYTS01p016	SNVT_count_f (51)	28 - 31	ADF 10	Ambient Air Temperature	S		S	S	S	S	S	S					P16
P15	A. Monitor	mwYTS01p017	SNVT_count_f (51)	32 - 35	ADF 11	Sys 1 Suction Superheat ( EEV only)	O		O	O	O	O	O	O					P17
P16	A. Monitor	mwYTS01p018	SNVT_count_f (51)	36 - 39	ADF 12	Sys 1 Run Time (seconds)	S		S	S	S	S	S	S					P18
P17	A. Monitor	mwYTS01p019	SNVT_count_f (51)	40 - 43	ADF 13	Sys 1 Suction Pressure	S		S	S	S	S	S	S					P19
P18	A. Monitor	mwYTS01p020	SNVT_count_f (51)	44 - 47	ADF 14	Sys 1 Discharge Pressure	S		S	S	S	S	S	S					P20
P19	A. Monitor	mwYTS01p021	SNVT_count_f (51)	48 - 51	ADF 15	Sys 1 Cooler Inlet Refrigerant Temperature(R-407c Only)	S		S	S	S	S	S	S					P21
P20	A. Monitor	mwYTS01p022	SNVT_count_f (51)	52 - 55	ADF 16														P22
P21	A. Monitor	mwYTS01p023	SNVT_count_f (51)	56 - 59	ADF 17	Sys 1 EEV Output % (EEV only)	O		O	O	O	O	O	O					P23
P22	A. Monitor	mwYTS01p024	SNVT_count_f (51)	60 - 63	ADF 18	Sys 1 Anti-Recycle Timer	S		S	S	S	S	S	S					P24
P23	A. Monitor	mwYTS01p025	SNVT_count_f (51)	64 - 67	ADF 19	Anti-Coincident Timer	O		O	O	O	O	O	O					P25
P24	A. Monitor	mwYTS01p026	SNVT_count_f (51)	68 - 71	ADF 20	Sys Suction Temp ( EEV only)	O		O	O	O	O	O	O					P26
P25	A. Monitor	mwYTS01p027	SNVT_count_f (51)	72 - 75	ADF 21	Sys 2 Run Time (seconds)	S		S	S	S	S	S	S					P27
P26	A. Monitor	mwYTS01p028	SNVT_count_f (51)	76 - 79	ADF 22	Sys 2 Suction Pressure	S		S	S	S	S	S	S					P28
P27	A. Monitor	mwYTS01p029	SNVT_count_f (51)	80 - 83	ADF 23	Sys 2 Discharge Pressure	S		S	S	S	S	S	S					P29
P28	A. Monitor	mwYTS01p030	SNVT_count_f (51)	84 - 87	ADF 24	Sys 2 Cooler Inlet Refrigerant Temperature (R-407c systems Only)	S		S	S	S	S	S	S					P30
P29	A. Monitor	mwYTS01p031	SNVT_count_f (51)	88 - 91	ADF 25	Sys 2 Defrost Temperature ( HP only)	O		O	O	O	O	O	O					P31
P30	A. Monitor	mwYTS01p032	SNVT_count_f (51)	92 - 95	ADF 26	Sys 2 Suction Superheat ( EEV only)	O		O	O	O	O	O	O					P32
P31	A. Monitor	mwYTS01p033	SNVT_count_f (51)	96 - 99	ADF 27	Sys 2 Anti-Recycle Timer	S		S	S	S	S	S	S					P33
P32	A. Monitor	mwYTS01p034	SNVT_count_f (51)	100 - 103	ADF 28	Sys 2 EEV Output % (EEV only)	O		O	O	O	O	O	O					P34
P33	A. Monitor	mwYTS01p035	SNVT_count_f (51)	104 - 107	ADF 29	Number of Compressors	S		S	S	S	S	S	S					P35
P34	D. Monitor	mwYTS01p036	SNVT_switch (95)	108	BD 5	Sys 1 Alarm	S		S	S	S	S	S	S					P36
P35	D. Monitor	mwYTS01p037	SNVT_switch (95)	109	BD 6	Sys 2 Alarm	S		S	S	S	S	S	S					P37
P36	D. Monitor	mwYTS01p038	SNVT_switch (95)	110	BD 7	Evaporator Heater Status	S		S	S	S	S	S	S					P38
P37	D. Monitor	mwYTS01p039	SNVT_switch (95)	111	BD 8	Evaporator Pump Status	S		S	S	S	S	S	S					P39
P38	D. Monitor	mwYTS01p040	SNVT_switch (95)	112	BD 9	Sys 1 Compressor 1 Run	S		S	S	S	S	S	S					P40
P39	D. Monitor	mwYTS01p041	SNVT_switch (95)	113	BD 10	Sys 2 Compressor 1 Run	S		S	S	S	S	S	S					P41
P40	D. Monitor	mwYTS01p042	SNVT_switch (95)	114	BD 11	Sys 1 Liquid Line Solenoid Valve	S		S	S	S	S	S	S					P42

Use ASCII page column for interfaces utilizing an ASCII XL Translator or MicroGateway to communicate to a chiller LINC





THIS PAGE INTENTIONALLY LEFT BLANK

## SECTION 8 – UNIT OPERATION

### Unit Operating Sequence

The operating sequence described below relates to operation on a hot water start after power has been applied, such as start-up commissioning. When a compressor starts, internal timers limit the minimum time before another compressor can start to 1 minute.

1. For the chiller system to run, the Flow Switch must be closed, any remote cycling contacts must be closed, the Daily Schedule must not be scheduling the chiller OFF, and temperature demand must be present.
2. When power is applied to the system, the microprocessor will start a 2 minute timer. This is the same timer that prevents an instantaneous start after a power failure.
3. At the end of the 2 minute timer, the microprocessor will check for cooling demand. If all conditions allow for start, a compressor on the lead system will start and the liquid line solenoid will open. Coincident with the start, the anti-coincident timer will be set and begin counting downward from “60” seconds to “0” seconds.

If the unit is programmed for Auto Lead/Lag, the system with the shortest average run-time of the compressors will be assigned as the “lead” system. A new lead/lag assignment is made whenever all systems shut down.

4. Several seconds after the compressor starts, that systems first condenser fan will be cycled ON (outdoor air temperature more than 25 °F (-4 °C) or discharge pressure). See *Standard Condenser Fan Control on page 154* for details concerning condenser fan cycling.
5. After 1 minute of compressor run time, the next compressor in sequence will start when a system has to load. Additional compressors will be started at 60 second intervals as needed to satisfy temperature setpoint.
6. If demand requires, the lag system will cycle ON with the same timing sequences as the lead system after the lead system has run for five minutes. See the section on Capacity Control for a detailed explanation of system and compressor staging.

7. As the load decreases below setpoint, the compressors will be shut down in sequence. This will occur at intervals of either 60, 30, or 20 seconds based on water temperature as compared to setpoint, and control mode. See *Leaving Chilled Liquid Control on page 150* for a detailed explanation.
8. When the last compressor in a “system” (two or three compressors per system), is to be cycled OFF, the system will initiate a pump-down. Each “system” has a pump-down feature upon shut-off. On a non-safety, non-unit switch shutdown, the LLSV will be turned OFF and the last compressor will be allowed to run until the suction pressure falls below the suction pressure cutout or for 180 seconds, whichever comes first.

### CAPACITY CONTROL

To initiate the start sequence of the chiller, all run permissive inputs must be satisfied (flow/remote start/stop switch), and no chiller or system faults exist.

The first phase of the start sequence is initiated by the Daily Schedule Start or any Remote Cycling Device. If the unit is shut down on the daily schedule, the chilled water pump contacts (Terminals 23 and 24 of XTBC2) will close to start the pump when the daily schedule start time has been reached. Once flow has been established and the flow switch closes, capacity control functions are initiated, if the remote cycling contacts wired in series with the flow switch are closed.

It should be noted that the chilled water pump contacts (Terminals 23 and 24 of XTBC2) are not required to be used to cycle the chilled water pump. However, in all cases the flow switch must be closed to allow unit operation.

The control system will evaluate the need for cooling by comparing the actual leaving or return chilled liquid temperature to the desired setpoint, and regulate the leaving or return chilled liquid temperature to meet that desired setpoint.

**SUCTION PRESSURE LIMIT CONTROLS**

The anticipatory controls are intended to prevent the unit from ever actually reaching a low-pressure cut-out. Loading is prevented, if the suction pressure drops below 1.15 x suction pressure cutout (15% below the cutout). Loading may reoccur after suction pressure rises above the unload point and a period of one minute elapses. This control is only operable if the optional suction pressure transducers are installed.

**DISCHARGE PRESSURE LIMIT CONTROLS**

The discharge pressure limit controls unload a system before it reaches a safety limit due to high load or dirty condenser coils. The microprocessor monitors discharge pressure and unloads a system, if fully loaded, by one compressor when discharge pressure exceeds the programmed cutout minus 10 PSIG (0.69 barg). Reloading will occur when the discharge pressure on the affected system drops to 85% of the unload pressure and 10 minutes have elapsed.

This control is only applicable if optional discharge pressure transducers are installed.

**LEAVING CHILLED LIQUID CONTROL**

The setpoint, when programmed for Leaving Chilled Liquid Control, is the temperature the unit will control to within plus or minus the (control) cooling range. The Setpoint High Limit is the Setpoint plus the Cooling Range. The Setpoint Low Limit is the Setpoint minus the Cooling Range. Figure 30 below should be used to aid in understanding the following description of Leaving Chilled Liquid Control.

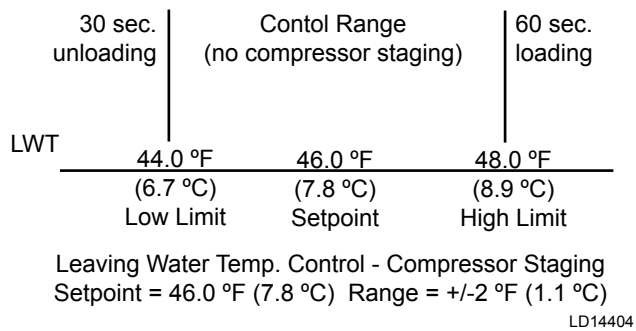

**FIGURE 38 - LEAVING WATER TEMPERATURE CONTROL EXAMPLE**

If the leaving chilled liquid temperature is above the Setpoint High Limit, the lead compressor on the lead system will be energized along with the liquid line solenoid. Upon energizing any compressor, the 60 second Anti-Coincidence timer will be initiated to prevent multiple compressors from turning ON.

If after 60 seconds of run-time the leaving chilled liquid temperature is still above the Setpoint High Limit, the next compressor in sequence will be energized. Additional compressors will be energized at a rate of once every 60 seconds if the chilled liquid temperature remains above the Setpoint High Limit and the chilled liquid temperature is dropping less than 3 °F/min. The lag system will not be allowed to start a compressor until the lead system has run for 5 minutes.

If the chilled liquid temperature falls below the Setpoint High Limit but is greater than the Setpoint Low Limit, loading and unloading do not occur. This area of control is called the control range.

If the chilled liquid temperature drops to between Setpoint Low Limit and 0.5 °F (0.28 °C) below the Setpoint Low Limit, unloading (a compressor turns OFF) occurs at a rate of 1 every 30 seconds. If the chilled liquid temperature falls to a value greater than 0.5 °F (0.28 °C) below the Setpoint Low Limit but not greater than 1.5 °F (0.83 °C) below the Setpoint Low Limit, unloading occurs at a rate of 20 seconds. If the chilled liquid temperature falls to a value greater than 1.5 °F (0.83 °C) below the Setpoint Low Limit, unloading occurs at a rate of 10 seconds. If the chilled liquid temperature falls below 1 °F above the low chilled liquid temperature cutout, unloading occurs at a rate of 10 seconds if it is greater than 10 seconds.

In water cooling mode on R-410A chillers, the minimum low limit of the control range will be 40.0°F. For leaving chilled liquid temperature setpoint and control range combinations that result in the low limit of the control range being below 40.0°F, the low limit will be reset to 40.0°F and the difference will be added to the high limit. This will result in a control range the same size as programmed but not allow the unit to run below 40.0°F. This control will not affect glycol chillers.

Hot gas, if present, will be the final step of capacity. Hot gas is energized when only a single compressor is running and LWT is less than SP. Hot gas is turned OFF as temperature rises when LWT is more than SP plus CR/2. If temperature remains below the setpoint low limit on the lowest step of capacity, the microprocessor will close the liquid line solenoid, after turning off hot gas, and pump the system down before turning off the last compressor in a system.

The leaving chilled liquid setpoint is programmable from 40 °F to 70 °F (4.4 °C to 21.1 °C) in water chilling mode and from 10 °F to 70 °F (-12.2 °C to 21.1 °C) in glycol chilling mode. In both modes, the cooling range can be from plus or minus 1.5 °F to plus or minus 2.5 °F (plus or minus .83 °C to 1.39 °C).leaving chilled liquid control.

**TABLE 19 - SAMPLE COMPRESSOR STAGING FOR RETURN WATER CONTROL**

COMPRESSOR STAGING FOR RETURN WATER CONTROL						
4 COMPRESSOR						
COOLING SETPOINT = 45 °F (7.2 °C) RANGE = 10 °F (5.6 °C)						
# OF COMP ON	0	* 1+HG	1	2	3	4
RWT	45 °F (7.2 °C)	46.25 °F (7.9 °C)	47.5 °F (8.6 °C)	50.0 °F (10.0 °C)	52.5 °F (11.4 °C)	55.0 °F (12.8 °C)

\*Unloading only

**LEAVING CHILLED LIQUID CONTROL  
OVERRIDE TO REDUCE CYCLING**

To avoid compressor cycling the microprocessor will adjust the setpoint upward temporarily. The last run time of the system will be saved. If the last run time was greater than 5 minutes, no action is to be taken. If the last run time for the lead system was less than 5 minutes, the microprocessor will increase the setpoint high limit according to the chart at right, with a maximum value allowed of 50 °F (see Figure 29 on page 152).

If adding the setpoint adjust value to the setpoint high limit causes the setpoint high limit to be greater than 50 °F, the setpoint high limit will be set to 50 °F, and the difference will be added to the setpoint low limit.

Once a system runs for greater than 5 minutes, the setpoint adjust will be set back to 0. This will occur while the system is still running.

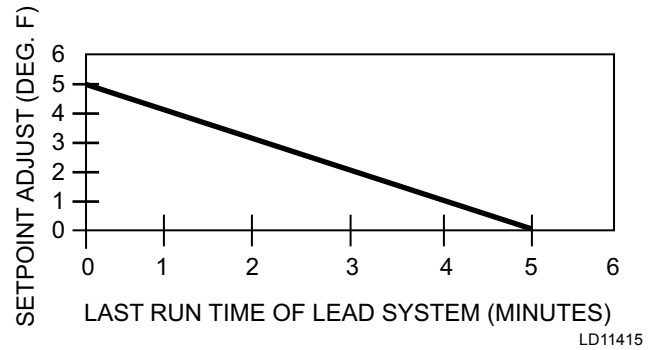

**FIGURE 39 - SETPOINT ADJUST**

**TABLE 20 - RETURN CHILLED LIQUID CONTROL FOR 4 COMPRESSORS (6 STEPS)**

*STEP	COMPRESSOR	COMPRESSOR ON POINT	COMPRESSOR OFF POINT
0	0	SETPOINT	SETPOINT
1	1 W/HGB	SP + CR/8 (Note 1)	SETPOINT
2	1 NO HGB	SP + CR/4	SP + CR/8
3	2	SP + 2*CR/4 (Note 2)	SP + CR/4
4	2	SP + 2*CR/4	SP + CR/4 (Note 3)
5	3	SP + 3*CR/4	SP + 2*CR/4
6	4	SP + CR	SP + 3*CR/4

**NOTES:**

- Step 1 is Hot Gas Bypass and is skipped when loading occurs. Hot Gas Bypass operation is inhibited during Pumpdown.
  - Step 3 is skipped when loading occurs.
  - Step 4 is skipped when unloading occurs.
- \* STEP can be viewed using the OPER DATA key and scrolling to COOLING DEMAND.

### LEAVING CHILLED LIQUID SYSTEM LEAD/LAG AND COMPRESSOR SEQUENCING

A Lead/Lag option may be selected to help equalize average run hours between systems with 2 refrigerant systems. This may be programmed under the OPTIONS key. Auto Lead/Lag allows automatic Lead/Lag of the two systems based on average run hours of the compressors in each system. Manual Lead/Lag selects specifically the sequence which the microprocessor starts systems.

On a hot water start, once a system starts, it will turn ON all compressors before the next system starts a compressor. The microprocessor will sequence compressors within each circuit to maximize individual compressor run time on individual compressors within a system to prevent short cycling.

Each compressor in a system will be assigned an arbitrary priority number 1, 2, or 1, 2, 3. The non-running compressor within a system with the lowest priority number will always be the next compressor to start. The running compressor with priority number 1 will always be the next to shut OFF. Whenever a compressor is shut OFF, the priority numbers of all compressors will be decreased by 1 with wrap-around. This control scheme assures the same compressor does not repeatedly cycle ON and OFF.

Once the second system starts a compressor on a 2 system chillers, the microprocessor will attempt to equally load each system as long as the system is not limiting or pumping down. Once this occurs, loading and unloading will alternate between systems, loading the lead system first or unloading the lag system first.

### RETURN CHILLED LIQUID CONTROL

**(Can be used on Dual System 4, 5 and 6 Comp Units Only)**

Return chilled liquid control is based on staging the compressors to match the cooling load. The chiller will be fully loaded when the return water temperature is equal to the Cooling Setpoint plus the Range. The chiller will be totally unloaded (all compressors OFF) when the return water temperature is equal to the Cooling Setpoint (See sample in Table 19 on page 151). At return water temperatures between the Cooling Setpoint and Cooling Setpoint plus Range, compressor loading and unloading will be determined by the formulas in Table 20 on page 151.

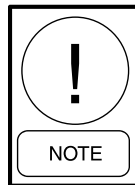

**Return Chilled Liquid Control MUST only be used when constant chilled liquid flow is ensured.**

**The range MUST always be programmed to equal the temperature drop across the evaporator when the chiller is “fully loaded”. Otherwise, chilled liquid temperature will over or under shoot. Variable flow must never be used in return chilled liquid mode.**

Normal loading will occur at intervals of 60 seconds according to the temperatures determined by the formulas. Unloading will occur at a rate of 30 seconds according to the temperatures determined in the formulas used to calculate the ON and OFF points for each step of capacity.

The return chilled liquid setpoint is programmable from 40 °F to 70 °F (4.4 °C to 21.1 °C) in water chilling mode and from 10 °F to 70 °F (-12.2 °C to 21.1 °C) in glycol chilling mode. In both modes, the cooling range can be from 4 °F to 20 °F (2.2° to 11.1 °C).

**TABLE 21 - LEAD/LAG RETURN CHILLED LIQUID CONTROL FOR 4 COMPRESSORS (6 STEPS)**

STEP	LEAD SYSTEM				LAG SYSTEM		
	COMP 1	COMP 2	-		COMP 1	COMP 2	-
0	OFF	OFF	-	SEE NOTE 1	OFF	OFF	-
1	ON + HG	OFF	-		OFF	OFF	-
2	ON	OFF	-		OFF	OFF	-
3	ON	OFF	-	SEE NOTE 2	ON	OFF	-
4	ON	ON	-	SEE NOTE 3	OFF	OFF	-
5	ON	ON	-		ON	OFF	-
6	ON	ON	-		ON	ON	-

- NOTES**
1. Step is Hot Gas Bypass and is skipped when loading occurs. Hot Gas Bypass operation is inhibited during pumpdown. For Leaving Chilled Liquid Control the Hot Gas Bypass solenoid is energized only when the lead compressor is running and the LWT < SP, the Hot Gas Bypass solenoid is turned off when the LWT more than SP + CR/2.
  2. Step 3 is skipped when loading occurs.
  3. Step 4 is skipped when unloading occurs.

As an example of compressor staging (See *Table 20 on page 151*), a chiller with six compressors using a Cooling Setpoint programmed for 45 °F (7.20 °C) and a Range Setpoint of 10 °F (5.56 °C). Using the formulas in *Table 20 on page 151*, the control range will be split up into six (seven including hot gas) segments, with the Control Range determining the separation between segments. Note also that the Cooling Setpoint is the point at which all compressors are OFF, and Cooling Setpoint plus Range is the point all compressors are ON. Specifically, if the return water temperature is 55 °F (12.8 °C), then all compressors will be ON, providing full capacity. At nominal gpm, this would provide approximately 45 °F (7.2 °C) leaving water temperature out of the evaporator.

If the return water temperature drops to 53.4 °F (11.9 °C), one compressor would cycle OFF leaving five compressors running. The compressors would continue to cycle OFF approximately every 1.7 °F (.94 °C), with the exception of hot gas bypass. Notice that the hot gas bypass would cycle ON when the return water temperature dropped to 46.25 °F (7.9 °C). At this point one compressor would be running with hot gas.

Should the return water temperature rise from this point to 46.7 °F (8.2 °C), the hot gas bypass would shut OFF, still leaving one compressor running. As the load increased, the compressors would stage ON every 1.7 °F (.94 °C).

Also note that *Table 20 on page 151* not only provides the formulas for the loading (ON POINT) and unloading (OFF POINT) of the system, the “STEP” is also shown in the table. The “STEP” is the increment in the sequence of the capacity control scheme that can be viewed under the OPER DATA key. See *Display/Print Keys on page 115* for specific information on the OPER DATA key.

### **RETURN CHILLED LIQUID SYSTEM LEAD/LAG AND COMPRESSOR SEQUENCING**

A Lead/Lag option may be selected to help equalize average run hours between systems with 2 refrigerant systems. This may be programmed under the OPTIONS key. Auto Lead/Lag of the 2 systems based on average run hours of the compressors in each system. Manual Lead/Lag selects specifically the sequence which the microprocessor starts the systems.

The microprocessor will sequence compressors load and unload systems according to *Table 21 on page 152*. The microprocessor will lead/lag compressors within each circuit to maximize individual compres-

sor run time for the purpose of lubrication. It will also prevent the same compressor from starting 2 times in a row. The microprocessor will not attempt to equalize run time on individual compressors within a system.

Each compressor in a system will be assigned an arbitrary number 1, or 2. The non-running compressor within a system with the lowest priority number will always be the next compressor to start. The running compressor with priority number 1 will always be the next compressor to shut OFF. Whenever a compressor is shut OFF, the priority numbers of all compressors in each system will be decreased by 1 with the wrap around. This control scheme assures the same compressor does not repeatedly cycle ON and OFF.

### **ANTI-RECYCLE TIMER**

The programmable anti-recycle timer assures that systems do not cycle. This timer is programmable under the PROGRAM key between 300 and 600 seconds. Whenever possible, to reduce cycling and motor heating, the anti-recycle timer should be adjusted to 600 seconds. The programmable anti-recycle timer starts the timer when the first compressor in a system starts. The timer begins to count down. If all of the compressors in a circuit cycle OFF, a compressor within the circuit will not be permitted to start until the anti-recycle timer has timed out. If the lead system has run for less than 5 minutes, 3 times in a row, the anti-recycle timer will be extended to 10 minutes.

### **ANTI-COINCIDENCE TIMER**

This timer is not present on single-system units. Two timing controls are present in software to assure compressors within a circuit or between systems, do not start simultaneously. The anti-coincidence timer assures there is at least a one minute delay between system starts on 2-circuit systems. This timer is NOT programmable. The load timers further assure that there is a minimum time between compressor starts within a system.

### **EVAPORATOR PUMP CONTROL AND YORK HYDRO KIT PUMP CONTROL**

The evaporator pump dry contacts (XTBC2 – Terminals 23 and 24) are energized when any of the following conditions are true:

1. Low Leaving Chilled Liquid Fault
2. Any compressor is running
3. Daily Schedule is ON, Unit Switch is ON and Remote Stop is closed

The pump will not run if the microprocessor panel has been powered up for less than 30 seconds or if the pump has run in the last 30 seconds to prevent pump motor overheating.

Whenever the option “YORK HYDRO KIT PUMPS = 1” is selected under the OPTIONS key, the pump control will be as described above. DO NOT SELECT the option “YORK HYDRO KIT PUMPS = 2” under the OPTIONS key. If a dual pump option is installed, the active pump is selected by the selector switch.

### EVAPORATOR HEATER CONTROL

The evaporator heater is controlled by ambient air temperature. When the ambient temperature drops below 40 °F (4.4 °C) the heater is turned ON. When the temperature rises above 45 °F (7.2 °C) the heater is turned OFF. An under voltage condition will keep the heater OFF until full voltage is restored to the system.

### PUMPDOWN CONTROL

Each system has a pump-down feature upon shut-off. Manual pumpdown from the keypad is not possible. On a non-safety, non-unit switch shutdown, all compressors but one in the system will be shut OFF. The LLSV will also be turned OFF. The final compressor will be allowed to run until the suction pressure falls below the cutout, or for 180 seconds, whichever comes first.

### STANDARD CONDENSER FAN CONTROL

Condenser fan operation must be programmed with the OPTIONS key under “Fan Control.” Condenser fan must be selected for Discharge Pressure only. Fan control by discharge pressure will work according to the tables on the following pages (see *Table 22 on page 156* and *Table 23 on page 157*). The fan control on pressure and fan differential off-pressure are programmable under the PROGRAM key. Standard fan control operates down to a temperature of 25° F.

The delay between turning ON and OFF fan stages is always fixed at 5 seconds.

When a fan stage is turned ON by pressure, the on pressure for the next stage is increased 20 PSIG and ramped back to the programmed on pressure over the next 20 seconds. Typically, standard ambient control on pressure should be programmed at 385 PSIG with a differential of 125 PSIG.

When a fan stage is turned OFF (programmed on pressure minus programmed differential), the off pressure for the next stage is decreased 20 PSIG and ramped back to the programmed off pressure minus the differential over the next 20 seconds.

Condenser fan locations are shown in *Figure 40 on page 155*. Detailed Standard Fan Control operation is shown in *Table 22 on page 156* and *Table 23 on page 157*.

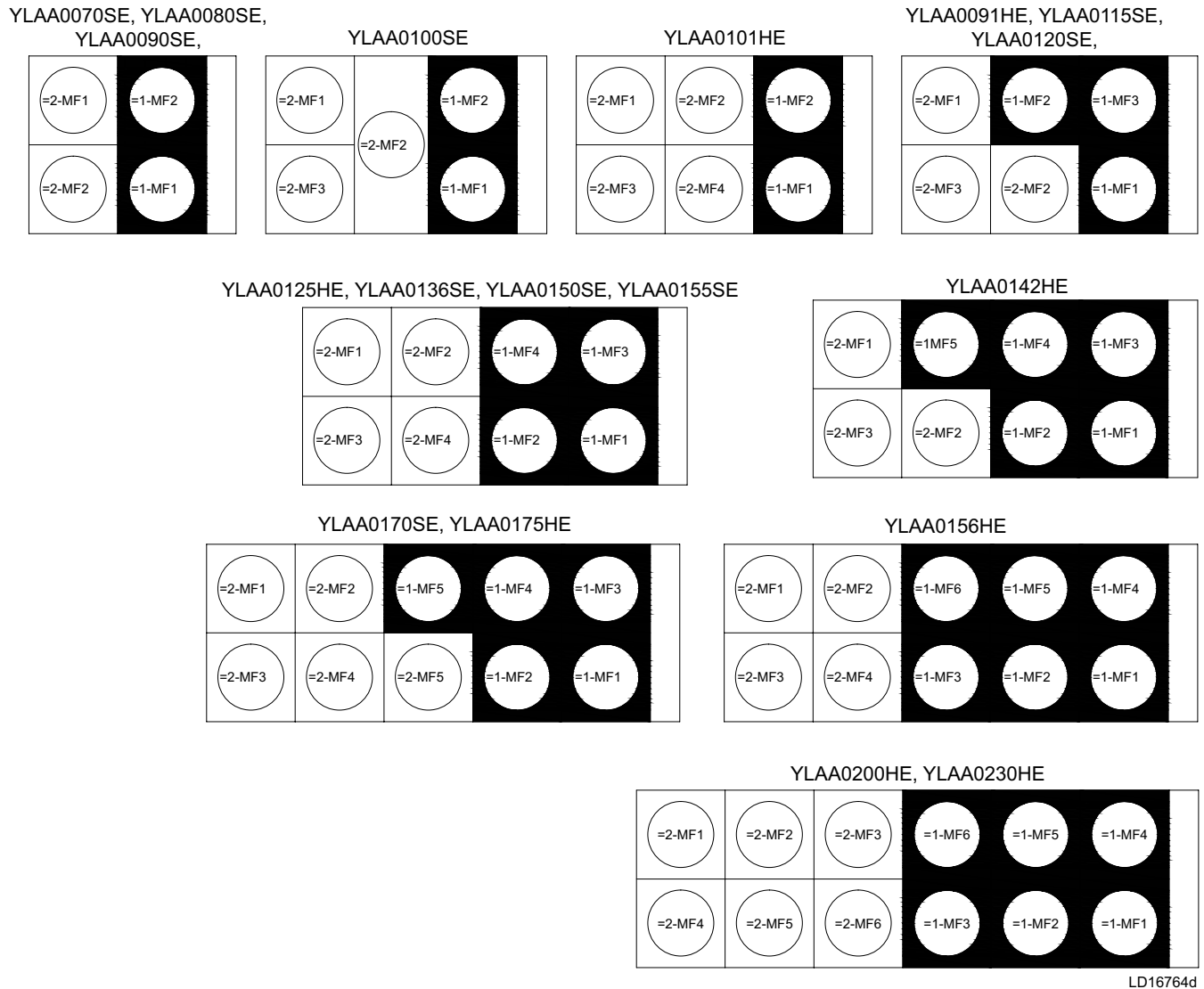

LD16764d

**FIGURE 40 - CONDENSER FAN LOCATIONS**

**TABLE 22 - YLAA STANDARD CONDENSER FAN CONTROL USING DISCHARGE PRESSURE ONLY (2, 3, OR 4 FANS PER SYSTEM)**

FAN STAGE	ON*	OFF**	IPUI I/O OUTPUT		FAN CONTACTOR		FAN #	
			SYS 1	SYS 2	SYS 1	SYS 2	SYS 1	SYS 2
1	DP > PROGRAMMED FAN CONTROL ON PRESSURE	DP < PROGRAMMED FAN CONTROL ON PRESSURE MINUS PROGRAMMED DIFFERENTIAL PRESSURE	7B7-8	TB10-8	1-KF1	2-KF1	1-MF1	2-MF2
2	DP > PROGRAMMED FAN CONTROL ON PRESSURE AND FAN STAGE 1 IS ENERGIZED	DP < PROGRAMMED FAN CONTROL ON PRESSURE MINUS PROGRAMMED DIFFERENTIAL PRESSURE AND FAN STAGE 1 IS ENERGIZED	TB7-8 and TB7-9	TB10-8 and TB10-9	1-KF1 and 1-KF2	2-KF1 and 2-KF2	1-MF1 and 1-MF2	2-MF1 and 2-MF2
3	DP > PROGRAMMED FAN CONTROL ON PRESSURE AND FAN STAGES 1 AND 2 ARE ENERGIZED	DP < PROGRAMMED FAN CONTROL ON PRESSURE MINUS PROGRAMMED DIFFERENTIAL PRESSURE AND FAN STAGES 1 AND 2 ARE ENERGIZED	TB7-8 and TB7-9 and TB7-10	TB10-8 and TB10-9 and TB10-10	1-KF1 and 1-KF2 and 1-KF3	2-KF1 and 2-KF2 and 2-KF3	3 FAN: 1-MF1 and 1-MF2 and 1-MF3 4 FAN: 1-MF1 and 1-MF2 and 1-MF3 and 1-MF4	3 FAN: 2-MF1 and 2-MF2 and 2-MF3 4 FAN: 2-MF1 and 2-MF2 and 2-MF3 and 2-MF4

\* When a fan stage is turned on, the pressure for the next stage is increased 20 PSIG and ramped back to the programmed on pressure over the next 20 seconds.

\*\* When a fan stage is turned off (Programmed ON pressure minus the differential), the OFF pressure for the next stage is decreased 20 PSIG and ramped back to the programmed OFF pressure minus the differential.

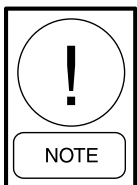

*The time delay (fan delay timer) between turning fan stages on and off is fixed at 5 seconds.*

**TABLE 23 - YLAA STANDARD CONDENSER FAN CONTROL USING DISCHARGE PRESSURE ONLY (5 OR 6 FANS PER SYSTEM)**

FAN STAGE	ON*	OFF**	IPUI I/O OUTPUT		FAN CONTACTOR		FAN #	
			SYS 1	SYS 2	SYS 1	SYS 2	SYS 1	SYS 2
1	DP > PROGRAMMED FAN CONTROL ON PRESSURE	DP < PROGRAMMED FAN CONTROL ON PRESSURE MINUS PROGRAMMED DIFFERENTIAL PRESSURE	TB7-8	TB10-8	1-KF1	2-KF1	1-MF1	2-MF1
2	DP > PROGRAMMED FAN CONTROL ON PRESSURE AND FAN STAGE 1 IS ENERGIZED	DP < PROGRAMMED FAN CONTROL ON PRESSURE MINUS PROGRAMMED DIFFERENTIAL PRESSURE AND FAN STAGE 1 IS ENERGIZED	TB7-8 and TB7-9	TB10-8 and TB10-9	1-KF1 and 1-KF2	2-KF1 and 2-KF2	1-MF1 and 1-MF2 and 1-MF3	2-MF1 and 2-MF2 and 2-MF3
3	DP > PROGRAMMED FAN CONTROL ON PRESSURE AND FAN STAGES 1 AND 2 ARE ENERGIZED	DP < PROGRAMMED FAN CONTROL ON PRESSURE MINUS PROGRAMMED DIFFERENTIAL PRESSURE AND FAN STAGES 1 AND 2 ARE ENERGIZED	TB7-8 and TB7-9 and TB7-10	TB10-8 and TB10-9 and TB10-10	1-KF1 and 1-KF2 and 1-KF3	2-KF1 and 2-KF2 and 2-KF3	5 FAN: 1-MF1 and 1-MF2 and 1-MF3 and 1-MF4 and 1-MF5 6 FAN: 1-MF1 and 1-MF2 and 1-MF3 and 1-MF4 and 1-MF5 and 1-MF6	5 FAN: 1-MF1 and 1-MF2 and 1-MF3 and 1-MF4 and 1-MF5 6 FAN: 1-MF1 and 1-MF2 and 1-MF3 and 1-MF4 and 1-MF5 and 1-MF6

\* When a fan stage is turned on, the pressure for the next stage is increased 20 PSIG and ramped back to the programmed on pressure over the next 20 seconds.  
 \*\* When a fan stage is turned off (Programmed ON pressure minus the differential), the OFF pressure for the next stage is decreased 20 PSIG and ramped back to the programmed OFF pressure minus the differential.

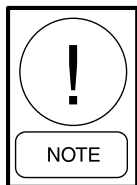

***The time delay (fan delay timer) between turning fan stages on and off is fixed at 5 seconds.***

## LOAD LIMITING

Load Limiting is a feature that prevents the unit from loading beyond the desired value. 2 and 4 compressor units can be load limited to 50%. This would allow only 1 compressor per system to run. 3 and 6 compressor units can be load limited to 33% or 66%. The 66% limit would allow up to 2 compressors per system to run, and the 33% limit would allow only 1 compressor per system to run. Five-compressor units may be load limited to 40% (1 compressor per system runs) or 80% (up to 2 compressors per system) are permitted to run. No other values of limiting are available.

There are two ways to load limit the unit. The first is through remote communication via an ISN. Load limit stages are sent through YORK Talk on pages 9 and 10 of feature 54. Page 9 is stage 1 load limit and page 10 is stage 2 load limit.

A second stage of load limiting the unit is accomplished by closing contacts connected to the Load Limit (XTBC1 – terminals 13-21) and PWM inputs (XTBC1 – terminals 13-20). Stage 1 of load limiting involves closing the Load Limit input. Stage 2 of load limiting involves closing both the Load Limit and PWM inputs. The first stage of limiting is either 80%, 66% or 50%, depending on the number of compressors on the unit. The second stage of limiting is either 40% or 33% and is only available on 3, 5 and 6 compressor units. *Table 24 on page 158* shows the load limiting permitted for the various numbers of compressors.

**TABLE 24 - COMPRESSOR OPERATION LOAD LIMITING**

COMPRESSORS IN UNIT	STAGE 1	STAGE 2
2	50%	-
3	66%	33%
4	50%	-
5	80%	40%
6	66%	33%

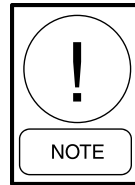

***Simultaneous operation of Remote Load Limiting and EMS-PWM Temperature Reset (described on following pages) cannot occur.***

## COMPRESSOR RUN STATUS

Compressor run status is indicated by closure of contacts at XTBC2 – Terminals 25 to 26 for system 1 and XTBC2 – Terminals 27 to 28 for system 2.

## ALARM STATUS

System or unit shutdown is indicated by normally-open alarm contacts opening whenever the unit shuts down on a unit fault, locks out on a system fault, or experiences a loss of power to the chiller electronics. System 1 alarm contacts are located at XTBC2 – Terminals 29 to 30. System 2 alarm contacts are located at XTBC2 – Terminals 31 to 32. The alarm contacts will close when conditions allow the unit to operate, or the fault is reset during a loss of power, the contacts will remain open until power is reapplied and no fault conditions exist.

## REMOTE BAS/EMS TEMPERATURE RESET USING A VOLTAGE OR CURRENT SIGNAL

The Remote Reset Option allows the Control Center of the unit to reset the chilled liquid setpoint using a 0 to 10VDC input, or a 4 to 20mA input connected to XTBC1 Terminals A- and A+. Whenever a reset is called for, the change may be noted by pressing the COOLING SETPOINTS key twice. The new value will be displayed as “REM SETP = XXX °F.”

If a 0 to 10VDC signal is supplied, it is applied to Terminals A+ and A-, and jumper JP1 on the I/O board must be inserted between pins 2 and 3. To calculate the reset chilled liquid setpoint for values between 0VDC and 10VDC use the following formula:

$$\text{Setpoint} = \text{Local Chilled Liquid Setpoint} + \text{°Reset}$$

$$\text{°Reset} = \frac{(\text{DC voltage signal}) \times (\text{*Max Reset Value})}{10}$$

Example:

Local Chilled Liquid Setpoint = 45 °F (7.22 °C)

\*Max Reset Value = 20 °F (11.11 °C)

Input Signal = 6VDC

(English)

$$\text{°Reset} = \frac{6\text{VDC} \times 20 \text{ °F}}{10} = 12 \text{ °F Reset}$$

New Setpoint = 45 °F + 12 °F = 57 °F

(Metric)

$$\text{°Reset} = \frac{6\text{VDC} \times 11.11 \text{ °C}}{10} = 6.67 \text{ °C Reset}$$

New Setpoint = 7.22 °C + 6.67 °C = 13.89 °C

\* Max Reset Value is the “Max EMS-PWM Remote Temp. Reset” setpoint value described in *Remote Setpoint Control on page 125* under “Cooling Setpoints”. Programmable values are from 2 °F to 40 °F (1.11 °C to 11.11 °C).

If a 4 to 20mA signal is supplied, it is applied to Terminals A+ and A- and jumper JP1 on the I/O board must be installed between pin 1 and 2. To calculate the chilled liquid setpoint for values between 4mA and 20 mA use the following formula:

$$\text{Setpoint} = \text{Local Chilled Liquid Setpoint} + \text{°Reset}$$

$$\text{°Reset} = \frac{(\text{mA signal} - 4) \times (\text{*Max Reset Value})}{16}$$

Example:

Local Chilled Liquid Setpoint = 45° (7.22 °C)

\*Max Reset Value = 10 °F (5.56 °C)

Input Signal = 12 mA

(English)

$$\text{°Reset} = \frac{8\text{mA} \times 10 \text{ °F}}{16} = 5 \text{ °F Reset}$$

Setpoint = 45 °F + 5 °F = 50 °F

(Metric)

$$\text{°Reset} = \frac{8\text{mA} \times 5.56 \text{ °C}}{16} = 2.78 \text{ °C Reset}$$

Setpoint = 7.22 °C + 2.78 °C = 10.0 °C

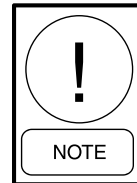

***A 240 to 24 Volt Ratio Transformer (T3) is used to derive nominal 12 volt output from the 120 volt supply.***

THIS PAGE INTENTIONALLY LEFT BLANK

## SECTION 9 – SERVICE AND TROUBLESHOOTING

### CLEARING HISTORY BUFFERS

The history buffers may be cleared by pressing the HISTORY key and then repeatedly pressing the UP arrow key until you scroll past the last history buffer choice. The following message will be displayed:

```
INITIALIZE HISTORY
ENTER = YES
```

Pressing the ENTER/ADV key at this display will cause the history buffers to be cleared. Pressing any other key will cancel the operation.

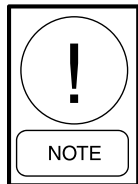

**DO NOT CLEAR BUFFERS. Important information may be lost. Contact factory service.**

### SERVICE MODE

Service Mode is a mode that allows the user to enable or disable all of the outputs (except compressors) on the unit, change chiller configuration setup parameters and view all the inputs to the microboard.

To enter Service Mode, turn the Unit Switch OFF and press the following keys in the sequence shown:

- PROGRAM
- UP ARROW
- UP ARROW
- DOWN ARROW
- DOWN ARROW
- ENTER

Service Mode will time out after 30 minutes and return to normal control mode, if the panel is accidentally left in this mode. Otherwise, turning the unit switch ON will take the panel out of Service Mode.

### SERVICE MODE – OUTPUTS

After pressing the key sequence as described, the control will enter Service Mode permitting the outputs (except compressors), operating hours, refrigerant type, expansion valve type, and start/hour counters to be viewed/modified. The ENTER/ADV key is used to advance through the outputs. Using the ↑ and ↓ (UP/DOWN) arrow keys will turn the respective digital output ON/OFF or modify the value.

Following is the order of outputs that will appear as the ENTER/ADV key is pressed:

```
SYS 1 COMP 1 STATUS TB7-2 IS:
  SYS 1 LLSV STATUS TB7-3 IS:
SYS 1 COMP 2 STATUS TB7-4 IS:
SYS 1 COMP 3 STATUS TB7-5 IS:
  SYS 1 HGBP STATUS TB7-7 IS:
SYS 2 COMP 1 STATUS TB10-2 IS:
  SYS 2 LLSV STATUS TB10-3 IS:
SYS 2 COMP 2 STATUS TB10-4 IS:
SYS 2 COMP 3 STATUS TB10-5 IS:
  SYS 1 FAN OUTPUT 1 TB7-8 IS:
  SYS 1 FAN OUTPUT 2 TB7-9 IS:
  SYS 1 FAN OUTPUT 3 TB7-10 IS:
  SYS 2 FAN OUTPUT 1 TB10-8 IS:
  SYS 2 FAN OUTPUT 2 TB10-9 IS:
  SYS 2 FAN OUTPUT 3 TB10-10 IS:
EVAP HEATER STATUS TB8-2 IS:
SYS 1 ALARM STATUS TB8-3 IS:
SYS 2 ALARM STATUS TB9-2 IS:
EVAP PUMP STATUS TB8-6,7 IS:
SYS 2 HGBV STATUS TB10-7 IS:
  SPARE DO TB8-4 IS:
  SPARE DO TB8-5 IS:
  SPARE DO TB8-8, 9 IS:
  SPARE DO TB9-4 IS:
SYS 1 EEV OUTPUT TB5-1, 2 = XXX%
SYS 2 EEV OUTPUT TB6-1, 2 = XXX%
SYS 1 COND FAN SPEED J15-1,5 = XXX%
SYS 2 COND FAN SPEED J15-2,6 = XXX%
  SPARE AO J15-3,7 = XXX%
  SPARE AO J15-4,8 = XXX%
DATA LOGGING MODE 1 = ON, 0 = OFF
DATA LOGGING TIMER X SECS
SOFT START (disabled)
REFRIGERANT TYPE (R-410A only)
EXPANSION VALVE TYPE (Thermostatic Only)
REMOTE TEMP RESET OPTION =
REMOTE INPUT SERVICE TIME =
“NORTH AMERICAN FEATURE SET ENABLED”
HYDRO PUMP SELECTION
EVAP PUMP TOTAL RUN HOURS
  SYS 1 HOURS
  SYS 2 HOURS
  SYS 1 STARTS
  SYS 2 STARTS
```

Each display will also show the output connection on the microboard for the respective output status shown. For example:

**S Y S 1 L L S V S T A T U S**  
**T B 1 0 - 3 I S O F F**

This display indicates that the system 1 liquid line solenoid valve is OFF, and the output connection from the microboard is coming from terminal block 10 – pin 3.

Pressing the ↑ (UP) arrow key will energize the liquid line solenoid valve and OFF will change to ON in the display as the LLSV is energized. Energizing and de-energizing outputs may be useful during troubleshooting.

### SERVICE MODE – CHILLER CONFIGURATION

After the Outputs are displayed, the next group of displays relate to chiller configuration and start/hour counters. Data logging, soft start, refrigerant type, pump control selection and expansion valve type all must be programmed to match actual chiller configuration.



*Soft start (disabled), Refrigerant Type (R-410A), and Expansion Valve Type (Thermostatic), and North American Feature (Enabled) MUST be properly programmed or damage to compressors and other system components may result*

Following is a list of chiller configuration selections, in order of appearance:

DATA LOGGING MODE = : DO NOT MODIFY  
DATA LOGGING TIMER = : DO NOT MODIFY  
SOFT START  
REFRIGERANT TYPE  
EXPANSION VALVE TYPE  
REMOTE TEMP RESET OPTION  
REMOTE INPUT SERVICE TIME  
FEATURE SET  
PUMP CONTROL SELECTION  
SYS 1 HOURS  
SYS 2 HOURS  
SYS 1 STARTS  
SYS 2 STARTS

The last displays shown on the above list are for the accumulated run and start timers for each system. All values can also be changed using the ↑ (UP) and ↓ (Down) arrow keys, but under normal circumstances would not be required or advised. After the last start display, the microprocessor will display the first programmable value under the PROGRAM key.

### SERVICE MODE – ANALOG AND DIGITAL INPUTS

After entering Service Mode (PROGRAM ↑↑ ↓↓), all digital and analog inputs to the microboard can be viewed by pressing the OPER DATA key. After pressing the OPER DATA key, the ↑ (UP) arrow and ↓ (DOWN) arrow keys are used to scroll through the analog and digital inputs.

Following is the order of analog and digital inputs that will appear when sequenced with the ↓ (Down) arrow key:

(analog inputs)  
SYS 1 SUCT PRESSURE  
UNIT TYPE  
SYS 1 \*DISCH PRESSURE  
SYS 1\*\* SUCTION TEMP.  
SYS 2\*\* SUCTION TEMP.  
AMBIENT AIR TEMP.  
LEAVING LIQUID TEMP.  
RETURN LIQUID TEMP.  
SYS 2 SUCTION PRESSURE  
SYS 2 SPARE  
SYS 2 \*DISCH PRESSURE  
SYS 1 MTR VOLTS  
SYS 2 MTR VOLTS  
(digital inputs)  
PWM TEMP RESET INPUT  
LOAD LIMIT INPUT  
FLOW SW / REM START  
SPARE  
SINGLE SYSTEM SELECT  
SYS 1 MP / HPCO INPUT  
SYS 2 MP / HPCO INPUT

\* The discharge pressure transducer is optional on some models.

\*\* The suction temp. sensor is on EEV units only.

The analog inputs will display the input connection, the temperature or pressure, and corresponding input voltage such as:

**S Y S 1 S U C T P R J 7 - 1 0**  
**2 . 1 V D C = 8 1 P S I G**

This example indicates that the system 1 suction pressure input is connected to plug 7 – pin 10 (J7-10) on the I/O board. It indicates that the voltage is 2.1VDC which corresponds to 81 PSIG (5.6 bars) suction pressure.

The digital inputs will display the input connection and ON/OFF status such as:

**F L O W S W / R E M S T A R T  
J 1 3 - 5 I S O N**

This indicates that the flow switch/remote start input is connected to plug 13- pin 5 (J13-5) on the microboard, and is ON (ON = +30VDC unregulated input, OFF = 0VDC input on digital inputs).

**CONTROL INPUTS/OUTPUTS**

Table 25 through Table 28 on page 163 are a quick reference list providing the connection points and a description of the inputs and outputs respectively. All input and output connections pertain to the connections at the microboard.

**TABLE 25 - I/O DIGITAL INPUTS**

<b>J13-2</b>	Unit ON/OFF Switch
<b>J13-3</b>	Load Limit Stage 2 on 3, 5 & 6 Comp. Units
<b>J13-4</b>	Load Limit Stage 1
<b>J13-5</b>	Flow Switch and Remote Start/Stop
<b>J13-6</b>	Spare
<b>J13-7</b>	Single System Select (Jumper = Single Sys, No Jumper = Two Sys)
<b>J13-8</b>	CR1 (Sys 1 Motor Protector/High Pressure Cutout)
<b>J13-10</b>	CR2 (Sys 2 Motor Protector/High Pressure Cutout)

**TABLE 26 - I/O DIGITAL OUTPUTS**

<b>TB7-2</b>	SYS 1 Compressor 1
<b>TB7-3</b>	SYS 1 Liquid Line Solenoid Valve
<b>TB7-4</b>	SYS 1 Compressor 2
<b>TB7-5</b>	SYS 1 Compressor 3
<b>TB7-7</b>	SYS 1 Hot Gas Bypass Valve
<b>TB10-2</b>	SYS 2 Compressor 1
<b>TB10-3</b>	SYS 2 Liquid Line Solenoid Valve
<b>TB10-4</b>	SYS 2 Compressor 2
<b>TB10-5</b>	SYS 2 Compressor 3
<b>TB7-8</b>	SYS 1 Condenser Fan Output 1
<b>TB7-9</b>	SYS 1 Condenser Fan Output 2
<b>TB7-10</b>	SYS 1 Condenser Fan Output 3
<b>TB10-8</b>	SYS 2 Condenser Fan Output 1
<b>TB10-9</b>	SYS 2 Condenser Fan Output 2
<b>TB10-10</b>	SYS 2 Condenser Fan Output 3
<b>TB8-2</b>	Evaporator Heater
<b>TB8-3</b>	SYS 1 Alarm
<b>TB9-2</b>	SYS 2 Alarm
<b>TB8-6 &amp; 7</b>	Evaporator Pump Starter
<b>TB10-7</b>	SYS 2 Hot Gas Bypass Valve

**TABLE 27 - I/O ANALOG INPUTS**

<b>J7-10</b>	SYS 1 Suction Transducer -or- SYS 1 Low Pressure Switch
<b>J11-12</b>	Unit Type: Chiller = NO Jumper J11-12 to +24 VDC YCUL Condensing Unit = Jumper J11-12 to +24 VDC (Do NOT Use)
<b>J7-11</b>	SYS 1 Discharge Pressure Transducer (Optional)
<b>J6-9</b>	Ambient Air Temp. Sensor
<b>J6-7</b>	Leaving Chilled Liquid Temp. Sensor
<b>J6-8</b>	Return Chilled Liquid Temp. Sensor
<b>J9-10</b>	SYS 2 Suction Pressure Transducer -or- SYS 2 Low Pressure Switch
<b>J9-11</b>	SYS 2 Discharge Pressure Transducer (Optional)
<b>J7-12</b>	Unit/SYS 1 Voltage
<b>J9-12</b>	SYS 2 Voltage
<b>J11-11</b>	Remote Temperature Reset

**TABLE 28 - I/O ANALOG OUTPUTS**

<b>N/A</b>	Not Applicable
------------	----------------

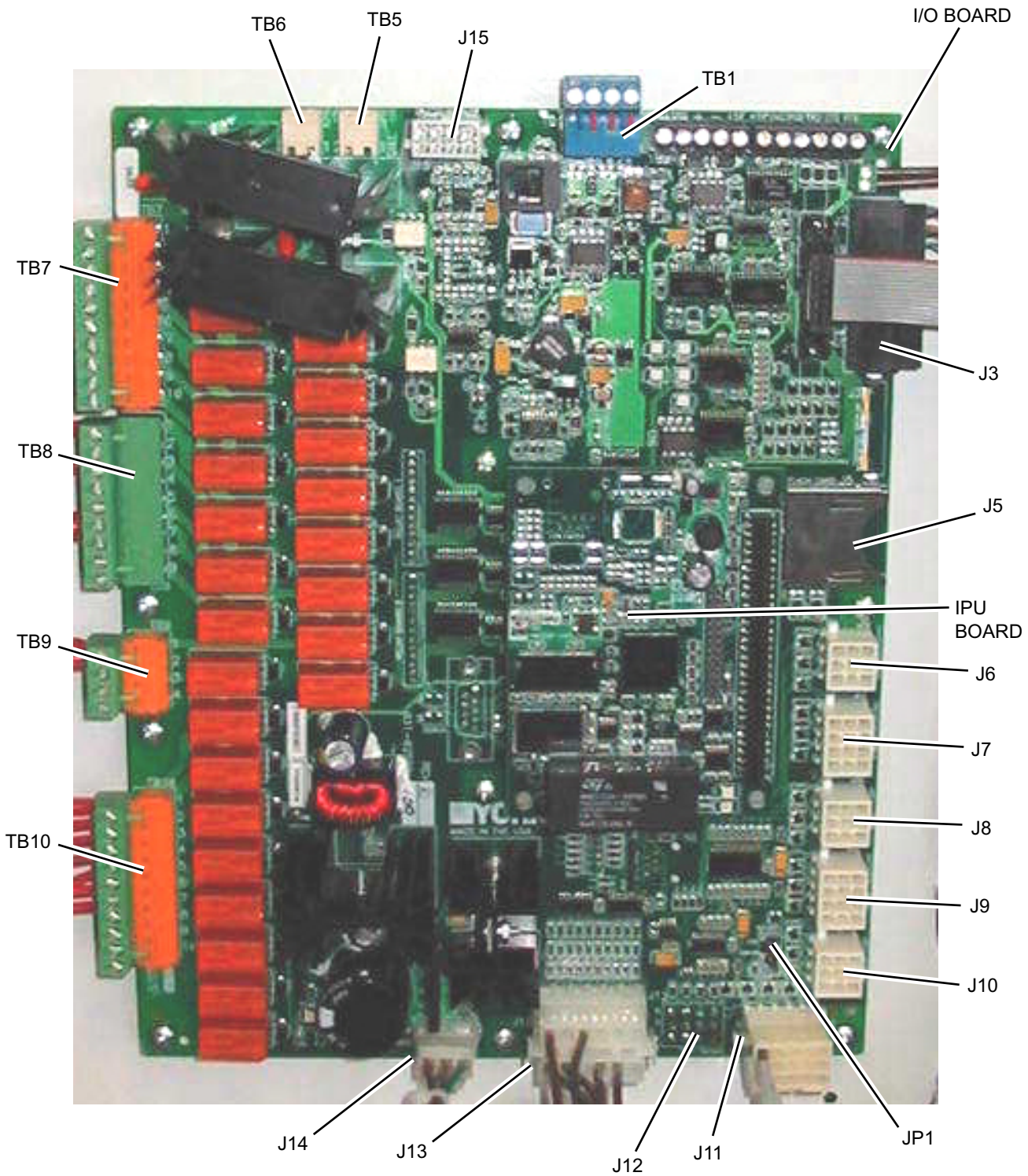

LD12721

FIGURE 41 - MICROBOARD LAYOUT

## CHECKING INPUTS AND OUTPUTS

### Digital Inputs

See the unit wiring diagram. All digital inputs are connected to J13-1 of the I/O board. The term “digital” refers to two states – either ON or OFF. As an example, when the flow switch is closed, 30VDC will be applied to J13, pin 5 (J13-5) of the I/O board. If the flow switch is open, 0VDC will then be present at J13-5.

Pin 1 of J13 is an unregulated 30VDC source used to supply the DC voltage to the various user contacts, unit switch, flow switch, etc. This DC source is factory wired to XTBC1, Terminal 13. Any switch or contact used as a digital input would be connected to this terminal, with the other end connecting to its respective digital input on the microboard. Any time a switch or contact is closed, 30VDC would be applied to that particular digital input. Any time a switch or contact is open, 0VDC would be applied to that particular digital input.

Typically, voltages of 24 to 36VDC could be measured for the DC voltage on the digital inputs. This voltage is in reference to ground. The unit case should be sufficient as a reference point when measuring digital input voltages.

### Analog Inputs – Temperature

See the unit wiring diagram. Temperature inputs are connected to the microboard on plug J6. These analog inputs represent varying DC signals corresponding to varying temperatures. All voltages are in reference to the unit case (ground). Following are the connections for the temperature sensing inputs.

### Outside Air Sensor

J6-6 = +5VDC regulated supply to sensor.

J6-9 = VDC input signal to the microboard.  
 See *Table 29 on page 165* for voltage readings that correspond to specific outdoor temperatures.

J6-3 = drain (shield connection = 0VDC) return

**TABLE 29 - OUTDOOR AIR SENSOR  
 TEMPERATURE/VOLTAGE/  
 CORRELATION**

TEMP °F	VOLTAGE (SIGNAL INPUT TO RETURN)	TEMP °C
0	0.7	-18
5	0.8	-15
10	0.9	-12
15	1.0	-9
20	1.1	-7
25	1.2	-4
30	1.4	-1
35	1.5	2
40	1.7	4
45	1.8	7
50	2.0	10
55	2.2	13
60	2.3	16
65	2.5	18
70	2.6	21
75	2.8	24
80	2.9	27
85	3.1	29
90	3.2	32
95	3.4	35
100	3.5	38
105	3.6	41
110	3.7	43
115	3.8	46
120	3.9	49
125	4.0	52
130	4.1	54

**TABLE 30 - ENTERING/LEAVING CHILLED LIQUID  
TEMP. SENSOR, TEMPERATURE/  
VOLTAGE CORRELATION**

TEMP °F	VOLTAGE (SIGNAL INPUT TO RETURN)	TEMP °C
10	1.33	-12
12	1.39	-11
14	1.46	-10
16	1.51	-9
18	1.58	-8
20	1.65	-7
22	1.71	-6
24	1.78	-4
26	1.85	-3
28	1.91	-2
30	1.98	-1
32	2.05	0
34	2.12	1
36	2.19	2
38	2.26	3
40	2.33	4
42	2.40	6
44	2.47	7
46	2.53	8
48	2.60	9
50	2.65	10
52	2.73	11
54	2.80	12
56	2.86	13
58	2.92	14
60	2.98	16
62	3.05	17
64	3.11	18
66	3.17	19
68	3.23	20
70	3.29	21
72	3.34	22
74	3.39	23
76	3.45	24
78	3.5	26
80	3.54	27

**Liquid and Refrigerant Sensor Test Points***(See Table 30 on page 166)***Entering Chilled Liquid Sensor**

J6-5 = +5VDC regulated supply to sensor.

J6-8 = VDC input signal to the I/O board. See *Table 30 on page 166* for voltage readings that correspond to specific liquid temperatures.

J6-2 = drain (shield connection = 0VDC) Return

**Leaving Chilled Liquid Temperature Sensor**

J6-4 = +5VDC regulated supply to sensor.

J6-7 = VDC input signal to the microboard. See *Table 30 on page 166* for voltage readings that correspond to specific liquid temperatures.

J6-1 = drain (shield connection = 0VDC) return

**Analog Inputs – Pressure**

See the unit wiring diagram. Pressure inputs are connected to the microboard on plugs J7 and J9. These analog inputs represent varying DC signals corresponding to varying pressures. All voltages are in reference to the unit case (ground).

System 1 discharge and suction pressures will be connected to J7 of the microboard. System 2 discharge and suction pressure transducers will be connected to J9 of the microboard.

The discharge transducers are optional on all units. If the discharge transducers are not installed, no connections are made to the microboard and the discharge pressure readout on the display would be zero.

The suction pressure transducers are standard on all YLAA's. The suction pressure transducers have a range of 0 to 400 PSIG. The output will be linear from 0.5VDC to 4.5VDC over the 400 PSIG (27.5 barg) range.

The discharge transducers have a range from 0 to 650 PSIG. The output will be linear from 0.5VDC to 4.5VDC over the 600 PSIG (41.25 barg) range. Following is the formula that can be used to verify the voltage output of the transducer. All voltage reading are in reference to ground (unit case).

**TABLE 31 - PRESSURE TRANSDUCERS**

0-400 PSIG SUCTION PRESSURE TRANSDUCER		0-600 PSIG DISCHARGE PRESSURE TRANSDUCER	
PRESSURE PSIG	VOLTAGE VDC	PRESSURE PSIG	VOLTAGE VDC
0	0.5	0	0.5
50	1.0	75	1.0
100	1.5	150	1.5
150	2.0	225	2.0
200	2.5	300	2.5
250	3.0	375	3.0
300	3.5	450	3.5
350	4.0	525	4.0
400	4.5	600	4.5

RED WIRE = 5V, BLACK WIRE = 0V, WHITE/GREEN WIRE = SIGNAL

**TEST POINTS:**

Suction Pressure:

System 1: .....Microboard J7-10 to J7-9

System 2: .....Microboard J9-10 to J9-9

Discharge Pressure:

System 1: .....Microboard J7-11 to J7-7

System 2: .....Microboard J9-11 to J9-7

$$V = (\text{Pressure in PSIG} \times .01) + .5$$

or

$$V = (\text{Pressure in BARG} \times .145) + .5$$

where V = DC voltage output

Pressure = pressure sensed by transducer

The I/O board connections for the Discharge Transducers are as follows.

**System 1 Discharge Transducer**

J7-6 = +5VDC regulated supply to transducer.

J7-11 = VDC input signal to the microboard. See the formula above for voltage readings that correspond to specific discharge pressures.

J7-7 = +5VDC return

J7-2 = drain (shield connection = 0VDC)

**System 2 Discharge Transducer**

J9-6 = +5VDC regulated supply to transducer.

J9-11 = VDC input signal to the microboard. See the formula above for voltage readings that correspond to specific discharge pressures.

J9-7 = +5VDC return

J9-2 = drain (shield connection = 0VDC)

The suction transducers have a range from 0 to 400 PSIG (27.5 barg). The output will be linear from 0.5VDC to 4.5VDC over the 400 PSIG (27.5 barg) range. Following is a formula that can be used to verify the voltage output of the transducer. All voltage readings are in reference to ground (unit case).

$$V = (\text{Pressure in PSIG} \times .02) + .5$$

or

$$V = (\text{Pressure in barg} \times .29) + .5$$

where V = DC voltage input to microprocessor

Pressure = pressure sensed by transducer

Following are the I/O board connections for the Suction Transducer.

**System 1 Suction Transducer**

J7-5 = +5VDC regulated supply to transducer.

J7-10 = VDC input signal to the microboard. See the formula above for voltage readings that correspond to specific suction pressures.

J7-9 = +5VDC return.

J7-1 = drain (shield connection = 0VDC).

**System 2 Suction Transducer**

J9-5 = +5VDC regulated supply to transducer.

J9-10 = VDC input signal to the microboard. See the formula above for voltage readings that correspond to specific suction pressures.

J7-9 = +5VDC return.

J7-11 = drain (shield connection = 0VDC).

**Digital Outputs**

See the unit wiring diagram and *Figure 42 on page 168*. The digital outputs are located on TB7, TB8, and TB9 and TB-10 of the microboard. All outputs are 120VAC with the exception of TB8-6 to TB8-7 which are the contacts that can be used for a remote evaporator pump start signal. The voltage applied to either of these terminals would be determined by field wiring.

Each output is controlled by the microprocessor by switching 120VAC to the respective output connection energizing contactors, evaporator heater, and solenoids according to the operating sequence.

120VAC is supplied to the I/O board via connections at TB7-1, TB7-6, TB10-1, TB10-6, TB8-1 and TB9-1. Figure 34 illustrates the relay contact architecture on the microboard.

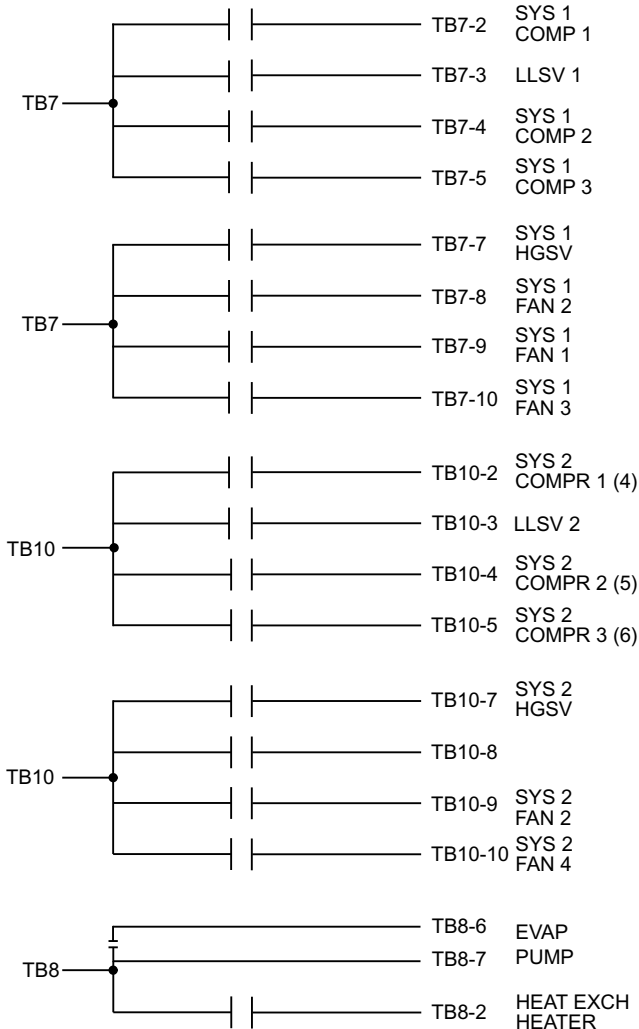

LD12722

**FIGURE 42 - I/O BOARD RELAY CONTACT ARCHITECTURE**

## OPTIONAL PRINTER INSTALLATION

The micro panel is capable of supplying a printout of chiller conditions or fault shutdown information at any given time. This allows operator and service personnel to obtain data and system status with the touch of the keypad. In addition to manual print selection, the micro panel will provide an automatic printout whenever a fault occurs. Detailed explanation of the print function is given under *Print Key on page 118*.

Johnson Controls recommends the field tested WEIGH-TRONIX model 1220 printer (or former IMP 24). This is a compact low cost printer that is ideal for service work and data logging.

The WEIGH-TRONIX printer can be obtained by contacting WEIGH-TRONIX for purchase information at:

WEIGH-TRONIX

2320 Airport Blvd.

Santa Rosa, CA 95402

Phone: 1-800-982-6622 or 1-707-527-5555

(International Orders Only)

The part number for the printer that is packaged specifically for YORK is P/N 950915576. The cable to connect the printer can either be locally assembled from the parts listed, or ordered directly from WEIGH-TRONIX under part number 287-040018.

### Parts

The following parts are required:

1. WEIGH-TRONIX model 1220 printer.
2. Desk top calculator paper, 2.25" (5.7cm) wide.
3. Twisted Pair Shielded Cable (minimum 3 conductor), #18 AWG stranded, 300V minimum insulation, 25 ft. (7.62m) maximum length.
4. One 25 pin Cannon connector and shell.
5. Cannon P/N DB-25P connector, or equivalent.
6. Cannon P/N DB-C2-J9 shell.

### Assembly and Wiring

All components should be assembled and wired as shown in Figure 43. Strip the outside insulation back several inches and individual wires about 3/8" (9.5 mm) to connect the cable at the Microboard. Do not connect the shield at the printer-end of the cable.

### Obtaining a Printout

A printout is obtained by pressing the PRINT key on the keypad and then pressing either the OPER DATA key or HISTORY key.

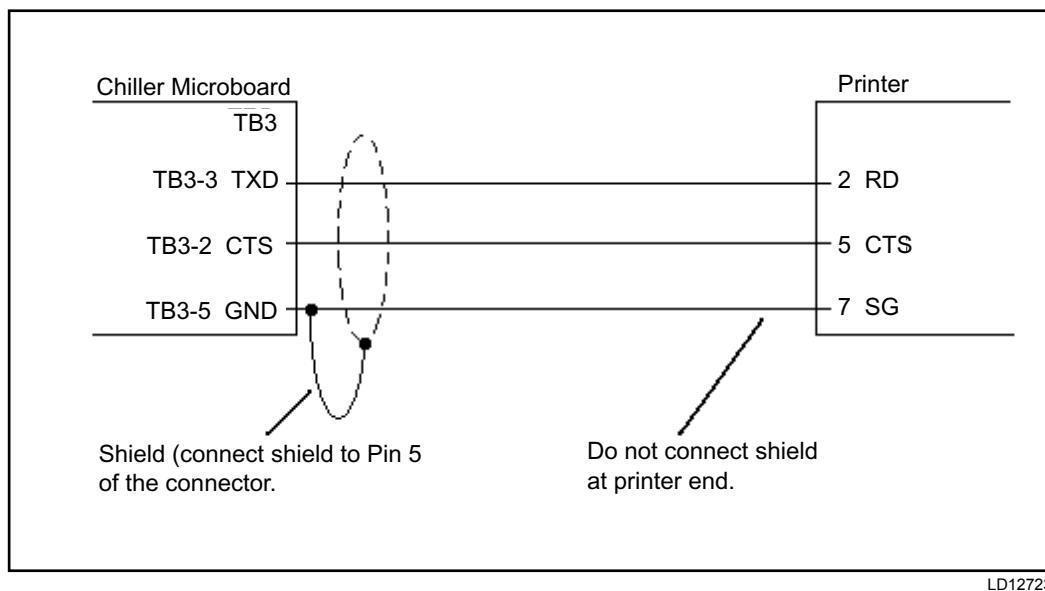

**FIGURE 43 - PRINTER TO MICROBOARD ELECTRICAL CONNECTIONS**

## TROUBLESHOOTING

TABLE 32 - TROUBLESHOOTING

PROBLEM	CAUSE	SOLUTION
<b>NO DISPLAY ON PANEL. UNIT WILL NOT OPERATE</b>	<ol style="list-style-type: none"> <li>No 115VAC to 24VAC Transformer.</li> <li>No 24VAC to Microboard.</li> <li>Control Transformer defective, no 24VAC output.</li> <li>Short in wire to temp. sensors or pressure transducers.</li> <li>Defective IPU II &amp; I/O Board or the Display Board.</li> </ol>	<ol style="list-style-type: none"> <li>Check wiring and fuse 1FU.</li> <li>Check wiring emergency stop contacts 5 to L of XTBC2 Terminal Block.</li> <li>Replace Control Transformer.</li> </ol> <ol style="list-style-type: none"> <li>Check wiring Control Transformer to Microboard.</li> <li>Replace Control Transformer.</li> </ol> <ol style="list-style-type: none"> <li>Unplug connections at IPU II &amp; I/O Board to isolate.</li> <li>Replace IPU II &amp; I/O Board or the Display Board.</li> </ol> <div style="border: 1px solid black; padding: 5px; display: inline-block; text-align: center;">         NOTE     </div> <p><b>Contact Johnson Controls Service before replacing circuit Boards!</b></p>
<b>FLOW SWITCH/REM STOP NO RUN PERMISSIVE</b>	<ol style="list-style-type: none"> <li>No chilled liquid flow.</li> <li>Flow switch improperly installed.</li> <li>Defective flow switch.</li> <li>Remote cycling device open.</li> </ol>	<ol style="list-style-type: none"> <li>Check chilled liquid flow.</li> <li>Check that the flow switch is installed according to manufacturer's instructions.</li> <li>Replace flow switch.</li> <li>Check cycling devices connected to terminals 13 and 14 of the XTBC1 Terminal Block.</li> </ol>
<b>LOW SUCTION PRESSURE FAULT</b>	<ol style="list-style-type: none"> <li>Improper suction pressure cutouts adjustments.</li> <li>Low refrigerant charge.</li> <li>Fouled filter dryer.</li> <li>TXV defective.</li> <li>Reduced flow of chilled liquid through the cooler.</li> <li>Defective suction pressure transducer/low pressure switch or wiring.</li> <li>LLSV defective</li> </ol>	<ol style="list-style-type: none"> <li>Adjust per recommended settings.</li> <li>Repair leak if necessary and add refrigerant.</li> <li>Change dryer/core.</li> <li>Replace TXV.</li> <li>Check GPM (See <i>Operational Limitations (English)</i> on page 43). Check operation of pump, clean pump strainer, purge chilled liquid system of air.</li> <li>Replace transducer/low pressure switch or faulty switch or wiring. See <i>SECTION 9 – SERVICE AND TROUBLESHOOTING</i> for pressure/voltage formula.</li> <li>Replace LLSV</li> </ol>
<b>HIGH DISCHARGE PRESSURE FAULT</b>	<ol style="list-style-type: none"> <li>Condenser fans not operating or operating backwards.</li> <li>Too much refrigerant.</li> <li>Air in refrigerant system.</li> <li>Defective discharge pressure transducer.</li> </ol>	<ol style="list-style-type: none"> <li>Check fan motor, and contactors. Assure fan blows air upward.</li> <li>Remove refrigerant.</li> <li>Evacuate and recharge system.</li> <li>Replace discharge pressure transducer. See <i>SECTION 9 – SERVICE AND TROUBLESHOOTING</i> for pressure/voltage formula on page 167.</li> </ol>

**TABLE 32 - TROUBLESHOOTING (CONT'D)**

PROBLEM	CAUSE	SOLUTION
<b>LOW LIQUID TEMP FAULT</b>	1. Improperly adjusted leaving chilled liquid temp. cutout (glycol only). 2. Micro panel setpoint/range values improperly programmed. 3. Chilled liquid flow too low. 4. Defective LWT or RWT sensor (assure the sensor is properly installed in the bottom of the well with a generous amount of heat conductive compound).	1. Re-program the leaving chilled liquid temp. cutout. 2. Re-adjust setpoint/range. 3. Increase chilled liquid flow. See <i>Operational Limitations (English)</i> on page 43). 4. Compare sensor against a known good Temperature sensing device. See <i>Table 30</i> on page 166
<b>MP / HPCO FAULT</b>	1. Compressor internal motor protector (MP) open. 2. External overload tripped. 3. HPCO switch open. 4. Defective HPCO switch. 5. Defective CR relay.	1. Verify refrigerant charge is not low. Verify superheat setting of 10 °F to 15 °F (5.6 °C to 8.3 °C). Verify correct compressor rotation. Verify compressor is not overloaded. 2. Determine cause and reset. 3. See High Press. Disch. Fault. 4. Replace HPCO switch. 5. Replace relay.
<b>COMPRESSOR(S) WON'T START</b>	1. Demand not great enough. 2. Defective water temperature sensor. 3. Contactor/Overload failure. 4. Compressor failure.	1. No problem. <i>Consult Installation Manual to aid in understanding compressor operation and capacity control.</i> 2. Compare the display with a thermometer. Should be within plus or minus 2 degrees. See <i>Table 30</i> on page 166 for RWT/LWT temp./voltage table. 3. Replace defective part. 4. Diagnose cause of failure and replace.
<b>LACK OF COOLING EFFECT</b>	1. Fouled evaporator surface. Low suction pressure will be observed. 2. Improper flow through the evaporator. 3. Low refrigerant charge. Low suction pressure will be observed.	1. Contact the local Johnson Controls service representative. 2. Reduce flow to within chiller design specs. See <i>Operational Limitations (English)</i> on page 43). 3. Check subcooling and add charge as needed.

THIS PAGE INTENTIONALLY LEFT BLANK

## SECTION 10 – MAINTENANCE

It is the responsibility of the equipment owner to perform maintenance on the system.

### Important

If system failure occurs due to improper maintenance during the warranty period, Johnson Controls will not be liable for costs incurred to return the system to satisfactory operation. The following is intended only as a guide and covers only the chiller unit components. It does not cover other related system components which may or may not be furnished by Johnson Controls. System components should be maintained according to the individual manufacture's recommendations as their operation will affect the operation of the chiller.

### COMPRESSORS

#### Oil Level check

The oil level can only be tested when the compressor is running in stabilized conditions, to ensure that there is no liquid refrigerant in the lower shell of the compressor. When the compressor is running at stabilized conditions, the oil level must be between 1/4 and 3/4 in the oil sight glass. **At shutdown, it is acceptable if the oil level falls to the bottom limit of the oil sight glass.**

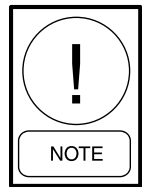

*Use YORK "V" oil 011-00949-000, when adding oil to Copeland compressor. The Bitzer compressor uses 011-00982-000 oil.*

#### Oil Analysis

The oil used in these compressors is pale yellow in color (POE oil). If the oil color darkens or exhibits a change in color, this may be an indication of contaminants in the refrigerant system. If this occurs, an oil sample should be taken and analyzed. If contaminants are present, the system must be cleaned to prevent compressor failure.

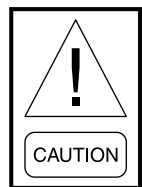

*Never use the scroll compressor to pump the refrigerant system down into a vacuum. Doing so will cause internal arcing of the compressor motor which will result in failure of compressor.*

### CONDENSER FAN MOTORS

Condenser fan motors are permanently lubricated and require no maintenance.

### Condenser MCHX

Dirt should not be allowed to accumulate on the MCHX condenser surfaces. Cleaning should be as often as necessary to keep coils clean.

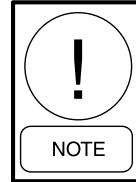

*Exercise care when cleaning the MCHX so that the fins are not damaged.*

### CONDENSER MCHX CLEANING

The cleaning procedure for the condenser MCHX is significantly different than tube and fin type MCHX. Care must be taken to understand the differences to avoid damage to the MCHX. These differences require a number of DO NOT's that must be observed:

- DO NOT use coil cleaners or any chemical on a MCHX. This can cause severe damage to the coils.
- DO NOT use a pressure washer to clean the MCHX. While it is possible to clean a the MCHX with a pressure washer, it's also possible to destroy it.
- DO NOT contact the MCHX with a hard surface such as a hose nozzle or metal vacuum nozzle or any other tool.

Follow the three steps below for cleaning the MCHX:

1. Remove surface debris such as dirt, leaves, insects, fibers, etc. with a vacuum cleaner having a soft attachment rather than a metal tube. Compressed air blown from the inside out can also be used. When brushing debris off the face of the MCHX a soft bristle (not wire) brush can be used. Do not scrape the MCHX with the vacuum nozzle, air nozzle, or any other tool.

2. Rinse the MCHX with tap water. Do not use MCHX cleaners. Rinse the coil from the inside out, running water through every passage in the heat exchanger surface until it is clean. Use a gentle spray from a spray nozzle with a plastic end or put your finger on the end of the spray nozzle to reduce impact and provide a gentle spray.
3. Because of the fin geometry, the condenser MCHX retain water more than tube and fin style. It is generally recommended to blow or vacuum out the rinse water from the MCHX to speed drying and prevent water pooling.

### OPERATING PARAMETERS

Regular checks of the system should be performed to ensure that operating temperatures and pressures are within limitations, and that the operating controls are set within proper limits. See *SECTION 8 – UNIT OPERATION*, *SECTION 6 – COMMISSIONING*, and *SECTION 4 – INSTALLATION* of this manual.

### ON-BOARD BATTERY BACK-UP

The Real Time Clock chip (U5) located on the 031-02630 IPU II board that maintains the date/time and stores customer programmed setpoints.

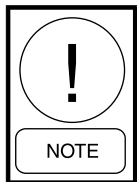

***Do not confuse JP1 on the IPU II (031-02630) board with JP1 on the I/O (031-02550) board.***

### BRAZED PLATE HEAT EXCHANGER (EVAPORATOR) HEATER



***The internal power supply to the Evaporator Heater is 120VAC. Disconnecting 120VAC power from the unit, at or below freezing temperatures, can result in damage to the evaporator and unit as a result of the chilled liquid freezing.***

### OVERALL UNIT INSPECTION

In addition to the checks listed on this page, periodic overall inspections of the unit should be accomplished to ensure proper equipment operation. Items such as loose hardware, component operation, refrigerant leaks, unusual noises, etc. should be investigated and corrected immediately.

## TEMPERATURE CONVERSION CHART

Temperature Conversion Chart -  
 Actual Temperatures

° F	=	° C	° C	=	° F
0		-17.8	-18		-0.4
4		-15.6	-16		3.2
8		-13.3	-14		6.8
12		-11.1	-12		10.4
16		-8.9	-10		14
20		-6.7	-8		17.6
24		-4.4	-6		21.2
28		-2.2	-4		24.8
32		0.0	-2		28.4
36		2.2	0		32
40		4.4	2		35.6
44		6.7	4		39.2
48		8.9	6		42.8
52		11.1	8		46.4
56		13.3	10		50
60		15.6	12		53.6
64		17.8	14		57.2
68		20.0	16		60.8
72		22.2	18		64.4
76		24.4	20		68
80		26.7	22		71.6
84		28.9	24		75.2
88		31.1	26		78.8
92		33.3	28		82.4
96		35.6	30		86
100		37.8	32		89.6
104		40.0	34		93.2
108		42.2	36		96.8
112		44.4	38		100.4
116		46.7	40		104
120		48.9	42		107.6
124		51.1	44		111.2
128		53.3	46		114.8
132		55.6	48		118.4
136		57.8	50		122
140		60.0	52		125.6
144		62.2	54		129.2
148		64.4	56		132.8
152		66.7	58		136.4
156		68.9	60		140
160		71.1	62		143.6
164		73.3	64		147.2
168		75.6	66		150.8
172		77.8	68		154.4
176		80.0	70		158
180		82.2	72		161.6
184		84.4	74		165.2
188		86.7	76		168.8
192		88.9	78		172.4
196		91.1	80		176
200		93.3	82		179.6
204		95.6	84		183.2
208		97.8	86		186.8
212		100.0	88		190.4
216		102.2	90		194
220		104.4	92		197.6
224		106.7	94		201.2
228		108.9	96		204.8
232		111.1	98		208.4
236		113.3	100		212
240		115.6	102		215.6
244		117.8	104		219.2

Temperature Conversion Chart -  
 Differential Temperatures

° F	=	° C	° C	=	° F
0		0	0		0
4		2.2	2		3.6
8		4.4	4		7.2
12		6.7	6		10.8
16		8.9	8		14.4
20		11.1	10		18
24		13.3	12		21.6
28		15.6	14		25.2
32		17.8	16		28.8
36		20	18		32.4
40		22.2	20		36
44		24.4	22		39.6
48		26.7	24		43.2
52		28.9	26		46.8
56		31.1	28		50.4
60		33.3	30		54

Pressure Conversion Chart -  
 Gauge or Differential

PSI	=	BAR	BAR	=	PSI
20		1.38	1.5		21.8
30		2.07	2		29
40		2.76	2.5		36.3
50		3.45	3		43.5
60		4.14	3.5		50.8
70		4.83	4		58
80		5.52	4.5		65.3
90		6.21	5		72.5
100		6.9	5.5		79.8
110		7.59	6		87
120		8.28	6.5		94.3
130		8.97	7		101.5
140		9.66	7.5		108.8
150		10.34	8		116
160		11.03	8.5		123.3
170		11.72	9		130.5
180		12.41	9.5		137.8
190		13.1	10		145
200		13.79	10.5		152.3
210		14.48	11		159.5
220		15.17	11.5		166.8
230		15.86	12		174
240		16.55	12.5		181.3
250		17.24	13		188.5
260		17.93	13.5		195.8
270		18.62	14		203
280		19.31	14.5		210.3
290		20	15		217.5
300		20.69	15.5		224.8
310		21.38	16		232
320		22.07	16.5		239.3
330		22.76	17		246.5
340		23.45	17.5		253.8
350		24.14	18		261
360		24.83	18.5		268.3
370		25.52	19		275.5
380		26.21	19.5		282.8
390		26.9	20		290
400		27.59	20.5		297.3

**R-410A PRESSURE TEMPERATURE CHART**

PSIG	TEMP °F	PSIG	TEMP °F
0	-60	78	20
2	-58	80	21
4	-54	85	24
6	-50	90	26
8	-46	95	29
10	-42	100	32
12	-39	105	34
14	-36	110	36
16	-33	115	39
18	-30	120	41
20	-28	125	43
22	-26	130	45
24	-24	135	47
26	-20	140	49
28	-18	145	51
30	-16	150	53
32	-14	160	57
34	-12	170	60
36	-10	180	64
38	-8	190	67
40	-6	200	70
42	-4	210	73
44	-3	220	76
46	-2	225	78
48	0	235	80
50	1	245	83
52	3	255	85
54	4	265	88
56	6	275	90
58	7	285	92
60	8	295	95
62	10	305	97
64	11	325	101
66	13	355	108
68	14	375	112
70	15	405	118
72	16	500	134
74	17	600	149
76	19	700	159

The following factors can be used to convert from English to the most common SI Metric values.

**TABLE 33 - SI METRIC CONVERSION**

MEASUREMENT	MULTIPLY ENGLISH UNIT	BY FACTOR	TO OBTAIN METRIC UNIT
Capacity	Tons Refrigerant Effect (ton)	3.516	Kilowatts (kW)
Power	Horsepower	0.7457	Kilowatts (kW)
Flow Rate	Gallons / Minute (gpm)	0.0631	Liters / Second (l/s)
Length	Feet (ft)	0.3048	Meters (m)
	Inches (in)	25.4	Millimeters (mm)
Weight	Pounds (lbs)	0.4536	Kilograms (kg)
Velocity	Feet / Second (fps)	0.3048	Meters / Second (m/s)
Pressure Drop	Feet of Water (ft)	2.989	Kilopascals (kPa)
	Pounds / Square Inch (psi)	6.895	Kilopascals (kPa)

### TEMPERATURE

To convert degrees Fahrenheit (°F) to degrees Celsius (°C), subtract 32° and multiply by 5/9 or 0.5556.

Example:  $(45.0^{\circ}\text{F} - 32^{\circ}) \times 0.5556 = 7.22^{\circ}\text{C}$

To convert a temperature range (i.e., a range of 10°F) from Fahrenheit to Celsius, multiply by 5/9 or 0.5556.

Example:  $10.0^{\circ}\text{F range} \times 0.5556 = 5.6^{\circ}\text{C range}$

