

IMPORTANT!

READ BEFORE PROCEEDING!

GENERAL SAFETY GUIDELINES

This equipment is a relatively complicated apparatus. During installation, operation maintenance or service, individuals may be exposed to certain components or conditions including, but not limited to: refrigerants, materials under pressure, rotating components, and both high and low voltage. Each of these items has the potential, if misused or handled improperly, to cause bodily injury or death. It is the obligation and responsibility of operating/service personnel to identify and recognize these inherent hazards, protect themselves, and proceed safely in completing their tasks. Failure to comply with any of these requirements could result in serious damage to the equipment and the property in

which it is situated, as well as severe personal injury or death to themselves and people at the site.

This document is intended for use by owner-authorized operating/service personnel. It is expected that this individual possesses independent training that will enable them to perform their assigned tasks properly and safely. It is essential that, prior to performing any task on this equipment, this individual shall have read and understood this document and any referenced materials. This individual shall also be familiar with and comply with all applicable governmental standards and regulations pertaining to the task in question.



External wiring, unless specified as an optional connection in the manufacturer's product line, is not to be connected inside the OptiView cabinet. Devices such as relays, switches, transducers and controls and any external wiring must not be installed inside the micro panel. All wiring must be in accordance with Johnson Controls' published specifications and must

be performed only by a qualified electrician. Johnson Controls will NOT be responsible for damage/problems resulting from improper connections to the controls or application of improper control signals. Failure to follow this warning will void the manufacturer's warranty and cause serious damage to property or personal injury.

CHANGEABILITY OF THIS DOCUMENT

In complying with Johnson Controls' policy for continuous product improvement, the information contained in this document is subject to change without notice. Johnson Controls makes no commitment to update or provide current information automatically to the manual owner. Updated manuals, if applicable, can be obtained by contacting the nearest Johnson Controls Service office or accessing the Johnson Controls QuickLIT website at <http://cgproducts.johnsoncontrols.com>.

Operating/service personnel maintain responsibility for the applicability of these documents to the equipment. If there is any question regarding the applicability of these documents, the technician should verify whether the equipment has been modified and if current literature is available from the owner of the equipment prior to performing any work on the chiller.

LIST OF FIGURES

FIGURE 1 - Elementary Diagram	6
FIGURE 2 - Elementary Diagram	9
FIGURE 3 - Elementary Diagram	10
FIGURE 4 - Microboard Diagram	12
FIGURE 5 - Display Interface Board	14
FIGURE 6 - Timing Diagram.....	15
FIGURE 7 - Pressure Temperature Chart	15
FIGURE 8 - Connection Diagram (UL).....	16
FIGURE 9 - Connection Diagram (CE).....	18
FIGURE 10 - Connection Diagram	20
FIGURE 11 - Connection Diagram	22
FIGURE 12 - Connection Diagram	24
FIGURE 13 - Variable Speed Oil Pump Drive Panel (200-240 and 380-480V).....	26

NOTES

1. This wiring diagram describes the standard electronic control scheme for use with an YORK Electro-Mechanical Starter. For details of standard modifications. Refer to 160.75-PW4.
2. Field wiring to be in accordance with the National Electrical Code as well as all other applicable codes and specifications. See product form 160.75-PW1 for field wiring connections.













Caution: Field wiring contacts may have voltage present when power is removed.

Field wiring contacts could be connected to external power sources.
3. Numbers along the left side of the diagram are line identification numbers. The numbers along the right side indicate the line number location of the relay contacts. An underlined contact location signifies a normally closed contact.
4. Main control panel class 1 field wiring terminal connection points are indicated by numbers within a rectangle. I.E. 15. Main control panel factory wiring terminal connection points are indicated by numbers within a triangle. I.E. 5. Components markings are indicated by numbers within a circle. I.E. C1. Numbers adjacent to circuit lines are the circuit identification numbers.
5. To cycle unit on and off automatically with contacts other than those shown, install a cycling device between terminals 1 and 13 (line 38) (see note 9). If a cycling device is installed, the jumper must be removed between terminals 1 and 13.
6. Compressor motor starter with starter interlock contacts (rated 0.5 to 1.0 Amp @ 24 volts A.C.) must be per form 160.45-PA5.1. Control panel shall be grounded.
7. Units installed in Canada must have a field supplied CSA approved 30 amp disconnect switch and a 20 amp dual element fuse mounted external to the control panel for 115 volt control supply.
8. To stop the unit and not to permit it to start again, install a stop device between terminals 1 and 8 (line 33) (see note 9). Remote stop switch may be connected between terminals 1, 7, 8 (lines 32 and 33)(see note 9). Remote Start-Stop switch (line 32) is operative only in "Remote" operating mode.

10. Maximum allowable current draw for the sum of all loads is 2 Amps holding, 10 Amps inrush.
11. Contact rating is 5 Amps resistive at 120 Volts AC or 240 Volts AC.
13. A jumper is installed between terminals 24 and 25 for normal operation. To check motor rotation on initial start-up, the jumper may be removed as a momentary switch installed between terminals 24 and 25. Depress the start switch on the control panel. After completion of the pre lube sequence jog the motor with the momentary switch. When proper rotation is obtained, replace the momentary switch with a jumper. The momentary switch must have a minimum contact rating of 1 FLA, 10 LRA at 115 volts AC.

Caution: A temporary momentary switch or jumper is the only connection permitted between terminals 24 and 25. Connections of any other devices to either terminals may cause inadvertent compressor start-up.
14. Solid state motor overload contact (CM) is set to trip at 105% FLA during momentary power interruptions (Power Fault), contact opens for 1 second.
15. For high and low voltage unite, the factory supplied jumper between 15 and 53 must be removed when Electro-mechanical starter overloads and/or safety devices are used. For high voltage (2300-4160) UL and CUL approved units only. Electro-mechanical compressor motor overloads (normally closed) must be connected between 15 and 53.
16. Contact rating is 5 Amps resistive @ 250 volts AC and 30 volts DC. 2 Amp inductive (.4 PF) @ 250 volts AC and 30 volts DC.
14. Field connected control power supply is not required. A control transformer is supplied on the Medium Voltage Solid State Starter and the Medium Voltage Variable Speed Drive.
15. Maximum allowable current draw for the sum of all loads is 2 amps holding, and 10 amps in rush.
16. Each 115VAC field-connected inductive load: I.E. Relay Coil, Motor Starter Coil, etc. shall have a transient suppressor wired in parallel with it's coil. Physically located at the coil. Spare transient suppressors and control circuit fuses are supplied in a bag attached to the green ground screw located in the lower left corner of the control panel.

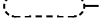
LEGEND

1BR	6 AMP CIRCUIT BREAKER (CE VERSION)
2BR	20 AMP CIRCUIT BREAKER (CE VERSION)
3BR	6 AMP CIRCUIT BREAKER (CE VERSION)
IHTR	3-PHASE THERMOSTATICALLY CONTROLLED 3000 WATT OIL HEATER AT LINE VOLTAGE (P6 AND LARGER) 1000 WATT 120 1-PHASE (P1 THRU P5)
ILEP	LOW EVAPORATOR PRESSURE (PROVIDED BY EVAP PRESSURE TRANSDUCER)
IM	3-PHASE OIL HEATER CONTACTOR
10L	2T PROTECTOR (346V AND 600V UNITS ONLY)
IT	CLASS 2 POWER SUPPLY TRANSFORMER
1TB	MEDIUM VOLTAGE TERMINAL
2TB	MEDIUM VOLTAGE TERMINAL
3M	CONDENSER PUMP MOTOR STARTER
IR	COMPRESSOR MOTOR / IHTR HEATER CONTROL RELAY (K-18 - LOCATED ON I/O BOARD)
3R	VS OIL PUMP DRIVE RUN RELAY
1SOL	OIL RETURN SOLENOID VALVE
2SOL	LIQUID LINE SOLENOID VALVE (USED ON "J" COMPRESSORS ONLY)
1SS	DPDT 3 POSITION ROCKER SWITCH
2T, 3T, 4T	BUCK/BOOST TRANSFORMERS IKVA (346V AND 575/600 UNITS ONLY)
CM	SOLID STATE OVERLOAD/POWER FAULT CONTACTS (PART OF MV-SSS LOGIC BOARD)
FDTs	FAULTY DISCHARGE TEMPERATURE SENSOR
FLA	FULL LOAD AMPS (COMPRESSOR MOTOR)
FU	FUSE
PGD	PROXIMITY GAP DISTANCE (PROBE LOCATED IN COMPRESSOR)
HDT	REFRIG. HIGH DISCHARGE TEMPERATURE (PROVIDED BY RT2)
HOP	HIGH OIL PRESSURE (PROVIDED BY 2 TRANSDUCERS)
HOT	HIGH OIL TEMPERATURE (PROVIDED BY RT3)
HPCO	HIGH PRESSURE CUTOUT
K13, K14, K17	RELAYS MOUNTED ON I/O BOARD (SEE OPERATION MANUAL)
LCWT	LEAVING CHILLED WATER TEMPERATURE
LEP	LOW EVAPORATOR PRESSURE (PROVIDED BY EVAP. PRESSURE TRANSDUCER)
LLS	LIQUID LEVEL SENSOR (PROBE)
LOT	LOW OIL TEMPERATURE (PROVIDED BY RT3)
LOTD	LOW OIL TEMPERATURE DIFFERENTIAL (PROVIDED BY RT3 AND CONDENSER PRESSURE TRANSDUCER)
HGBP	HOT GAS BYPASS
L1	INDUCTOR 4A, 9mH (460VAC) OR 8A, 3mH (230VAC)
LVVSD	LOW VOLTAGE VARIABLE SPEED DRIVE
LWT	LOW WATER TEMPERATURE (PROVIDED BY RT1)
MOV	METAL OXIDE VARISTOR
OL	MOTOR STARTER OVERLOADS
OP	LOW OIL PRESSURE (PROVIDED BY 2 TRANSDUCERS)
OVA	ORIFICE VALVE ACTUATOR
PRV	PRE-ROTATION VANE MOTOR
RT1-RT9	RESISTANCE TEMPERATURE SENSING ELEMENT
RES	RESISTOR
 SUPR	TRANSIENT SUPPRESSOR
TB1, TB3, TB5	TERMINAL BLOCK, FACTORY WIRING - 
TB2, TB4	TERMINAL BLOCK, FIELD CONNECTION - 
TB6	TERMINAL BLOCK, FIELD (BOTTOM), FACTORY (TOP)
VGD	VARIABLE GEOMETRY DIFFUSER
VMP	VANE MOTOR POTENTIOMETER
VMS	VANE MOTOR SWITCH
VS	VARIABLE SPEED OIL PUMP DRIVE
	FIELD WIRING
	FACTORY WIRING
	CIRCUIT BOARD OR ENCLOSURE BOUNDRY
	JACK (J1, J2,)
	PLUG (P1, P2,)
	WIRE ENTRANCE IN CONTROL PANEL
	OPTION (WHEN SUPPLIED) BY YORK
	MECHANICAL LINKAGE
	SHIELDED CABLE
	METAL OXIDE VARISTOR
	TERMINAL LOCATED IN SSS / VSD (TB1 OR 1TB)

ELEMENTARY DIAGRAM (CONT'D)

035-21476-000
 SHT. 1 OF 11
 REV B

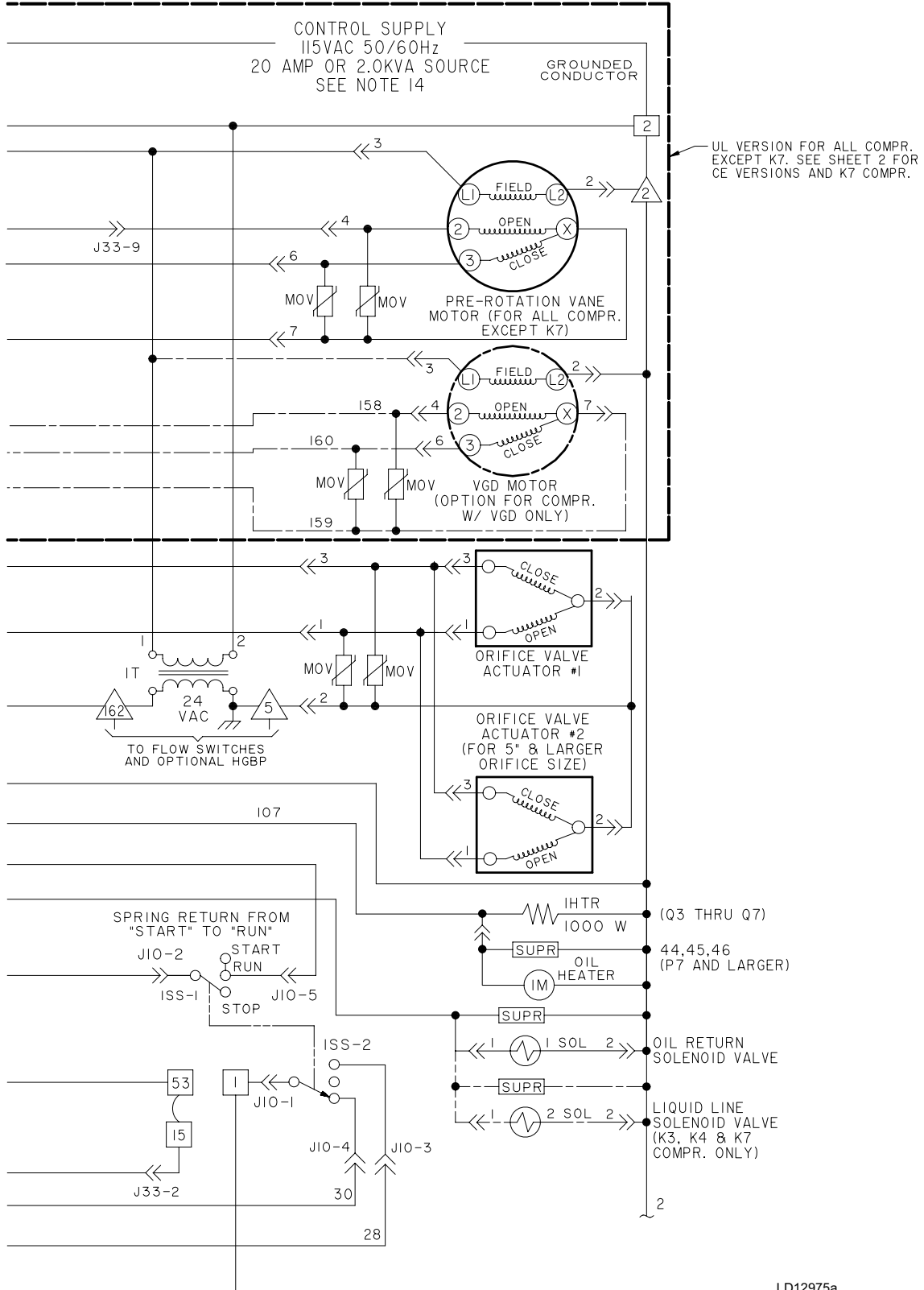

FIGURE 1 - ELEMENTARY DIAGRAM (CONT'D)

ELEMENTARY DIAGRAM (CONT'D)

035-21476-000
 SHT. 1 OF 11
 REV B

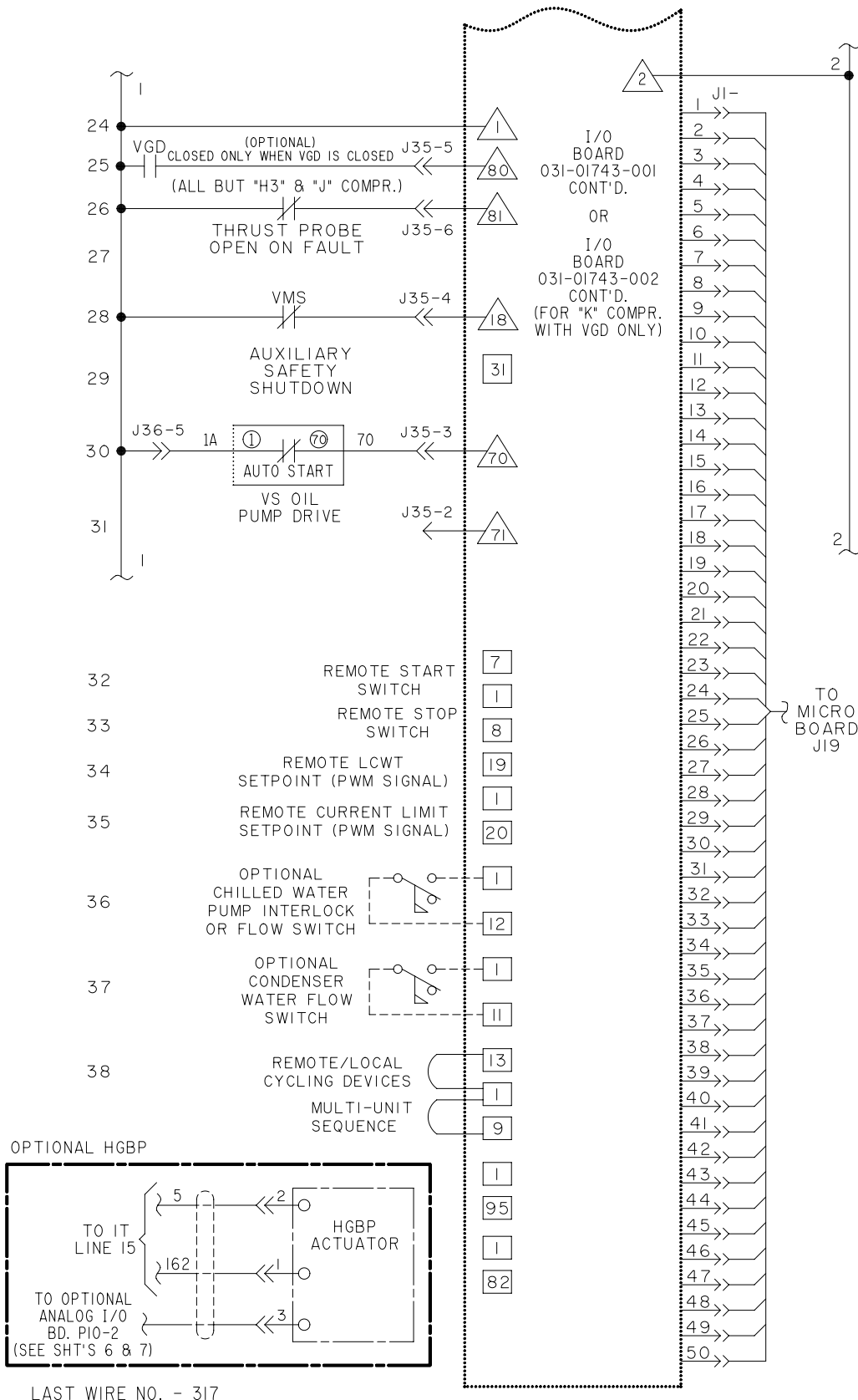
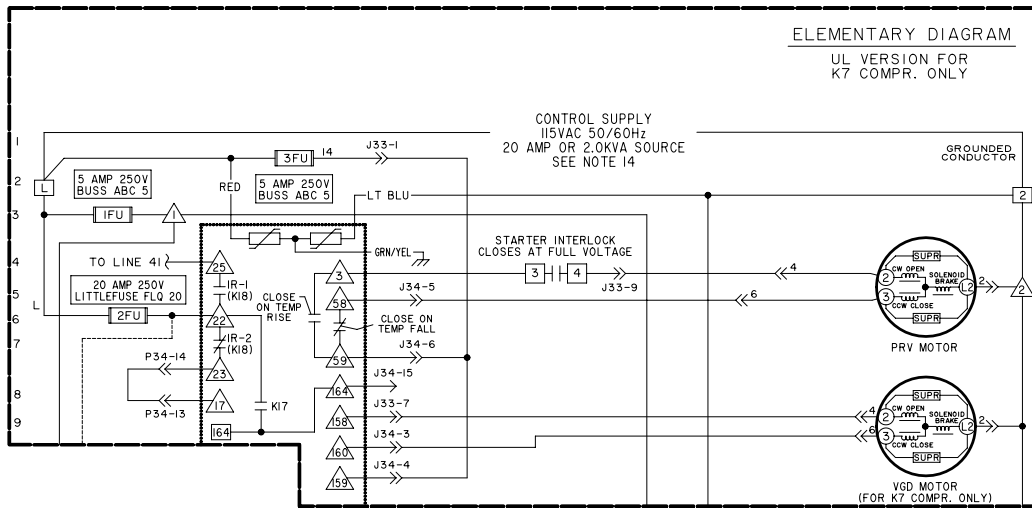

FIGURE 1 - ELEMENTARY DIAGRAM (CONT'D)

ELEMENTARY DIAGRAM



035-21476-000
 SHT. 2 OF 11
 REV B

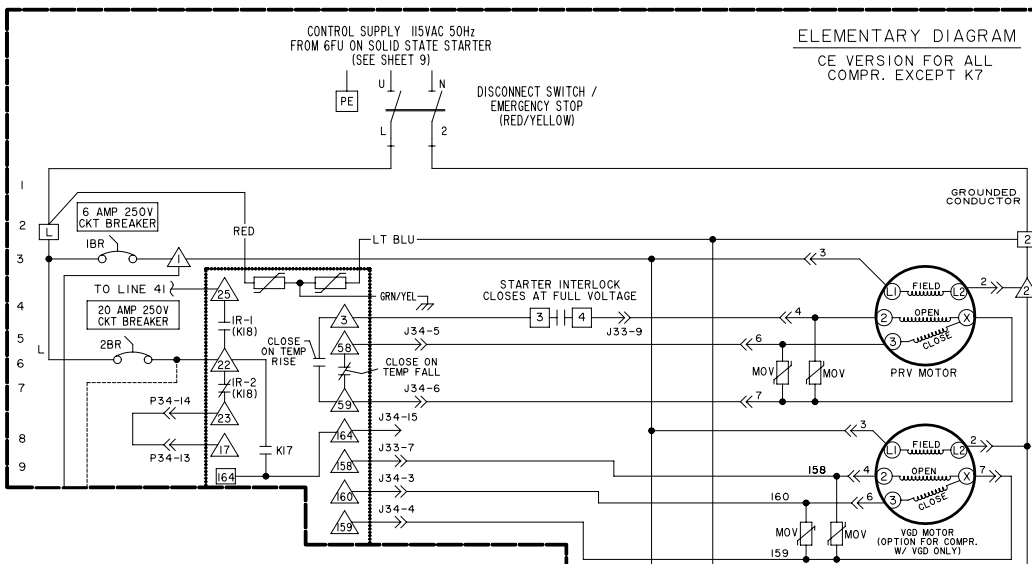
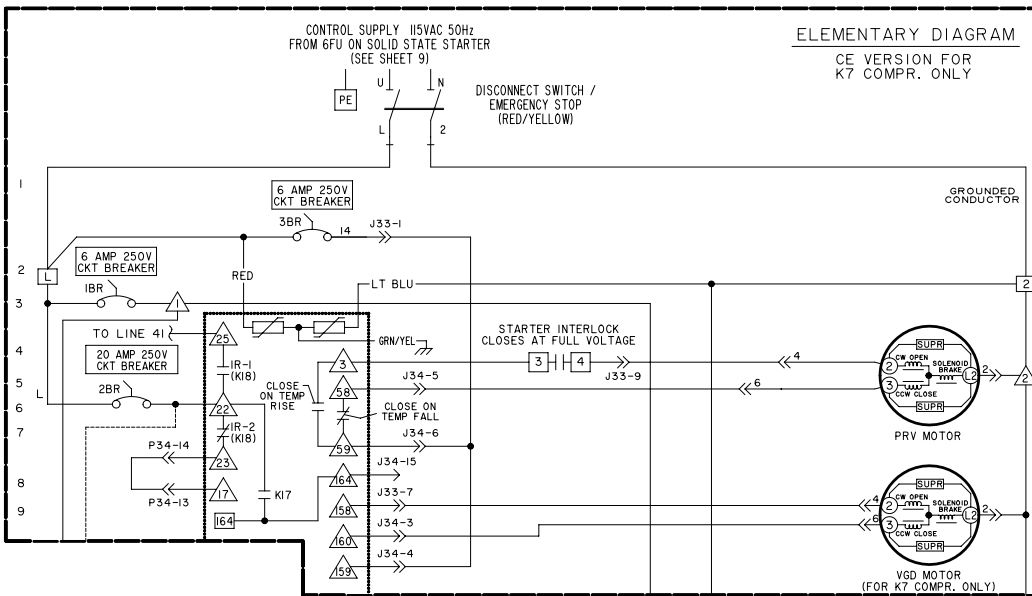
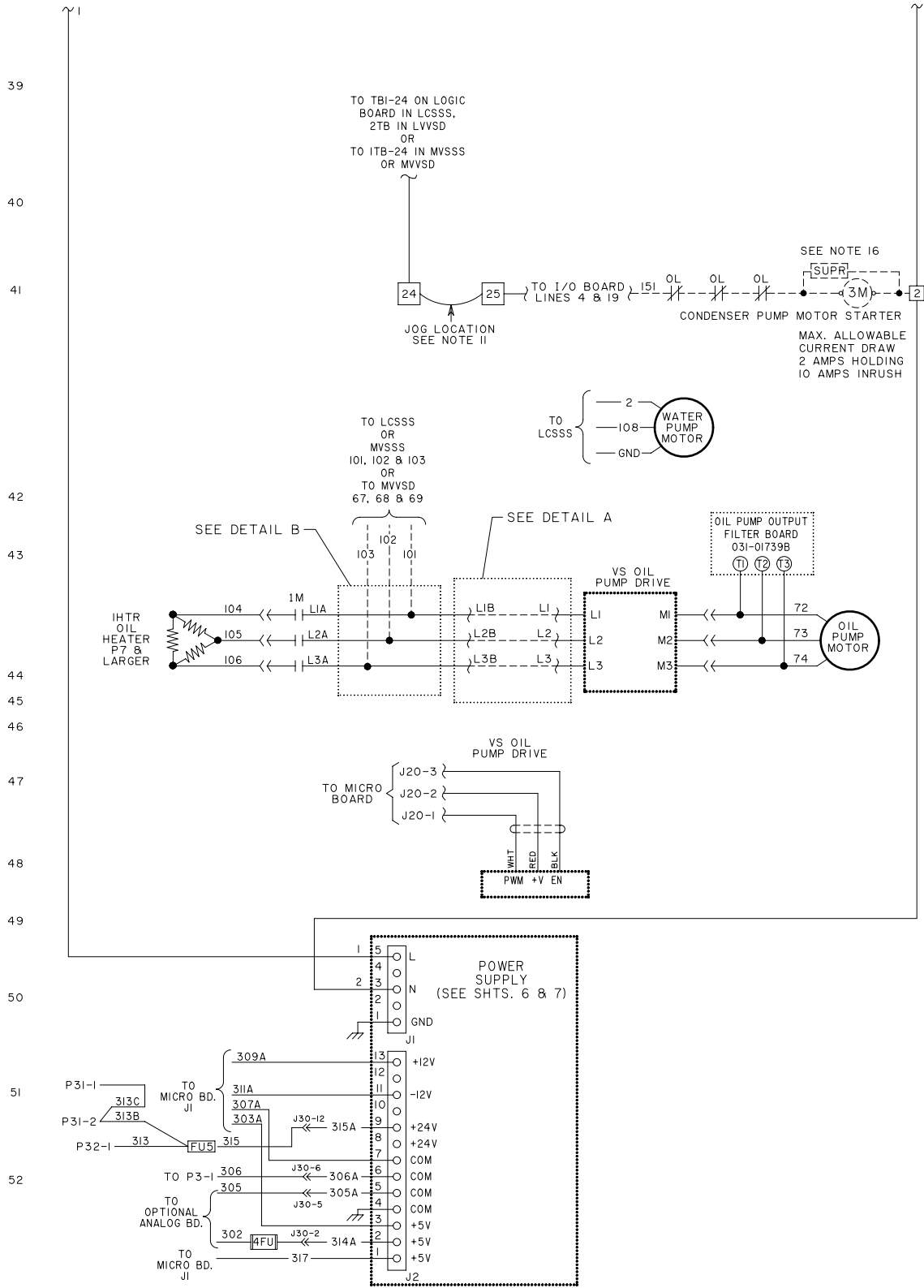

FIGURE 2 - ELEMENTARY DIAGRAM

ELEMENTARY DIAGRAM

035-21476-000
 SHT. 3 OF 11
 REV B



LD12978a

FIGURE 3 - ELEMENTARY DIAGRAM

ELEMENTARY DIAGRAM (CONT'D)

035-21476-000
 SHT. 3 OF 11
 REV B

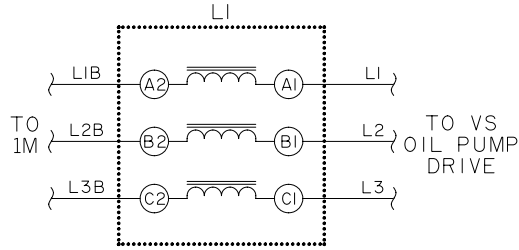
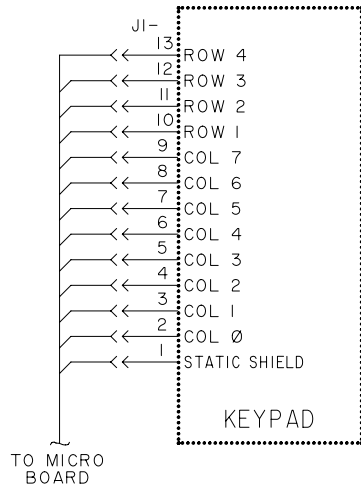

INDUCTOR LI TO BE USED ON ALL UNITS EXCEPT 346 AND 575/600 V UNITS

DETAIL A

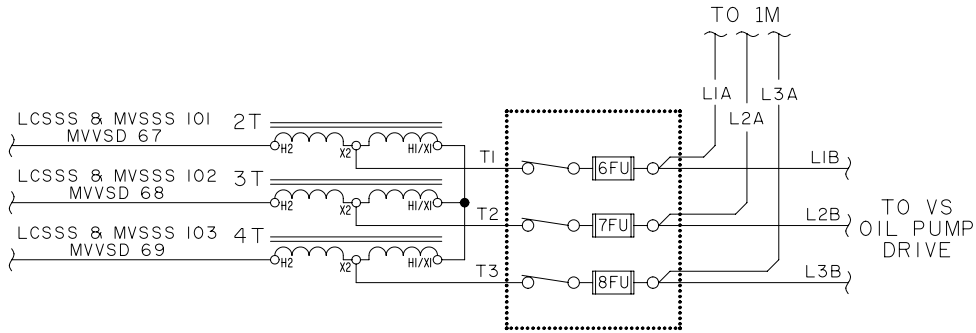

TRANSFORMERS 2T, 3T AND 4T ARE USED ON 346, 575 AND 600 V UNITS ONLY

DETAIL B

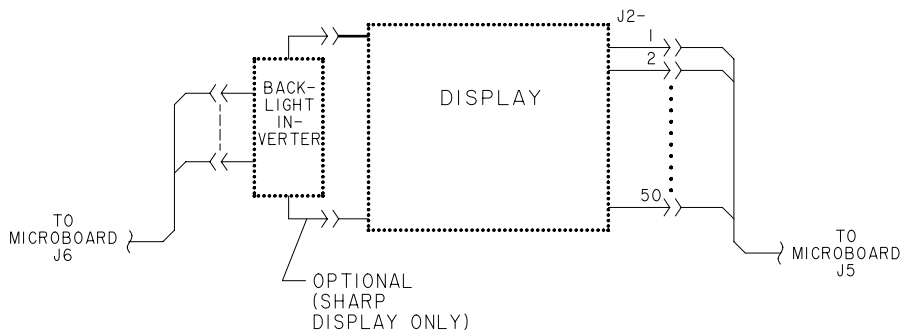

LD12953a

FIGURE 3 - ELEMENTARY DIAGRAM (CONT'D)

MICROBOARD DIAGRAM (031-02430)

035-21476-000
 SHT. 4 OF 11
 REV B

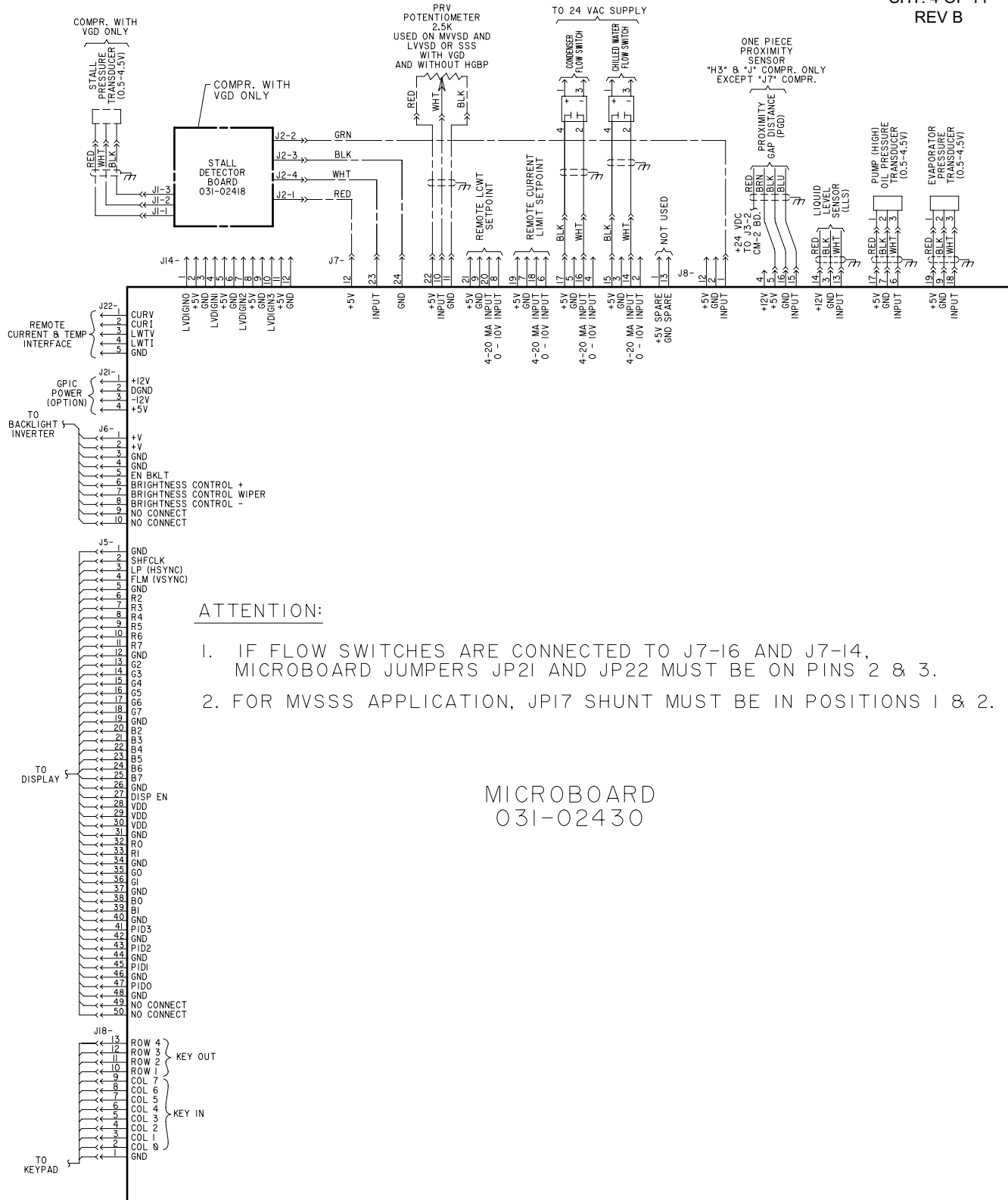

MICROBOARD
 031-02430

LD12981a

FIGURE 4 - MICROBOARD DIAGRAM

MICROBOARD DIAGRAM (031-02430)

035-21476-000
 SHT. 4 OF 11
 REV B

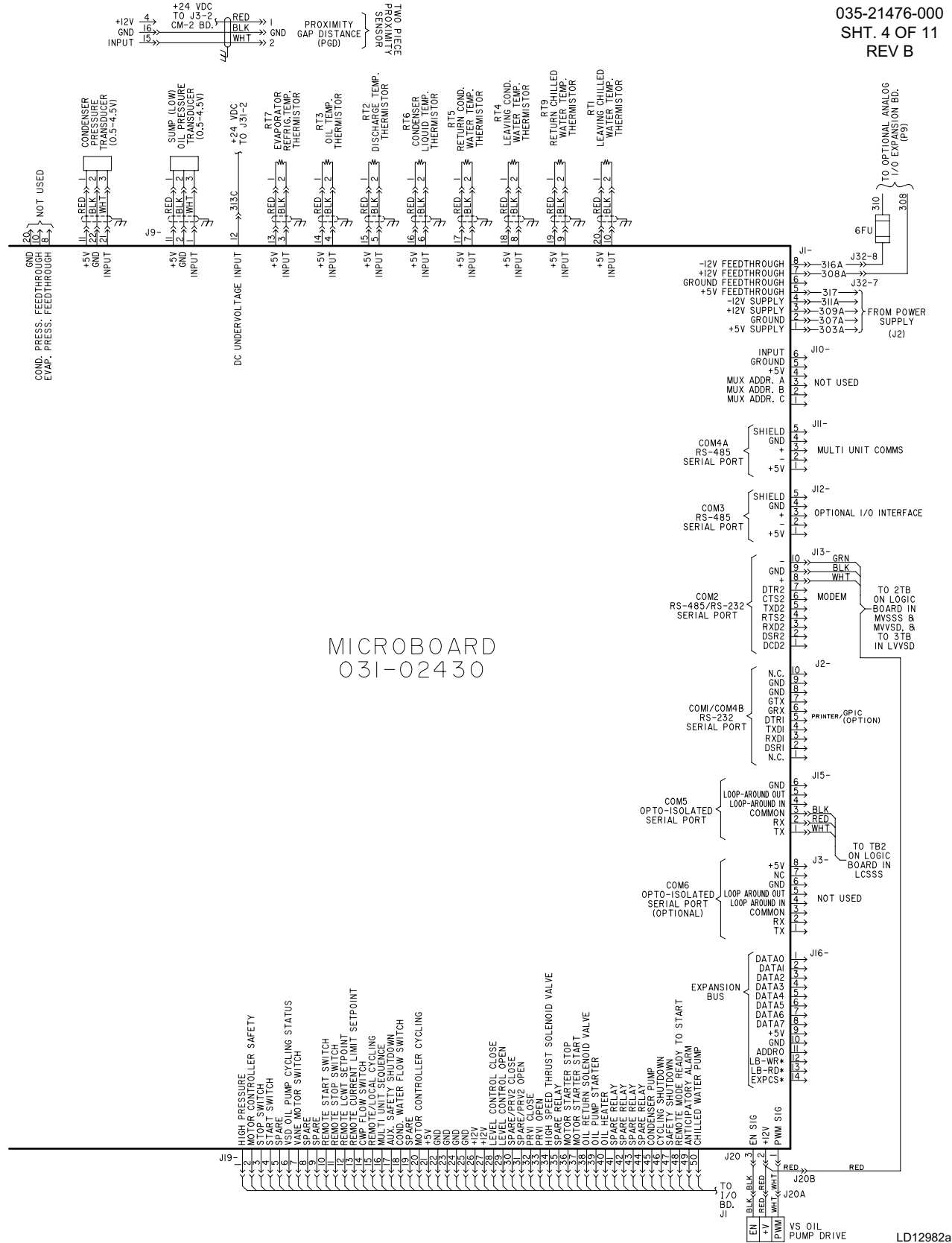
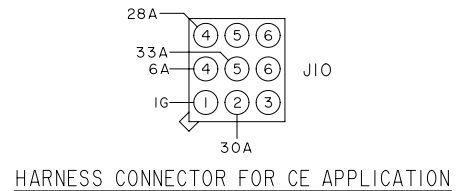
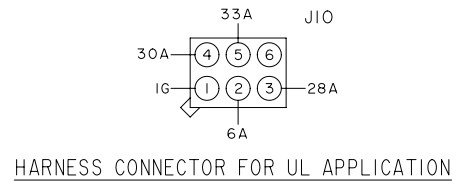
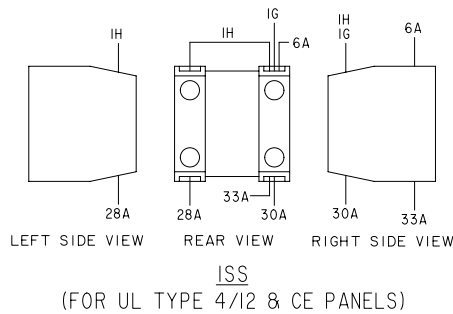
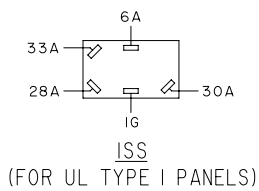
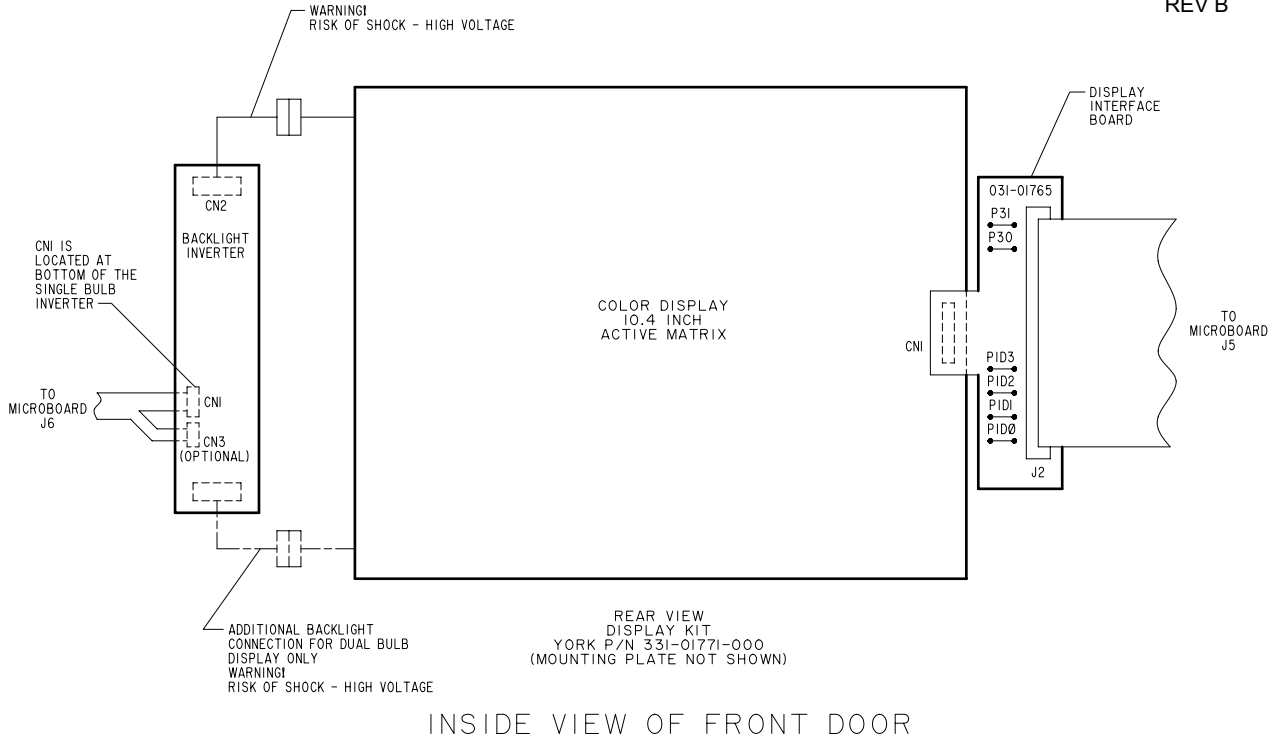

FIGURE 4 - MICROBOARD DIAGRAM (CONT'D)

DISPLAY INTERFACE BOARD

035-21476-000
 SHT. 5 of 11
 REV B



LD12983a

FIGURE 5 - DISPLAY INTERFACE BOARD

TIMING DIAGRAM

035-21476-000
 SHT. 3 OF 11
 REV B

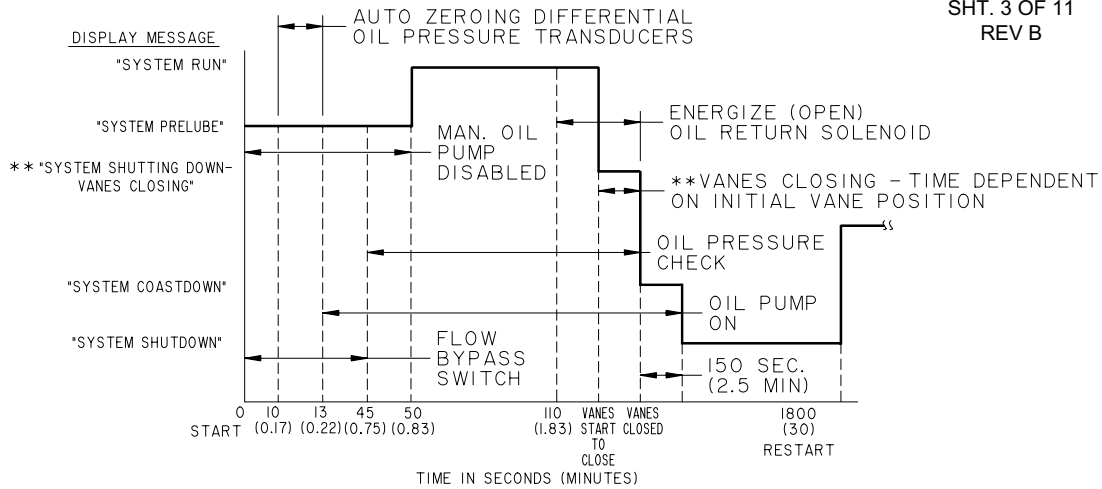

** - THIS FUNCTION IS NOT FOR ALL SHUTDOWNS - SEE OPERATOR'S MANUAL

LD17826

FIGURE 6 - TIMING DIAGRAM

PRESSURE TEMPERATURE CHART

035-21476-000
 SHT. 3 OF 11
 REV B

PRESSURE-TEMPERATURE CHART							
APPLICATION		DEVICE	UNITS	OPERATING POINT			
CHILLED WATER	BRINE			ON RISE		ON FALL	
✓	✓	HDT	DEG.F/DEG.C	220/104.4		219/103.9	
✓	✓	HOT	DEG.F/DEG.C	180/82.2		179/81.7	
✓	✓	OP	PSID/kPa	25/172		15/104	
FOR FURTHER INFORMATION, SEE OPERATOR'S MANUAL							
✓	✓	HP (R-134a)	PSIG/kPa	CUT-OUT 180/1241	INHIBIT PRV OPENING * 162.5/1120	ALLOW PRV OPENING * 160/1103	CUT-IN 120/827
✓		LEP (R-134a)	PSIG/kPa	CUT-IN 25.1/173	ALLOW PRV OPENING 28.0/193	INHIBIT PRV OPENING 27.0/186	CUT-OUT 25.0/172
	✓	ILEP	PSIG				
✓	✓	HOP	PSID/kPa	90/620.6		<90/620.6	
✓	✓	FDTs	DEG.F/DEG.C	30.0/-1.10		29.9/-1.20	
✓		LWT	DEG.F/DEG.C	PROGRAMMABLE PER OPERATIONS MANUAL FORM 160.54-01			
	✓	LWT	DEG.F/DEG.C				
✓	✓	LOT	DEG.F/DEG.C	71.0/21.7		55.0/12.8	
✓	✓	LOTD +	DEG.F/DEG.C	30/16.7		29.9/16.6	
✓	✓	LOTD ++	DEG.F/DEG.C	40/22.2		39.9/22.1	

* - FUNCTION PROVIDED BY CONDENSER TRANSDUCER.
 DEFAULT VALUES SHOWN ON TABLE. ACTUAL VALUES AS PROGRAMMED.
 + - APPLICABLE IF UNIT WAS SHUTDOWN FOR 30 MINS. OR LESS
 ++ - APPLICABLE IF UNIT WAS SHUTDOWN FOR GREATER THAN 30 MINS.

LD17827

FIGURE 7 - PRESSURE TEMPERATURE CHART

CONNECTION DIAGRAM (UL APPLICATIONS ONLY)

035-21476-000
 SHT. 6 OF 11
 REV B

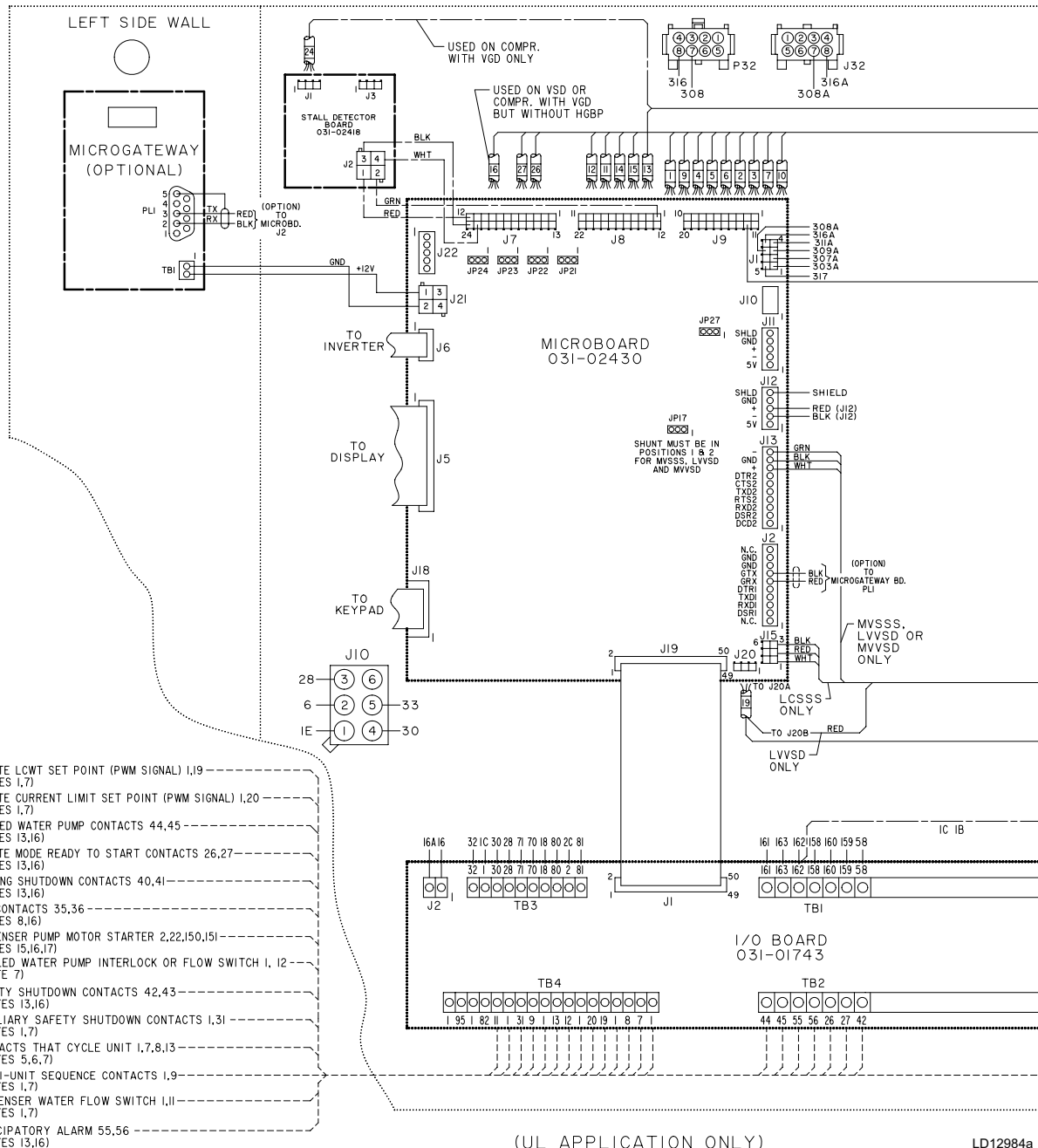

FIGURE 8 - CONNECTION DIAGRAM (UL)

CONNECTION DIAGRAM (CONT'D) (UL APPLICATIONS ONLY)

035-21476-000
 SHT. 6 OF 11
 REV B

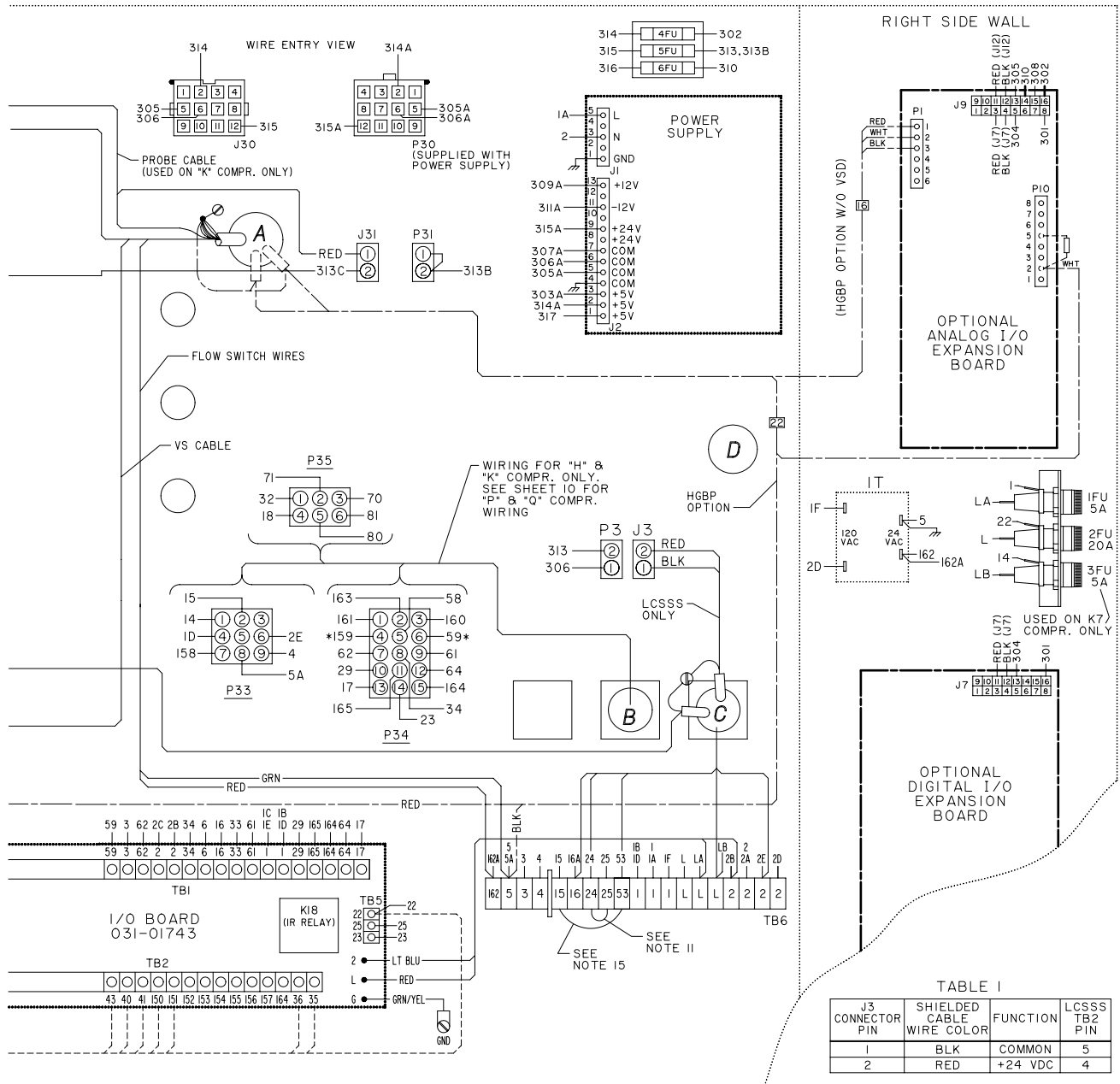
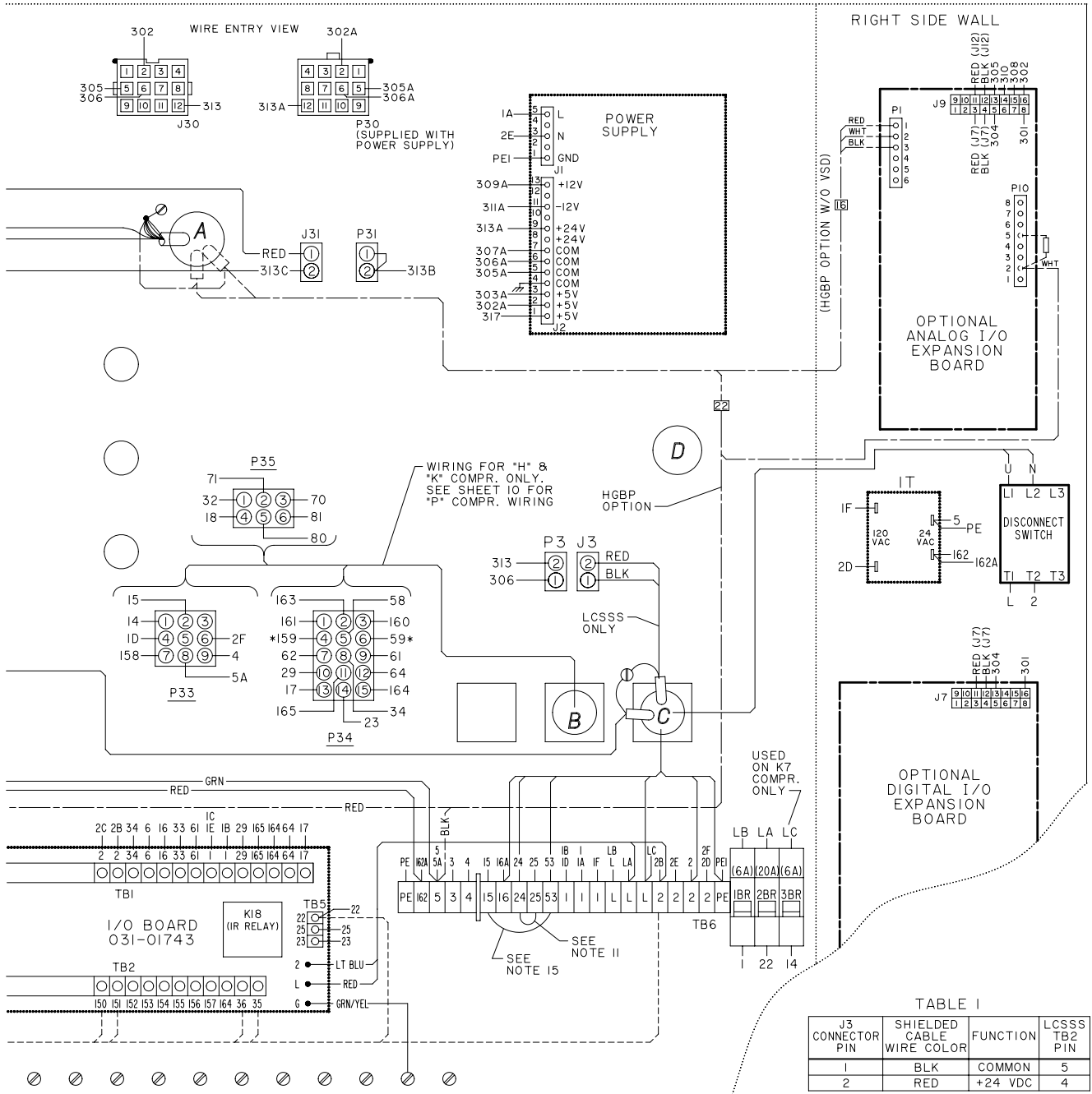

FIGURE 8 - CONNECTION DIAGRAM (UL) (CONT'D)

CONNECTION DIAGRAM (CONT'D) (CE APPLICATIONS ONLY)

035-21476-000
 SHT. 7 OF 11
 REV B



* THESE PINS ARE CONNECTED TO CIRCUIT 14 ON SYSTEM WIRING SIDE FOR K7 COMPR. ONLY

LD12887a

FIGURE 9 - CONNECTION DIAGRAM (CE) (CONT'D)

CONNECTION DIAGRAM (CONT'D)

035-21476-000
 SHT. 8 OF 11
 REV B

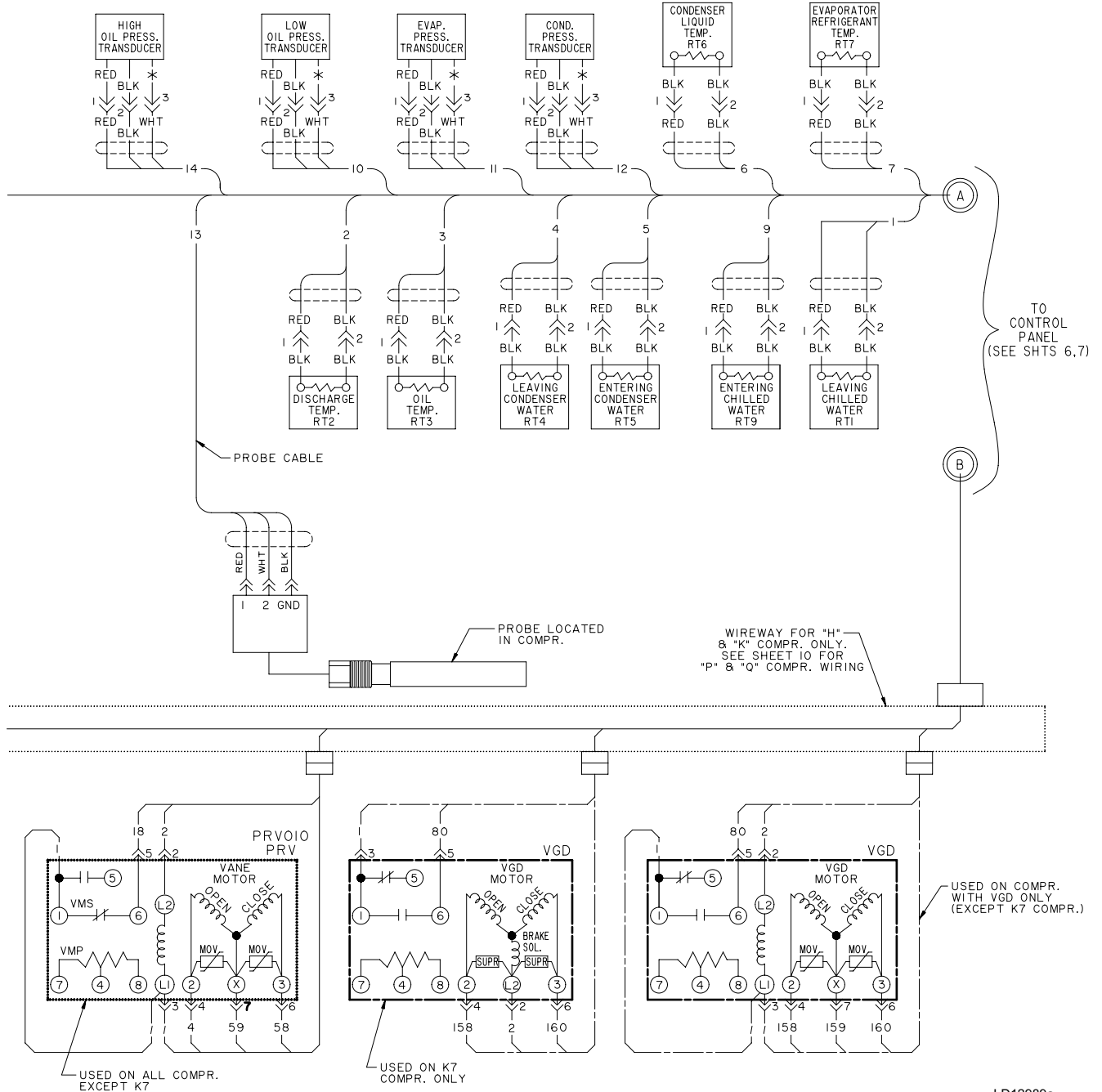
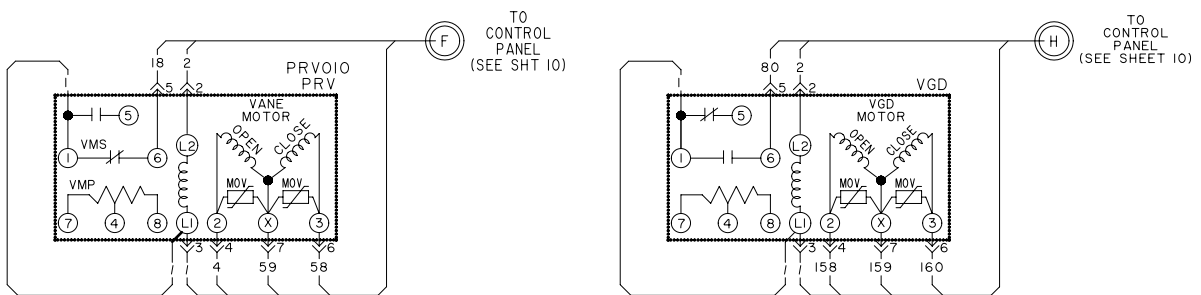
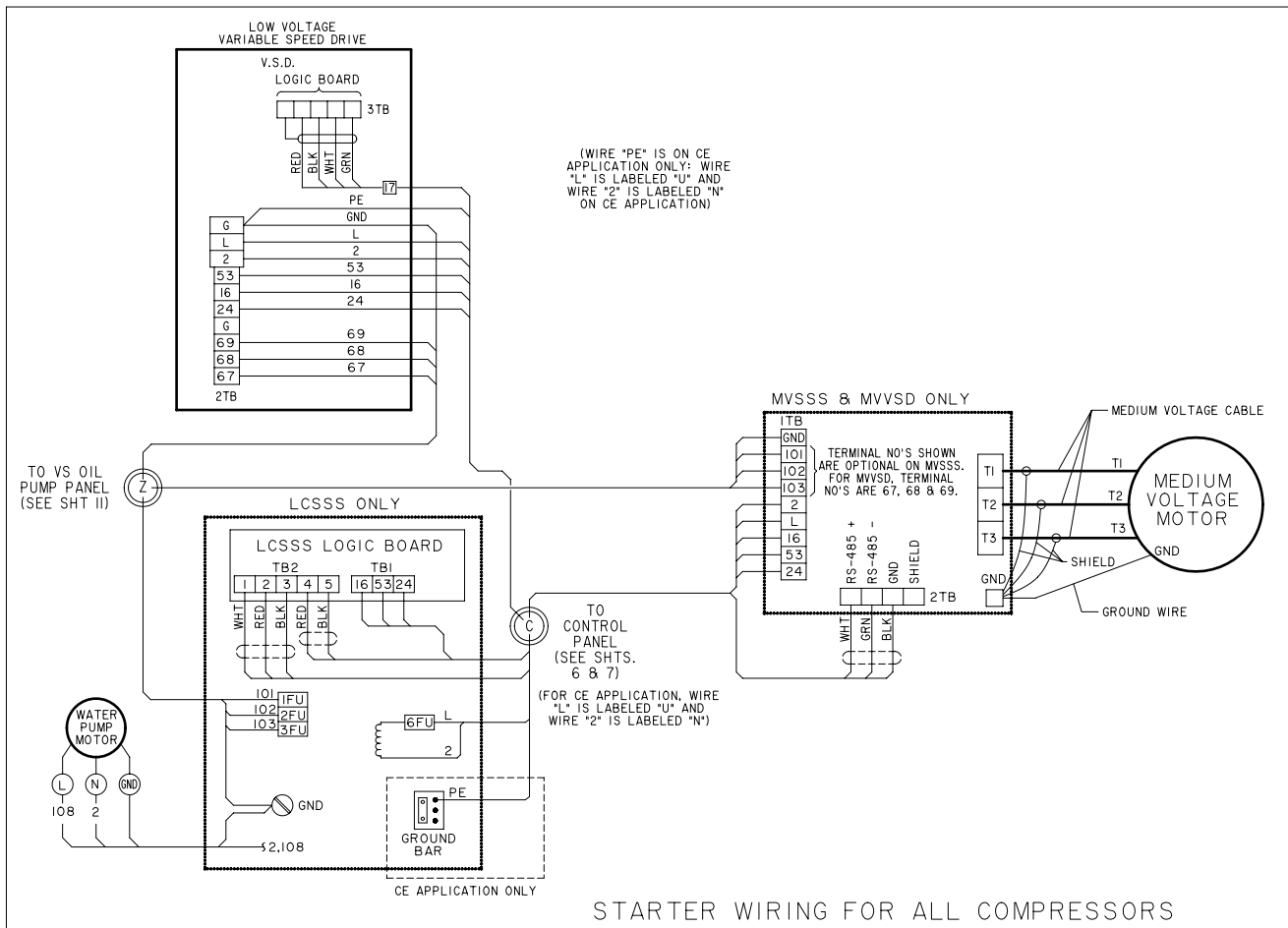

FIGURE 10 - CONNECTION DIAGRAM (CONT'D)

CONNECTION DIAGRAM

035-21476-000
 SHT. 9 OF 11
 REV B



LD11997a

FIGURE 11 - CONNECTION DIAGRAM

CONNECTION DIAGRAM (CONT'D)

035-21476-000
 SHT. 9 OF 11
 REV B

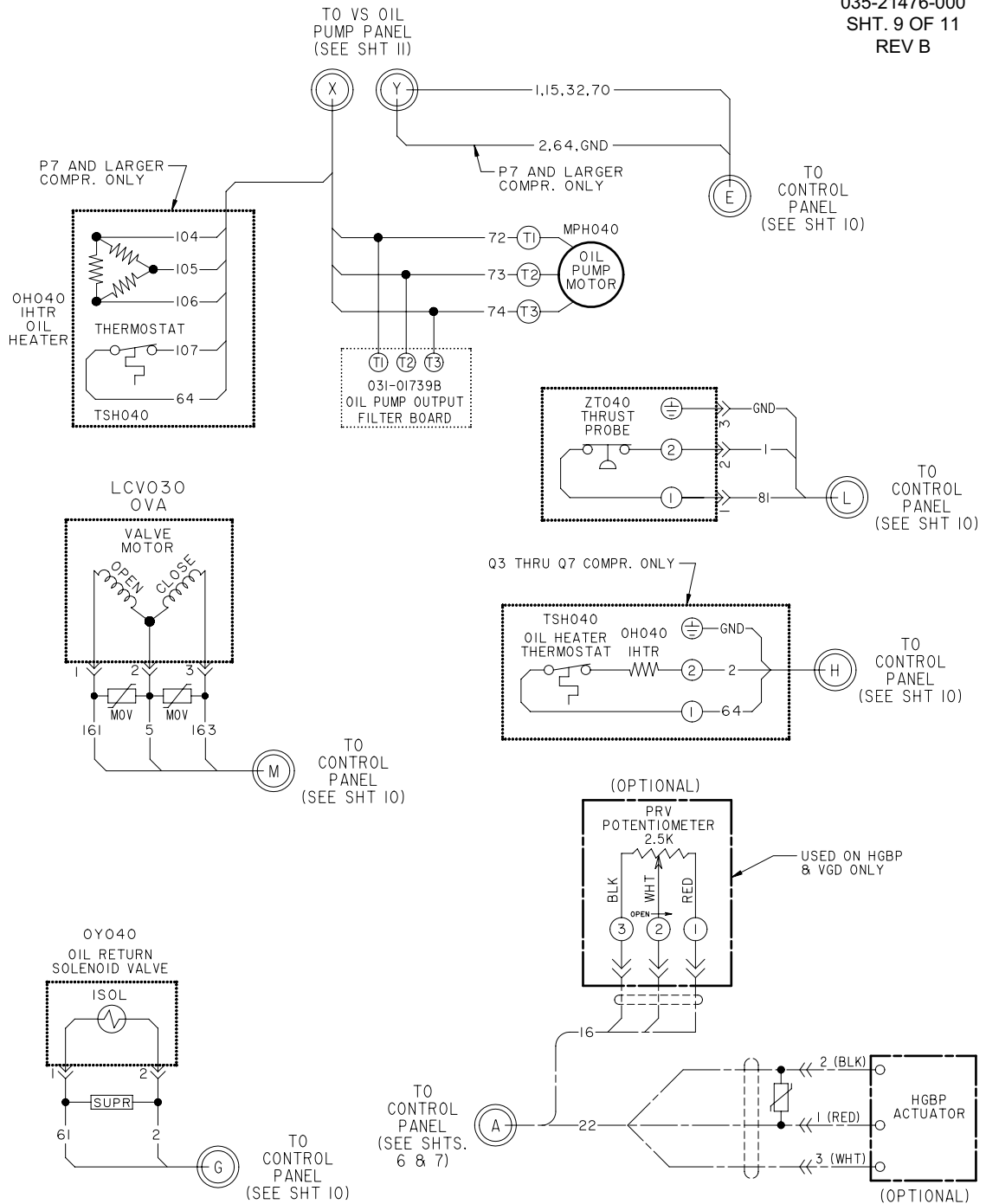

LD11998a

FIGURE 11 - CONNECTION DIAGRAM (CONT'D)

CONNECTION DIAGRAM

035-21476-000
 SHT. 10 OF 11
 REV B

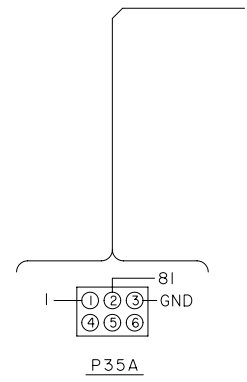
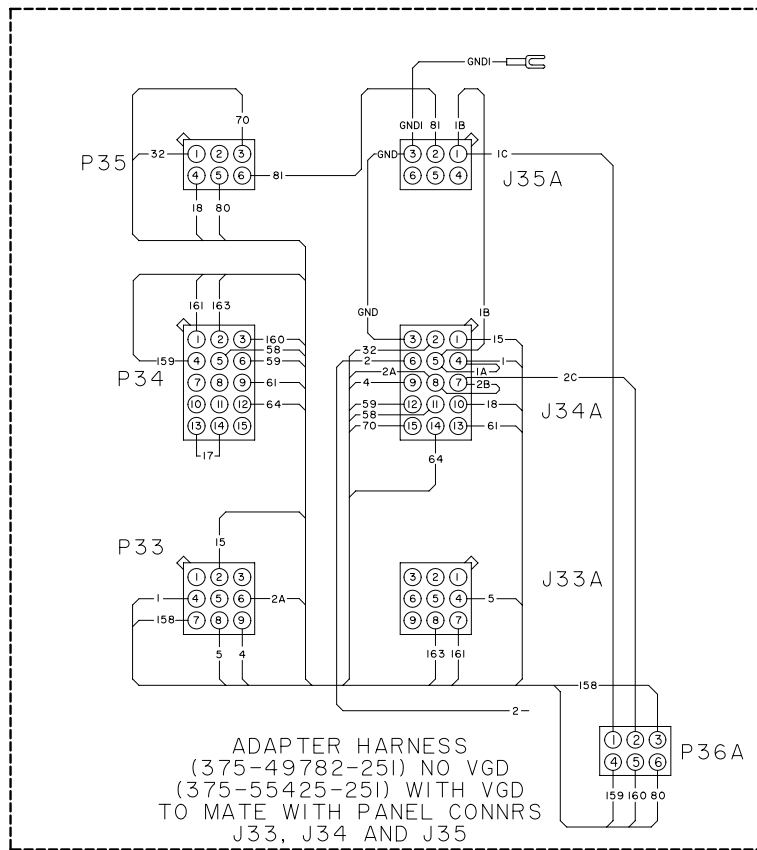

WIRE ENTRY VIEW
 Q3 THRU Q7 COMPR.

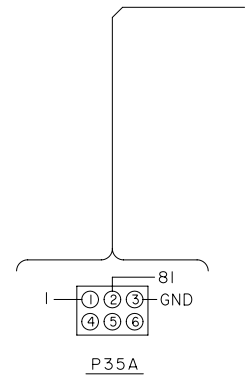

WIRE ENTRY VIEW
 P8 AND P9 COMPR.

LD12993a

FIGURE 12 - CONNECTION DIAGRAM

CONNECTION DIAGRAM (CONT'D)

035-21476-000
 SHT. 10 OF 11
 REV B

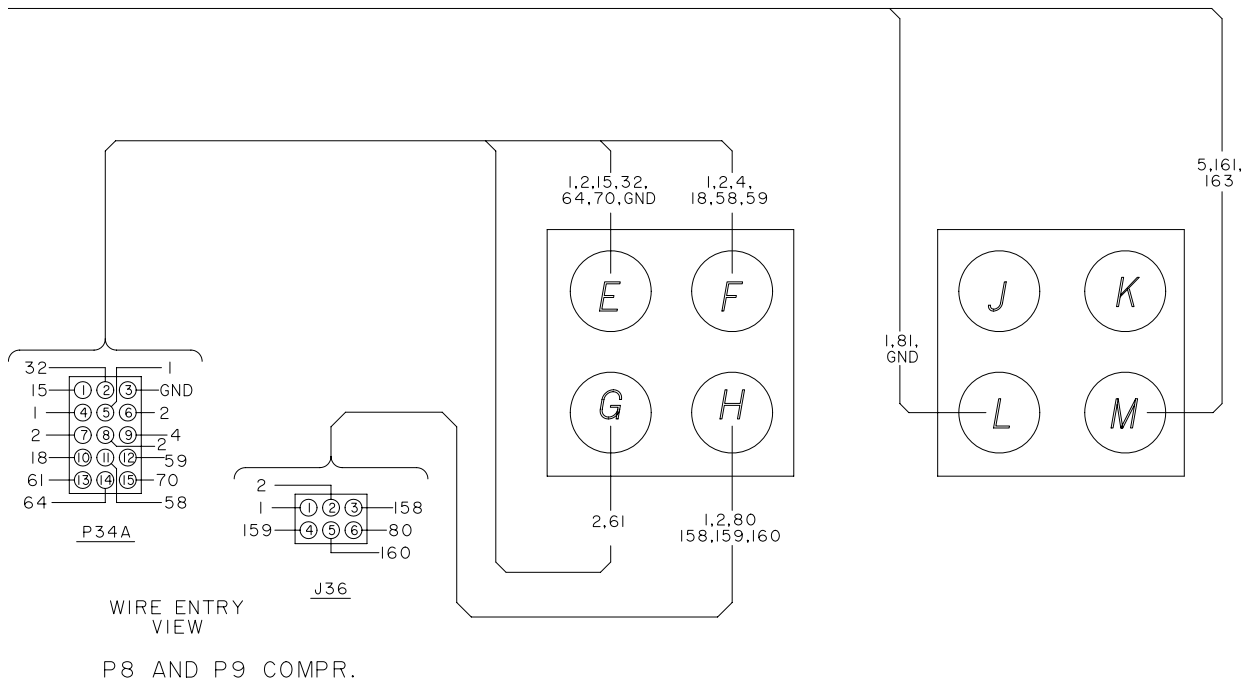
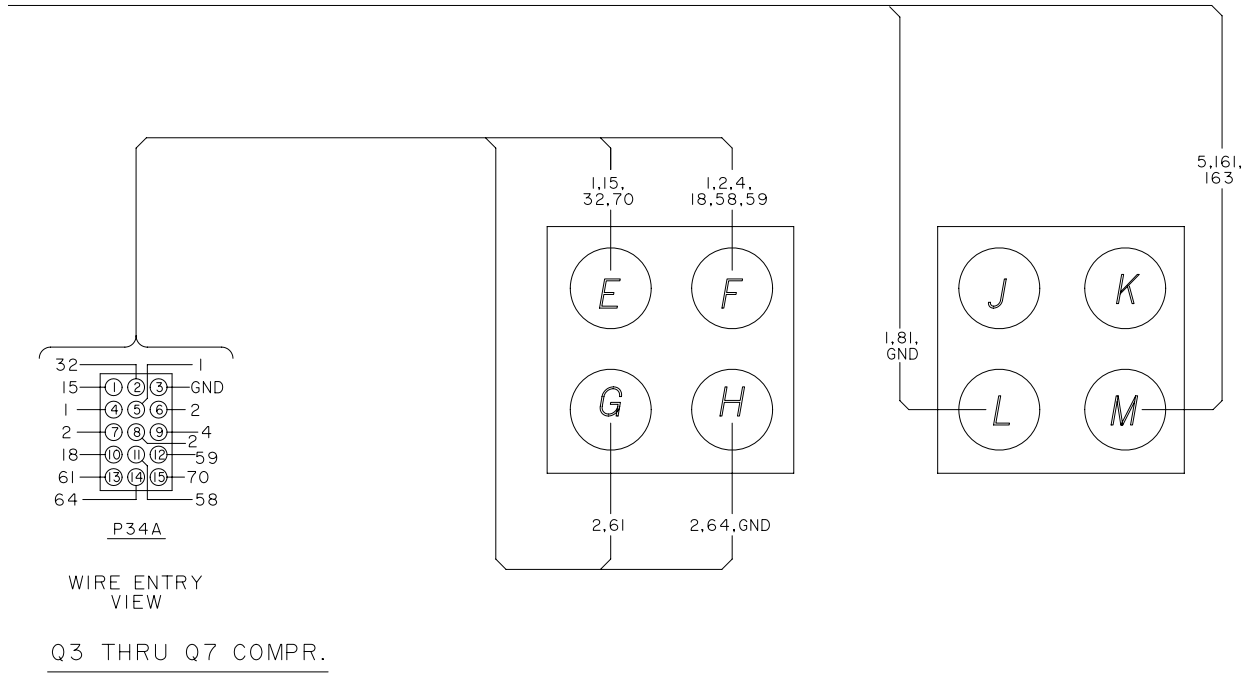

LD12992a

FIGURE 12 - CONNECTION DIAGRAM (CONT'D)

VARIABLE SPEED OIL PUMP DRIVE PANEL

WIRING FOR 200 THRU 240V
 AND 380 THRU 480V UNITS

035-21476-000
 SHT. 11 OF 11
 REV B

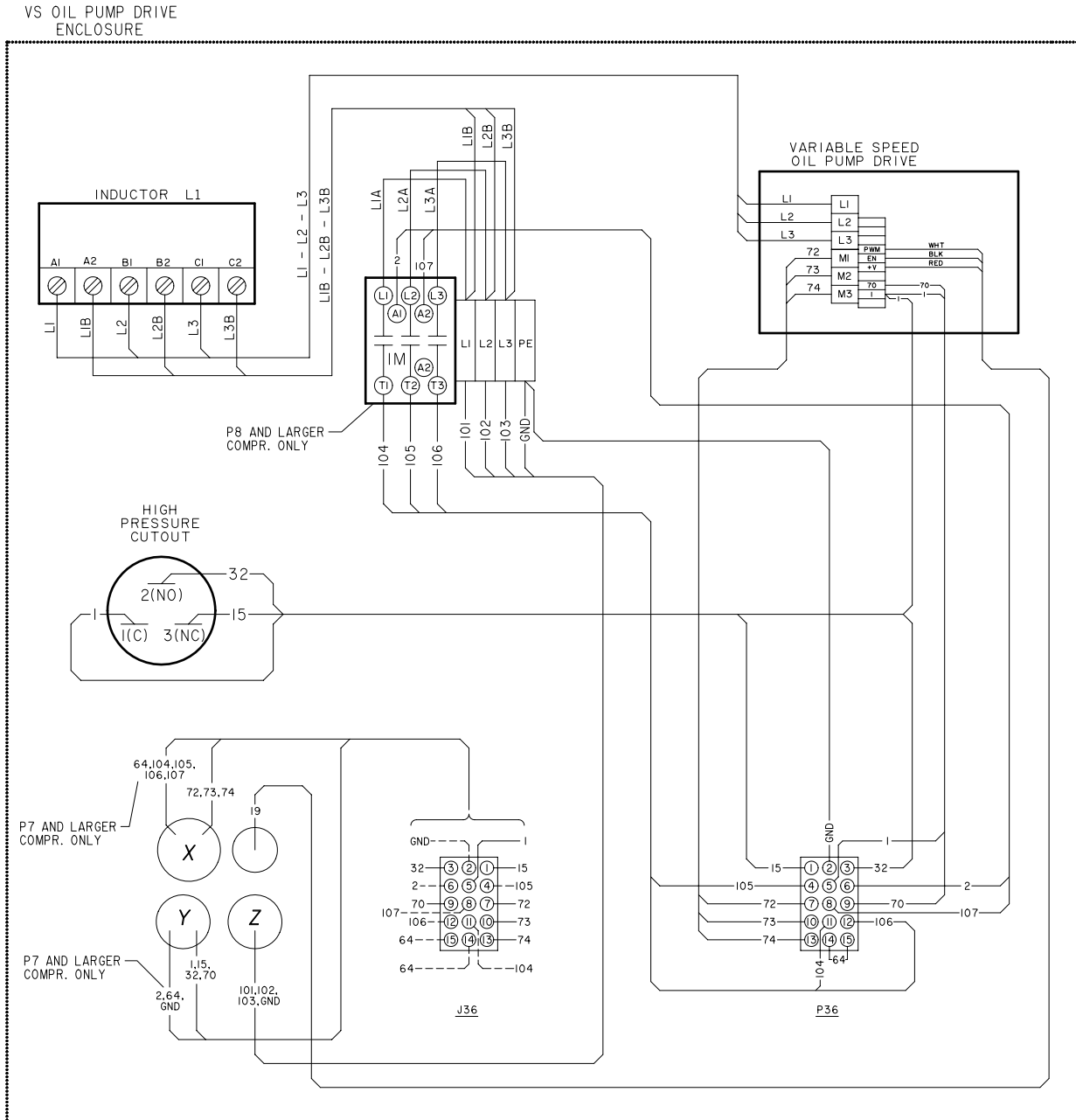

LD12968a

FIGURE 13 - VARIABLE SPEED OIL PUMP DRIVE PANEL (200-240 AND 380-480V)

VARIABLE SPEED OIL PUMP DRIVE PANEL (CONT'D)

WIRING FOR 346V AND
 550 THRU 600V UNITS

035-21476-000
 SHT. 11 OF 11
 REV B

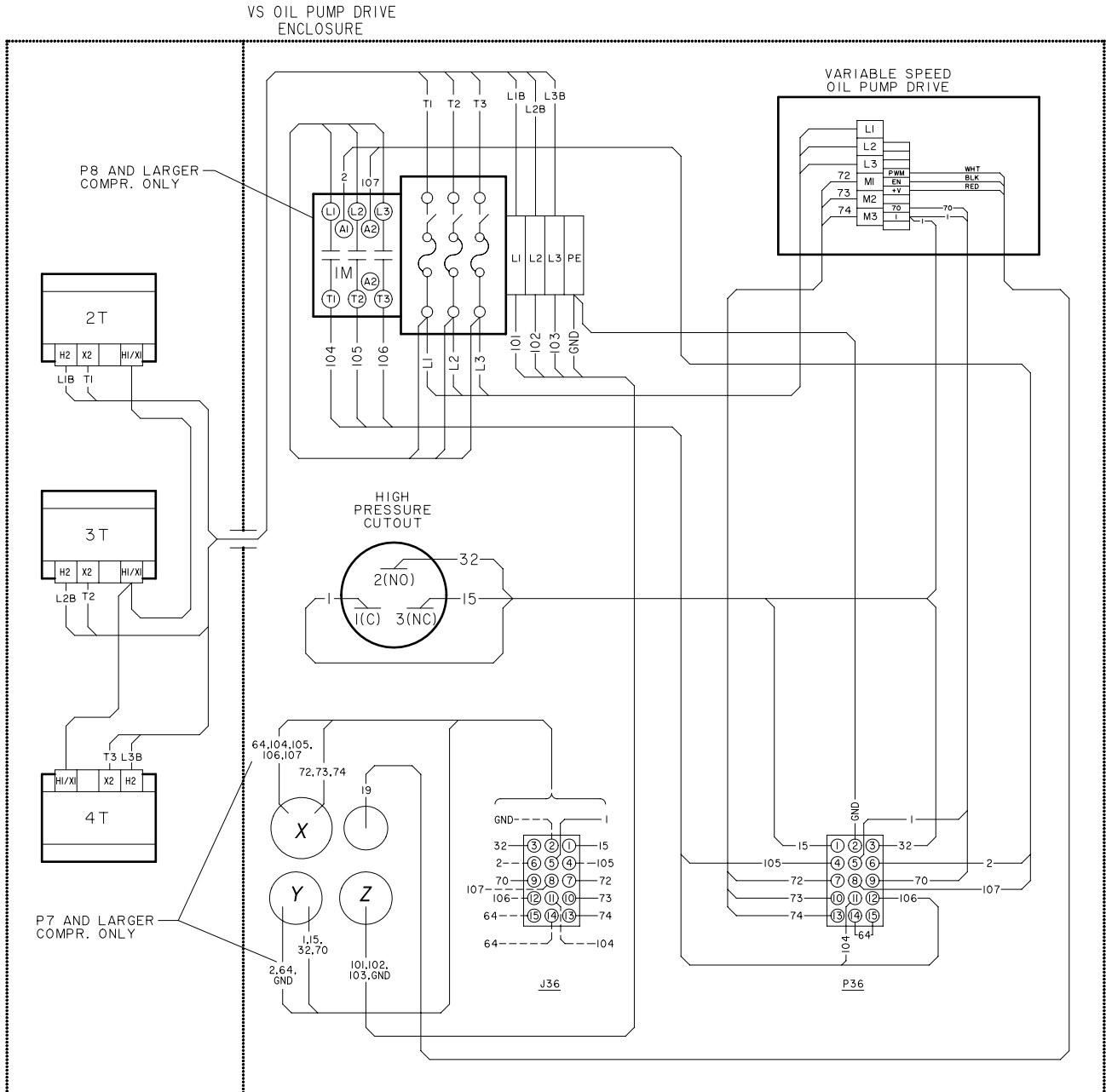

LD12969a

FIGURE 13 - VARIABLE SPEED OIL PUMP DRIVE PANEL (346 AND 550-600V) (CONT'D)



P.O. Box 1592, York, Pennsylvania USA 17405-1592

Copyright © by Johnson Controls 2013

Form 160.75-PW6 (1013)

Issue Date: October 4, 2013

Supersedes 160.75-PW6 (311)

800-861-1001

www.johnsoncontrols.com

Subject to change without notice. Printed in USA

ALL RIGHTS RESERVED