

MODEL YK CENTRIFUGAL LIQUID CHILLERS STYLE G

250 THROUGH 3000 TONS
(879 through 10,500 kW)
Utilizing HFC-134a

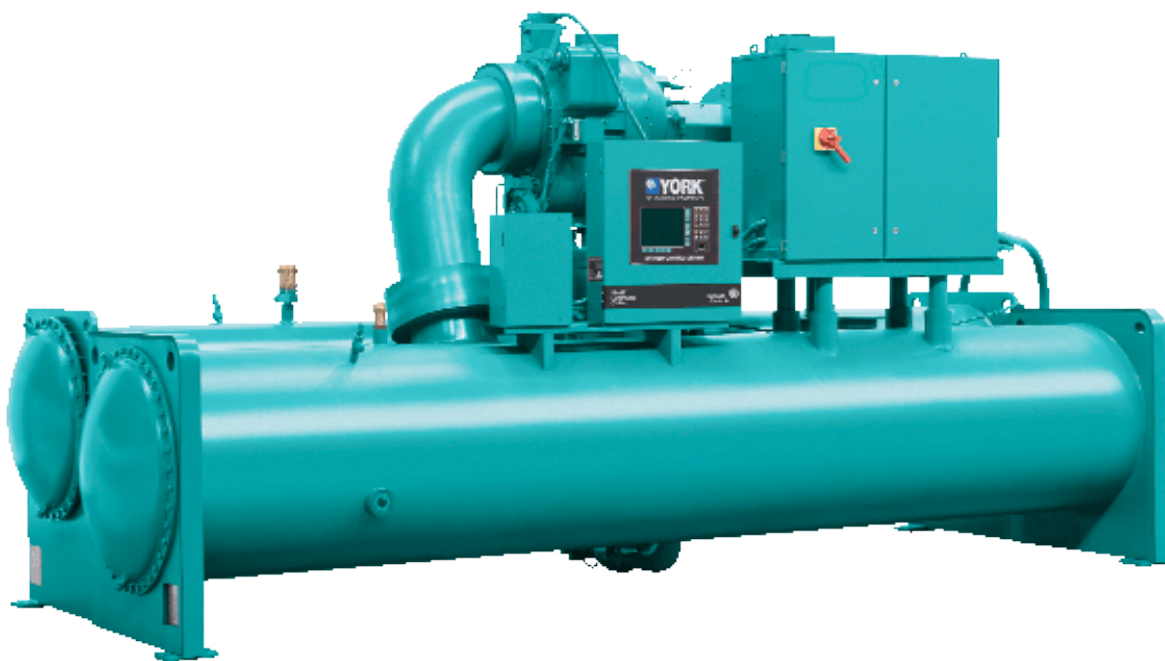

BY JOHNSON CONTROLS

Nomenclature

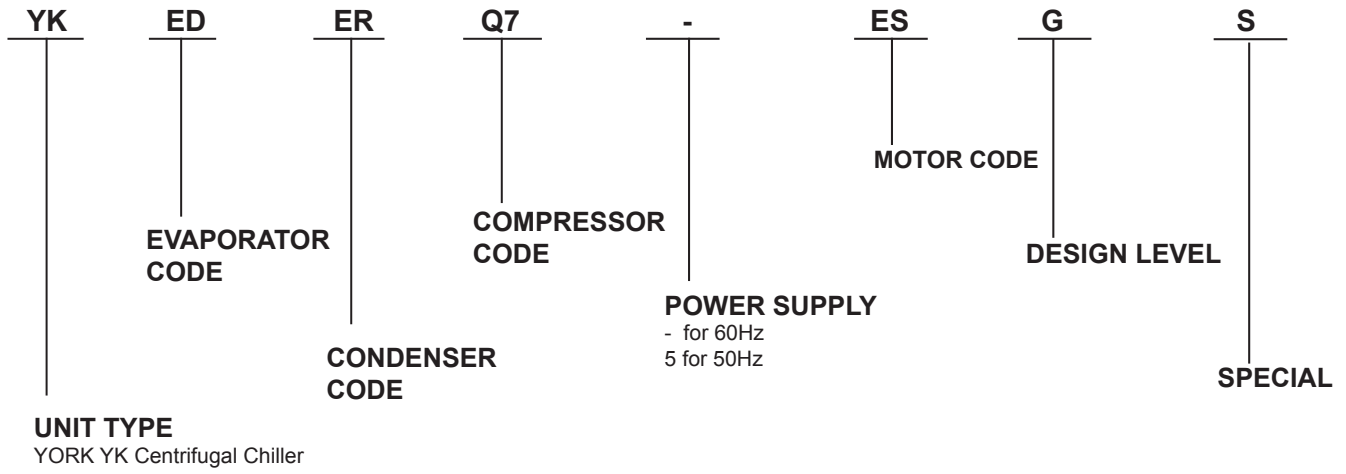

Approvals

See *CODES AND STANDARDS* on page 21

Table Of Contents

INTRODUCTION	5
SUSTAINABILITY FOCUS	9
EQUIPMENT OVERVIEW	13
OPTIVIEW CONTROL CENTER	24
ACCESSORIES AND MODIFICATIONS	42
APPLICATION DATA	54
DIMENSIONS	84
WEIGHTS	108
GUIDE SPECIFICATIONS	110
SI METRIC CONVERSION	123

THIS PAGE INTENTIONALLY LEFT BLANK.

Introduction

The YORK YK Chillers, manufactured by Johnson Controls, offer a complete combination of features for total owner satisfaction.

MATCHED COMPONENTS MAXIMIZE EFFICIENCY

Actual chiller efficiency cannot be determined by analyzing the theoretical efficiency of any one chiller component. It requires a specific combination of heat exchanger, compressor, and motor performance to achieve the lowest system kW/ton. YORK chiller technology matches chiller system components to provide maximum chiller efficiency under actual – not just theoretical – operating conditions.

REAL-WORLD ENERGY PERFORMANCE

Johnson Controls pioneered the concept of “Real-World Energy” to illustrate the energy-saving potential of focusing on chiller performance during off-design conditions. Off-design is not only part load, but full load operation as well, with reduced entering condenser water temperatures (ECWTs). This is where chillers operate 99% of the time, and where operating costs add up.

The YORK YK chillers are the only chillers designed to operate on a continuous basis with cold ECWT and full condenser flow at all load points, taking full advantage of Real-World conditions. This type of operation benefits the cooling tower as well by reducing the cycling of the fan motor and ensuring good coverage of the cooling fill.

YORK YK chillers offer the most efficient Real-World operation of any chiller, meaning lower operating costs and an excellent return on your chiller investment.

OPEN-DRIVE DESIGN

Hermetic motor burnout can cause catastrophic damage to a chiller. The entire chiller must be cleaned, and the refrigerant replaced. YORK YK centrifugal chillers eliminate this risk by utilizing air-cooled motors. Refrigerant never comes in contact with the motor, preventing contamination of the rest of the chiller.

Insurance companies that offer policies on large air conditioning equipment often consider air-cooled motors a significant advantage over hermetic refrigerant-cooled units.

HIGH EFFICIENCY HEAT EXCHANGERS

YORK YK chiller heat exchangers offer the latest technology in heat transfer surface design to give you maximum efficiency and compact design. Waterside and refrigerant side design enhancements minimize both energy consumption and tube fouling.

Introduction (Cont'd)

SINGLE STAGE COMPRESSOR DESIGN AND EFFICIENCY PROVEN IN THE MOST DEMANDING APPLICATIONS

Designed to be the most reliable chillers we've ever made, YORK YK centrifugal chillers incorporate single-stage compressor design. With fewer moving parts and straight-forward, efficient engineering, YORK single-stage compressors have proven durability records in hospitals, chemical plants, gas processing plants, the U.S. Navy, and in other applications where minimal downtime is a crucial concern.

In thousands of installations worldwide, YORK single-stage compressors are working to reduce energy costs. High strength aluminum-alloy compressor impellers feature backward curved vanes for high efficiency. Airfoil shaped pre rotation vanes minimize flow disruption for the most efficient part load performance. Precisely positioned and tightly fitted, they allow the compressor to unload smoothly from 100% to minimum load for excellent operation in air conditioning applications.

PRECISION CONTROL OF COMPRESSOR OIL PRESSURE

Utilizing our expertise in variable speed drive technology and applications, Johnson Controls has moved beyond the fixed head and bypass approach of oil pressure control. The old approach only assures oil pressure at the outlet of the pump rather than at the compressor, and allows no adjustment during chiller operation. The YORK YK chillers feature a variable speed drive oil pump, monitoring and providing the right amount of oil flow to the compressor on a continuous basis. This design also provides sophisticated electronic monitoring and protection of the oil pump electrical supply, ensuring long life and reliable operation of the oil pump motor. Variable speed drive technology reduces oil pump power consumption, running only at the speed required, rather than at full head with a pressure regulating bypass valve.

FACTORY PACKAGING REDUCES FIELD LABOR COSTS

YORK YK centrifugal chillers are designed to keep installation costs low. Where installation access is not a problem, the unit can be shipped completely packaged, requiring minimal piping and wiring to complete the installation.

For those units utilizing Variable Speed Drive or a factory-installed Solid-State Starter, the three power leads provide all power to the chiller and its auxiliaries.

AHRI CERTIFICATION PROGRAM

YORK YK chillers have been tested and certified by Air-Conditioning, Heating and Refrigeration Institute (AHRI) in accordance with the latest edition of AHRI Standard 550/590 (I-P). Under this Certification Program, chillers are regularly tested in strict compliance with this Standard. This provides an independent, third-party verification of chiller performance. Refer to the AHRI site at: http://www.ahrinet.org/water_chilling+packages+using+vapor+compression+cycle+_water_cooled_.aspx for complete Program Scope, Inclusions, and Exclusions as some options listed herein fall outside the scope of the AHRI certification program. For verification of certification, go to the AHRI Directory at www.ahridirectory.org.

Introduction (Cont'd)



TAKE ADVANTAGE OF COLDER COOLING TOWER WATER TEMPERATURES

YORK YK centrifugal chillers have been designed to take full advantage of colder cooling tower water temperatures, which are naturally available during most operating hours. Considerable energy savings are available by letting tower water temperature drop, rather than artificially holding it above 75°F (23.9°C), especially at low load, as some chillers require.

UL COMPLIANCE – YOUR ASSURANCE OF RELIABILITY

YORK YK centrifugal chillers are approved to UL Standard 1995 for listing by a qualified nationally recognized testing laboratory for the United States and Canada. Recognition of safety and reliability is your assurance of trouble free performance in day to-day building operation.

Some chiller options or modifications may affect the UL compliance of the chiller. Some examples include: special motor enclosures (like TEFC, TEWAC, or TEAAC) or special panels (NEMA 4X) or special unit wiring options (anything other than NEMA 1). For further clarification, contact Johnson Controls Large Tonnage Marketing.

COMPUTERIZED PERFORMANCE RATINGS

Each chiller is custom matched to meet the individual building load and energy requirements. A large number of standard heat exchangers and pass arrangements are available to provide the best possible match.

It is not practical to provide tabulated performance for each combination, as the energy requirements at both full and part load vary significantly with each heat exchanger and pass arrangement. Computerized ratings are available through each Johnson Controls Sales Office. These ratings can be tailored to specific job requirements, and are part of the AHRI Certification Program.

OFF-DESIGN PERFORMANCE

Since the vast majority of its operating hours are spent at off design conditions, a chiller should be chosen not only to meet the full load design, but also for its ability to perform efficiently at lower loads and lower tower water temperatures. It is not uncommon for chillers with the same full load kW/ton to have an operating cost difference of over 10% due to part load operation.

Introduction (Cont'd)

Part load information can be easily and accurately generated by use of the computer. And because it is so important to an owner's operating budget, this information has now been standardized within the AHRI Certification Program in the form of an Integrated Part Load Value (IPLV), and Non-Standard Part Load Value (NPLV).

The IPLV/NPLV formulas from AHRI Standard 550/590 much more closely track actual chiller operations, and provide a more accurate indication of chiller performance than the previous IPLV/APLV formula. A more detailed analysis must take into account actual building load profiles, and local weather data. Part load performance data should be obtained for each job using its own design criteria.

Sustainability Focus

OZONE-DEPLETION POTENTIAL (ODP)

The YORK YK chiller employs one the most environmentally friendly refrigerants available today, HFC-134a, with no Ozone Depletion Potential (ODP) and no phase out date per the Montreal Protocol.

Ozone is a very small part of the atmosphere, but its presence is nevertheless vital to human well-being. Most ozone resides in the upper part of the atmosphere. This region, called the stratosphere, is more than 10 kilometers (6 miles) above the Earth's surface. There, about 90% of atmospheric ozone is contained in the "ozone layer," which shields us from harmful ultraviolet radiation from the sun. However, it was discovered in the mid-1970s that some human-produced chemicals could destroy ozone and deplete the ozone layer. The resulting increase in ultraviolet radiation at the Earth's surface may increase the incidences of skin cancer and eye cataracts. Following the discovery of this environmental issue, researchers focused on gaining a better understanding of this threat to the ozone layer.

REFRIGERANT		COMMON USE	ODP	GWP	STATUS	2007 GLOBAL USAGE (TONS)
CFC	CFC-11	Centrifugals	1.00	5000	Phased Out	Trace
	CFC-12	Centrifugals	0.80	8500	Phased Out	Trace
HCFC	HCFC-22	Scrolls, Screws, Unitary products	0.05	1700	Phasing Out	700,000
	HCFC-123	Centrifugals	0.02	120	Phasing Out	4,000
HFC	HFC-134a	Centrifugals, Screws	-	1300	No Phase Out	250,000
	HFC-407c	Screws, Scrolls	-	1600	No Phase Out	100,000
	HFC-410A	Scrolls, Unitary products	-	1890	No Phase Out	
	HFC-404A		-	3750	No Phase Out	
	HFC-245fa	Centrifugals	-	1020	No Phase Out	Trace
HFO	HFO-1234yf	Centrifugals	-	4	No Phase Out	New
HC (Natural Refr.)	HC-717 (NH3)	Screws, Centrifugals	-	1	No Phase Out	
	HC-718 (water)	Absorption, Vapor Compression	-	0	No Phase Out	
	HC-290 (propane)		-	3	No Phase Out	
	HC-600a (butane)		-	3	No Phase Out	
	HC-744 (CO2)		-	1	No Phase Out	

Sustainability Focus (Cont'd)

Monitoring stations showed that ozone-depleting chemicals were steadily increasing in the atmosphere. These trends were linked to growing production and use of chemicals like chlorofluorocarbons (CFCs) for refrigeration and air conditioning, foam blowing, and industrial cleaning. Measurements in the laboratory and the atmosphere characterized the chemical reactions that were involved in ozone destruction. Computer models employing this information could predict how much ozone depletion was occurring and how much more could occur in the future.

Observations of the ozone layer showed that depletion was indeed occurring. The most severe and most surprising ozone loss was discovered to be recurring in springtime over Antarctica. The loss in this region is commonly called the “ozone hole” because the ozone depletion is so large and localized. A thinning of the ozone layer also has been observed over other regions of the globe, such as the Arctic and northern middle latitudes. The work of many scientists throughout the world has provided a basis for building a broad and solid scientific understanding of the ozone depletion process. With this understanding, we know that ozone depletion is occurring and why. And, most important, we know that if ozone-depleting gases were to continue to accumulate in the atmosphere, the result would be more depletion of the ozone layer. In response to the prospect of increasing ozone depletion, the governments of the world crafted the 1987 United Nations Montreal Protocol as a global means to address this global issue. As a result of the broad compliance with the Protocol and its Amendments and Adjustments and, of great significance, industry’s development of “ozone friendly” substitutes for the now-controlled chemicals, the total global accumulation of ozone-depleting gases has slowed and begun to decrease. This has reduced the risk of further ozone depletion.

THE MONTREAL PROTOCOL ADDRESSED CFC’S AND HCFC’S

The Montreal Protocol (MP) addressed CFC’s and HCFC’s with phase out schedule for all member parties of the MP based on the ODP characteristics. So this affects the first two categories of refrigerants listed in the table. Manufacturers in developed nations are in the final processes of converting from HCFC’s to HFC’s in accordance with the Montreal Protocol treaty. Markets in developing countries are already seeing a transition away from HCFC’s ahead of legislative requirements.

HCFC’s were used as a transitional refrigerant as they were a “Lesser Evil” and allowed the HVAC industry to quickly transition away from CFCs while maintaining energy efficiency. The fact remains that they destroy the ozone layer and are legislated to be completely phased out.

The Montreal Protocol does not extend to HFC’s as they have no ODP nor does it extend to natural refrigerants for the same reason.

The typical usage of the refrigerant, the phase-out status by the Montreal Protocol and the global usage of refrigerant in tons is shown in the table on page 9.

Sustainability Focus (Cont'd)

The chart below shows the growing use of HFC-134a in centrifugal chillers from 1995 up to 2010 and the forecast until the phase-out of HCFC's.

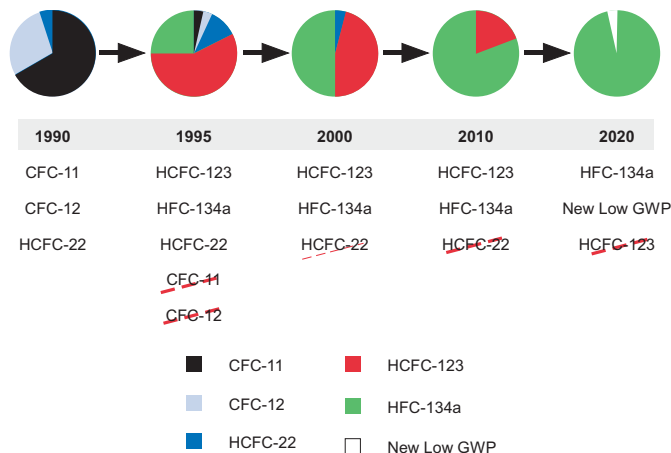

GLOBAL WARMING POTENTIAL (GWP)

Another main environmental topic is Global Warming potential (GWP), and when we talk about global warming we're primarily talking about smoke stacks and tail pipes. 85% of GWP is attributed to CO₂ emissions, while only about 2% is related to HFC's.

However, when we talk about the direct impact our YORK YK Centrifugal Chiller has on the environment we can make strides forward, like ensuring leak tight designs are created, and manufacturers are working to reduce refrigerant charges as much as possible.

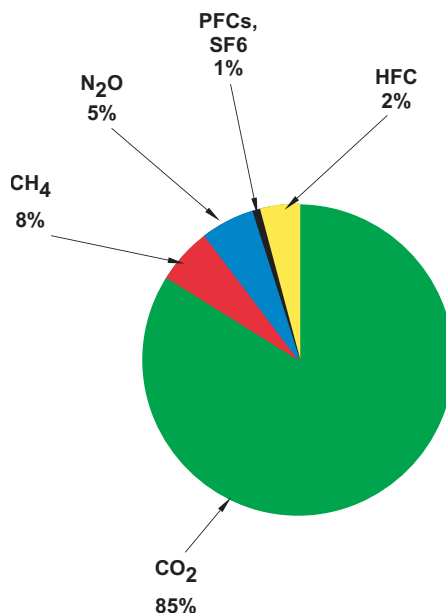

Sustainability Focus (Cont'd)

DIRECT & INDIRECT GLOBAL WARMING POTENTIAL

98% of the global warming potential of a centrifugal chiller is from the indirect effect or the greenhouse gases produced to generate the electricity to run the chiller. The YORK YK centrifugal chiller and its superior efficiency levels dramatically reduces the indirect GWP. Two percent of the GWP is from the direct effect or release of the refrigerant gases into the atmosphere.

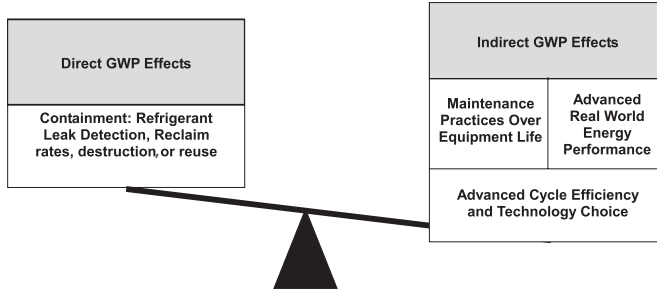

Minimizing the total climatic impact (direct and indirect GWP) requires a comprehensive approach to refrigerant choice.

Equipment Overview

YORK YK chillers are completely factory-packaged including the evaporator, condenser, compressor, motor, lubrication system, control center, and all interconnecting unit piping and wiring.

The initial charge of refrigerant and oil is supplied for each chiller. When the optional condenser isolation valves are ordered, most units may ship fully charged with refrigerant and oil. Actual shipping procedures will depend on a number of project-specific details.

The services of a Johnson Controls factory-trained, field service representative are incurred to supervise or perform the final leak testing, charging, the initial start-up, and concurrent operator instructions.

COMPRESSOR

The compressor is a single stage centrifugal type powered by an open drive electric motor. The casing is fully accessible with vertical circular joints and fabricated of close grain cast iron. The complete operating assembly is removable from the compressor and scroll housing.

The rotor assembly consists of a heat treated alloy steel drive shaft and impeller shaft with a high strength, cast aluminum alloy, fully shrouded impeller. The impeller is designed for balanced thrust and is dynamically balanced and overspeed tested for smooth, vibration free operation.

The insert-type journal and thrust bearings are fabricated of aluminum alloy and are precision bored and axially grooved. The specially engineered, single helical gears with crowned teeth are designed so that more than one tooth is in contact at all times to provide even distribution of compressor load and quiet operation. Gears are assembled as part of the compressor rotor support and are film lubricated. Each gear is individually mounted in its own journal and thrust bearings to isolate it from impeller and motor forces.

CAPACITY CONTROL

Pre-rotation vanes (PRV) modulate chiller capacity from 100% to 15% of design for normal air conditioning applications. Operation is by an external, electric PRV actuator which automatically controls the vane position to maintain a constant leaving chilled liquid temperature. Rugged airfoil-shaped, cast-manganese-bronze vanes are precisely positioned by solid vane linkages connected to the electric actuator.

LUBRICATION SYSTEM

Lubrication oil is force-fed to all bearings, gears and rotating surfaces by a variable speed drive pump which operates prior to startup, continuously during operation and during coastdown. A gravity fed oil reservoir is built into the top of the compressor to provide lubrication during coastdown in the event of a power failure.

An oil reservoir, separate from the compressor, contains the submersible oil pump, 2 HP (1.5 kW) pump motor and 3000 watt immersion type oil heater. The oil heater is thermostatically controlled to remove refrigerant from the oil.

Equipment Overview (Cont'd)

Oil is filtered by an externally mounted 1/2 micron replaceable cartridge oil filter equipped with service valves. Oil is cooled via a refrigerant-cooled oil cooler, eliminating the requirement for field water piping. The oil side of the oil cooler is provided with service valves. An automatic oil return system recovers any oil that may have migrated to the evaporator. Oil piping is completely factory-installed.

WATER-COOLED OIL COOLER

Optional condenser water-cooled oil cooler is offered for units with Q3 compressors C-D shells only. This oil cooler is a shell and tube heat exchanger. Water from condenser supply waterbox circulates through the tube side of the heat exchanger and discharges back into the return side of the waterbox. Hot oil circulates through the tubes within the oil cooler, and is cooled by the cold condenser water. The cooled oil is then sent back to the compressor through a temperature regulator valve and oil filters. Both the oil and water piping are completely factory-installed, eliminating the requirement for field piping.

MOTOR DRIVELINE

The compressor motor is an open drip proof, squirrel cage, induction type constructed to YORK design specifications. The 60 hertz motors operate at 3570 rpm and the 50 hertz motors operate at 2975 rpm.

The open motor is provided with a D flange, and is factory-mounted to a cast iron adaptor mounted on the compressor. This unique design allows the motor to be rigidly coupled to the compressor to provide factory alignment of motor and compressor shafts.

Motor drive shaft is directly connected to the compressor shaft with a flexible disc coupling. Coupling has all metal construction with no wearing parts to assure long life, and no lubrication requirements to provide low maintenance.

For units utilizing remote electro mechanical starters, a large, steel terminal box with gasketed front access cover is provided for field-connected conduit. There are six terminals (three for medium voltage) brought through the motor casing into the terminal box. Jumpers are furnished for three-lead types of starting. Motor terminal lugs are not furnished. Overload/over-current transformers are furnished with all units. For units furnished with factory-packaged Solid-State Starters or Variable Speed Drive, refer to the Accessories and Modifications Section.

HEAT EXCHANGERS

Shells

Evaporator and condenser shells are fabricated from rolled carbon steel plates with fusion welded seams or carbon steel pipe. Carbon steel tube sheets, drilled and reamed to accommodate the tubes, are welded to the end of each shell. Intermediate tube supports are fabricated from carbon steel plates, drilled and reamed to eliminate sharp edges, and spaced no more than four feet apart. The refrigerant side of each shell is designed, tested, and stamped in accordance with ASME Boiler and Pressure Vessel Code, Section VIII – Division I, or other pressure vessel code as appropriate.

Equipment Overview (Cont'd)

Tubes

Heat exchanger tubes are state-of-the-art, high-efficiency, externally and internally enhanced type to provide optimum performance. Tubes in both the evaporator and condenser are 3/4" (19 mm) O.D. standard [or 1" (25.4 mm) optional in some shells] copper alloy and utilize the "skip-fin" design, providing a smooth internal and external surface at each intermediate tube support. This provides extra wall thickness (up to twice as thick) and non work-hardened copper at the support location, extending the life of the heat exchangers. Each tube is roller expanded into the tube sheets providing a leak-proof seal, and is individually replaceable.

Evaporator

The evaporator is a shell and tube type with customer process fluid flowing inside the tubes and refrigerant removing heat on the shell side via evaporation. Evaporator codes A_ thru Q_ utilize a hybrid falling film design. It contains a balance of flooded and falling film technology to optimize efficiency, minimize refrigerant charge, and maintain reliable control. A specifically designed spray distributor provides uniform distribution of refrigerant over the entire length to yield optimum heat transfer. The hybrid falling film evaporator design has suction baffles around the sides and above the falling film section to prevent liquid refrigerant carryover into the compressor.

Evaporator codes R_ thru Z_ are flooded type, with a liquid inlet distributor trough underneath the tube bundle. This provides uniform distribution of refrigerant over the entire shell length to yield optimum heat transfer. Flooded evaporator designs have an aluminum mesh eliminator on R_ thru Z_ shells located above the tube bundle to prevent liquid refrigerant carryover into the compressor.

A 1-1/2" (38 mm) liquid level sight glass is conveniently located on the side of the shell to aid in determining proper refrigerant charge. The evaporator shell contains a dual refrigerant relief valve arrangement set at 180 psig (12.4 barg) on H and K compressor models; 235 psig (16.2 barg) on P and Q compressor models; or single-relief valve arrangement, if the chiller is supplied with optional refrigerant isolation valves. A 1" (25.4 mm) refrigerant charging valve is provided.

Condenser

The condenser is a shell and tube type, with a discharge gas baffle to prevent direct high velocity impingement on the tubes. The baffle is also used to distribute the refrigerant gas flow properly for most efficient heat transfer. An optional cast steel condenser inlet diffuser may be offered, on "M" and larger condensers, in lieu of the baffle, to provide dynamic pressure recovery and enhanced chiller efficiency. An integral sub cooler is located at the bottom of the condenser shell providing highly effective liquid refrigerant subcooling to provide the highest cycle efficiency. The condenser contains dual refrigerant relief valves set at 235 psig (16.2 barg).

Waterboxes

The removable waterboxes are fabricated of steel. The design working pressure is 150 psig (10.3 barg) and the boxes are tested at 225 psig (15.5 barg). Integral steel water baffles are located and welded within the waterbox to provide the required pass arrangements. Stub out water nozzle connections with ANSI/AWWA C-606 grooves are welded to the waterboxes. These nozzle connections are suitable for ANSI/AWWA C-606 couplings, welding or flanges, and are capped for shipment. Plugged 3/4" (19 mm) drain and vent connections are provided in each waterbox.

Equipment Overview (Cont'd)

WATER FLOW SWITCHES

Thermal type water flow switches are factory mounted in the chilled and condenser water nozzles, and are factory wired to the OptiView control panel. These solid-state flow sensors have a small internal heating-element. They use the cooling effect of the flowing fluid to sense when an adequate flow rate has been established. The sealed sensor probe is 316 stainless steel, which is suited to very high working pressures.

OPTIVIEW CONTROL CENTER

The chiller is controlled by a stand-alone microprocessor based control center. The chiller control panel provides control of chiller operation and monitoring of chiller sensors, actuators, relays and switches.

Control Panel

The control panel includes a 10.4-in. (264 mm) diagonal color liquid crystal display (LCD) surrounded by "soft" keys which are redefined based on the screen displayed at that time, mounted in the middle of a keypad interface and installed in a locked enclosure. The screen details all operations and parameters, using a graphical representation of the chiller and its major components. Panel verbiage is available in eight languages and can be changed on the fly without having to turn off the chiller. Data can be displayed in either English or Metric units. Smart Freeze Point Protection will run the chiller at 36°F (2.2°C) leaving chilled water temperature, and not have nuisance trips on low water temperature. The sophisticated program and sensor monitors the chiller water temperature to prevent freeze-up. When needed, Hot Gas Bypass is available as an option. The panel displays countdown timer messages so the operator knows when functions are starting and stopping. Every programmable point has a pop-up screen with the allowable ranges, so that the chiller cannot be programmed to operate outside of its design limits.

The chiller control panel also provides:

A. System operating information including:

1. Return and leaving chilled water temperature
2. Return and leaving condenser water temperature
3. Evaporator and condenser saturation pressure
4. Differential oil pressure
5. Percent motor current
6. Evaporator and condenser saturation temperature
7. Compressor discharge temperature
8. Oil reservoir temperature
9. Compressor thrust bearing positioning (K compressors only)
10. Operating hours
11. Number of compressor starts

Equipment Overview (Cont'd)

B. Digital programming of setpoints through the universal keypad including:

1. Leaving chilled water temperature
2. Percent current limit
3. Pulls-down demand limiting
4. Six-week schedule for starting and stopping the chiller, pumps and tower
5. Remote reset temperature range

C. Status messages indicating:

1. System ready to start
2. System running
3. System coastdown
4. System safety shutdown – manual restart
5. System cycling shutdown – auto restart
6. System pre-lube
7. Start inhibit

D. The text displayed within the system status and system details field is displayed as a color-coded message to indicate severity: red for safety fault, orange for cycling faults, yellow for warnings, and green for normal messages.

E. Safety shutdowns enunciated through the display and the status bar, and consist of system status, system details, day, time, cause of shutdown, and type of restart required. Safety shutdowns with a fixed-speed drive include:

1. Evaporator – low pressure
2. Evaporator – transducer or leaving liquid probe
3. Evaporator – transducer or temperature sensor
4. Condenser – high pressure contacts open
5. Condenser – high pressure
6. Condenser – pressure transducer out-of-range
7. Auxiliary safety – contacts closed
8. Discharge – high temperature
9. Discharge – low temperature
10. Oil – high temperature
11. Oil – low differential pressure
12. Oil – high differential pressure
13. Oil – sump pressure transducer out-of-range

Equipment Overview (Cont'd)

14. Oil – differential pressure calibration
15. Oil – variable speed pump – pressure setpoint not achieved
16. Control panel – power failure
17. Motor or starter – current imbalance
18. Thrust bearing – proximity probe clearance (K compressors only)
19. Thrust bearing – proximity probe out-of-range (K compressors only)
20. Thrust bearing – position switch (P, Q & H9 compressors)
21. Watchdog – software reboot

F. Safety shutdowns with a VSD include:

1. VSD shutdown – requesting fault data
2. VSD – stop contacts open
3. VSD – 105% motor current overload
4. VSD – high phase A, B, C inverter heat-sink temp.
5. VSD – high converter heat-sink temperature (Filter Option Only)
6. Harmonic filter – high heat-sink temperature
7. Harmonic filter – high total demand distortion

G. Cycling shutdowns enunciated through the display and the status bar, and consists of system status, system details, day, time, cause of shutdown, and type of restart required.

H. Cycling shutdowns with a fixed speed drive include:

1. Multi unit cycling – contacts open
2. System cycling – contacts open
3. Oil – low temperature differential
4. Oil – low temperature
5. Control panel – power failure
6. Leaving chilled liquid – low temperature
7. Leaving chilled liquid – flow switch open
8. Motor controller – contacts open
9. Motor controller – loss of current
10. Power fault

Equipment Overview (Cont'd)

11. Control panel – schedule
 12. Starter – low supply line voltage (SSS option)
 13. Starter – high supply line voltage (SSS option)
 14. Proximity probe – low supply voltage (K Compressor)
 15. Oil – variable speed pump – drive contacts open
- I. Cycling shutdowns with a VSD include:
1. VSD shutdown – requesting fault data
 2. VSD – stop contacts open
 3. VSD – initialization failed
 4. VSD – high phase A, B, C instantaneous current
 5. VSD – phase A, B, C gate driver
 6. VSD – single phase input power
 7. VSD – high DC bus voltage
 8. VSD – precharge DC bus voltage imbalance
 9. VSD – high internal ambient temperature
 10. VSD – invalid current scale selection
 11. VSD – low phase A, B, C inverter heat-sink temp.
 12. VSD – low converter heat-sink temperature
 13. VSD – precharge – low DC bus voltage
 14. VSD – logic board processor
 15. VSD – run signal
 16. VSD – serial communications (Filter Option Only)
 17. Harmonic filter – logic board or communications
 18. Harmonic filter – high DC bus voltage
 19. Harmonic filter – high phase A, B, C current
 20. Harmonic filter – phase locked loop
 21. Harmonic filter – precharge – low DC bus voltage
 22. Harmonic filter – DC bus voltage imbalance
 23. Harmonic filter – 110% input current overload
 24. Harmonic filter – logic board power supply
 25. Harmonic filter – run signal

Equipment Overview (Cont'd)

- 26. Harmonic filter – DC current transformer 1
- 27. Harmonic filter – DC current transformer 2
- J. Security access to prevent unauthorized change of setpoints, to allow local or remote control of the chiller, and to allow manual operation of the pre-rotation vanes and oil pump. Access is through ID and password recognition, which is defined by three different levels of user competence: view, operator, and service.
- K. Trending data with the ability to customize points of once every second to once every hour. The panel will trend up to 6 different parameters from a list of over 140, without the need of an external monitoring system.
- L. The operating program stored in non-volatile memory (EPROM) to eliminate reprogramming the chiller due to AC power failure or battery discharge. Programmed setpoints are retained in lithium battery-backed RTC memory for a minimum of 5 years with power removed from the system.
- M. A fused connection through a transformer in the compressor motor starter to provide individual over-current protected power for all controls.
- N. A numbered terminal strip for all required field interlock wiring.
- O. An RS-232 port to output all system operating data, shutdown/cycling message, and a record of the last 10 cycling or safety shutdowns to a field-supplied printer. Data logs to a printer at a set programmable interval. This data can be preprogrammed to print from 1 minute to 1 day.
- P. The capability to interface with a building automation system via hard-wired connections to each feature to provide:
 - 28. Remote chiller start and stop
 - 29. Remote leaving chiller liquid temperature adjust
 - 30. Remote current limit setpoint adjust
 - 31. Remote ready to start contacts
 - 32. Safety shutdown contacts
 - 33. Cycling shutdown contacts
 - 34. Run contacts

REFRIGERANT FLOW CONTROL

Refrigerant flow to the evaporator is controlled by the YORK variable orifice control system. Liquid refrigerant level is continuously monitored to provide optimum subcooler, condenser and evaporator performance. The variable orifice electronically adjusts to all Real-World operating conditions, providing the most efficient and reliable operation of refrigerant flow control.

Equipment Overview (Cont'd)

CODES AND STANDARDS

- ASME Boiler and Pressure Vessel Code – Section VIII Division 1.
- UL 1995 – Heating and Cooling Equipment
- ASHRAE 15 – Safety Code for Mechanical Refrigeration
- ASHRAE Guideline 3 – Reducing Emission of Halogenated Refrigerants in Refrigeration and Air-Conditioning Equipment and Systems
- N.E.C. – National Electrical Code
- OSHA – Occupational Safety and Health Act

ISOLATION MOUNTING

The unit is provided with four vibration isolation mounts of nominal 1" operating height. The pads have a neoprene pad to contact the foundation, bonded to a steel plate. The vibration isolation pads assemblies mount under steel plates affixed to the chiller tube sheets.

IBC/OSHPD SEISMIC CERTIFICATION

YORK YK chillers meet the IBC seismic requirements. YORK YK chillers also meet the California Office of Statewide Health Planning and Development (OSHPD) Special Seismic Preapproval (OSP). To earn the OSP, several models within a product line are required to successfully demonstrate functional operation after a shaker-table test. All Johnson Controls equipment is engineered and manufactured for the highest level of safety. Contact a Johnson Controls sales office to obtain a specific selection for a seismic compliance application.

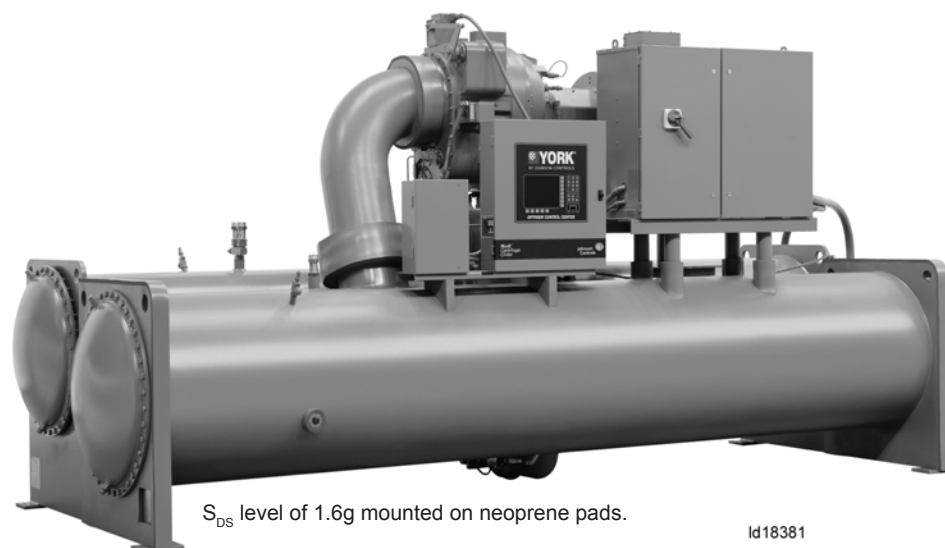

FIGURE 1 - SPECIAL SEISMIC CERTIFICATION PREAPPROVAL

Equipment Overview (Cont'd)

REFRIGERANT CONTAINMENT

The standard unit has been designed as a complete and compact factory-packaged chiller. As such, it has minimum joints from which refrigerant can leak. The entire assembly has been thoroughly leak tested at the factory prior to shipment. The YORK YK chiller includes service valves conveniently located to facilitate transfer of refrigerant to a remote refrigerant storage/recycling system. Optional condenser isolation valves allow storage of the charge in the condenser.

PAINT

Exterior surfaces are protected with one coat of Caribbean blue, durable alkyd modified, vinyl enamel machinery paint.

SHIPMENT

A protective covering is furnished on the motor starter, Control Center VSD and unit mounted controls. Water nozzles are capped with fitted plastic caps. The entire unit is protected with a industrial-grade, reinforced shrink-wrapped covering.

THIS PAGE INTENTIONALLY LEFT BLANK.

OptiView Control Center

YK OPTIVIEW CONTROL CENTER

The YORK OptiView™ Control Center, furnished as standard on each chiller, provides the ultimate in efficiency, monitoring, data recording, chiller protection and operating ease. The Control Center is a factory-mounted, wired and tested state-of-the-art microprocessor based control system for HFC-134a centrifugal chillers. The panel is configured with a 10.4-in. (264 mm) diagonal color Liquid Crystal Display (LCD) surrounded by “soft” keys, which are redefined with one keystroke based on the screen displayed at that time. This revolutionary development makes chiller operation quicker and easier than ever before. Instead of requiring keystroke after keystroke to hunt for information on a small monochrome LCD screen, a single button reveals a wide array of information on a large, full-color illustration of the appropriate component, which makes information easier to interpret. This is all mounted in the middle of a keypad interface and installed in a locked enclosure.



The LCD display allows graphic animated display of the chiller, chiller sub-systems and system parameters; this allows the presentation of several operating parameters at once. In addition, the operator may view a graphical representation of the current as well as historical operation of the chiller. A Status Bar is displayed at all times on all screens. It contains the System - Status Line and Details Line, the Control Source, Access Level, and Time and Date.

During pre-lube and coast-down, the system status will include a countdown timer indicating the time remaining. The control panel is compatible with the YORK Variable Speed Drive (VSD) (Optional), YORK Solid-State Starter (optional), or any Electro-Mechanical (E-M) starter that complies with the YORK R-1132 standard. The locations of various chiller parameters are clearly marked and instructions for specific operations are provided for on many of the screens. The panel verbiage is available in eight languages as standard and can be changed on the fly without having to turn off the chiller. Data can be displayed in either English or Metric units plus keypad entry of setpoints to 0.1 increments.

Security access is provided to prevent unauthorized changes of setpoints. This is accomplished with three different levels of access and passwords for each level. There are cer-

OptiView Panel (Cont'd)

tain screens, displayed values, programmable setpoints and manual controls not shown that are for servicing the chiller. They are only displayed when logged in at service access level. Included in this is the Advanced Diagnostics and troubleshooting information for the chiller and the panel.

The panel is fused through a 1-1/2 or 2 KVA transformer in the compressor motor starter to provide individual over-current protected power for all controls. Numbered terminal strips for wiring components such as Remote Start/Stop, Flow Switches, Chilled Water Pump and Local or Remote Cycling devices are provided. The panel also provides dry contacts that indicate the chiller status. These contacts include a Remote Mode Ready-to-Start, a Cycling Shutdown, a Safety Shutdown and a chiller Run contact.

Setpoints can be changed from a remote location via 0-10VDC, 4-20mA, contact closures or through serial communications. The adjustable remote reset range [up to 20°F (11.1°C)] provides flexible, efficient use of remote signal depending on reset needs. Serial data interface to the Building Automation System (BAS) is through the optional factory-mounted E-Link, installed inside the Control Center.

The E-Link requests the data from the microboard and makes it available for the Johnson Controls Metasys® network. The operating program is stored in an EPROM to eliminate chiller failure due to AC power failure/battery discharge. Programmed setpoints are retained in lithium battery-backed RTC memory for 10 years minimum.

Smart Freeze Point Protection will run the chiller at 36°F (2.2°C) leaving chilled water temperature and prevent nuisance trips on Low Water Temperature. The sophisticated program and sensor will monitor the chiller water temperature to prevent freeze up.

Every programmable point has a pop-up screen with the allowable ranges, so that the chiller cannot be programmed to operate outside of its design limits. When the power is applied to the chiller, the HOME screen is displayed. This screen displays a visual representation of the chiller and a collection of data detailing important operations and parameters. When the chiller is running the flow of chilled liquid is animated by the alternating shades of color moving in and out of the pipe nozzles. The primary values that need to be monitored and controlled are shown on this screen. They are as follows:

Display Only

- Chilled Liquid Temperature – Leaving
- Chilled Liquid Temperature – Return
- Condenser Liquid Temperature – Return
- Condenser Liquid Temperature – Leaving
- Motor Run (LED)
- % Full Load Amps
- Operating Hours
- Input Power (kW) (VSD Only)
- Heating Condenser Liquid Temperature – Leaving (Heat Recovery only)
- Heating Condenser Liquid Temperature – Return (Heat Recovery only)

OptiView Panel (Cont'd)

With the “soft” keys the operator is only one touch away from the eight main screens that allows access to the major information and components of the chiller. The eight screens are the **SYSTEM, EVAPORATOR, CONDENSER, COMPRESSOR, OIL SUMP, MOTOR, SETPOINTS** and the **HISTORY**. Also on the Home screen is the ability to Log IN, Log Out and Print. Log In and Log Out is the means by which different security levels are accessed.

The **SYSTEM** screen gives a general overview of common chiller parameters for both shells. This is an end view of the chiller with a 3D cutaway of both the shells. From this screen you can view the following.

Display Only

- Discharge Temperature
- Chilled Liquid Temperature – Leaving
- Chilled Liquid Temperature – Return
- Chilled Liquid Temperature – Setpoint
- Evaporator Pressure
- Evaporator Saturation Temperature
- Condenser Liquid Temperature – Leaving
- Condenser Liquid Temperature – Return
- Condenser Pressure
- Condenser Saturation Temperature
- Oil Sump Temperature
- Oil Pressure
- % Full Load Amps
- Current Limit
- Heating Condenser Liquid Temperature – Leaving – (Heat Recovery only)
- Heating Condenser Liquid Temperature – Entering – (Heat Recovery only)
- Heating Condenser Leaving Liquid Temperature – Setpoint – (Heat Recovery only)

The **EVAPORATOR** screen displays a cutaway view of the chiller evaporator. All setpoints relating to the evaporator side of the chiller are maintained on this screen. Animation of the evaporation process indicates whether the chiller is presently in **RUN** condition (bubbling) and liquid flow in the pipes is indicated by alternating shades of color moving in and out of the pipes. Adjustable limits on the low water temperature setpoints allow the chiller to cycle on and off for greater efficiency and less chiller cycling. The chiller cycles off when the leaving chilled water temperature is below the setpoint and is adjustable from 1°F (0.55°C) below to a minimum of 36°F (2.2°C). Restart is adjustable from the setpoint up to a max of 80°F (44.4°C). The panel will check for flow to avoid freeze up of the tubes. If flow is interrupted shutdown will occur after a minimum of two seconds. From this screen you can perform the following.

OptiView Panel (Cont'd)

Display Only

- Chilled Liquid Flow Switch (Open/Closed)
- Chilled Liquid Pump (Run/Stop)
- Evaporator Pressure
- Evaporator Saturation Temperature
- Return Chilled Liquid Temperature
- Leaving Chilled Liquid Temperature
- Evaporator Refrigerant Temperature
- Small Temperature Difference
- Leaving Chilled Liquid Temperature Setpoints – Control Setpoint
- Leaving Chilled Liquid Temperature Setpoints –
- Shutdown
- Leaving Chilled Liquid Temperature Setpoints –
- Restart

Programmable

- Local Leaving Chilled Liquid Temperature – Range
- Local Leaving Chilled Liquid Temperature – Setpoint
- Leaving Chilled Liquid Temperature Cycling Offset – Shutdown
- Leaving Chilled Liquid Temperature Cycling Offset – Restart

The **CONDENSER** screen displays a cutaway view of the chiller condenser. The liquid flow is animated to indicate flow through the condenser. All setpoints relating to the condenser side of the chiller are maintained on this screen. With the proper access level, this screen also serves as a gateway to controlling the Refrigerant Level. From this screen you can view the following:

Display Only

- Leaving Condenser Liquid Temperature
- Return Condenser Liquid Temperature
- Condenser Pressure
- Condenser Saturation Temperature
- Small Temperature Difference
- Drop Leg Refrigerant Temperature
- Sub-Cooling Temperature
- High Pressure Switch (Open/Closed)

OptiView Panel (Cont'd)

- Condenser Liquid Flow Switch
- Condenser Liquid Pump (Run/Stop)
- Refrigerant Level Position
- Refrigerant Level Setpoint
- Ramp Up Time Remaining
- Return Heating Condenser Liquid Temperature (Heat Recovery only)
- Leaving Heating Condenser Liquid Temperature (Heat Recovery only)

HEAT RECOVERY

The **HEAT RECOVERY** screen displays a cutaway view of the chiller condenser. The liquid flow is animated to indicate flow when there is flow in either the lower tower bundle or upper heating bundle. All setpoints relating to the upper heating bundle are maintained on this screen. From this screen you can view the following:

Display Only

- Return heating condenser liquid temperature
- Leaving heating condenser liquid temperature
- Return condenser liquid temperature
- Leaving condenser liquid temperature
- Hot water active setpoint

The **COMPRESSOR** screen displays a cutaway view of the compressor; this reveals the impeller and shows all the conditions associated with the compressor. When the compressor impeller is spinning this indicates that the chiller is presently in **RUN** condition. With the proper access level, the pre-rotation vanes may be manually controlled. This screen also serves as a gateway to sub-screens for calibrating the pre-rotation vanes, the proximity probe, configuring the Hot Gas Bypass, or providing advanced control of the compressor motor Variable Speed Drive. From this screen you can view the following:

Display Only

- Oil Pressure
- Oil Sump Temperature
- Discharge Temperature
- High Speed Thrust Bearing Oil Drain Temperature
- High Speed Thrust Bearing Proximity Differential
- High Speed Thrust Solenoid (LED)
- Vane Motor Switch (LED)
- Oil Return Solenoid (LED)

OptiView Panel (Cont'd)

- Vent Line Solenoid (LED)
- Liquid Line Solenoid (LED)
- Oil Pump Drive Command Frequency (VS OIL Pump Only)

The **OIL SUMP** screen displays a close-up view of the chiller oil sump and provides all the necessary setpoints for maintaining the Variable Speed Oil Pump (VSOP). This screen also allows manual control of the frequency command sent to the VSOP. From this screen you can perform the following:

Display Only

- Oil Sump Temperature
- Sump Oil Pressure (LOP)
- Pump Oil Pressure (HOP)
- Oil Pressure
- Oil Pump Run Output (LED)
- Oil Return Solenoid (LED)
- Oil Heater (LED – VSOP Only)
- Target/Setpoint Oil Pressure (VSOP Only)
- Pulldown Time Remaining (VSOP Only)
- Variable Speed Oil Pump Control Mode (VSOP Only)
- Oil pump Drive Command Frequency (VSOP Only)
- Manual Oil Pump Operation Time Left

Programmable

- Manual Pump

The **MOTOR** “soft” key on the Home screen when pressed shows a picture of a YORK Electro-Mechanical Starter, Solid-State Starter, or a Variable Speed Drive Screen depending on chiller configuration. Programmable pulldown demand to automatically limit motor loading for minimizing building demand charges is provided. Pulldown time period control over four hours, and verification of time remaining in pulldown cycle from display readout. Separate digital setpoint for current limiting between 30 and 100%.

The **ELECTRO-MECHANICAL STARTER** – (E-M) screen displays a picture of the starter and the following values, the ones below are common among all three offerings and the values will be displayed on all types of starter screens. From this screen you can perform the following:

Display Only

- Motor Run (LED)
- Motor Current %Full Load Amps
- Current Limit Setpoints
- Pulldown Demand Time Left

OptiView Panel (Cont'd)

Programmable

- Local Motor Current Limit
- Pulldown Demand Limit
- Pulldown Demand Time

The **SOLID-STATE STARTER** – (SSS) screen displays a picture of the starter and following values that are displayed in addition to the common ones listed above.

Display Only

- Scale/Model
- Voltage – Phase A, B, C
- Current – Phase A, B, C
- Input Power
- Kilowatt hours

The **VARIABLE SPEED DRIVE** - (VSD) screen displays a picture of the VSD and the following values that are in addition to the common ones listed above. From this screen you can view the following:

Display Only

- Output Voltage
- Output Frequency
- Current – Phase A, B, C
- Input Power
- kW Hours
- Pre-Rotation Vane Position
- Harmonic Filter Data (filter option only)
- Supply KVA
- Total Power-factor
- Voltage Total Harmonic Distortion – L1, L2, L3
- Supply Current Total Demand Distortion – L1, L2, L3

There are two additional screens (sub-screens) that have further VSD information. From these screens you can view the following:

Variable Speed Drive Details:

Display Only

- Water Pump Output (LED)
- Precharge Relay Output (LED)

OptiView Panel (Cont'd)

- Trigger SCR Output (LED)
- DC Bus Voltage
- DC Inverter Link Current
- Internal Ambient Temperature
- Converter Heat-sink Temperature
- Heat-sink Temperature – Phase A, B, C
- Motor HP
- 100% Full Load Amps

Harmonic Filter Details (Filter option only)

Display Only

- Operating Mode (Run/Stop)
- DC Bus Voltage
- Supply Contactor (LED)
- Precharge Contactor (LED)
- Phase Rotation
- Total Supply KVA
- Base Plate Heat-sink Temperature
- Voltage Peak (N-L1, N-L2, N-L3)
- RMS Voltage (L1, L2, L3)
- Voltage Total Harmonic Distortion (L1, L2, L3)
- RMS Filter Current (L1, L2, L3)
- Supply Current Total Demand Distortion
- RMS Supply Current L1, L2, L3

The **SETPOINTS** screen provides a convenient location for programming the most common setpoints involved in the chiller control. The Setpoints are shown on other individual screens but to cut down on needless searching they are on this one screen. This screen also serves as a gateway to a sub-screen for defining the setup of general system parameters. From this screen you can perform the following:

Display Only

- Leaving Chilled Liquid Temperature – Setpoint
- Leaving Chilled Liquid Temperature Cycling –
- Shutdown

OptiView Panel (Cont'd)

- Leaving Chilled Liquid Temperature Cycling –
- Restart

Programmable

- Local Leaving Chilled Liquid Temperature – Range
- Local Leaving Chilled Liquid Temperature – Setpoint
- Leaving Chilled Liquid Temperature Cycling Offset – Shutdown
- Leaving Chilled Liquid Temperature Cycling Offset – Restart
- Motor Current Limit
- Pulldown Demand Limit
- Pulldown Demand Time
- Print

The **SETUP** is the top level of the general configuration parameters. It allows programming of the time and date, along with specifications as to how the time will be displayed. In addition, the chiller configuration as determined by the microboard program jumpers and program switches is displayed. From this screen you can perform the following:

Display Only

- Chilled Liquid Pump Operation: (displays standard or enhanced)
- Motor Type: (displays fixed speed or variable speed)
- Refrigerant Selection: (displays HFC-134a)
- Anti-Recycle: (displays Disabled or Enabled)
- Power Failure Restart: (displays Manual or Automatic)
- Liquid Type: (Water or Brine)
- Coastdown: (displays Standard or Enhanced)
- Pre-Run: (Displays Standard or Extended)
- Oil Pump Package: (displays Fixed Speed or Variable Speed)
- Power Line Frequency (VSD only): (displays 60 Hz or 50 Hz)

Programmable

- Set Date
- Set Time
- Clock (Enabled/Disabled)
- 12/24 Hr

The following 6 sub-screens can be accessed from the setup screen:

OptiView Panel (Cont'd)

The **SCHEDULE** screen contains more programmable values than a normal display screen. Each programmable value is not linked to a specific button; instead the select key is used to enable the cursor arrows and check key to program the Start/Stop times for any day of the week up to 6 weeks in advance. The user has the ability to define a standard set of Start/Stop times that are utilized every week or specify exceptions to create a special week.

Programmable

- Exception Start/Stop Times
- Schedule (Enable/ Disabled)
- Repeat Sunday Schedule
- Standard Week Start/Stop Times
- Reset All Exception Days
- Select
- Print

The **USER** screen allows definition of the language for the chiller to display and defines the unit of measure.

Programmable

- System Language
- English/Metric Units

The **COMMS** screen allows definition of the necessary communications parameters.

Programmable

- Chiller ID
- Com 2 Baud Rate
- Com 2 Data Bit(s)
- Com 2 Parity Bit(s)
- Com 2 Stop Bit(s)
- Printer Baud Rate
- Printer Data Bit(s)
- Printer Parity Bit(s)
- Printer Stop Bit(s)

The **PRINTER** screen allows Definition of the necessary communications Parameters for the printer.

Display Only

- Time Remaining Until Next Print

OptiView Panel (Cont'd)

Programmable

- Log Start Time
- Output Interval
- Automatic Printer Logging (Enabled/Disabled)
- Print Type
- ACC Auto Map Print (Enable/Disabled)
- ACC Map Report
- Print Report
- Print All Histories

The **SALES ORDER** screen allows definition of the order parameters.

Note: This information is loaded at the factory or by the installation/service technician.

Display Only

- Model Number
- Panel Serial Number
- Chiller Serial Number
- Johnson Controls Order Number
- System Information
- Condenser and Evaporator Design Load Information
- Nameplate Information

The **OPERATIONS** screen allows definition of parameters related to the operation of the chiller. What is defined is whether the control of the chiller will be Local, Digital Remote, Analog Remote, Modem Remote or Metasys™ Remote.

Programmable

- Control Source

The **HISTORY** screen allows the user to browse through the last ten faults; either safety or cycling shutdowns with the conditions while the chiller is running or stopped. The faults are color coded for ease in determining the severity at a glance, recording the date, time and description. (See Display Messages for Color Code meanings.)

Display Only

- Last Normal Shutdown
- Last Fault While Running
- Last Ten Faults

Programmable

- Print History

OptiView Panel (Cont'd)

- Print All Histories

By pressing the **VIEW DETAILS** key you will move to the **HISTORY DETAILS** screen. From these screens you are able to see an on-screen printout of all the system parameters at the time of the selected shutdown.

Display Only

- History Printout

Programmable

- Page Up
- Page Down
- Print History

Also under the History screen is the **TRENDING** screen, accessible by the key marked the same. On this screen up to six operator-selected parameters, selected from a list of over 140, can be plotted in an X/Y graph format. The graph can be customized to record points once every second up to once every hour. There are two types of charts that can be created: a single or continuous screen. The single screen collects data for one screen width (450 data points across the x-axis) then stops. The continuous screen keeps collecting the data but the oldest data drops off the graph from left to right at the next data collection interval. For ease of identification, each plotted parameter, title and associated Y-axis labeling is color coordinated.

Display Only

- This screen allows the user to view the graphical trending of the selected parameters and is a gateway to the graph setup screens.

Programmable

- Start
- Stop
- Y-axis
- X-axis

The **TREND SETUP** screen is used to configure the trending screen. The parameters to be trended are selected from the Trend Common Slots Screen accessed from the Slot #s button or the Master Slot Numbers List found in the operating manual. The interval at which all the parameters are sampled is selected under the Collection Interval button. The data point min. and MAXIMUM values may be adjusted closer within the range to increase viewing resolution.

Programmable

- Chart Type (select Continuous or One Screen)
- Collection Interval
- Select
- Data Point Slot # (1-6)

OptiView Panel (Cont'd)

- Data Point Min (1-6)
- Data Point Max (1-6)

The **TREND COMMON SLOTS** screen displays the Master Slot Numbers List of the monitored parameters.

Display Only

- Slot Numbers

Programmable

- Page Up
- Page Down

DISPLAY MESSAGES

The Control Center continually monitors the operating system displaying and recording the cause of any shutdowns (Safety, Cycling or Normal). The condition of the chiller is displayed at the System Status line that contains a message describing the operating state of the chiller; whether it is stopped, running, starting or shutting down. A System Details line displays Warning, Cycling, Safety, Start Inhibit and other messages that provide further details of Status Bar messages. Messages are color-coded: Green – Normal Operations, Yellow - Warnings, Orange – Cycling Shutdowns, and Red – Safety Shutdowns to aid in identifying problems quickly.

Status Messages include:

- System Ready to Start
- Cycling Shutdown – Auto Restart
- Safety Shutdown – Manual Restart
- System Pre-lube (with countdown timers)
- System Run (with countdown timers)
- System Coastdown (with countdown timers)
- Start Inhibit
- Vanes Closing Before Shutdown

Run Messages include:

- Leaving Chilled Liquid Control
- Current Pulldown Limit

Start Inhibit Messages include:

- Anti-Recycle XX Min/Sec
- Vane Motor Switch Open
- Motor Current >15% FLA

OptiView Panel (Cont'd)

Warning Messages include:

- Real Time Clock Failure
- Condenser or Evaporator Transducer Error
- Refrigerant level Out-of-Range
- Standby Lube – Low Oil Pressure
- Setpoint Override
- Condenser – High Pressure Limit
- Evaporator – Low Pressure Limit
- Motor – High Current Limit (E-M and SSS options only)
- Vane Uncalibrated – Fixed Speed (VSD option only)
- **(Filter option only)**
- Harmonic Filter – Operation Inhibited
- Harmonic Filter – Data Loss
- Harmonic Filter – Input Frequency Range

Routine Shutdown Messages include:

- Remote Stop
- Local Stop
- Place Compressor Switch in Run Position

Cycling Shutdown Messages include:

- Multi Unit Cycling – Contacts Open
- System Cycling – Contacts Open
- Oil – Low Temperature Differential
- Oil – Low Temperature
- Control Panel – Power Failure
- Leaving Chilled Liquid – Low Temperature
- Leaving Chilled Liquid – Flow Switch Open
- Condenser – Flow Switch Open
- Motor Controller – Contacts Open
- Motor Controller – Loss of Current
- Power Fault
- Control Panel – Schedule

OptiView Panel (Cont'd)

- Starter – Low Supply Line Voltage (SSS option only)
- Starter – High Supply Line Voltage (SSS option only)
- Proximity Probe – Low Supply Voltage
- Oil – Variable Speed Pump – Drive Contacts Open

Compressor Motor Variable Speed Drive: Cycling Shutdown Messages include (VSD only):

- VSD Shutdown – Requesting Fault Data
- VSD – Stop Contacts Open
- VSD – Initialization Failed
- VSD – High Phase A, B, C Instantaneous Current
- VSD – Phase A, B, C Gate Driver
- VSD – Single-Phase Input Power
- VSD – High DC Bus Voltage
- VSD – Logic Board Power Supply
- VSD – Low DC Bus Voltage
- VSD – DC Bus Voltage Imbalance
- VSD – Precharge – DC Bus Voltage Imbalance
- VSD – High Internal Ambient Temperature
- VSD – Invalid Current Scale Selection
- VSD – Low Phase A, B, C Inverter Heat-sink Temperature
- VSD – Low Converter Heat-sink Temperature
- VSD – Precharge – Low DC Bus Voltage
- VSD – Logic Board Processor
- VSD – Run Signal
- VSD – Serial Communications

OptiView Panel (Cont'd)

(Filter option only)

- Harmonic Filter – Logic Board or Communications
- Harmonic Filter – High DC Bus Voltage
- Harmonic Filter – High Phase A, B, C Current
- Harmonic Filter – Phase Locked Loop
- Harmonic Filter – Precharge – Low DC Bus Voltage
- Harmonic Filter – Low DC Bus Voltage
- Harmonic Filter – DC Bus Voltage Imbalance
- Harmonic Filter – 110% Input Current Overload
- Harmonic Filter – Logic Board Power Supply
- Harmonic Filter – Run Signal
- Harmonic Filter – DC Current Transformer 1
- Harmonic Filter – DC Current Transformer 2

Safety Shutdown Messages include:

- Evaporator – Low Pressure
- Evaporator – Transducer or Leaving Liquid Probe
- Evaporator – Transducer or Temperature Sensor
- Condenser – High Pressure Contacts Open
- Condenser – High Pressure
- Condenser – Pressure Transducer Out-of-Range
- Auxiliary Safety – Contacts Closed
- Discharge – High Temperature
- Discharge – Low Temperature

OptiView Panel (Cont'd)

- Oil – High Temperature
- Oil – Low Differential Pressure
- Oil – High Differential Pressure
- Oil – Pump Pressure Transducer Out-of-Range
- Transducer Out-of-Range
- Oil – Differential Pressure Calibration
- Oil – Variable Speed Pump – Setpoint Not Achieved
- Control Panel – Power Failure
- Motor Or Starter – Current Imbalance (SSS option only)
- Thrust Bearing – Proximity Probe Clearance (K Compressor)
- Thrust Bearing – Proximity Probe Out Of Range (K Compressor)
- Thrust Bearing – Position Switch (P, Q, & H9 Compressors)
- Watchdog – Software Reboot

Compressor Motor VSD: Safety Shutdown Messages include: (VSD only)

- VSD Shutdown – Requesting Fault Data
- VSD – Stop contacts Open
- VSD – 105% Motor Current Overload
- VSD – High Phase A, B, C Inverter Heat-sink Temperature
- VSD – High Converter Heat-sink Temperature
- VSD – Precharge Lockout
- **(Filter option only)**
- Harmonic Filter – High Heat-sink Temperature
- Harmonic Filter – High Total Demand Distortion

THIS PAGE INTENTIONALLY LEFT BLANK.

Accessories and Modifications

STARTERS

Optispeed™ Drive Starter

When a YORK YK chiller is equipped with a variable speed drive, it incorporates advanced Adaptive Capacity Control logic, which continually optimizes chiller operation. It closely examines critical operating parameters, and then determines the most efficient way to operate. In addition, it allows optimized savings when using intelligent control strategies, such as chilled-water reset. Adaptive Capacity Control logic also accommodates the characteristics of the refrigerant used in the chiller — today and tomorrow.

The variable speed drive was specifically developed for commercial air-conditioning applications. No one matches Johnson Controls experience in the application of variable speed drive technology to chillers. Since pioneering the concept in 1978, Johnson Controls has installed more variable speed drive chillers than all other chiller manufacturers combined.

Variable speed drives will save in both single-chiller installations and multiple-chiller installations. In multiple-chiller installations, cycling chillers off as the building load falls will result in higher loads on the remaining chillers. This would seem to reduce the opportunity for drives to save energy. However, even though chiller loads remain high, entering condenser-water temperature has most likely fallen. And, reductions in entering condenser water temperature offer a far greater potential to enhance chiller efficiency than load reductions do. Therefore, variable speed drive will deliver major energy savings in multiple-chiller plants, too.

The OptiSpeed Drive is available for low and medium voltage options for the compressor motor (See Table 1).

TABLE 1 - OPTISPEED DRIVE STARTER OPTION

LOW VOLTAGE STARTERS								
OPTISPEED VARIABLE SPEED DRIVE UNIT MOUNTED	60 HZ				50 HZ			
	380V	460V	575V	600V	380V	400V	415V	
	X	X	X	X	X	X	X	–
60 HZ MEDIUM VOLTAGE STARTERS								
OPTISPEED VARIABLE SPEED DRIVE FLOOR MOUNTED	2300V	3300V	4000V	4160V	6000V	6600V	12470V	13800V
	X	X	X	X	Y	Y	Y	Y
50 HZ MEDIUM VOLTAGE STARTERS								
OPTISPEED VARIABLE SPEED DRIVE FLOOR MOUNTED	2300V	3000V	3300V	6000V	6600V	10000V	11000V	
	–	–	X	Y	Y	Y	Y	–

Y=Available by Special Quotes (SQ)

Accessories and Modifications (Cont'd)

LOW VOLTAGE OPTISPEED DRIVE

The Low Voltage OptiSpeed variable speed drive is factory-packaged and mounted on the YORK YK chiller. It is designed to vary the compressor motor speed by controlling the frequency and voltage of the electrical power to the motor. The adaptive capacity control logic automatically adjusts motor speed and compressor pre-rotation vane position independently for maximum part load efficiency by analyzing information fed to it by sensors located throughout the chiller.

The variable speed drive is mounted in a NEMA-1 enclosure with all power and control wiring between the drive and chiller factory-installed. Electrical lugs for incoming power wiring are provided.

The variable speed drive provides automatic displacement power factor correction to 0.95 or better at all load conditions. Separate displacement power factor correction capacitors are not required. The displacement power factor is 0.98 or better when the optional harmonic filter is provided. Additionally, variable speed drives have the following advantages:

- Lowest chiller life cycle through part load energy savings.
- Application-specific designs enable efficient, precise load control and seamless integration with equipment control panel and BAS.
- Soft start with input current less than full load current.
- Smooth acceleration reduces stresses on motor and driveline.
- Reduces compressor sound levels at most operating conditions.
- Rugged and reliable with no moving parts.
- IEEE-519 1992 compliant if used with an optional harmonic filter.

Standard features include: a door interlocked lockable circuit breaker; UL/cUL listed ground fault protection; over-voltage and under-voltage protection; 3-phase sensing motor over-current protection; single-phase protection; insensitive to phase rotation; over-temperature protection; digital readout at the OptiView Control Center of:

- Output Frequency
- Output Voltage
- 3-phase output current
- Input Power (kW)
- Self diagnostic service parameters
- Kilowatt-Hours (kWh)

An optional harmonic filter limits electrical power supply distortion from the variable speed drive to help the building comply with the guidelines of IEEE Std. 519-1992. The filter is unit mounted within the same NEMA-1 enclosure and is UL listed. The following digital readout is standard with the optional filter:

- Input kVA
- Total power-factor
- 3-phase input voltage

Accessories and Modifications (Cont'd)

- 3-phase input current
- 3-phase input voltage total harmonic distortion (THD)
- 3-phase input current total demand distortion (TDD)
- Self-diagnostic service parameters

LOW VOLTAGE OPTISPEED DRIVE WITH QUICK START OPTION

The Quick Start feature is targeted towards data centers and process control applications where the goal is to re-establish process cooling as fast as possible after a power failure event. The Quick Start feature does this by reducing the time cycle for chiller restart and by loading the chiller as fast as possible. Once running, its goal is to rapidly achieve the leaving chilled water temperature setpoint. The main objective is to provide minimum downtime and the fastest restart/loading as possible. After the chiller is running and close to setpoint, it will return to standard YK control to minimize risk.

The Quick Start Feature can be used with a UPS (supplied by others) or without a UPS. In order to start the most quickly, the OptiView control panel and VSD control circuit (except the trigger board) must be on a UPS. If a slightly longer restart time can be tolerated, the UPS is not required.

Depending on the compressor and the horsepower of the drive, a 3 kVA or 4 kVA UPS (supplied by others) with sine wave output is required to power the OptiView and required portions of the VSD control circuit to 115V – 1 Ø – 60 Hz.

Please refer to Form 160.75-TD4; Quick Start Feature for YK Mod G Chillers for additional information.

Quick Start Feature Availability - This feature applies only to YK chillers with Low Voltage Variable Speed Drives.

MEDIUM VOLTAGE OPTISPEED DRIVE

A variable speed drive is factory-packaged and configured for easy remote mounting. It is designed to vary the compressor motor speed by controlling the frequency and voltage of the electrical power to the motor. The adaptive capacity control logic automatically adjusts motor speed and compressor pre-rotation vane position independently for maximum part load efficiency by analyzing information fed to it by sensors located throughout the chiller.

The variable speed drive is mounted in a NEMA-1 enclosure and comes with a certification label from a nationally recognized testing laboratory. The connection points between the drive and chiller are factory labeled. Electrical lugs for incoming power wiring are NOT provided.

The variable speed drive provides automatic displacement power factor correction to 0.98 or better at all load conditions. Separate displacement power factor correction capacitors are not required. Additional advantages of the variable speed drive are as follows:

- Lowest chiller life cycle through part load energy savings.
- Application-specific designs enable efficient, precise load control and seamless integration with equipment control panel and BAS.

Accessories and Modifications (Cont'd)

- Soft start with input current less than full load current.
- Smooth acceleration reduces stresses on motor and driveline.
- Reduces compressor sound levels at most operating conditions.
- Rugged and reliable with no moving parts.
- IEEE-519 1992 compliant with a harmonic filter.
- Multi-level PWM output closely simulates a true sine wave, allowing the use of standard motors and bearings.

Standard features include: a lockable door interlocked disconnect switch; UL listed ground fault protection; over-voltage and under-voltage protection; 3-phase sensing motor over-current protection; single-phase protection; insensitive to phase rotation; over-temperature protection; digital readout at the Control Center of:

- Output frequency
- 3-phase output voltage
- 3-phase output current
- Input power (kW)
- Self diagnostic service parameters
- Kilowatt-hours (kWH)
- Input KVA
- Total power-factor
- 3-phase input voltage
- 3-phase input current
- Self diagnostic service parameters

The 24 pulse design limits the electrical power supply distortion from the variable speed drive to comply with the guidelines of IEEE Std. 519-1992.

LOW VOLTAGE SOLID-STATE STARTER

The Low Voltage Solid-State Starter is compact and mounted on the unit. Power and control wiring between the starter and the chiller are factory-installed. Available for 200 - 600 volts (see Table 2), the starter enclosure is NEMA-1, with a hinged access door with lock and key. Electrical lugs for incoming power wiring are provided.

TABLE 2 - LOW VOLTAGE SOLID-STATE STARTER

LV SOLID-STATE STARTER (UNIT MOUNTED)	60HZ										50HZ				
	200V	208V	230V	240V	380V	440V	460V	480V	575V	600V	346V	380V	400V	415V	440V
	X	X	X	X	X	X	X	X	X	X	X	X	X	X	X

Accessories and Modifications (Cont'd)

Standard Features include digital readout at the Control Center of the following:

Display Only

- 3-phase input voltage
- 3-phase current
- Input Power (kW)
- Kilowatt-Hours (kWH)
- Starter Model
- Motor Run (LED)
- Motor Current % Full Load Amps
- Current Limit Setpoints
- Pulldown Demand Time Left

Programmable

- Local Motor Current Limit
- Pulldown Demand Limit
- Pulldown Demand Time

Other features include: low line voltage; 115V control transformer; three-leg, motor-current-sensing overloads; phase rotation and single-phase failure protection; high temperature safety protection; motor current imbalance and under-voltage safeties; open and shorted SCR protection; momentary power interruption protection. The Solid-State Starter is cooled by a closed-loop, fresh-water-circuit consisting of a water-to-water heat exchanger and a fractional horsepower circulating pump. All interconnecting water piping is factory-installed and rated for 150 psig (10.3 barg) working pressure. Optional electronic trip circuit UL listed circuit breaker with integral ground fault protection is available with short circuit withstand ratings of:

- 65KA for 460V 200V, 400V models
- 50KA for 33L 575V models
- 35KA for 14L 575V models
- 22KA for 7L 575V models

A non-fused disconnect switch is also available. Both options are lockable.

Additional advantages of Solid-State Starters are as follows:

- Smooth, controlled start profile.
- Unit mounted, factory wired and tested.
- Rugged and reliable with no moving parts.
- Adjustable acceleration times.

Accessories and Modifications (Cont'd)

- Reduces compressor sound levels at most operating conditions.
- Rugged and reliable with no moving parts.
- Application-specific designs enable seamless integration with equipment control panel and BAS.

MEDIUM VOLTAGE SOLID-STATE STARTER

The Medium Voltage Solid-State Starter is a reduced voltage in-line bypass starter that controls and maintains a constant current flow to the motor during startup. Power and control wiring between the starter and the chiller for the unit mounted version is factory-installed. Available for 2300 - 4160 volts (see Table 3), the starter enclosure is NEMA-1, with a hinged access door with lock and key. Electrical lugs for incoming power wiring are not provided.

TABLE 3 - MEDIUM VOLTAGE SOLID-STATE STARTER

MEDIUM VOLTAGE SOLID-STATE STARTER *	60 HZ				50 HZ
	2300V	3300V	4000V	4160V	3300V
UNIT MOUNTED	X**	X**	X**	X**	X**
FLOOR MOUNTED	X	X	X	X	X

* Unit Mounted version available for Compressor H9 or Larger

** For Higher Voltage contact Application Engineering Department for a Special Quote (SQ)

Standard Features include digital readout at the Control Center of the following:

Display Only

- 3-phase input voltage
- 3-phase current
- Input Power (kW)
- Killowatt-Hours (KWH)
- Starter Model
- Motor Run (LED)
- Motor Current % Full Load Amps
- Current Limit Setpoints
- Pulldown Demand Time Left

Programmable

- Local Motor Current Limit
- Pulldown Demand Limit
- Pulldown Demand Time

Other features include: low line voltage; 115V control transformer; three-leg motor current

Accessories and Modifications (Cont'd)

sensing overloads; phase rotation and single-phase failure protection; high temperature safety protection; motor current imbalance and under-voltage safeties; open and shorted SCR protection; momentary power interruption protection. The Solid-State Starter is air cooled generating about the same heat as an auto-transformer E-M starter. Ground fault protection and surge protection are also standard features. The 50,000 amp short circuit withstand rating is in accordance with UL Standard 508. See Table 6 for additional advantages of Solid-State Starters.

ELECTRO-MECHANICAL STARTER - (FIELD-INSTALLED)

Characteristics

For comparison purposes, here is a description of some of the general characteristics of electromechanical starters. Until the development of the Solid-State Starter, all centrifugal chillers required the use of starters using electro-mechanical contactors, which are limited to operating totally ON, or totally OFF. There was no alternative to this mechanical equipment with its inability to control applied voltage or power. This contrasts markedly with the YORK Medium Voltage Solid-State Starter which automatically maintains a predetermined current during starting, regardless of variations in line voltage or motor load, to give optimum acceleration without surges. Even with the addition of transformers, reactors, resistors and additional contactors, timers and relays, the mechanical controllers offer limited adjustment, no positive control during starting and impose an objectionable transition spike. Some also require modified motors. A field-installed, electro-mechanical compressor motor starter is available, selected for proper size and type for job requirements and in accordance with Johnson Controls Engineering Standard (R-1132) for Starters.

The most common failure mode of mechanical contactors is OFF. This occurs due to the coil open-circuiting or failure of a pole to make an electrical contact when it closes. However, failure in the ON mode is not completely uncommon and can be a more dramatic type of failure, particularly if this failure mode exists at the same time that equipment safety controls are demanding a shutdown.

When contacts are "made," the current builds up to its maximum value from zero, but when contacts are separated the current tends to flow through the gap thus formed and causes an arc. This arcing depends upon the voltage between the separating contacts. For medium voltage the use of vacuum contactors mitigates this problem somewhat by providing an environment to extinguish the arc. In the alternating current circuit, the separation of contacts may take place when the current is zero or maximum or at any value in between. An alternating current passes through zero and reverses its polarity twice during each cycle. If two or more contacts, one in each leg of a polyphase system, are separated simultaneously, the current values in each will vary. In a three-phase system, if one contact has zero current when opened, the other two contacts will have 86.6% of their maximum values, as an example. Additionally, when inductive circuits are broken, the voltage is increased at the contacts due to the counter (induced) EMF of the circuit. The instant the contacts separate, the voltage between them momentarily rises from zero to the maximum of the circuit, or higher if inductance is present in the circuit. In practice, every time the contacts close, they bounce. When they bounce, they arc. The arcing that occurs as the contacts make or break may result in rapid and excessive erosion of the contacts, causing prematurely short contact life.

Types

Accessories and Modifications (Cont'd)

YORK chillers are designed for use with the following types of electro-mechanical starters, here briefly described.

Across-the-Line (ACL) – These are the simplest and lowest-cost starters available. They apply full voltage to the three motor leads at the instant of starting. Since inrush is 100% of LRA and starting torque is 100%, this is the roughest type of starting on the motor and driveline. In physical size, the ACL is the smallest of electro-mechanical starters and there is no transition surge. In most areas, utilities will not permit the use of this type of starter for chiller-size motors because of their large current draw on startup.

Auto-Transformer (AT) – These starters are reduced-voltage starters. Transformers are used to step down the voltage to the motor during startup. The result is reduced inrush current and starting torque at the level of 42% or 64% depending upon whether 65% or 80% voltage taps are used. They provide closed transition (with three-lead motors) with reduced line disturbance.

Star-Delta Starters – During starting, the motor is connected in a Star or Wye configuration. This reduces the voltage to the motor stator by a factor of three. This 1/3 voltage results in 1/3 current into the motor at start and 1/3 torque to the shaft. Centrifugal compressor starting torque requirements are low enough to allow the motor to start at 1/3 of full load torque.

Star-Delta starting creates some stresses for the starter's switch-gear, building electrical system, power grid, and chiller mechanical driveline. Although these stresses are 1/3 of the stresses generated by an ACL starter, they cause wear on the system. As a result, Johnson Controls recommends using a Solid State Starter or Variable Speed Drive instead of a Star-Delta starter.

TABLE 4 - ELECTRO-MECHANICAL STARTER

STARTER OPTIONS	LOW VOLTAGE / FREQUENCY															
	60HZ											50HZ				
LV ACROSS THE LINE (DOL) (FLOOR MOUNTED)	200V	208V	230V	240V	380V	416V	440V	460V	480V	575V	600V	346V	380V	400V	415V	440V
	X	X	X	X	X	X	X	X	X	X	X	X	X	X	X	X
LV STAR-DELTA CLOSED (FLOOR MOUNTED)	60HZ											50HZ				
	200V	208V	230V	240V	380V	416V	440V	460V	480V	575V	600V	346V	380V	400V	415V	440V
	X	X	X	X	X	X	X	X	X	X	X	X	X	X	X	X

STARTER OPTIONS	MEDIUM VOLTAGE / FREQUENCY													
	60HZ							50HZ						
MV ACROSS THE LINE (DOL) (FLOOR MOUNTED)	2300	3300	4000	4160	6600	12470	13800	2300	3000	3300	6600	10000	11000	
	X	X	X	X	Y	Y	Y	X	X	X	Y	Y	Y	
MV AUTOTRANSFORMER 65% (FLOOR MOUNTED)	60HZ							50HZ						
	2300	3300	4000	4160	6600	12470	13800	2300	3000	3300	6600	10000	11000	
	X	X	X	X	Y	Y	Y	X	X*	X*	Y	Y	Y	
MV AUTOTRANSFORMER 80% (FLOOR MOUNTED)	60HZ							50HZ						
	2300	3300	4000	4160	6600	12470	13800	2300	3000	3300	6600	10000	11000	
	X	X	X	X	Y	Y	Y	X	X	X	Y	Y	Y	

GENERAL ACCESSORIES AND MODIFICATIONS

Accessories and Modifications (Cont'd)

Medium Voltage Motors

Medium voltage motors (4160V/60Hz to 13800V/60Hz and 3300V/50Hz to 11000V/50Hz) are available for YK units; Contact JCI Sales Office for special rating.

SPECIAL MOTORS ENCLOSURES

There are job applications, primarily in manufacturing, comfort cooling plants, and process applications, where more motor protection is required. Listed below are several alternatives. **NOTE:** Chiller certification to UL by a third party could be affected. Contact JCI sales office for a specific selection.

Weather-Protected Type I Motors (WP-I) – A Weather-Protected Type I motor is an open machine with its ventilating passages constructed to prevent the passage of a cylindrical rod $\frac{3}{4}$ " in diameter. This affords protection against intrusion of rodents and some types of debris. These are regularly used in the pulp industry and where grime is present.

Weather-Protected Type II Motors (WP-II) – A Weather-Protected Type II motor has, in addition to the enclosure defined for Weather-Protected Type I motor, ventilating passages at both intake and exhaust so arranged that high-velocity air and air-borne particles, blown into the motor, can be discharged without entering the internal ventilating passages leading directly to the electric parts of the machine itself. Space heaters are required with WP-II.

Totally Enclosed Fan-Cooled Motors (TEFC) – TEFC motors are used where the location is extremely dirty, dusty, or wet, both indoors and outdoors. A totally enclosed fan-cooled unit is enclosed to prevent the free exchange of air between the inside and outside of the case but not sufficiently enclosed as to be termed air-tight. It is air-cooled by means of a fully guarded fan blowing cooling air over the outside of the motor. The fan is externally mounted on the motor shaft.

Totally Enclosed Air-to-Air Cooled (TEAAC) – TEAAC motors are used when the environment is dirty or corrosive. A TEAAC motor is a totally enclosed motor, cooled by circulating the internal air through an air-to-air heat exchanger.

Totally Enclosed Water-to-Air Cooled (TEWAC) – TEWAC motors are used when the environment is dirty or corrosive, in hazardous areas, or where minimum noise levels are required. A TEWAC motor is a totally enclosed machine which is cooled by circulating internal air which, in turn, is cooled by circulating water. It is provided with an internal water-cooled heat exchanger for cooling the internal air and fans, integral with the rotor shaft for circulating the internal air.

BAS REMOTE CONTROL

A communication interface permitting complete exchange of chiller data with any BAS system is available with an optional E-Link gateway. The E-Link also allows the BAS system to issue commands to the chiller to control its operation. E-Link gateways come in four models, depending on the communication protocol and the mounting arrangement.

FACTORY INSULATION OF EVAPORATOR

Factory-applied thermal insulation of the flexible, closed-cell plastic type, $\frac{3}{4}$ " (19 mm)

Accessories and Modifications (Cont'd)

thick is attached with vapor-proof cement to the evaporator shell, flow chamber, tube sheets, suction connection, and (as necessary) to the auxiliary tubing. Not included is the insulation of compact waterboxes and nozzles. This insulation will normally prevent condensation in environments with relative humidities up to 75% and dry bulb temperatures ranging from 50° to 90°F (10° to 32.2°C). 1 1/2" (38 mm) thick insulation is also available for relative humidities up to 90% and dry bulb temperatures ranging from 50° to 90°F (10° to 32.2°C).

WATER FLANGES

Four 150 lb. ANSI raised-face flanges for condenser and evaporator water connections are factory-welded to water nozzles. Companion flanges, bolts, nuts and gaskets are not included.

SPRING ISOLATION MOUNTING

Spring isolation mounting is available instead of standard isolation mounting pads when desired. Four level-adjusting, spring-type vibration isolator assemblies with non-skid pads are provided for field-installation. Isolators are designed for one-inch (25 mm) deflection.

MARINE WATERBOXES

Marine waterboxes allow service access for cleaning of the heat exchanger tubes without the need to break the water piping. Bolted-on covers are arranged for convenient access. ANSI/AWWA C-606 nozzle connections are standard; flanges are optional. Marine waterboxes are available for condenser and/or evaporator.

HINGED WATERBOXES

Hinged waterboxes allow fast and safe service access for cleaning heat exchanger tubes. Hinged waterboxes on a non-nozzle end give access to the tubes without having to disconnect the water piping. Hinged waterboxes are available for condenser and/or evaporator for compact and marine waterboxes.

KNOCK-DOWN SHIPMENT

The chiller can be shipped knocked down into major subassemblies (evaporator, condenser, driveline, etc.) as required to rig into tight spaces. This is particularly convenient for existing buildings where equipment room access does not allow rigging a factory-packaged chiller.

REFRIGERANT ISOLATION VALVES

Optional factory-installed isolation valves in the compressor discharge line and refrigerant liquid line are available. This allows isolation and storage of the refrigerant charge in the chiller condenser during servicing, eliminating time-consuming transfers to remote storage vessels. Both valves are positive shut-off, assuring integrity of the storage system.

Accessories and Modifications (Cont'd)

REFRIGERANT STORAGE/RECYCLING SYSTEM

A refrigerant storage/recycling system is a self-contained package consisting of a refrigerant compressor with oil separator, storage receiver, water-cooled condenser, filter drier and necessary valves and hoses to remove, replace and distill refrigerant. All necessary controls and safety devices are a permanent part of the system. A storage receiver is typically not required if optional unit isolation valves are provided.

HIGH AMBIENT TEMPERATURE

Chiller modifications are available to allow for installation in high ambients of up to 122°F (50°C). Special drive motors are required above 104°F (40°C). H9 and K compressor evaporator design pressures must be increased for ambient temperatures above 112.8°F (45°C). The OptiView panel and low voltage VSD are suited for 122°F (50°C) ambient. Low and medium voltage Solid-State Starters must be derated and/or modified above 110°F (43.3°C). The free standing MVVSD option must be derated above its standard 104°F (40°C) limit.

OPTISOUND™ CONTROL

The YORK OptiSound™ Control is a patented combination of centrifugal-chiller hardware and software that reduces operational sound levels, expands the chiller operating range, and improves chiller performance. The OptiSound Control feature continuously monitors the characteristics of the compressor-discharge gas and optimizes the diffuser spacing to minimize gas-flow disruptions from the impeller. This innovative technology improves operating sound levels of the chiller an average of 7 dBA, and up to 13 dBA on the largest models. It can also reduce part-load sound levels below the full-load level. See Figure 2.

In addition, the OptiSound Control provides the benefit of an expanded operating range. It improves performance and reliability by minimizing diffuser-gas stall at off-design operation, particularly conditions of very low load combined with little or no condenser-water relief. The elimination of the gas-stall condition can also result in improved chiller efficiency at off-design conditions.

Johnson Controls recommends the OptiSound Control for chiller applications with elevated entering condenser-water temperatures (high-head) or applications requiring low-load operation with constant condenser temperature. At high-head conditions, improved chiller operation is visible at all load points.

Accessories and Modifications (Cont'd)

OptiSound Control Availability

Standard: Compressors P8, P9, H9, K1, K2, K3, K4, K7

Optional: Compressors Q3, Q4, Q5, Q6, Q7, P7

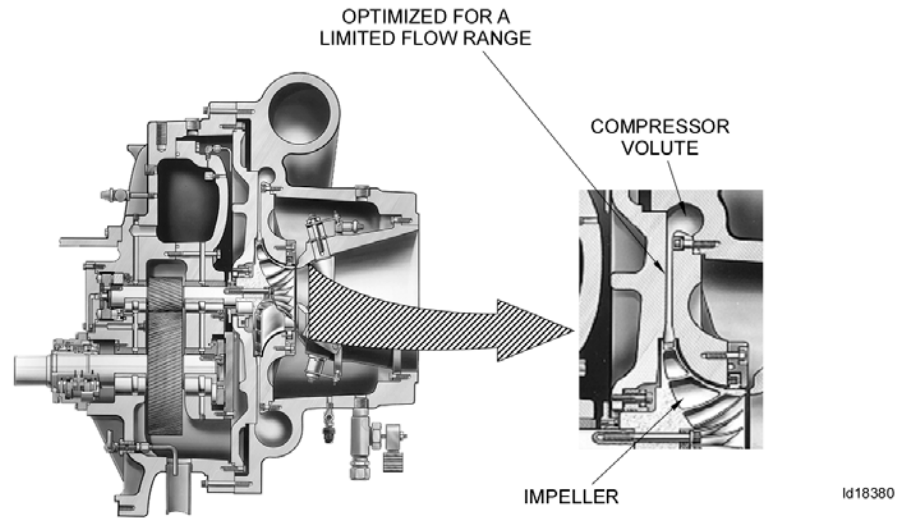

FIGURE 2 - TYPICAL OPTIMIZED CENTRIFUGAL COMPRESSOR

Application Data

The following discussion is a user's guide in the application and installation of YK chillers to ensure the reliable, trouble free life for which this equipment was designed. While this guide is directed towards normal, water chilling applications, the Johnson Controls sales representative can provide complete recommendations on other types of applications.

LOCATION

YK chillers are virtually vibration free and may generally be located at any level in a building where the construction will support the total system operating weight.

The unit site must be a floor, mounting pad or foundation which is level within 1/4" (6.4 mm) and capable of supporting the operating weight of the unit.

Sufficient clearance to permit normal service and maintenance work should be provided all around and above the unit. Additional space should be provided at one end of the unit to permit cleaning of evaporator and condenser tubes as required. A doorway or other properly located opening may be used.

The chiller should be installed in an indoor location where temperatures range from 40°F to 104°F (4.4°C to 40°C). The dew point temperature in the equipment room must be below the entering condenser water temperature to prevent condensing water vapor inside of the low voltage VSD or low voltage SSS cabinet (if applicable). Applications using cooling sources other than evaporative or closed loop air exchange methods need to request a factory-supplied temperature control valve to prevent condensation inside the VSD or SSS cabinet. Other areas susceptible to water vapor condensate are outside of the condenser shell and condenser water boxes. Example applications include cooling condenser water using chilled water, wells, river or other low temperature fluids.

For outdoor applications, please contact Large Tonnage Application Team.

WATER CIRCUITS

Flow Rate – For normal water chilling duty, evaporator and condenser flow rates are permitted at water velocity levels in the heat exchangers tubes of between 3 fps (0.91 m/s) [3.3 fps (1.0 m/s) for condensers] and 12 fps (3.66 m/s). Two pass units are also limited to 45 ft H₂O (134 kPa) water pressure drop. The three pass limit is 67.5 ft H₂O (201 kPa).

Variable flow in the condenser is not recommended, as it generally raises the energy consumption of the system by keeping the condenser pressure high in the chiller. Additionally, the rate of fouling in the condenser will increase at lower water velocities associated with variable flow, raising system maintenance costs. Cooling towers typically have narrow ranges of operation with respect to flow rates, and will be more effective with full design flow. Ref. Tables 8 through 13 for flow limits at design conditions.

There is increasing interest to use variable primary flow (VPF) systems in large chilled water plants. VPF systems can offer lower installation and operating costs in many cases, but do require more sophisticated control and flow monitoring.

YORK YK Style G chillers will operate successfully in VPF systems. With a minimum allowable evaporator tube velocity of 1-1/2 fps (0.5 m/s) for standard tubes at part-load rat-

Application Data (Cont'd)

ing conditions, YK chillers will accommodate the wide variation in flow required by many chilled water VPF applications.

The chillers can tolerate a 50% flow rate change in one minute that is typically associated with the staging on or off of an additional chiller, however a lower flow rate change is normally used for better system stability and set point control. Proper sequencing via the building automation system will make this a very smooth transition.

Temperature Ranges – For normal water chilling duty, leaving chilled water temperatures may be selected between 38°F (3.3°C) [36°F (2.2°C) with Smart Freeze enabled] and 70°F (21.1°C) to obtain temperature deltas between entering chilled and leaving chilled water temperature of 3°F up to 30°F (1.7°C and 16.7°C).

Water Quality – The practical and economical application of liquid chillers requires that the quality of the water supply for the condenser and evaporator be analyzed by a water treatment specialist. Water quality may affect the performance of any chiller through corrosion, deposition of heat resistant scale, sedimentation or organic growth. These will degrade chiller performance and increase operating and maintenance costs. Normally, performance may be maintained by corrective water treatment and periodic cleaning of tubes. If water conditions exist which cannot be corrected by proper water treatment, it may be necessary to provide a larger allowance for fouling, and/or to specify special materials of construction.

General Piping – All chilled water and condenser water piping should be designed and installed in accordance with accepted piping practice. Chilled water and condenser water pumps should be located to discharge through the chiller to assure positive pressure and flow through the unit. Piping should include offsets to provide flexibility and should be arranged to prevent drainage of water from the evaporator and condenser when the pumps are shut off. Piping should be adequately supported and braced independently of the chiller to avoid the imposition of strain on chiller components. Hangers must allow for alignment of the pipe. Isolators in the piping and in the hangers are highly desirable in achieving sound and vibration control.

Convenience Considerations – To facilitate the performance of routine maintenance work, some or all of the following steps may be taken by the purchaser. Evaporator and condenser waterboxes are equipped with plugged vent and drain connections. If desired, vent and drain valves may be installed with or without piping to an open drain. Pressure gauges with stop cocks and stop valves may be installed in the inlets and outlets of the condenser and chilled water line as close as possible to the chiller. An overhead monorail or beam may be used to facilitate servicing.

Connections – The standard chiller is designed for 150 psig (10.3 barg) design working pressure in both the chilled water and condenser water circuits. The connections (water nozzles) to these circuits are furnished with grooves to ANSI/AWWA C-606 Standard for grooved and shouldered joints. Piping should be arranged for ease of disassembly at the unit for tube cleaning. All water piping should be thoroughly cleaned of all dirt and debris before final connections are made to the chiller.

Chilled Water – A water strainer of maximum 1/8" (3.2 mm) perforated holes must be field-installed in the chilled water inlet line as close as possible to the chiller. If located close enough to the chiller, the chilled water pump may be protected by the same strainer. The strainer is important to protect the chiller from debris or objects which could block flow through individual heat exchanger tubes. A reduction in flow through tubes could seriously impair the chiller performance or even result in tube freeze-up. A thermal-type flow switch is factory installed in the evaporator nozzle and connected to the OptiView panel, which assures adequate chilled water flow during operation.

Application Data (Cont'd)

TABLE 5 - WATER FLOW RATE LIMITS GPM (L/S) – BASED UPON STANDARD TUBES @ DESIGN FULL LOAD CONDITIONS

FLOODED EVAPORATORS							CONDENSER						
MODEL	1 PASS		2 PASS		3 PASS		MODEL	1 PASS		2 PASS		3 PASS	
	MIN	MAX	MIN	MAX	MIN	MAX		MIN	MAX	MIN	MAX	MIN	MAX
AP	329 (21)	1316 (83)	164 (10)	587 (37)	110 (7)	380 (24)	AP	479 (30)	1727 (109)	240 (15)	856 (54)	160 (10)	576 (36)
AQ	403 (25)	1613 (102)	202 (13)	713 (45)	134 (8)	460 (29)	AQ	612 (39)	2205 (139)	306 (19)	1068 (67)	204 (13)	732 (46)
AR	493 (31)	1973 (125)	247 (16)	861 (54)	164 (10)	552 (35)	AR	681 (43)	2455 (155)	341 (21)	1173 (74)	227 (14)	812 (51)
AS	602 (38)	2408 (152)	301 (19)	1032 (65)	201 (13)	655 (41)	AS	770 (49)	2773 (175)	385 (24)	1300 (82)	–	–
CP	648 (41)	2594 (164)	324 (20)	1151 (73)	216 (14)	755 (48)	CP	779 (49)	2807 (177)	389 (25)	1397 (88)	260 (16)	922 (58)
CQ	729 (46)	2917 (184)	365 (23)	1286 (81)	243 (15)	844 (53)	CQ	896 (57)	3228 (204)	448 (28)	1590 (100)	299 (19)	1050 (66)
CR	866 (55)	3463 (218)	433 (27)	1509 (95)	289 (18)	992 (63)	CR	1120 (71)	4035 (255)	560 (35)	1941 (122)	373 (24)	1285 (81)
CS	1043 (66)	4170 (263)	521 (33)	1787 (113)	348 (22)	1176 (74)	CS	1397 (88)	5035 (318)	699 (44)	2340 (148)	–	–
DP	648 (41)	2594 (164)	324 (20)	988 (62)	216 (14)	648 (41)	DP	779 (49)	2807 (177)	389 (25)	1203 (76)	260 (16)	793 (50)
DQ	729 (46)	2917 (184)	365 (23)	1106 (70)	243 (15)	725 (46)	DQ	896 (57)	3228 (204)	448 (28)	1372 (87)	299 (19)	906 (57)
DR	866 (55)	3463 (218)	433 (27)	1301 (82)	289 (18)	854 (54)	DR	1120 (71)	4035 (255)	560 (35)	1685 (106)	373 (24)	1114 (70)
DS	1043 (66)	4170 (263)	521 (33)	1547 (98)	348 (22)	1017 (64)	DS	1397 (88)	5035 (318)	699 (44)	2048 (129)	–	–
EP	859 (54)	3438 (217)	430 (27)	1535 (97)	286 (18)	1009 (64)	EP	1120 (71)	4035 (255)	560 (35)	2017 (127)	373 (24)	1337 (84)
EQ	1046 (66)	4183 (264)	523 (33)	1853 (117)	349 (22)	1220 (77)	EQ	1344 (85)	4842 (305)	672 (42)	2394 (151)	448 (28)	1590 (100)
ER	1232 (78)	4927 (311)	616 (39)	2164 (136)	411 (26)	1428 (90)	ER	1583 (100)	5705 (360)	792 (50)	2779 (175)	528 (33)	1853 (117)
ES	1452 (92)	5809 (366)	726 (46)	2519 (159)	484 (31)	1667 (105)	ES	1750 (110)	6308 (398)	875 (55)	3037 (192)	583 (37)	2031 (128)
ET	1676 (106)	6702 (423)	838 (53)	2865 (181)	559 (35)	1903 (120)	ET	1946 (123)	7012 (442)	973 (61)	3328 (210)	–	–
FQ	1046 (66)	4183 (264)	523 (33)	1591 (100)	349 (22)	1046 (66)	FQ	1344 (85)	4842 (305)	672 (42)	2064 (130)	448 (28)	1368 (86)
FR	1232 (78)	4927 (311)	616 (39)	1862 (117)	411 (26)	1226 (77)	FR	1583 (100)	5705 (360)	792 (50)	2405 (152)	528 (33)	1599 (101)
FS	1452 (92)	5809 (366)	726 (46)	2175 (137)	484 (31)	1436 (91)	FS	1750 (110)	6308 (398)	875 (55)	2636 (166)	583 (37)	1756 (111)
FT	1676 (106)	6702 (423)	838 (53)	2482 (157)	559 (35)	1643 (104)	FT	1946 (123)	7012 (442)	973 (61)	2898 (183)	–	–
GQ	1443 (91)	5771 (364)	721 (46)	2504 (158)	481 (30)	1657 (105)	EV	1583 (100)	5705 (360)	792 (50)	2779 (175)	528 (33)	1853 (117)
GR	1629 (103)	6516 (411)	814 (51)	2794 (176)	543 (34)	1855 (117)	EW	1750 (110)	6308 (398)	875 (55)	3037 (192)	583 (37)	2031 (128)
GS	1843 (116)	7372 (465)	922 (58)	3115 (197)	614 (39)	2075 (131)	EX	1946 (123)	7012 (442)	973 (61)	3328 (210)	–	–

Application Data (Cont'd)

TABLE 5 - WATER FLOW RATE LIMITS GPM (L/S) – BASED UPON STANDARD TUBES @ DESIGN FULL LOAD CONDITIONS (CONT'D)

FLOODED EVAPORATORS							CONDENSER						
MODEL	1 PASS		2 PASS		3 PASS		MODEL	1 PASS		2 PASS		3 PASS	
	MIN	MAX	MIN	MAX	MIN	MAX		MIN	MAX	MIN	MAX	MIN	MAX
	–	–	–	–	–	–	E3	1416 (89)	5101 (322)	708 (45)	2551 (161)	472 (30)	1700 (107)
	–	–	–	–	–	–	E4	1738 (110)	6263 (395)	869 (55)	3131 (198)	–	–
HQ	1443 (91)	5771 (364)	721 (46)	2162 (136)	481 (30)	1427 (90)	FV	1583 (100)	5705 (360)	792 (50)	2405 (152)	528 (33)	1599 (101)
HR	1629 (103)	6516 (411)	814 (51)	2419 (153)	543 (34)	1600 (101)	FW	1750 (110)	6308 (398)	875 (55)	2636 (166)	583 (37)	1756 (111)
HS	1843 (116)	7372 (465)	922 (58)	2707 (171)	614 (39)	1796 (113)	FX	1946 (123)	7012 (442)	973 (61)	2898 (183)	–	–
	–	–	–	–	–	–	F3	1416 (89)	5101 (322)	708 (45)	2551 (161)	472 (30)	1700 (107)
	–	–	–	–	–	–	F4	1738 (110)	6263 (395)	869 (55)	3131 (198)	–	–
JP	1545 (97)	6181 (390)	773 (49)	2735 (173)	515 (32)	1807 (114)	JP	1583 (100)	5705 (360)	792 (50)	2779 (175)	528 (33)	1899 (120)
JQ	1918 (121)	7670 (484)	959 (60)	3349 (211)	639 (40)	2224 (140)	JQ	1892 (119)	6819 (430)	946 (60)	3249 (205)	631 (40)	2253 (142)
JR	2395 (151)	9582 (604)	1198 (76)	4098 (259)	798 (50)	2742 (173)	JR	2479 (156)	8933 (564)	1239 (78)	4054 (256)	826 (52)	2903 (183)
JS	2616 (165)	10463 (660)	1308 (83)	4427 (279)	872 (55)	2974 (188)	JS	2756 (174)	9933 (627)	1378 (87)	4395 (277)	–	–
KP, KT	1545 (97)	6181 (390)	773 (49)	2522 (159)	515 (32)	1664 (105)	KP	1583 (100)	5705 (360)	792 (50)	2574 (162)	528 (33)	1750 (110)
KQ, KV	1918 (121)	7670 (484)	959 (60)	3094 (195)	639 (40)	2051 (129)	KQ	1892 (119)	6819 (430)	946 (60)	3019 (190)	631 (40)	2078 (131)
KR, KW	2395 (151)	9582 (604)	1198 (76)	3797 (240)	798 (50)	2533 (160)	KR	2479 (156)	8933 (564)	1239 (78)	3790 (239)	826 (52)	2684 (169)
KS, KX	2616 (165)	10463 (660)	1308 (83)	4109 (259)	872 (55)	2750 (174)	KS	2756 (174)	9933 (627)	1378 (87)	4121 (260)	–	–
K2, K5	1844 (116)	7374 (465)	922 (58)	3687 (233)	615 (39)	2458 (155)	K2	1617 (102)	5829 (368)	809 (51)	2914 (184)	539 (34)	1943 (123)
K3, K6	2163 (136)	8651 (546)	1081 (68)	4325 (273)	721 (45)	2884 (182)	K3	1927 (122)	6946 (438)	964 (61)	3473 (219)	642 (41)	2315 (146)
K4, K7	2488 (157)	9951 (628)	1244 (78)	4903 (309)	829 (52)	3312 (209)	K4	2584 (163)	9313 (588)	1292 (82)	4657 (294)	–	–
LQ	1918 (121)	7670 (484)	959 (60)	2886 (182)	639 (40)	1910 (120)	LQ	1892 (119)	6819 (430)	946 (60)	2827 (178)	631 (40)	1936 (122)
LR	2395 (151)	9582 (604)	1198 (76)	3550 (224)	798 (50)	2363 (149)	LR	2479 (156)	8933 (564)	1239 (78)	3567 (225)	826 (52)	2504 (158)
LS	2616 (165)	10463 (660)	1308 (83)	3845 (243)	872 (55)	2567 (162)	LS	2756 (174)	9933 (627)	1378 (87)	3888 (245)	–	–
	–	–	–	–	–	–	MP	2192 (138)	7899 (498)	1096 (69)	3626 (229)	731 (46)	2391 (151)
MQ	2426 (153)	9706 (612)	1213 (77)	3906 (246)	809 (51)	2606 (164)	MQ	2570 (162)	9263 (584)	1285 (81)	4206 (265)	857 (54)	2776 (175)
MR	2830 (179)	11319 (714)	1415 (89)	4499 (284)	943 (60)	3022 (191)	MR	2949 (186)	10626 (670)	1474 (93)	4765 (301)	983 (62)	3149 (199)

Application Data (Cont'd)

TABLE 5 - WATER FLOW RATE LIMITS GPM (L/S) – BASED UPON STANDARD TUBES @ DESIGN FULL LOAD CONDITIONS (CONT'D)

FLOODED EVAPORATORS							CONDENSER						
MODEL	1 PASS		2 PASS		3 PASS		MODEL	1 PASS		2 PASS		3 PASS	
	MIN	MAX	MIN	MAX	MIN	MAX		MIN	MAX	MIN	MAX	MIN	MAX
MS	3246 (205)	12982 (819)	1623 (102)	5088 (321)	1082 (68)	3444 (217)	MS	3271 (206)	11786 (744)	1635 (103)	5225 (330)	-	-
M2	2003 (126)	8013 (506)	1002 (63)	4006 (253)	668 (42)	2671 (169)	M2	2131 (134)	7678 (484)	1065 (67)	3839 (242)	710 (45)	2559 (161)
M3	2375 (150)	9502 (599)	1188 (75)	4751 (300)	792 (50)	3167 (200)	M3	2639 (166)	9510 (600)	1319 (83)	4755 (300)	880 (55)	3170 (200)
M4	2949 (186)	11794 (744)	1474 (93)	5837 (368)	983 (62)	3931 (248)	M4	3246 (205)	11699 (738)	1623 (102)	5849 (369)	-	-
	-	-	-	-	-	-	NP	2192 (138)	7899 (498)	1096 (69)	3381 (213)	731 (46)	2229 (141)
NQ	2426 (153)	9706 (612)	1213 (77)	3644 (230)	809 (51)	2426 (153)	NQ	2570 (162)	9263 (584)	1285 (81)	3927 (248)	857 (54)	2591 (163)
NR	2830 (179)	11319 (714)	1415 (89)	4205 (265)	943 (60)	2815 (178)	NR	2949 (186)	10626 (670)	1474 (93)	4456 (281)	983 (62)	2943 (186)
NS	3246 (205)	12982 (819)	1623 (102)	4763 (300)	1082 (68)	3210 (203)	NS	3271 (206)	11786 (744)	1635 (103)	4892 (309)	-	-
N2	2003 (126)	8013 (506)	1002 (63)	3870 (244)	668 (42)	2580 (163)	N2	2131 (134)	7678 (484)	1065 (67)	3839 (242)	710 (45)	2559 (161)
N3	2375 (150)	9502 (599)	1188 (75)	4527 (286)	792 (50)	3040 (192)	N3	2639 (166)	9510 (600)	1319 (83)	4755 (300)	880 (55)	3170 (200)
N4	2949 (186)	11794 (744)	1474 (93)	5484 (346)	983 (62)	3731 (235)	N4	3246 (205)	11699 (738)	1623 (102)	5849 (369)	-	-
PQ	2755 (174)	11021 (695)	1378 (87)	4391 (277)	918 (58)	2946 (186)	PQ	3662 (231)	13195 (832)	1831 (116)	5954 (376)	1221 (77)	4003 (253)
PR	3131 (198)	12523 (790)	1565 (99)	4928 (311)	1044 (66)	3328 (210)	PR	4097 (258)	14763 (931)	2048 (129)	6587 (416)	1366 (86)	4452 (281)
PS	3360 (212)	13441 (848)	1680 (106)	5246 (331)	1120 (71)	3558 (224)	PS	4545 (287)	16377 (1033)	2272 (143)	7216 (455)	-	-
P2	2523 (159)	10093 (637)	1262 (80)	5046 (318)	841 (53)	3364 (212)	P2	3229 (204)	11635 (734)	1614 (102)	5817 (367)	1076 (68)	3878 (245)
P3	2960 (187)	11842 (747)	1480 (93)	5857 (370)	987 (62)	3947 (249)	P3	3917 (247)	14114 (890)	1958 (124)	7057 (445)	1306 (82)	4705 (297)
P4	3356 (212)	13425 (847)	1678 (106)	6499 (410)	1119 (71)	4475 (282)	P4	4760 (300)	17152 (1082)	2380 (150)	8576 (541)	-	-
QQ	2755 (174)	11021 (695)	1378 (87)	4103 (259)	918 (58)	2744 (173)	QQ	3662 (231)	13195 (832)	1831 (116)	5563 (351)	1221 (77)	3731 (235)
QR	3131 (198)	12523 (790)	1565 (99)	4611 (291)	1044 (66)	3102 (196)	QR	4097 (258)	14763 (931)	2048 (129)	6163 (389)	1366 (86)	4152 (262)
QS	3360 (212)	13441 (848)	1680 (106)	4913 (310)	1120 (71)	3318 (209)	QS	4545 (287)	16377 (1033)	2272 (143)	6762 (427)	-	-
Q2	2523 (159)	10093 (637)	1262 (80)	4780 (302)	841 (53)	3221 (203)	Q2	3229 (204)	11635 (734)	1614 (102)	5817 (367)	1076 (68)	3878 (245)
Q3	2960 (187)	11842 (747)	1480 (93)	5503 (347)	987 (62)	3745 (236)	Q3	3917 (247)	14114 (890)	1958 (124)	7057 (445)	1306 (82)	4705 (297)
Q4	3356 (212)	13425 (847)	1678 (106)	6121 (386)	1119 (71)	4207 (265)	Q4	4760 (300)	17152 (1082)	2380 (150)	8576 (541)	-	-
QT	3602 (227)	14410 (909)	1801 (114)	5225 (330)	1201 (76)	3544 (224)		-	-	-	-	-	-

Application Data (Cont'd)

TABLE 5 - WATER FLOW RATE LIMITS GPM (L/S) – BASED UPON STANDARD TUBES @ DESIGN FULL LOAD CONDITIONS (CONT'D)

FLOODED EVAPORATORS							CONDENSER						
MODEL	1 PASS		2 PASS		3 PASS		MODEL	1 PASS		2 PASS		3 PASS	
	MIN	MAX	MIN	MAX	MIN	MAX		MIN	MAX	MIN	MAX	MIN	MAX
QV	4142 (261)	16569 (1045)	2071 (131)	5893 (372)	1381 (87)	4037 (255)		-	-	-	-	-	-
RQ	3770 (238)	15080 (951)	1885 (119)	5689 (359)	1257 (79)	3737 (236)	RQ	4907 (310)	17684 (1116)	2454 (155)	7428 (469)	1636 (103)	4917 (310)
RS	4605 (291)	18418 (1162)	2302 (145)	6863 (433)	1535 (97)	4517 (285)	RR	5390 (340)	19423 (1225)	2695 (170)	8086 (510)	1797 (113)	5360 (338)
RV	5405 (341)	21621 (1364)	2703 (171)	7946 (501)	1802 (114)	5240 (331)	RS	5753 (363)	20730 (1308)	2876 (181)	8570 (541)	-	-
R3	3870 (244)	15482 (977)	1935 (122)	7403 (467)	1290 (81)	4872 (307)	R2	4228 (267)	15235 (961)	2114 (133)	7618 (481)	1409 (89)	5078 (320)
R5	4603 (290)	18413 (1162)	2302 (145)	8650 (546)	1534 (97)	5708 (360)	R3	4996 (315)	18005 (1136)	2498 (158)	9002 (568)	1665 (105)	6002 (379)
R7	5241 (331)	20965 (1323)	2621 (165)	9682 (611)	1747 (110)	6404 (404)	R4	5914 (373)	21311 (1344)	2957 (187)	10655 (672)	-	-
RP	3103 (196)	12411 (783)	1551 (98)	4722 (298)	1034 (65)	3098 (195)		-	-	-	-	-	-
RR	3829 (242)	15316 (966)	1914 (121)	5774 (364)	1276 (81)	3793 (239)		-	-	-	-	-	-
RT	4633 (292)	18530 (1169)	2316 (146)	6902 (435)	1544 (97)	4542 (287)		-	-	-	-	-	-
R2	3800 (240)	15198 (959)	1900 (120)	7278 (459)	1267 (80)	4789 (302)		-	-	-	-	-	-
R4	4296 (271)	17183 (1084)	2148 (136)	8135 (513)	1432 (90)	5362 (338)		-	-	-	-	-	-
R6	4816 (304)	19263 (1215)	2408 (152)	9000 (568)	1605 (101)	5943 (375)		-	-	-	-	-	-
SQ	3770 (238)	15080 (951)	1885 (119)	5345 (337)	1257 (79)	3510 (221)	SQ	4907 (310)	17684 (1116)	2454 (155)	6992 (441)	1636 (103)	4626 (292)
SS	4605 (291)	18418 (1162)	2302 (145)	6457 (407)	1535 (97)	4247 (268)	SR	5390 (340)	19423 (1225)	2695 (170)	7619 (481)	1797 (113)	5047 (318)
SV	5405 (341)	21621 (1364)	2703 (171)	7487 (472)	1802 (114)	4933 (311)	SS	5753 (363)	20730 (1308)	2876 (181)	8081 (510)	-	-
S3	3870 (244)	15482 (977)	1935 (122)	6975 (440)	1290 (81)	4588 (289)	S2	4228 (267)	15235 (961)	2114 (133)	7549 (476)	1409 (89)	4993 (315)
S5	4603 (290)	18413 (1162)	2302 (145)	8166 (515)	1534 (97)	5384 (340)	S3	4996 (315)	18005 (1136)	2498 (158)	8795 (555)	1665 (105)	5832 (368)
S7	5241 (331)	20965 (1323)	2621 (165)	9157 (578)	1747 (110)	6050 (382)	S4	5914 (373)	21311 (1344)	2957 (187)	10192 (643)	-	-
	-	-	-	-	-	-	TP	5396 (340)	19446 (1227)	2698 (170)	8095 (511)	1799 (113)	5470 (345)
	-	-	-	-	-	-	TQ	5973 (377)	21525 (1358)	2987 (188)	8859 (559)	1991 (126)	6020 (380)
	-	-	-	-	-	-	TR	6576 (415)	23696 (1495)	3288 (207)	9629 (607)	2192 (138)	6583 (415)
	-	-	-	-	-	-	TS	6929 (437)	24969 (1575)	3464 (219)	10067 (635)	-	-
	-	-	-	-	-	-	T2	4607 (291)	16602 (1047)	2304 (145)	8301 (524)	1536 (97)	5534 (349)

Application Data (Cont'd)

TABLE 5 - WATER FLOW RATE LIMITS GPM (L/S) – BASED UPON STANDARD TUBES @ DESIGN FULL LOAD CONDITIONS (CONT'D)

FLOODED EVAPORATORS							CONDENSER						
MODEL	1 PASS		2 PASS		3 PASS		MODEL	1 PASS		2 PASS		3 PASS	
	MIN	MAX	MIN	MAX	MIN	MAX		MIN	MAX	MIN	MAX	MIN	MAX
	–	–	–	–	–	–	T3	5710 (360)	20578 (1298)	2855 (180)	10289 (649)	1903 (120)	6859 (433)
	–	–	–	–	–	–	T4	6299 (397)	22700 (1432)	3150 (199)	11300 (713)	2100 (132)	7567 (477)
	–	–	–	–	–	–	T5	7093 (447)	25559 (1613)	3546 (224)	12421 (784)	–	–
	–	–	–	–	–	–	VP	5396 (340)	19446 (1227)	2698 (170)	7628 (481)	1799 (113)	5140 (324)
	–	–	–	–	–	–	VQ	5973 (377)	21525 (1358)	2987 (188)	8358 (527)	1991 (126)	5660 (357)
	–	–	–	–	–	–	VR	6576 (415)	23696 (1495)	3288 (207)	9097 (574)	2192 (138)	6194 (391)
	–	–	–	–	–	–	VS	6929 (437)	24969 (1575)	3464 (219)	9518 (600)	–	–
	–	–	–	–	–	–	V2	4607 (291)	16602 (1047)	2304 (145)	8143 (514)	1536 (97)	5497 (347)
	–	–	–	–	–	–	V3	5710 (360)	20578 (1298)	2855 (180)	9865 (622)	1903 (120)	6749 (426)
	–	–	–	–	–	–	V4	6299 (397)	22700 (1432)	3150 (199)	10725 (677)	2100 (132)	7395 (467)
	–	–	–	–	–	–	V5	7093 (447)	25559 (1613)	3546 (224)	11818 (746)	–	–
WP	3103 (196)	12411 (783)	1551 (98)	3973 (251)	1034 (65)	2605 (164)	WQ	5368 (339)	19343 (1220)	2684 (169)	6844 (432)	1789 (113)	4591 (290)
WR	3829 (242)	15316 (966)	1914 (121)	4871 (307)	1276 (81)	3197 (202)	WR	5891 (372)	21230 (1339)	2946 (186)	7456 (470)	1964 (124)	5020 (317)
WT	4633 (292)	18530 (1169)	2316 (146)	5842 (369)	1544 (97)	3840 (242)	WS	6415 (405)	23117 (1458)	3207 (202)	8054 (508)	–	–
W1	3173 (200)	12693 (801)	1587 (100)	5209 (329)	1058 (67)	3419 (216)	W1	4250 (268)	15314 (966)	2125 (134)	6785 (428)	1417 (89)	4540 (286)
W2	3800 (240)	15198 (959)	1900 (120)	6180 (390)	1267 (80)	4062 (256)	W2	5260 (332)	18955 (1196)	2630 (166)	8290 (523)	1753 (111)	5603 (354)
W4	4296 (271)	17183 (1084)	2148 (136)	6929 (437)	1432 (90)	4559 (288)	W3	6140 (387)	22127 (1396)	3070 (194)	9526 (601)	2047 (129)	6502 (410)
W6	4816 (304)	19263 (1215)	2408 (152)	7693 (485)	1605 (101)	5069 (320)	W4	6785 (428)	24450 (1543)	3392 (214)	10386 (655)	–	–
XQ	4769 (301)	19076 (1204)	2385 (150)	7089 (447)	1590 (100)	4667 (294)	XQ	6241 (394)	22491 (1419)	3121 (197)	9429 (595)	2080 (131)	6272 (396)
XR	5272 (333)	21087 (1330)	2636 (166)	7769 (490)	1757 (111)	5121 (323)	XR	6967 (440)	25105 (1584)	3483 (220)	10411 (657)	2322 (147)	6943 (438)
XS	5740 (362)	22961 (1449)	2870 (181)	8386 (529)	1913 (121)	5534 (349)	XS	7900 (498)	28470 (1796)	3950 (249)	11627 (734)	–	–
X2	4769 (301)	19074 (1203)	2384 (150)	8923 (563)	1590 (100)	5891 (372)	X2	4969 (313)	17905 (1130)	2484 (157)	8952 (565)	1656 (104)	5968 (377)
X3	5637 (356)	22549 (1423)	2819 (178)	10296 (650)	1879 (119)	6820 (430)	X3	6487 (409)	23378 (1475)	3244 (205)	11689 (737)	2162 (136)	7793 (492)
X4	6281 (396)	25125 (1585)	3141 (198)	11250 (710)	2094 (132)	7470 (471)	X4	8099 (511)	29185 (1841)	4049 (255)	14441 (911)	–	–

Application Data (Cont'd)

TABLE 5 - WATER FLOW RATE LIMITS GPM (L/S) – BASED UPON STANDARD TUBES @ DESIGN FULL LOAD CONDITIONS (CONT'D)

FLOODED EVAPORATORS							CONDENSER						
MODEL	1 PASS		2 PASS		3 PASS		MODEL	1 PASS		2 PASS		3 PASS	
	MIN	MAX	MIN	MAX	MIN	MAX		MIN	MAX	MIN	MAX	MIN	MAX
ZQ	4769 (301)	19076 (1204)	2385 (150)	6671 (421)	1590 (100)	4390 (277)	ZQ	6241 (394)	22491 (1419)	3121 (197)	8878 (560)	2080 (131)	5899 (372)
ZR	5272 (333)	21087 (1330)	2636 (166)	7318 (462)	1757 (111)	4820 (304)	ZR	6967 (440)	25105 (1584)	3483 (220)	9814 (619)	2322 (147)	6536 (412)
ZS	5740 (362)	22961 (1449)	2870 (181)	7907 (499)	1913 (121)	5214 (329)	ZS	7900 (498)	28470 (1796)	3950 (249)	10978 (693)	–	–
Z1	3959 (250)	15836 (999)	1980 (125)	7122 (449)	1320 (83)	4686 (296)	Z1	4138 (261)	14912 (941)	2069 (131)	7435 (469)	1379 (87)	4914 (310)
Z2	4769 (301)	19074 (1203)	2384 (150)	8427 (532)	1590 (100)	5559 (351)	Z2	4969 (313)	17905 (1130)	2484 (157)	8866 (559)	1656 (104)	5880 (371)
Z3	5637 (356)	22549 (1423)	2819 (178)	9748 (615)	1879 (119)	6450 (407)	Z3	6487 (409)	23378 (1475)	3244 (205)	11332 (715)	2162 (136)	7567 (477)
Z4	6281 (396)	25125 (1585)	3141 (198)	10672 (673)	2094 (132)	7077 (447)	Z4	8099 (511)	29185 (1841)	4049 (255)	13715 (865)	–	–

Application Data (Cont'd)

TABLE 6 - WATER FLOW RATE LIMITS GPM (L/S) – BASED UPON STANDARD TUBES @ DESIGN FULL LOAD CONDITIONS

MODEL	HEAT RECOVERY CONDENSER - TOWER BUNDLE						HEAT RECOVERY CONDENSER - HEATING BUNDLE					
	1 PASS		2 PASS		3 PASS		1 PASS		2 PASS		3 PASS	
	MIN	MAX	MIN	MAX	MIN	MAX	MIN	MAX	MIN	MAX	MIN	MAX
BW	1435 (91)	5171 (326)	717 (45)	2392 (151)	478 (30)	1590 (100)	555 (35)	2000 (126)	278 (18)	1000 (63)	185 (12)	665 (42)
BX	1435 (91)	5171 (326)	717 (45)	2392 (151)	478 (30)	1590 (100)	861 (54)	3103 (196)	430 (27)	1529 (96)	287 (18)	1010 (64)
IW	2123 (134)	7649 (483)	1061 (67)	3579 (226)	708 (45)	2409 (152)	763 (48)	2750 (174)	382 (24)	1367 (86)	254 (16)	917 (58)
IX	2123 (134)	7649 (483)	1061 (67)	3579 (226)	708 (45)	2409 (152)	1344 (85)	4842 (305)	672 (42)	2260 (143)	448 (28)	1586 (100)
OW	3129 (197)	11274 (711)	1564 (99)	4892 (309)	1043 (66)	3322 (210)	940 (59)	3387 (214)	470 (30)	1571 (99)	313 (20)	1038 (65)
OX	3129 (197)	11274 (711)	1564 (99)	4892 (309)	1043 (66)	3322 (210)	1984 (125)	7149 (451)	992 (63)	3138 (198)	661 (42)	2102 (133)
O8	3053 (193)	11002 (694)	1527 (96)	5501 (347)	1018 (64)	3667 (231)	1122 (71)	4043 (255)	561 (35)	2021 (128)	374 (24)	1348 (85)
O9	3053 (193)	11002 (694)	1527 (96)	5501 (347)	1018 (64)	3667 (231)	1791 (113)	6455 (407)	896 (57)	3228 (204)	597 (38)	2152 (136)
UW	3293 (208)	11865 (749)	1646 (104)	5256 (332)	1098 (69)	3477 (219)	1069 (67)	3853 (243)	535 (34)	1799 (113)	356 (22)	1188 (75)
UX	3293 (208)	11865 (749)	1646 (104)	5256 (332)	1098 (69)	3477 (219)	2091 (132)	7535 (475)	1045 (66)	3415 (215)	697 (44)	2281 (144)
U8	3403 (215)	12263 (774)	1701 (107)	6131 (387)	1134 (72)	4088 (258)	1178 (74)	4244 (268)	589 (37)	2122 (134)	393 (25)	1415 (89)
U9	3403 (215)	12263 (774)	1701 (107)	6131 (387)	1134 (72)	4088 (258)	1891 (119)	6813 (430)	945 (60)	3406 (215)	630 (40)	2271 (143)
YW	7705 (486)	27765 (1752)	3852 (243)	10738 (677)	2568 (162)	7169 (452)	2596 (164)	9353 (590)	1298 (82)	3797 (240)	865 (55)	2513 (159)
YX	7705 (486)	27765 (1752)	3852 (243)	10738 (677)	2568 (162)	7169 (452)	4917 (310)	17718 (1118)	2458 (155)	6991 (441)	1639 (103)	4693 (296)
Y8	7963 (502)	28696 (1810)	3982 (251)	13330 (841)	2654 (167)	8951 (565)	3236 (204)	11660 (736)	1618 (102)	5830 (368)	1079 (68)	3887 (245)
Y9	7963 (502)	28696 (1810)	3982 (251)	13330 (841)	2654 (167)	8951 (565)	5244 (331)	18897 (1192)	2622 (165)	9287 (586)	1748 (110)	6299 (397)

Application Data (Cont'd)

TABLE 7 - WATER FLOW RATE LIMITS GPM (L/S) - BASED UPON STANDARD TUBES @ DESIGN FULL LOAD CONDITIONS

HYBRID FALLING FILM EVAPORATORS						
MODEL	1 PASS		2 PASS		3 PASS	
	MIN	MAX	MIN	MAX	MIN	MAX
AC	705 (44)	2819 (178)	352 (22)	1194 (75)	235 (15)	825 (52)
AD	882 (56)	3527 (223)	441 (28)	1436 (91)	294 (19)	1018 (64)
A3	674 (43)	2695 (170)	337 (21)	1347 (85)	225 (14)	898 (57)
A4	812 (51)	3248 (205)	406 (26)	1624 (102)	271 (17)	1083 (68)
CC	796 (50)	3186 (201)	398 (25)	1410 (89)	265 (17)	945 (60)
CD	999 (63)	3995 (252)	499 (32)	1734 (109)	333 (21)	1178 (74)
CE	1270 (80)	5082 (321)	635 (40)	2140 (135)	423 (27)	1484 (94)
C3	746 (47)	2983 (188)	373 (24)	1492 (94)	249 (16)	994 (63)
C4	938 (59)	3753 (237)	469 (30)	1877 (118)	313 (20)	1251 (79)
C5	1221 (77)	4884 (308)	611 (39)	2442 (154)	407 (26)	1628 (103)
DC	796 (50)	3186 (201)	398 (25)	1214 (77)	265 (17)	809 (51)
DD	999 (63)	3995 (252)	499 (32)	1501 (95)	333 (21)	1010 (64)
DE	1270 (80)	5082 (321)	635 (40)	1865 (118)	423 (27)	1275 (80)
D3	746 (47)	2983 (188)	373 (24)	1463 (92)	249 (16)	982 (62)
D4	938 (59)	3753 (237)	469 (30)	1803 (114)	313 (20)	1228 (77)
D5	1221 (77)	4884 (308)	611 (39)	2261 (143)	407 (26)	1578 (100)
EC	980 (62)	3919 (247)	490 (31)	1758 (111)	327 (21)	1168 (74)
ED	1296 (82)	5183 (327)	648 (41)	2289 (144)	432 (27)	1537 (97)
EE	1637 (103)	6548 (413)	819 (52)	2831 (179)	546 (34)	1929 (122)
E3	986 (62)	3946 (249)	493 (31)	1973 (124)	329 (21)	1315 (83)

Application Data (Cont'd)

TABLE 8 - TABLE 8 - WATER FLOW RATE LIMITS GPM (L/S) - BASED UPON STANDARD TUBES @ DESIGN FULL LOAD CONDITIONS

HYBRID FALLING FILM EVAPORATORS						
MODEL	1 PASS		2 PASS		3 PASS	
	MIN	MAX	MIN	MAX	MIN	MAX
E4	1233 (78)	4932 (311)	617 (39)	2466 (156)	411 (26)	1644 (104)
E5	1522 (96)	6087 (384)	761 (48)	3044 (192)	507 (32)	2029 (128)
FC	980 (62)	3919 (247)	490 (31)	1508 (95)	327 (21)	998 (63)
FD	1296 (82)	5183 (327)	648 (41)	1972 (124)	432 (27)	1316 (83)
FE	1637 (103)	6548 (413)	819 (52)	2452 (155)	546 (34)	1654 (104)
F3	986 (62)	3946 (249)	493 (31)	1956 (123)	329 (21)	1304 (82)
F4	1233 (78)	4932 (311)	617 (39)	2410 (152)	411 (26)	1622 (102)
F5	1522 (96)	6087 (384)	761 (48)	2914 (184)	507 (32)	1989 (125)
GC	1293 (82)	5170 (326)	646 (41)	2284 (144)	431 (27)	1533 (97)
GD	1618 (102)	6472 (408)	809 (51)	2802 (177)	539 (34)	1907 (120)
GE	2108 (133)	8432 (532)	1054 (66)	3521 (222)	703 (44)	2455 (155)
G3	1269 (80)	5077 (320)	635 (40)	2538 (160)	423 (27)	1692 (107)
G4	1588 (100)	6352 (401)	794 (50)	3176 (200)	529 (33)	2117 (134)
G5	1973 (124)	7892 (498)	986 (62)	3946 (249)	658 (41)	2631 (166)
HC	1293 (82)	5170 (326)	646 (41)	1967 (124)	431 (27)	1312 (83)
HD	1618 (102)	6472 (408)	809 (51)	2426 (153)	539 (34)	1635 (103)
HE	2108 (133)	8432 (532)	1054 (66)	3075 (194)	703 (44)	2112 (133)
H3	1269 (80)	5077 (320)	635 (40)	2474 (156)	423 (27)	1668 (105)
H4	1588 (100)	6352 (401)	794 (50)	3025 (191)	529 (33)	2072 (131)
H5	1973 (124)	7892 (498)	986 (62)	3637 (229)	658 (41)	2546 (161)
KC	2117 (134)	8470 (534)	1059 (67)	3424 (216)	706 (45)	2305 (145)

Application Data (Cont'd)

TABLE 8 - WATER FLOW RATE LIMITS GPM (L/S) - BASED UPON STANDARD TUBES @ DESIGN FULL LOAD CONDITIONS (CONT'D)

HYBRID FALLING FILM EVAPORATORS						
MODEL	1 PASS		2 PASS		3 PASS	
	MIN	MAX	MIN	MAX	MIN	MAX
KD	2784 (176)	11137 (703)	1392 (88)	4378 (276)	928 (59)	3004 (190)
K8	1540 (97)	6159 (389)	770 (49)	3080 (194)	513 (32)	2053 (130)
K9	2057 (130)	8228 (519)	1029 (65)	4114 (260)	686 (43)	2743 (173)
K0	2695 (170)	10779 (680)	1347 (85)	5316 (335)	898 (57)	3593 (227)
IB	2124 (134)	8496 (536)	1062 (67)	3274 (207)	707 (45)	2170 (137)
ID	2378 (150)	9510 (600)	1189 (75)	3633 (229)	793 (50)	2419 (153)
IF	2793 (176)	11171 (705)	1395 (88)	4193 (265)	929 (59)	2807 (177)
IH	2916 (184)	11666 (736)	1458 (92)	4360 (275)	-	-
I2	1547 (98)	6187 (390)	773 (49)	3093 (195)	514 (32)	2054 (130)
I4	1812 (114)	7250 (457)	906 (57)	3606 (228)	604 (38)	2399 (151)
I6	2066 (130)	8265 (521)	1033 (65)	4060 (256)	689 (43)	2713 (171)
I8	2864 (181)	11455 (723)	1432 (90)	5367 (339)	-	-
MB	2479 (156)	9916 (626)	1239 (78)	3833 (242)	824 (52)	2550 (161)
MD	2891 (182)	11564 (730)	1446 (91)	4418 (279)	964 (61)	2965 (187)
MF	3370 (213)	13479 (850)	1683 (106)	5067 (320)	-	-
M5	2048 (129)	8192 (517)	1021 (64)	4084 (258)	683 (43)	2731 (172)
M7	2429 (153)	9715 (613)	1214 (77)	4790 (302)	810 (51)	3226 (204)
M8	3015 (190)	12059 (761)	1504 (95)	5780 (365)	1003 (63)	3947 (249)
M9	3420 (216)	13678 (863)	1710 (108)	6434 (406)	-	-
NB	2479 (156)	9916 (626)	1239 (78)	3577 (226)	824 (52)	2374 (150)
ND	2891 (182)	11564 (730)	1446 (91)	4129 (261)	964 (61)	2763 (174)

Application Data (Cont'd)

TABLE 8 - WATER FLOW RATE LIMITS GPM (L/S) - BASED UPON STANDARD TUBES @ DESIGN FULL LOAD CONDITIONS (CONT'D)

HYBRID FALLING FILM EVAPORATORS						
MODEL	1 PASS		2 PASS		3 PASS	
	MIN	MAX	MIN	MAX	MIN	MAX
NF	3370 (213)	13479 (850)	1683 (106)	4744 (299)	-	-
N5	2048 (129)	8192 (517)	1021 (64)	3827 (241)	683 (43)	2558 (161)
N7	2429 (153)	9715 (613)	1214 (77)	4492 (283)	810 (51)	3015 (190)
N8	3015 (190)	12059 (761)	1504 (95)	5437 (343)	1003 (63)	3695 (233)
N9	3420 (216)	13678 (863)	1710 (108)	6065 (383)	-	-
PB	2815 (178)	11260 (710)	1407 (89)	4312 (272)	938 (59)	2890 (182)
PD	3199 (202)	12794 (807)	1598 (101)	4837 (305)	1065 (67)	3263 (206)
PF	3680 (232)	14722 (929)	1839 (116)	5639 (356)	1227 (77)	3728 (235)
P5	2580 (163)	10319 (651)	1287 (81)	5045 (318)	858 (54)	3409 (215)
P7	3027 (191)	12107 (764)	1510 (95)	5800 (366)	1009 (64)	3969 (250)
P8	3625 (229)	14500 (915)	1812 (114)	6745 (426)	1208 (76)	4682 (295)
QB	2815 (178)	11260 (710)	1407 (89)	4029 (254)	938 (59)	2693 (170)
QD	3199 (202)	12794 (807)	1598 (101)	4526 (286)	1065 (67)	3042 (192)
QF	3680 (232)	14722 (929)	1839 (116)	5268 (332)	1227 (77)	3479 (220)
QH	1902 (120)	7608 (480)	951 (60)	2799 (177)	-	-
Q5	8283 (523)	33132 (2090)	4138 (261)	11049 (697)	2761 (174)	8597 (542)
Q7	2580 (163)	10319 (651)	1287 (81)	4734 (299)	858 (54)	3187 (201)
Q8	3027 (191)	12107 (764)	1510 (95)	5456 (344)	1009 (64)	3716 (234)
Q9	4344 (274)	17375 (1096)	2169 (137)	7344 (463)	-	-

Application Data (Cont'd)

Condenser Water – The chiller is engineered for maximum efficiency at both design and part load operation by taking advantage of the colder cooling tower water temperatures which naturally occur during the winter months. Appreciable power savings are realized from these reduced heads.

The minimum entering condenser water temperature for other full and part load conditions is provided by the following equation:

$$\text{Min. ECWT} = \text{LCHWT} - \text{C RANGE} + 5^{\circ}\text{F} + 12 \left(\frac{\% \text{Load}}{100} \right)$$

or

$$\text{Min. ECWT} = \text{LCHWT} - \text{C RANGE} + 2.8^{\circ}\text{C} + 6.6 \left(\frac{\% \text{Load}}{100} \right)$$

where:

ECWT = entering condensing water temperature

LCHWT = leaving chilled water temperature

C RANGE = condensing water temperature range

at the given load condition.

At initial startup, entering condensing water temperature may be as much as 25°F (13.9°C) colder than the standby chilled water temperature.

BRINE APPLICATIONS

Various types of brine can be used in both the evaporator and condenser in lieu of water. The OptiView Control panel is programmed in the factory to allow extending the evaporator leaving brine temperature setpoint below 36°F (2.2°C). The low evaporator pressure cutout is factory programmed to the appropriate value depending on the percent (%) concentration and type of brine solution.

When the chiller is not running, brine should not be run through the evaporator. However, if there is brine running through the evaporator, there must be flow through the condenser to prevent tubes from freezing. In brine applications the condenser pump control will close when the condenser saturation temperature reaches 35°F (1.7°C) and the pump will shut off when the temperature increases to 40°F (4.4°C). This is applicable if tied to the condenser pump control.

MULTIPLE UNITS

Selection – Many applications require multiple units to meet the total capacity requirements as well as to provide flexibility and some degree of protection against equipment shutdown. There are several common unit arrangements for this type of application. The YK chiller has been designed to be readily adapted to the requirements of these various arrangements.

Application Data (Cont'd)

Parallel Arrangement (Refer to Fig. 3) – Chillers may be applied in multiples with chilled and condenser water circuits connected in parallel between the units. Fig. 1 represents a parallel arrangement with two chillers. Parallel chiller arrangements may consist of equally or unequally sized units. When multiple units are in operation, they will load and unload at equal percentages of design full load for the chiller.

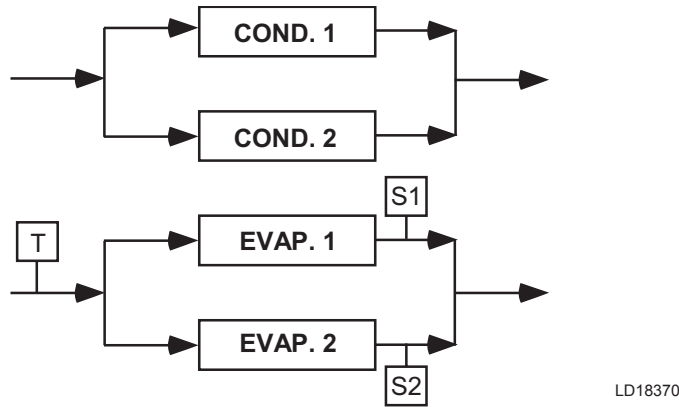

- S** – Temperature Sensor for Chiller Capacity Control
- T** – Thermostat for Chiller Capacity Control

FIGURE 3 - PARALLEL EVAPORATORS PARALLEL CONDENSERS

Depending on the number of units and operating characteristics of the units, loading and unloading schemes should be designed to optimize the overall efficiency of the chiller plant. It is recommended to use an evaporator bypass piping arrangement to bypass fluid around evaporator of any unit which has cycled off at reduced load conditions. It is also recommended to alternate the chiller cycling order to equalize chiller starts and run hours.

Series Arrangement (Refer to Fig. 4) – Chillers may be applied in pairs with chilled water circuits connected in series and condenser water circuits connected in parallel. All of the chilled water flows through both evaporators with each unit handling approximately one half of the total load. When the load decreases to a customer selected load value, one of the units will be shut down by a sequence control. Since all water is flowing through the operating unit, that unit will cool the water to the desired temperature.

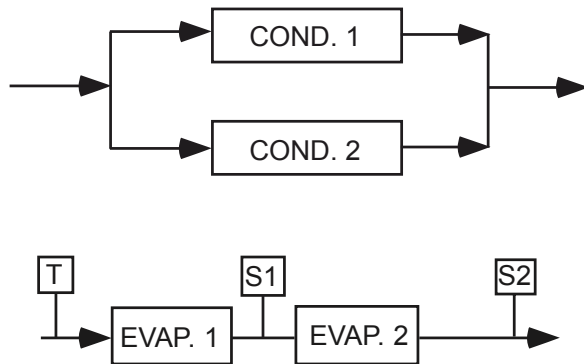

FIGURE 4 - SERIES EVAPORATORS PARALLEL CONDENSERS

LD18371

Series Counter Flow Arrangement (Refer to Fig. 5) - Chillers may be applied in pairs with chilled water circuits connected in series and with the condenser water in series counter flow. All of the chilled water flows through both evaporators. All of the condenser water

Application Data (Cont'd)

flows through both condensers. The water ranges are split, which allows a lower temperature difference or "head" on each chiller, than multiple units in parallel. For equal chillers, the machine at higher temperature level will typically provide slightly more than half the capacity. The compressor motors and gear codes on the two chillers are often matched, such that the high temperature machine can operate at the low temperature conditions when one unit is cycled off at part loads (as compared to series-parallel chillers which are typically not identical).

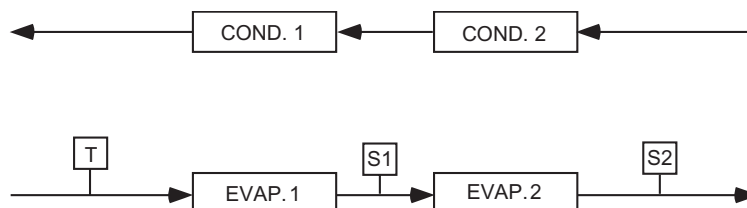

S – Temperature Sensor for Chiller Capacity Control

T – Thermostat for Chiller Capacity Control

Id18372

FIGURE 5 - SERIES EVAPORATORS SERIES-COUNTER FLOW CONDENSERS

Series counter flow application can provide a significant building energy savings for large capacity plants which have chilled and condenser water temperature ranges greater than typical AHRI.

HEAT RECOVERY

Heat recovery may be used in buildings, where there is a need for heating and cooling loads concurrently. By utilizing some or all of the heat rejection of a normal vapor-compression cycle cooling system, overall operating energy savings result. Heat recovery uses available heat as a by-product of the cooling function, which differs from heat pumps where the heating can be considered the primary process. Also, the heat recovery usage is often a winter seasonal duty, where the chiller may be expected to operate in summer using heat rejection to a conventional cooling tower. As heating loops and cooling tower water circuits are separate in the majority of buildings, this dictates the need for two water circuits in the condenser of a heat recovery chiller.

Very simply, heat recovery allows you to utilize the heat, [which would otherwise be "wasted" (to the cooling tower)], to serve a useful purpose. This heat of rejection can be used to:

- Pre-heat domestic hot water needs like in hotels or hospitals for use in:
- Laundry, showers, swimming pools, cooking/dishwashing, hot tub.
- Comfort heating (perimeter heating).
- Reheating of air.
- Preheating of boiler makeup water or process hot water.

The main difference between a cooling only chiller and a heat recovery chiller is in the heat recovery chiller's added ability to reject the "free condenser heat" to the cooling tower

Application Data (Cont'd)

and/or the heating system. Since heat is being removed from the area to be cooled, the cooling load supports the heating load. There must be a simultaneous cooling and heating load in the building.

When using a Solid-State Starter or Variable Speed Drive for a heat recovery application, the starters will be chilled water cooled.

Please refer to Form 160.75-AD2; YK Mod G Heat Recovery Application Data for additional information.

Heat Recovery Availability

Standard: Compressors Q4, Q7, H9, K2, K7

REFRIGERANT RELIEF PIPING

Each chiller is equipped with dual pressure relief valves on the condenser and two dual relief valves on the evaporator, or two single relief valves on the evaporator if the optional refrigerant isolation valves are ordered. The dual relief valves on the condenser are redundant and allow changing of either valve while the unit is fully charged. The purpose of the relief valves is to quickly relieve excess pressure of the refrigerant charge to the atmosphere, as a safety precaution in the event of an emergency such as fire. They are set to relieve at an internal pressure as noted on the pressure vessel data plate, and are provided in accordance with ASHRAE 15 safety code and ASME or applicable pressure vessel code.

Sized to the requirements of applicable codes, a vent line must run from the relief device to the outside of the building. This refrigerant relief piping must include a cleanable, vertical leg dirt trap to catch vent stack condensation. Vent piping must be arranged to avoid imposing a strain on the relief connection and should include one flexible connection.

SOUND AND VIBRATION CONSIDERATIONS

A YK chiller is not a source of objectionable sound and vibration in normal air conditioning applications. Neoprene isolation mounts are furnished as standard with each unit. Optional level adjusting spring isolator assemblies designed for 1" (25 mm) static deflection are available from Johnson Controls.

YK chiller sound pressure level ratings will be furnished on request.

Control of sound and vibration transmission must be taken into account in the equipment room construction as well as in the selection and installation of the equipment.

THERMAL INSULATION

No appreciable operating economy can be achieved by thermally insulating the chiller. However, the chiller's cold surfaces should be insulated with vapor barrier insulation sufficient to prevent condensation. A chiller can be factory-insulated with 3/4" (19 mm) or 1 1/2" (38 mm) thick insulation, as an option. This insulation will normally prevent condensation in environments with dry bulb temperatures of 50°F to 90°F (10°C to 32°C) and relative humidities up to 75% [3/4" (19 mm) thickness] or 90% [1 1/2" (38 mm) thickness]. The insulation is painted and the surface is flexible and reasonably resistant to wear. It is intended for a chiller installed indoors and, therefore, no protective covering of the insula-

Application Data (Cont'd)

tion is usually required. If insulation is applied to the waterboxes at the job site, it must be removable to permit access to the tubes for routine maintenance.

VENTILATION

The ASHRAE Standard 15 Safety Code for Mechanical Refrigeration requires that all machinery rooms be vented to the outdoors utilizing mechanical ventilation by one or more power driven fans. This standard, plus National Fire Protection Association Standard 90A, state, local and any other related codes should be reviewed for specific requirements. Since the YK chiller motor is air-cooled, ventilation should allow for the removal of heat from the motor.

In addition, the ASHRAE Standard 15 requires a refrigerant vapor detector to be employed for all refrigerants. It is to be located in an area where refrigerant from a leak would be likely to concentrate. An alarm is to be activated and the mechanical ventilation started at a value no greater than the TLV (Threshold Limit Value) of the refrigerant.

ELECTRICAL CONSIDERATIONS

Motor Voltage – Low voltage motors (200 to 600 volts) are furnished with six leads. Medium voltage (2300 to 13800 volts) motors have three leads. Motor circuit conductor size must be in accordance with the National Electrical Code (N.E.C.), or other applicable codes, for the motor full load amperes (FLA). Flexible conduit should be used for the last several feet to the chiller in order to provide vibration isolation. Table 6 lists the allowable variation in voltage supplied to the chiller motor. The unit name plate is stamped with the specific motor voltage, and frequency for the appropriate motor.

Starters – A separate starter is not required if the chiller is equipped with a Variable Speed Drive (VSD). The YK Chillers are also available with a factory mounted and wired York Solid-State Starter for low and medium voltage applications. Other types of remote mounted starters are available. Electromechanical starters must be furnished in accordance with YORK Standard Specifications (R-1132). This will ensure that starter components, controls, circuits, and terminal markings will be suitable for required overall system performance. Remote-mounted medium voltage York Solid-State Starters are also available.

Controls – A 115 volt, single-phase, 60 or 50 Hertz 2 KVA power supply must be furnished to the chiller from a separate, fused disconnect or from a control transformer included as an option with electro mechanical starters. No field control wiring is required when the low voltage YORK Variable Speed Drive or Solid-State Starter is supplied.

Oil Pump Power Supply – A separate 3 phase power supply with a fused disconnect for the factory-mounted oil pump variable speed drive is required unless the low voltage VSD or SSS is supplied. Power can also be supplied through an electro mechanical starter, remote mounted Medium Voltage Solid-State Starter (MVSSS) or Medium Voltage Variable Speed Drive (MVSVD).

Copper Conductors – Only copper conductors should be connected to compressor motors and starters. Aluminum conductors have proven to be unsatisfactory when connected to copper lugs. Aluminum oxide and the difference in thermal conductivity between copper and aluminum cannot guarantee the required tight connection over a long period of time.

Displacement Power-factor Correction Capacitors – When the chiller is equipped with a VSD, automatic displacement power factor correction to a minimum of 0.95 is provided at all operating conditions, so additional capacitors are not required. For other start-

Application Data (Cont'd)

ing methods, capacitors can be applied to a chiller for the purpose of displacement power factor correction. For remote-mounted electro-mechanical starters, the capacitors should be located on the load side of the starter. For YORK Solid-State Starters the capacitors must be located on the line side of the starter. The capacitors must be sized and installed to meet the National Electrical Code and be verified by Johnson Controls.

Ampacity on Load Side of Starter – Electrical power wire size to the chiller is based on the minimum unit ampacity. For Solid-State Starters or Variable Speed Drive, this wiring is done at the factory. For remote starters, the National Electrical Code defines the calculation of ampacity, as summarized below. More specific information on actual amperage ratings will be supplied with the submittal drawings:

- Six lead type of starting (Star Delta) Minimum circuit ampacity per conductor (1 of 6):

$$\text{Ampacity} = .721 \times \text{compressor motor amps.}$$

- Three lead type of starting (Across the Line, Autotransformer and Primary Reactor) Minimum circuit ampacity per conductor (1 of 3): Ampacity = 1.25 x compressor motor amps.

Ampacity on Line Side of Starter – The only additional load on the circuit for the chiller would be the control transformer and oil pump motor unless they are supplied by a separate source.

Minimum Circuit Ampacity = 125% of compressor motor amps + FLA of all other loads on the circuit.

Branch Circuit Overcurrent Protection – The branch circuit overcurrent protection device(s) should be a time delay type, with a minimum rating equal to the next standard fuse/breaker rating above the calculated value. It is calculated taking into account the compressor motor amps and may also include control transformer and oil pump motor. Refer to submittal drawings for the specific calculations for each application. See Table 14.

*For motor voltage above 4160V/60Hz and 3300V/50HZ contact the JCI Sales Office for a specific selection.

MOTOR ELECTRICAL DATA

The smallest motor available which equals or exceeds the Input power (kW) from the chiller rating program is selected from Tables 10. The full load amperes (FLA) listed in the tables is maximum values and corresponds to the maximum motor kW listed. When the input power (kW) is less than maximum motor kW, the FLA should be reduced per the following equation:

$$\text{FLA} = \frac{\text{Motor kW} \times \text{MAXIMUM Motor FLA}}{\text{MAXIMUM Motor kW}}$$

Application Data (Cont'd)

The benefit from the FLA correction is the possible use of smaller power wiring and/or starter size. The locked rotor amperes (LRA) are read directly from Table 10 for specific Motor Code and voltage.

This is because the LRA is dependent only on motor size and voltage and is independent of input power (kW). Inrush amperes (IRA) depend on LRA and the type of starter applied. The inrush can be calculated using a percentage of LRA shown in Tables 13 to 17.

TABLE 9 - MOTOR VOLTAGE VARIATIONS

FREQ.	RATED VOLTAGE	NAMEPLATE VOLTAGE*	OPERATING VOLTAGE	
			MIN.	MAXIMUM
60 HZ	200	200/208	180	220
	230	220/240	208	254
	380	380	342	415
	416	416	375	457
	460	440/460/480	414	508
	575	575/600	520	635
	2300	2300	2070	2530
	3300	3300	2970	3630
	4000	4000/4160	3600	4576
50 HZ	346	346	311	381
	380	380/400	342	423
	415	415	374	440
	3300	3300	2970	3630

Application Data (Cont'd)

TABLE 10 - 60 HZ ELECTRICAL DATA

MOTOR CODE	CF	CG	CH	CJ	CK	CL	CM	CN	CP	CR	CS	CT	CU	CV	CW	
SHAFT HP (MAX)	154	177	201	237	270	302	327	351	385	424	468	503	554	608	655	
INPUT KW (MAX)	123	140	161	190	214	240	257	276	302	333	367	395	435	477	514	
F.L. EFF. - % ¹	93.6	94.5	93.3	93	94	94	95	95	95	95	95	95	95	95	95	
F.L. POWER FACTOR ¹	0.86	0.86	0.86	0.86	0.86	0.86	0.86	0.86	0.86	0.87	0.87	0.87	0.87	0.87	0.87	
VOLTS	AMPERES (MAXIMUM)															
200	FLA	405	465	527	618	707	787	831	921	1014	1085	1208	-	-	-	-
	LRA	2598	3111	3111	3810	4550	4900	5470	5780	5780	7350	7794	-	-	-	-
208	FLA	389	447	507	594	680	757	799	886	975	1043	1162	-	-	-	-
	LRA	2702	3235	3235	3962	4732	5096	5689	6011	6011	7644	8106	-	-	-	-
230	FLA	352	404	464	540	610	685	749	804	882	944	1050	1130	-	-	-
	LRA	2598	2598	2865	3460	3788	4260	4755	5162	5780	5780	6900	7400	-	-	-
240	FLA	337	387	445	518	585	656	718	771	845	905	1006	1083	-	-	-
	LRA	2711	2711	3120	3610	3953	4445	4962	5386	6031	6031	7200	7722	-	-	-
380	FLA	217	249	285	336	378	421	453	487	534	571	636	684	756	817	879
	LRA	1385	1385	1730	2153	2500	2577	2955	3254	3637	3810	4179	4480	4671	5326	5780
416	FLA	199	228	260	307	346	385	412	445	488	522	581	625	691	747	810
	LRA	1385	1385	1638	1967	2190	2356	2700	2976	3536	3637	3810	3810	4270	4869	5640
440	FLA	184	211	238	281	319	358	392	397	461	493	549	591	646	706	759
	LRA	1177	1301	1320	1655	1865	2037	2485	2485	2976	2976	3300	3644	3644	4209	4783
460	FLA	176	202	228	269	305	342	375	380	441	472	525	565	618	675	726
	LRA	1230	1360	1380	1730	1950	2130	2598	2598	3111	3111	3450	3500	3810	4400	4880
480	FLA	169	194	219	258	292	328	359	364	423	452	503	541	592	647	696
	LRA	1283	1419	1440	1805	2035	2223	2711	2711	3246	3246	3600	3976	3976	4591	5217
575	FLA	141	162	185	216	250	274	300	318	353	377	420	452	500	540	581
	LRA	909	909	1100	1384	1556	1700	1900	2066	2078	2413	2760	2960	3089	3550	4039
600	FLA	135	155	177	207	240	263	288	305	338	361	403	433	479	518	557
	LRA	949	949	1148	1444	1624	1774	1983	2156	2168	2518	2880	3089	3223	3704	4215
2300	FLA	36	41.1	46	55	63	70	73.9	80	87	95	106	113	124	135	146
	LRA	240	267	298	340	397	435	480	520	543	590	669	719	791	867	935
3300	FLA	25.5	29	33	39	44	49	52	55.3	61	67	72.8	79	86.1	94.4	102
	LRA	160	175	210	240	280	310	310	343	382	415	466	501	551	576	652
4000	FLA	21	24	26.7	32	36	40	42.5	46	50.1	55	60.1	65.2	71	77.9	84
	LRA	135	154	166	195	230	240	270	283	315	340	384	413	455	499	538
4160	FLA	20.2	23	25.7	30.8	34.6	38.5	40.9	44.2	48.2	52.9	57.8	62.7	68.3	74.9	80.8
	LRA	140	160	173	203	239	250	270	294	328	328	399	430	473	519	560

NOTES:

- High voltage and special motor designs may not meet efficiency, power factor or amperes values shown for standard motors.
- Min. reduced voltage tap 80%.

Application Data (Cont'd)

TABLE 10 - 60 HZ ELECTRICAL DATA (CONT'D)

MOTOR CODE	CX	CY	CZ	CA	CB	DA	DB	DC	DD	DE	DF	DH	DJ	DK	DL
SHAFT HP (MAX)	690	740	790	845	900	1000	1100	1200	1300	1400	1500	1750	2000	2250	2500
INPUT KW (MAX)	542	578	618	660	703	781	859	937	1015	1093	1171	1359	1554	1748	1942
F.L. EFF. - % ¹	95	95.5	95.3	95.5	95.5	95.5	95.5	95.5	95.5	95.5	95.5	96	96	96	96
F.L. POWER FACTOR ₁	0.87	0.88	0.88	0.89	0.89	0.87	0.87	0.87	0.88	0.88	0.88	0.87	0.89	0.89	0.89
VOLTS															
AMPERES (MAXIMUM)															
200	FLA	-	-	-	-	-	-	-	-	-	-	-	-	-	-
	LRA	-	-	-	-	-	-	-	-	-	-	-	-	-	-
208	FLA	-	-	-	-	-	-	-	-	-	-	-	-	-	-
	LRA	-	-	-	-	-	-	-	-	-	-	-	-	-	-
230	FLA	-	-	-	-	-	-	-	-	-	-	-	-	-	-
	LRA	-	-	-	-	-	-	-	-	-	-	-	-	-	-
240	FLA	-	-	-	-	-	-	-	-	-	-	-	-	-	-
	LRA	-	-	-	-	-	-	-	-	-	-	-	-	-	-
380	FLA	942	997	1065	1126	1200	1364	1500	1636	-	-	-	-	-	-
	LRA	5780	5780	6644	7610	7513	7794	8491	9431	-	-	-	-	-	-
416	FLA	860	911	973	1029	1096	1246	1370	1495	-	-	-	-	-	-
	LRA	5670	5694	6069	6900	6863	7120	7755	8618	-	-	-	-	-	-
440	FLA	813	861	920	973	1036	1178	1295	1413	-	-	-	-	-	-
	LRA	5357	4783	5249	5791	5529	6160	6709	7455	-	-	-	-	-	-
460	FLA	778	824	880	931	991	1127	1239	1352	-	-	-	-	-	-
	LRA	4960	5280	5330	6054	5780	6440	7014	7794	-	-	-	-	-	-
480	FLA	746	790	843	892	950	1080	1187	1296	-	-	-	-	-	-
	LRA	5843	5217	5727	6317	6031	6720	7319	8133	-	-	-	-	-	-
575	FLA	622	659	704	744	793	901	991	1081	-	-	-	-	-	-
	LRA	4100	4200	4200	5225	4963	5148	5610	6232	-	-	-	-	-	-
600	FLA	596	632	675	713	760	863	950	1036	-	-	-	-	-	-
	LRA	4633	4487	4383	5452	5179	5372	5854	6503	-	-	-	-	-	-
2300	FLA	154	165	176	186	198	225	248	267	290	312	334	383	438	493
	LRA	960	1008	1100	1172	1230	1350	1592	1592	1882	2031	2171	2390	2879	3199
3300	FLA	108	115	123	130	138	157	173	186	202	217	233	267	306	344
	LRA	682	719	744	819	858	942	1110	1110	1311	1416	1514	1661	2011	2388
4000	FLA	88.6	94.8	101	107	114	130	143	154	166	179	192	220	252	283
	LRA	540	554	631	674	713	780	923	923	1077	1177	1246	1428	1669	1842
4160	FLA	85.2	91.1	97.1	102	110	125	137	148	160	172	185	212	242	273
	LRA	562	576	656	701	742	811	960	960	1120	1224	1296	1485	1736	1968

NOTES:

- High voltage and special motor designs may not meet efficiency, power factor or amperes values shown for standard motors.
- Min. reduced voltage tap 80%.

Application Data (Cont'd)

TABLE 11 - 50 HZ ELECTRICAL DATA

MOTOR CODE	5CC	5CD	5CE	5CF	5CG	5CH	5CI	5CJ	5CK	5CL	5CM	5CN	5CO	5CP	5CQ	5CR	5CS	
SHAFT HP (MAX)	148	168	198	225	252	272	292	321	353	390	419	462	507	546	575	617	658	
INPUT KW (MAX)	119	135	158	179	201	215	231	254	279	309	332	363	398	429	451	484	516	
F.L. EFF. - % ¹	93	93	93.4	93.7	93.7	94.2	94.2	94.2	94.2	94.2	94.2	95	95	95	95	95	95	
F.L. POWER FACTOR ¹	0.86	0.86	0.86	0.86	0.86	0.86	0.86	0.86	0.87	0.87	0.87	0.87	0.87	0.87	0.87	0.87	0.88	
VOLTS	AMPERES (MAXIMUM)																	
346	FLA	230	261	306	347	389	418	448	493	536	592	636	696	763	822	866	929	979
	LRA	1385	1721	1790	2208	2467	2598	2840	3081	3350	3706	3810	4177	4830	4944	5373	5780	5780
380	FLA	210	238	278	316	354	380	408	449	488	539	579	633	695	748	788	846	892
	LRA	1385	1385	1640	1890	2144	2464	2590	2806	3050	3375	3700	3810	4400	4500	4892	5600	5491
400	FLA	200	226	264	300	336	361	388	427	464	512	550	601	660	711	749	804	847
	LRA	1458	1458	1726	1990	2257	2594	2726	2954	3211	3533	3895	4011	4632	4737	5149	5895	5780
415	FLA	192	218	255	290	324	348	374	411	447	494	530	580	636	685	722	774	817
	LRA	1283	1385	1490	1700	2031	2175	2366	2569	2794	3088	3402	3478	3810	4117	4480	5130	5108
3300	FLA	24.1	27.4	32.2	36.4	40.8	43.8	47	51.7	56.2	62.1	66.7	72.9	80	86.2	90.8	97.4	103
	LRA	159	162	209	236	241	274	294	318	317	388	423	455	499	516	572	614	644

NOTES:

- High voltage and special motor designs may not meet efficiency, power factor or amperes values shown for standard motors.
- Min. reduced voltage tap 80%.

TABLE 12 - 50 HZ ELECTRICAL DATA (CONT'D)

MOTOR CODE	5CT	5CU	5CV	5CW	5CX	5DA	5DB	5DC	5DD	5DE	5DF	5DG	5DH	5DJ ²	5DK	5DL
SHAFT HP (MAX)	704	750	800	850	900	1000	1100	1200	1300	1400	1500	1650	1750	2000	2250	2500
INPUT KW (MAX)	553	589	628	667	706	785	863	942	1015	1093	1171	1288	1359	1554	1748	1942
F.L. EFF. - % ¹	95	95	95	95	95	95	95	95	95.5	95.5	95.5	95.5	96	96	96	96
F.L. POWER FACTOR ¹	0.88	0.89	0.89	0.89	0.89	0.88	0.87	0.88	0.88	0.88	0.88	0.88	0.89	0.89	0.89	0.89
	AMPERES (MAXIMUM)															
346	FLA	1048	1104	1177	1251	1325	1488	1656	-	-	-	-	-	-	-	-
	LRA	6615	6931	7356	7794	8319	8559	9346	-	-	-	-	-	-	-	-
380	FLA	954	1005	1072	1139	1206	1355	1508	-	-	-	-	-	-	-	-
	LRA	5491	6313	6694	7113	7404	7794	8511	-	-	-	-	-	-	-	-
400	FLA	906	955	1018	1082	1146	1287	1433	-	-	-	-	-	-	-	-
	LRA	5780	6645	7046	7487	7794	8204	8959	-	-	-	-	-	-	-	-
415	FLA	874	920	982	1043	1104	1241	1381	-	-	-	-	-	-	-	-
	LRA	5512	5780	6131	6513	6938	7138	7794	-	-	-	-	-	-	-	-
3300	FLA	110	116	123	131	139	156	174	187	202	217	233	256	267	306	344
	LRA	693	725	744	819	875	871	1135	1135	1135	1415	1415	1415	1667	1836	2233

NOTES:

- High voltage and special motor designs may not meet efficiency, power factor or amperes values shown for standard motors.
- Min. reduced voltage tap 80%.

Application Data (Cont'd)

TABLE 13- 60 HZ ELECTRICAL DATA - PREMIUM EFFICIENCY

MOTOR CODE	EF	EG	EH	EJ	EK	EL	EM	EN	EP	ER	ES	ET	EU	EV	
SHAFT HP (MAX)	154	177	201	237	270	302	327	351	385	424	468	503	554	608	
INPUT KW (MAX)	122	139	158	185	211	236	256	274	300	330	364	392	431	473	
F.L. EFF. - %	94.5	95	95	95.4	95.4	95.4	95.4	95.4	95.8	95.8	95.8	95.8	95.8	95.8	
F.L. POWER FACTOR	0.88	0.88	0.88	0.88	0.88	0.88	0.88	0.88	0.88	0.88	0.88	0.88	0.88	0.88	
VOLTS	AMPERES (MAXIMUM)														
200	FLA	399	456	518	608	692	774	838	900	983	1083	1195	-	-	-
	LRA	2815	3128	3128	3979	4550	4900	5635	5865	6686	7350	7935	-	-	-
208	FLA	383	438	498	584	666	745	806	865	945	1041	1149	-	-	-
	LRA	2928	3235	3235	4138	4732	5096	5860	6100	6953	7644	8252	-	-	-
230	FLA	347	396	450	528	602	673	729	783	855	941	1039	1117	-	-
	LRA	2598	2720	2865	3460	3788	4260	4900	5162	5814	6200	6900	8513	-	-
240	FLA	332	380	431	506	577	645	699	750	819	902	996	1070	-	-
	LRA	2711	2838	2990	3610	3953	4445	5113	5386	6067	6470	7200	8883	-	-
380	FLA	210	240	272	320	364	408	441	474	517	570	629	676	745	817
	LRA	1482	1646	1730	2153	2500	2578	2966	3254	3637	3810	4179	4480	4671	5326
416	FLA	192	219	249	292	333	372	403	433	473	521	575	617	680	746
	LRA	1385	1504	1638	1967	2190	2356	2709	2976	3536	3637	3815	3826	4270	5418
440	FLA	181	207	235	276	315	352	381	409	447	492	543	584	643	706
	LRA	1177	1301	1320	1655	1865	2037	2485	2485	2976	2976	3300	3348	3644	4687
460	FLA	173	198	225	264	301	337	365	391	427	471	520	558	615	675
	LRA	1230	1360	1380	1730	1950	2130	2598	2598	3111	3111	3450	3500	3810	4900
480	FLA	166	190	216	253	288	323	349	375	410	451	498	535	589	647
	LRA	1283	1419	1440	1805	2035	2223	2711	2711	3246	3246	3600	3652	3976	5113
575	FLA	139	159	180	211	241	269	292	313	342	377	416	447	492	540
	LRA	979	1088	1100	1384	1556	1704	1960	2066	2326	2413	2760	2960	3089	3550
600	FLA	133	152	173	203	231	258	279	300	328	361	398	428	472	517
	LRA	1021	1135	1148	1444	1624	1778	2045	2156	2427	2518	2880	3089	3223	3704

TABLE 14 - 50 HZ ELECTRICAL DATA - PREMIUM EFFICIENCY

MOTOR CODE	5EC	5ED	5EE	5EF	5EG	5EH	5EI	5EJ	5EK	5EL	5EM	5EN	5EO	
SHAFT HP (MAX)	148	168	198	225	252	272	292	321	353	390	419	462	507	
INPUT KW (MAX)	117	133	156	177	198	214	229	252	277	305	328	361	396	
F.L. EFF. - %	94.3	94.5	94.7	94.9	95	95	95	95	95	95.4	95.4	95.4	95.4	
F.L. POWER FACTOR	0.88	0.88	0.88	0.88	0.88	0.88	0.88	0.88	0.88	0.88	0.88	0.88	0.88	
VOLTS	AMPERES (MAXIMUM)													
346	FLA	222	251	296	335	375	405	435	478	525	578	621	685	751
	LRA	1521	1721	1790	2208	2467	2706	2840	3081	3350	3706	3810	4177	4830
380	FLA	202	229	269	305	342	369	396	435	478	526	565	623	684
	LRA	1385	1385	1640	1890	2144	2464	2590	2806	3050	3375	3700	3810	4690
400	FLA	192	217	256	290	324	350	376	413	454	500	537	592	650
	LRA	1458	1458	1726	1989	2257	2594	2726	2954	3211	3553	3895	4011	4937
415	FLA	185	210	246	280	313	338	362	398	438	482	518	571	627
	LRA	1283	1385	1502	1700	2031	2175	2366	2569	2794	3088	3402	3478	4027

Application Data (Cont'd)

TABLE 15 - MOTOR STARTERS

TYPE STARTER	SOLID-STATE STARTER	STAR DELTA	AUTO TRANSFORMER			ACROSS-THE-LINE	PRIMARY REACTOR	
			VOLTAGE	LOW/MEDIUM	LOW		LOW	LOW/MEDIUM
60 HZ	200-4160	200-600	200-600	200-4160	200-4160	200-4160	2300-4160	2300-4160
50 HZ	380-3300	346-415	346-415	346-3300	346-3300	346-3300	2300-3300	2300-3300
TRANSITION % TAP INRUSH AS A % OF LRA	—	CLOSED	CLOSED	CLOSED	CLOSED	—	CLOSED	CLOSED
	—	—	57.7	65	80	—	65	80
	45	33	33	42.3	64	100	65	80

NOTES:

1. For motor starters above 4160V/60Hz and 3300/50Hz contact the Johnson Controls Sales Office for a specific selection.
2. Minimum tap for 5DJ motor is 80%.

TABLE 16 - LOW VOLTAGE VARIABLE SPEED MODELS

FRAME LV-VSD	MAXIMUM LRA	MAXIMUM MOTOR HP	MINIMUM FLA	MAXIMUM FLA	RATED VOLTAGE	ACTUAL VOLTAGE	PHASE	HZ
I	2500	270	80	364	380	380	3	60
II	3637	385	120	517				
III	5326	608	200	817				
IV	7610	845	300	1126				
I	2598	351	80	380	460	440/ 460/ 480		
II	3652	503	120	565				
III	5777	790	200	880				
IV	7014	1048	300	1180				
I	2413	424	80	377	575	575/600		
II	3550	608	120	540				
I	2727	292	80	380	380	380/400	3	50
II	2895	419	120	565				
III	5780	658	200	880				
IV	8205	917	300	1180				
I	2366	292	80	362	415	415		
II	3402	419	120	518				
III	5512	704	200	876				
IV	6938	900	300	1108				

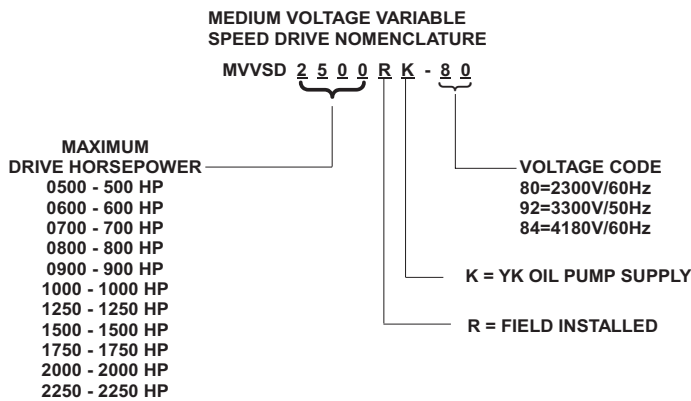

Application Data (Cont'd)

TABLE 17 - MEDIUM VOLTAGE VARIABLE SPEEDDRIVE MODELS

MV-VSD	MAXIMUM MOTOR HP	MAXIMUM FLA	VOLTAGE	PHASE	HZ
MVVSD0500RK-80	500	107	2300	3	60
MVVSD0600RK-80	600	129			
MVVSD0700RK-80	700	157			
MVVSD0800RK-80	800	172			
MVVSD0900RK-80	900	202			
MVVSD1000RK-80	1000	224			
MVVSD1250RK-80	1250	280			
MVVSD1500RK-80	1500	336			
MVVSD1750RK-80	1750	392			
MVVSD2000RK-80	2000	438			
MVVSD2250RK-80	2250	494			
MVVSD2500RK-80	2500	561			
MVVSD0500RK-94	500	78			
MVVSD0600RK-94	600	93			
MVVSD0700RK-94	700	110			
MVVSD0800RK-94	800	124			
MVVSD0900RK-94	900	141			
MVVSD1000RK-94	1000	156			
MVVSD1250RK-94	1250	195			
MVVSD1500RK-94	1500	235			
MVVSD1750RK-94	1750	274			
MVVSD2000RK-94	2000	312			
MVVSD2250RK-94	2250	345			
MVVSD2500RK-94	2500	391			
MVVSD0500RK-92S	500	62	4160	3	60
MVVSD0600RK-92S	600	74			
MVVSD0700RK-92S	700	87			
MVVSD0800RK-92S	800	99			
MVVSD0900RK-92S	900	112			
MVVSD1000RK-92S	1000	125			
MVVSD1250RK-92S	1250	155			
MVVSD1500RK-92S	1500	186			
MVVSD1750RK-92S	1750	217			
MVVSD2000RK-92S	2000	248			
MVVSD2250RK-92S	2250	274			
MVVSD2500RK-92S	2500	310			
MVVSD0500RK-92	500	78			
MVVSD0600RK-92	600	93			
MVVSD0700RK-92	700	110			
MVVSD0800RK-92	800	124			
MVVSD0900RK-92	900	141			
MVVSD1000RK-92	1000	156			
MVVSD1250RK-92	1250	195			
MVVSD1500RK-92	1500	235			
MVVSD1750RK-92	1750	274			
MVVSD2000RK-92	2000	312			
MVVSD2250RK-92	2250	345			
MVVSD2500RK-92	2500	391			

Application Data (Cont'd)

TABLE 18 - LOW VOLTAGE SOLID-STATE STARTER MODELS

MODEL SSS-	MAXIMUM LRA	MINIMUM FLA	MAXIMUM FLA	RATED VOLTAGE	ACTUAL VOLTAGE	PHASE	HZ
7L-46B	1556	35	260	460	440/460/480	3	60
7L-40B	1556	35	260	380	380	3	60
7L-50B	1556	35	260	400	380/440/415	3	50
7L-58B	1556	35	260	575	575/600	3	60
14L-17B	3111	65	510	200	200/208	3	60
14L-28B	3111	65	510	230	230/240	3	60
14L-40B	3111	65	510	380	380	3	60
14L-46B	3111	65	510	460	440/460/480	3	60
14L-50B	3111	65	510	400	380/400/415	3	50
14L-58B	3111	65	510	575	575/600	3	60
26L-17B	5780	125	850	200	200/208	3	60
26L-28B	5780	125	850	230	230/240	3	60
26L-40B	5780	125	850	380	380	3	60
26L-46B	5780	125	850	460	440/460/480	3	60
26L-50B	5780	125	850	400	380/400/415	3	50
26L-58B	5780	125	850	575	575/600	3	60
33L-17B	7333	215	1050	200	200/240	3	60
33L-40B	7333	215	1050	380	380	3	60
33L-46B	7333	215	1050	230	230/240	3	60
33L-50B	7333	215	1050	400	380/400/415	3	50
33L-58B	7333	215	1050	460	440/460/480	3	60

TABLE 19 - MEDIUM VOLTAGE UNIT MOUNTED SOLID-STATE STARTER MODELS

MODEL UNIT MOUNTED MV-SSS	MAXIMUM FLA	MAXIMUM LRA	RATED VOLTAGE & FREQUENCY		
UMVSSS0853K105-V V	105	1896	2300/60HZ	3300/50HZ	4160/60HZ
UMVSSS0853K190-V V	190	1896			
UMVSSS0853K280-V V	280	1896			
UMVSSS0853K389-V V	389	1896			
UMVSSS1708K389-V V	389	3796			

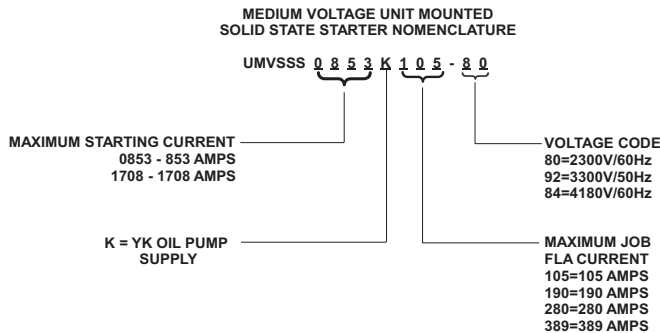

Application Data (Cont'd)

TABLE 20 - MEDIUM VOLTAGE FLOOR MOUNTED SOLID-STATE STARTER MODELS

MODEL FLOOR MOUNTED MV-SSS	MAXIMUM FLA	MAXIMUM LRA
36" CABINET UNIT MODEL REFERENCE CHART		
MVSS0853R_042-V	42	1896
MVSS0853R_050-V	50	1896
MVSS0853R_065-V	65	1896
MVSS0853R_095-V	95	1896
MVSS0853R_105-V	105	1896
MVSS0853R_140-V	140	1896
MVSS0853R_190-V	190	1896
MVSS0853R_280-V	280	1896
MVSS0853R_310-V	310	1896
MVSS0853R_360-V	360	1896
MVSS1708R_360-V	360	3796
72" CABINET UNIT MODEL REFERENCE CHART		
MVSS1708R_550-V	TABLE 9 - 550	TABLE 10 - 3796

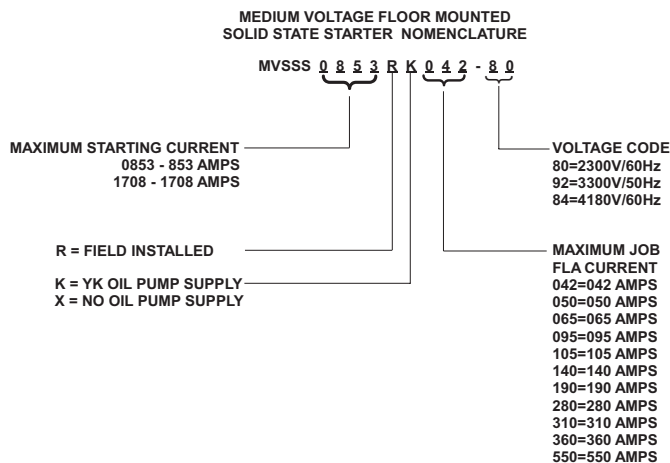

Application Data (Cont'd)

TABLE 21 - AVAILABLE COMPRESSOR/SHELL/MOTOR COMBINATIONS

YK MOD G COMBINATIONS				
COMPRESSOR CODES	EVAPORATOR CODES	CONDENSER CODES	MOTOR CODES	
			60 HZ	50 HZ
Q3	AP to AS	AP to AS	CF-CT ef-et	5CC-5CO 5ec-5eO
Q3, Q4	CP to CS	CP to CS		
	DP to DS	DP to DS		
Q4	EP to ET	EP to ET	CH-CT eh-et	5CE-5CO 5ee-5eo
Q5	CP to CS	CP to CS		
	DP to DS	DP to DS		
Q5, Q6, Q7	EP to ET	EP to ET	CU-CY eu-ev	5CP-5CU
	FQ to FT	FQ to FT		
P7	EP to ET	EP to ET		
	FQ to FT	FQ to FT		
P8	GQ to GS	EV to EX	CN-CA en-ev	5CK-5CW 5ek-5eo
P8, P9	HQ to HS	FV to FX		
	JP to JS	JP to JS		
	LQ to LS	LQ to LS		
H9	KP to KS, K2 to K4	KP to KS, K2 to K4	CS-DC es-ev	5CN-5DC 5en-5eo
	MQ to MS, M2 to M4	MP to MS, M2 to M4		
K1	KT to KX, K5 to K7	KP to KS, K2 to K4	DA-DJ	5DA-5DH
K1, K2	MQ to MS, M2 to M4	MP to MS, M2 to M4		
	NQ to NS, N2 to N4	NP to NS, N2 to N4		
	PQ to PS, P2 to P4	PQ to PS, P2 to P4		
	QQ to QS, Q2 to Q4	QQ to QS, Q2 to Q4		
K3	NQ to NS, N2 to N4	NP to NS, N2 to N4	DD-DL	5DD-5DL
	QQ to QV, Q2 to Q4	QQ to QS, Q2 to Q4		
	RQ, RS, RV, R3, R5, R7	RQ to RS, R2 to R4		
K4	RP, RR, RT, R2, R4, R6	RQ to RS, R2 to R4	DA-DJ	5DA-5DJ
	SQ, SS, SV, S3, S5, S7	SQ to SS, S2 to S4		
		VP to VS, V2 to V5		
	XQ to XS, X2 to X4	TP to TS, T2 to T5		
XQ to XS, X2 to X4				
K7	WP-WT, W1, W2, W4, W6	WQ to WS, W1 to W4	DD-DL	5DD-5DL
	ZQ to ZS, Z1 to Z4	ZQ to ZS, Z1 to Z4		

Application Data (Cont'd)

TABLE 21 - AVAILABLE COMPRESSOR/SHELL/MOTOR COMBINATIONS (CONT'D)

YK MOD G HEAT RECOVERY COMBINATIONS				
COMPRESSOR CODES	EVAPORATOR CODES	CONDENSER CODES	MOTOR CODES	
			60 HZ	50 HZ
Q4	CP TO CS	BW, BX	CF-CT	5CC-5CO
Q7	EP TO ET	IW, IX	EF-ET	5EC-5EO
H9	KP TO KS, K2 TO K4	OW, OX, O8, O9	CN-CA EN-EV	5CK-5CW 5EK-5EO
K2	MQ TO MS, M2 TO M4	UW, UX, U8, U9	CS-DC ES-EV	5CN-5DC 5EN-5EO
K7	ZQ TO ZS, Z1 TO Z4	YW, YX, Y8, Y9	DD-DL	5DD-5DL
YK MOD G HYBRID FALLING FILM COMBINATIONS				
COMPRESSOR CODES	HYBRID FALLING FILM EVAPORATOR CODES	CONDENSER CODES	MOTOR CODES	
			60 HZ	50 HZ
Q3	AC, AD, A3, A4	AP to AS	CF-CT EF-ET	5CC-5CO 5EC-5EO
	CC to CE, C3 to C5	CP to CS		
Q4	CC to CE, C3 to C5	CP to CS	CH-CT EH-ET	5CE-5CO 5EE-5EO
	DC to DE, D3 to D5	DP to DS		
Q5	CC to CE, C3 to C5	CP to CS	CU-CY EU-EV	5CP-5CU
	DC to DE, D3 to D5	DP to DS		
Q5, Q6, Q7	EC to EE, E3 to E5	EP to ET	CH-CZ EH-EV	5CE-5CU 5EE-5EO
	FC to FE, F3 to F5	FQ to FT		
P7	EC to EE, E3 to E5	EP to ET	CH-CZ EH-EV	5CE-5CU 5EE-5EO
	FC to FE, F3 to F5	FQ to FT		
P8, P9	GC to GE, G3 to G5	EV to EX, E3 to E4	CN-CA EN-EV	5CK-5CW 5EK-5EO
	HC to HE, H3 to H5	FV to FX, F3 to F4		
H9	KC, KD, K8, K9, K0	KP, KQ, KR, KS, K2, K3, K4	CN-CA EN-EV	5CK-5CW 5EK-5EO
	IB, ID, IF, IH, I2, I4, I6, I8	KP, KQ, KR, KS, K2, K3, K4		
	MB, MD, MF, M5, M7, M8	MP, MQ, MR, MS, M2, M3, M4		
K1	IB, ID, IF, IH, I2, I4, I6, I8	KP, KQ, KR, KS, K2, K3, K4	CS-DC ES-EV	5CN-5DC 5EN-5EO
K1, K2	MB, MD, MF, M5, M7, M8, M9	MP, MQ, MR, MS, M2, M3, M4		
	NB, ND, NF, N5, N7, N8, N9	NP, NQ, NR, NS, N2, N3, N4		
	PB, PD, PF, P5, P7, P8	PQ, PR, PS, P2, P3, P4		
K3	QB, QD, QF, Q5, Q7, Q8	QQ, QR, QS, Q2, Q3, Q4	DA-DJ	5DA-5DH
	NB, ND, NF, N5, N7, N8, N9	NP, NQ, NR, NS, N2, N3, N4		
	QD, QF, QH, Q5, Q7, Q8, Q9	QQ, QR, QS, Q2, Q3, Q4		

Dimensions

H, P, & Q COMPRESSOR UNITS

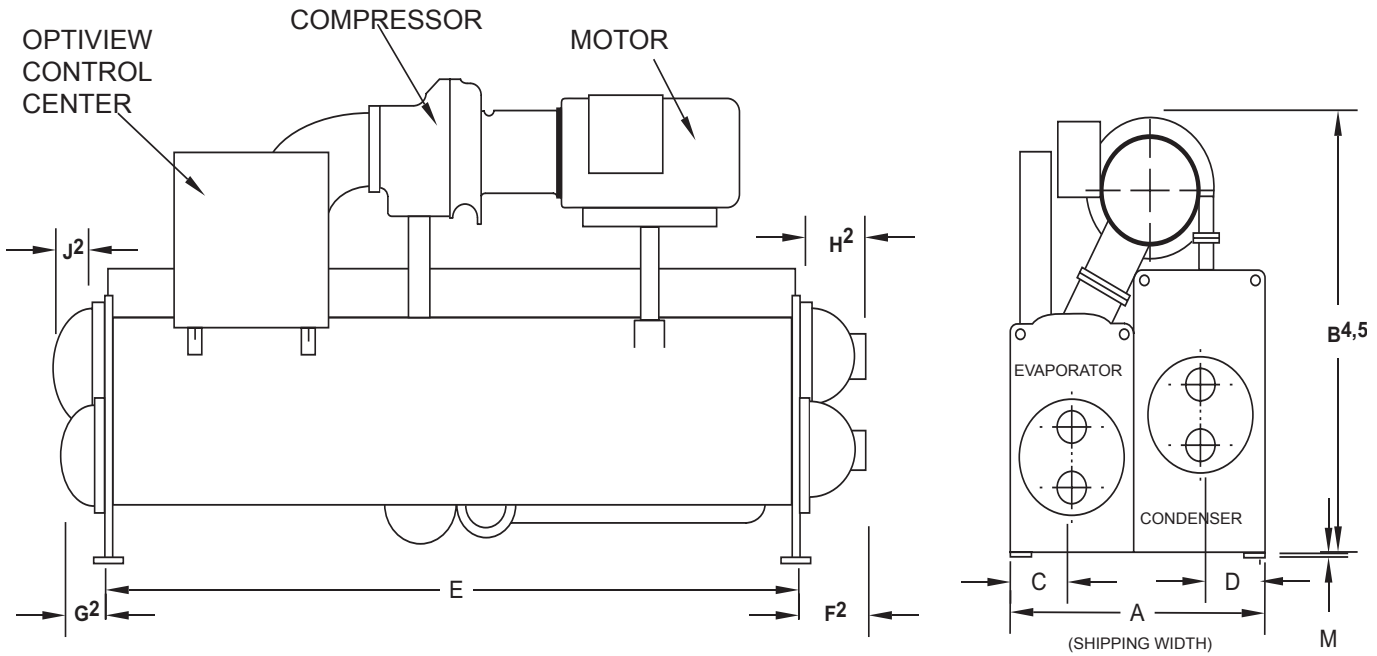

LD07134

ADDITIONAL OPERATING HEIGHT CLEARANCE TO FLOOR	
TYPE OF CHILLER MOUNTING	M
NEOPRENE PAD ISOLATORS	1-3/4" (45)
SPRING ISOLATORS 1" DEFLECTION	1" (25)
DIRECT MOUNT	3/4" (19)

P7, Q7 COMPRESSOR EVAPORATOR-CONDENSER SHELL CODES			
	E-E	E-I	F-F
A	6'-2" (1880)	7'-1 3/4" (2178)	6'-2" (1880)
B	8'-0 5/8" (2454)	8'-8" (2642)	8'-0 5/8" (2454)
C	1'-7 1/2" (495)	1'-7 1/2" (495)	1'-7 1/2" (495)
D	1'-5 1/2" (445)	1'-11 3/8" (594)	1'-5 1/2" (445)
E	12'-0" (3658)	12'-0" (3658)	16'-0" (4877)

P8 COMPRESSOR EVAPORATOR-CONDENSER SHELL CODES				
	G-E	H-F	J-J	L-L
A	6'-11" (2108)	6'-11" (2108)	7'-6 1/2" (2299)	7'-6 1/2" (2299)
B	10'-6" (3200)	10'-6" (3200)	10'-11" (3327)	10'-11" (3327)
C	2'-0" (610)	2'-0" (610)	2'-1 1/4" (641)	2'-1 1/4" (641)
D	1'-5 1/2" (445)	1'-5 1/2" (445)	1'-8" (508)	1'-8" (508)
E	12'-0" (3658)	16'-0" (4877)	12'-0" (3658)	16'-0" (4877)

P9 COMPRESSOR EVAPORATOR-CONDENSER SHELL CODES			
	H-F	J-J	L-L
A	6'-11" (2108)	7'-6 1/2" (2299)	7'-6 1/2" (2299)
B	10'-3" (3124)	10'-8 1/2" (3264)	10'-8 1/2" (3264)
C	2'-0" (610)	2'-1 1/4" (641)	2'-1 1/4" (641)
D	1'-5 1/2" (445)	1'-8" (508)	1'-8" (508)
E	16'-0" (4877)	12'-0" (3658)	16'-0" (4877)

Dimensions (Cont'd)

H, P, & Q COMPRESSOR UNITS

Q3 COMPRESSOR EVAPORATOR-CONDENSER SHELL CODES			
	A-A	C-C	D-D
A	5'-1" (1549)	5'-6" (1676)	5'-6" (1676)
B	7'-0" (2134)	7'-3 3/4" (2229)	7'-3 3/4" (2229)
C	1'-3 1/2" (394)	1'-5 1/2" (445)	1'-5 1/2" (445)
D	1'-3" (381)	1'-3 1/2" (394)	1'-3 1/2" (394)
E	12'-0" (3658)	12'-0" (3658)	16'-0" (4877)

Q4 COMPRESSOR EVAPORATOR-CONDENSER SHELL CODE				
	C-B	C-C	D-D	E-E
A	6'-4 3/4" (1949)	5'-6" (1676)	5'-6" (1676)	7'-0" (2134)
B	7'-11 3/8" (2423)	7'-2 1/2" (2197)	7'-2 1/2" (2197)	7'-8 1/2" (2350)
C	1'-5 1/2" (445)	1'-5 1/2" (445)	1'-5 1/2" (445)	1'-7 1/2" (495)
D	1'-8 7/8" (530)	1'-3 1/2" (394)	1'-3 1/2" (394)	1'-5 1/2" (445)
E	12'-0" (3658)	12'-0" (3658)	16'-0" (4877)	12'-0" (3658)

Q5 COMPRESSOR EVAPORATOR-CONDENSER SHELL CODES				
	C-C	D-D	E-E	F-F
A	5'-6" (1676)	5'-6" (1676)	7'-0" (2134)	7'-0" (2134)
B	7'-10 5/8" (2403)	7'-10 5/8" (2403)	8'-3" (2578)	8'-3" (2578)
C	1'-5 1/2" (445)	1'-5 1/2" (445)	1'-7 1/2" (495)	1'-7 1/2" (495)
D	1'-3 1/2" (394)	1'-3 1/2" (394)	1'-5 1/2" (445)	1'-5 1/2" (445)
E	12'-0" (3658)	16'-0" (4877)	12'-0" (3658)	16'-0" (4877)

Q6 COMPRESSOR EVAPORATOR-CONDENSER SHELL CODES		
	E-E	F-F
A	7'-0" (2134)	7'-0" (2134)
B	8'-3" (2515)	8'-3" (2515)
C	1'-7 1/2" (495)	1'-7 1/2" (495)
D	1'-5 1/2" (445)	1'-5 1/2" (445)

H9 COMPRESSORS EVAP.-COND. SHELL CODES			
DIM	I-K & K-K	K-O	M-M
A	7'-6 1/2" (2299)	8'-9 1/4" (2673)	8'-7" (2616)
B	10'-4" (3150)	10'-7 5/8" (3242)	10'-10 1/2" (3315)
C	2'-1 1/4" (641)	2'-1 1/4" (641)	2'-4 1/2" (724)
D	1'-8" (508)	2'-3 3/8" (695)	1'-11" (584)
E	14'-0" (4267)	14'-0" (4267)	14'-0" (4267)

NOTES:

- All dimensions are ft-inches (mm).
- All dimensions are approximate. Certified dimensions are available on request.
- For all waterboxes (compact boxes shown above), determine overall unit length by adding waterbox depth to tube sheet length.
- Water nozzles can be located on either end of unit. Add 1/2" (12mm) to nozzle length for flanges connections.
- To determine overall height, add dimension "M" for the appropriate isolator type.
- Use of motors with motor hoods may increase overall unit dimensions.

Dimensions (Cont'd)

K COMPRESSOR UNITS

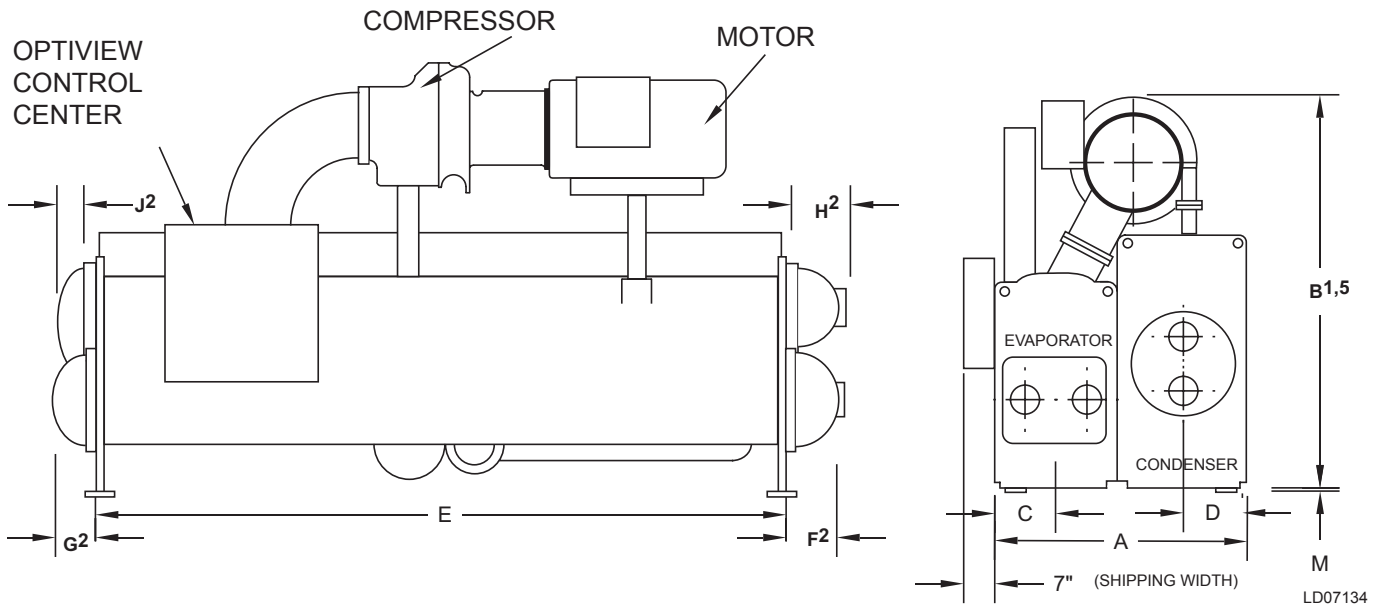

LD07134

ADDITIONAL OPERATING HEIGHT CLEARANCE TO FLOOR	
TYPE OF CHILLER MOUNTING	M
NEOPRENE PAD ISOLATORS	1-3/4" (45)
SPRING ISOLATORS 1" DEFLECTION	1" (25)
DIRECT MOUNT	3/4" (19)

K1 COMPRESSOR, EVAPORATOR-CONDENSER SHELL CODES					
DIM	I-K & K-K	M-M	N-N	P-P	Q-Q
A	7'-6 1/2" (2299)	8'-7" (2616)	8'-7" (2616)	9'-1 1/2" (2781)	9'-1 1/2" (2781)
B	9'-7" (2921)	11'-4" (3454)	11'-4" (3454)	11'-5 1/2" (3493)	11'-5 1/2" (3493)
C	2'-1 1/4" (641)	2'-4 1/2" (724)	2'-4 1/2" (724)	2'-5 1/2" (749)	2'-5 1/2" (749)
D	1'-8" (508)	1'-11" (584)	1'-11" (584)	2'-1 1/4" (641)	2'-1 1/4" (641)
E	14'-0" (4267)	14'-0" (4267)	16'-0" (4877)	14'-0" (4267)	16'-0" (4877)

K2 COMPRESSOR EVAPORATOR-CONDENSER SHELL CODES					
DIM	M-M	M-U	N-N	P-P	Q-Q
A	8'-7" (2616)	9'-6" (2896)	8'-7" (2616)	9'-1 1/2" (2781)	9'-1 1/2" (2781)
B	11'-4" (3454)	11'-10" (3607)	11'-4" (3454)	11'-5" (3480)	11'-5" (3480)
C	2'-4 1/2" (724)	2'-4 1/2" (724)	2'-4 1/2" (724)	2'-5 1/2" (749)	2'-5 1/2" (749)
D	1'-11" (584)	2'-4 1/2" (724)	1'-11" (584)	2'-1 1/4" (641)	2'-1 1/4" (641)
E	14'-0" (4267)	14'-0" (4267)	16'-0" (4877)	14'-0" (4267)	16'-0" (4877)

Dimensions (Cont'd)

K COMPRESSOR UNITS

K3 COMPR., EVAP.-COND. SHELL CODES			
	N-N	Q-Q	R-R
A	8'-7" (2616)	9'-1 1/2" (2781)	9'-9" (2972)
B	10'-8" (3251)	11'-6" (3505)	11'-10" (3607)
C	2'-4 1/2" (724)	2'-5 1/2" (749)	2'-8" (813)
D	1'-11" (584)	2'-1 1/4" (641)	2'-3 1/2" (699)
E	16'-0" (4877)	16'-0" (4877)	16'-0" (4877)

K4 COMPRESSOR, EVAPORATOR- CONDENSER SHELL CODES					
DIM	R-R	S-S	S-V	X-T	X-X
A	9'-9" (2972)	9'-9" (2972)	10'-3" (3124)	10'-10" (3302)	11'-3" (3429)
B	11'-11" (3632)	11'-11" (3632)	12'-4" (3759)	12'-4" (3759)	12'-4" (3759)
C	2'-8" (813)	2'-8" (813)	2'-8" (813)	2'-11 1/2" (902)	2'-11 1/2" (902)
D	2'-3 1/2" (699)	2'-3 1/2" (699)	2'-5 1/2" (749)	2'-5 1/2" (749)	2'-8" (813)
E	16'-0" (4877)	18'-0" (5486)	18'-0" (5486)	16'-0" (4877)	16'-0" (4877)

K7 COMPR., EVAP.-COND SHELL CODES			
DIM	W-W	Z-Y	Z-Z
A	10'-3" (3124)	12'-7" (3835)	11'-3" (3429)
B	12'-2" (3708)	14'-1 5/8" (4308)	12'-10" (3912)
C	2'-8" (813)	2'-11 1/2" (902)	2'-11 1/2" (902)
D	2'-5 1/2" (749)	3'-4" (1016)	2'-8" (813)
E	22'-0" (6706)	18'-0" (5486)	18'-0" (5486)

NOTES:

- All dimensions are ft-inches (mm).
- All dimensions are approximate. Certified dimensions are available on request.
- For all waterboxes (compact boxes shown above), determine overall unit length by adding waterbox depth to tube sheet length.
- Water nozzles can be located on either end of unit. Add 1/2" (12mm) to nozzle length for flanges connections.
- To determine overall height, add dimension "M" for the appropriate isolator type.
- Use of motors with motor hoods may increase overall unit dimensions.

Dimensions (Cont'd)

EVAPORATORS – COMPACT WATER BOXES – A THRU L EVAPORATORS

1-PASS

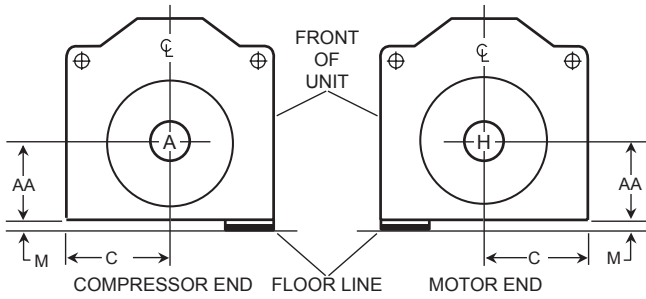

NOZZLE ARRANGEMENTS		
NO. OF PASSES	EVAPORATOR	
	IN	OUT
1	A	H
	H	A

2-PASS

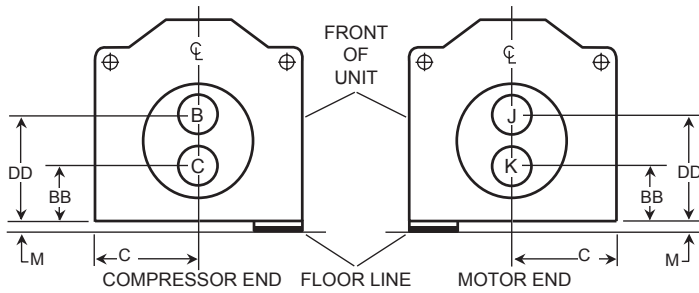

NOZZLE ARRANGEMENTS		
NO. OF PASSES	EVAPORATOR	
	IN	OUT
2	C	B
	K	J

3-PASS

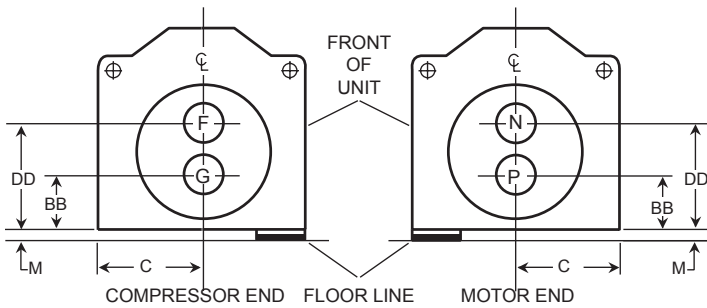

LD07598a

NOZZLE ARRANGEMENTS		
NO. OF PASSES	EVAPORATOR	
	IN	OUT
3	G	N
	P	F

Dimensions (Cont'd)

EVAPORATORS – COMPACT WATER BOXES – A THRU L EVAPORATORS

COMPACT WATER BOXES - 150 PSI ROUND									
EVAPORATOR SHELL CODE	NOZZLE PIPE SIZE(IN)			EVAPORATOR NOZZLE DIMENSIONS					
	NO. OF PASSES			C	1-PASS	2-PASS		3-PASS	
	1	2	3		AA5	BB5	DD5	BB5	DD5
A	8	6	4	1'-3 1/2" (394)	1'-10" (559)	1'-2" (356)	2'-6" (762)	1'-2" (356)	2'-6" (762)
C,D	10	8	6	1'-5 1/2" (445)	2'-0" (610)	1'-3" (381)	2'-9" (838)	1'-3" (381)	2'-9" (838)
E,F	14	10	8	1'-7" (483)	2'-2" (660)	1'-4" (406)	3'-0" (914)	1'-4" (406)	3'-0" (914)
G,H	14	10	8	2'-0" (610)	2'-3 1/2" (699)	1'-3 1/2" (394)	3'-3 1/2" (1003)	1'-3 1/2" (394)	3'-3 1/2" (1003)
I, J, K, L	16	12	10	2'-1 1/4" (641)	2'-6" (762)	1'-5" (432)	3'-7" (1092)	1'-5" (432)	3'-7" (1092)

NOTES:

1. All dimensions are ft-inches (mm).
2. All dimensions are approximate. Certified dimensions are available on request.
3. For all waterboxes (compact boxes shown above), determine overall unit length by adding waterbox depth to tube sheet length.
4. Water nozzles can be located on either end of unit. Add 1/2" (12mm) to nozzle length for flanges connections.
5. To determine overall height, add dimension "M" for the appropriate isolator type.
6. Use of motors with motor hoods may increase overall unit dimensions.

Dimensions (Cont'd)

EVAPORATORS – COMPACT WATERBOXES – M THRU Z EVAPORATORS

1-PASS

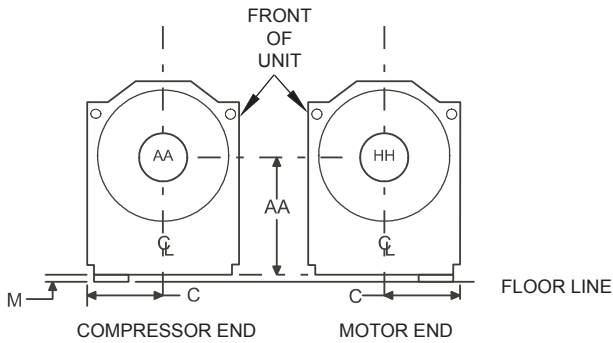

SHELL CODE	1 PASS	
	IN	OUT
M-Z	AA	HH
	HH	AA

2-PASS

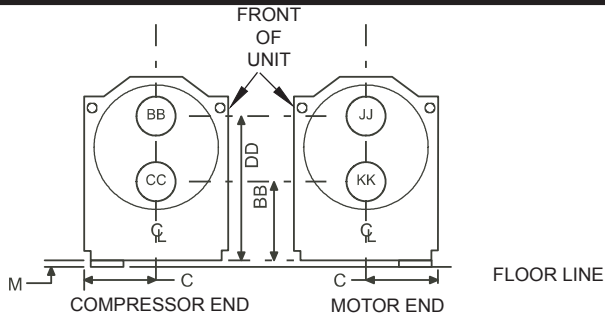

SHELL CODE	2 PASS	
	IN	OUT
M,N,P,Q	CC	BB
	KK	JJ

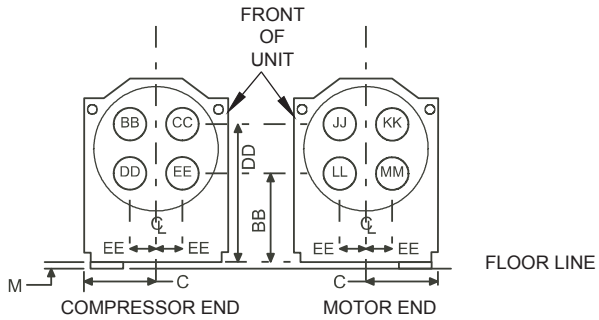

SHELL CODES	2 PASS	
	IN	OUT
R, S, W X & Z	DD	CC
	EE	BB
	LL	KK
	MM	JJ

3-PASS

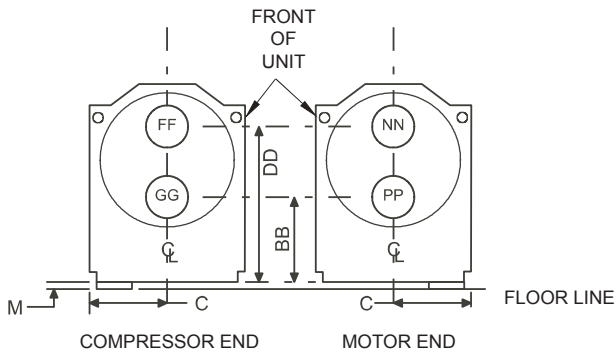

SHELL CODES	3 PASS	
	IN	OUT
M-Z	GG	NN
	PP	FF

LD07173a

Dimensions (Cont'd)

EVAPORATORS – COMPACT WATERBOXES – M THRU Z EVAPORATORS

COMPACT WATER BOXES - 150 PSI										
EVAP SHELL CODE	NOZZLE PIPE SIZE(IN)			EVAPORATOR NOZZLE DIMENSIONS (FT-IN.)						
	NO. OF PASSES			C	1-PASS AA ⁴	2-PASS			3-PASS	
	1	2	3			BB ⁴	DD ⁴	EE	BB ⁴	DD ⁴
M,N	18	14	12	2'-4 1/2" (724)	3'-0" (914)	1'-8 1/2" (521)	4'-3 1/2" (1308)	-	1'-8 1/2" (521)	4'-3 1/2" (1308)
P,Q	18	14	12	2'-5 1/2" (749)	3'-1 1/2" (953)	1'-10" (559)	4'-5" (1346)	-	1'-10" (559)	4'-5" (1346)
PF, QF, QH, QV, QT	20	16	12	2'-5 1/2" (749)	3'-1 1/2" (953)	1'-11 1/2" (597)	4'-3 1/2" (1308)	-	1'-11 1/2" (597)	4'-3 1/2" (1308)
R,S,W	20	18	14	2'-8" (813)	3'-5 1/4" (1048)	2'-4 1/2" (724)	4'-6 1/2" (1384)	0'-10 1/2" (267)	2'-1" (635)	4'-10" (1473)
X,Z	20	18	14	2'-11 1/2" (902)	3'-9 3/4" (1162)	2'-8 3/4" (832)	4'-10 3/4" (1492)	0'-11" (279)	2'-2 7/8" (683)	5'-4 5/8" (1641)

NOTES:

1. All dimensions are ft-inches (mm).
2. All dimensions are approximate. Certified dimensions are available on request.
3. For all waterboxes (compact boxes shown above), determine overall unit length by adding waterbox depth to tube sheet length.
4. Water nozzles can be located on either end of unit. Add 1/2" (12mm) to nozzle length for flanges connections.
5. Add dimension "M" as shown on page 84 for the appropriate isolator type.
6. Use of motors with motor hoods may increase overall unit dimensions.

Dimensions (Cont'd)

EVAPORATORS – COMPACT WATERBOXES



ONE PASS EVAPORATORS, CODES									
DIM.	A	C,D	E,F	G,H	I,J,K,L	M,N	P,Q	R,S,W	X,Z
F	1'-2 1/4" (362)	1'-3" (381)	1'-3 1/2" (394)	1'-3 3/4" (400)	1'-5 1/2" (445)	1'-11 5/8" (565)	1'-11 5/8" (600)	2'-0 5/8" (613)	2'-1 3/4" (600)

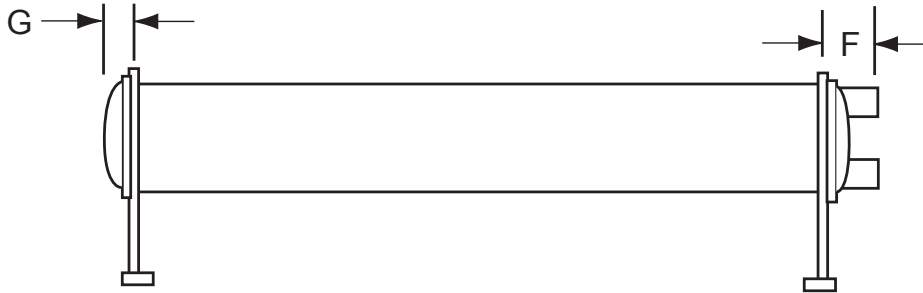

TWO PASS EVAPORATORS, CODES									
DIM.	A	C,D	E,F	G,H	I,J,K,L	M,N	P,Q	R,S,W	X,Z
F	1'-2 1/4" (362)	1'-3" (381)	1'-3 1/2" (394)	1'-3 3/4" (400)	1'-5 1/2" (445)	1'-11 5/8" (565)	1'-11 5/8" (600)	2'-0 5/8" (613)	2'-1 3/4" (600)
G	0'-6 1/2" (165)	0'-7" (178)	0'-7 1/2" (191)	0'-7 3/4" (197)	0'-9 1/2" (241)	1'-3 5/8" (365)	1'-3 5/8" (391)	1'-4 3/4" (391)	1'-5 3/4" (416)



THREE PASS EVAPORATORS, CODES									
DIM.	A	C,D	E,F	G,H	I,J,K,L	M,N	P,Q	R,S,W	X,Z
F	1'-2 1/4" (362)	1'-3" (381)	1'-3 1/2" (394)	1'-3 3/4" (400)	1'-5 1/2" (445)	1'-11 5/8" (565)	1'-11 5/8" (600)	2'-0 5/8" (613)	2'-1 3/4" (600)

LD07619a

THIS PAGE INTENTIONALLY LEFT BLANK.

Dimensions (Cont'd)

CONDENSERS – COMPACT WATER BOXES

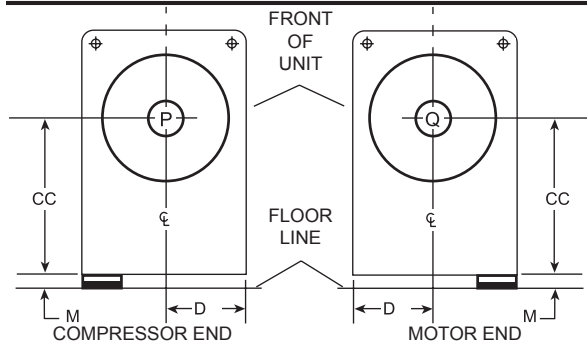

1-PASS

NOZZLE ARRANGEMENTS ⁷		
NO. OF PASSES	CONDENSER	
	IN	OUT
1	P	Q
	Q	P

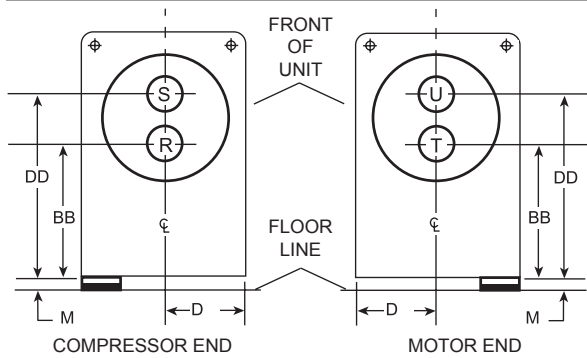

2-PASS

NOZZLE ARRANGEMENTS ⁷		
NO. OF PASSES	CONDENSER	
	IN	OUT
2	R	S
	T	U

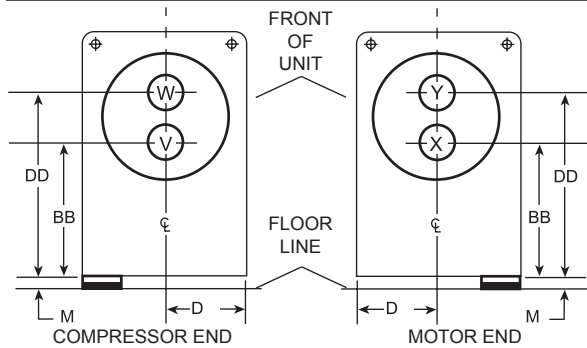

3-PASS

NOZZLE ARRANGEMENTS ⁷		
NO. OF PASSES	CONDENSER	
	IN	OUT
3	V	Y
	X	W

LD07131a

Dimensions (Cont'd)

CONDENSERS – COMPACT WATER BOXES

COMPACT WATER BOXES - 150 PSI ROUND									
CONDENSER SHELL CODE	NOZZLE PIPE SIZE(IN)			D	1-PASS	2-PASS		3-PASS	
	NO. OF PASSES				CC ⁵	BB ⁵	DD ⁵	BB ⁵	DD ⁵
	1	2	3						
A	10	6	6	1'-3" (381)	2'-4" (711)	1'-9 1/2" (546)	2'-10 1/2" (876)	1'-9 1/2" (546)	2'-10 1/2" (876)
C,D	12	8	6	1'-3 1/2" (394)	2'-6" (762)	1'-10 3/8" (568)	3'-1 5/8" (956)	1'-10 3/8" (568)	3'-1 5/8" (956)
E,F	14	10	8	1'-5 1/2" (445)	2'-8" (813)	1'-11 3/4" (603)	3'-4 1/4" (1022)	1'-11 3/4" (603)	3'-4 1/4" (1022)
J,K,L	16	10	10	1'-8" (508)	3'-0" (914)	2'-3" (686)	3'-9" (1143)	2'-3" (686)	3'-9" (1143)
M,N	20	14	10	1'-11" (584)	3'-6" (1067)	2'-6 3/8" (772)	4'-5 5/8" (1362)	2'-6 3/8" (772)	4'-5 5/8" (1362)
P,Q	20	16	14	2'-1 1/4" (641)	3'-8" (1118)	2'-7" (787)	4'-9" (1448)	2'-7" (787)	4'-9" (1448)
R,S	20	18	14	2'-3 1/2" (699)	3'-10 1/2" (1181)	2'-9 1/2" (851)	4'-11 1/2" (1511)	2'-9 1/2" (851)	4'-11 1/2" (1511)
T,V,W	24	18	16	2'-5 1/2" (749)	3'-11 1/2" (1207)	2'-9" (838)	5'-2" (1575)	2'-9" (838)	5'-2" (1575)
X,Z	24	20	16	2'-8" (813)	4'-1 1/4" (1251)	2'-9 1/4" (845)	5'-5 1/4" (1657)	2'-9 1/4" (845)	5'-5 1/4" (1657)

NOTES:

- All dimensions are ft-inches (mm).
- Standard water nozzles are furnished as welding stub-outs with ANSI/AWWA C-606 grooves, allowing the option of welding, flanges, or use of ANSI/AWWA C-606 couplings. Factory-installed, class 150 (ANSI B16.5, round slip-on, forged carbon steel with 1.6 mm raised face), water flanges nozzles are optional (add 13 mm to nozzle length). Companion flanges, nuts, bolts, and gaskets are not furnished.
- One, two and three pass nozzle arrangements are available only in pairs shown and for all shell codes. Any pair of evaporator nozzles may be used in combination with any pair of condenser nozzles.
- Evaporator and condenser water must enter the water box through the bottom connection to achieve rated performance.
- Connected piping should allow for removal of compact water boxes for tube access and cleaning.
- Add dimension "M" as shown on page 84 for the appropriate isolator type.
- Standard 150 psi (1034 kPa) design pressure water boxes shown.
- Shell codes R,S,T,V,W,X, & Z use double letter nozzle codes in the same orientation as the single letter e.g. P = PP.

Dimensions (Cont'd)

CONDENSERS – COMPACT WATER BOXES

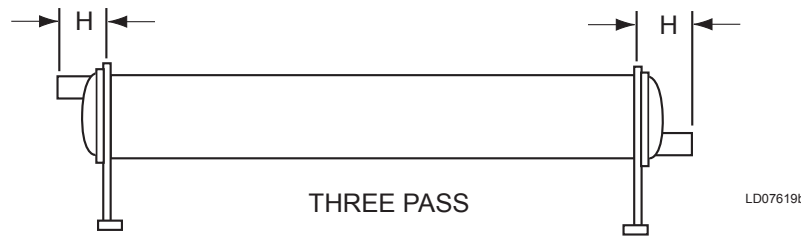
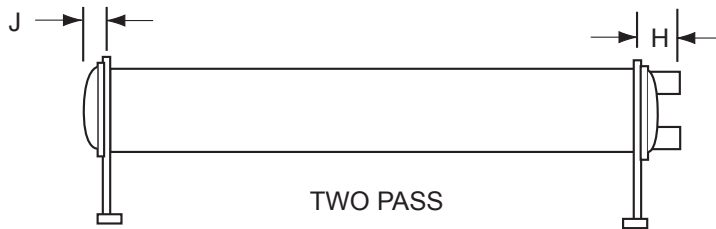
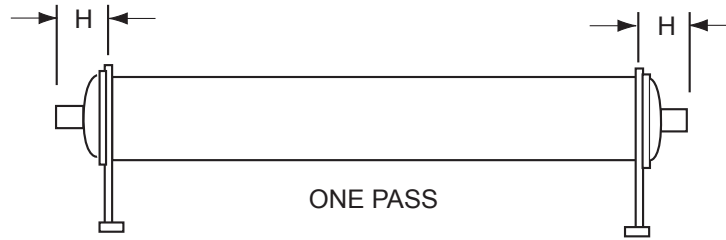

SINGLE BUNDLE CONDENSERS, CODES									
DIM.	A	C,D	E,F	J,K,L	M,N	P,Q	R,S	T,V,W	X,Z
H	1'-1 7/8" (352)	1'-1 7/8" (352)	1'-3" (381)	1'-3 1/2" (394)	1'-3 3/8" (391)	1'-5 1/2" (445)	1'-8 3/4" (527)	1'-10 1/2" (572)	1'-11 5/8" (600)
J	0'-5 7/8" (149)	0'-6 1/2" (165)	0'-7" (178)	0'-7 1/2" (191)	0'-7 3/4" (197)	0'-9 1/2" (241)	1'-2 3/8" (365)	1'-3 3/8" (391)	1'-4 3/8" (416)

DOUBLE BUNDLE HEAT RECOVERY CONDENSERS, CODES										
DIM.	B		I		O		U		Y	
	TOWER	HEATING	TOWER	HEATING	TOWER	HEATING	TOWER	HEATING	TOWER	HEATING
H	1'-6 1/2" (470)	1'-5" (432)	1'-7 1/2" (495)	1'-4 3/4" (425)	1'-9 1/2" (546)	1'-6" (457)	1'-10 1/4" (565)	1'-8" (508)	2'-4 3/4" (730)	1'-10 1/2" (572)
J	0'-10 1/2" (267)	0'-9" (229)	0'-11 1/2" (292)	0'-8 3/4" (222)	1'-1 1/2" (343)	0'-10" (254)	1'-2 1/4" (362)	1'-0" (305)	1'-8 3/4" (527)	1'-2 1/2" (368)

Dimensions (Cont'd)

HEAT RECOVERY UNITS

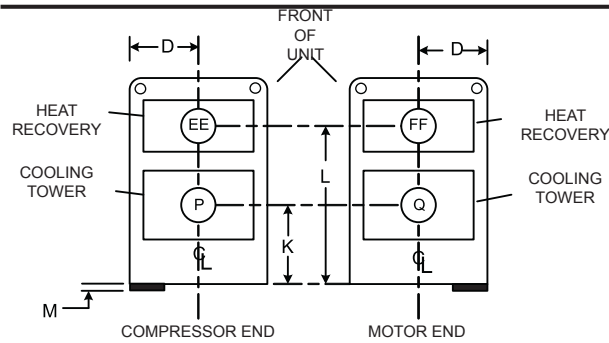

1-PASS

1 PASS NOZZLE ARRANGEMENTS		
	IN	OUT
HEAT RECOVERY	EE	FF
	FF	EE
COOLING TOWER	P	Q
	Q	P

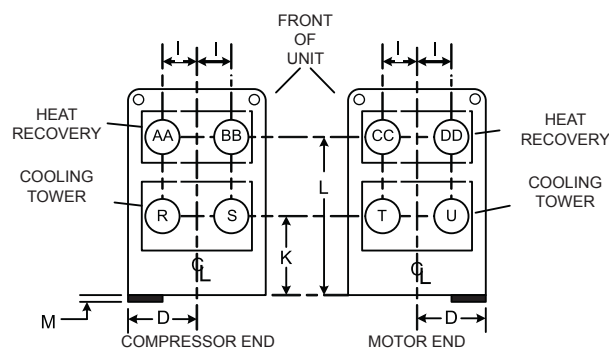

2-PASS

2 PASS NOZZLE ARRANGEMENTS		
	IN	OUT
HEAT RECOVERY	AA	BB
	BB	AA
	CC	DD
	DD	CC
COOLING TOWER	R	S
	S	R
	T	U
	U	T

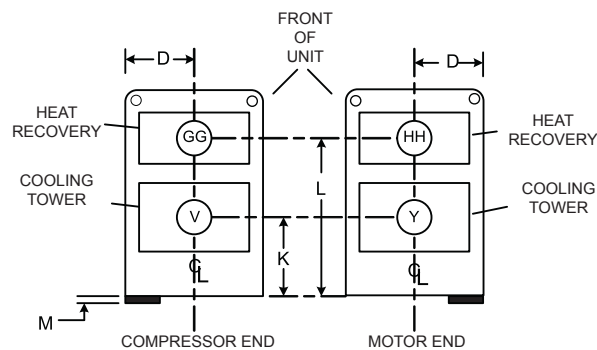

3-PASS

3 PASS NOZZLE ARRANGEMENTS		
	IN	OUT
HEAT RECOVERY	GG	HH
	HH	GG
COOLING TOWER	V	Y
	Y	V

LD18382

COMPACT WATER BOXES - 150 PSI (RECTANGULAR)										
CONDENSER SHELL CODE	NOZZLE PIPE SIZE (IN)						1, 2 OR 3 PASS			2 PASS
	MAIN BUNDLE			HEAT RECOVERY BUNDLE						
	NUMBER OF PASSES			NUMBER OF PASSES			D	K	L	I
	1	2	3	1	2	3				
B	10	8	6	10	8	6	1'-8 7/8" (530)	1'-9 1/4" (540)	3'-6 1/2" (1080)	0'-9 1/16" (230)
I	14	10	8	12	8	8	1'-11 3/8" (594)	1'-10 1/4" (565)	3'-8 1/8" (1121)	0'-10 1/8" (257)
O	16	12	10	14	10	8	2'-3 3/8" (695)	2'-0 3/8" (619)	4'-1 1/8" (1248)	0'-11 13/16" (300)
U	18	14	10	16	12	10	2'-4 1/2" (724)	2'-11 3/16" (894)	5'-2 13/16" (1595)	1'-0 3/8" (314)
Y	24	20	16	20	18	16	3'-4" (1016)	3'-3 15/16" (1014)	6'-3 7/8" (1927)	1'-5 7/8" (454)

Add dimension "M" as shown on page 84.

Dimensions (Cont'd)

EVAPORATORS – MARINE WATERBOXES

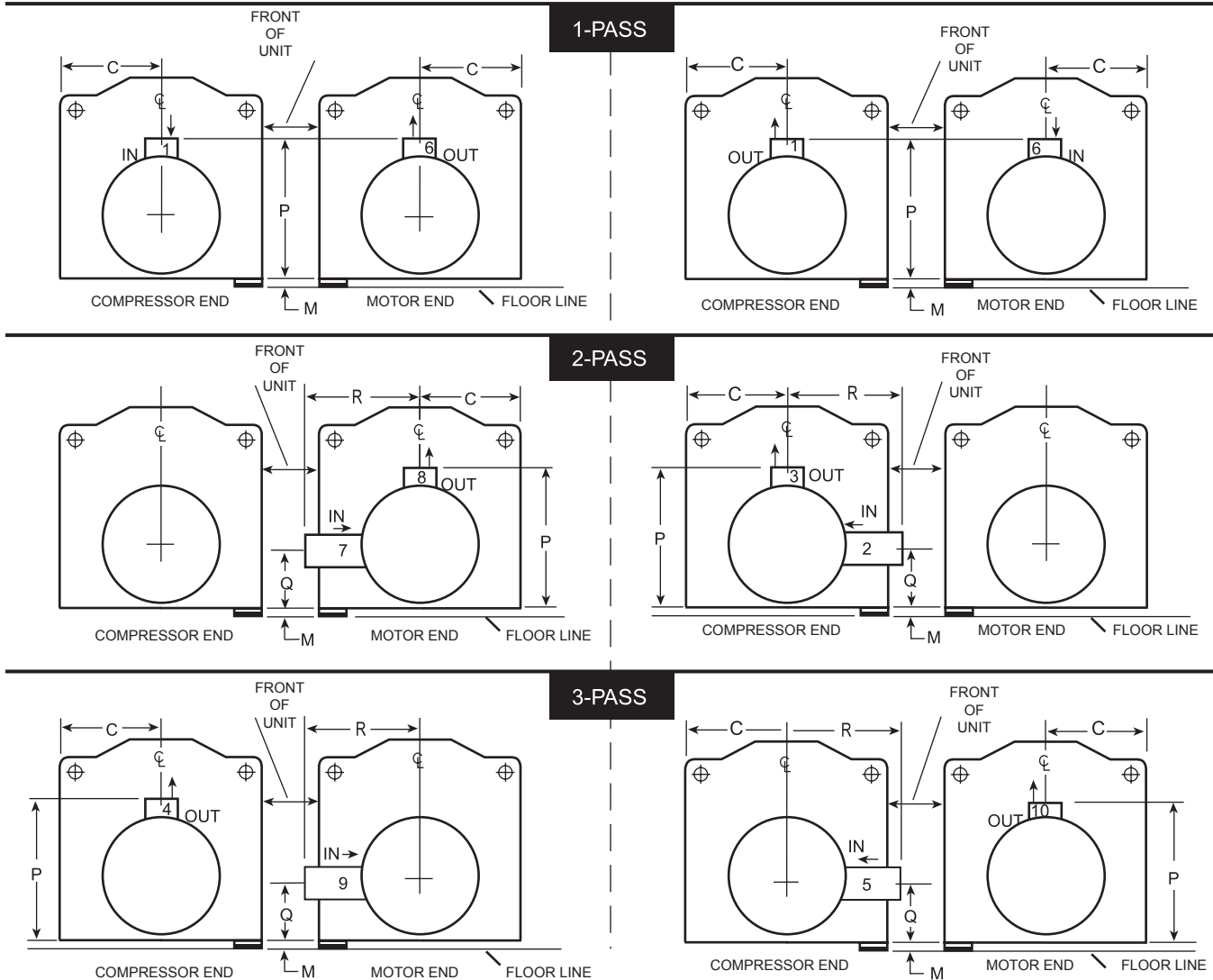

LD07175a

NOTES:

1. All dimensions are ft-inches (mm).
2. All dimensions are approximate. Certified dimensions are available on request.
3. For all waterboxes (compact boxes shown above), determine overall unit length by adding waterbox depth to tube sheet length.
4. Water nozzles can be located on either end of unit. Add 1/2" (12mm) to nozzle length for flanges connections.
5. Add dimension "M" as shown on page 84 for the appropriate isolator type.
6. Use of motors with motor hoods may increase overall unit dimensions.

Dimensions (Cont'd)**EVAPORATORS – MARINE WATERBOXES**

MARINE WATER BOXES - 150 PSI ROUND											
EVAPORATOR SHELL CODE	NOZZLE PIPE SIZE(IN)										
	NO. OF PASSES			1-PASS	2-PASS			3-PASS			
	1	2	3	C	P ⁵	P ⁵	Q ⁵	R	P ⁵	Q ⁵	R
A	8	6	4	1'-3 1/2" (394)	3'-7" (1092)	3'-7" (1092)	0'-11" (279)	1'-3 1/4" (387)	3'-7" (1092)	0'-11" (279)	1'-3 1/4" (387)
C,D	10	8	6	1'-5 1/2" (445)	3'-11" (1194)	3'-11" (1194)	0'-10" (254)	1'-6 1/2" (470)	3'-11" (1194)	0'-10" (254)	1'-6 1/2" (470)
E,F	14	10	8	1'-7 1/2" (495)	4'-3" (1295)	4'-3" (1295)	0'-11" (279)	1'-9 1/2" (546)	4'-3" (1295)	0'-11" (279)	1'-9 1/2" (546)
G,H	14	10	8	2'-0" (610)	4'-7 3/8" (1407)	4'-7 3/8" (1407)	0'-10 1/2" (267)	1'-11 1/2" (597)	4'-7 3/8" (1407)	0'-10 1/2" (267)	1'-11 1/2" (597)
I,J,K,L	16	12	10	2'-1 1/4" (641)	5'-0 3/8" (1534)	5'-0 3/8" (1534)	0'-10 1/2" (267)	2'-2 1/2" (673)	5'-0 3/8" (1534)	0'-10 1/2" (267)	2'-2 1/2" (673)
M,N	18	14	12	2'-4 1/2" (724)	5'-8 1/2" (1740)	5'-8 1/2" (1740)	1'-2" (356)	2'-2 1/2" (673)	5'-8 1/2" (1740)	1'-2" (356)	2'-4 3/4" (730)
P,Q	18	14	12	2'-5 1/2" (749)	6'-0 1/8" (1832)	6'-0 1/8" (1832)	1'-3" (381)	2'-6 1/2" (775)	6'-0 1/8" (1832)	1'-3" (381)	2'-6 1/2" (775)
PF, QF, QH, QT, QV	20	16	12	2'-5 1/2" (749)	6'-0 1/8" (1832)	6'-0 1/8" (1832)	1'-4 1/2" (419)	2'-6 1/2" (775)	6'-0 1/8" (1832)	1'-4 1/2" (419)	2'-6 1/2" (775)
R,S	20	18	14	2'-8" (813)	6'-5 7/8" (1978)	6'-5 7/8" (1978)	1-3 3/4" (57)	3'-0 1/8" (918)	6'-5 7/8" (1978)	1-3 3/4" (57)	3'-0 1/8" (918)
W	20	18	14	2'-8" (813)	6'-5 7/8" (1978)	6'-5 7/8" (1978)	1-3 3/4" (57)	3'-0 1/8" (918)	6'-5 7/8" (1978)	1-3 3/4" (57)	3'-0 1/8" (918)
X,Z	20	18	14	2'-11 1/2" (902)	7'-1 3/8" (2169)	7'-1 3/8" (2169)	1'-9 1/4" (540)	3'-0 3/4" (933)	7'-1 3/8" (2169)	1'-9 1/4" (540)	3'-0 3/4" (933)

Dimensions (Cont'd)

EVAPORATORS – MARINE WATERBOXES

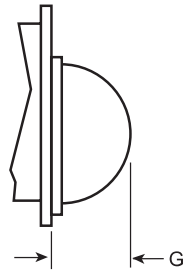
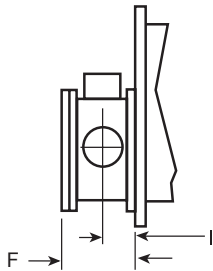

(2-PASS RETURN HEAD)

LD01342b

EVAPORATOR	
1-PASS	
IN	OUT
1	6
6	1

EVAPORATOR	
2-PASS	
IN	OUT
2	3
7	8

EVAPORATOR	
3-PASS	
IN	OUT
5	10
9	4

EVAPORATOR SHELL CODE	1-PASS		2-PASS			3-PASS	
	F	I	F	G	I	F	I
A	1'-7" (483)	0'-8 3/4" (222)	1'-5" (432)	0'-6 1/2" (165)	0'-7 3/4" (197)	1'-5" (432)	0'-7 3/4" (197)
C,D	1'-10 3/4" (578)	0'-10 5/8" (270)	1'-8 5/8" (524)	0'-7" (178)	0'-9 1/2" (241)	1'-8 5/8" (524)	0'-9 1/2" (241)
E,F	2'-1 3/4" (654)	1'-0 1/8" (308)	1'-10" (559)	0'-7 1/2" (191)	0'-10 1/4" (260)	1'-10" (559)	0'-10 1/4" (260)
G,H	2'-2" (660)	0'-11 7/8" (302)	1'-10 1/2" (572)	0'-11 1/4" (286)	0'-10 1/4" (260)	1'-10 1/2" (572)	0'-10 1/4" (260)
i,J,K,L	2'-3" (686)	1'-0 3/8" (314)	1'-11 1/2" (597)	0'-9 1/2" (241)	0'-10 9/16" (268)	1'-11 1/2" (597)	0'-10 1/2" (267)
M,N	2'-6" (762)	1'-1 1/2" (343)	2'-2" (660)	1'-0 1/8" (308)	0'-11 1/2" (292)	2'-2" (660)	0'-11 1/2" (292)
P,Q	2'-6" (762)	1'-1 1/2" (343)	2'-2" (660)	1'-1 1/2" (343)	0'-11 1/2" (292)	2'-2" (660)	0'-11 1/2" (292)
QT,QV	2'-8" (813)	1'-2 1/2" (368)	2'-4" (711)	1'-1 1/2" (343)	1'-0 1/2" (318)	2'-4" (711)	1'-0 1/2" (318)
R,S,W	2'-8" (813)	1'-2 5/8" (371)	2'-6" (762)	1'-2 1/2" (368)	1'-1 5/8" (346)	2'-6" (762)	1'-1 5/8" (346)
X,Z	2'-9" (838)	1'-2 5/8" (371)	2'-6" (762)	1'-3 1/2" (394)	1'-1 5/8" (346)	2'-6" (762)	1'-1 5/8" (346)

THIS PAGE INTENTIONALLY LEFT BLANK.

Dimensions (Cont'd)

CONDENSERS – MARINE WATERBOXES

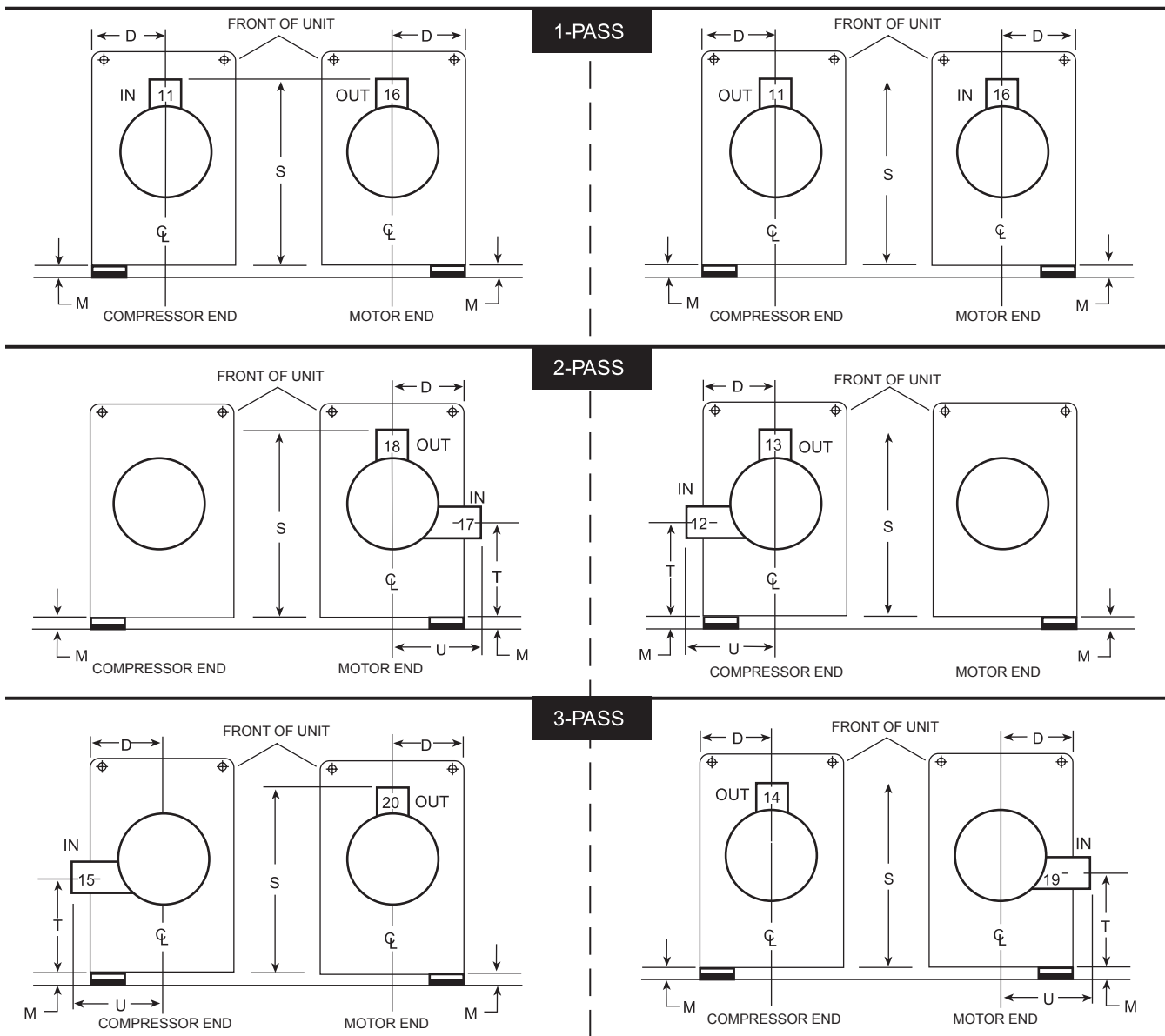

LD07178a

Dimensions (Cont'd)

CONDENSERS – MARINE WATERBOXES

MARINE WATER BOXES - 150 PSI ROUND											
CONDENSER SHELL CODE	NOZZLE PIPE SIZE(IN)			1-PASS	2-PASS			3-PASS			
	NO. OF PASSES				D	S ⁵	S ⁵	T ⁵	U	S ⁵	T ⁵
	1	2	3								
A	10	6	6	1'-3" (381)	3'-11" (1194)	3'-11" (1194)	1'-8" (508)	1'-3 3/8" (391)	3'-11" (1194)	1'-8" (508)	1'-3 3/8" (391)
C,D	12	8	6	1'-3 1/2" (394)	4'-3" (1295)	4'-3" (1295)	1'-8" (508)	1'-6 1/2" (470)	4'-3" (1295)	1'-8" (508)	1'-6 1/2" (470)
E,F	14	10	8	1'-5 1/2" (445)	4'-7" (1397)	4'-7" (1397)	1'-10" (559)	1'-9" (533)	4'-7" (1397)	1'-10" (559)	1'-9" (533)
J,K,L	16	10	10	1'-8" (508)	5'-1" (1549)	5'-1" (1549)	1'-9" (533)	1'-9 1/2" (546)	5'-1" (1549)	1'-9" (533)	1'-9 1/2" (546)
M,N	20	14	10	1'-11" (584)	5'-9 7/8" (1775)	5'-9 7/8" (1775)	2'-4" (711)	2'-1 1/2" (648)	5'-9 7/8" (1775)	2'-4" (711)	2'-1 1/2" (648)
P,Q	20	16	14	2'-1 1/4" (641)	6'-2 3/8" (1889)	6'-2 3/8" (1889)	2'-4 1/2" (724)	2'-5 1/2" (749)	6'-2 3/8" (1889)	2'-4 1/2" (724)	2'-5 1/2" (749)
R,S	20	18	14	2'-3 1/2" (699)	6'-7" (2007)	6'-7" (2007)	2'-6 1/2" (775)	2'-8 1/2" (826)	6'-7" (2007)	2'-6 1/2" (775)	2'-8 1/2" (826)
T,V,W	24	18	16	2'-5 1/2" (749)	6'-10 1/4" (2089)	6'-10 1/4" (2089)	2'-6" (762)	2'-10" (864)	6'-10 1/4" (2089)	2'-6" (762)	2'-10" (864)
X,Z	24	20	16	2'-8" (813)	7'-2" (2184)	7'-2" (2184)	2'-7 3/4" (806)	2'-11 1/2" (902)	7'-2" (2184)	2'-7 3/4" (806)	2'-11 1/2" (902)

NOTES:

- All dimensions are ft-inches (mm).
- Standard water nozzles are furnished as welding stub-outs with ANSI/AWWA C-606 grooves, allowing the option of welding, flanges, or use of ANSI/AWWA C-606 couplings. Factory-installed, class 150 (ANSI B16.5, round slip-on, forged carbon steel with 1.6 mm raised face), water flanges nozzles are optional (add 13 mm to nozzle length). Companion flanges, nuts, bolts, and gaskets are not furnished.
- One, two and three pass nozzle arrangements are available only in pairs shown and for all shell codes. Any pair of evaporator nozzles may be used in combination with any pair of condenser nozzles.
- Evaporator and condenser water must enter the water box through the bottom connection to achieve rated performance.
- Connected piping should allow for removal of compact water boxes for tube access and cleaning.
- Add dimension "M" as shown on page 84 for the appropriate isolator type.
- Standard 150 psi (1034 kPa) design pressure water boxes shown.
- Shell codes R,S,T,V,W,X, & Z use double letter nozzle codes in the same orientation as the single letter e.g. P = PP.

Dimensions (Cont'd)

CONDENSERS – MARINE WATER BOXES

Heat Recovery Units - Main (Tower) Circuit Only

1-PASS

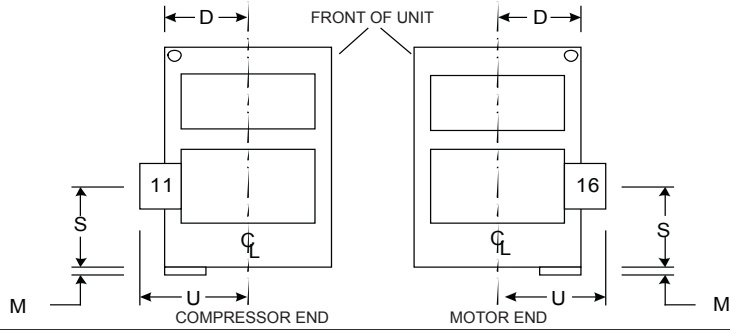

2-PASS

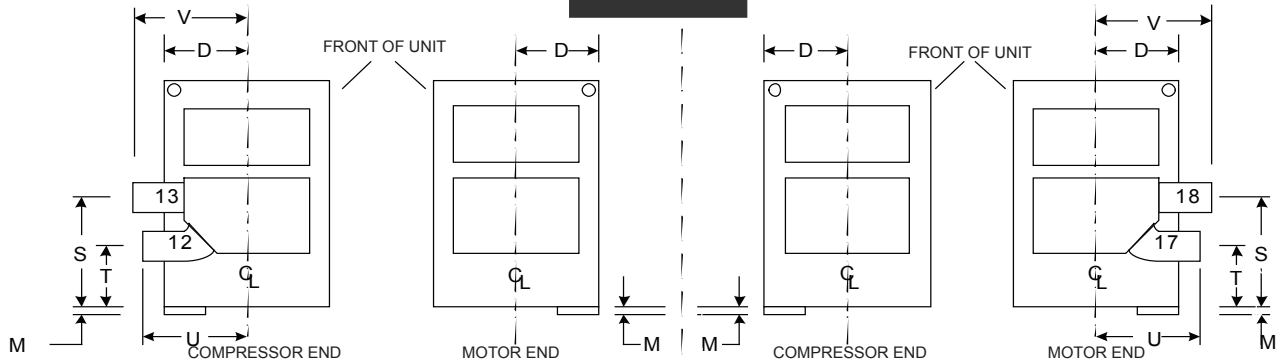

3-PASS

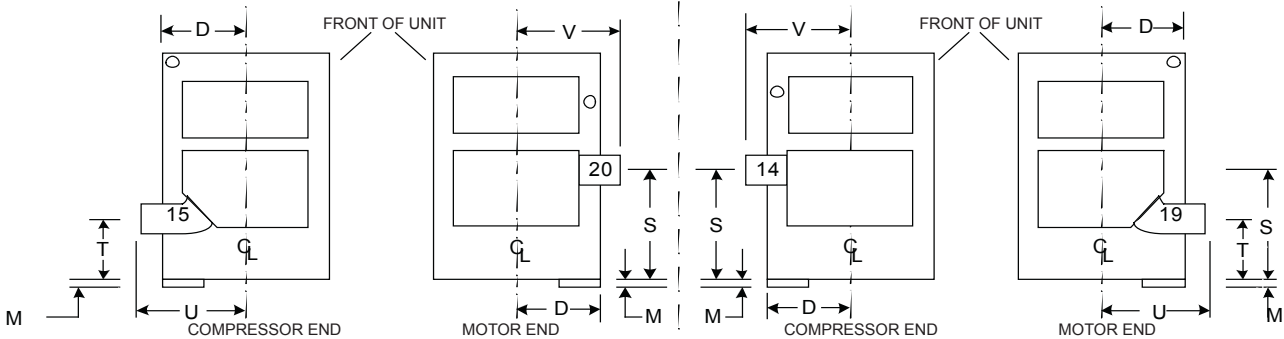

LD18383

CONDENSER NOZZLE OPTIONS	COOLING WATER	
	IN	OUT
1 PASS	11	16
	16	11
2 PASS	12	13
	17	18
3 PASS	15	20
	19	14

Dimensions (Cont'd)

CONDENSERS – MARINE WATER BOXES Heat Recovery Units - Main (Tower) Circuit Only

MARINE WATER BOXES - 150 PSI (RECTANGULAR)															
COND SHELL CODE	NOZZLE PIPE SIZE (IN)			1 PASS				2 PASS				3 PASS			
	NO. OF PASSES			D	S	U	S	T	U	V	S	T	U	V	
	1	2	3												
B	10	8	6	1'-8 7/8" (530)	1'-9 1/4" (540)	2'-6 3/4" (781)	2'-3 7/16" (697)	1'-1 15/16" (354)	2'-4 3/4" (730)	2'-7 1/8" (791)	2'-4 1/2" (724)	1'-5 1/2" (445)	2'-6 3/4" (781)	2'-6 3/4" (781)	
I	14	10	8	1'-11 3/8" (594)	1'-10 1/4" (565)	2'-9 3/8" (848)	2'-4 1/2" (724)	1'-1" (330)	2'-5 1/8" (740)	2'-10 5/8" (879)	2'-5 1/2" (749)	1'-6 3/8" (467)	2'-9 1/8" (841)	2'-9 1/8" (841)	
O	16	12	10	2'-3 3/8" (695)	2'-0 3/8" (619)	3'-2 3/8" (975)	2'-7 1/8" (791)	1'-1 3/8" (340)	2'-10 1/4" (870)	3'-4 1/2" (1029)	2'-8 3/8" (822)	1'-7 5/8" (498)	3'-1 7/8" (962)	3'-1 7/8" (962)	
U	18	14	10	2'-4 1/2" (724)	2'-11 3/16" (894)	3'-5 9/16" (1056)	3'-6 9/16" (1081)	1'-11 3/16" (589)	3'-1 7/8" (962)	3'-7 1/2" (1105)	3'-8 3/16" (1122)	2'-5 15/16" (760)	3'-0 11/16" (932)	3'-3" (991)	
Y	24	20	16	3'-4" (1016)	3'-3 15/16" (1014)	4'-7 9/16" (1411)	4'-2 5/16" (1278)	1'-10 5/16" (567)	4'-4 3/4" (1340)	4'-11 11/16" (1516)	4'-4 5/16" (1329)	2'-7 7/16" (799)	4'-2 1/16" (1272)	4'-6 13/16" (1392)	

NOTES:

- All dimensions are ft-inches (mm).
- Standard water nozzles are furnished as welding stub-outs with ANSI/AWWA C-606 grooves, allowing the option of welding, flanges, or use of ANSI/AWWA C-606 couplings. Factory-installed, class 150 (ANSI B16.5, round slip-on, forged carbon steel with 1.6 mm raised face), water flanges nozzles are optional (add 13 mm to nozzle length). Companion flanges, nuts, bolts, and gaskets are not furnished.
- One, two and three pass nozzle arrangements are available only in pairs shown and for all shell codes. Any pair of evaporator nozzles may be used in combination with any pair of condenser nozzles.
- Evaporator and condenser water must enter the water box through the bottom connection to achieve rated performance.
- Connected piping should allow for removal of compact water boxes for tube access and cleaning.
- Add dimension "M" as shown on page 84 for the appropriate isolator type.
- Standard 150 psi (1034 kPa) design pressure water boxes shown.
- Shell codes R,S,T,V,W,X, & Z use double letter nozzle codes in the same orientation as the single letter e.g. P = PP.

Dimensions (Cont'd)

CONDENSERS – MARINE WATER BOXES

Heat Recovery Units - Main (Tower) Circuit Only

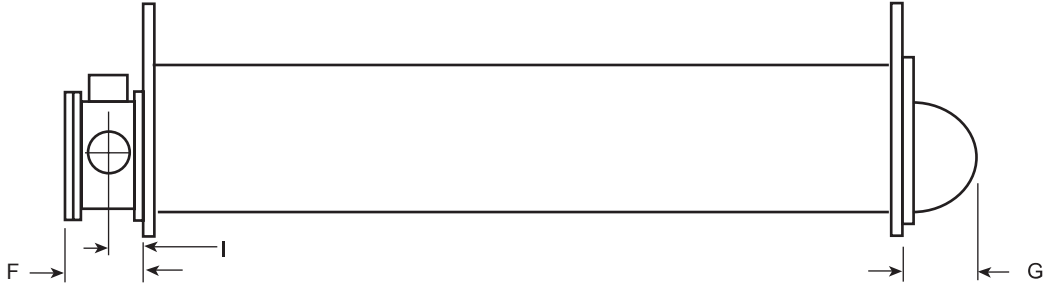

LD01342B_1

CONDENSER	
1-PASS	
IN	OUT
11	16
16	11

CONDENSER	
2-PASS	
IN	OUT
12	13
17	18

CONDENSER	
3-PASS	
IN	OUT
15	20
19	14

Dimensions (Cont'd)**CONDENSERS – MARINE WATER BOXES**

Heat Recovery Units - Main (Tower) Circuit Only

CONDENSER SHELL CODE	1-PASS		2-PASS			3-PASS	
	F	I	F	G	I	F	I
A	1'-9" (533)	0'-9 7/8" (251)	1'-4 3/4" (425)	0'-6" (152)	0'-7 3/4" (197)	1'-4 3/4" (425)	0'-7 3/4" (197)
B6	1'-10 1/2" (572)	0'-10 1/2" (267)	1'-8" (508)	0'-10 1/2" (267)	0'-9 1/4" (235)	1'-8" (508)	0'-9 1/4" (235)
C,D	2'-0" (610)	0'-11 1/8" (283)	1'-7 1/2" (495)	0'-6 3/8" (162)	0'-9" (229)	1'-7 1/2" (495)	0'-9" (229)
E,F	2'-0 1/2" (622)	0'-11 1/2" (292)	1'-10 1/4" (565)	0'-7" (178)	0'-9 7/8" (251)	1'-10 1/4" (565)	0'-9 7/8" (251)
I6	2'-3" (686)	1'-0 3/4" (324)	1'-10 1/2" (572)	0'-11 1/2" (292)	0'-10 1/2" (267)	1'-10 1/2" (572)	0'-10 1/2" (267)
J,K,L	2'-3" (686)	1'-0 1/2" (318)	1'-11" (584)	0'-7 1/2" (191)	0'-10 1/4" (260)	1'-11" (584)	0'-10 1/4" (260)
M,N	2'-8" (813)	1'-2 7/8" (378)	2'-2" (660)	0'-8" (203)	1'-0" (305)	2'-2" (660)	1'-0" (305)
O6	2'-6 1/4" (768)	1'-2 1/4" (362)	2'-1 3/4" (654)	1'-1 1/2" (343)	1'-0" (305)	2'-1 3/4" (654)	1'-0" (305)
P,Q	2'-8" (813)	1'-2 1/2" (368)	2'-4" (711)	0'-9 1/2" (241)	1'-0 1/2" (318)	2'-4" (711)	1'-0 1/2" (318)
R,S	2'-8" (813)	1'-2 1/2" (368)	2'-6" (762)	1'-0" (305)	1'-1 1/2" (343)	2'-6" (762)	1'-1 1/2" (343)
T,V,W	3'-0" (914)	1'-4 1/2" (419)	2'-6" (762)	0'-11" (279)	1'-1 1/2" (343)	2'-6" (762)	1'-1 1/2" (343)
U6	2'-8" (813)	1'-3" (381)	2'-4" (711)	1'-2 1/4" (362)	1'-1" (330)	2'-4" (711)	1'-1" (330)
X,Z	3'-0" (914)	1'-4 5/8" (422)	2'-8" (813)	0'-11" (279)	1'-2 5/8" (371)	2'-8" (813)	1'-2" (356)
Y6	3'-4 3/4" (1035)	1'-7 1/4" (489)	3'-0 1/4" (921)	1'-8 3/4" (527)	1'-5" (432)	3'-0 1/4" (921)	1'-5" (432)

Weights

TABLE 22 - APPROXIMATE UNIT WEIGHT INCLUDING MOTOR² FOR FLOODED EVAPORATOR UNITS

SHELLS	COMPRESSOR	SHIPPING WEIGHT LBS. (KGS.)	OPERATING WEIGHT LBS. (KGS.)	EST. REFRIGERANT CHARGE LBS. (KGS.) ¹
A-A	Q3	13100 (5942)	15000 (6804)	828 (376)
C-B	Q4	18023 (8175)	22323 (10126)	1525 (692)
C-C	Q3, Q4	14920 (6768)	17940 (8138)	1221 (554)
C-C	Q5	15330 (6954)	18350 (8324)	1221 (554)
D-D	Q3, Q4	17215 (7809)	21100 (9571)	1628 (738)
D-D	Q5	17625 (7995)	21510 (9757)	1628 (738)
E-E	Q3, Q4	17950 (8142)	22160 (10052)	1710 (776)
E-E	Q5,Q6,Q7,P7	18360 (8328)	22570 (10238)	1710 (776)
E-I	Q7	23567 (10690)	29384 (13328)	1805 (819)
F-F	Q5,Q6,Q7,P7	18720 (8491)	23880 (10832)	2175 (987)
G-E	P8	20300 (9208)	24200 (10977)	1990 (903)
H-F	P8,P9	23100 (10478)	28000 (12701)	2610 (1184)
J-J	P8,P9	24000 (10886)	29100 (13200)	2550 (1157)
L-L	P8,P9	27400 (12429)	33900 (15377)	3165 (1436)
K-K	H9	28530 (12941)	36000 (16329)	2925 (1327)
K-K	K1	31100 (14107)	36200 (16420)	3248 (1473)
K-O	H9	34483 (15641)	44776 (20310)	3260 (1479)
M-M	H9	34200 (15513)	43600 (19777)	3665 (1662)
M-M	K1,K2	38300 (17373)	47100 (21364)	3665 (1662)
M-U	K2	45178 (20493)	58017 (26316)	3540 (1606)
N-N	K1,K2	40893 (18549)	50800 (23043)	4225 (1916)
N-N	K3	48000 (21773)	54100 (24540)	4225 (1916)
P-P	K1,K2	41500 (18824)	51900 (23542)	3855 (1749)
Q-Q	K1,K2	45300 (20548)	56800 (25764)	4255 (1930)
Q-Q	K3	46000 (20865)	60200 (27307)	4255 (1930)
R-R	K3	52800 (23950)	70300 (31888)	4600 (2087)
R-R	K4	53000 (24041)	70600 (32024)	4600 (2087)
S-S	K4	59000 (26762)	76300 (34609)	4815 (2184)
S-V	K4	60100 (27261)	81300 (36877)	5467 (2480)
X-T	K4	59200 (26853)	80000 (36288)	5338 (2421)
X-X	K4	66000 (29937)	87000 (39463)	5875 (2665)
W-W	K7	79500 (36061)	104000 (47174)	8002 (3630)
Z-Y	K7	95230 (43196)	123015 (55799)	7175 (3255)
Z-Z	K7	80500 (36515)	105000 (47628)	6984 (3168)

¹ Refrigerant charge quantity and weights will vary based on tube count.

TABLE 23 - APPROXIMATE UNIT WEIGHT INCLUDING MOTOR FOR HYBRID FALLING FILM EVAPORATOR UNITS

SHELLS	COMPRESSOR	SHIPPING WEIGHT LBS. (KGS.)	OPERATING WEIGHT LBS. (KGS.)	EST. REFRIGERANT CHARGE LBS. (KGS.) ¹
A-A	Q3	12850 (5829)	14419 (6540)	695 (315)
C-C	Q3, Q4	14570 (6609)	16848 (7642)	875 (397)
C-C	Q5	15000 (6804)	17278 (7837)	875 (397)
D-D	Q4	17000 (7711)	20051 (9095)	1180 (535)
D-D	Q5	17410 (7897)	20461 (9281)	1180 (535)
E-E	Q5,Q6,Q7,P7	18700 (8482)	21700 (9843)	1120 (508)
F-F	Q5,Q6,Q7,P7	19220 (8718)	23142 (10497)	1415 (642)
G-E	P8, P9	20640 (9362)	24036 (10903)	1320 (599)
H-F	P8, P9	23540 (10678)	28083 (12738)	1775 (805)
I-K	H9	28849 (13086)	34078 (15458)	1820 (826)
K-K	H9	28850 (13086)	34079 (15458)	1820 (826)
I-K	K1	31350 (14220)	35145 (15942)	1820 (826)
M-M	K1,K2	34520 (15658)	46055 (20890)	2300 (1043)
N-N	K1,K2	41273 (18721)	49605 (22501)	2650 (1202)
N-N	K3	48380 (21945)	52905 (23998)	2650 (1202)
P-P	K1,K2	41950 (19028)	51595 (23403)	3100 (1406)
Q-Q	K1,K2	45800 (20775)	56545 (25649)	3500 (1588)
Q-Q	K3	46500 (21092)	59945 (27191)	3500 (1588)

¹ Refrigerant charge quantity and weights will vary based on tube count and configuration. Use for reference only.

Weights (Cont'd)

TABLE 24 - EVAPORATOR MARINE WATERBOX WEIGHTS (LBS.) (TO BE ADDED TO STANDARD UNIT WEIGHTS SHOWN ON TABLE 18 OR 19)

EVAPORATOR CODE	SHIPPING WEIGHT			OPERATING WEIGHT		
	INCREASE - LBS. (KGS.)			INCREASE - LBS. (KGS.)		
	1-PASS	2-PASS	3-PASS	1-PASS	2-PASS	3-PASS
A	924 (419)	744 (337)	978 (444)	1468 (666)	1288 (584)	1522 (690)
C,D	1352 (613)	1114 (505)	1480 (671)	2224 (1009)	1986 (901)	2352 (1067)
E,F	1878 (852)	1260 (572)	2080 (943)	3378 (1532)	2760 (1252)	3580 (1624)
G,H	1213 (550)	1296 (588)	1293 (587)	2655 (1204)	2738 (1242)	2735 (1241)
I,J,K,L	1751 (794)	1843 (836)	1856 (842)	3864 (1753)	3956 (1794)	3969 (1800)
M,N	4290 (1946)	2036 (924)	4140 (1878)	7535 (3418)	3264 (1481)	6300 (2858)
P,Q	4662 (2115)	2250 (1021)	4646 (2107)	7746 (3514)	3486 (1581)	7392 (3353)
R,S,W	4804 (2179)	2700 (1225)	4912 (2228)	8522 (3866)	4516 (2048)	8187 (3714)
X,Z	7088 (3215)	3660 (1660)	7244 (3286)	11552 (5240)	5507 (2498)	11243 (5100)

TABLE 25 - CONDENSER MARINE WATERBOX WEIGHTS (LBS.) (TO BE ADDED TO STANDARD UNIT WEIGHTS SHOWN ON TABLE 18 OR 19)

CONDENSER CODE	SHIPPING WEIGHT			OPERATING WEIGHT		
	INCREASE - KGS.			INCREASE - KGS.		
	1-PASS	2-PASS	3-PASS	1-PASS	2-PASS	3-PASS
A	762 (346)	566 (257)	810 (367)	1274 (578)	1078 (489)	1322 (600)
B	1569 (712)	874 (396)	1677 (761)	2113 (958)	1094 (496)	2071 (939)
C,D	946 (429)	778 (353)	1046 (474)	1692 (767)	1524 (691)	1792 (813)
E,F	726 (329)	811 (368)	791 (359)	1337 (606)	1722 (781)	1702 (772)
I	2066 (937)	1070 (485)	2032 (922)	3017 (1369)	1416 (642)	2738 (1242)
J,K,L	1029 (467)	1167 (529)	1151 (522)	2309 (1047)	2447 (1110)	2431 (1103)
M,N	2466 (1119)	1330 (603)	2324 (1054)	4863 (2206)	2448 (1110)	4582 (2078)
O	2985 (1354)	1443 (655)	2987 (1355)	4435 (2012)	2172 (985)	3979 (1805)
P,Q	3700 (1678)	1858 (843)	3752 (1702)	6561 (2976)	3132 (1421)	5991 (2717)
R,S	3806 (1726)	1946 (883)	3960 (1796)	6657 (3020)	3195 (1449)	6352 (2881)
V,T,W	5196 (2357)	2565 (1163)	5204 (2361)	9161 (4155)	4012 (1820)	8219 (3728)
U	3641 (1652)	1893 (859)	3609 (1637)	5350 (2427)	2556 (1159)	4770 (2164)
X,Z	5840 (2649)	2953 (1339)	5380 (2440)	9900 (4491)	4649 (2109)	8100 (3674)
Y	9094 (4125)	4762 (2160)	9058 (4109)	13326 (6045)	6524 (2959)	12049 (5465)

Guide Specifications

GENERAL

Furnish and install where indicated on the drawings ____ YORK YK Centrifugal Liquid Chilling Unit(s). Each unit shall produce a capacity ____ tons, cooling ____ GPM of ____ from ____ °F to ____ °F when supplied with ____ GPM of condenser water at ____ °F. Power input shall not exceed ____ kW with an IPLV (NPLV) of ____ . The evaporator shall be selected for a ____ fouling factor and a maximum liquid pressure drop of ____ ft. The water-side shall be designed for 150 psig working pressure. The condenser shall be selected for ____ fouling factor and maximum liquid pressure drop of ____ ft. The waterside shall be designed for 150 psig working pressure. Power shall be supplied to the compressor motor at ____ volts- 3 phase-60 Hertz and controls at 115 volts -1-phase-60 Hertz.

Or

Furnish and install where indicated on the drawings ____

YORK YK Centrifugal Liquid Chilling Unit(s). Each unit shall produce a capacity of ____ kW, cooling

____ l/s of ____ from ____ °C to ____ °C when supplied with ____ l/s of condenser water at ____ °C. Power input shall not exceed ____ kW with an IPLV (NPLV) of ____ . The evaporator shall be selected for ____ m² C/W fouling factor and maximum liquid pressure drop of ____ kPa. The waterside shall be designed for 10.3 barg working pressure. The condenser shall be selected for ____ fouling factor and maximum liquid pressure drop of ____ kPa. The waterside shall be designed for 10.3 barg working pressure. Power shall be supplied to the compressor motor at ____ volts - 3-phase-50 Hertz and controls at 115 volts -1-phase-50 Hertz.

Or

FOR DOUBLE BUNDLE HEAT RECOVERY UNIT:

In cooling mode, each unit shall produce a capacity of ____ tons, cooling ____ gpm of ____ from ____ °F to ____ °F when supplied with ____ gpm of condenser water at ____ °F. Power input shall not exceed ____ KW with an NPLV of ____ . The cooler shall be selected for ____ fouling factor and a maximum liquid pressure drop of ____ ft. The waterside shall be designed for ____ psig working pressure. The condenser shall be selected for ____ fouling factor and maximum liquid pressure drop of ____ ft. Tower condenser bundle water side shall be designed for ____ psig working pressure.

In heating mode, each unit shall produce a capacity of ____ tons, cooling ____ gpm of ____ from ____ to ____ °F while providing heating through the heat recovery bundle of ____ gpm of ____ from ____ °F to ____ °F . Power input shall not exceed ____ kW. The heat recovery bundle shall be selected for ____ fouling factor and maximum liquid pressure drop of ____ ft. Heating condenser bundle water side shall be designed for ____ psig working pressure.

Power shall be supplied to the compressor motor at ____ volts – __ phase - __ Hertz and controls at ____ volts – __ - phase - __ Hertz.

Guide Specifications (Cont'd)

Or

In cooling mode, each unit shall produce a capacity of ___ kW, cooling ___ l/s of ___ from ___ °C to ___ °C when supplied with ___ l/s of condenser water at ___ °C. Power input shall not exceed ___ kW with an NPLV of _____. The cooler shall be selected for _____ fouling factor and a maximum liquid pressure drop of _____ kPa. The waterside shall be designed for ___ barg working pressure. The condenser shall be selected for _____ fouling factor and maximum liquid pressure drop of _____ kPa. Tower condenser bundle waterside shall be designed for ___ barg working pressure.

In heating mode, each unit shall produce a capacity of ___ tons, cooling ___ l/s of _____ from _____ to _____ °C while providing heating through the heat recovery bundle of _____ l/s of _____ from _____ °C to _____ °C . Power input shall not exceed ___ kW. The heat recovery bundle shall be selected for _____ fouling factor and maximum liquid pressure drop of ___ kPa. The heating condenser bundle water side shall be designed for ___ barg working pressure.

Power shall be supplied to the compressor motor at ___ volts – ___ phase - ___ Hertz and controls at ___ volts – ___ - phase - ___ Hertz.

Performance shall be certified or rated in accordance with the latest edition of AHRI Standard 550/590 as applicable. Only chillers that are listed in the AHRI Certification Program for Water Chilling Packages Using the Vapor Compression Cycle are acceptable.

Each unit shall be completely factory packaged including evaporator, condenser, sub cooler, compressor, open motor, lubrication system, OptiView Control Center, Variable Speed Drive or Solid-State Starter, and all interconnecting unit piping and wiring. The chiller shall be painted prior to shipment.

The initial charge of oil and refrigerant shall be supplied factory charged in the chiller or shipped in containers and cylinders for field installation.

COMPRESSOR

The compressor shall be a single stage centrifugal type powered by an open drive electric motor. The housing shall be fully accessible with vertical circular joints, with the complete operating assembly removable from the compressor and scroll housing. Compressor castings shall be designed for a minimum 235 psig (16.2 barg) working pressure and hydrostatically pressure tested at a minimum of 352 psig (24.3 barg). The rotor assembly shall consist of a heat treated steel alloy drive shaft and impeller shaft with cast aluminum, fully shrouded impeller. The impeller shall be designed for balanced thrust, dynamically balanced and overspeed tested for smooth, vibration free operation. Insert type journal and thrust bearings shall be fabricated of aluminum alloy, precision bored and axially grooved.

Internal single helical gears with crowned teeth shall be designed so that more than one tooth is in contact at all times to provide even load distribution and quiet operation. Each gear shall be individually mounted in its own journal and thrust bearings to isolate it from impeller and motor forces. Shaft seal shall be provided as a double bellows, double-seal, cartridge type. A gravity-fed oil reservoir shall be built into the top of the compressor to provide lubrication during coastdown in the event of a power failure.

(Fixed Speed Drive) Capacity control shall be achieved by use of pre-rotation vanes to provide fully modulating control from full load to minimum load. (Variable Speed Drive)

Guide Specifications (Cont'd)

Capacity control shall be accomplished by the Adaptive Capacity Control (ACC), providing optimal relationship between compressor speed and inlet pre-rotation vane position for maximum energy efficiency. Control shall automatically compensate for adverse operating conditions, such as fouled tubes, and adjust to prior operation after correction of these conditions.

The unit shall be capable of continuous, reliable operation with low ECWT at all load conditions as outlined on the equipment schedule. An external electric actuator shall automatically control pre-rotation vane position.

LUBRICATION SYSTEM

Lubrication oil shall be force-fed to all compressor bearings, gears, and rotating surfaces by an external variable speed oil pump. The oil pump shall vary oil flow to the compressor based on operating and stand-by conditions, ensuring adequate lubrication at all times. The oil pump shall operate prior to start-up, during compressor operation and during coastdown. Compressor shall have an auxiliary reservoir to provide lubrication during coastdown in the event of a power failure.

An oil reservoir, separate from the compressor, shall contain the submersible 2 HP oil pump and a 3000 watt oil heater, thermostatically controlled to remove refrigerant from the oil. The oil reservoir shall be listed as part of the chiller by a nationally recognized testing laboratory and shall be factory air strength tested at 1.1 times design working pressure.

Oil shall be filtered by an externally-mounted 1/2 micron replaceable cartridge oil filter equipped with service valves. Oil cooling shall be done via refrigerant cooled oil cooler, with all piping factory-installed. Oil side of the oil cooler shall be provided with service valves. An automatic oil return system to recover any oil that may have migrated to the evaporator shall be provided. Oil piping shall be completely factory-installed and tested.

WATER-COOLED OIL COOLER

Optional condenser water-cooled oil cooler is offered for units with Q3 compressors only. The four tube pass and one shell pass oil cooler is by API Basco, Model 05036 (shell diameter 5" OD, tube length 36"). The shell is steel pipe or tubing and tube sheets are steel to ASME specification. Baffles are precision hot-rolled, punched, carbon steel to assure effective circulation by providing minimum clearances between the tubes and tube holes. The cooler is a straight-tube type and has 180 plain copper tubes of 1/4" OD with 24 BWG.

The heat exchanger has either cast iron bonnets to be used for 150 psig (10.3 barg) condenser waterboxes or carbon steel bonnets to be used for 300 psig (20.6 barg) condenser waterboxes. Condenser water is the cooling medium and water circulation is obtained by the water pressure drop across the condenser shell. The minimum requirement of 7 to 8 gpm (0.4 to 0.5 l/s) water for this oil cooler is provided at a pressure drop as low as 3ft with the Q3 piping arrangement.

MOTOR DRIVELINE

The compressor motor shall be an open drip proof, squirrel cage, induction type operating at 3570 rpm for 60Hz operation and 2975 rpm for 50 Hz operation.

The open motor shall be provided with a D-flange. The D-flange is bolted to a cast iron adaptor mounted on the compressor. This allows the motor to be rigidly coupled to the

Guide Specifications (Cont'd)

compressor to provide factory alignment of motor and compressor shafts.

The motor drive shaft shall be directly connected to the compressor shaft with a flexible disc coupling. Coupling shall have all metal construction with no wearing parts to assure long life, and no lubrication requirements to provide low maintenance. For units utilizing remote electro-mechanical starters, a large steel terminal box with gasketed front access cover shall be provided for field-connected conduit.

Overload/overcurrent transformers shall be furnished with all units. (For units furnished with factory-packaged Solid-State Starters or Variable Speed Drive, refer to the "Options" section.)

EVAPORATOR

Evaporator shall be a shell and tube type, hybrid falling film (evaporator codes A_ to Q_) or flooded type (evaporator codes R_ to Z_) designed for a minimum of 180 psig (12.4 barg) on H & K compressor models, 235 psig (16.2 barg) on P & Q compressor models; working pressure on the refrigerant side. Shell shall be fabricated from rolled carbon steel plates with fusion welded seams, carbon steel tube sheets, drilled and reamed to accommodate the tubes, and intermediate tube supports spaced no more than four feet apart. The refrigerant side of each shell is designed, tested and stamped in accordance with ASME Boiler and Pressure Vessel Code, Section VIII - Division 1, or other pressure vessel code as appropriate.

Heat exchanger tubes shall be high-efficiency, externally and internally enhanced type. Tubes shall utilize the "skip-fin" design, providing a smooth internal and external surface at each intermediate tube support. This provides extra wall thickness and non-work hardened copper at the support location, extending the life of the heat exchangers. If skip-fin tubes are not used, minimum tube wall thickness shall be 0.035" (~1 mm). Each tube shall be roller expanded into the tube sheets providing a leak-proof seal, and be individually replaceable. Water velocity through the tubes shall not exceed 12 ft. /sec. (3.7 m/sec). A liquid level sight glass shall be provided on the side of the shell to aid in determining proper refrigerant charge and to check condition of the refrigerant charge. The hybrid falling film evaporator design has suction baffles around the sides and above the falling film section to prevent liquid refrigerant carryover into the compressor. Flooded evaporator designs have a suction baffle on M shells with H9 compressors and an aluminum mesh eliminator on K - Z shells with K compressors located above the tube bundle to prevent liquid refrigerant carryover into the compressor. The evaporator shall have a refrigerant relief device sized to meet the requirements of the ASHRAE 15 Safety Code for Mechanical Refrigeration.

Waterboxes shall be removable to permit tube cleaning and replacement. Stub-out water connections having ANSI/AWWA C-606 grooves to ANSI/AWWA C-606 Standard for Grooved End Shoulder Joints shall be provided. Waterboxes shall be designed for 150 psig (10.3 barg) design working pressure and be tested at 225 psig (15.5 barg). Vent and drain connections with plugs shall be provided on each waterbox. Low flow protection shall be provided by a thermal-type water flow sensor, factory mounted in the water nozzle connection and wired to the chiller control panel.

CONDENSER

Condenser shall be of the shell-and-tube type, designed for a minimum of 235 psig (16.2 barg) working pressure on the refrigerant side. Shell shall be fabricated from rolled carbon

Guide Specifications (Cont'd)

steel plates with fusion-welded seams. Carbon steel tube sheets, drilled and reamed to accommodate the tubes, are welded to the end of each shell. Intermediate tube supports, fabricated from carbon steel plates, are drilled and reamed to eliminate sharp edges. The refrigerant side of each shell is designed, tested and stamped in accordance with ASME Boiler and Pressure Vessel Code, Section VIII – Division I, or other pressure vessel code as appropriate.

Heat exchanger tubes shall be high efficiency, externally and internally enhanced type. Tubes shall utilize the “skip-fin” design, providing a smooth internal and external surface at each intermediate tube support. This provides extra wall thickness and non work-hardened copper at the support location, extending the life of the heat exchangers. If skip-fin tubes are not used, minimum tube wall thickness shall be 0.035" (~1 mm). Each tube shall be roller expanded into the tube sheets providing a leak-proof seal, and be individually replaceable. Water velocity through the tubes shall not exceed 12 ft. /sec. (3.7 m/sec). A liquid level sight glass shall be provided on the side of the shell to aid in determining proper refrigerant charge and to check condition of the refrigerant charge.

The condenser shall have dual refrigerant relief devices; each sized to meet the requirements of the ASHRAE 15 Safety Code for Mechanical Refrigeration. Arrangement shall allow either valve to be isolated and replaced without removing the unit refrigerant charge.

(Option) The condenser shall be provided with positive shutoff valves in the compressor discharge line to the condenser and in the liquid line leaving the condenser. This will allow pumpdown and storage of the refrigerant charge in the condenser. Due to the possibility of not seating properly, check valves are not acceptable for isolation purposes. If a check valve is used, a positive shutoff valve must be provided in series with the check valve.

Waterboxes shall be removable to permit tube cleaning and replacement. Stubout water connections having ANSI/AWWA C-606 grooves shall be provided. Waterboxes shall be designed for 150 psig (10.3 barg) design working pressure and be tested at 225 psig (15.5 barg). Vent and drain connections with plugs shall be provided on each waterbox.

REFRIGERANT FLOW CONTROL

Refrigerant flow to the evaporator shall be controlled by a variable orifice. The variable orifice control shall automatically adjust to maintain proper refrigerant level in the condenser and evaporator. This shall be controlled by monitoring the refrigerant liquid level in the condenser, assuring optimal subcooler performance.

OPTIVIEW CONTROL CENTER

General – The chiller shall be controlled by a stand-alone, microprocessor based control center. The chiller control panel shall provide control of chiller operation and monitoring of chiller sensors, actuators, relays and switches.

Control Panel – The control panel shall include a 10.4-in. (264 mm) diagonal color liquid crystal display (LCD) surrounded by “soft” keys which are redefined based on the screen displayed at that time. This shall be mounted in the middle of a keypad interface and installed in a locked enclosure. The screen shall detail all operations and parameters, using a graphical representation of the chiller and its major components. The panel verbiage is available in eight languages as standard and can be changed on the fly without having to turn off the chiller. Data shall be displayed in either English or Metric units. Smart Freeze Point Protection shall run the chiller at 36°F (2°C) leaving chilled water temperature, and not have nuisance trips on low water temperature. The sophisticated program and sensor

Guide Specifications (Cont'd)

shall monitor the chiller water temperature to prevent freeze-up. When needed, Hot Gas Bypass is available as an option.

The panel shall display countdown timer messages so the operator knows when functions are starting and stopping. Every programmable point shall have a pop-up screen with the allowable ranges, so that the chiller cannot be programmed to operate outside of its design limits.

The chiller control panel shall also provide:

A. System operating information including:

1. Return and leaving chilled water temperature
2. Return and leaving condenser water temperature
3. Evaporator and condenser saturation temperature
4. Differential oil pressure
5. Percent motor current
6. Compressor discharge temperature
7. Oil reservoir temperature
8. Compressor thrust bearing positioning and oil temperature
9. Operating hours
10. Number of unit starts

B. Digital programming of setpoints through the universal keypad including:

1. Leaving chilled water temperature
2. Percent current limit
3. Pull-down demand limiting
4. Six-week schedule for starting and stopping the chiller, pumps and tower
5. Remote reset temperature range

C. Status messages indicating:

1. System ready to start
2. System running
3. System coastdown
4. System safety shutdown – manual restart
5. System cycling shutdown – auto restart
6. System pre-lube
7. Start inhibit

D. The text displayed within the system status and system details field shall be displayed

Guide Specifications (Cont'd)

as a color-coded message to indicate severity: red for safety fault, orange for cycling faults, yellow for warnings, and green for normal messages.

E. Safety shutdowns enunciated through the display and the status bar, and consist of system status, system details, day, time, cause of shutdown, and type of restart required. Safety shutdowns with a fixed speed drive shall include:

1. Evaporator – low pressure
2. Evaporator – transducer or leaving liquid probe
3. Evaporator – transducer or temperature sensor
4. Condenser – high pressure contacts open
5. Condenser – high pressure
6. Condenser – pressure transducer out-of-range
7. Auxiliary safety – contacts closed
8. Discharge – high temperature
9. Discharge – low temperature
10. Oil – high temperature
11. Oil – low differential pressure
12. Oil – high differential pressure
13. Oil – sump pressure transducer out-of-range
14. Oil – differential pressure calibration
15. Oil – variable speed pump – pressure setpoint not achieved
16. Control panel – power failure
17. Motor or starter – current imbalance
18. Thrust bearing – proximity probe clearance (K compressors only)
19. Thrust bearing – proximity probe out-of-range (K compressors only)
20. Thrust bearing – position switch (P, Q & H9 compressors)
21. Watchdog – software reboot

F. Safety shutdowns with a VSD shall include:

1. VSD shutdown – requesting fault data
2. VSD – stop contacts open
3. VSD – 105% motor current overload
4. VSD – high phase A, B, C inverter heat-sink temp.
5. VSD – high converter heat-sink temperature

Guide Specifications (Cont'd)

(Filter Option Only)

6. Harmonic filter – high heat-sink temperature
 7. Harmonic filter – high total demand distribution
- G. Cycling shutdowns enunciated through the display and the status bar, and consists of system status, system details, day, time, cause of shutdown, and type of restart required. Cycling shutdowns with a fixed speed drive shall include:
1. Multi-unit cycling – contacts open
 2. System cycling – contacts open
 3. Oil – low temperature differential
 4. Oil – low temperature
 5. Control panel – power failure
 6. Leaving chilled liquid – low temperature
 7. Leaving chilled liquid – flow switch open
 8. Motor controller – contacts open
 9. Motor controller – loss of current
 10. Power fault
 11. Control panel – schedule
 12. Starter – low supply line voltage (SSS option)
 13. Starter – high supply line voltage (SSS option)
 14. Proximity probe – low supply voltage (K compressors)
 15. Oil – variable speed pump – drive contacts open
- H. Cycling shutdowns with a VSD shall include:
1. VSD shutdown – requesting fault data
 2. VSD – stop contacts open
 3. VSD – initialization failed
 4. VSD – high phase A, B, C instantaneous current
 5. VSD – Phase A, B, C gate driver
 6. VSD – single phase input power
 7. VSD – high DC bus voltage
 8. VSD – pre charge DC bus voltage imbalance
 9. VSD – high internal ambient temperature
 10. VSD – invalid current scale selection

Guide Specifications (Cont'd)

11. VSD – low phase A, B, C inverter heat-sink temp.
12. VSD – low converter heat-sink temperature
13. VSD – pre-charge – low DC bus voltage
14. VSD – logic board processor
15. VSD – run signal
16. VSD – serial communications

(Filter Option Only)

1. Harmonic filter – logic board or communications
 2. Harmonic filter – high DC bus voltage
 3. Harmonic filter – high phase A, B, C current
 4. Harmonic filter – phase locked loop
 5. Harmonic filter – pre-charge – low DC bus voltage
 6. Harmonic filter – DC bus voltage imbalance
 7. Harmonic filter – 110% input current overload
 8. Harmonic filter – logic board power supply
 9. Harmonic filter – run signal
 10. Harmonic filter – DC current transformer
 11. Harmonic filter – DC current transformer
- I. Security access to prevent unauthorized change of setpoints, to allow local or remote control of the chiller, and to allow manual operation of the pre-rotation vanes and oil pump. Access shall be through ID and password recognition, which is defined by three different levels of user competence: view, operator, and service.
- J. Trending data with the ability to customize points of once every second to once every hour. The panel shall trend up to 6 different parameters from a list of over 140, without the need of an external monitoring system.
- K. The operating program stored in non-volatile memory (EPROM) to eliminate re-programming the chiller due to AC power failure or battery discharge. Programmed setpoints shall be retained in lithium battery-backed RTC memory for a minimum of 10 years with power removed from the system.
- L. A fused connection through a transformer in the compressor motor starter to provide individual over-current protected power for all controls.
- M. A numbered terminal strip for all required field interlock wiring.
- N. An RS-232 port to output all system operating data, shutdown/cycling message, and a record of the last 10 cycling or safety shutdowns to a field-supplied printer. Data logs to a printer at a set programmable interval. This data can be preprogrammed to print from 1 minute to 1 day.

Guide Specifications (Cont'd)

- O. The capability to interface with a building automation system via hard-wired connections to each feature to provide:
1. Remote chiller start and stop
 2. Remote leaving chiller liquid temperature adjust
 3. Remote current limit setpoint adjust
 4. Remote ready to start contacts
 5. Safety shutdown contacts
 6. Cycling shutdown contacts
 7. Run contacts

VARIABLE SPEED DRIVE

A variable speed drive shall be factory-installed on the chiller. It shall vary the compressor motor speed by controlling the frequency and voltage of the electrical power to the motor. The adaptive capacity control logic shall automatically adjust motor speed and compressor pre-rotation vane position independently for maximum part load efficiency by analyzing information fed to it by sensors located throughout the chiller.

Drive shall be PWM type utilizing IBPTs with a displacement power factor of 0.95 or better at all loads and speeds.

The variable speed drive shall be unit-mounted in a NEMA- 1 enclosure with all power and control wiring between the drive and chiller factory-installed, including power to the chiller oil pump. Field power wiring shall be a single-point connection and electrical lugs for incoming power wiring shall be provided. The entire chiller package shall be certified to standard UL-1995 by a nationally recognized testing laboratory.

The variable speed drive is cooled by a closed loop, fresh water circuit consisting of a water-to water heat exchanger and circulating pump. All interconnecting water piping is factory installed and rated for 150 psig (10.3 barg) working pressure.

The following features shall be provided: a door interlocked circuit breaker, capable of being padlocked; UL listed ground fault protection; overvoltage and under voltage protection; 3-phase sensing motor overcurrent protection; single phase protection; insensitive to phase rotation; over temperature protection; digital readout at the chiller unit control panel of:

- Output Frequency
- Output Voltage
- 3-phase output current
- Input Kilowatts (kW) and Kilowatt-hours (kWh)
- Self diagnostic service parameters

Separate meters for this information shall not be acceptable.

(Optional) A harmonic filter that limits electrical power supply distortion from the variable speed drive in order to help the building comply with the guidelines of IEEE Std. 519-1992

Guide Specifications (Cont'd)

shall be provided. The filter shall be unit mounted within the same NEMA 1 enclosure and shall be UL listed. The following digital readouts shall be provided at the chiller unit control panel as part of the filter package:

- Input KVA
- Total power-factor
- 3-phase input voltage
- 3-phase input current
- 3-phase input voltage total harmonic distortion (THD)
- 3-phase input current total demand distortion (TDD)
- Self diagnostic service parameters

Separate meters for this information shall not be acceptable.

FACTORY-INSTALLED COMPRESSOR MOTOR STARTER [OPTION THROUGH 900 HP (671 KW) 200 600 VOLTS]

The chiller manufacturer shall furnish a reduced voltage Solid-State Starter for the compressor motor. Starter shall be factory mounted and wired on the chiller. The starter shall provide, through the use of silicon-controlled rectifiers, a smooth acceleration of the motor without current transitions or transients. The starter enclosure shall be NEMA 1, with a hinged access door with lock and key. Electrical lugs for incoming power wiring shall be provided.

Standard Features include: digital readout at the OptiView Control Center of the following:

Display Only

- 3-phase voltage A, B, C
- 3-phase current A, B, C
- Input Power (kW)
- kW Hours
- Starter Model
- Motor Run (LED)
- Motor Current % Full Load Amps
- Current Limit Setpoints
- Pulldown Demand Time Left

Programmable

- Local Motor Current Limit
- Pulldown Demand Limit
- Pulldown Demand Time

Guide Specifications (Cont'd)

Other features include: low line voltage; 115-volt control transformer; three-leg sensing overloads; phase rotation and single-phase failure protection; high temperature safety protection; motor current imbalance and under voltage safeties; open and close SCR protection; momentary power interruption protection. The Solid-State Starter is cooled by a closed loop, fresh water circuit consisting of a water-to-water heat exchanger and circulating pump. All interconnecting water piping is factory-installed and rated for 150 psig (10.3 barg) working pressure.

(Optional) Unit-mounted circuit breaker includes ground fault protection and provides 65,000 amps. Short circuit withstand rating in accordance with UL Standard 508. A non-fused disconnect switch is also available. Both options are lockable.

FACTORY-INSTALLED COMPRESSOR MOTOR STARTER (2300V & 4160V/3/60HZ OR 3300V/3/50HZ- UNIT MOUNTED FOR H9 COMPRESSOR OR LARGER ONLY)

The chiller manufacturer shall furnish a reduced-volt-age, Medium Voltage Solid-State Starter, in accordance with the chiller manufacturer's starter specifications. The starter shall be of modular construction with complete access to all parts. The starter shall be tested and the design starting current and overload settings adjusted at the factory. The starter shall provide, through the use of six in-line (not inside the Delta) silicon controlled rectifiers (2 per phase), a smooth acceleration of the motor without current transitions or transients.

The following protective devices and convenience items shall be factory mounted and wired to the starter:

- A. 3-leg sensing electronic overloads – shuts unit down if current exceeds 105% of FLA to protect the motor windings.
- B. Phase rotation protection circuit – denies start-up when detecting incorrect power wiring phase sequence to the starter which could cause reverse motor rotation and damage the equipment.
- C. Single-phase failure protection circuit – ensures against motor burnout by shutting the unit down if power loss occurs in any of the incoming lines during start-up.
- D. High temperature safety protection system – temperature activated switches on heat sinks will shut the unit down if the SCR temperature exceeds acceptable limits.
- E. 3-phase digital ammeter and digital voltmeter readout via control center – easily cross-check design current and voltage limitations against supply characteristics.
- F. Starter mounted load break rated input disconnect switch with interlocked padlockable handle. Positive disconnecting means shall be visible from outside the enclosure, in operator area. All doors shall be interlocked with the disconnecting means.
- G. Open/Shorted SCR Protection – Failed semiconductor devices are automatically detected and reported via the Control Center.
- H. Power Fault Protection – momentary power interruption protection detects power interruptions within 3 line cycles and interrupts power to the compressor motor within 1 additional line cycle.
- I. Electrical connections – these tin-plated or copper bus bars provide easy connection to incoming copper power lines.

Guide Specifications (Cont'd)

J. Wattmeter – An instantaneous wattmeter tells the customer how much power the chiller is consuming. A kilowatt-hour energy meter is also provided to measure power consumption over a period of time.

K. Shut down History – The Medium Voltage Solid-State Starter shall provide the system control panel with ten histories of previous unit shutdowns initiated by the starter.

In addition, the Starter shall include as standard, the following convenience items already mounted and wired to the starter at the factory:

- Auxiliary control supply transformer – eliminates the need for running separate 115V-1 ph-50/60 Hz power source wiring to the chiller Control Center.

REMOTE ELECTRO MECHANICAL COMPRESSOR MOTOR STARTER (OPTION)

A remote electro mechanical starter of the R-1132 type shall be furnished for each compressor motor. The starter shall be furnished in accordance with the chiller manufacturer's starter specifications and as specified elsewhere in these specifications.

PORTABLE REFRIGERANT STORAGE/RECYCLING SYSTEM

A portable, self-contained refrigerant storage/recycling system shall be provided consisting of a refrigerant compressor with oil separator, storage receiver, water-cooled condenser, filter drier and necessary valves and hoses to remove, replace and distill refrigerant. All necessary controls and safety devices shall be a permanent part of the system.

SI Metric Conversion

Values provided in this manual are in the English inch-pound (I-P) system.

The following factors can be used to convert from English to the most common SI Metric values.

MEASUREMENT	MULTIPLY THIS ENGLISH VALUE	BY	TO OBTAIN THIS METRIC VALUE
CAPACITY	TONS REFRIGERANT EFFECT (ton)	3.516	KILOWATTS (kW)
POWER	KILOWATTS (kW)	NO CHANGE	KILOWATTS (kW)
	HORSEPOWER (hp)	0.7457	KILOWATTS (kW)
FLOW RATE	GALLONS / MINUTE (gpm)	0.0631	LITERS / SECOND (L/s)
LENGTH	FEET (ft)	304.8	MILLIMETERS (mm)
	INCHES (in)	25.4	MILLIMETERS (mm)
WEIGHT	POUNDS (lb)	0.4536	KILOGRAMS (kg)
VELOCITY	FEET / SECOND (fps)	0.3048	METERS / SECOND (m/s)
PRESSURE DROP	FEET OF WATER (ft)	2.989	KILOPASCALS (kPa)
	POUNDS / SQ. INCH (psi)	6.895	KILOPASCALS (k Pa)

TEMPERATURE

To convert degrees Fahrenheit (°F) to degrees Celsius (°C), subtract 32° and multiply by 5/9 or 0.5556.

To convert a temperature range (i.e., 10°F or 12°F chilled water range) from Fahrenheit to Celsius, multiply by 5/9 or 0.5556.

FOULING FACTOR

ENGLISH I-P (ft ² °F hr/Btu)	EQUIVALENT SI METRIC (m ² k/kW)
0.0001	0.018
0.00025	0.044
0.0005	0.088
0.00075	0.132

EFFICIENCY

In the English I-P system, chiller efficiency is measured in kW / ton:

$$\text{kW / ton} = \frac{\text{kW input}}{\text{tons refrigerant effect}}$$

In the SI Metric system, chiller efficiency is measured in Coefficient of Performance (COP).

$$\text{COP} = \frac{\text{kW refrigeration effect}}{\text{kW input}}$$

kW / ton and COP are related as follows:

$$\text{kW/ton} = \frac{3.516}{\text{COP}}$$

$$\text{COP} = \frac{3.516}{\text{kW/ton}}$$

