



CENTRIFUGAL LIQUID CHILLERS

OPERATIONS AND MAINTENANCE

Supersedes: 160.75-O1 (508)

Form 160.75-O1 (211)

MODEL YK (STYLE G) R-134a

WITH OPTIVIEW™ CONTROL CENTER
FOR ELECTRO-MECHANICAL STARTER,
SOLID STATE STARTER AND VARIABLE SPEED DRIVE



LD15222

IMPORTANT!

READ BEFORE PROCEEDING!

GENERAL SAFETY GUIDELINES

This equipment is a relatively complicated apparatus. During installation, operation maintenance or service, individuals may be exposed to certain components or conditions including, but not limited to: refrigerants, materials under pressure, rotating components, and both high and low voltage. Each of these items has the potential, if misused or handled improperly, to cause bodily injury or death. It is the obligation and responsibility of operating/service personnel to identify and recognize these inherent hazards, protect themselves, and proceed safely in completing their tasks. Failure to comply with any of these requirements could result in serious damage to the equipment and the property in

which it is situated, as well as severe personal injury or death to themselves and people at the site.

This document is intended for use by owner-authorized operating/service personnel. It is expected that this individual possesses independent training that will enable them to perform their assigned tasks properly and safely. It is essential that, prior to performing any task on this equipment, this individual shall have read and understood this document and any referenced materials. This individual shall also be familiar with and comply with all applicable governmental standards and regulations pertaining to the task in question.

SAFETY SYMBOLS

The following symbols are used in this document to alert the reader to specific situations:



Indicates a possible hazardous situation which will result in death or serious injury if proper care is not taken.

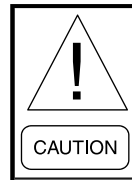

Identifies a hazard which could lead to damage to the machine, damage to other equipment and/or environmental pollution if proper care is not taken or instructions are not followed.



Indicates a potentially hazardous situation which will result in possible injuries or damage to equipment if proper care is not taken.

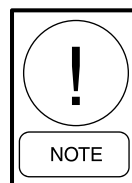

Highlights additional information useful to the technician in completing the work being performed properly.



External wiring, unless specified as an optional connection in the manufacturer's product line, is not to be connected inside the OptiView cabinet. Devices such as relays, switches, transducers and controls and any external wiring must not be installed inside the micro panel. All wiring must be in accordance with Johnson Controls' published specifications and must be performed only by a qualified electrician. Johnson Controls will NOT be responsible for damage/problems resulting from improper connections to the controls or application of improper control signals. Failure to follow this warning will void the manufacturer's warranty and cause serious damage to property or personal injury.

CHANGEABILITY OF THIS DOCUMENT

In complying with Johnson Controls' policy for continuous product improvement, the information contained in this document is subject to change without notice. While Johnson Controls makes no commitment to update or provide current information automatically to the manual owner, that information, if applicable, can be obtained by contacting the nearest Johnson Controls Service office.

Operating/service personnel maintains the responsibility of the applicability of these documents to the competitive equipment the kit is installed on. If there is any question regarding the applicability of these documents, the technician should verify whether the equipment has been modified and if current literature is available with the owner of the equipment prior to performing any work on the chiller.

ASSOCIATED LITERATURE

| MANUAL DESCRIPTION | FORM NUMBER |
|---|-------------|
| Variable Speed Drive – Operation | 160.00-O1 |
| Solid State Starter – Operation and Maintenance | 160.00-O2 |
| Floor Mounted MV SSS – Operation | 160.00-O5 |
| Unit Mounted MV SSS – Operation | 160.00-O7 |
| Installation – Unit | 160.75-N1 |
| Optiview™ Control Center – Operation and Maintenance | 160.54-O1 |
| Wiring Diagram – Field Connections for YK Chiller (Style G) OptiView Control Center with Remote Low or Medium Voltage EMS or Unit Mounted Low or Medium Voltage SSS | 160.75-PW1 |
| Wiring Diagram – Field Connections for YK Chiller (Style G) OptiView Control Center with Remote Medium Voltage SSS | 160.75-PW2 |
| Wiring Diagram – Field Connections for YK Chiller (Style G) OptiView Control Center with Remote Medium Voltage VSD | 160.75-PW3 |
| Wiring Diagram – Field Control Modifications for YK Chiller (Style G) | 160.75-PW4 |
| Wiring Diagram – YK Chiller (Style G) OptiView Control Center with Remote Low or Medium Voltage EMS | 160.75-PW5 |
| Wiring Diagram – YK Chiller (Style G) OptiView Control Center with Unit Mounted Low or Medium Voltage SSS, Unit Mounted Low Voltage VSD with Modbus, or Remote Medium Voltage VSD | 160.75-PW6 |
| Wiring Diagram – YK Chiller (Style G) OptiView Control Center with LTC I/O Board with Remote Low or Medium Voltage EMS | 160.75-PW7 |
| Wiring Diagram – YK Chiller (Style G) OptiView Control Center w/ LTC I/O Board with Unit Mounted Low or Medium Voltage SSS, Unit Mounted Low Voltage VSD with Modbus or Remote Medium Voltage VSD | 160.75-PW8 |
| Renewal Parts – Unit | 160.75-RP1 |
| Renewal Parts – OptiView Control Center | 160.54-RP1 |

NOMENCLATURE

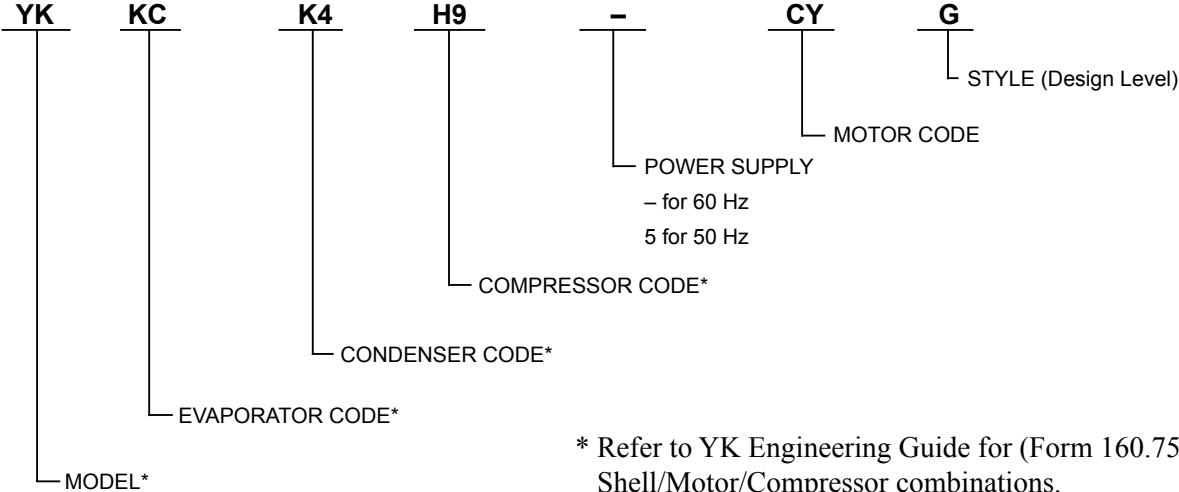

* Refer to YK Engineering Guide for (Form 160.75-EG1) Shell/Motor/Compressor combinations.

TABLE OF CONTENTS

| | |
|--|----|
| SECTION 1 - DESCRIPTION OF SYSTEM AND FUNDAMENTALS OF OPERATION | 7 |
| System Operation Description | 7 |
| Capacity Control | 8 |
| SECTION 2 - SYSTEM OPERATING PROCEDURES | 11 |
| Oil Heaters | 11 |
| Oil Heater Operation | 11 |
| Checking The Oil Level In The Oil Reservoir | 11 |
| Start-Up Procedure | 11 |
| Start-Up | 11 |
| Chiller Operation | 13 |
| Condenser Water Temperature Control | 13 |
| Operating Log Sheet | 13 |
| Operating Inspections | 13 |
| Need For Maintenance Or Service | 15 |
| Stopping The System | 15 |
| Prolonged Shutdown | 15 |
| SECTION 3 - SYSTEM COMPONENTS DESCRIPTION | 17 |
| General | 17 |
| Compressor | 17 |
| Capacity Control | 17 |
| Compressor Lubrication System | 17 |
| Oil Pump | 17 |
| Oil Heater | 21 |
| Motor Driveline | 21 |
| Heat Exchangers | 21 |
| Refrigerant Flow Control | 22 |
| Optional Service Isolation Valves | 22 |
| Optional Hot Gas Bypass | 22 |
| OptiView Control Center | 22 |
| Solid State Starter (Optional) | 22 |
| Variable Speed Drive (Optional) | 22 |
| SECTION 4 - OPERATIONAL MAINTENANCE | 23 |
| Oil Return System | 23 |
| Changing The Dehydrator | 23 |
| The Oil Charge | 24 |
| Oil Charging Procedure | 24 |
| SECTION 5 - TROUBLESHOOTING | 25 |
| SECTION 6 - MAINTENANCE | 27 |
| Renewal Parts | 27 |
| Checking System For Leaks | 27 |
| Conducting R-22 Pressure Test | 27 |
| Vacuum Testing | 28 |
| Vacuum Dehydration | 29 |
| Operation | 29 |
| Refrigerant Charging | 29 |
| Checking The Refrigerant Charge During Unit Shutdown | 30 |
| Handling Refrigerant For Dismantling And Repairs | 30 |

TABLE OF CONTENTS (CONT'D)

Megging The Motor 30
 Compressor 33
 Electrical Controls 34
SECTION 7 - PREVENTIVE MAINTENANCE 35
 Compressor 35
 Compressor Motor 35
 Greased Bearings 35
 Leak Testing 36
 Evaporator And Condenser 36
 Oil Return System 36
 Electrical Controls 36

LIST OF FIGURES

FIGURE 1 - Model YK Chiller 7
FIGURE 2 - Compressor Prerotation Vanes 8
FIGURE 3 - Refrigerant Flow-Thru Chiller (Falling Film Evaporator) 9
FIGURE 4 - Refrigerant Flow-Thru Chiller (Flooded Evaporator) 10
FIGURE 5 - Oil Level Indicator 11
FIGURE 6 - Chiller Starting Sequence And Shutdown Sequence (Em Starter And Solid State Starter) 12
FIGURE 7 - Chiller Starting Sequence And Shutdown Sequence (Variable Speed Drive) 12
FIGURE 8 - Liquid Chiller Log Sheets 14
FIGURE 9 - System Components Front View 18
FIGURE 10 - System Components Rear View 19
FIGURE 11 - Schematic Drawing – (YK) Compressor Lubrication System 20
FIGURE 12 - Oil Return System 23
FIGURE 13 - Charging Oil Reservoir With Oil 24
FIGURE 14 - Evacuation Of Chiller 27
FIGURE 15 - Saturation Curve 29
FIGURE 16 - Diagram, Megging Motor Windings 30
FIGURE 17 - Motor Starter Temperature And Insulation Resistances 31

LIST OF TABLES

TABLE 1 - Operation Analysis Chart 25
TABLE 2 - System Pressures 28
TABLE 3 - Bearing Lubrication 35

SECTION 1 - DESCRIPTION OF SYSTEM AND FUNDAMENTALS OF OPERATION

SYSTEM OPERATION DESCRIPTION

The YORK Model YK Chiller is commonly applied to large air conditioning systems, but may be used on other applications. The chiller consists of an open motor mounted to a compressor (with integral speed increasing gears), condenser, evaporator and variable flow control.

The chiller is controlled by a modern state of the art Microcomputer Control Center that monitors its operation. The Control Center is programmed by the operator to suit job specifications. Automatic timed start-ups and shutdowns are also programmable to suit nighttime, weekends, and holidays. The operating status, temperatures, pressures, and other information perti-

nent to operation of the chiller are automatically displayed and read on a graphic display. Other displays can be observed by pressing the keys as labeled on the Control Center. The chiller with the OptiView Control Center is compatible with an electro-mechanical starter, YORK Solid State Starter (optional), or Variable Speed Drive (optional).

In operation, a liquid (water or brine to be chilled) flows through the evaporator, where boiling refrigerant absorbs heat from the liquid. The chilled liquid is then piped to fan coil units or other air conditioning terminal units, where it flows through finned coils, absorbing heat from the air. The warmed liquid is then returned to the chiller to complete the chilled liquid circuit.

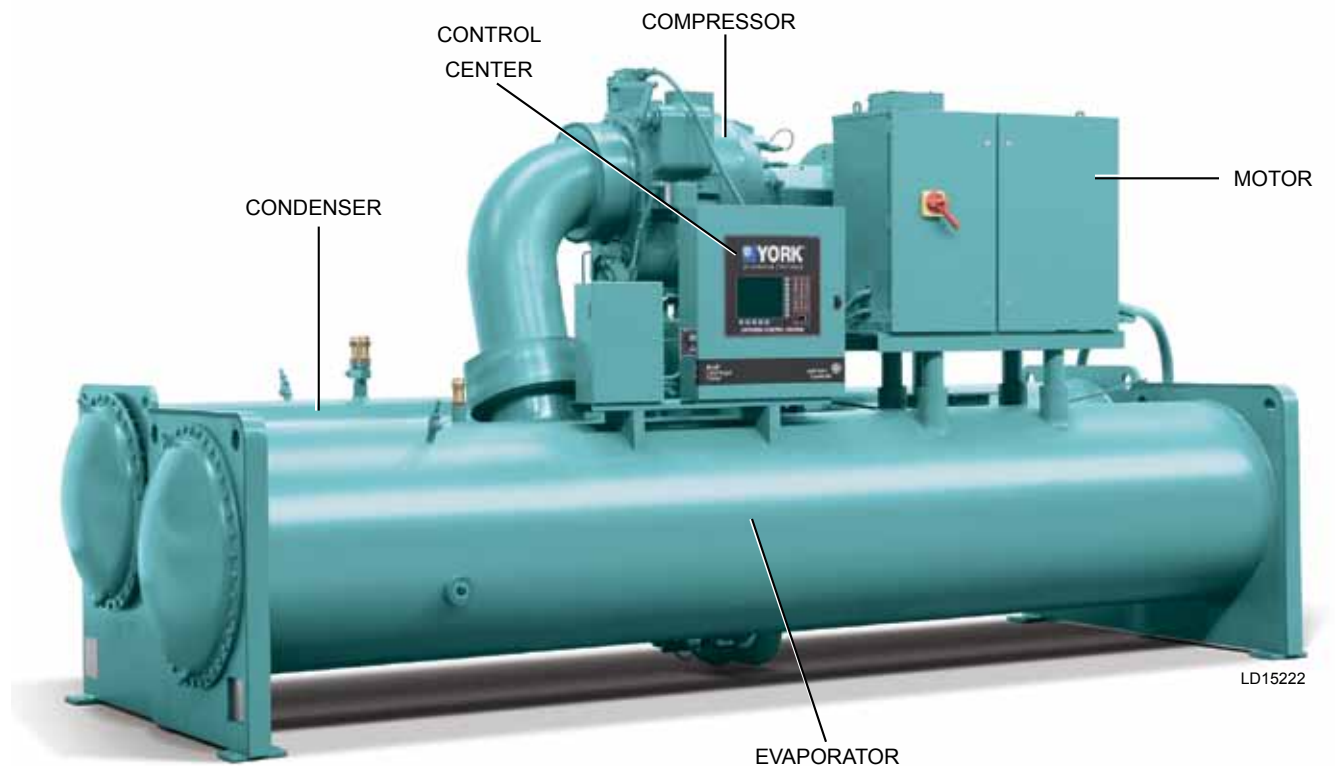
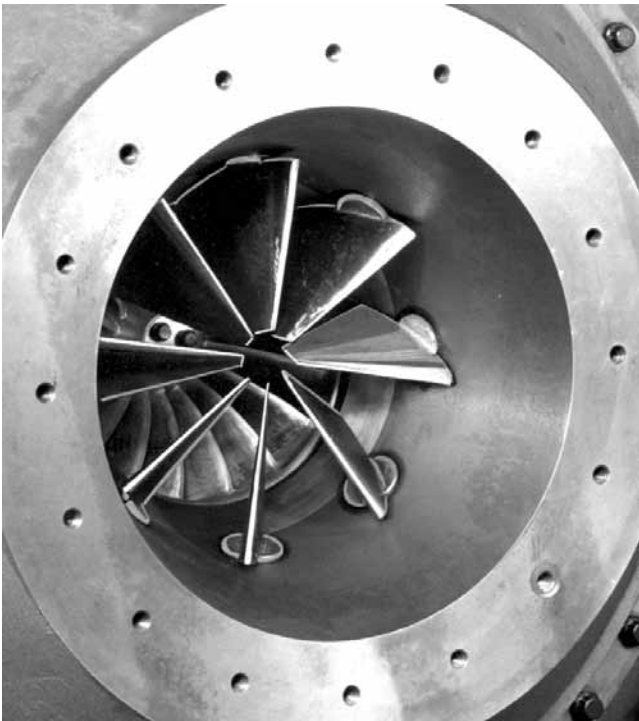

FIGURE 1 - MODEL YK CHILLER



7619A(D)

FIGURE 2 - COMPRESSOR PREROTATION VANES

The refrigerant vapor, which is produced by the boiling action in the evaporator, flows to the compressor where the rotating impeller increases its pressure and temperature and discharges it into the condenser. Water flowing through the condenser tubes absorbs heat

from the refrigerant vapor, causing it to condense. The condenser water is supplied to the chiller from an external source, usually a cooling tower. The condensed refrigerant drains from the condenser into the liquid return line, where the variable orifice meters the flow of liquid refrigerant to the evaporator to complete the refrigerant circuit.





The major components of a chiller are selected to handle the refrigerant, which would be evaporated at full load design conditions. However, most systems will be called upon to deliver full load capacity for only a relatively small part of the time the unit is in operation.

CAPACITY CONTROL

The major components of a chiller are selected for full load capacities, therefore capacity must be controlled to maintain a constant chilled liquid temperature leaving the evaporator. Prerotation vanes (PRV), located at the entrance to the compressor impeller, compensate for variation in load (Refer to *Figure 2 on Page 8*).

The position of these vanes is automatically controlled through a lever arm attached to an electric motor located outside the compressor housing. The automatic adjustment of the vane position in effect provides the performance of many different compressors to match various load conditions from full load with vanes wide open to minimum load with vanes completely closed.

Refrigerant Flow-Thru Chiller (Falling Film Evaporator)

| LEGEND | |
|---|----------------------------------|
|  | High Pressure Vapor |
|  | High Pressure Liquid Refrigerant |
|  | Low Pressure Liquid Refrigerant |
|  | Low Pressure Vapor |

1

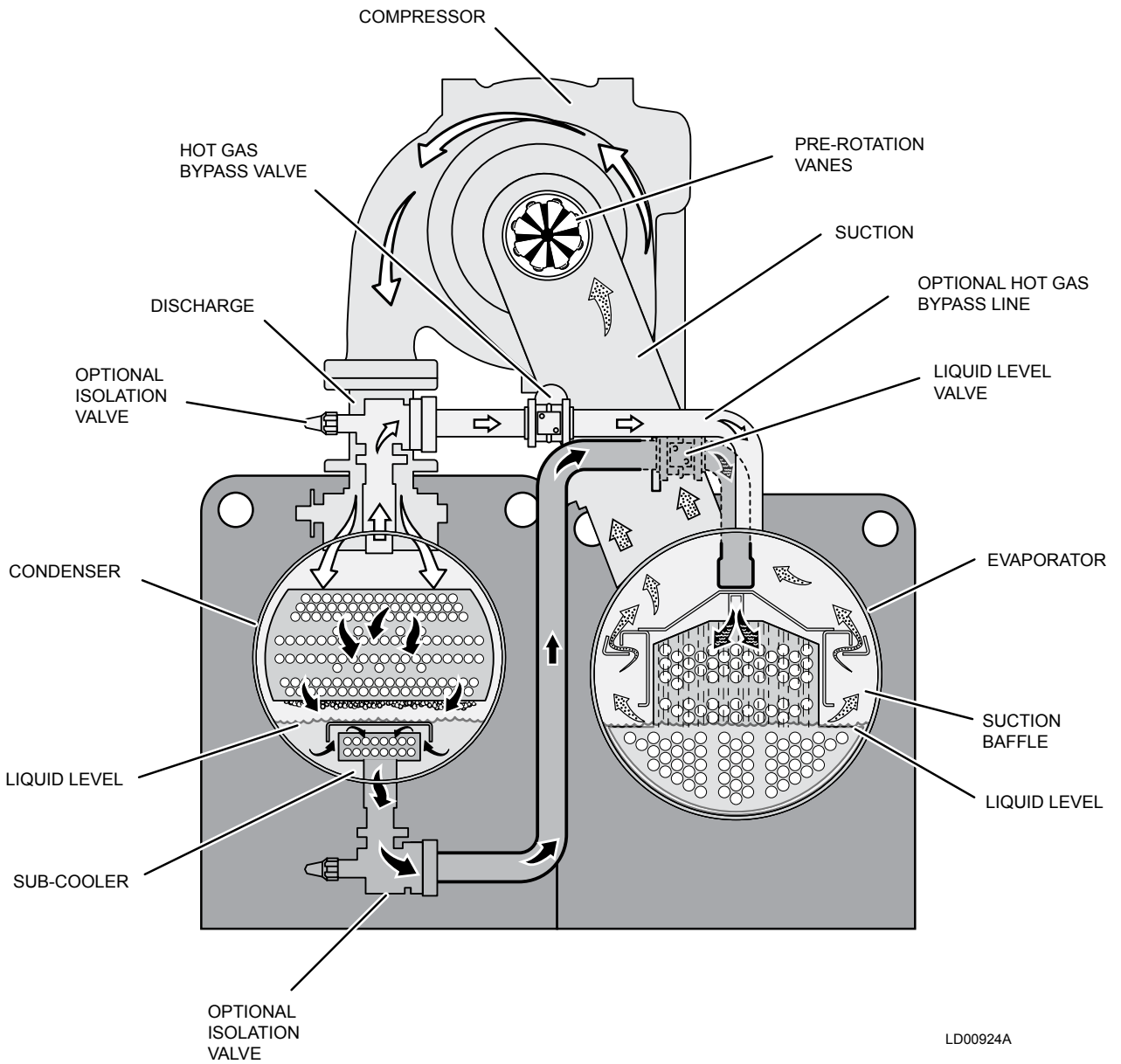

LD00924A

FIGURE 3 - REFRIGERANT FLOW-THRU CHILLER (FALLING FILM EVAPORATOR)

Refrigerant Flow-Thru Chiller (Flooded Evaporator)

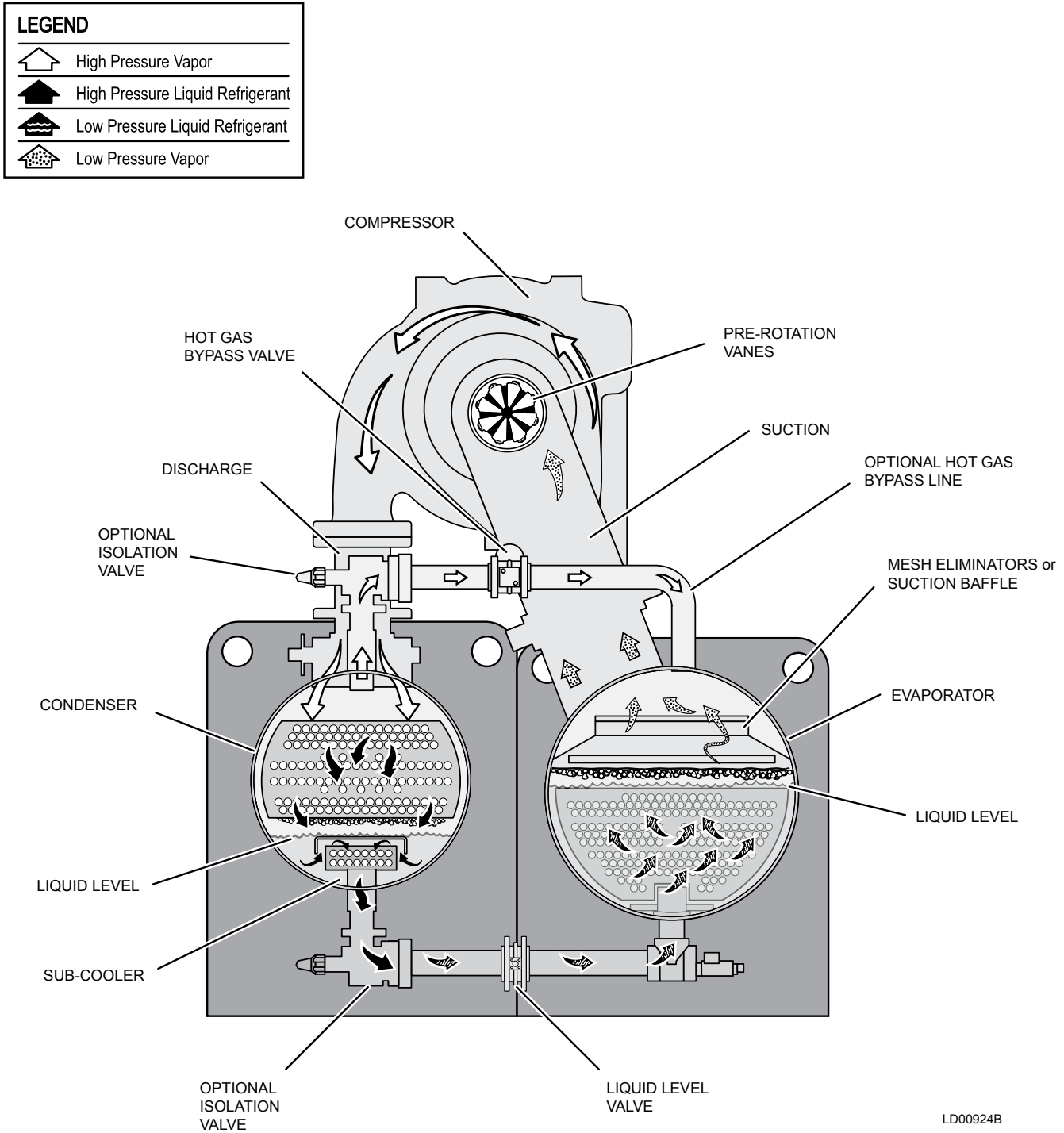

FIGURE 4 - REFRIGERANT FLOW-THRU CHILLER (FLOODED EVAPORATOR)

SECTION 2 - SYSTEM OPERATING PROCEDURES

OIL HEATERS

If the oil heater is de-energized during a shutdown period, it must be energized for 12 hours prior to starting compressor, or remove all oil and recharge compressor with new oil. (Refer to *Oil Charging Procedure on Page 24.*)

OIL HEATER OPERATION

The oil heater operation is controlled by the OptiView™ Control Center. The heater is turned on and off to maintain the oil temperature differential to a value 50°F (27.8°C) above the condenser saturation temperature. This target value is maintained by the control panel.

If the target value is greater than 160°F (71°C), the target defaults to 160°F (71°C). If the target value is less than 110°F (43.3°C), it defaults to 110°F (43.3°C).

To prevent overheating of the oil in the event of a control center component failure, the oil heater thermostat (1HTR) is set to open at 180°F (82°C).

CHECKING THE OIL LEVEL IN THE OIL RESERVOIR

Proper operating oil level – During operation, the oil level should fall to the OPERATING RANGE identified on the vertical oil level indicator label (Refer to *Figure 5 on Page 11*).



LD08647

FIGURE 5 - OIL LEVEL INDICATOR

- If the oil level during operation is in the OVER FULL region of the oil level indicator, oil should be removed from the oil reservoir, This reduces the oil level to the OPERATING RANGE.
- If the oil level during operation is in the LOW OIL region of the oil level indicator, oil should be added to the oil reservoir. (Refer to *Oil Charging Procedure on Page 24.*)



Comply with EPA and local regulations when removing or disposing of refrigeration system oil!

START-UP PROCEDURE

Pre-Starting

Prior to starting the chiller, observe the *Optiview™ Control Center – Operation and Maintenance (Form 160.54-O1)*. Make sure the display reads SYSTEM READY TO START.



Vent any air from the chiller waterboxes prior to starting the water pumps. Failure to do so will result in pass baffle damage.

START-UP

1. If the chilled water pump is manually operated, start the pump. The Control Center will not allow the chiller to start unless chilled liquid flow is established through the unit. If the chilled liquid pump is wired to the Microcomputer Control Center the pump will automatically start, therefore, this step is not necessary.
2. To start the chiller, press the COMPRESSOR START switch. This switch will automatically spring return to the RUN position. (If the unit was previously started, press the STOP/RESET side of the COMPRESSOR switch and then press the START side of the switch to start the chiller.) When the start switch is energized, the Control Center is placed in an operating mode and any malfunction will be noted by messages on a graphic display.

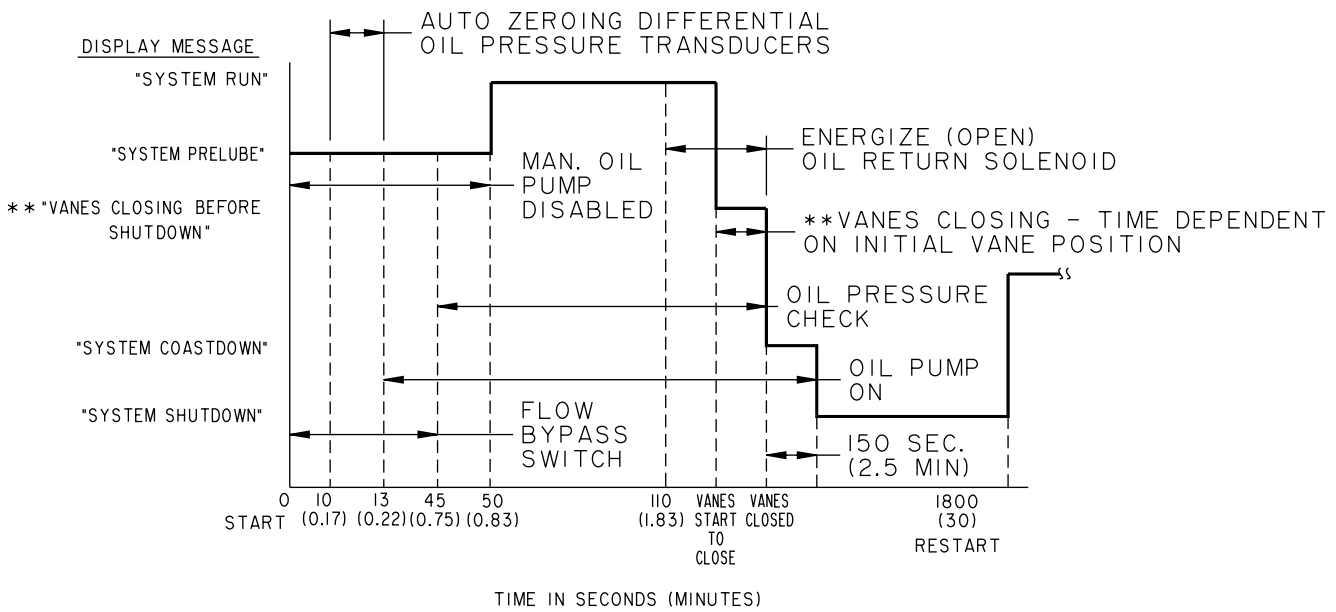

LD15609

** Not for all shutdowns. Refer to "Display Messages" in manual *Optiview™ Control Center – Operation and Maintenance (Form 160.54-01)*.

FIGURE 6 - CHILLER STARTING SEQUENCE AND SHUTDOWN SEQUENCE (EM STARTER AND SOLID STATE STARTER)

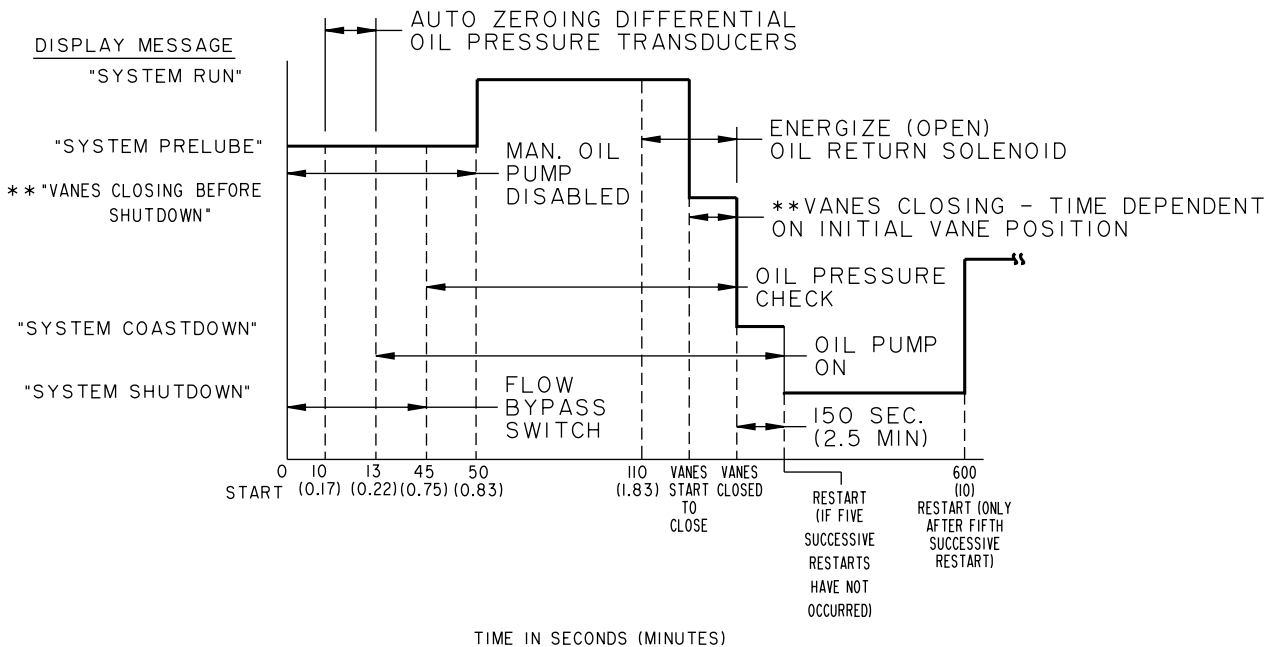

LD15610

** Not for all shutdowns. Refer to "Display Messages" in manual *Optiview™ Control Center – Operation and Maintenance (Form 160.54-01)*.

FIGURE 7 - CHILLER STARTING SEQUENCE AND SHUTDOWN SEQUENCE (VARIABLE SPEED DRIVE)

For display messages and information pertaining to the operation refer to *Optiview™ Control Center – Operation and Maintenance (Form 160.54-01)*.

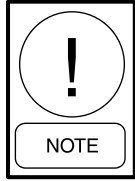

Any malfunctions which occur during STOP/RESET are also displayed.

CHILLER OPERATION

The unit capacity will vary to maintain the leaving CHILLED LIQUID TEMPERATURE setpoint by the Pre-rotation Vanes which are modulated by an actuator under the control of the Microprocessor Board. The vane control routine employs proportional plus derivative (rate) control action. A drop in chilled liquid temperature will cause the actuator to close the Prerotation Vanes to decrease chiller capacity. When the chilled liquid temperature rises, the actuator will open the Prerotation Vanes to increase the capacity of the chiller.

However, the current draw (amperes) by the compressor motor is also limited to FLA setpoint by the microprocessor.

If the load continues to decrease, after the Prerotation Vanes are entirely closed, the chiller will be shut down by the Leaving Chilled Liquid – Low Temperature Control.

CONDENSER WATER TEMPERATURE CONTROL

The YORK chiller is designed to use less power by taking advantage of lower than design temperatures that are naturally produced by cooling towers throughout the operating year. Exact control of condenser water such as a cooling tower bypass, is not necessary for most installations. The minimum entering condenser water temperature for full and part load conditions is specified in the chiller engineering guide.

where:

$$\text{Min. ECWT} = \text{LCWT} - \text{C RANGE} + 5^{\circ}\text{F} + 12 \left(\frac{\% \text{ Load}}{100} \right)$$

$$\text{Min. ECWT} = \text{LCWT} - \text{C RANGE} + 2.8^{\circ}\text{C} + 6.6 \left(\frac{\% \text{ Load}}{100} \right)$$

ECWT = Entering Condensing Water Temperature

LCWT = Leaving Chilled Water Temperature

C Range = Condensing water temperature range at the given load condition.

At start-up, the entering condenser water temperature may be as much as 25°F (14°C) colder than the stand-by return chilled water temperature. Cooling tower fan cycling will normally provide adequate control of the entering condenser water temperature on most installations.

Heat recovery chillers and chillers using optional head pressure control would use a signal provided by the microprocessor to control main condenser bundle heat rejection or pressure, respectively.

OPERATING LOG SHEET

A permanent daily record of system operating conditions (temperatures and pressures) recorded at regular intervals throughout each 24 hour operating period should be kept.

An optional status printer is available for this purpose or *Figure 8 on Page 14* shows a log sheet used by Johnson Controls Personnel for recording test data on chiller systems. It is available from the factory in pads of 50 sheets each under Form 160.44-F7 and may be obtained through the nearest Johnson Controls office. Automatic data logging is possible by connecting the optional printer and programming the DATA LOGGER function.

An accurate record of readings serves as a valuable reference for operating the system. Readings taken when a system is newly installed will establish normal conditions with which to compare later readings.

For example, an increase in condenser approach temperature (condenser temperature minus leaving condenser water temperature) may be an indication of dirty condenser tubes.

OPERATING INSPECTIONS

By following a regular inspection using the display readings of the Microcomputer Control Center, and maintenance procedure, the operator will avoid serious operating difficulty. The following list of inspections and procedures should be used as a guide.

Daily

1. Check OptiView™ Control Center displays.
2. If the compressor is in operation, check the bearing oil pressure on the SYSTEM Screen. Also check the oil level in the oil reservoir. Operating oil level should be operating range of oil indicator. Drain or add oil if necessary.

3. Check entering and leaving condenser water pressure and temperatures for comparison with job design conditions. Condenser water temperatures can be checked on the SYSTEM Screen.
4. Check the entering and leaving chilled liquid temperatures and evaporator pressure for comparison with job design conditions on the SYSTEM Screen.
5. Check the condenser saturation temperature (based upon condenser pressure sensed by the condenser transducer) on the SYSTEM Screen.
6. Check the compressor discharge temperature on the SYSTEM Screen. During normal operation discharge temperature should not exceed 220°F (104°C).
7. Check the compressor motor current on the SYSTEM Screen.
8. Check for any signs of dirty or fouled condenser tubes. (The temperature difference between water leaving condenser and saturated condensing temperature should not exceed the difference recorded for a new unit by more than 4°F (2.2°C)).

Weekly

1. Check the refrigerant charge. (Refer to *Checking The Refrigerant Charge During Unit Shutdown on Page 30.*)

Monthly

1. Leak check the entire chiller.

Quarterly

1. Perform chemical analysis of oil.

Semi-Annually (or more often as required)

1. Change and inspect compressor oil filter element.
2. Oil return system.
 - A. Change dehydrator.
 - B. Check nozzle of eductor for foreign particles.
3. Check controls and safety cutouts.



23889A

***NOTE:** These items can be printed by an electronic printer connected to the Microboard and pressing the **PRINT** key on the Keypad, or automatically using the Data Logger feature.

FIGURE 8 - LIQUID CHILLER LOG SHEETS

Annually (more often if necessary)

1. Drain and replace the oil in the compressor oil sump. (Refer to *Oil Charging Procedure on Page 24.*)
2. Evaporator and Condenser.
 - A. Inspect and clean water strainers.
 - B. Inspect and clean tubes as required.
 - C. Inspect end sheets.
3. Compressor Drive Motor (See motor manufacturers maintenance and service instruction supplied with unit)
 - A. Clean air passages and windings per manufacturers instructions.
 - B. Meg motor windings – Refer to *Figure 16 on Page 30* for details.
 - C. Lubricate per motor manufacturer recommendations.
4. Inspect and service electrical components as necessary.
5. Perform refrigerant analysis.

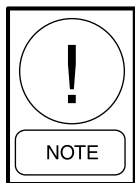

If quarterly inspection indicates oil is fine, replacing the oil is not necessary

NEED FOR MAINTENANCE OR SERVICE

If the system is malfunctioning in any manner or the unit is stopped by one of the safety controls, consult the *Operation Analysis Chart, Table 1 on Page 25* of this manual. After consulting this chart, if you are unable to make the proper repairs or adjustments to start the compressor or the particular trouble continues to hinder the performance of the unit, please call the nearest Johnson Controls District Office. Failure to report constant troubles could damage the unit and increase the cost of repairs.

STOPPING THE SYSTEM

The Optiview™ Control Center can be programmed to start and stop automatically (maximum, once each day) whenever desired. Refer to the *Optiview™ Control Center – Operation and Maintenance (Form 160.54-01)*. To stop the chiller, proceed as follows:

1. Push the soft shutdown key on the homescreen on the OptiView panel or rapid stop with the COMPRESSOR STOP/RESET switch. The compressor will stop automatically. The oil pump will continue to run for coastdown period. The oil pump will then stop automatically.
2. Stop the chilled water pump (if not wired into the Microcomputer Control Center, in which case it will shut off automatically simultaneously with the oil pump.) (The actual water pump contact operation is dependent upon the position of Microboard jumper J54.)
3. Open the switch to the cooling tower fan motors, if used.
4. The compressor sump oil heater is energized when the unit is stopped.

PROLONGED SHUTDOWN

If the chiller is to be shut down for an extended period of time (for example, over the winter season), the following paragraphs outline the procedure to be followed.

1. Test all system joints for refrigerant leaks with a leak detector. If any leaks are found, they should be repaired before allowing the system to stand for a long period of time.

During long idle periods, the tightness of the system should be checked periodically.

2. If freezing temperatures are encountered while the system is idle, carefully drain the cooling water from the cooling tower, condenser, condenser pump, and the chilled water system-chilled water pump and coils.

Open the drains on the evaporator and condenser liquid heads to assure complete drainage. (If a Variable Speed Drive, drain its cooling system. If Solid State Starter equipped drain liquid from starter cooling loop.)
3. If freezing temperatures are encountered for periods longer than a few days, the refrigerant should be recovered to containers to prevent leakage from O-ring joints.
4. On the SETUP Screen, disable the clock. This conserves the battery.
5. Open the main disconnect switches to the compressor motor, condenser water pump and the chilled water pump. Open the 115 volt circuit to the Control Center.

THIS PAGE INTENTIONALLY LEFT BLANK

SECTION 3 - SYSTEM COMPONENTS DESCRIPTION

GENERAL

The YORK Model YK Centrifugal Liquid Chiller is completely factory-packaged including evaporator, condenser, compressor, motor, lubrication system, OptiView Control Center, and all interconnecting unit piping and wiring.

COMPRESSOR

The compressor is a single-stage centrifugal type powered by an open-drive electric motor.

The rotor assembly consists of a heat-treated alloy steel drive shaft and impeller shaft with a cast aluminum, fully shrouded impeller. The impeller is designed for balanced thrust and is dynamically balanced and over-speed tested. The inserted type journal and thrust bearings are fabricated of aluminum alloy. Single helical gears with crowned teeth are designed so that more than one tooth is in contact at all times. Gears are integrally assembled in the compressor rotor support and are film lubricated. Each gear is individually mounted in its own journal and thrust bearings.

The open-drive compressor shaft seal is a double bellows cartridge style with ceramic internal and atmospheric seal faces. The seal is oil-flooded at all times and is pressure-lubricated during operation.

CAPACITY CONTROL

Prerotation vanes (PRV) modulate chiller capacity from 100% to as low as 15% of design for normal air conditioning applications. Operation is by an external, electric PRV actuator which automatically controls the vane position to maintain a constant leaving chilled liquid temperature.

COMPRESSOR LUBRICATION SYSTEM

The chiller lubrication system consists of the oil pump, oil filter, oil cooler and all interconnecting oil piping and passages. There are main points within the compressor which must be supplied with forced lubrication as follows:

1. Compressor Drive Shaft (Low Speed)
 - A. Shaft seal.
 - B. Front and rear journal bearings – one on each side of driving gear.
- C. Low speed thrust bearing (forward and reverse).
2. Compressor Driven Shaft (High Speed)
 - A. Forward and reverse high speed thrust bearing.
 - B. Two journal bearings.
3. Speed Increasing Gears
 - A. Meshing surfaces of drive and pinion gear teeth.

To provide the required amount of oil under the necessary pressure to properly lubricate these parts, a motor driven submersible oil pump is located in a remote oil sump.

Upon pressing of the COMPRESSOR START switch on the Control Center, the oil pump is immediately energized. After a 50 second pre-lube period, the compressor motor will start. The oil pump will continue to run during the entire operation of the compressor, and for 150 seconds during compressor coastdown.

The submerged oil pump takes suction from the surrounding oil and discharges it to the oil cooler where heat is rejected. The oil flows from the oil cooler to the oil filter. The oil leaves the filter and flows to the emergency oil reservoir where it is distributed to the compressor bearings. The oil lubricates the compressor rotating components and is returned to the oil sump.

There is an emergency oil reservoir located at the highest point in the lubrication system internally in the compressor. It provides an oil supply to the various bearings and gears in the event of a system shutdown due to power failure. The reservoir, located on the top of the compressor, allows the oil to be distributed through the passages by gravity flow, thus providing necessary lubrication during the compressor coastdown.

OIL PUMP

For normal operation, the oil pump should operate at all times during chiller operation.

On shutdown of the system for any reason, the oil pump operates and continues to run for 150 seconds. The system cannot restart during that time interval.

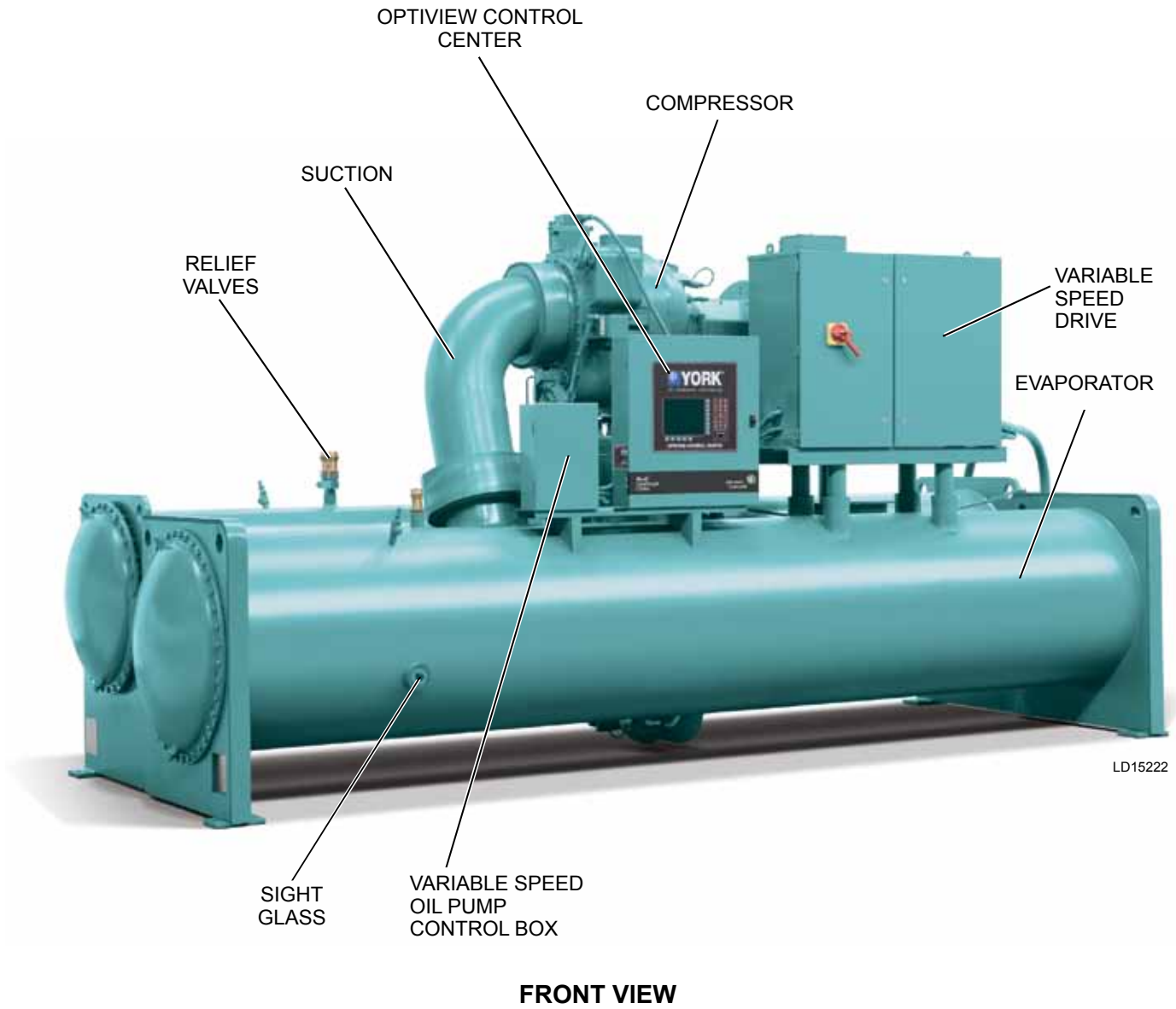
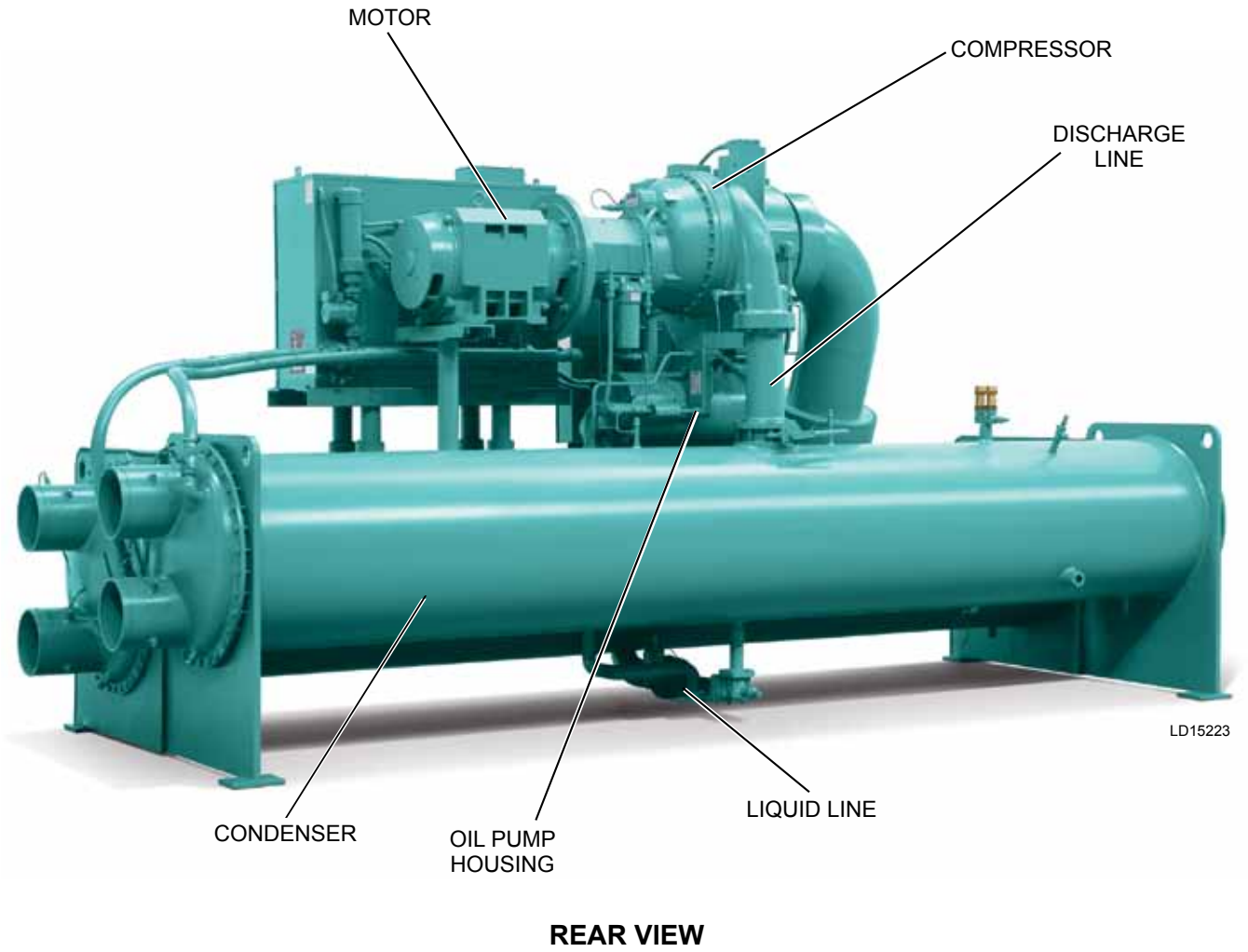
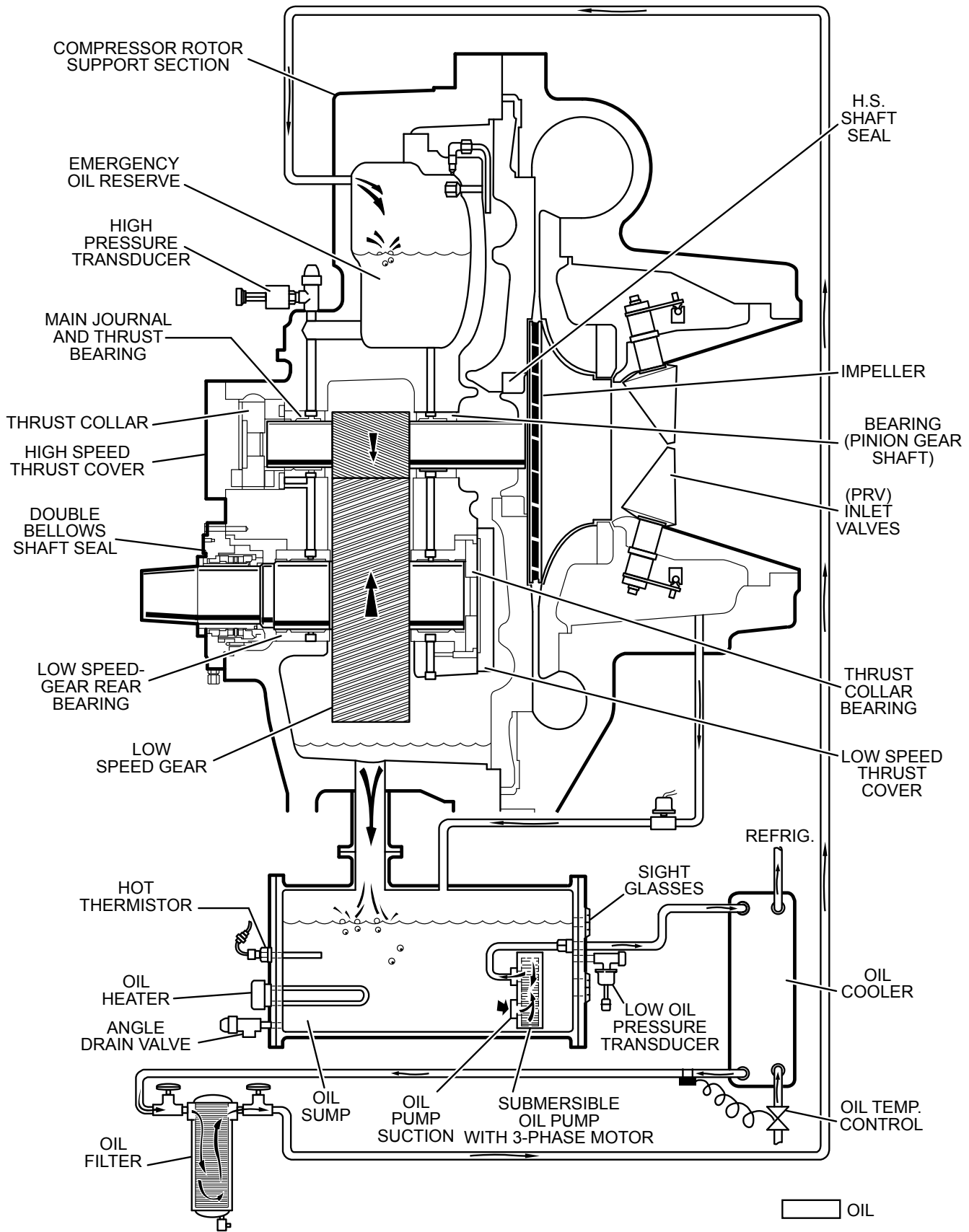

FIGURE 9 - SYSTEM COMPONENTS FRONT VIEW



3

FIGURE 10 - SYSTEM COMPONENTS REAR VIEW



LD15200

FIGURE 11 - SCHEMATIC DRAWING - (YK) COMPRESSOR LUBRICATION SYSTEM

OIL HEATER

During long idle periods, the oil in the compressor oil reservoir tends to absorb as much refrigerant as it can hold, depending upon the temperature of the oil and the pressure in the reservoir. As the oil temperature is lowered, the amount of refrigerant absorbed will be increased. If the quantity of refrigerant in the oil becomes excessive, violent oil foaming will result as the pressure within the system is lowered on starting. This foaming is caused by refrigerant boiling out of the oil as the pressure is lowered. If this foam reaches the oil pump suction, the bearing oil pressure will fluctuate with possible temporary loss of lubrication, causing the oil pressure safety cutout to actuate and stop the system. Refer to *Optiview™ Control Center – Operation and Maintenance (Form 160.54-01)*.

MOTOR DRIVELINE

The compressor motor is an open-drip-proof, squirrel cage, induction type constructed to YORK design specifications. 60 hertz motors operate at 3570 rpm. 50 hertz motors operate at 2975 rpm.

The open motor is provided with a D-flange, cast iron adapter mounted to the compressor and supported by a motor support.

Motor drive shaft is directly connected to the compressor shaft with a flexible disc coupling. This coupling has all metal construction with no wearing parts to assure long life, and no lubrication requirements to provide low maintenance.

For units utilizing remote Electro-Mechanical starters, a terminal box is provided for field connected conduit. Motor terminals are brought through the motor casing into the terminal box. Jumpers are furnished for three-lead type of starting. Motor terminal lugs are not furnished. Overload/over current transformers are furnished with all units.

HEAT EXCHANGERS

Evaporator and condenser shells are fabricated from rolled carbon steel plates with fusion welded seams.

Heat exchanger tubes are internally enhanced type.

The evaporator is a shell and tube type with customer process fluid flowing inside the tubes and refrigerant removing heat on the shell side via evaporation. Evaporator codes A* to K* utilize a hybrid falling film design. It contains a balance of flooded and falling film technology to optimize efficiency, minimize refriger-

ant charge, and maintain reliable control. A specifically designed spray distributor provides uniform distribution of refrigerant over the entire length to yield optimum heat transfer. The hybrid falling film evaporator design has suction baffles around the sides and above the falling film section to prevent liquid refrigerant carryover into the compressor.

Evaporators codes M* thru Z* are flooded type, with a liquid inlet distributor trough underneath the tube bundle which provides uniform distribution of refrigerant over the entire shell length to yield optimum heat transfer. Flooded evaporator designs have a suction baffle on M* shells with H9 compressors and an aluminum mesh eliminator on K* - Z* shells with K compressors located above the tube bundle to prevent liquid refrigerant carryover into the compressor.

A 1-1/2" (38 mm) liquid level sight glass is conveniently located on the side of the shell to aid in determining proper refrigerant charge. The evaporator shell contains a dual refrigerant relief valve arrangement set at 180 psig (12.4 barg) on H and K compressor models; 235 psig (16.2 barg) on P and Q compressor models; or single-relief valve arrangement, if the chiller is supplied with optional refrigerant isolation valves. A 1" (25.4 mm) refrigerant charging valve is provided. The condenser is a shell and tube type, with a discharge gas baffle to prevent direct high velocity impingement on the tubes. The baffle is also used to distribute the refrigerant gas flow properly for most efficient heat transfer. An optional cast steel condenser inlet diffuser may be offered, on "M" and larger condensers, in lieu of the baffle, to provide dynamic pressure recovery and enhanced chiller efficiency. An integral sub-cooler is located at the bottom of the condenser shell providing highly effective liquid refrigerant subcooling to provide the highest cycle efficiency. The condenser contains dual refrigerant relief valves set at 235 psig (16.2 barg).

The removable waterboxes are fabricated of steel. The design working pressure is 150 psig (10.3 barg) and the boxes are tested at 225 psig (15.5 barg). Integral steel water baffles are located and welded within the waterbox to provide the required pass arrangements. Stub-out water nozzle connections with ANSI/AWWA C-606 grooves are welded to the waterboxes. These nozzle connections are suitable for ANSI/AWWA C-606 couplings, welding or flanges, and are capped for shipment. Plugged 3/4" (19 mm) drain and vent connections are provided in each waterbox.

REFRIGERANT FLOW CONTROL

Refrigerant flow to the evaporator is controlled by a variable orifice.

A level sensor senses the refrigerant level in the condenser and outputs an analog voltage to the Microboard that represents this level (0% = empty; 100% = full). Under program control, the Microboard modulates a variable orifice to control the condenser refrigerant level to a programmed setpoint. Other setpoints affect the control sensitivity and response. These setpoints must be entered at chiller commissioning by a qualified service technician. Only a qualified service technician may modify these settings.

While the chiller is shut down, the orifice will be in the fully open position causing the sensed level to be approximately 0%. When the chiller is started, after the vane motor end switch (VMS) opens when entering **SYSTEM RUN**, if actual level is less than the level setpoint, a linearly increasing ramp is applied to the level setpoint. This ramp causes the setpoint to go from the initial refrigerant level (approximately 0%) to the programmed setpoint over a programmable period of time.

If the actual level is greater than the setpoint when the VMS opens, there is no pulldown period, it immediately begins to control to the programmed setpoint.

While the chiller is running, the refrigerant level is normally controlled to the level setpoint. However, anytime the vanes fully close (VMS closes), normal level control is terminated, any refrigerant level setpoint in effect is cancelled and the outputs to the level control will be constant open.

OPTIONAL SERVICE ISOLATION VALVES

If your chiller is equipped with optional service isolation valves on the discharge and liquid line, these valves must remain open during operation. These valves are used for isolating the refrigerant charge in either the evaporator or condenser to allow service access to the system. A refrigerant pump-out unit will be required to isolate the refrigerant.

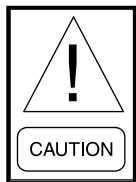

Isolation of the refrigerant in this system must be performed by a qualified service technician.

OPTIONAL HOT GAS BYPASS

Hot gas bypass is optional and is used to eliminate compressor surge during light load or high head operation. The OptiView control panel will automatically modulate the hot gas valve open and closed as required. Adjustment of the hot gas control valve must be performed by a qualified service technician following the Hot Gas Set-up procedure.

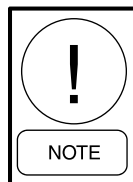

Changes in chilled water flow will require re-adjustment of the hot gas control to insure proper operation.

OPTIVIEW CONTROL CENTER

The OptiView Control Center is factory-mounted, wired and tested. The electronic panel automatically controls the operation of the unit in meeting system cooling requirements while minimizing energy usage. For detailed information on the Control Center, refer to *SECTION 2 - SYSTEM OPERATING PROCEDURES* of this manual.

SOLID STATE STARTER (OPTIONAL)

The Solid State Starter is a reduced voltage starter that controls and maintains a constant current flow to the motor during start-up. It is mounted on the chiller. Power and control wiring between the starter and chiller are factory installed. The starter enclosure is NEMA-1 with a hinged access door with lock and key. Electrical lugs for incoming power wiring are provided.

VARIABLE SPEED DRIVE (OPTIONAL)

A Variable Speed Drive can be factory packaged with the chiller. It is designed to vary the compressor motor speed and prerotation vane position by controlling the frequency and voltage of the electrical power to the motor. Operational information is contained in the *Variable Speed Drive – Operation (Form 160.00-01)*. The control logic automatically adjusts motor speed and compressor prerotation vane position for maximum part load efficiency by analyzing information fed to it by sensors located throughout the chiller.

SECTION 4 - OPERATIONAL MAINTENANCE

OIL RETURN SYSTEM

The oil return system continuously maintains the proper oil level in the compressor oil sump (Refer to *Figure 12 on Page 23*).

High pressure condenser gas flows continuously through the eductor inducing the low pressure, oil rich liquid to flow from the evaporator, through the dehydrator to the compressor sump.

CHANGING THE DEHYDRATOR

To change the dehydrator, use the following procedure:

1. Isolate the dehydrator at the stop valves.
2. Remove the dehydrator (Refer to *Figure 12 on Page 23*).
3. Assemble the new filter-drier.
4. Open evaporator stop valve and check dehydrator connections for refrigerant leaks.
5. Open all the dehydrator stop valves.

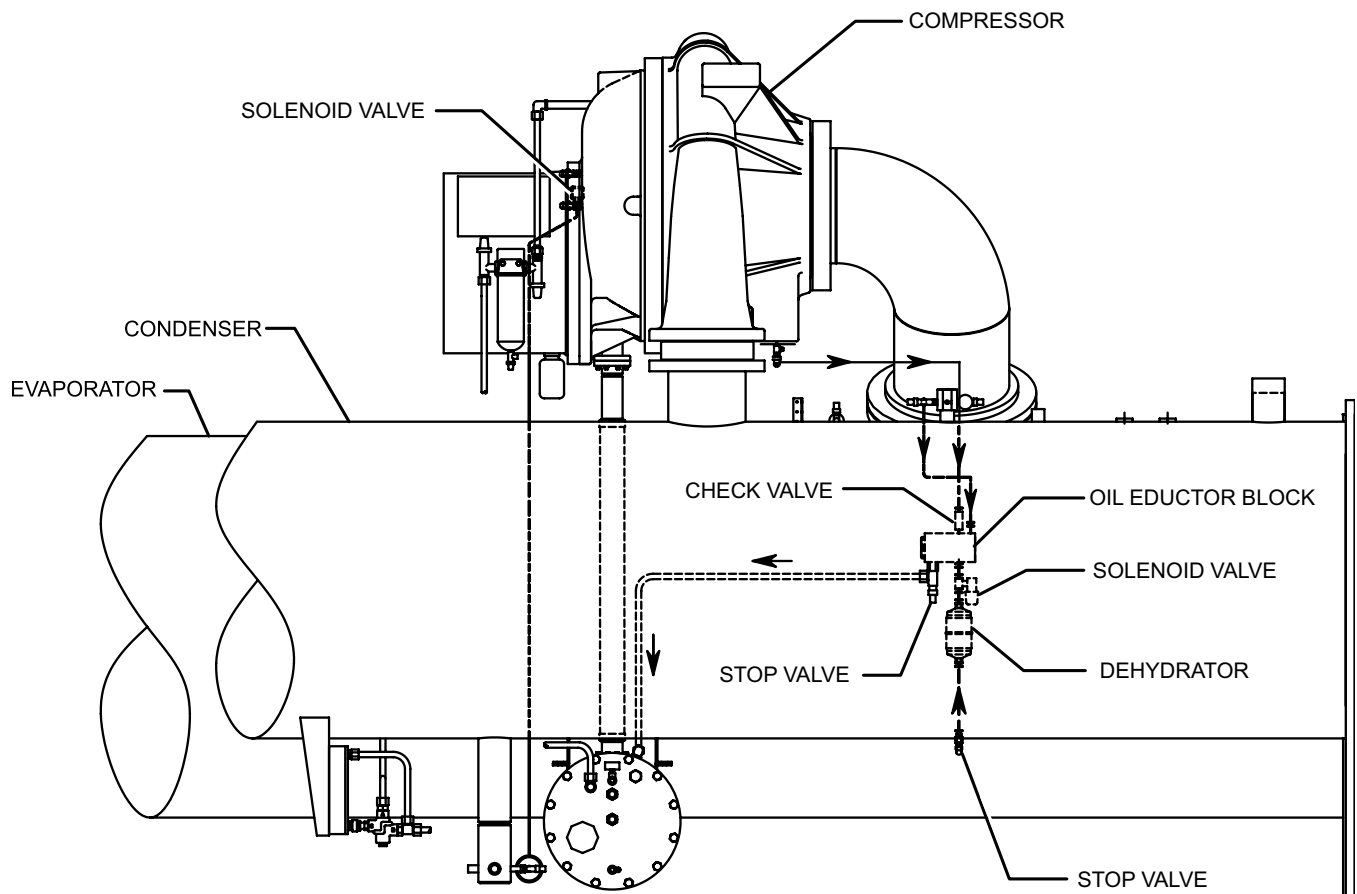

FIGURE 12 - OIL RETURN SYSTEM

LD08578

THE OIL CHARGE

The nominal oil charge for all H, K, and P8-P9 YK compressors is 20 gallons, and for Q3-Q7 YK compressors is 10 gallons of type YORK K or YORK H oil.

New YORK Refrigeration oil must be used in the centrifugal compressor. Since oil absorbs moisture when exposed to the atmosphere, it should be kept tightly capped until used.

OIL CHARGING PROCEDURE

During operation the compressor oil level must be maintained in the OPERATING RANGE identified on the vertical oil level indicator. If the oil level falls into the lower sight glass, it is necessary to add oil to the compressor oil reservoir. The oil should be charged into the oil reservoir using the YORK Oil Charging Pump – YORK Part No. 070-10654. To charge oil into the oil reservoir, proceed as follows:

1. The unit must be shut down.
2. Immerse the suction connection of the oil charging pump in a clean container of new oil and connect the pump discharge connection to the oil charging

valve (A) located on the remote oil reservoir cover plate. (Refer to *Figure 13 on Page 24*) Do not tighten the connection at the charging valve until after the air is forced out by pumping a few strokes of the oil pump. This fills the lines with oil and prevents air from being pumped into the system.

3. Open the oil charging valve and pump oil into the system until oil level in the compressor oil reservoir is in the OVER FULL region of the oil level indicator label. Close the charging valve and disconnect the hand oil pump.
4. As soon as oil charging is complete, close the power supply to the starter to energize the oil heater. This will keep the concentration of refrigerant in the oil to a minimum.

When the oil reservoir is initially charged with oil, the oil pump should be started manually to fill the lines, passages, oil cooler and oil filter. This will lower the oil level in the reservoir. It may then be necessary to add oil to bring the level back into the OPERATING RANGE of the oil level indicator label.

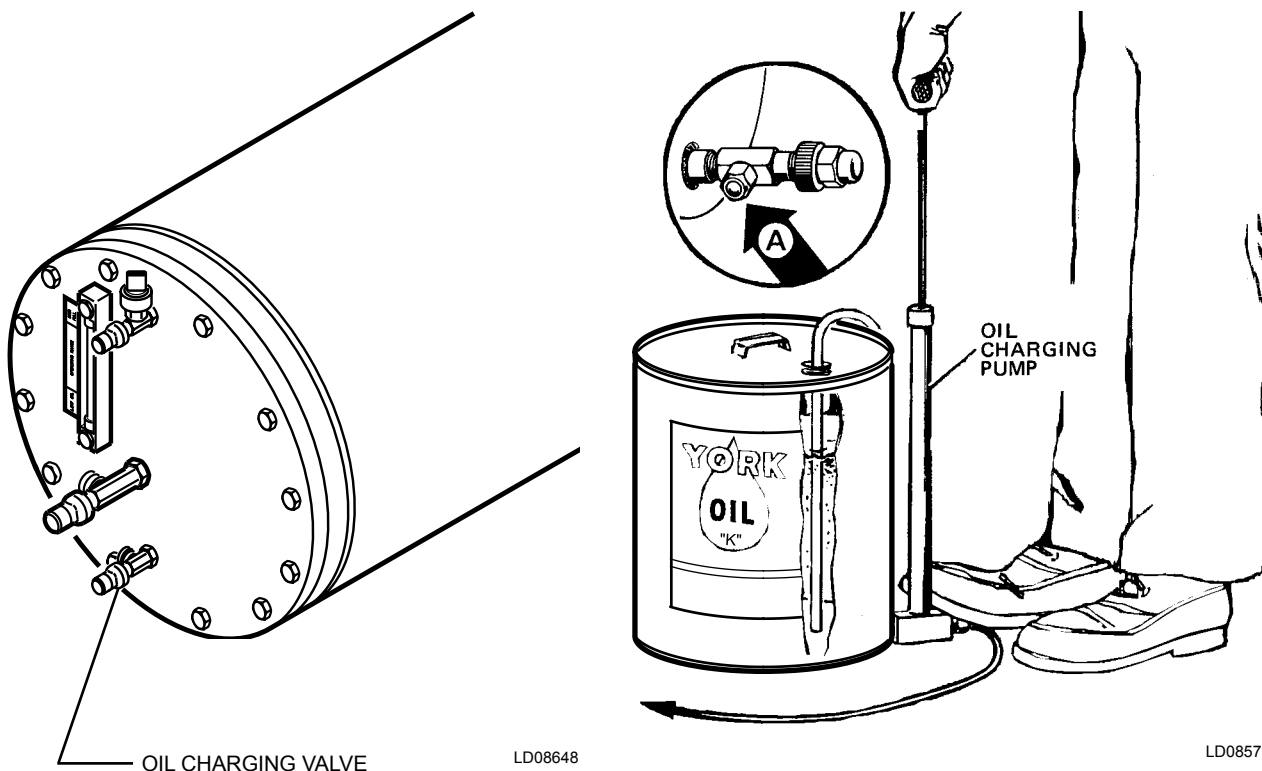



FIGURE 13 - CHARGING OIL RESERVOIR WITH OIL

SECTION 5 - TROUBLESHOOTING

TABLE 1 - OPERATION ANALYSIS CHART

| RESULTS | POSSIBLE CAUSE | REMEDY |
|---|--|---|
| 1. SYMPTOM: ABNORMALLY HIGH DISCHARGE PRESSURE | | |
| Temperature difference between condensing temperature and water off condenser higher than normal. | Air in condenser. | |
| High discharge pressure. | Condenser tubes dirty or scaled. | Clean condenser tubes. Check water conditioning. |
| | High condenser water temperature. | Reduce condenser water inlet temperature. (Check cooling tower and water circulation.) |
| Temperature difference between condenser water on and water off higher than normal, with normal evaporator pressure. | Insufficient condensing water flow. | Increase the quantity of water through the condenser to proper value. |
| 2. SYMPTOM: ABNORMALLY LOW SUCTION PRESSURE | | |
| Temperature difference between leaving chilled water and refrigerant in evaporator greater than normal with high discharge temperature. | Insufficient charge of refrigerant. | Check for leaks and charge refrigerant into system. |
| | Variable orifice problem. | Remove obstruction. |
| Temperature difference between leaving chilled water and refrigerant in the evaporator greater than normal with normal discharge temperature. | Evaporator tubes dirty or restricted. | Clean evaporator tubes. |
| Temperature of chilled water too low with low motor amperes. | Insufficient load for system capacity. | Check prerotation vane motor operation and setting of low water temperature cutout. |
| 3. SYMPTOM: HIGH EVAPORATOR PRESSURE | | |
| High chilled water temperature. | Prerotation vanes fail to open. | Check the prerotation vane motor positioning circuit. |
| | System overload. | Be sure the vanes are wide open (without overloading the motor) until the load decreases. |
| 4. SYMPTOM: NO OIL PRESSURE WHEN SYSTEM START BUTTON PUSHED | | |
| Low oil pressure displayed on control center; compressor will not start. | Oil pump running in wrong direction. | Check rotation of oil pump (Electrical Connections). |
| | Oil pump not running. | Troubleshoot electrical problem with oil pump VSD. |
| 5. SYMPTOM: UNUSUALLY HIGH OIL PRESSURE DEVELOPS WHEN OIL PUMP RUNS | | |
| Unusually high oil pressure is displayed when the oil pressure display key is pressed when the oil pump is running. | High oil pressure. Transducer defective. | Replace low or high oil pressure transducer. |

TABLE 1 - OPERATION ANALYSIS CHART (CONT'D)

| RESULTS | POSSIBLE | REMEDY |
|--|--|---|
| 6. SYMPTOM: OIL PUMP VIBRATES OR IS NOISY | | |
| Oil pump vibrates or is extremely noisy with some oil pressure when pressing OIL PRESSURE display key. | Oil not reaching pump suction inlet in sufficient quantity. | Check oil level. |
|  <p><i>When oil pump is run without an oil supply it will vibrate and become extremely noisy.</i></p> | Worn or failed oil pump. | Repair/Replace oil pump. |
| 7. SYMPTOM: REDUCED OIL PUMP CAPACITY | | |
| Oil pump pumping capacity. | Excessive end clearance pump. Other worn pump parts. | Inspect and replace worn parts. |
| | Partially blocked oil supply inlet. | Check oil inlet for blockage. |
| 8. SYMPTOM: OIL PRESSURE GRADUALLY DECREASES (Noted by Observation of Daily Log Sheets) | | |
| When oil pump VSD frequency increases to 55 + hz to maintain target oil pressure. | Oil filter is dirty. | Change oil filter. |
| 9. SYMPTOM: OIL PRESSURE SYSTEM CEASES TO RETURN AN OIL/REFRIGERANT SAMPLE | | |
| Oil refrigerant return not functioning. | Filter-drier in oil return system dirty. | Replace old filter-drier with new. |
| | Jet or orifice of oil return jet clogged. | Remove jet, inspect for dirt. Remove dirt using solvent and replace. |
| 10. SYMPTOM: OIL PUMP FAILS TO DELIVER OIL PRESSURE | | |
| No oil pressure registers when pressing OIL PRESSURE display key when oil pump runs. | Faulty oil pressure transducer. Faulty wiring/connectors. | Replace oil pressure transducer. |

SECTION 6 - MAINTENANCE

RENEWAL PARTS

For any required Renewal Parts, refer to the *Renewal Parts – Unit (Form 160.75-RP1)*.

CHECKING SYSTEM FOR LEAKS

Leak Testing During Operation

The refrigerant side of the system is carefully pressure tested and evacuated at the factory.

After the system has been charged, the system should be carefully leak tested with a R-134a compatible leak detector to be sure all joints are tight.

If any leaks are indicated, they must be repaired immediately. Usually, leaks can be stopped by tightening flare nuts or flange bolts. However, for any major repair, the refrigerant charge must be removed. (Refer to *Handling Refrigerant For Dismantling And Repairs on Page 30*)

CONDUCTING R-22 PRESSURE TEST

With the R-134a charge removed and all known leaks repaired, the system should be charged with a small amount of R-22 mixed with dry nitrogen so that a halide torch or electronic leak detector can be used to detect any leaks too small to be found by the soap test.

To test with R-22, proceed as follows:

1. With no pressure in the system, charge R-22 gas into the system through the charging valve to a pressure of 2 PSIG (14 kPa).
2. Build up the system pressure with dry nitrogen to approximately 75 to 100 PSIG (517 to 690 kPa). To be sure that the concentration of refrigerant has reached all part of the system, slightly open the oil charging valve and test for the presence of refrigerant with a leak detector.
3. Test around each joint and factory weld. It is important that this test be thoroughly and carefully done, spending as much time as necessary and using a good leak detector.
4. To check for refrigerant leaks in the evaporator and condenser, open the vents in the evaporator and condenser heads and test for the presence of refrigerant. If no refrigerant is present, the tubes and tube sheets may be considered tight. If refrigerant is detected at the vents, the heads must be removed, the leak located (by means of soap test or leak detector) and repaired.

EVACUATION AND DEHYDRATION OF UNIT

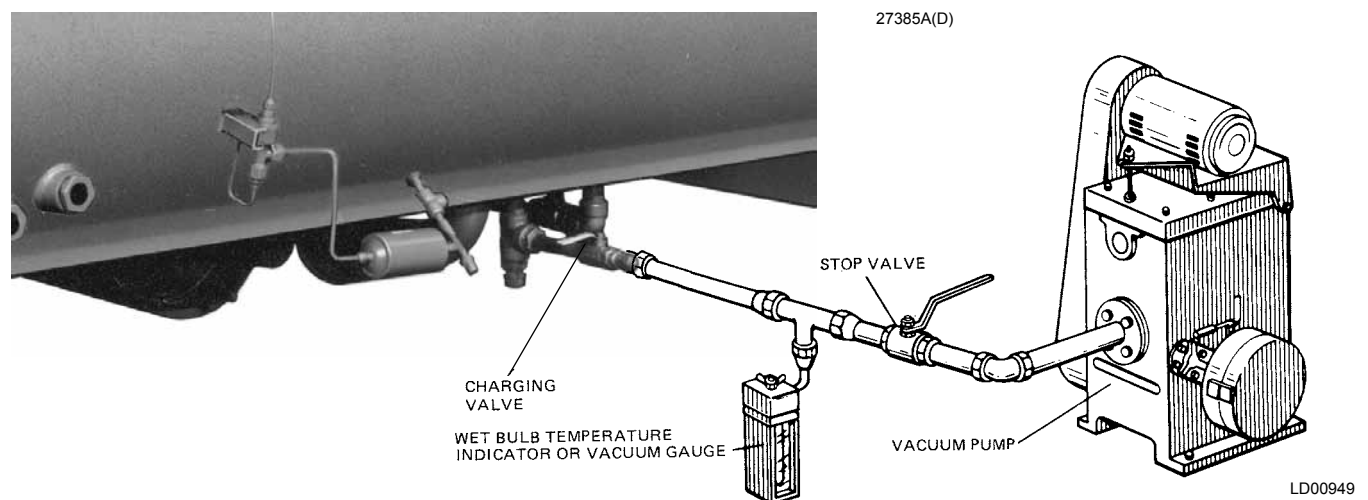

FIGURE 14 - EVACUATION OF CHILLER

TABLE 2 - SYSTEM PRESSURES

| *GAUGE INCHES OF MERCURY (HG) BELOW ONE STANDARD ATMOSPHERE | ABSOLUTE | | | BOILING TEMPERATURES OF WATER °F |
|--|----------|--------------------------------|---------|--|
| | PSIA | MILLIMETERS OF MERCURY (HG) | MICRONS | |
| 0 | 14.696 | 760. | 760,000 | 212 |
| 10.24" | 9.629 | 500. | 500,000 | 192 |
| 22.05" | 3.865 | 200. | 200,000 | 151 |
| 25.98" | 1.935 | 100. | 100,000 | 124 |
| 27.95" | .968 | 50. | 50,000 | 101 |
| 28.94" | .481 | 25. | 25,000 | 78 |
| 29.53" | .192 | 10. | 10,000 | 52 |
| 29.67" | .122 | 6.3 | 6,300 | 40 |
| 29.72" | .099 | 5. | 5,000 | 35 |
| 29.842" | .039 | 2. | 2,000 | 15 |
| 29.882" | .019 | 1.0 | 1,000 | +1 |
| 29.901" | .010 | .5 | 500 | -11 |
| 29.917" | .002 | .1 | 100 | -38 |
| 29.919" | .001 | .05 | 50 | -50 |
| 29.9206" | .0002 | .01 | 10 | -70 |
| 29.921" | 0 | 0 | 0 | |

WATER
FREEZES



*One standard atmosphere = 14.696 PSIA
= 760 mm Hg. absolute pressure at 32°F
= 29.921 inches Hg. absolute at 32°F

NOTES: PSIA = Lbs. per sq. in. gauge pressure
= Pressure above atmosphere
PSIA = Lbs. per sq. in. absolute pressure
= Sum of gauge plus atmospheric pressure

VACUUM TESTING

After the pressure test has been completed, the vacuum test should be conducted as follows:

1. Connect a high capacity vacuum pump, with indicator, to the system charging valve as shown in *Figure 14 on Page 27* and start the pump. (Refer to *Vacuum Dehydration on Page 29.*)
2. Open wide all system valves. Be sure all valves to the atmosphere are closed.
3. Operate the vacuum pump in accordance with VACUUM DEHYDRATION until a wet bulb temperature of +32°F or a pressure of 5 mm Hg is reached. Refer to *Table 2 on Page 28* for corresponding values of pressure.
4. To improve evacuation circulate hot water (not to exceed 125°F, 51.7°C) through the evaporator and condenser tubes to thoroughly dehydrate the shells. If a source of hot water is not readily available, a portable water heater should be employed.

DO NOT USE STEAM. A suggested method is to connect a hose between the source of hot water under pressure and the evaporator head drain connection, out the evaporator vent connection, into the condenser head drain and out the condenser vent. To avoid the possibility of causing leaks, the temperature should be brought up slowly so that the tubes and shell are heated evenly.

5. Close the system charging valve and the stop valve between the vacuum indicator and the vacuum pump. Then disconnect the vacuum pump leaving the vacuum indicator in place.
6. Hold the vacuum obtained in Step 3 in the system for 8 hours; the slightest rise in pressure indicates a leak or the presence of moisture, or both. If, after 24 hours the wet bulb temperature in the vacuum indicator has not risen above 40°F (4.4°C) or a pressure of 6.3 mm Hg, the system may be considered tight.
7. If the vacuum does not hold for 8 hours within the limits specified in Step 6 above, the leak must be found and repaired.

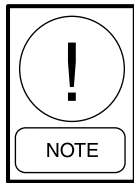

Be sure the vacuum indicator is valved off while holding the system vacuum and be sure to open the valve between the vacuum indicator and the system when checking the vacuum after the 8 hour period.

VACUUM DEHYDRATION

To obtain a sufficiently dry system, the following instructions have been assembled to provide an effective method for evacuating and dehydrating a system in the field. Although there are several methods of dehydrating a system, we are recommending the following, as it produces one of the best results, and affords a means of obtaining accurate readings as to the extent of dehydration.

The equipment required to follow this method of dehydration consists of a wet bulb indicator or vacuum gauge, a chart showing the relation between dew point temperature and pressure in inches of mercury (vacuum), (Refer to *Table 2 on Page 28*) and a vacuum pump capable of pumping a suitable vacuum on the system.

OPERATION

Dehydration of a refrigerant system can be obtained by this method because the water present in the system reacts much as a refrigerant would. By pulling down the pressure in the system to a point where its saturation temperature is considerably below that of room temperature, heat will flow from the room through the walls of the system and vaporize the water, allowing a large percentage of it to be removed by the vacuum pump. The length of time necessary for the dehydration of a system is dependent on the size or volume of the system, the capacity and efficiency of the vacuum pump, the room temperature and the quantity of water present in the system. By the use of the vacuum indicator as suggested, the test tube will be evacuated to the same pressure as the system, and the distilled water will be maintained at the same saturation temperature as any free water in the system, and this temperature can be observed on the thermometer.

If the system has been pressure tested and found to be tight prior to evacuation, then the saturation temperature recordings should follow a curve similar to the typical saturation curve shown as *Figure 15 on Page 29*.

The temperature of the water in the test tube will drop as the pressure decreases, until the boiling point is reached, at which point the temperature will level off and remain at this level until all of the water in the shell is vaporized. When this final vaporization has

taken place the pressure and temperature will continue to drop until eventually a temperature of 35°F (1.6°C) or a pressure of 5 mm Hg. is reached.

When this point is reached, practically all of the air has been evacuated from the system, but there is still a small amount of moisture left. In order to provide a medium for carrying this residual moisture to the vacuum pump, nitrogen should be introduced into the system to bring it to atmospheric pressure and the indicator temperature will return to approximately ambient temperature. Close off the system again, and start the second evacuation.

The relatively small amount of moisture left will be carried out through the vacuum pump and the temperature or pressure shown by the indicator should drop uniformly until it reaches a temperature of 35°F (1.6°C) or a pressure of 5 mm Hg.

When the vacuum indicator registers this temperature or pressure, it is a positive sign that the system is evacuated and dehydrated to the recommended limit. If this level cannot be reached, it is evident that there is a leak somewhere in the system. Any leaks must be corrected before the indicator can be pulled down to 35°F or 5 mm Hg. in the primary evacuation.

During the primary pull-down, keep a careful watch on the wet bulb indicator temperature, and do not let it fall below 35°F (1.6°C). If the temperature is allowed to fall to 32°F (0°C), the water in the test tube will freeze, and the result will be a faulty temperature reading.

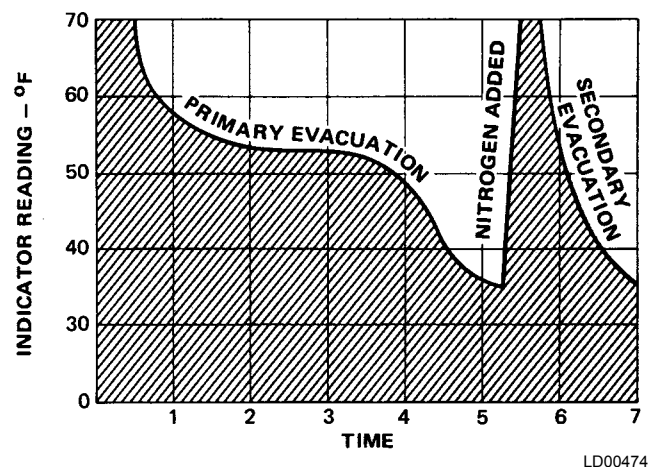

LD00474

FIGURE 15 - SATURATION CURVE

REFRIGERANT CHARGING

To avoid the possibility of freezing liquid within the evaporator tubes when charging an evacuated system, only refrigerant vapor from the top of the drum or cyl-

inder must be admitted to the system pressure until the system pressure is raised above the point corresponding to the freezing point of the evaporator liquid. For water, the pressure corresponding to the freezing point is 8.54 PSIG (58.9 kPa) for R-134a (at sea level).

While charging, every precaution must be taken to prevent moisture laden air from entering the system. Make up a suitable charging connection from new copper tubing to fit between the system charging valve and the fitting on the charging drum. This connection should be as short as possible but long enough to permit sufficient flexibility for changing drums. The charging connection should be purged each time a full container of refrigerant is connected and changing containers should be done as quickly as possible to minimize the loss of refrigerant.

Refrigerant may be furnished in cylinders containing either 30, 50, 125, 1,025 or 1750 lbs. (13.6, 22.6, 56.6, 464 or 794 kg) of refrigerant.

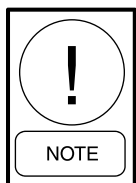

The nameplate on the chiller contains the correct refrigerant charge information for the chiller.

CHECKING THE REFRIGERANT CHARGE DURING UNIT SHUTDOWN

The refrigerant charge is specified for each chiller model. Charge the correct amount of refrigerant and record the level in the evaporator sight glass.

The refrigerant charge should always be checked and trimmed when the system is shut down.

The refrigerant charge level must be checked after the pressure and temperature have equalized between the condenser and evaporator. This would be expected to be 4 hours or more after the compressor and water pumps are stopped. The level should be visible in the sight glass.

Charge the refrigerant in accordance with the method shown under the REFRIGERANT CHARGING, above. The refrigerant level should be observed and the level recorded after initial charging.

HANDLING REFRIGERANT FOR DISMANTLING AND REPAIRS

If it becomes necessary to open any part of the refrigerant system for repairs, it will be necessary to remove the charge before opening any part of the unit. If the chiller is equipped with optional valves, the refrigerant can be isolated in either the condenser or evaporator / compressor while making any necessary repairs.

MEGGING THE MOTOR

While the main disconnect switch and compressor motor starter are open, meg the motor as follows:

1. Using a megohm meter (megger), meg between phases and each phase to ground (Refer to *Figure 16 on Page 30*); these readings are to be interpreted using the graph shown in *Figure 17 on Page 31*.
2. If readings fall below shaded area, remove external leads from motor and repeat test.

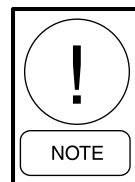

Motor is to be megged with the starter at ambient temperature after 24 hours of idle standby.

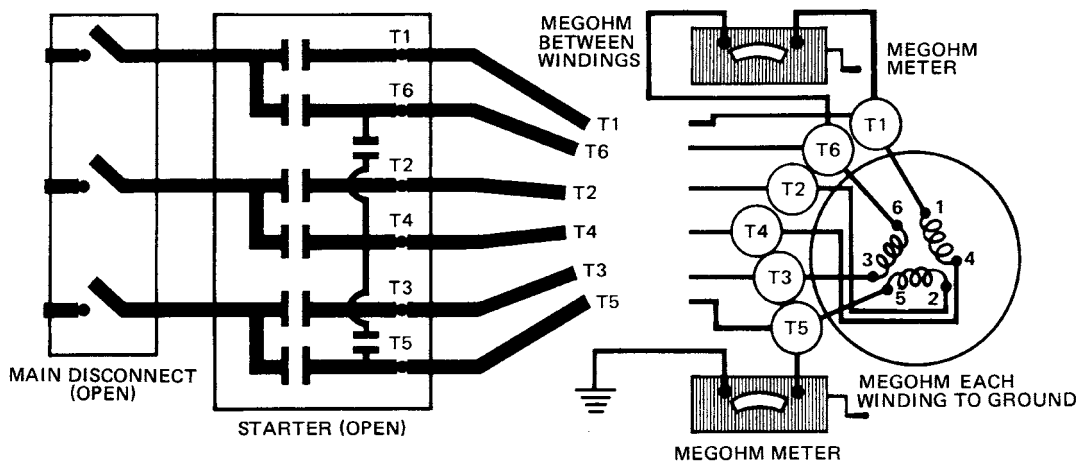

LD00475

FIGURE 16 - DIAGRAM, MEGGING MOTOR WINDINGS

**Minimum Insulation Resistance vs. Temperature (per IEEE Std 43)
Open Motors**

1. Megger readings should be taken after Megger voltage has been applied one minute.
2. If insulation resistance lies to the right of the applicable curve the motor is acceptable for use.
3. If insulation resistance lies to the left of the applicable curve, the motor should not be run. The motor should be heated to 250°F in an effort to remove moisture and obtain an acceptable reading at room ambient. This can be done either by baking in a forced hot air oven or, if proper voltage is available, apply 5 - 10% of rated voltage to motor windings.
4. Any gradual or abrupt decrease in Megger readings over an extended period of time is an indication of deterioration of insulation and / or moisture absorption or oil / dirt contamination.
5. Megger readings of individual phase coils of 200 - 600V motors should be made with coils not under test being grounded.

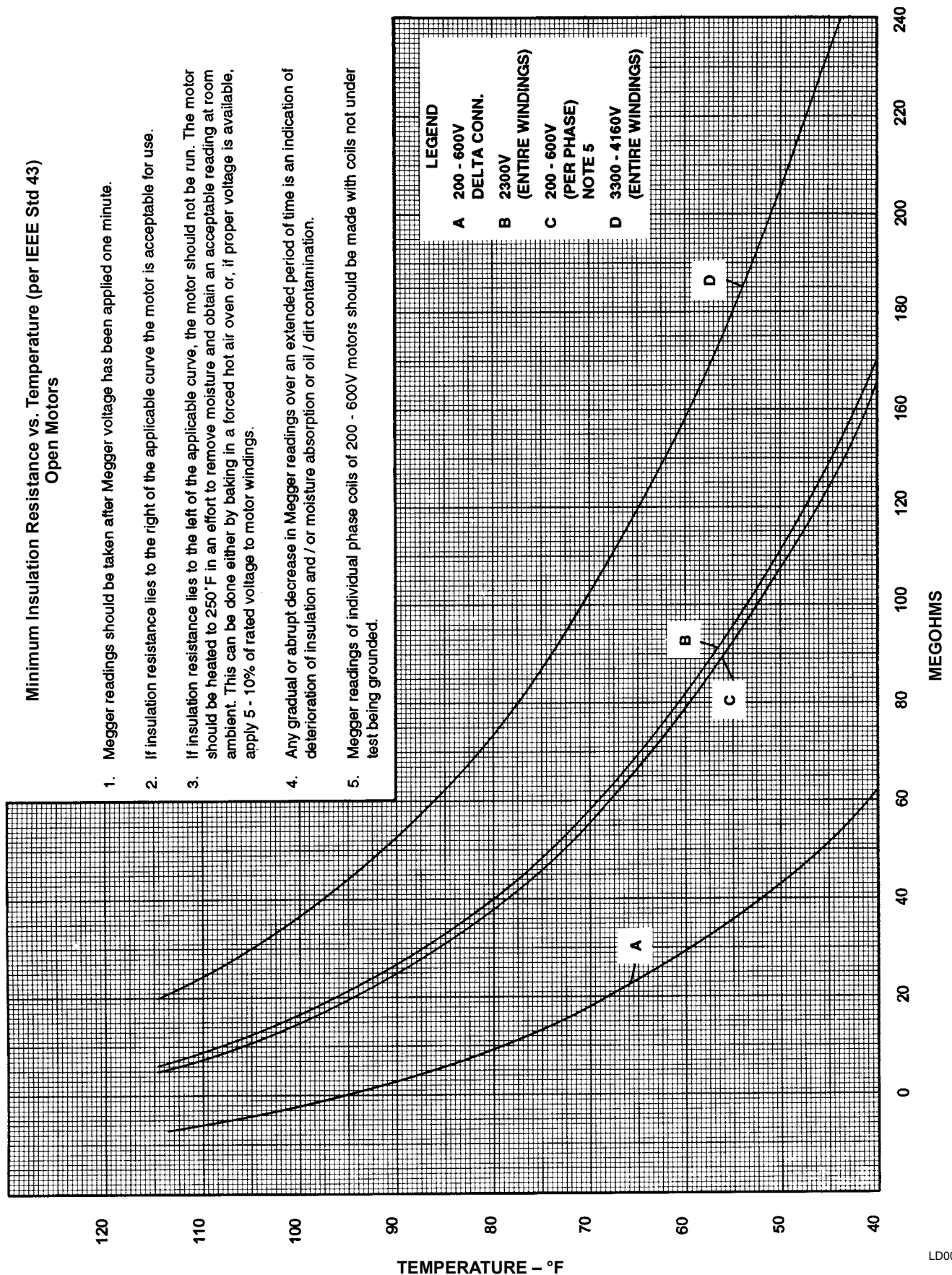

FIGURE 17 - MOTOR STARTER TEMPERATURE AND INSULATION RESISTANCES

Condensers And Evaporators General

Maintenance of condenser and evaporator shells is important to provide trouble free operation of the chiller. The water side of the tubes in the shell must be kept clean and free from scale. Proper maintenance such as tube cleaning, and testing for leaks, is covered on the following pages.

Chemical Water Treatment

Since the mineral content of the water circulated through evaporators and condensers varies with almost every source of supply, it is possible that the water being used may corrode the tubes or deposit heat resistant scale in them. Reliable water treatment companies are available in most larger cities to supply a water treating process which will greatly reduce the corrosive and scale forming properties of almost any type of water.

As a preventive measure against scale and corrosion and to prolong the life of evaporator and condenser tubes, a chemical analysis of the water should be made preferably before the system is installed. A reliable water treatment company can be consulted to determine whether water treatment is necessary, and if so, to furnish the proper treatment for the particular water condition.

Cleaning Evaporator And Condenser Tubes

Evaporator

It is difficult to determine by any particular test whether possible lack of performance of the water evaporator is due to fouled tubes alone or due to a combination of troubles. Trouble which may be due to fouled tubes is indicated when, over a period of time, the cooling capacity decreases and the split (temperature difference between water leaving the evaporator and the refrigerant temperature in the evaporator) increases. A gradual drop-off in cooling capacity can also be caused by a gradual leak of refrigerant from the system or by a combination of fouled tubes and shortage of refrigerant charge. An excessive quantity of oil in the evaporator can also contribute to erratic performance.

Condenser

In a condenser, trouble due to fouled tubes is usually indicated by a steady rise in head pressure, over a period of time, accompanied by a steady rise in condensing temperature, and noisy operation. These symptoms may also be due to foul gas buildup. Purging will remove the foul gas revealing the effect of fouling.

Tube Fouling

Fouling of the tubes can be due to deposits of two types as follows:

1. **Rust or sludge** – which finds its way into the tubes and accumulates there. This material usually does not build up on the inner tube surfaces as scale, but does interfere with the heat transfer. Rust or sludge can generally be removed from the tubes by a thorough brushing process.
2. **Scale** – due to mineral deposits. These deposits, even though very thin and scarcely detectable upon physical inspection, are highly resistant to heat transfer. They can be removed most effectively by circulating an acid solution through the tubes.

Tube Cleaning Procedures

Brush Cleaning of Tubes

If the tube consists of dirt and sludge, it can usually be removed by means of the brushing process. Drain the water sides of the circuit to be cleaned (cooling water or chilled water) remove the heads and thoroughly clean each tube with a soft bristle bronze or nylon brush. **DO NOT USE A STEEL BRISTLE BRUSH.** A steel brush may damage the tubes.

Improved results can be obtained by admitting water into the tube during the cleaning process. This can be done by mounting the brush on a suitable length of 1/8" pipe with a few small holes at the brush end and connecting the other end by means of a hose to the water supply.

The tubes should always be brush cleaned before acid cleaning.

Acid Cleaning Of Tubes

If the tubes are fouled with a hard scale deposit, they may require acid cleaning. It is important that before acid cleaning, the tubes be cleaned by the brushing process described above. If the relatively loose foreign material is removed before the acid cleaning, the acid solution will have less material to dissolve and flush from the tubes with the result that a more satisfactory cleaning job will be accomplished with a probable saving of time.



Acid cleaning should only be performed by an expert. Please consult your local water treatment representative for assistance in removing scale buildup and preventative maintenance programs to eliminate future problems. COMMERCIAL ACID CLEANING

In many major cities, commercial organizations now offer a specialized service of acid cleaning evaporators and condensers. If acid cleaning is required, YORK recommends the use of this type of organization. The Dow Industries Service Division of the Dow Chemical Company, Tulsa, Oklahoma, with branches in principal cities is one of the most reliable of these companies.

Testing For Evaporator And Condenser Tube Leaks

Evaporator and condenser tube leaks in R-134a systems may result in refrigerant leaking into the water circuit, or water leaking into the shell depending on the pressure levels. If refrigerant is leaking into the water, it can be detected at the liquid head vents after a period of shutdown. If water is leaking into the refrigerant, system capacity and efficiency will drop off sharply. If a tube is leaking and water has entered the system, the evaporator and condenser should be valved off from the rest of the water circuit and drained immediately to prevent severe rusting and corrosion. The refrigerant system should then be drained and purged with dry nitrogen to prevent severe rusting and corrosion. If a tube leak is indicated, the exact location of the leak may be determined as follows:

1. Remove the heads and listen at each section of tubes for a hissing sound that would indicate gas leakage. This will assist in locating the section of tubes to be further investigated. If the probable location of the leaky tubes has been determined, treat that section in the following manner (if the location is not definite, all the tubes will require investigations).
2. Wash off both tube heads and the ends of all tubes with water.

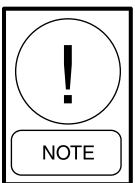

Do not use carbon tetrachloride for this purpose since its fumes give the same flame discoloration that the refrigerant does.

3. With nitrogen or dry air, blow out the tubes to clear them of traces of refrigerant laden moisture from the circulation water. As soon as the tubes are clear, a cork should be driven into each end of the tube. Pressurize the dry system with 50 to 100 PSIG (345 to 690 kPa) of nitrogen. Repeat this with all of the other tubes in the suspected section or, if necessary, with all the tubes in the evaporator or condenser. Allow the evaporator or condenser to remain corked up to 12 to 24 hours before proceeding. Depending upon the amount of leakage, the corks may blow from the end of a tube, indicating the location of the leakage. If not, it will be necessary to make a very thorough test with the leak detector.
4. After the tubes have been corked for 12 to 24 hours, it is recommended that two men working at both ends of the evaporator carefully test each tube – one man removing corks at one end and the other at the opposite end to remove corks and handle the leak detector. Start with the top row of tubes in the section being investigated. Remove the corks at the ends of one tube simultaneously and insert the exploring tube for 5 seconds – this should be long enough to draw into the detector any refrigerant gas that might have leaked through the tube walls. A fan placed at the end of the evaporator opposite the detector will assure that any leakage will travel through the tube to the detector.
5. Mark any leaking tubes for later identification.
6. If any of the tube sheet joints are leaking, the leak should be indicated by the detector. If a tube sheet leak is suspected, its exact location may be found by using a soap solution. A continuous buildup of bubbles around a tube indicates a tube sheet leak.

COMPRESSOR

Maintenance for the compressor assembly consists of checking the operation of the oil return system and changing the dehydrator, checking and changing the oil, checking and changing the oil filters, checking the operation of the oil heater, checking the operation of the oil pump, and observing the operation of the compressor.

Internal wearing of compressor parts could be a serious problem caused by improper lubrication, brought about by restricted oil lines, passages, or dirty oil filters. If the unit is shutting down on (HOT) High Oil Temperature or Low Oil Pressure (OP), change the oil filter element. Examine the oil filter element for the presence of aluminum particles. Aluminum gas seal rings can contact the impeller and account for some aluminum particles to accumulate in the oil filter, especially during the initial start up and first several months

of operation. However, if aluminum particles continue to accumulate and the same conditions continue to stop the unit operation after a new filter is installed, notify the nearest Johnson Controls office to request the presence of a Johnson Controls Service Technician.

ELECTRICAL CONTROLS

For information covering the OptiView™ Control Center operation, refer to the *Optiview™ Control Center – Operation and Maintenance (Form 160.54-01)*.

SECTION 7 - PREVENTIVE MAINTENANCE

It is the responsibility of the owner to provide the necessary daily, monthly and yearly maintenance requirements of the system.

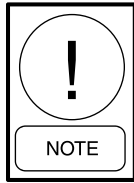

IMPORTANT – *If a unit failure occurs due to improper maintenance during the warranty period; Johnson Controls will not be liable for costs incurred to return the system to satisfactory operation.*

In any operating system it is most important to provide a planned maintenance and inspection of its functioning parts to keep it operating at its peak efficiency. Therefore, the following maintenance should be performed when prescribed.

COMPRESSOR

1. **Oil Filter** – When oil pump VSD frequency increases to 55 hz to maintain target oil pressure.

When the oil filter is changed, it should be inspected thoroughly for any aluminum particles which would indicate possible bearing wear. If aluminum particles are found this should be brought to the attention of the nearest Johnson Controls office for their further investigation and recommendations.

2. **Oil Changing** – The oil in the compressor must be changed annually or earlier if it becomes dark or cloudy. However, quarterly oil analysis can eliminate the need for an annual change provided the analysis indicates there is no problem with the oil.

COMPRESSOR MOTOR

1. Check motor mounting screws frequently to insure tightness.
2. Meg motor windings annually to check for deterioration of windings.

GREASED BEARINGS

Motor Operation and Maintenance manuals are supplied with the chillers providing maintenance schedules and instructions for the specific motors. The following are lubrication schedules for the most common motors:

RAM Motor Lubrication

Frame 143T thru 256T are furnished with double sealed ball bearings, pre-lubricated prior to installation. Grease fittings are not supplied and bearings are designed for long life under standard conditions.

Frames 284T thru 587UZ are furnished with double shielded or open ball or roller bearings. It is necessary to re-lubricate anti-friction bearings periodically. (Refer to *Table 3 on Page 35.*)

TABLE 3 - BEARING LUBRICATION

| FRAME SIZE | STANDARD 8HR/DAY | CONTINUOUS 24HR DAY | GREASE QUANTITY OZ. |
|--------------|------------------|---------------------|---------------------|
| 143T-256T | *7 Years | *3 Years | *1 |
| 284TS-286TS | 210 Days | 70 Days | 1 |
| 324TS-587USS | 150 Days | 50 Days | 2 |

* On frame sizes 143T - 256T, changing bearings at these intervals is recommended. However, removing the seal, cleaning and refilling the bearing and the cavity with recommended grease can re-lubricate these bearings.

Recommended greases for standard applications:

| OPERATING AMBIENT TEMP. -30°C to 50°C | |
|---------------------------------------|-----------------|
| Chevron SRI | (Chevron) |
| Exxon Unirex #2 | (Exxon Corp.) |
| Exxon Polyrex | (Exxon Corp.) |
| Shell Dolum R | (Shell Oil Co.) |

Westinghouse Motor Lubrication:

- Re-greasing should occur at 1000 operating hour intervals.
- Westinghouse recommends using Westinghouse Grease No. 53701.
- Motors with shaft diameters less than 2 3/8 inch require 1 oz of grease per bearing while motors with shaft diameters between 2 3/8 and 3 inches require 1.5 oz.



Mixing different greases is not recommended

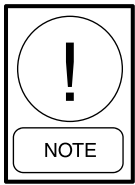

Additional information on motor lubrication and other service issues can be found in the A-C Motors Instruction Manual.

LEAK TESTING

The unit should be leak tested monthly. Any leaks found must be repaired immediately.

EVAPORATOR AND CONDENSER

The major portion of maintenance on the condenser and evaporator will deal with the maintaining the water side of the condenser and evaporator in a clean condition.

The use of untreated water in cooling towers, closed water systems, etc. frequently results in one or more of the following:

1. Scale Formation.
2. Corrosion or Rusting.
3. Slime and Algae Formation.

It is therefore to the benefit of the user to provide for proper water treatment to provide for a longer and more economical life of the equipment. The following recommendation should be followed in determining the condition of the water side of the condenser and evaporator tubes.

1. The condenser tubes should be cleaned annually or earlier if conditions warrant. If the temperature difference between the water off the condenser and the condenser liquid temperature is more than 4°F (2°C) greater than the difference recorded on

a new unit, it is a good indication that the condenser tubes require cleaning. Refer to *SECTION 6 - MAINTENANCE* of this manual for condenser tube cleaning instructions.

2. The evaporator tubes under normal circumstances will not require cleaning. If the temperature difference between the refrigerant and the chilled water increases slowly over the operating season, it is an indication that the evaporator tubes may be fouling or that there may be a water bypass in the waterbox requiring gasket replacement or refrigerant may have leaked from the chiller.
3. Heat recovery condenser tubes should be evaluated similar to evaporator tubes when the heating circuit is a treated, closed loop. Fouling could be detected as ability to meet heat load requirements decreases.

OIL RETURN SYSTEM

1. Change the dehydrator in the oil return system semi-annually or earlier if the oil return system fails to operate.
2. When the dehydrator is changed, the nozzle of the eductor should be checked for any foreign particles that may be obstructing the jet.

ELECTRICAL CONTROLS

1. All electrical controls should be inspected for obvious malfunctions.
2. It is important that the factory settings of controls (operation and safety) not be changed. If the settings are changed without Johnson Controls approval, the warranty will be jeopardized.

|  MAINTENANCE REQUIREMENTS FOR YORK YK CHILLERS | | | | | |
|--|-------|--------|---------|---|-------------|
| PROCEDURE | DAILY | WEEKLY | MONTHLY | YEARLY | OTHER |
| Record operating conditions (on applicable Log Form) | X | | | | |
| Check oil levels | X | | | | |
| Check refrigerant levels | | X | | | |
| Check oil return system operation | | | X | | |
| Check operation of motor starter | | | X | | |
| Check sump heater and thermostat operation | | | X | | |
| Check three-phase voltage and current balance | | | X | | |
| Verify proper operation/setting/calibration of safety controls ¹ | | | X | | |
| Verify condenser and evaporator water flows | | | X | | |
| Leak check and repair leaks as needed ¹ | | | X | | |
| Check and tighten all electrical connections | | | | X | |
| Megohm motor windings | | | | X | |
| Replace oil filter and oil return filter/driers | | | | X | |
| Clean or backflush heat exchanger (VSD, SSS Applications) | | | | X | |
| Replace starter coolant (VSD, SSS Applications) | | | | X | |
| Replace or clean starter air filters if applicable | | | | X ² | |
| Perform oil analysis on compressor lube oil ¹ | | | | X | |
| Perform refrigeration analysis ¹ | | | | X | |
| Perform vibration analysis | | | | X | |
| Clean tubes | | | | X ² | |
| Perform Eddy current testing and inspect tubes | | | | | 2 - 5 Years |
| Lubricate motor | | | | Refer to motor manufacturer's recommendations | |

For operating and maintenance requirements listed above, refer to appropriate service literature, or contact your local YORK Service Office.

¹ This procedure must be performed at the specified time interval by an Industry Certified Technician who has been trained and qualified to work on this type of YORK equipment. A record of this procedure being successfully carried out must be maintained on file by the equipment owner should proof of adequate maintenance be required at a later date for warranty validation purposes.

² More frequent service may be required depending on local operating conditions.

NOTES

The following factors can be used to convert from English to the most common SI Metric values.

TABLE 4 - SI METRIC CONVERSION

| MEASUREMENT | MULTIPLY ENGLISH UNIT | BY FACTOR | TO OBTAIN METRIC UNIT |
|---------------|-------------------------------|-----------|-----------------------|
| Capacity | Tons Refrigerant Effect (ton) | 3.516 | Kilowatts (kW) |
| Power | Horsepower | 0.7457 | Kilowatts (kW) |
| Flow Rate | Gallons / Minute (gpm) | 0.0631 | Liters / Second (l/s) |
| Length | Feet (ft) | 304.8 | Meters (m) |
| | Inches (in) | 25.4 | Millimeters (mm) |
| Weight | Pounds (lbs) | 0.4538 | Kilograms (kg) |
| Velocity | Feet / Second (fps) | 0.3048 | Meters / Second (m/s) |
| Pressure Drop | Feet of Water (ft) | 2.989 | Kilopascals (kPa) |
| | Pounds / Square Inch (psi) | 6.895 | Kilopascals (kPa) |

TEMPERATURE

To convert degrees Fahrenheit (°F) to degrees Celsius (°C), subtract 32° and multiply by 5/9 or 0.5556.

Example: $(45.0^{\circ}\text{F} - 32^{\circ}) \times 0.5556 = 27.2^{\circ}\text{C}$

To convert a temperature range (i.e., a range of 10°F) from Fahrenheit to Celsius, multiply by 5/9 or 0.5556.

Example: $10.0^{\circ}\text{F range} \times 0.5556 = 5.6^{\circ}\text{C range}$



BY JOHNSON CONTROLS

P.O. Box 1592, York, Pennsylvania USA 17405-1592
Copyright © by Johnson Controls 2011
Form 160.75-O1 (211)
Supersedes: 160.75-O1 (309)

Tele. 800-861-1001
www.york.com

Subject to change without notice. Printed in USA
ALL RIGHTS RESERVED