

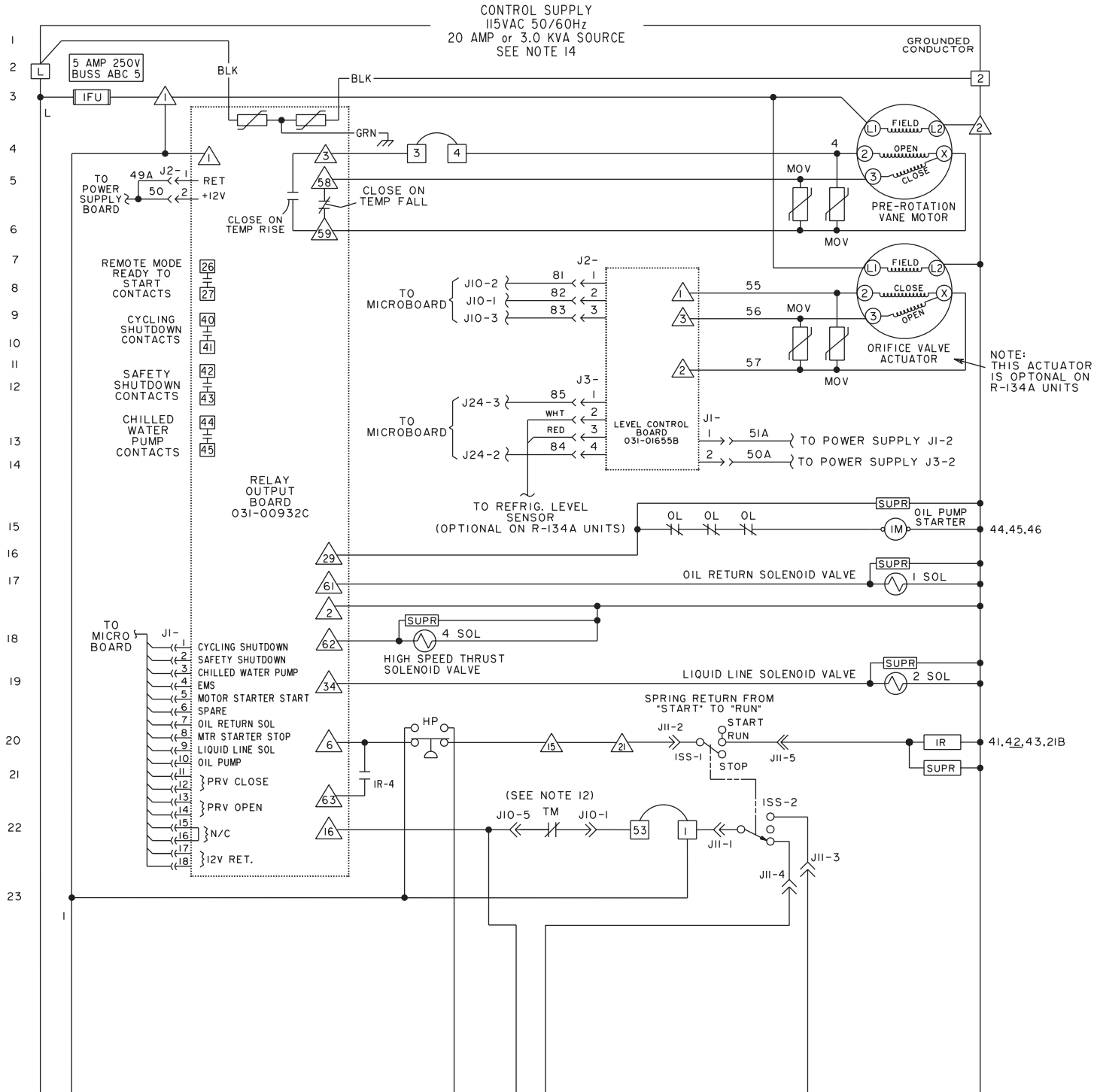







ELEMENTARY DIAGRAM













LEGEND

IHTR	THERMOSTATICALLY CONTROLLED 1500 WATT OIL HEATER (115 VAC)	LWT	LOW WATER TEMPERATURE (PROVIDED BY RT1)
2HTR	THERMOSTATICALLY CONTROLLED 1500 WATT OIL HEATER (OIL PUMP VOLTAGE)	MOV	METAL OXIDE VARISTOR
IM	3 PHASE OIL PUMP STARTER	OL	MOTOR STARTER OVERLOADS
3M	CONDENSER PUMP MOTOR STARTER	OP	LOW OIL PRESSURE (PROVIDED BY TWO TRANSDUCERS)
IR	VSD RUN / IHTR HEATER CONTROL RELAY	OVA	ORIFICE VALVE ACTUATOR
2R	2HTR HEATER CONTROL RELAY	PRV	PRE-ROTATION VANE MOTOR
3R	ORIFICE VALVE MANUAL OVERRIDE CONTROL RELAY	RT1-RT9	RESISTANCE TEMPERATURE SENSING ELEMENT
ISOL	OIL RETURN SOLENOID VALVE	RES	RESISTOR
2SOL	LIQUID LINE SOLENOID VALVE		TRANSIENT SUPPRESSOR
4SOL	HIGH SPEED THRUST SOLENOID VALVE	TB1, TB3, TB6, TB7	TERMINAL BLOCK, FACTORY WIRING — 
ISS	DPDT 3 POSITION ROCKER SWITCH	TB2, TB4, TB5	TERMINAL BLOCK, FIELD CONNECTION — 
2SS	4PST 4 POSITION MANUAL OVERRIDE SWITCH	VMP	VANE MOTOR POTENTIOMETER
2TB	TERMINAL BLOCK, FACTORY WIRING (IN VSD)	VMS	VANE MOTOR SWITCH
3TB	TERMINAL BLOCK, FACTORY WIRING (IN VSD)	-----	FIELD WIRING
IT	CLASS 2 POWER SUPPLY TRANSFORMER	—————	FACTORY WIRING
TM	RUN CONTACT FROM VSD	CIRCUIT BOARD OR ENCLOSURE BOUNDARY
DOC	DIGITAL ORIFICE CONTROLLER	→	JACK (J1, J2,....)
FDT5	FAULTY DISCHARGE TEMP. SENSOR		PLUG (P1, P2,....)
FLA	FULL LOAD AMPS (COMPRESSOR MOTOR)		WIRE ENTRANCE HOLE IN CONTROL PANEL
FU	FUSE	-----	OPTION (WHEN SUPPLIED) BY YORK.
HSDT	HIGH SPEED DRAIN TEMP. (PROBE LOCATED IN COMPRESSOR)	-----	MECHANICAL LINKAGE
PGD	PROXIMITY GAP DISTANCE		SHIELDED CABLE
HDT	REFRIG. HIGH DISCHARGE TEMP. (PROVIDED BY RT2)		METAL OXIDE VARISTOR
HOP	HIGH OIL PRESSURE (PROVIDED BY TWO TRANSDUCERS)		
HOT	HIGH OIL TEMPERATURE (PROVIDED BY RT3)		
HP	HIGH PRESSURE CUTOFF		
LEP	LOW EVAPORATOR PRESSURE (PROVIDED BY EVAP. PRESS TRANSDUCER)		
LLS	LIQUID LEVEL SENSOR (PROBE)		
ILEP	LOW EVAPORATOR PRESSURE CUTOFF (BRINE UNITS ONLY)		
LOT	LOW OIL TEMPERATURE (PROVIDED BY RT3)		
LOTD	LOW OIL TEMP. DIFFERENTIAL (PROVIDED BY RT3 AND CONDENSER PRESS. TRANSDUCER)		

LD03601

NOTES:

1. This wiring diagram describes the standard electronic control scheme for use with a YORK V.S.D. For details of standard modifications, refer to Product Form 160.49-PW13.
2. Field wiring to be in accordance with the National Electrical Code as well as all other applicable codes and specifications. See Product Drawing Form 160.49-PW12 for field wiring connections.
3. Numbers along the left side of diagram are line identification numbers. The numbers along the right side indicate the line number location of relay contacts. An underlined contact location signifies a normally closed contact.
4. Main control panel Class 1 field wiring terminal connection points are indicated by numbers within a rectangle, i.e. . Main control panel factory wiring terminal connection points are indicated by numbers within a triangle, i.e. . Component terminal markings are indicated by numbers within a circle, i.e. . Numbers adjacent to circuit lines are the circuit identification numbers.
5. To cycle unit on and off automatically with contacts other than those shown, install a cycling device between terminals  &  (line 37) (see note 7). If a cycling device is installed, jumper must be removed between terminals  & .
6. To stop unit and not permit it to start again, install a stop device between terminals  &  (Line 33) (see note 7). A remote start-stop switch may be connected to terminals , & (Lines 32 & 33) (see note 7). Remote start-stop switch (Line 32) is operative only in the "remote" operating mode.
7. Device contact rating to be 5 milliamperes at 115 volts A.C.
8. Contact rating is 5A resistive @ 120 volts A.C. or 240 volts A.C.
9. _____
10. For wiring diagram of V.S.D., refer to Product Form 160.00-PW1, 160.00-PW2, 160.00-PW3.
11. _____
12. Run contact (TM) on V.S.D. logic board is set to trip at 105% FLA.
13. Contact rating is 5 amps resistive @ 250 volts A.C. & 30 volts D.C., 2 amp inductive (.4 PF) @ 250 volts A.C. & 30 volts D.C.
14. Field connected control power supply is not required, as control transformer is supplied on the V.S.D.
15. Wires 2* and L* are from V.S.D.
16. Each 115 VAC field-connected inductive load: i.e., relay coil, motor starter coil, etc., shall have a transient suppressor wired in parallel with its coil, physically located at the coil. Spare transient suppressors and control circuit fuses are supplied in a bag attached to the top of the hinged panel.

CONNECTION DIAGRAM (Cont'd)

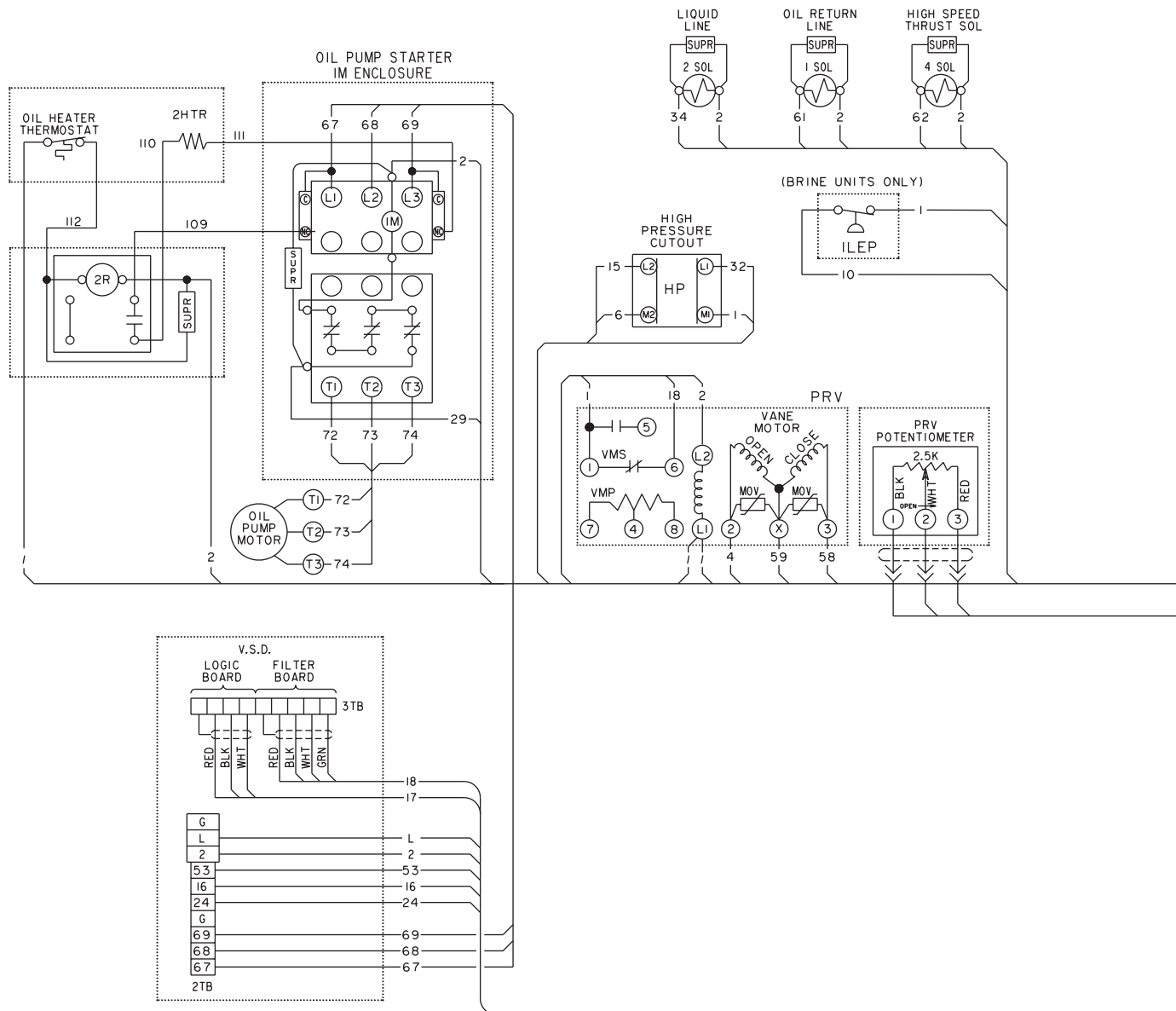

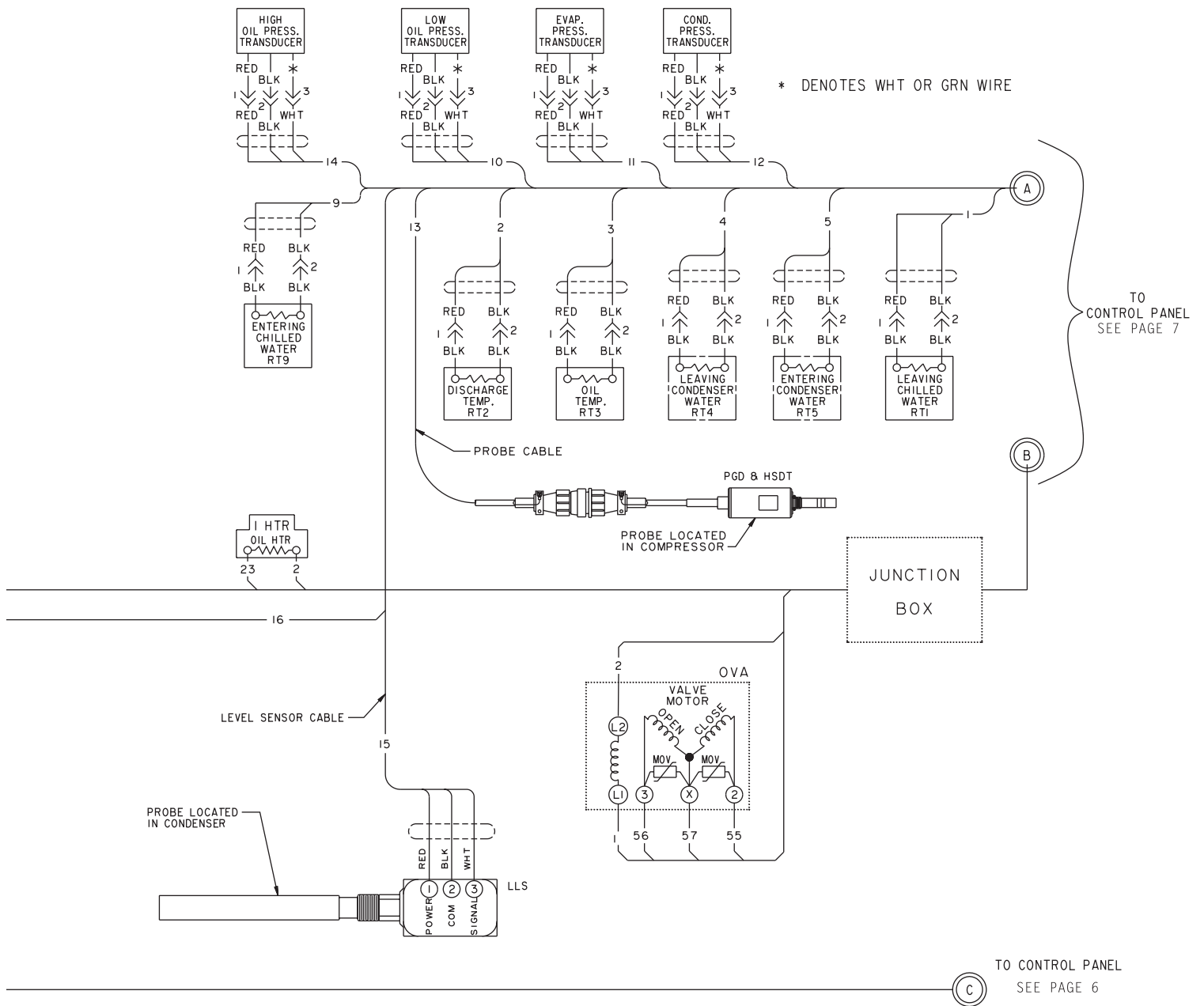

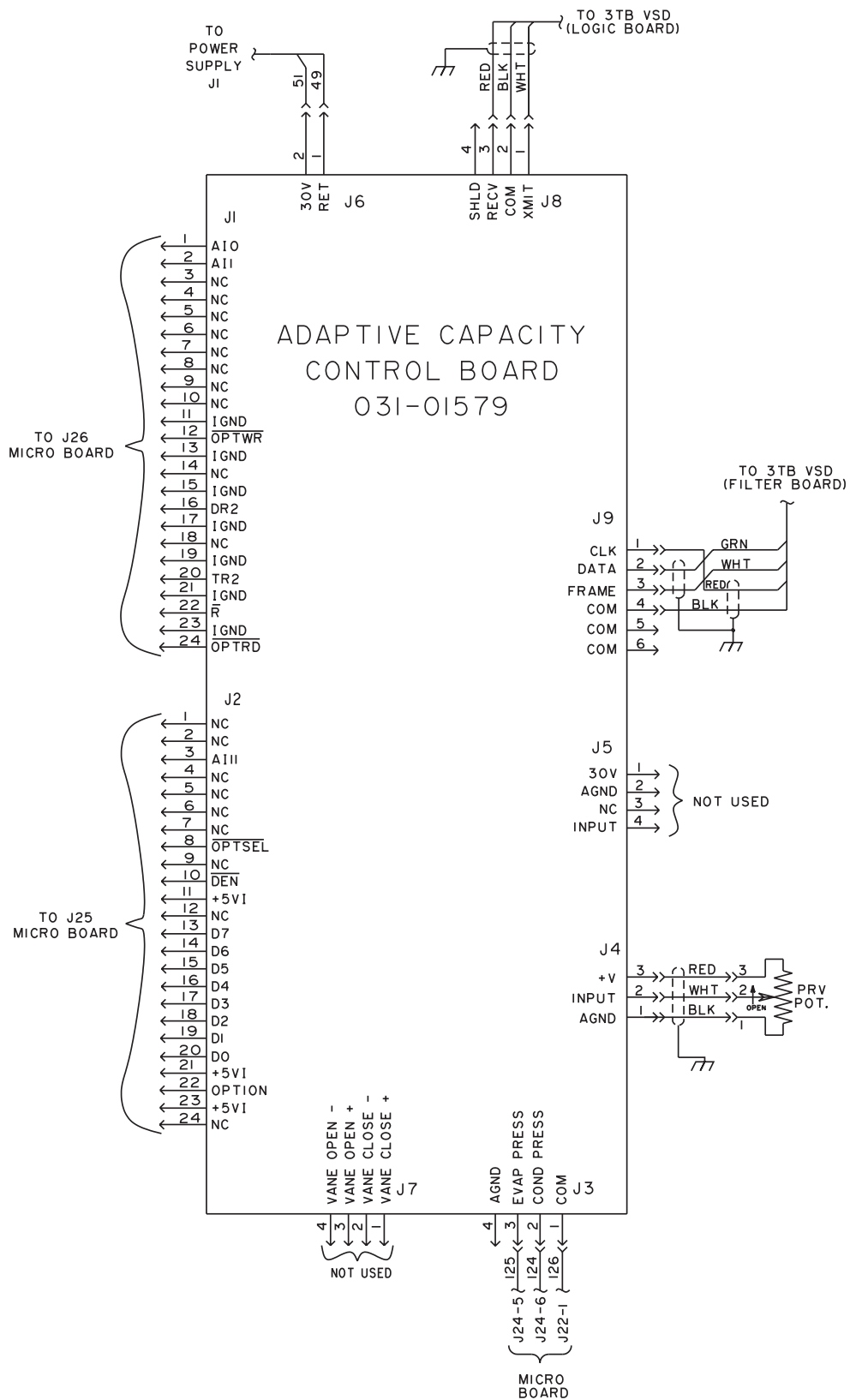

LD03606

PRESSURE-TEMPERATURE CHART							
APPLICATION		DEVICE	UNITS	OPERATING POINT			
CHILLED WATER	BRINE			ON RISE		ON FALL	
✓	✓	HDT	DEG.F/DEG.C	220/104.4		219/103.9	
✓	✓	HOT	DEG.F/DEG.C	180/82.2		179/81.7	
✓	✓	OP	PSID/kPa	25/172		15/104	
✓	✓	HP (R-22)	PSIG/kPa	CUT-OUT 265/1827	INHIBIT PRV OPENING * 246.3/1698	ALLOW PRV OPENING * 245/1689	CUT-IN 205/1413
✓	✓	HP (R-134a)	PSIG/kPa	CUT-OUT 180/1241	INHIBIT PRV OPENING * 162.5/1120	ALLOW PRV OPENING * 160/1103	CUT-IN 120/827
✓		LEP (R-22)	PSIG/kPa	CUT-IN 54.4/375	ALLOW PRV OPENING 57.5/396	INHIBIT PRV OPENING 56.2/387	CUT-OUT 54.3/374
✓		LEP (R-134a)	PSIG/kPa	CUT-IN 25.1/173	ALLOW PRV OPENING 28.0/193	INHIBIT PRV OPENING 27.0/186	CUT-OUT 25.0/172
	✓	ILEP	PSIG				
✓	✓	HOP-FOR FIRST 7 MINUTES OF COMPR. OPERATION	PSID/kPa	100/689.5		99/682.6	
✓	✓	HOP-AFTER THE FIRST 7 MINUTES OF COMPR. OPERATION	PSID/kPa	60/413.7		59/406.8	
✓	✓	FDTs	DEG.F/DEG.C	30.0/-1.10		29.9/-1.20	
✓		LWT	DEG.F/DEG.C	CHILLED LIQUID TEMP. SETPOINT	AT OR ABOVE LCWT= 40/4.4, LWT=4/2.2 BELOW THE CHILLED LIQ. TEMP. SETPOINT; WHEN THE SETPOINT IS RAISED, LWT= 36/2.2 FOR 10 MINUTES. BELOW LWCT=40/4.4, LWT=36/2.2		
	✓	LWT	DEG.F/DEG.C	CHILLED LIQUID TEMP. SETPOINT	LWT = 4/2.2 BELOW THE CHILLED LIQ. TEMP. SETPOINT		
✓	✓	LOT	DEG.F/DEG.C	71.0/21.7		55.0/12.8	
✓	✓	LOTD +	DEG.F/DEG.C	30/16.7		29.9/16.6	
✓	✓	LOTD ++	DEG.F/DEG.C	40/22.2		39.9/22.1	
✓	✓	HSDT	DEG.F/DEG.C	CUTOUT 250/121.1	CUTIN 180/82.2 & MANUAL RESET		

* - FUNCTION PROVIDED BY CONDENSER TRANSDUCER

+ - APPLICABLE IF UNIT WAS SHUTDOWN FOR 30 MINS. OR LESS

++ - APPLICABLE IF UNIT WAS SHUTDOWN FOR GREATER THAN 30 MINS.

OIL PUMP MOTOR		OIL PUMP STARTER OVERLOAD HEATERS				
VOLTS-PH-HZ	FULL LOAD AMPS	MANUFACTURER	MANUFACTURER'S PART NO.	TRIP AMPS	DUAL ELEMENT FUSE SIZE*	% PROTECTION
440-3-60	3.35	FURNAS	K32	4.23	7	126
460-3-60	3.35	FURNAS	K32	4.23	7	126
480-3-60	3.4	FURNAS	K33	4.67	7	137

* Oil pump motor supply fuses located in Variable Speed Drive.



Proud Sponsor
of the 1998
U.S. Olympic Team

36USC380