 PRODUCT DRAWING	Supersedes: Nothing FORM 160.49-PW14 (897) WIRING DIAGRAM YORK SOLID STATE STARTER MILLENNIUM MODEL YK (STYLE C) CHILLERS
YORK INTERNATIONAL CORPORATION P.O. Box 1592, YORK, PA 17405	
CONTRACTOR _____ ORDER NO. _____ YORK CONTRACT NO. _____ YORK ORDER NO. _____	PURCHASER _____ JOB NAME _____ LOCATION _____ ENGINEER _____
<input type="checkbox"/> REFERENCE DATE _____	<input type="checkbox"/> APPROVAL DATE _____
<input type="checkbox"/> CONSTRUCTION DATE _____	

JOB DATA:

CHILLER MODEL NO. _____ NO. OF UNITS _____
 SOLID STATE STARTER, MODEL NO. SSS- _____ LK _____ A
 MOTOR / STARTER POWER _____ VOLTS, 3-PHASE, _____ HERTZ
 OPTIONAL FACTORY INSTALLED DISCONNECT SWITCH _____ AMPS

NOTES:

1. Field Wiring to be in accordance with the latest edition of the National Electrical Code as well as all other applicable codes and specifications.
2. Numbers along the left side of the elementary diagram are line identification numbers. The numbers along the right side indicate the line number location of relay contacts. An underlined contact location signifies a normally closed contact.
3. Terminal board connection points are indicated by numbers within a square i.e. 1TB
15
 Main power connection points are indicated by numbers within a hexagon i.e. L2
 Component terminal markings are indicated by numbers within a circle i.e. 2
 Numbers adjacent to circuit lines are the circuit identification numbers.
4. Terminals L1, L2 & L3 are the main power input terminals and are field connected (see Note 7). Terminals T1, T2 & T3 are the compressor motor load power terminals and are factory connected.
5. The three phase solid state motor overload protection system provides compressor motor overcurrent protection at 105% Full Load Amps.
6. See YORK Control Center Wiring Diagram Product Drawing Form 160.49-PW8.
7. See Field Connections Wiring Diagram, Product Drawing Form 160.49-PW11 for details on the following items: main (if applied) wiring location; power wiring ampacity; line side lug sizes; branch circuit overcurrent protection device(s) (fuse/breaker) sizing; power and control wiring harnesses that require field connection (at extra cost) on units shipped knocked down (see Note 13).
8. Starter incoming power wiring location, Model YK Full Load Amps (FLA), Locked Rotor Amps (LRA), inrush amps, and unit dimensions with YORK Solid State Starter are per Product Drawing 160.49-PA1.
9. Starter approx. overall dimensions are:
 26LK / 33LK – 35" wide x 25-1/2" high x 12" deep; weight is approx. 294 lbs. with transformer. See Notes 7 & 8.

10. The starter will not apply power to the compressor motor if the ambient air temperature is higher than 110°F. The starter cooling pump will begin to run when the compressor motor is started, and continue to run while the compressor motor is operating. When the compressor motor is de-energized, the cooling pump will continue to run until the SCR temperature is reduced to 110°F.
11. The short circuit "withstand capacity", as tested per U.L. Standard 508 (13th Edition), para. 31 at 480 volts, in RMS (Root mean Square equals .707 x peak current), symmetrical current are: SSS 26LK and SSS 33LK, 42,000 amps. The short circuit "withstand capacity" of the YORK SOLID STATE STARTER with optional disconnect switch, as tested per U.L. standard 508 (13th Edition), para. 31 at: 200 - 480 volts – see above. CSA approved for 600 volts SSS 26LK, 25,000 amps. Disconnect switch not available for SSS 33LK.
12. The allowable voltage* range for application of the starter is the same as the compressor motor:

FREQ. HZ	RATED VOLTAGE	NAMEPLATE MOTOR VOLTAGE	EXTREME OPERATING VOLTAGE	
			LOWEST	HIGHEST
60	460	460 or 480	414	508
60	575	575 or 600	518	635
50	380	380	342	402
50	400	380	360	423
50	415	415	374	440

* See Form 160.49-PW11, Note 19, for main power transformer.

13. The YORK Solid State Starter is C.S.A. certified (all 60 Hz models) and U.L. approved (all 60 Hz models, except 575 volts -58) when factory applied to YK units. Units shipped knocked-down will not have C.S.A. or U.L. label.
14. A 3-phase undervoltage safety control (80% dropout voltage, 88% pickup voltage) is furnished as a standard part of the YORK Control Center.
15. If semi-conductor fuses (branch circuit) are furnished (by others) instead of time delay type (by others) – SCR max. I²t (non-repetitive surge rating at 60 Hz half wave) for fuse coordination: SSS 26LK, 3,370,000 (amp)² sec.; SSS 33LK, 6,845,000 (amp)² sec.

LEGEND

1C-6C	Capacitors, snubber, 0.5MF, 500VAC
1FU-3FU	Three phase transformer/oil pump motor fuses
4FU-5FU	Control supply transformer primary fuses
6FU	Control supply transformer secondary fuse
7FU	Trigger and water pump control fuse
Q1-Q6	Semiconductor controlled rectifiers
RES1-3	Snubber resistor - Table 1
RES4-9	Resistor, voltage divider 510K ohms, 1/2W
1RT-3RT	Heatsink thermistor temperature sensors
1T	Trigger control transformer
2T-4T	Feedback current transformers
5T	2.0 KVA control power transformer
1TB,2TB	Terminal block, factory wiring
→	Jack, J1-18
→	Plug, P1 . . . etc.

LD02326

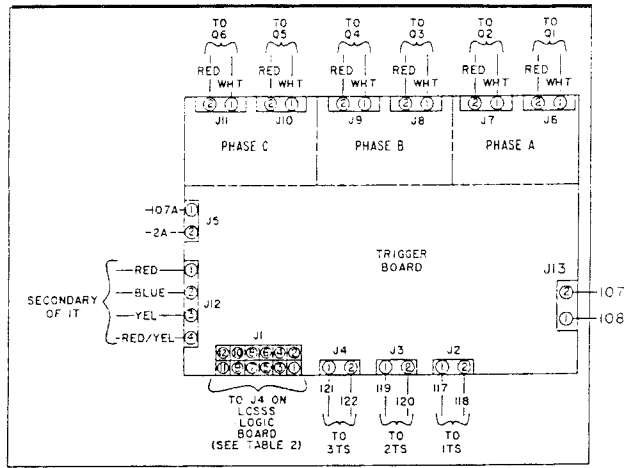
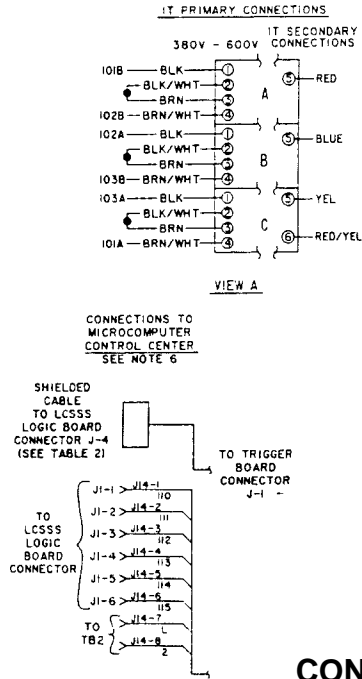

LD02327

CONNECTION DIAGRAM (NOTES 3 & 4)

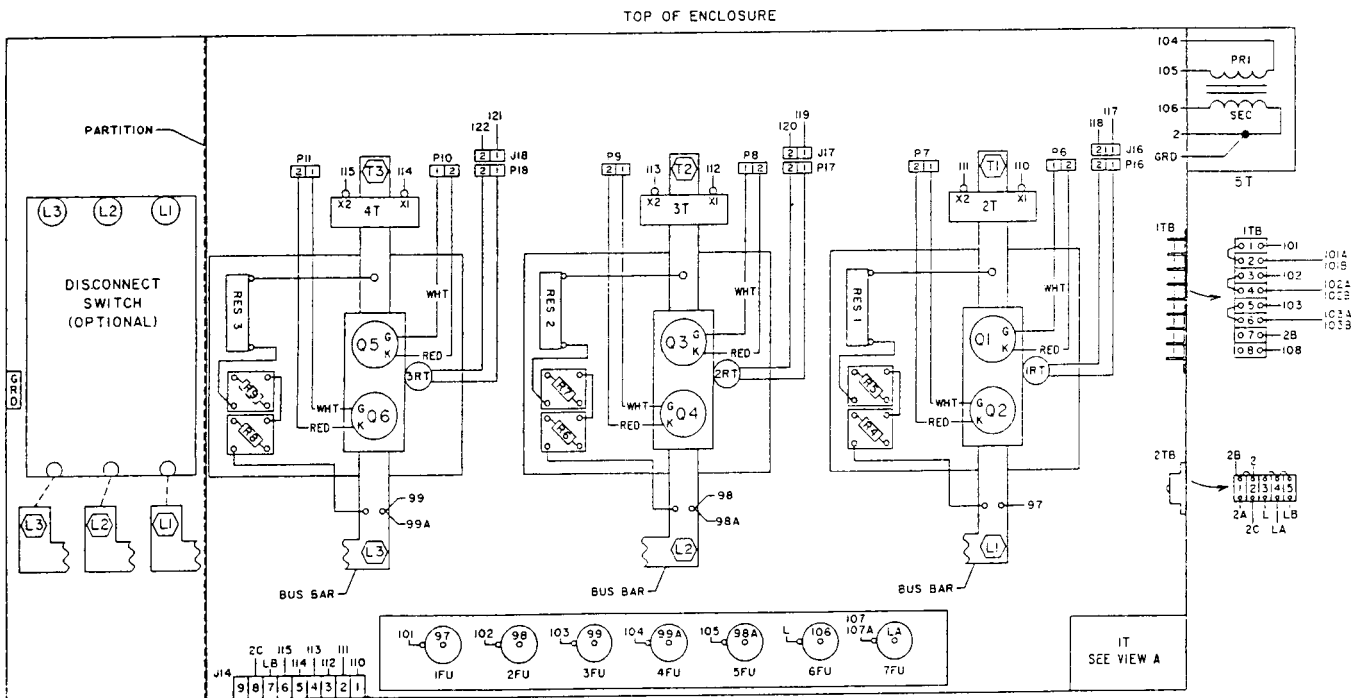

LD02328

ELEMENTARY DIAGRAM (NOTES 2 & 3)

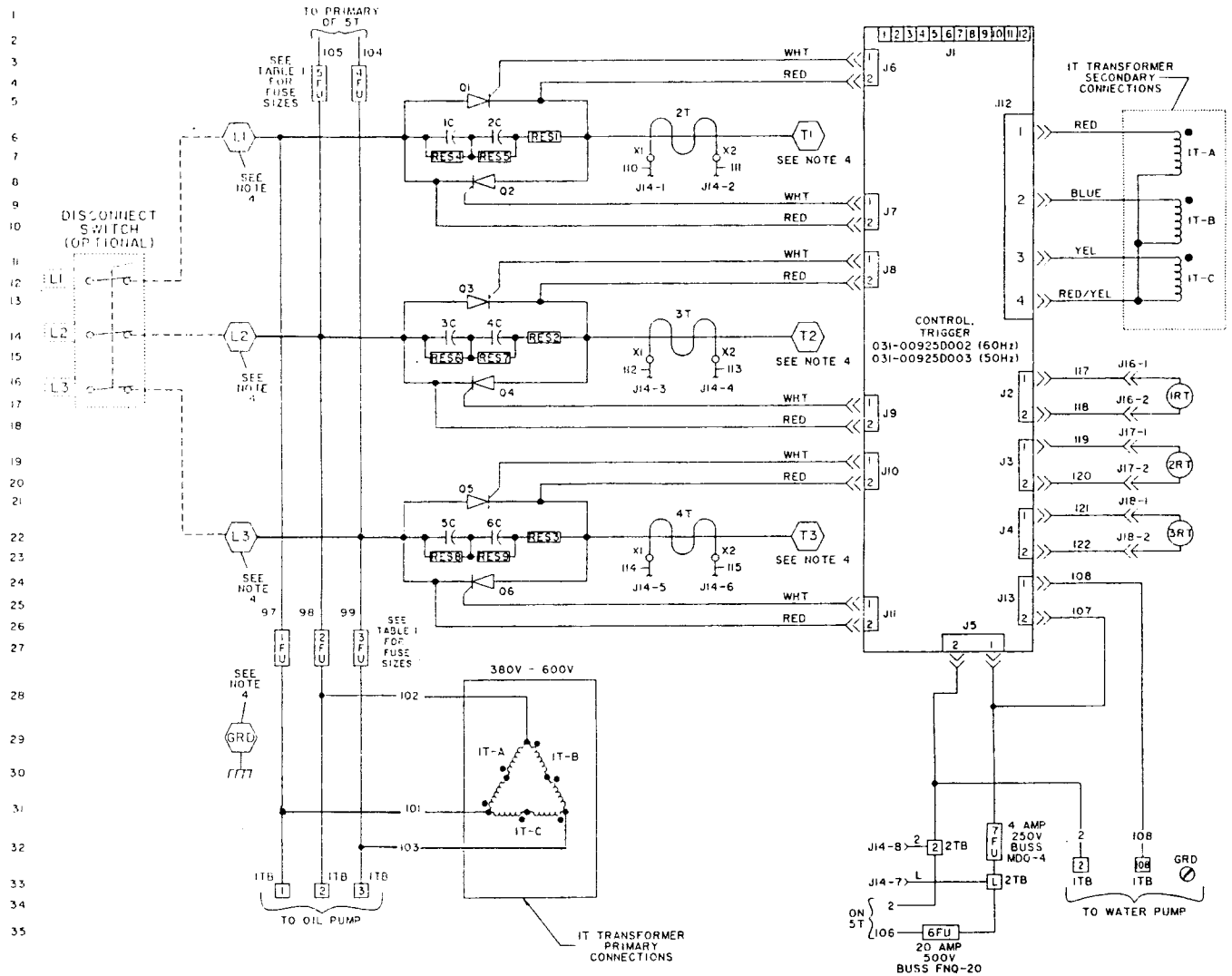

LD02329

TABLE 1

STARTER VOLTAGE	RES 1,2,3 (OHMS)	FUSING IFU, 2FU, 3FU	FUSING 4FU, 5FU	OIL PUMP SUPPLY MAX. CURRENT
380,400,415V	30.0	7A, 500V., BUSS FNQ-7	12A, 500V., BUSS FNQ-12	3.4A
440,460,480V	30.0	7A, 500V., BUSS FNQ-7	10A, 500V., BUSS FNQ-10	3.4A
550,575,600V	36.0	10A, 600V., BUSS KTK-R10	8A, 600V., BUSS KTK-R8	2.7A

TABLE 2

* CONNECTOR PIN	SHIELDED CABLE WIRE COLOR	FUNCTION
1	BLK	P. SUPPLY COM.
2	RED	P. SUPPLY POS.
3	WHT	LOCKOUT
4	GRN	PH. ROT./LOSS
5	ORG	V. CON.
6	BLUE	PH. C VOLTAGE
7	BRN	PH. B VOLTAGE
8	YEL	OUT-OF-LOCK
9	VIOL	PH. A VOLTAGE
10	GRAY	HI TEMP (110°F)
11	WHT/BLK	HI TEMP (110°C)
12	DRAIN WIRE **	SHIELD

* - SAME PIN NUMBERS ARE USED AT BOTH ENDS OF CABLE
 ** NOT CONNECTED AT TRIGGER BOARD END

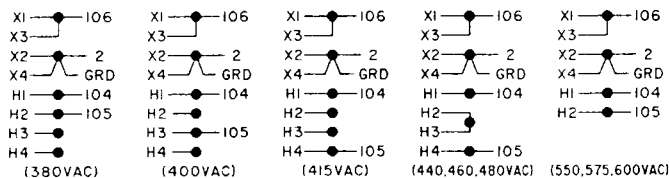

5T TRANSFORMER CONNECTIONS

SOLID STATE STARTER

Type Starting – Reduced voltage; soft start; controlled in-rush maintains the motor current at a constant level throughout the acceleration period, using six silicon controlled rectifiers.

Enclosure – NEMA I, ventilated; hinged door with lock and key latch; for indoor location.

Cooling System – Water cooled; unit mounted, factory wired, inherently protected, 115V, 1/22 HP pump; unit mounted, cleanable heat exchanger.

Mounting – Unit mounted on compressor motor at the factory. Starter factory wired to YORK control center, oil pump motor starters and compressor motor and cooling pump motor.

Meters –

AMMETER – Simultaneous three phase digital readout via MicroComputer Control Center. Three current transformers provide isolated sensing. Accuracy is typically $\pm 3\%$ of full scale. Scales: 26LK 0-2800A, 33LK 0-3500A.

VOLTMETER – Simultaneous three phase, digital readout via MicroComputer Control Center. Three phase potential transformer provides isolated sensing. Accuracy is typically $\pm 3\%$ of full scale. Scale: 0 - 700V for 380 - 600V starters.

ELAPSED TIME METER – Digital readout of elapsed running time (0 - 65,535 hours resettable) via MicroComputer Control Center.

Terminal Lugs – Pressure type (solderless), bolted connector, tin plated aluminum lugs for incoming three phase power line (copper conductors only) connections and system grounding.

Disconnect Switch – Optional unit mounted factory wired disconnects available for SSS 26LK model.

PROTECTIVE DEVICES AND SERVICE INDICATORS (LED TYPE)

Motor Overcurrent Protection – Three-leg sensing solid state current overloads with indicating light and reset button. Ambient temperature compensated protection system provides compressor motor overcurrent protection at 105% full load current and at 150% of "Start" current setting. "Overload" light indicates overcurrent condition has stopped the starter and chiller.

Phase Rotation & Loss – Protection circuit and indicator light. Monitors phase rotation and detects a loss of phase. This protects the motor from running backwards and from starting if single phasing is detected (or fuse is blown).

High Temperature – SCR heat sink high temperature safety protection system with three thermistors (one per phase). "High Temp" indicating light and reset button. Shuts down the starter and chiller, if temperature exceeds safe operating levels. Inhibits startup until temperature falls to an acceptable level.

Transient Overvoltage – dv/dt rate of rise protection for the SCRs is furnished by a snubber resistor - capacitor (R-C)

network. It prevents false firing of the SCRs and reduces the repetitive peak transient voltage (from incoming power line).

Out-Of-Phase Re-energization Protection (Power Fault) – Incoming power line momentary interruption (one electrical cycle duration detected) circuitry to shutdown the starter and chiller. Disconnects starter within 3-1/2 electrical cycles. Auto-reset, restarting unit automatically once fault has cleared. Prevents abnormally high inrush currents, (resulting in high transient motor shaft torque) that can be produced in the motor when it is re-energized soon after a power interruption. "POWER FAULT" indicator is lit and maintained until reset.

Locked Rotor Protection – If the motor is stalled and will not come up to speed, a timer (see below) will shut down the starter and chiller after approximately 40 seconds.

105% Motor Current Light – Indicates the compressor motor current has exceeded 105% full load amps and the 40 second overload timer has started. If for any reason, the compressor motor does not come up to speed, timer will shut down the starter and chiller after approximately 40 seconds. This provides an incomplete start sequence function.

Out-of-Lock Light – Indicates excessive input line-to-line voltage distortion and initiates system shutdown.

Starter Fault Light – Indicates the compressor motor current has exceeded 150% of starting current and the one second overload timer has started; timer shuts down the starter and chiller.

Undervoltage Safety – Prevents startup or causes shutdown if the input line to line voltage (any phase) drops below 80% of the nominal line voltage. Safety is reset when input voltage rises to 88% of nominal line voltage. Displayed on MicroComputer Control Center readout.

Phase Current Unbalance – Causes system shutdown if the percent current unbalance exceeds 30% while operating at or above 80% FLA. Displayed on MicroComputer Control Center readout.

Fusing – Starter three phase control circuit fuse holders with 500 volt dual element fuses for 380 thru 460 volts or 600 volt single element fuses for 575 volts. Protection for gate driver voltmeter transformer, oil pump motor supply and control transformer.

Interlocks – A panel shutdown relay provides positive shutdown of the chiller on any starter safety control shutdown; any chiller safety or operating control shutdown, through the YORK control center, will stop the starter via starter control signal. All interlocks between the YORK control center and starter are furnished completely factory wired.

NOTE: Indicating lights and reset button are on the logic board inside the MicroComputer Control Center.

CONTROL POWER SUPPLY

2.0 KVA – 115 volt, control power transformer (on side of starter) with 20 amp secondary fuse (located within Solid State Starter). Provides control power for starter, YORK control center and starter cooling pump power; completely factory installed and wired.



Proud Sponsor
of the 1998
U.S. Olympic Team

36USC380