



File in SJ4B Manual(s).

SERVICE BULLETIN

Supersedes: *NOTHING*

396

Form 160.49-M2 (SB9)

File with Form: 160.49-M2

SUBJECT: MICROCOMPUTER CONTROL CENTER (YK CENTRIFUGAL CHILLER) - EPROM VERSION C.02F.13 & C.02T.13

ON/ABOUT APRIL 1996, THE SUBJECT CHILLERS WILL BE EQUIPPED WITH EPROM VERSION C.02F.13 (P/N 031-01431-002). ALSO, VERSION C.02T.13 (P/N 031-01431-003) WILL BE AVAILABLE FOR REMOTE CHILLER COMMUNICATIONS APPLICATIONS. THESE EPROMS HAVE THE FOLLOWING OPERATIONAL ENHANCEMENTS:

REFRIGERANT LEVEL CONTROL

THE SUBJECT CHILLERS CAN NOW BE ORDERED WITH AN OPTIONAL CONDENSER REFRIGERANT LEVEL CONTROL CONSISTING OF:

- A.) LEVEL CONTROL ACTUATOR
- B.) REFRIGERANT LEVEL SENSOR, R22 - 025-31713-000
R134a - 025-31712-000
- C.) REFRIGERANT LEVEL CONTROL BOARD, 031-01655-000

THE REFRIGERANT LEVEL SENSOR SENSES THE ACTUAL REFRIGERANT LEVEL IN THE CONDENSER AND OUTPUTS AN ANALOG VOLTAGE TO THE MICRO BOARD THAT REPRESENTS THIS LEVEL. DURING UNIT RUN, THE MICRO BOARD MODULATES THE REFRIGERANT LEVEL ACTUATOR THAT IS CONNECTED TO THE VARIABLE ORIFICE TO MAINTAIN THE CONDENSER REFRIGERANT LEVEL TO THE SETPOINT LEVEL PROGRAMMED INTO THE MICROCOMPUTER CONTROL CENTER BY THE FIELD SERVICE TECHNICIAN.

REF. FIG 2. THE REFRIGERANT LEVEL SENSOR OUTPUTS A VOLTAGE FROM TB-3 OVER THE RANGE OF 0.24 VDC TO 4.31 VDC CORRESPONDING TO A LEVEL OF 0% TO 100%. AT THE END OF EACH LEVEL CONTROL PERIOD (PROGRAMMABLE FROM 1.0 TO 5.0 SECONDS), THE MICRO BOARD DRIVES THE CLOSE OUTPUT (J10-1) OR OPEN OUTPUT (J10-3) TO <1 VDC FOR AN APPROPRIATE NUMBER OF SECONDS TO TURN ON THE CLOSE OR OPEN TRIAC DRIVER ON THE "REFRIGERANT LEVEL CONTROL" BOARD (REF FIG 1). WHEN THE APPROPRIATE TRIAC TURNS ON, IT SHORTS THE CLOSE (2) OR OPEN (3) COIL OF THE "LEVEL CONTROL ACTUATOR" TO COMMON TERMINAL (X). THIS CAUSES THE ACTUATOR TO TURN IN THE DESIRED DIRECTION TO OPEN OR CLOSE THE REFRIGERANT LEVEL VALVE.

AUTOMATIC OPERATION

THE ENTIRE CHILLER RUN TIME IS DIVIDED INTO LEVEL CONTROL PERIODS. THE LEVEL CONTROL PERIOD IS PROGRAMMABLE OVER THE RANGE OF 1.0 TO 5.0 SECONDS. UPON ENTERING "SYSTEM RUN", THE LEVEL CONTROL PERIOD TIMER IS STARTED. WHEN IT HAS ELAPSED, IT IS AGAIN INITIATED. EACH TIME THE LEVEL CONTROL PERIOD HAS ELAPSED, IT IS RE-STARTED.

AT THE END OF EACH LEVEL CONTROL PERIOD, THE PROPORTION ERROR AND RATE AND DIRECTION (TOWARD OR AWAY FROM SETPOINT) OF CHANGE DURING THE LEVEL CONTROL PERIOD ARE EVALUATED TO DETERMINE WHETHER THE RESPONSE SHOULD BE AN OPEN OR CLOSE OUTPUT AND THE DURATION OF THE OUTPUT. THE PROPORTION ERROR IS COMPARED TO PROGRAMMABLE SETPOINTS PROPORTION LIMIT CLOSE AND PROPORTION LIMIT OPEN TO DETERMINE THE INFLUENCE OF PROPORTION ERROR IN THE RESPONSE. THE RATE OF CHANGE AND DIRECTION OF CHANGE DURING THE LEVEL CONTROL PERIOD ARE THEN COMPARED TO PROGRAMMABLE SETPOINTS RATE LIMIT CLOSE AND RATE LIMIT OPEN TO DETERMINE THE INFLUENCE OF RATE OF CHANGE IN THE RESPONSE.

TO EXPLAIN: AT THE COMPLETION OF EACH LEVEL CONTROL PERIOD, THE ACTUAL REFRIGERANT LEVEL IS COMPARED TO THE LEVEL SETPOINT (PROGRAMMABLE FROM 20% TO 80%) TO DETERMINE THE PROPORTION ERROR. AN ERROR OF PLUS OR MINUS 3% IS CONSIDERED ZERO. THE PROPORTION ERROR IS THEN COMPARED TO SETPOINTS PROPORTION LIMIT CLOSE (IF LEVEL BELOW SETPOINT) AND PROPORTION LIMIT OPEN (IF LEVEL ABOVE SETPOINT). BOTH OF THESE SETPOINTS ARE PROGRAMMABLE OVER THE RANGE OF 10% TO 50%. IF THE PROPORTION ERROR EXCEEDS THE LIMIT SETPOINT, THE PROPORTION ERROR INFLUENCE IN THE RESPONSE WILL BE LARGE. IF THE PROPORTION ERROR IS LESS THAN THE LIMIT SETPOINT, THE PROPORTION ERROR INFLUENCE IN THE RESPONSE WILL BE A RESULT OF HOW CLOSE THE PROPORTION ERROR IS TO THE PROPORTION LIMIT SETPOINT. CLOSE YIELDS LARGER INFLUENCE, FURTHER YIELDS SMALLER INFLUENCE. NEXT, THE AMOUNT OF CHANGE IN THE REFRIGERANT LEVEL DURING THE LEVEL CONTROL PERIOD IS COMPARED TO PROGRAMMABLE SETPOINTS RATE LIMIT CLOSE (IF LEVEL LESS THAN SETPOINT) AND RATE LIMIT OPEN (IF LEVEL GREATER THAN SETPOINT). BOTH OF THESE SETPOINTS ARE PROGRAMMABLE OVER THE RANGE OF 10% TO 50%. A LEVEL CHANGE OF PLUS OR MINUS 1% DURING THE LEVEL CONTROL PERIOD IS CONSIDERED ZERO. IF THE LEVEL CHANGE EXCEEDS THE LIMIT SETPOINT, THE RATE INFLUENCE IN THE RESPONSE WILL BE LARGE. IF THE LEVEL CHANGE IS LESS THAN THE LIMIT SETPOINT, THE RATE INFLUENCE IN THE RESPONSE WILL BE A RESULT OF HOW CLOSE THE PERCENTAGE CHANGE IS TO THE RATE LIMIT SETPOINT. CLOSE YIELDS LARGER INFLUENCE, FURTHER YIELDS SMALLER INFLUENCE.

THEREFORE, THE VALUES PROGRAMMED FOR PROPORTION LIMIT CLOSE, PROPORTION LIMIT OPEN, RATE LIMIT CLOSE AND RATE LIMIT OPEN DETERMINE THE SENSITIVITY OF THE RESPONSE. SMALLER VALUES GENERALLY YIELD GREATER RESPONSE FOR THE SAME LEVEL OF REFRIGERANT LEVEL CHANGE IN THE LEVEL CONTROL PERIOD. THE SMALLER THE NUMBER PROGRAMMED FOR THE LEVEL CONTROL PERIOD, THE MORE OFTEN AN OUTPUT IS APPLIED TO THE LEVEL CONTROL ACTUATOR.

ANYTIME THE VANES (PRV) ARE FULLY CLOSED (VANE MOTOR SWITCH CLOSED), THE OUTPUT TO THE LEVEL CONTROL IS OPPOSITE OF THE OUTPUT

TO THE VANE MOTOR. IF A "CLOSE" SIGNAL IS BEING APPLIED TO THE VANE MOTOR, AN "OPEN" SIGNAL WILL BE APPLIED TO THE LEVEL CONTROL. IF AN "OPEN" SIGNAL IS BEING APPLIED TO THE VANE MOTOR, A "CLOSE" SIGNAL WILL BE APPLIED TO THE LEVEL CONTROL. THIS OPERATION IS IN EFFECT WHETHER THE CHILLER IS RUNNING OR SHUTDOWN AND CONTINUES FOR AS LONG AS THE VANE MOTOR SWITCH (VMS) IS CLOSED.

WHILE THE CHILLER IS SHUTDOWN, A "CLOSE" SIGNAL IS CONTINUOUSLY APPLIED TO THE VANE MOTOR. THIS CAUSES THE VANES TO FULLY CLOSE, CLOSING THE VMS. THE CLOSING OF THE VMS INITIATES AN "OPEN" SIGNAL TO THE LEVEL CONTROL. THIS "OPEN" SIGNAL IS APPLIED TO THE LEVEL CONTROL FOR THE DURATION OF THE SHUTDOWN (UNLESS SOMEONE MANUALLY OPERATES THE VANES IN SERVICE MODE; THEN, THE LEVEL CONTROL OUTPUT IS AS EXPLAINED ABOVE). THEREFORE, THE ORIFICE WILL BE IN THE FULL OPEN POSITION PRIOR TO STARTING THE CHILLER.

BECAUSE THE ORIFICE IS IN THE FULL OPEN POSITION WHILE THE CHILLER IS SHUTDOWN, THE SENSED REFRIGERANT LEVEL WILL BE APPROXIMATELY 0%. ELEVATED EVAPORATOR PRESSURE WITH RESPECT TO CONDENSER PRESSURE COULD CAUSE THE LEVEL TO BE HIGHER.

WHEN THE CHILER IS STARTED, AFTER THE VMS OPENS WHEN ENTERING "SYSTEM RUN", A LINEARLY INCREASING RAMP IS APPLIED TO THE LEVEL SETPOINT. THIS RAMP CAUSES THE SETPOINT TO GO FROM THE INITIAL REFRIGERANT LEVEL (APPROXIMATELY 0%) TO THE PROGRAMMED SETPOINT OVER A PERIOD OF 15 MINUTES. WHILE THIS RAMP IS IN EFFECT, "PULLDN LEVEL=XXX%;SETP=XXX%;ACTUAL=XXX%" IS ONE OF THE SCROLLED MESSAGES UNDER THE DISPLAY DATA KEY. "PULLDN LEVEL" IS THE RAMPING SETPOINT THAT WILL RAMP UP TO THE PROGRAMMED SETPOINT "SETP". "SETP" IS THE LEVEL SETPOINT PROGRAMMED BY THE SERVICE TECHNICIAN. "ACTUAL" IS THE PRESENT REFRIGERANT LEVEL. AFTER THE 15 MINUTE RAMP PERIOD HAS ELAPSED, THIS MESSAGE IS REPLACED BY "ACTUAL LEVEL=XXX%;LEVEL SETP=XXX%". IF THE INITIAL REFRIGERANT LEVEL IS GREATER THAN THE PROGRAMMED SETPOINT, THERE IS NO RAMP PERIOD. IT IMMEDIATELY BEGINS TO CONTROL TO THE PROGRAMMED SETPOINT.

WHILE THE CHILLER IS RUNNING, AS LONG AS THE VMS IS OPEN, THE LEVEL CONTROL CONTROLS TO THE PROGRAMMED SETPOINT. HOWEVER, IF THE VANES CLOSE (VMS CLOSES), THE OUTPUTS TO THE LEVEL CONTROL WILL BE OPPOSITE OF THE OUTPUTS APPLIED TO THE VANE MOTOR AS DESCRIBED ABOVE; NORMAL LEVEL CONTROL IS TERMINATED AND ANY RAMP THAT IS IN EFFECT IS TERMINATED. WHEN THE VMS OPENS, IF THE ACTUAL LEVEL IS LESS THAN THE SETPOINT, THE SETPOINT IS RAMPED FROM THE ACTUAL LEVEL TO THE PROGRAMMED SETPOINT OVER A 15 MINUTE PERIOD. "PULLDN LEVEL=XXX%;SETP=XXX%;ACTUAL=XXX%" IS DISPLAYED AS ONE OF THE SCROLLED MESSAGES UNDER THE DISPLAY DATA KEY WHILE THE RAMP IS IN EFFECT. IF THE ACTUAL LEVEL IS GREATER THAN THE LEVEL SETPOINT WHEN THE VMS OPENS, NORMAL LEVEL CONTROL IS RESUMED AND "ACTUAL LEVEL=XXX%;LEVEL SETP=XXX%" IS DISPLAYED INSTEAD OF THE RAMP MESSAGE.

IF THE REFRIGERANT LEVEL SENSOR OUTPUT EVER GOES TO GREATER THAN 4.4 VDC, "WARNING-REFRIGERANT LEVEL OUT OF RANGE" IS DISPLAYED AND THE LEVEL CONTROL ACTUATOR IS DRIVEN OPEN UNTIL THE LEVEL IS WITHIN

RANGE. WHEN WITHIN RANGE, THE WARNING MESSAGE IS AUTOMATICALLY CLEARED AND AUTOMATIC OPERATION RETURNS.

THE REFRIGERANT LEVEL CONTROL IS OPTIONAL. THEREFORE, THE PROGRAM OPERATION DESCRIBED HERE MUST BE "ENABLED" ON THOSE UNITS SO EQUIPPED AND "DISABLED" ON ALL OTHER UNITS USING THE "PROGRAMMING" PROCEDURE BELOW.

MANUAL OPERATION

MANUAL OPERATION OF THE VARIABLE ORIFICE IS ALLOWED IN "SERVICE" MODE IF MANUAL LEVEL CONTROL IS SELECTED USING THE PROGRAMMING PROCEDURE BELOW. THE "PRE-ROTATION VANES" MANUAL CONTROL KEYS ARE USED TO PERFORM THE OPEN, CLOSE, HOLD AND AUTO FUNCTION FOR THE VARIABLE ORIFICE WHEN MANUAL LEVEL CONTROL IS SELECTED. EITHER MANUAL LEVEL CONTROL OR MANUAL VANE CONTROL CAN BE SELECTED USING THE PROCEDURE BELOW. WHEN MANUAL LEVEL CONTROL IS SELECTED, THE PRE-ROTATION VANES KEYS CANNOT BE USED TO CONTROL THE VANES. AFTER THE SERVICE TECHNICIAN HAS COMPLETED ANY MANUAL LEVEL CONTROL OPERATION, THE CONTROL CENTER SHOULD BE RETURNED TO MANUAL VANE CONTROL USING THE PROCEDURE BELOW.

TO DETERMINE IF MANUAL LEVEL CONTROL OR MANUAL VANE CONTROL HAS BEEN SELECTED, PRESS THE DISPLAY DATA KEY. "MANUAL LEVEL CONTROL ALLOWED" OR "MANUAL VANE OPERATION ALLOWED" IS DISPLAYED AS ONE OF THE SCROLLED MESSAGES.

IF MANUAL LEVEL CONTROL IS SELECTED AND THE CONTROL CENTER IS OPERATING IN "SERVICE" MODE, "SYSTEM RUN - AUTO LEVEL CONTROL" IS DISPLAYED UNLESS AN "OPEN" COMMAND IS GIVEN, THEN "SYSTEM RUN - LEVEL VALVE OPENING" IS DISPLAYED. "SYSTEM RUN - LEVEL VALVE CLOSING" IS DISPLAYED WHEN A CLOSE COMMAND IS GIVEN.

FIXED POSITION OPERATION

IT MIGHT BE NECESSARY TO OPERATE THE CHILLER WITH THE VARIABLE ORIFICE IN A FIXED POSITION. THIS COULD BE NECESSARY UNTIL A REPLACEMENT COMPONENT ARRIVES, IF THERE IS A FAILURE OF A REFRIGERANT LEVEL CONTROL COMPONENT.

TO OPERATE THE ORIFICE IN A FIXED POSITION, ENABLE MANUAL LEVEL CONTROL USING THE "PROGRAMMING" PROCEDURE BELOW. THEN, IN SERVICE OPERATING MODE, USE THE "OPEN" AND "CLOSE" VANES KEYS AS DESCRIBED ABOVE UNDER MANUAL OPERATION TO DRIVE THE ORIFICE TO THE DESIRED POSITION. WHEN THE DESIRED POSITION IS ACHIEVED, PRESS THE "HOLD" KEY. THIS MAINTAINS THE ORIFICE AT THE DESIRED POSITION. RETURN TO LOCAL OR REMOTE MODE. THE OPEN AND CLOSE OUTPUTS TO THE ORIFICE ARE NOW DISABLED AND IT WILL REMAIN STATIONARY.

TO RETURN TO AUTOMATIC OPERATION, ENTER SERVICE MODE AND PRESS THE "AUTO" KEY. THEN RETURN TO LOCAL OR REMOTE MODE AS DESIRED.

PROGRAMMING

THE FOLLOWING ARE THE SETPOINTS AND RANGE OF PROGRAMMABLE VALUES THAT APPLY TO THE REFRIGERANT LEVEL CONTROLLER. IT IS RECOMMENDED THAT THE VALUES IN PARENTHESIS BE USED INITIALLY. THESE WILL PROVIDE PROPER OPERATION IN MOST APPLICATIONS. THEY CAN BE CHANGED AS REQUIRED TO REFINE THE OPERATION.

- 1.) LEVEL CONTROL - ENABLE/DISABLE (ENABLE)
- 2.) CONTROL PERIOD - 1.0 TO 5.0 SECONDS (3.5)
- 3.) LEVEL SETPOINT - 20% TO 80% (50%)
- 4.) PROPORTION LIMIT CLOSE - 10% TO 50% (45%)
- 5.) PROPORTION LIMIT OPEN - 10% TO 50% (15%)
- 6.) RATE LIMIT CLOSE - 10% TO 50% (10%)
- 7.) RATE LIMIT OPEN - 10% TO 50% (10%)
- 8.) MANUAL VANES OR MANUAL LEVEL CONTROL (AS REQUIRED)

TO CHANGE ANY OF THE ABOVE SETPOINTS, PERFORM THE FOLLOWING:
(IF IT IS DESIRED TO ONLY CHANGE ONE SETPOINT, USE THE **ADVANCE DAY/SCROLL** KEY TO SCROLL TO THE DESIRED SETPOINT)

- 1.) USE ACCESS CODE **4 2 6 8** TO GAIN ACCESS TO **PROGRAM** MODE.
- 2.) PRESS **PROGRAM** KEY. "PROGRAM MODE, SELECT SETPOINT" IS DISPLAYED.
- 3.) PRESS **OPTIONS** KEY. "ENABLE LEVEL CONTROL = 1 (0=NO;1=YES) IS DISPLAYED. ENTER "1" TO ENABLE LEVEL CONTROL; "0" TO DISABLE LEVEL CONTROL. IF **CANCEL** KEY IS PRESSED, DEFAULT VALUE "DISABLE" IS DISPLAYED.
- 4.) PRESS **ENTER** KEY.
- 5.) PRESS **ADVANCE DAY/SCROLL** KEY. "LEVEL CONTROL PERIOD = X.X SECONDS" IS DISPLAYED. ENTER DESIRED VALUE. IF **CANCEL** KEY IS PRESSED, DEFAULT VALUE 3.5 IS DISPLAYED.
- 6.) PRESS **ENTER** KEY.
- 7.) PRESS **ADVANCE DAY/SCROLL** KEY. "LEVEL SETPOINT = XX%" IS DISPLAYED. ENTER DESIRED VALUE. IF **CANCEL** KEY IS PRESSED, DEFAULT VALUE 50% IS DISPLAYED.
- 8.) PRESS **ENTER** KEY.
- 9.) PRESS **ADVANCE DAY/SCROLL** KEY. "PROPORTION LIMIT CLOSE = XX%" IS DISPLAYED. ENTER DESIRED VALUE. IF **CANCEL** KEY IS PRESSED, DEFAULT VALUE 45% IS DISPLAYED.
- 10.) PRESS **ENTER** KEY.
- 11.) PRESS **ADVANCE DAY/SCROLL** KEY. "PROPORTION LIMIT OPEN = XX% IS DISPLAYED. ENTER DESIRED VALUE. IF **CANCEL** KEY IS PRESSED, DEFAULT VALUE 15% IS DISPLAYED.
- 12.) PRESS **ENTER** KEY.
- 13.) PRESS **ADVANCE DAY/SCROLL** KEY. "RATE LIMIT CLOSE = XX%" IS DISPLAYED. ENTER DESIRED VALUE. IF **CANCEL** KEY IS PRESSED, DEFAULT VALUE 10% IS DISPLAYED.
- 14.) PRESS **ENTER** KEY.
- 15.) PRESS **ADVANCE DAY SCROLL** KEY. "RATE LIMIT OPEN = XX%" IS DISPLAYED. ENTER DESIRED VALUE. IF **CANCEL** KEY IS PRESSED, DEFAULT VALUE 10% IS DISPLAYED.
- 16.) PRESS **ENTER** KEY.

- 17.) PRESS ADVANCE DAY/SCROLL KEY.
"MANUAL CONTROL= 1 (0=VANES;1=LEVEL)" IS DISPLAYED. ENTER "0"
TO ALLOW THE VANES SERVICE KEYS TO CONTROL THE VANES; ENTER
"1" TO ALLOW THE VANES SERVICE KEYS TO CONTROL THE REFRIGERANT
LEVEL CONTROL. IF CANCEL KEY IS PRESSED, DEFAULT VALUE "VANES"
IS DISPLAYED.
- 18.) PRESS ENTER KEY.
- 19.) PRESS ACCESS CODE KEY TO EXIT.

DIAGNOSTICS

THE REFRIGERANT LEVEL SENSOR ANALOG INPUT TO THE MICRO BOARD AND
THE REFRIGERANT LEVEL CONTROL ACTUATOR OUTPUTS FROM THE MICRO BOARD
HAVE BEEN INCORPORATED INTO THE SOFTWARE DIAGNOSTICS AS FOLLOWS:

A/D TEST - THE OPTIONS KEY IS USED TO DISPLAY THE REFRIGERANT LEVEL
SENSOR OUTPUT VOLTAGE.

DIGITAL OUTPUT TEST - THE STATE OF THE LEVEL CONTROL ACTUATOR OPEN
AND CLOSE OUTPUTS CAN BE CHANGED USING THIS
ROUTINE WHILE "LEVEL SOL OPEN" OR "LEVEL SOL
CLOSE" IS DISPLAYED.



S.L. BAER
ELECTRONICS PRODUCT
SERVICE ENGINEER

REFRIGERANT LEVEL
CONTROL BOARD

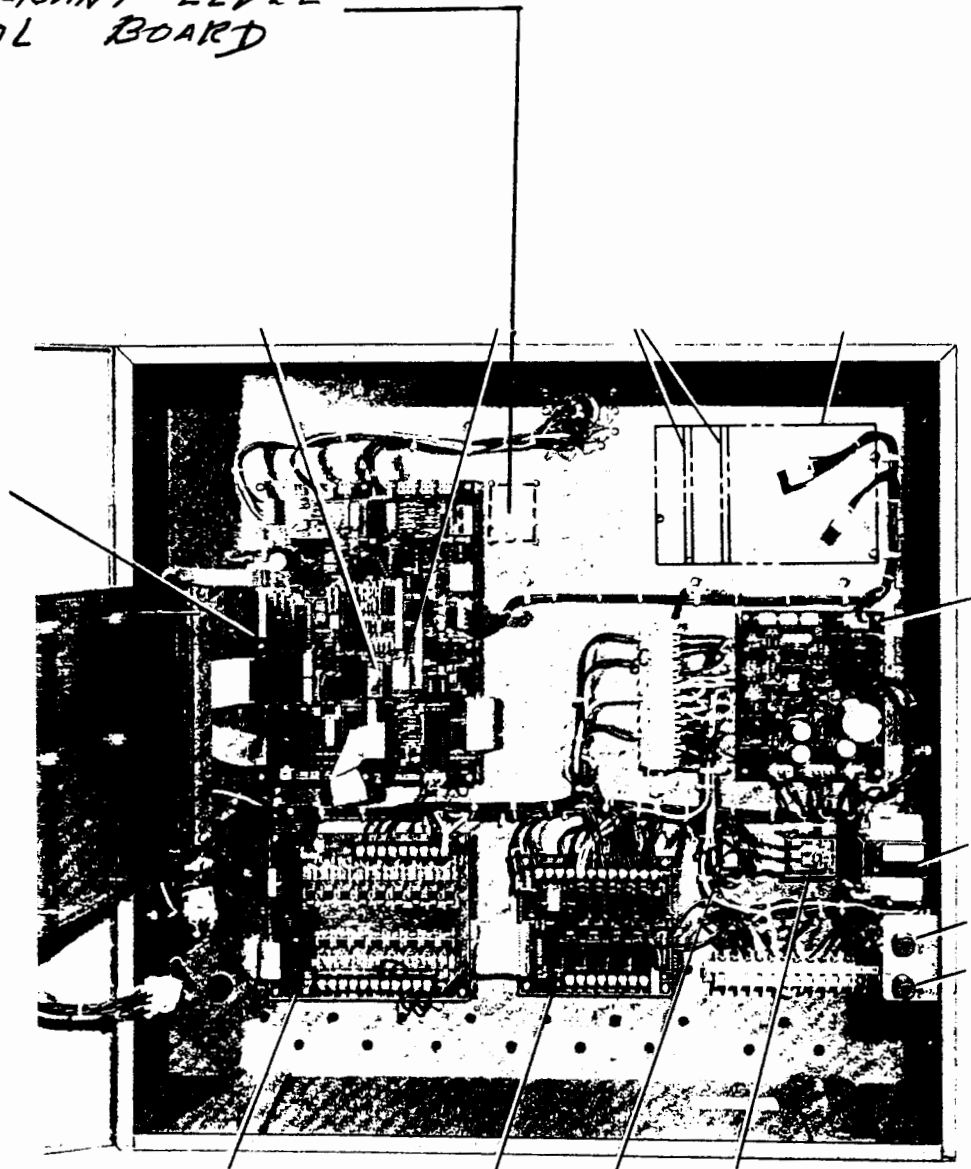

#24618

FIG. 1 - MICROCOMPUTER CONTROL CENTER - DOOR AND HINGED PANEL OPEN

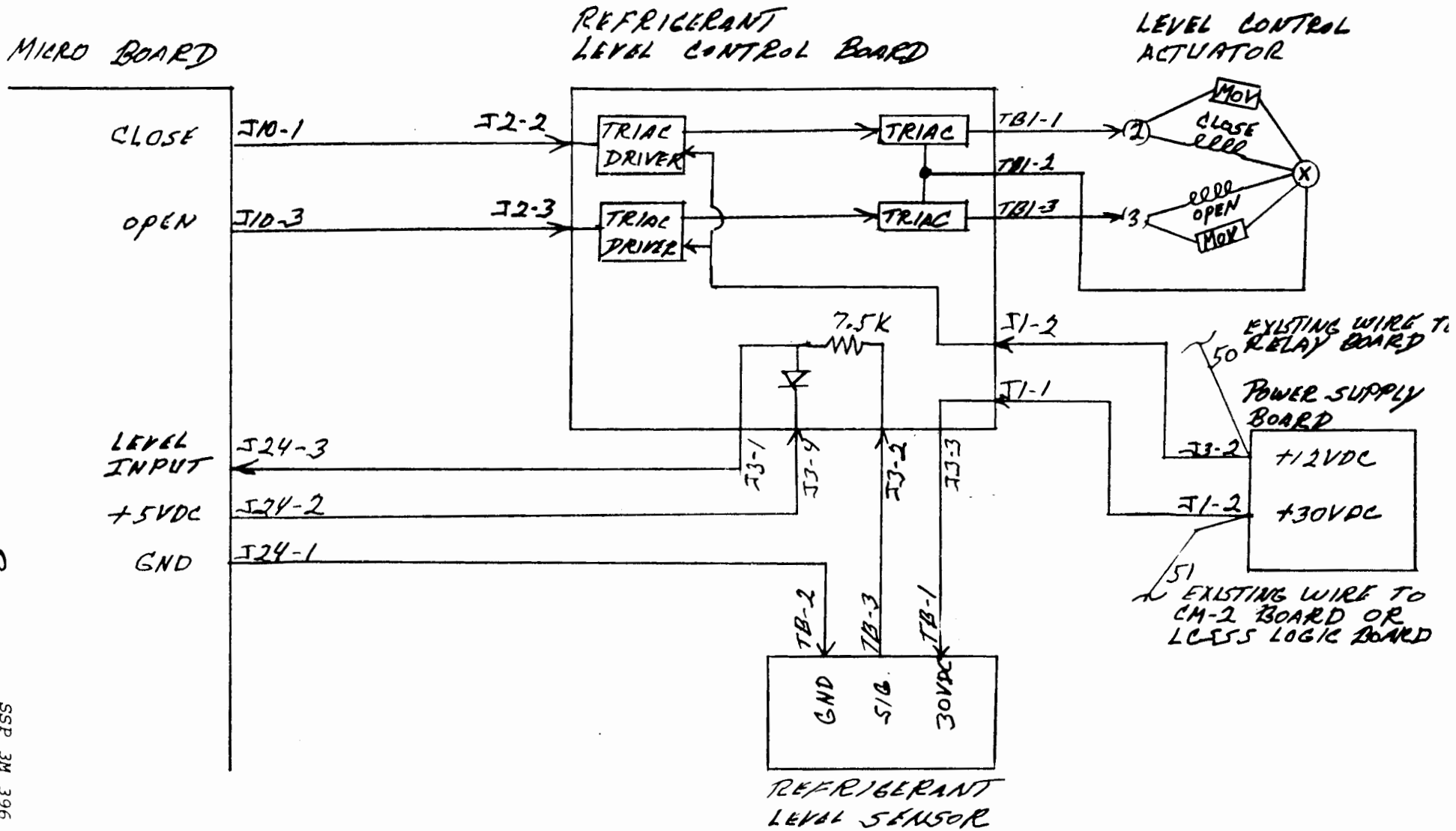

FIG. 2 - REFRIGERANT LEVEL SENSOR BLOCK DIAGRAM/CONNECTIONS

8
SSP 3M 396 . 40
CODE: SC4B