

| | | |
|--|---|---|
|  PRODUCT DRAWING <small>YORK INTERNATIONAL CORPORATION P.O. Box 1592, York, PA 17405</small> | Supersedes: Nothing Form 160.49-PW7 (297) <b style="text-align: center;">WIRING DIAGRAM, MILLENNIUM MODEL YK LIQUID CHILLERS MICROCOMPUTER CONTROL CENTER WITH ELECTRO-MECHANICAL STARTER | |
| CONTRACTOR _____ ORDER NO. _____ YORK CONTRACT NO. _____ YORK ORDER NO. _____ | PURCHASER _____ JOB NAME _____ LOCATION _____ ENGINEER _____ | |
| <input type="checkbox"/> REFERENCE DATE _____ | <input type="checkbox"/> APPROVAL DATE _____ | <input type="checkbox"/> CONSTRUCTION DATE _____ |

For use with York Centrifugal Liquid Chilling Units shown below:

Models YK (Style C)

JOB DATA:

CHILLER MODEL NO. YK _____

NO. OF UNITS _____





COMPRESSOR MOTOR _____ VOLTS, 3-PHASE, _____ Hz

OIL PUMP MOTOR _____ VOLTS, 3-PHASE, _____ Hz, _____ FLA

REMARKS:



















LEGEND

LEGEND

| | | | |
|------|--|---|--|
| IHTR | THERMOSTATICALLY CONTROLLED 1500 WATT OIL HEATER (115 VAC) | LWT | LOW WATER TEMPERATURE (PROVIDED BY RT1) |
| 2HTR | THERMOSTATICALLY CONTROLLED 1500 WATT OIL HEATER (OIL PUMP VOLTAGE) | MOV | METAL OXIDE VARISTOR |
| IM | 3 PHASE OIL PUMP STARTER | OL | MOTOR STARTER OVERLOADS |
| 2M | COMPRESSOR MOTOR STARTER | OP | LOW OIL PRESSURE (PROVIDED BY TWO TRANSDUCERS) |
| 3M | CONDENSER PUMP MOTOR STARTER | OVA | ORIFICE VALVE ACTUATOR |
| IR | COMPRESSOR MOTOR / IHTR HEATER CONTROL RELAY | PRV | PRE-ROTATION VANE MOTOR |
| 2R | 2HTR HEATER CONTROL RELAY | RT1-RT9 | RESISTANCE TEMPERATURE SENSING ELEMENT |
| ISOL | OIL RETURN SOLENOID VALVE | RES | RESISTOR |
| 2SOL | LIQUID LINE SOLENOID VALVE |  | TRANSIENT SUPPRESSOR |
| 3SOL | VENT LINE SOLENOID VALVE | TB1, TB3, TB6, TB7 | TERMINAL BLOCK, FACTORY WIRING —  |
| 4SOL | HIGH SPEED THRUST SOLENOID VALVE | TB2, TB4, TB5 | TERMINAL BLOCK, FIELD CONNECTION —  |
| ISS | DPDT 3 POSITION ROCKER SWITCH | VMP | VANE MOTOR POTENTIOMETER |
| 2SS | 4PST 4 POSITION MANUAL OVERRIDE SWITCH | VMS | VANE MOTOR SWITCH |
| IT | CLASS 2 POWER SUPPLY TRANSFORMER | ----- | FIELD WIRING |
| CM | SOLID STATE OVERLOAD/POWER FAULT CONTACTS (PART OF CM-2 BOARD) | ----- | FACTORY WIRING |
| DOC | DIGITAL ORIFICE CONTROLLER | ----- | CIRCUIT BOARD OR ENCLOSURE BOUNDARY |
| CT | CURRENT TRANSFORMER | → | JACK (J1, J2, ...) |
| FDT5 | FAULTY DISCHARGE TEMP. SENSOR | ⌋ | PLUG (P1, P2, ...) |
| FLA | FULL LOAD AMPS (COMPRESSOR MOTOR) | ○ | WIRE ENTRANCE HOLE IN CONTROL PANEL |
| FU | FUSE | ----- | OPTION (WHEN SUPPLIED) BY YORK. |
| HSDT | HIGH SPEED DRAIN TEMP. | ----- | MECHANICAL LINKAGE |
| PGD | PROXIMITY GAP DISTANCE | ----- | SHIELDED CABLE |
| HDT | REFRIG. HIGH DISCHARGE TEMP. (PROVIDED BY RT2) |  | METAL OXIDE VARISTOR |
| HOP | HIGH OIL PRESSURE (PROVIDED BY TWO TRANSDUCERS) | | |
| HOT | HIGH OIL TEMPERATURE (PROVIDED BY RT3) | | |
| HP | HIGH PRESSURE CUTOUT | | |
| LEP | LOW EVAPORATOR PRESSURE (PROVIDED BY EVAP. PRESS TRANSDUCER) | | |
| LLS | LIQUID LEVEL SENSOR (PROBE) | | |
| ILEP | LOW EVAPORATOR PRESSURE CUTOUT (BRINE UNITS ONLY) | | |
| LOT | LOW OIL TEMPERATURE (PROVIDED BY RT3) | | |
| LOTD | LOW OIL TEMP. DIFFERENTIAL (PROVIDED BY RT3 AND CONDENSER PRESS. TRANSDUCER) | | |

LD00818

NOTES:

- This wiring diagram describes the standard electronic control scheme for use with an electromechanical starter. For details of standard modifications, refer to Product Form 160.49-PW13.
- Field wiring to be in accordance with the National Electrical Code as well as all other applicable codes and specifications. See Product Drawing Form 160.49-PW10 for field wiring connections.
- Numbers along the left side of diagram are line identification numbers. The numbers along the right side indicate the line number location of relay contacts. An underlined contact location signifies a normally closed contact.
- Main control panel Class 1 field wiring terminal connection points are indicated by numbers within a rectangle, i.e.  15. Main control panel factory wiring terminal connection points are indicated by numbers within a triangle, i.e.  5. Component terminal markings are indicated by numbers within a circle, i.e.  1. Numbers adjacent to circuit lines are the circuit identification numbers.
- To cycle unit on and off automatically with contacts other than those shown, install a cycling device between terminals  1 &  13 (line 27) (see note 9). If a cycling device is installed, jumper must be removed between terminals  1 &  13.
- Compressor motor starter with starter interlock contacts (rated 0.5 to 1.0 amp @ 24 volts A.C.) must be per Form 160.45-PA5.1. Control panel shall be grounded.
- Units installed in Canada must have a field supplied CSA approved 30 amp disconnect switch and a 20 amp dual element fuse mounted external to control panel for 115 volt control supply.
- To stop unit and not permit it to start again, install a stop device between terminals  1 &  8 (Line 23 (see note 9)). A remote start-stop switch may be connected to terminals  1,  7 &  8 (Lines 22 & 23) (see note 9). Remote start-stop switch (Line 22) is operative only in the "Remote" operating mode.
- Device contact rating to be 5 milliamperes at 115 volts A.C.
- _____
- Contact rating is 5 amps resistive at 120 volts A.C. or 240 volts A.C.
- Three phase oil pump must be properly phased. L1, L2 & L3 corresponding to phase sequence A, B & C.
- To check motor rotation on initial start-up, install momentary switch between terminals  24 &  25 (Line 35). Depress start switch. After approx. 30 seconds, jog motor with momentary switch. When proper rotation is obtained, replace momentary switch with jumper. Switch must have a minimum contact rating of 2 FLA, 10 LRA at 115 volts A.C.
- Solid state motor overload (CM) is set to trip at 105% FLA. During momentary power interruption (Power Fault), contact opens for 1 second.
- For high and low voltage units, the factory supplied jumper between  1 &  53 must be removed when electromechanical starter overloads and/or safety devices are used. For high voltage (2300-4160) UL and CSA approved units only, electromechanical compressor motor starter overloads (normally closed) must be connected between  1 &  53.
- Contact rating is 5 amps resistive @ 250 volts A.C. & 30 volts D.C., 2 amp inductive (.4 PF) @ 250 volts A.C. & 30 volts D.C.
- Each 115 VAC field-connected inductive load: i.e., relay coil, motor starter coil, etc., shall have a transient suppressor wired in parallel with its coil, physically located at the coil. Spare transient suppressors and control circuit fuses are supplied in a bag attached to the top of the hinged panel.

ELEMENTARY DIAGRAM (Cont'd.)

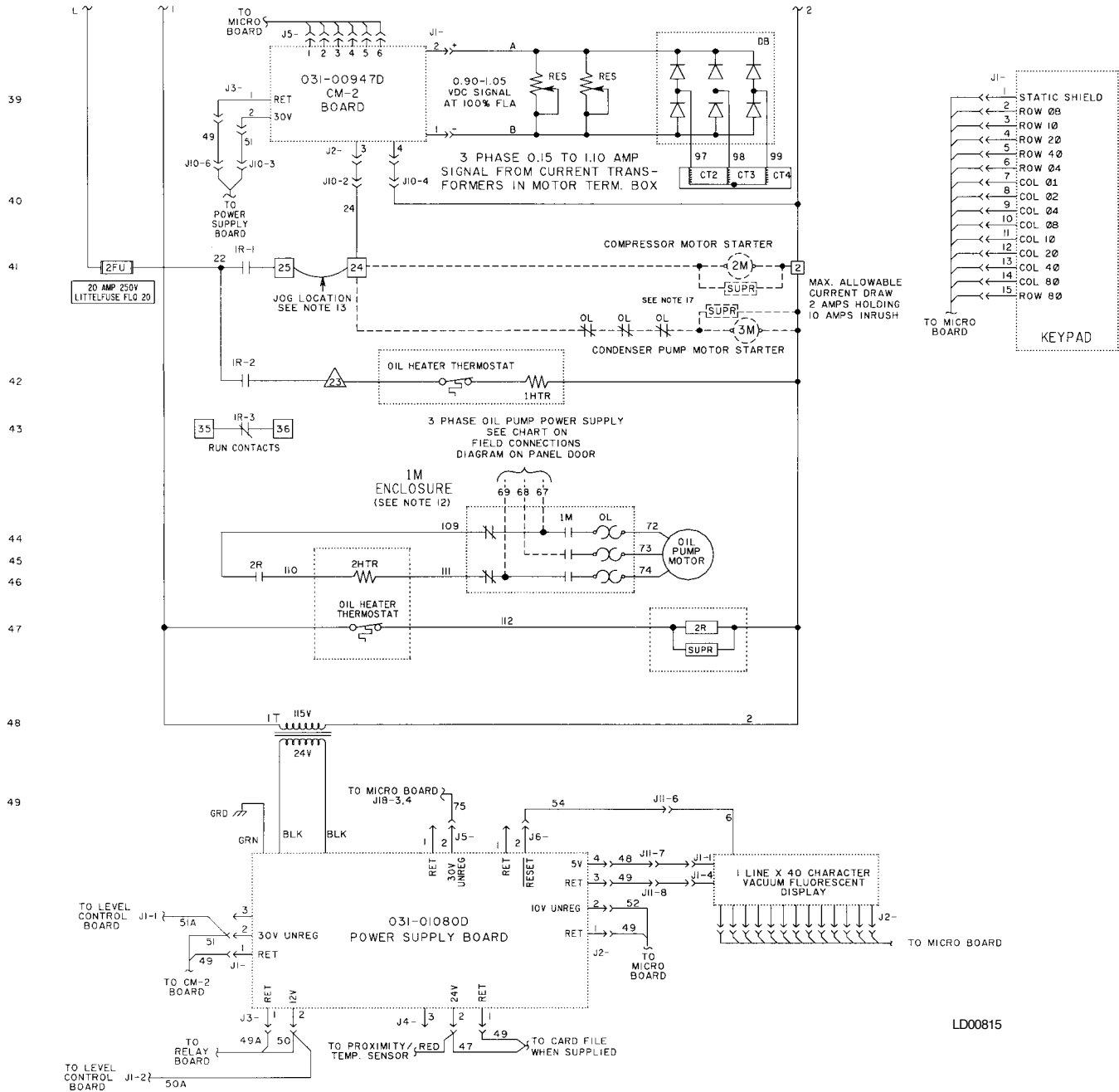

TIMING DIAGRAM

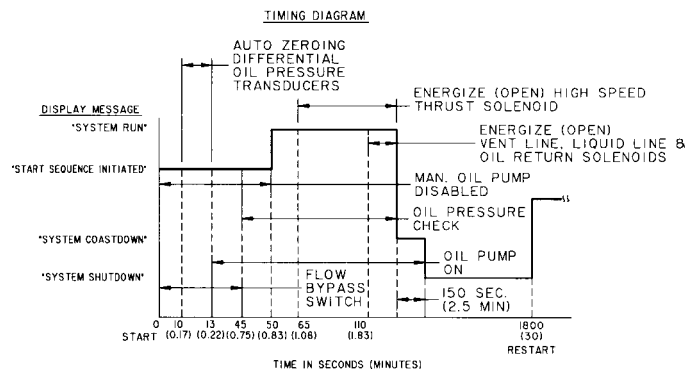

| PRESSURE-TEMPERATURE CHART | | | | | | | |
|----------------------------|-------|---|-------------|----------------------------------|--|------------------------------------|---------------------|
| APPLICATION | | DEVICE | UNITS | OPERATING POINT | | | |
| CHILLED WATER | BRINE | | | ON RISE | | ON FALL | |
| ✓ | ✓ | HDT | DEG.F/DEG.C | 220/104.4 | | 219/103.9 | |
| ✓ | ✓ | HOT | DEG.F/DEG.C | 180/82.2 | | 179/81.7 | |
| ✓ | ✓ | OP | PSID/kPa | 25/172 | | 15/104 | |
| ✓ | ✓ | HP (R-22) | PSIG/kPa | CUT-OUT 265/1827 | INHIBIT PRV OPENING * 246.3/1698 | ALLOW PRV OPENING * 245/1689 | CUT-IN 205/1413 |
| ✓ | ✓ | HP (R-134a) | PSIG/kPa | CUT-OUT 180/1241 | INHIBIT PRV OPENING * 162.5/1120 | ALLOW PRV OPENING * 160/1103 | CUT-IN 120/827 |
| ✓ | | LEP (R-22) | PSIG/kPa | CUT-IN 54.4/375 | ALLOW PRV OPENING 57.5/396 | INHIBIT PRV OPENING 56.2/387 | CUT-OUT 54.3/374 |
| ✓ | | LEP (R-134a) | PSIG/kPa | CUT-IN 25.1/173 | ALLOW PRV OPENING 28.0/193 | INHIBIT PRV OPENING 27.0/186 | CUT-OUT 25.0/172 |
| | ✓ | ILEP | PSIG | | | | |
| ✓ | ✓ | HOP-FOR FIRST 7 MINUTES OF COMPR. OPERATION | PSID/kPa | 125/861.9 | | 124/855.0 | |
| ✓ | ✓ | HOP-AFTER THE FIRST 7 MINUTES OF COMPR. OPERATION | PSID/kPa | 60/413.7 | | 59/406.8 | |
| ✓ | ✓ | FDTS | DEG.F/DEG.C | 30.0/-1.10 | | 29.9/-1.20 | |
| ✓ | | LWT | DEG.F/DEG.C | CHILLED LIQUID TEMP. SETPOINT | AT OR ABOVE LCWT= 40/4.4, LWT=4/2.2 BELOW THE CHILLED LIQ. TEMP. SETPOINT: WHEN THE SETPOINT IS RAISED, LWT= 36/2.2 FOR 10 MINUTES. BELOW LWCT=40/4.4, LWT=36/2.2 | | |
| | ✓ | LWT | DEG.F/DEG.C | CHILLED LIQUID TEMP. SETPOINT | LWT = 4/2.2 BELOW THE CHILLED LIQ. TEMP. SETPOINT | | |
| ✓ | ✓ | LOT | DEG.F/DEG.C | 71.0/21.7 | | 55.0/12.8 | |
| ✓ | ✓ | LOTD† | DEG.F/DEG.C | 30/16.7 | | 29.9/16.6 | |
| ✓ | ✓ | LOTD†† | DEG.F/DEG.C | 40/22.2 | | 39.9/22.1 | |
| ✓ | ✓ | HSDT | DEG.F/DEG.C | CUTOUT 250/121.1 | CUTIN 180/82.2 & MANUAL RESET | | |

- * - FUNCTION PROVIDED BY CONDENSER TRANSDUCER
† - APPLICABLE IF UNIT WAS SHUTDOWN FOR 30 MINS. OR LESS
†† - APPLICABLE IF UNIT WAS SHUTDOWN FOR GREATER THAN 30 MINS.

LD00817

CONNECTION DIAGRAM

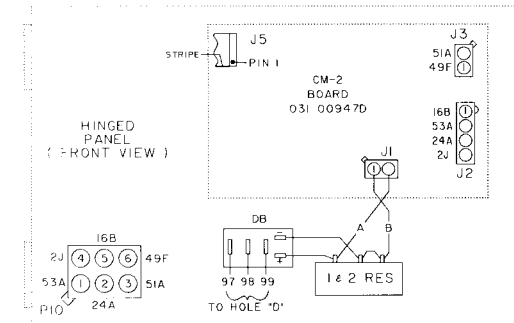
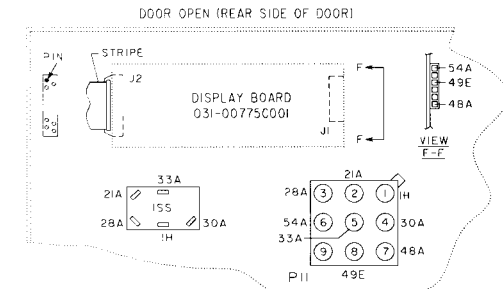

- TO REMOTE LOWCWT SET POINT (PWM SIGNAL) 1,19 (SEE NOTES 1,9)
- TO REMOTE CURRENT LIMIT SET POINT (PWM SIGNAL) 1,20 (SEE NOTES 1,9)
- TO CHILLED WATER PUMP CONTACTS 44,45 (SEE NOTES 16,17)
- TO REMOTE MODE READY TO START CONTACTS 26,27 (SEE NOTES 16,17)
- TO CYCLING SHUTDOWN CONTACTS 40,41 (SEE NOTES 16,17)
- TO RUN CONTACTS 35,36 (SEE NOTES 11,17)
- TO CONDENSER PUMP MOTOR STARTER 2,24
- TO AUXILIARY SAFETY SHUTDOWN CONTACTS 1,31 (SEE NOTES 1,9)
- TO CHILLED WATER PUMP INTERLOCK OR FLOW SWITCH 1,12 (SEE NOTE 9)
- TO SAFETY SHUTDOWN CONTACTS 42,43 (SEE NOTES 16,17)
- TO CONTACTS THAT CYCLE UNIT 1,7,8,13 (SEE NOTES 5,8,9)
- TO COMPRESSOR MOTOR STARTER 1,3,4,13,24,53 WITH CONTROL SUPPLY TRANSFORMER 1,2 (GROUNDED CONDUCTOR) 11V, 50/60HZ, 15AMPS (SEE NOTES 6,7)
- TO MULTI-UNIT 1 SEQUENCE CONTACTS 1,9 (SEE NOTES 1,9)

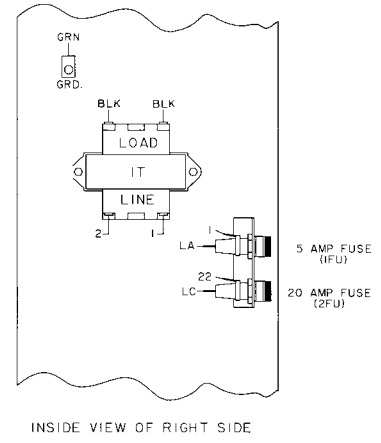
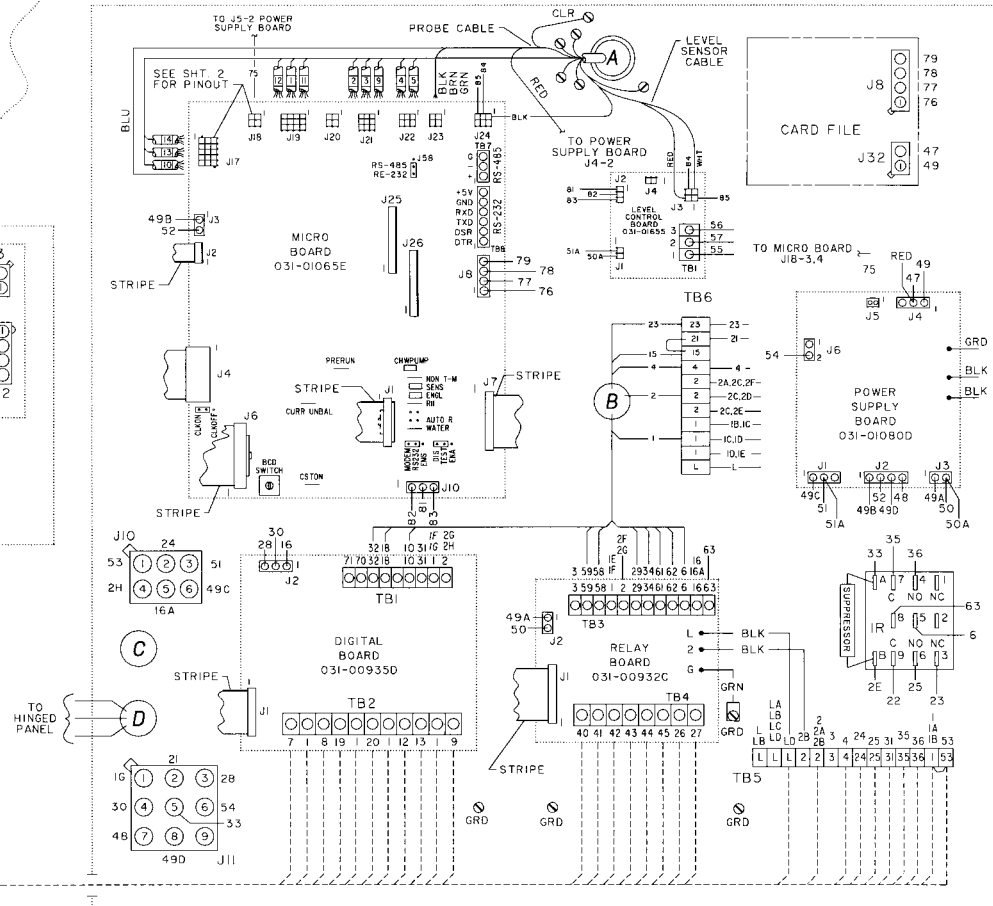

CONNECTION DIAGRAM (Cont'd.)

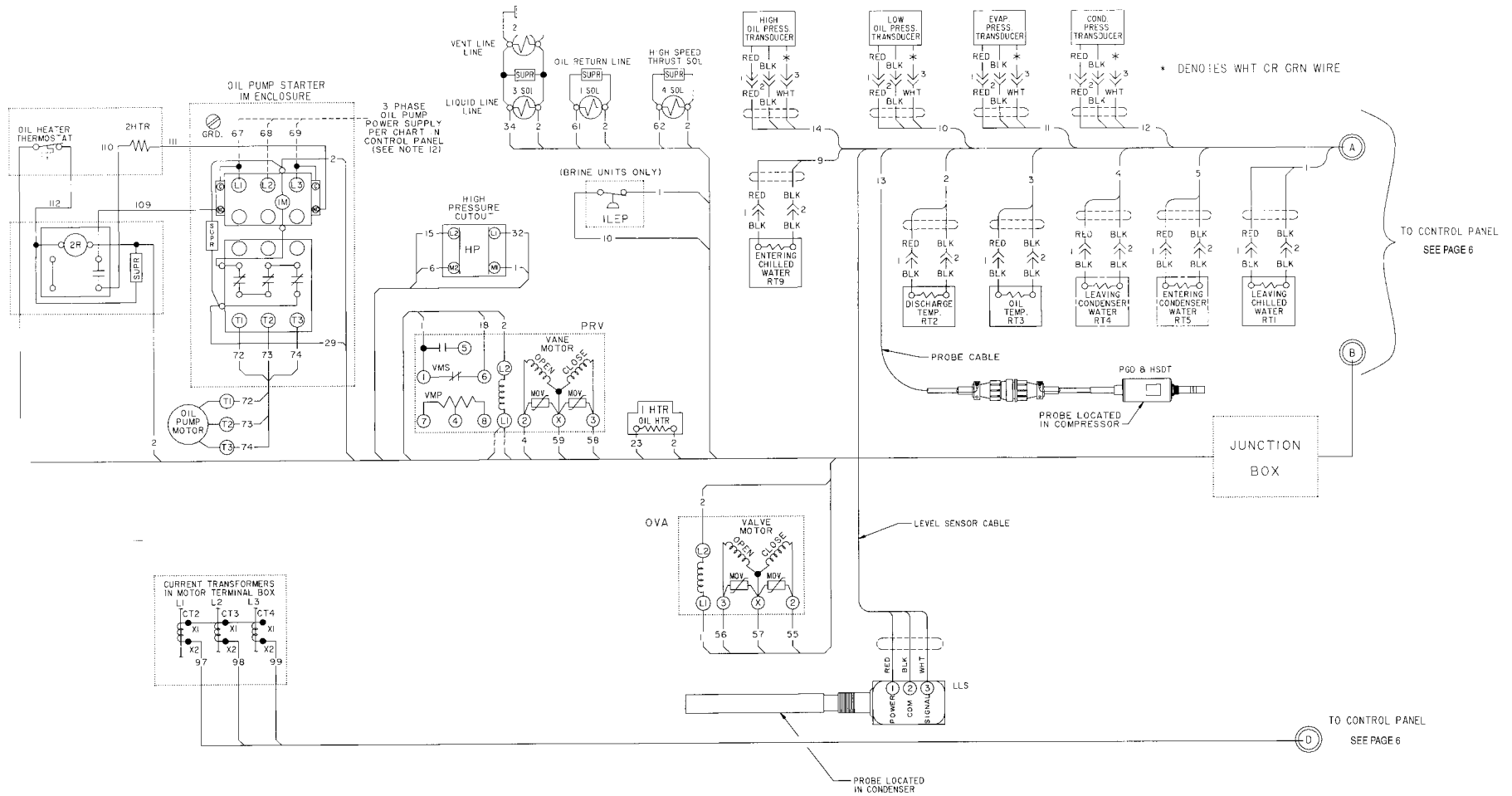

LD00821

| OIL PUMP MOTOR | | OIL PUMP STARTER OVERLOAD HEATERS | | | | |
|----------------|----------------|-----------------------------------|-------------------------|-----------|--------------------------------|--------------|
| VOLTS-PH-HZ | FULL LOAD AMPS | MANUFACTURER | MANUFACTURER'S PART NO. | TRIP AMPS | MAXIMUM DUAL ELEMENT FUSE SIZE | % PROTECTION |
| 200-3-60 | 7.2 | FURNAS | K49 | 9.80 | 30 | 136 |
| 208-3-60 | 6.8 | ↓ | K43 | 8.55 | 30 | 126 |
| 220-3-60 | 6.7 | | K43 | 8.55 | 30 | 128 |
| 230-3-60 | 6.7 | | K43 | 8.55 | 30 | 128 |
| 240-3-60 | 6.7 | | K43 | 8.55 | 30 | 128 |
| 380-3-60 | 3.9 | | K34 | 5.02 | 15 | 129 |
| 416-3-60 | 3.4 | | K33 | 4.67 | 15 | 137 |
| 440-3-60 | 3.35 | | K32 | 4.23 | 12 | 126 |
| 460-3-60 | 3.35 | | K32 | 4.23 | 12 | 126 |
| 480-3-60 | 3.4 | | K33 | 4.67 | 15 | 137 |
| 550-3-60 | 2.6 | | K29 | 3.61 | 10 | 139 |
| 575-3-60 | 2.6 | | K29 | 3.61 | 10 | 139 |
| 600-3-60 | 2.7 | | K29 | 3.61 | 10 | 134 |
| 346-3-50 | 3.9 | | K34 | 5.02 | 15 | 129 |
| 380-3-50 | 3.4 | | K33 | 4.67 | 15 | 137 |
| 400-3-50 | 3.4 | | K33 | 4.67 | 15 | 137 |
| 415-3-50 | 3.6 | | K33 | 4.67 | 15 | 130 |
| 220-3-50 | 6.2 | | K42 | 8.05 | 25 | 130 |
| 440-3-50 | 3.1 | | K31 | 3.93 | 10 | 127 |



Proud Sponsor
of the 1998
U.S. Olympic Team

36USC380