



ES Service Information

File In/With: 160.54-M1

SI0155

New

3-07

Equipment Affected: YK Chillers

Microboard 031-02430-001

GENERAL

Beginning June 2006, new YK chillers and replacement parts kit 331-02430-601 will be supplied with Microboard part number 031-02430-001. This Microboard is an upgraded version of the present production 031-02430-000 microboard. The upgrade includes a larger BRAM (U38) and an additional RS-485 port on COM2 for Modbus serial communications protocol.

These upgrades are necessary to operate with the new Medium Voltage Solid State Starter (MV SSS) and Medium Voltage Variable Speed Drive (MV VSD), since these drives require RS-485 Modbus serial communications protocol to communicate with the microboard.

On new production Variable Speed Drives (VSD) after March 2007, the VSD-to-microboard Opto-coupled YORK protocol serial communications is replaced with RS-485 Modbus communications. This new microboard is required in these applications. With the VSD Modbus applications, the Adaptive Capacity Control (ACC) functionality is contained in the microboard and the ACC Board is not used.

This upgraded board is backward compatible with existing YK chillers using the 031-02430-000 or 031-01730-000 microboard. With the exception of the changes below, this new board operates the same as previous boards.

BRAM

The part number of the BRAM in microboard 031-02430-001 is 031-02565-000 and its size is 128KB. It is installed in a 32-pin socket. Program Jumper JP14 is a removable 2-pin shunt type jumper. The 128KB BRAM requires the shunt be NOT INSTALLED and the board is supplied in this configuration. If the shunt is installed on JP14, it would apply DC power to an incorrect pin on the 128KB BRAM and the board would not function. The 128KB BRAM is required for MV SSS, MV VSD and VSD Modbus applications. The 128KB BRAM requires software that has "BRAM size detect" capability. If it does not have this capability, the board will not function. YK chiller software version C.OPT.01.15.xxx (and later) has this capability and is required.

The part number of the BRAM in microboard 031-02430-000 is 031-02431-000 and its size is 32KB. It is installed in a 28-pin socket. Program Jumper JP14 is a non-removable (soldered) wire jumper that connects DC power to the appropriate pin on the BRAM for 32KB operation.

COM2 SERIAL PORT

The 031-02430-001 microboard has two selectable serial modes for COM2. It can operate in either RS-232 or RS-485 mode, depending on the position of program Jumper JP17 as follows:

- JP17 on pins 1 & 2 – RS-485 mode (required for MV SSS, MV VSD & VSD Modbus operation)
- JP17 on pins 2 & 3 – RS-232 mode

The 031-02430-000 microboard contains a single RS-232 port for COM2.

SOFTWARE REQUIREMENT

The 031-02430-001 microboard is supplied with a 128KB BRAM (031-02565-000). In this configuration, software version C.OPT.01.15.xxx (and later) is required. It will not function with previous software versions.

For MV SSS applications, software version C.OPT.01.15.xxx (or later) is required.

For MV VSD and VSD Modbus applications, software version C.OPT.01.16.xxx (or later) is required (not available until after March 2007).

If this board is being used in applications other than MV SSS, MV VSD or VSD Modbus, the 32KB BRAM (031-02431-000) from a 031-02430-000 microboard can be transferred to the 031-02430-001 microboard (using the procedure below) to retain stored BRAM data. In this configuration, software versions prior-to or later-than C.OPT.01.15.xxx can then be used.

MICROBOARD 031-02430-001/ 031-02430-000 COMPARISON

	<u>031-02430-000</u>	<u>031-02430-001</u>
BRAM	031-02431-000 (32KB)	031-02565-000 (128KB)
BRAM Socket	28 pin	32 Pin
Program Jumper JP14	Non-removable wire	2-pin shunt type w/shunt removed
COM2 Serial Port	RS-232	RS-232 or RS485 as selected w/JP17 RS-485 required for MV SSS, MV VSD, VSD Modbus
Required Software	Any version	C.OPT.01.15.xxx or later (see BRAM transfer exception below). MV VSD & VSD Modbus require C.OPT.01.16.xxx or later.
Application	All except MV SSS, MV VSD, VSD Modbus	All. including MV SSS, MV VSD, VSD Modbus

TRANSFERRING A 32KB BRAM FROM 031-02430-000 BOARD TO 031-02430-001 BOARD

For applications other than MV SSS, MV VSD or VSD Modbus, the 32KB BRAM (031-02431-000) from a 031-02430-000 microboard can be transferred to the 031-02430-001 microboard. This can be useful when it is desired to transfer a BRAM from one board to another to save stored setpoint, History or Sales Order data.

To transfer the BRAM, perform the following:

1. Install a shunt over Program Jumper JP14. Use an unused black plastic shunt from JP9-JP12. (DO NOT USE JP1).
2. Install 32KB BRAM toward bottom of the BRAM socket (U38) so that there are 4 empty sockets at the top of the BRAM socket as shown.

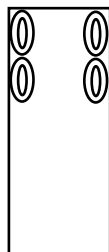

3. With this configuration, the board can be operated with software versions prior to or later than version C.OPT.01.15. xxx.

SERIAL COMMUNICATIONS WITH VARIABLE SPEED DRIVES AND SOLID STATE STARTERS

MV VSD AND MVSSS

The 031-02430-001 microboard communicates with the Medium Voltage Solid State Starter (MV SSS) and Medium Voltage Variable Speed Drive (MV VSD) using the COM2 (J13) RS-485 port with Modbus protocol (ref FIG. 1). On the SETUP Screen, select either “MV SSS” or “MV VSD”, as appropriate, for the Motor Drive Type

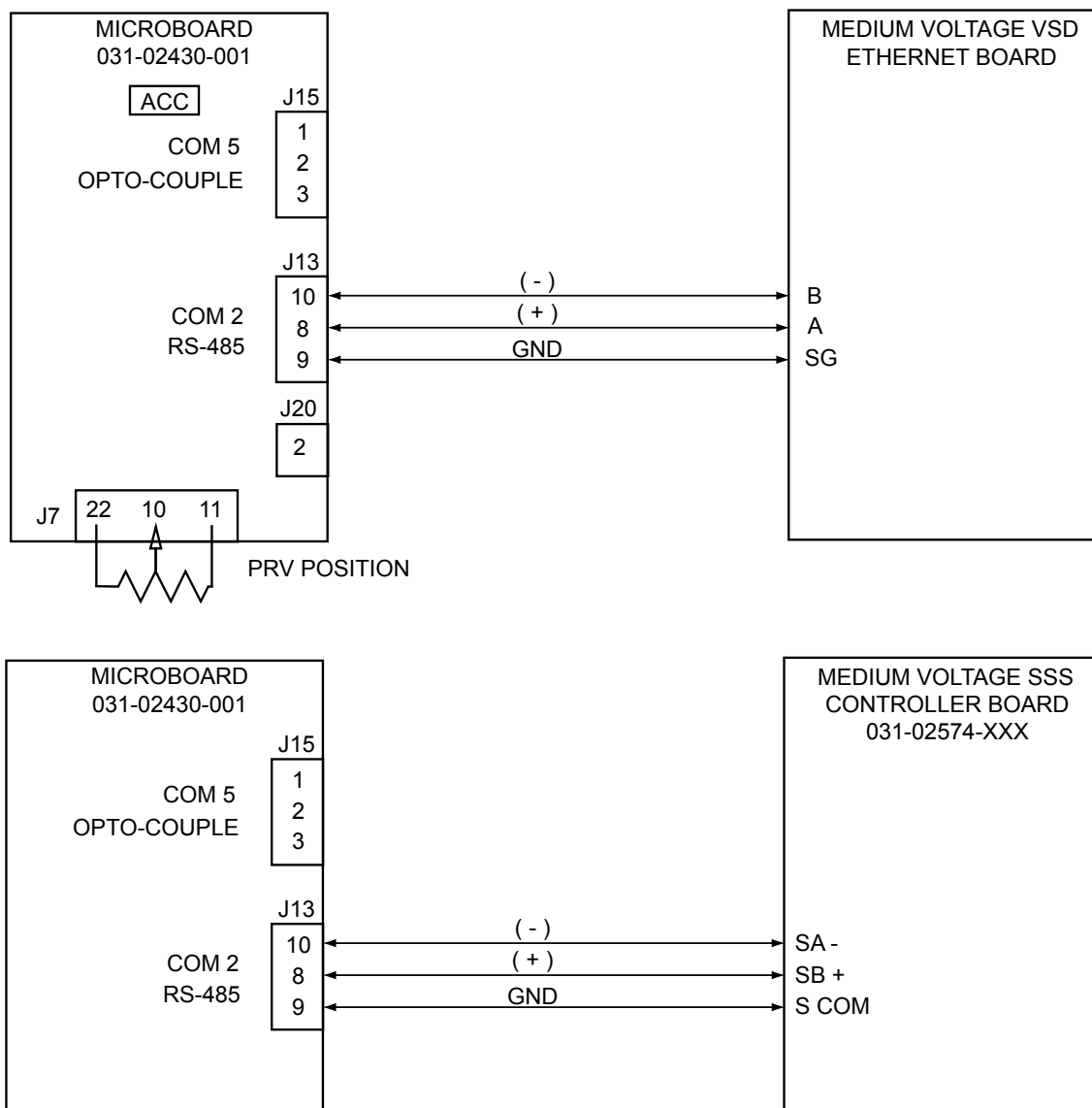

FIG. 1 - MEDIUM VOLTAGE DRIVE SERIAL COMMUNICATION (MODBUS PROTOCOL)

Variable Speed Drives

On new production chillers prior to June 2006, Microboard 031-01730-000 or 031-02430-000 COM5 serial port (J15) communicates with the Adaptive Capacity Control Board using YORK protocol. The COM5 serial port is retained on the 031-02430-001 microboard to allow it to be used as service replacement for these applications (ref

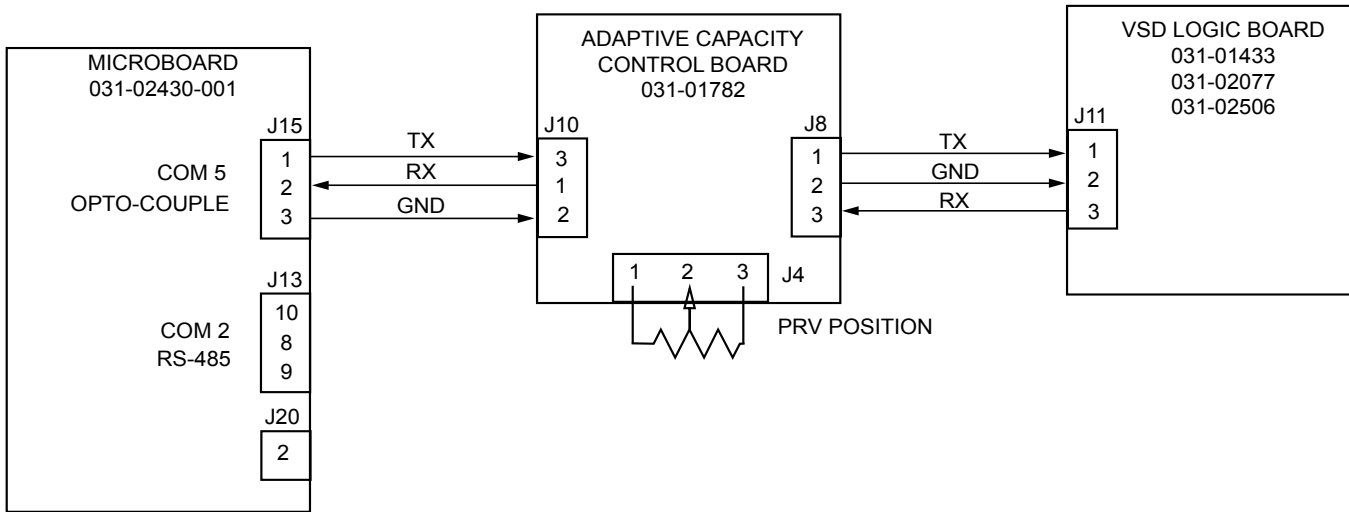

FIG. 2 - VARIABLE SPEED DRIVE SERIAL COMMUNICATION (YORK PROTOCOL)

FIG. 2).

On new production chillers between June 2006 and March 2007, microboard 031-02430-001 COM5 serial port (J15) communicates with the Adaptive Capacity Control Board using YORK protocol (ref FIG. 2).

On new production chillers after March 2007, the 031-02430-001 microboard COM2 (J13) serial port communicates directly with VSD Logic Board 031-02506 using RS-485 Modbus protocol (ref FIG. 3). Software version C.OPT.01.16.xxx (or later) is required for COM2 Modbus operation. With the VSD Modbus protocol, the Adap-

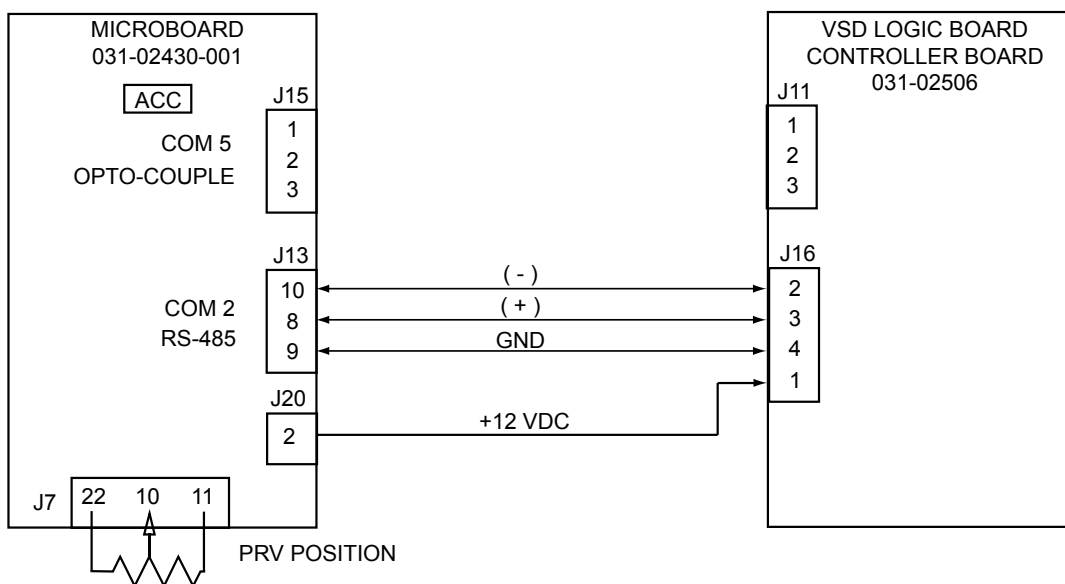

FIG. 3 - VARIABLE SPEED DRIVE SERIAL COMMUNICATION (MODBUS PROTOCOL)

With software version C.OPT.01.16.xxx (or later), when VSD-50Hz or VSD-60Hz is selected for the Motor Drive Type setpoint on the SETUP Screen, the Motor Communications Protocol Setpoint must be set to either “YORK” or “MODBUS” as appropriate. If “MODBUS” is selected, the “MOTOR NODE ID” setpoint must be set to “1” to match the VSD Logic Board Modbus address Switch SW3, which is also set to “1”.

Solid State Starters

On new production chillers prior to June 2006, microboard 031-01730-000 or 031-02430-000 COM5 serial port (J15) communicates with the LCSSS Logic/Trigger Board 031-02001 using YORK protocol (ref FIG. 4). The COM5 serial port is retained on the 031-02430-001 microboard to allow it to be used as service replacement for these applications (ref FIG. 4).

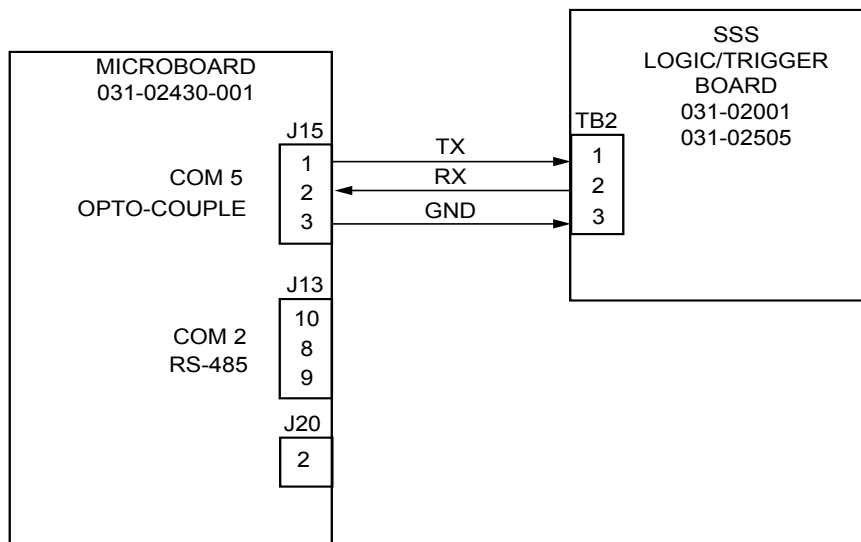

FIG. 4 - STYLE "B" SOLID STATE STARTER SERIAL COMMUNICATION (YORK PROTOCOL)

On new production chillers after June 2006, Microboard 031-02430-001 COM5 Serial Port (J15) communicates with the LCSSS Logic/Trigger Board 031-02001 using YORK protocol (ref FIG. 4). Later in 2007, it will communicate with Logic/Trigger Board 031-02505 using the same interface/protocol.