



BY JOHNSON CONTROLS

Service Information

File In/With: N/A

SI0240

New 511

Equipment Affected: YK, YD, YST, and CYK Chillers with PRV and VGD Actuators

TROUBLESHOOTING YK, YD, YST, AND CYK CHILLER PRV AND VGD ACTUATORS



It is mandatory that the technician performing these troubleshooting procedures be familiar with all Johnson Controls safety policy and practices for troubleshooting electrical devices. If not, do not attempt to troubleshoot the device discussed in this Service Information Letter. When power is applied to the control panel, 120 vac is present at the actuator terminal block.

INTRODUCTION

The scope of this Service Information Letter assumes the technician is familiar with the YORK control panel/unit being tested and is able to perform the necessary procedures to manually drive the actuators open and closed for preliminary testing from the control panel. This requires familiarity with the specific unit control panel operation that is not in the scope of this instruction. Reference the specific equipment Operations Manual if needed.

This instruction provides the testing procedures that can be used to isolate a defective actuator from a hardware malfunction in the control panel, or a mechanical malfunction of the compressor PRV or VGD mechanical assembly.

It should be noted that the “Actuator Operation Sequence Summary” detailed in this Service Information Letter provides an operating example using the PRV actuator and makes reference to specific terminal block numbers for that purpose. The VGD actuator operation would be similar; however the terminal block connections on the control panel I/O board are different than the PRV actuator.

OVERVIEW

These procedures apply to the YK, YD, YST, and CYK Centrifugal chiller compressor PRV and VGD actuators. There are five actuators with specific torque values; 200 in. lb., 450 in. lb., 800 in. lb., 1100 in. lb., and 1875 in. lb. It is important to note the 1875 in. lb. actuator requires a different troubleshooting procedure from the other actuator. The 1875 in. lb. actuator uses 120 vac on the open and close inputs to drive the actuator open or closed.

Work on this equipment should only be done by properly trained personnel who are qualified to work on this type of equipment. Failure to comply with this requirement could expose the worker, the equipment and the building and its inhabitants to the risk of injury or property damage.

The instructions on this service bulletin are written assuming the individual who will perform this work is a fully trained HVAC & R journeyman or equivalent, certified in refrigerant handling and recovery techniques, and knowledgeable with regard to electrical lock out/tag out procedures. The individual performing this work should be aware of and comply with all Johnson Controls, national, state and local safety and environmental regulations while carrying out this work. Before attempting to work on any equipment, the individual should be thoroughly familiar with the equipment by reading and understanding the associated service literature applicable to the equipment. If you do not have this literature, you may obtain it by contacting a Johnson Controls Service Office.

Should there be any question concerning any aspect of the tasks outlined in this bulletin, please consult a Johnson Controls Service Office prior to attempting the work. Please be aware that this information may be time sensitive and that Johnson Controls reserves the right to revise this information at any time. Be certain you are working with the latest information.



The 1875 in. lb. actuators require a different troubleshooting procedure. The 1875 in. lb. actuator uses 120 vac to drive the actuator open (CW) or closed (CCW). Failure to follow the correct procedure may result in injury, death, and equipment damage or incorrect interpretation of actuator operation.

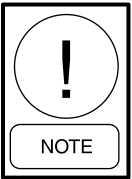

The actuator position in this instruction will always be in reference to the actuator base being base down and parallel to the floor when referencing the 3 o' clock and 9 o' clock positions.

Example: The actuators mounted on the compressor below shows the 9 o'clock position that will be referenced in the troubleshooting procedure. Note the 9 o'clock position on the PRV and VGD actuator is relative to the actuator base being referenced when parallel to the floor.

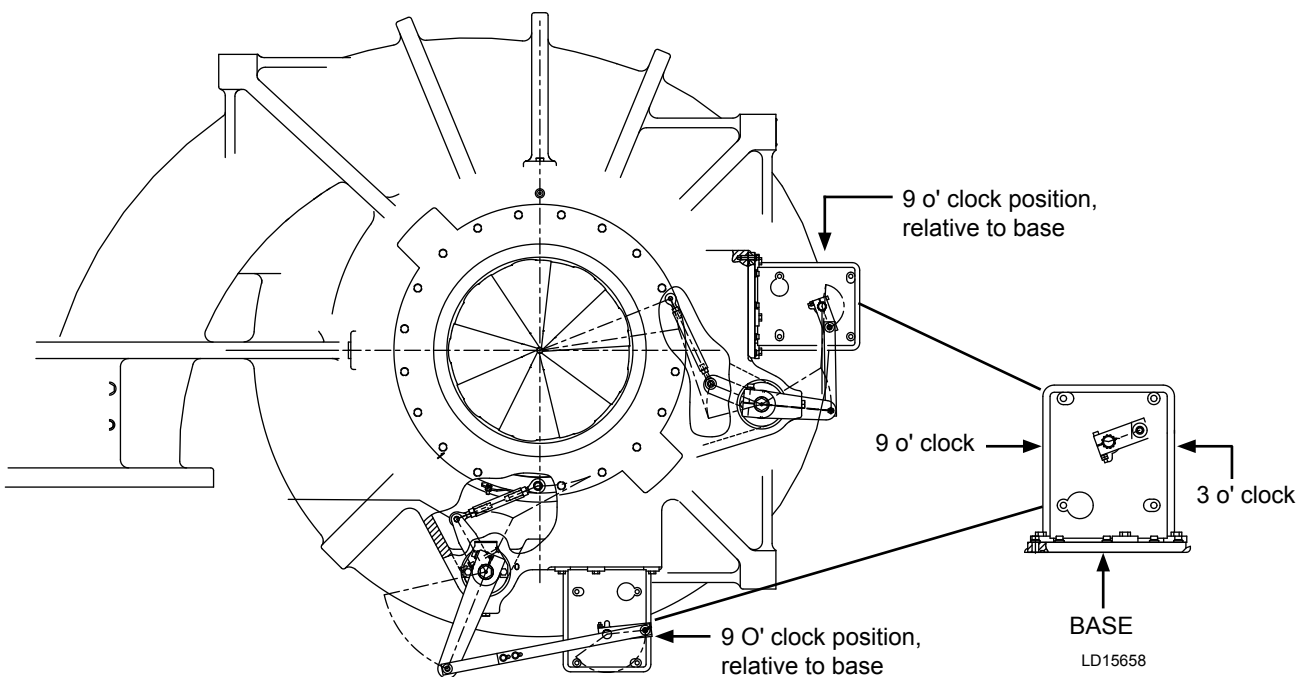

FIGURE 1 - ACTUATOR ORIENTATION

All reference to open and close are as viewed looking at the shaft end of the actuator. Open is a clockwise rotation (CW) of the shaft, and close is a Counter-Clockwise rotation (CCW) of the shaft. See Figure 2 below.

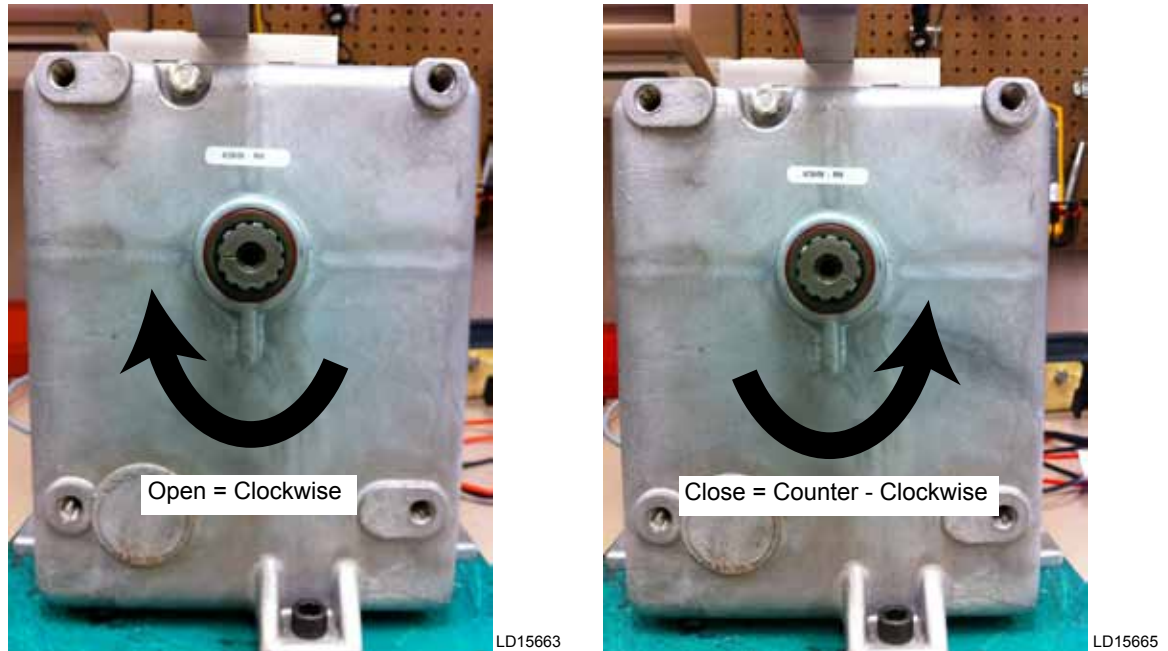
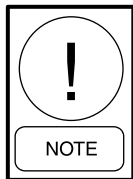

FIGURE 2 - ACTUATOR SHAFT ROTATION

ACTUATOR OPERATION SEQUENCE SUMMARY (EXCLUDING 1875 IN. LB. ACTUATOR)



The following explanations are given using a Pre-rotation vane motor actuator as the example. Except where noted, the Pre-rotation Vane (PRV) actuator and Variable Geometry Diffuser (VGD) actuator operate the same with regard to the actuator terminal block connections. As a result, the troubleshooting procedure will be the same as described in this document for both the PRV actuator and VGD actuator. The I/O board connections in the respective chiller control panel use separate terminal connections and will have different terminal designs.

Actuator Terminals L1 and L2

Referencing Figure 3 on page 4 and Figure 4 on page 4 of this document, 120 vac is supplied to actuator terminals L1 (120 vac “hot”) and L2 (120 vac “common”) and is the power source for the actuator. When power is applied to the control panel, 120 vac will be present on terminals L1 and L2 through a fuse or circuit breaker.

Actuator Terminals X, 2, and 3

Driving the actuator in the open direction (CW) - Referencing Figure 3 and Figure 4, terminal X is the “common” connection for the open and close windings on the actuator terminal block. When the micro board is commanding the vanes to open, a triac on the I/O board will turn ON, effectively shorting terminals 59 and 3 on the I/O board. Notice that it is also effectively “shorting” terminals X to 2 in the actuator, which will drive the actuator in the open direction.

Driving the actuator in the closed direction (CCW) - Referencing Figure 3 and Figure 4, terminal X is the “common” connection for the open and close windings on the actuator terminal block. When the micro board is commanding the vanes to close, a triac on the I/O board will turn ON, effectively shorting terminals 59 and 58 on the I/O board. Notice that it is also effectively “shorting” terminals X to 3 in the actuator, which will drive the actuator in the closed direction.

It is important to note that when driving the vanes open and closed for this type of actuator, that no voltage is being applied to the open (terminal 2) or closed (terminal 3) terminal on the actuator terminal block. Driving the actuator open or closed consists only of shorting either the open terminal (terminal 2) or closed terminal (terminal 3) to the X terminal on the actuator terminal block.

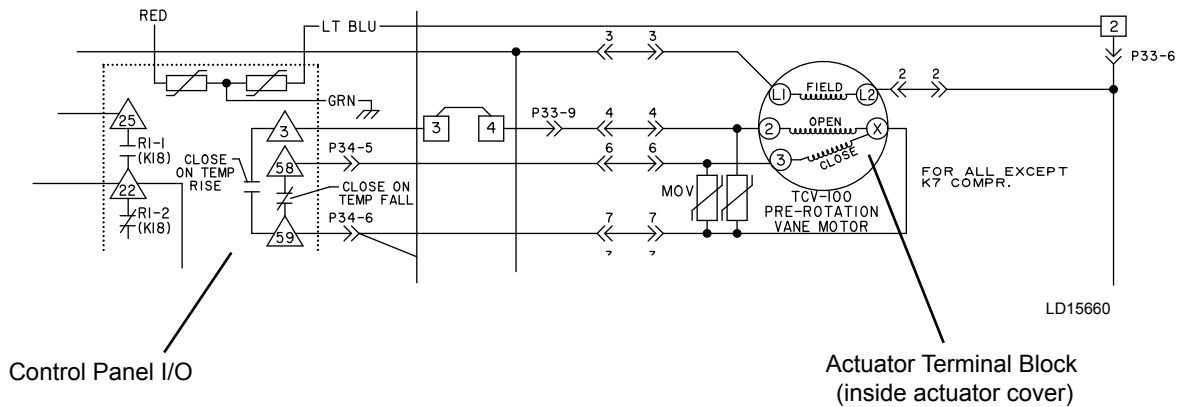

FIGURE 3 - ACTUATOR MOTOR TERMINAL BLOCK WIRING TO CONTROL PANEL I/O BOARD

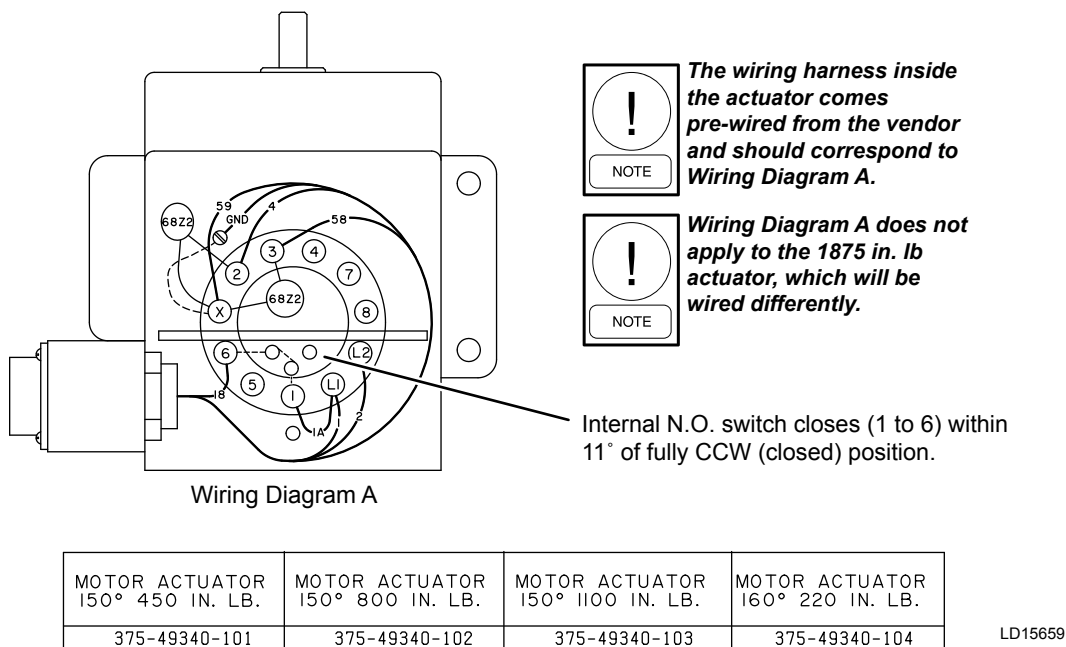
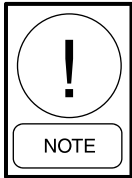

FIGURE 4 - WIRING DIAGRAM A

ACTUATOR OPERATION SEQUENCE SUMMARY 1875 IN. LB. ACTUATOR ONLY



The following explanations are given using a Pre-rotation vane motor actuator as the example. Except where noted, the Pre-rotation Vane (PRV) actuator and Variable Geometry Diffuser (VGD) actuator operate the same with regard to the actuator terminal block connections. As a result, the troubleshooting procedure will be the same as described in this document for both the PRV actuator and VGD actuator. However the I/O board connections in the respective chiller control panel use separate terminal connections and will have different terminal designations.

Actuator Terminals L1 and L2

Referencing Figure 5 on page 6 of this document, 120 vac common is supplied to the actuator motor actuator terminal L2. The L1 connection is 120 vac “hot” and connected via jumper wire 1A to terminal 1 for the VMS (or closed VGD) signal only. When power is applied to the control panel, 120 vac will be present on terminals L1 and L2 through a fuse or circuit breaker.

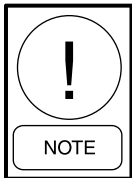

Wire number 59 is insulated and NOT connected to terminal X in this actuator – reference Wiring Diagram B on Figure 5.

Actuator Terminals 2 and 3

Driving the actuator in the open direction (CW) - Reference Figure 5. When the micro board is commanding the vanes to open, a triac on the I/O board will turn ON, supplying 120 vac “hot” to actuator terminal 2 on the actuator terminal block to drive the actuator open. **Notice that operation of the 1875 in. lb. actuator is the only actuator covered in this document that has 120 vac applied to terminal 2 on the actuator terminal block to drive the actuator.**

Driving the actuator in the closed direction (CCW) - Reference Figure 5. When the micro board is commanding the vanes to close, a triac on the I/O board will turn ON, supplying 120 vac “hot” to actuator terminal 3 on the actuator terminal block to drive the actuator closed. **Notice that operation of the 1875 in. lb. actuator is the only actuator covered in this document that has 120 vac applied to terminal 3 on the actuator terminal block to drive the actuator.**

Terminal L2 is the “common” connection for the open and close windings on the actuator terminal block.

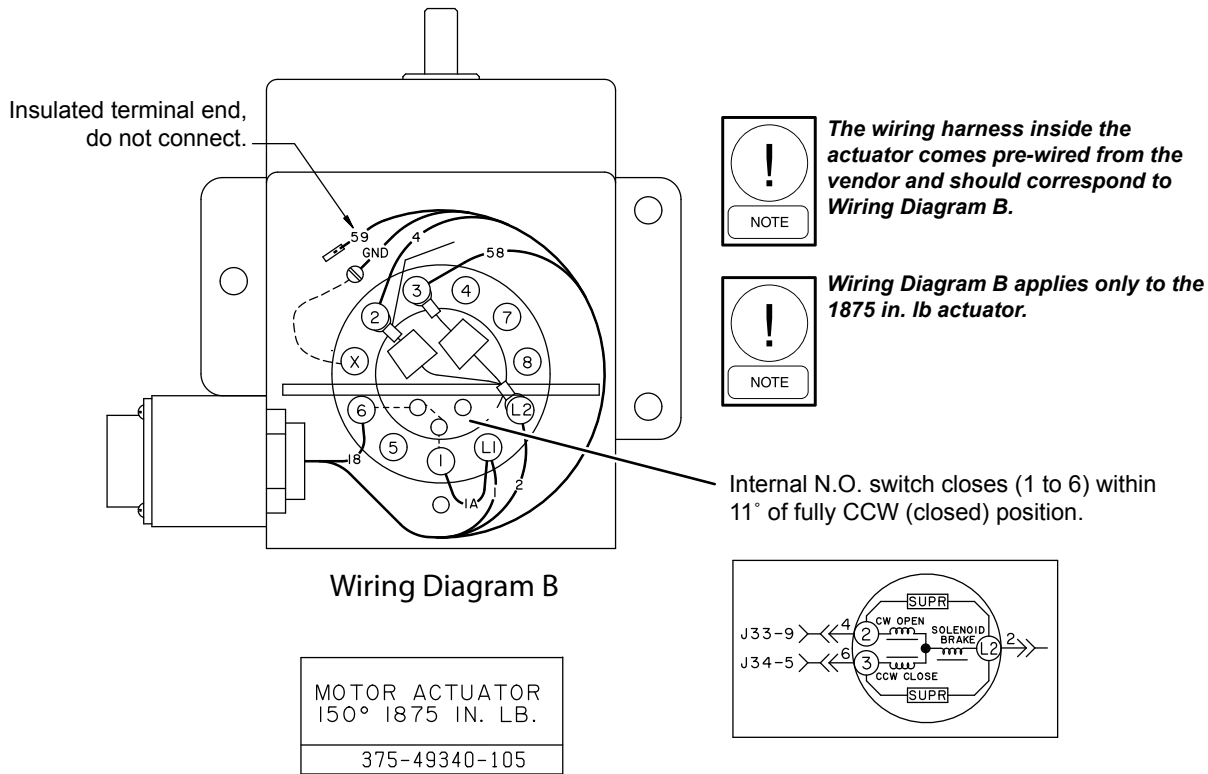

LD15666

FIGURE 5 - 1875 IN/LB ACTUATOR

ACTUATOR AUXILIARY CONTACTS AND FEEDBACK POTENTIOMETERS

Vane Motor Switch Operation (VMS)

The auxiliary contacts are internal Normally - Open (NO) contacts on terminal 1 to 6 on the actuator terminal block (reference Wiring Diagram A, Figure 4 on page 4 of this document, and Wiring Diagram B on Figure 5 above). Notice that terminal 1 has a jumper wire 1A to L1. L1 is supplying 120 vac to terminal 1. When the vane motor actuator shaft is within 11° of being fully closed (CCW), the auxiliary contacts 1 to 6 close, supplying a 120 vac signal to terminal 6, which would then be routed to the respective control panel to indicate that the vane motor/pre-rotation vanes are in the closed position. Reference Figure 6 on page 7

Variable Geometry Diffuser Switch (VGD)

On compressors that use a VGD, The auxiliary contacts are Normally open (NO) contacts on terminal 1 to 6 on the actuator terminal block (reference Wiring Diagram A, Figure 4 on page 4 of this document, and Wiring Diagram B on Figure 5 above). Notice that terminal 1 has a jumper wire (1A) to L1. The L1 terminal is supplying 120 vac to terminal 1. When the VGD actuator motor shaft is within 11° of being fully closed (CCW), the auxiliary contacts 1 to 6 close, supplying a 120 vac signal to terminal 6, which would then be routed to the respective control panel to indicate that the VGD is in the closed (extended) position. Reference Figure 6 on page 7.

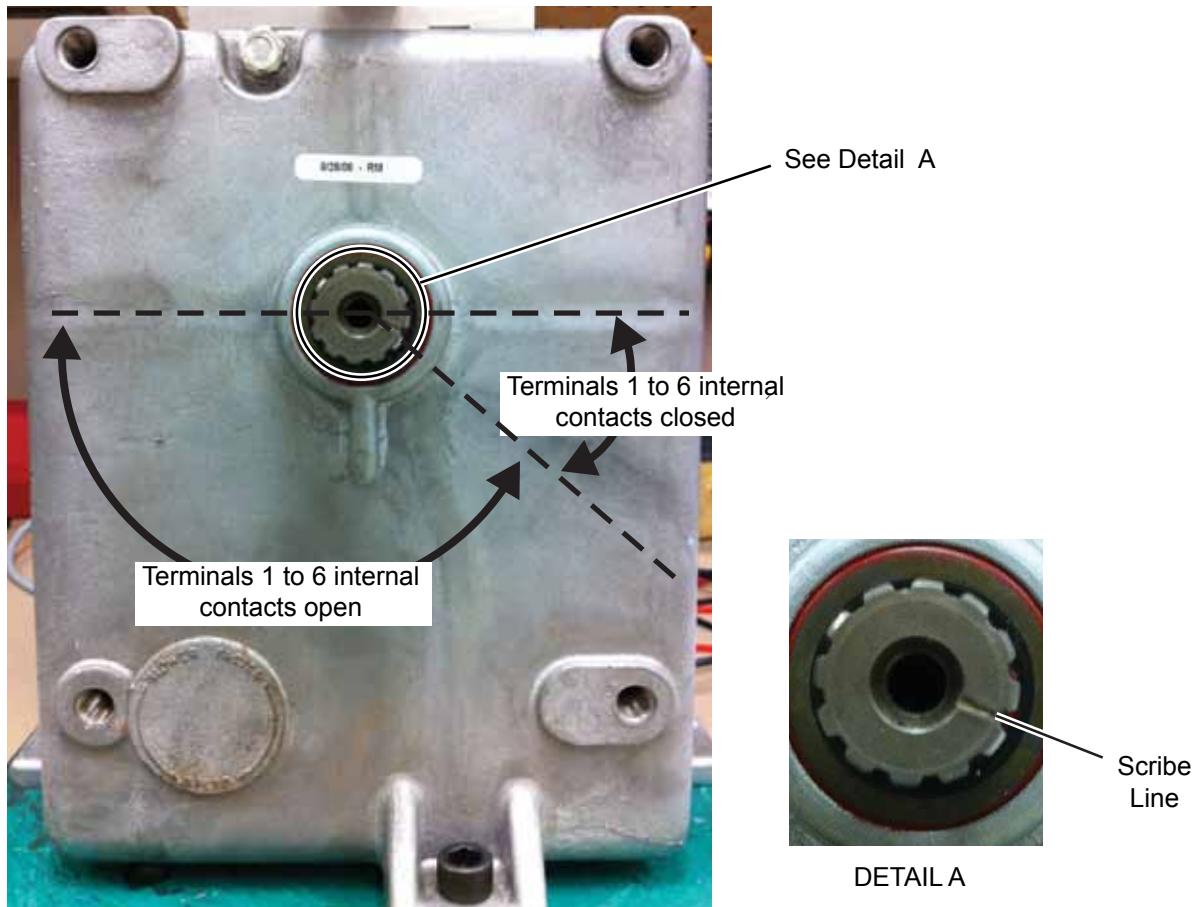

FIGURE 6 - VMS OR VGD SWITCH CLOSURE TERMINAL 1 TO 6

PRV Feedback Potentiometer

The PRV feedback potentiometer is an external 2500K ohm potentiometer that is external (not part of) to the actuator and not covered in the scope of this document.

VGD Feedback Potentiometer

The VGD feedback potentiometer is a 100 ohm potentiometer that is internal to the actuator. The actuator terminal block connections are on terminals 4, 7, and 8. **It is used exclusively on the CYK compound centrifugal chiller** and discussed in the troubleshooting section of this document.

TROUBLESHOOTING THE ACTUATORS



The VGD actuator base plate isolates the refrigerant system. NEVER remove the VGD actuator base plate when removing a VGD actuator from the compressor (reference Figure 7 below).

NEVER REMOVE VGD BASE PLATE WHEN REMOVING VGD ACTUATOR FROM THE COMPRESSOR WHEN THE SYSTEM IS CHARGED WITH REFRIGERANT OR PRESSURIZED.



LD15661

FIGURE 7 - VGD BASE PLATE

PRELIMINARY OPERATIONAL CHECKS TO VERIFY ACTUATOR OPERATION

1. With the unit shutdown and power applied to the control panel, use the **control panel manual controls** to stroke the actuator from fully open (CW) to fully closed (CCW). The actuator should stroke a nominal 150° to 160° as referenced on Figure 8 on page 9 and Figure 9 on page 9 of this document.
 - The Scribe Line or short tooth will be at the nominal position shown on Figure 8 when fully closed/CCW.
 - The Scribe line or short tooth on the shaft will be at the 9 o'clock position (shown in Figure 9) when fully open/CW.
2. The vane motor switch or VGD switch should show closed as observed on the unit control panel with the actuator in the fully closed position.
3. **CYK Only** – Verify that the “Pot Position” on the respective VGD screen on the control panel has a smooth % read-out as the VGD actuator strokes over its entire span from open to close, without any erratic read-out.

IF THE ACTUATOR FAILS THE PRELIMINARY OPERATIONAL CHECKS, THE ACTUATOR WILL NEED TO BE ISOLATED FROM THE CONTROL PANEL AND WIRING HARNESS TO VERIFY IF THE PROBLEM IS RELATED TO THE ACTUATOR.

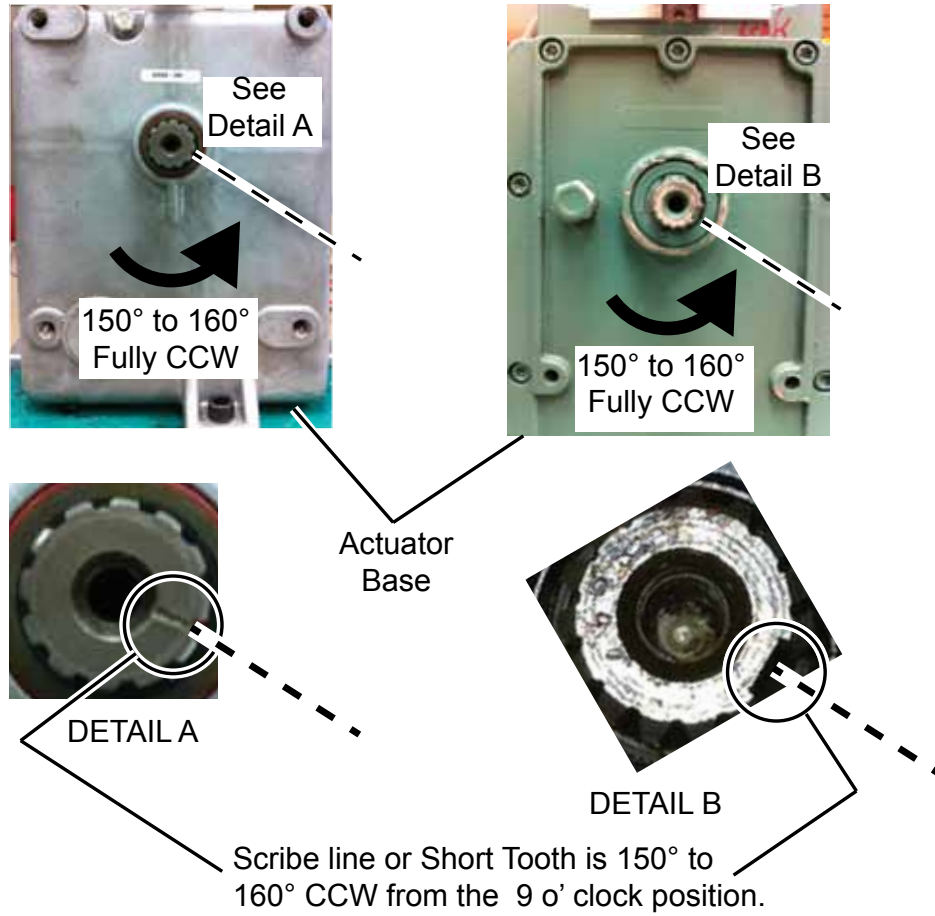

LD15669

FIGURE 8 - ACTUATOR DRIVEN TO FULLY CCW/CLOSED

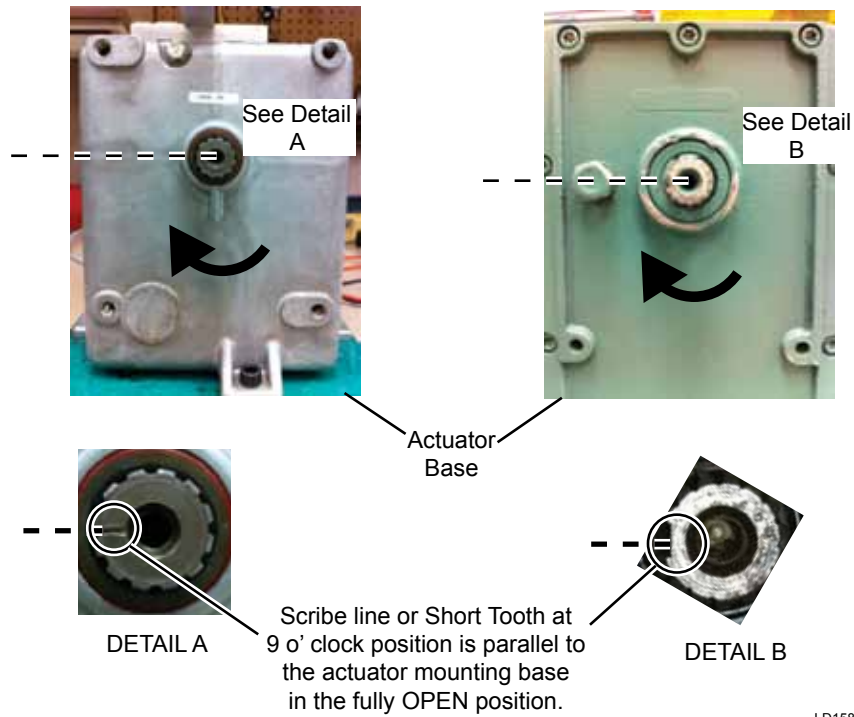

LD15886

FIGURE 9 - ACTUATOR DRIVEN TO FULLY CW/OPEN

TESTING THE ACTUATOR (EXCLUDING 1875 IN. LB. ACTUATOR)



The actuator terminal block wiring will have 120 vac present. Use proper safety procedures and PPE gear during testing



The 1875 in. lb. actuator requires a different troubleshooting procedure that is exclusive to the 1875 in. lb. actuator. The 1875 actuator uses 120 vac to drive the actuator open (CW) or closed (CCW). Failure to follow the correct procedure may result in injury, death, and equipment damage, or incorrect interpretation of correct actuator operation.

Access to troubleshoot the actuator may be limited due to the positioning of the actuator on the compressor. If so, the actuator should be removed from the compressor for testing.

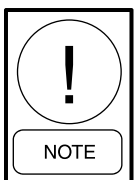

If the actuator needs to be removed from the compressor for testing, be sure to mark linkages and actuator shaft with reference lines for proper reassembly.

Review the entire actuator testing procedure prior to testing the actuator.

1. Reference Figure 4 on page 4 of this document.
2. Remove 120 vac from terminals L1 and L2 on the actuator terminal block.
3. Remove and isolate all wires from actuator terminal block. Note the wire numbers when removing from the terminal block - wiring should correspond to Figure 4 (Wiring Diagram A).
4. Connect 120 vac to actuator terminal block connections L1 and L2. The actuator motor shaft should not rotate.
If the shaft rotates, the actuator has failed.
5. Remove 120 vac from terminals L1 and L2 on the actuator terminal block. Jumper terminals X to 2 on the actuator terminal block. Connect 120 vac to terminals L1 and L2 on the actuator terminal block. Referencing Figure 9 on page 9 of this document, the scribe line or short tooth on the shaft should rotate Clockwise (viewed from the shaft end) to approximately the 9 o'clock position as shown. Note 9 o'clock position is in reference to the actuator base being parallel with the floor. **If the actuator does not rotate in the Clockwise direction to approximately the 9 o'clock position, the actuator has failed.**
6. Remove 120 vac from terminals L1 and L2 on the actuator terminal block. Remove the jumper wire used in step 5 from actuator terminals X to 2. Jumper terminals X to 3 on the actuator terminal block. Connect 120 vac to terminals L1 and L2 on the actuator terminal block. Referencing Figure 8 on page 9 of this document, the scribe line or short tooth on the shaft should rotate Counter-Clockwise (viewed from the shaft end) to approximately 150° to 160° from the fully open position as shown. **If the actuator does not rotate in the Counter-Clockwise direction to approximately the 150° to 160° position, the actuator has failed.**
7. Remove 120 vac from terminals L1 and L2 on the actuator terminal block. Remove the jumper wire from terminals X to 3 used in step 6. With the actuator in the fully Counter-Clockwise position, the internal switch should be closed as measured with an ohmmeter between terminals 1 and 6 on the actuator terminal block. **If the contacts are not closed between terminals 1 and 6, the actuator has failed.**

8. Jumper terminals X to 2 on the actuator terminal block. While monitoring continuity from terminals 1 to 6 on the actuator terminal block with an ohmmeter, connect 120 vac to terminals L1 and L2 on the actuator terminal block. Referencing Figure 6 on page 7, the scribe line or short tooth on the shaft should rotate Counter-Clockwise (viewed from the shaft end). Terminals 1 to 6 internal contacts should be closed in the area shown on Figure 6, then remain open for the remainder of the actuator Clockwise stroke. **If the contacts do not open or close in the areas shown on Figure 6, the actuator has failed.**
9. **CYK Units only** – Remove 120 vac from terminals L1 and L2. Using an ohmmeter, measure the actuator internal VGD potentiometer from terminals 7 to 8 on the actuator terminal block. The resistance should measure 100 ohms plus or minus 10%. **If the ohmmeter reads “shorted” or “open”, the actuator has failed.**

Ensure the actuator is driven to the fully clockwise position per step 5. From the fully open position, drive the actuator to the fully counter clockwise position per Step 6, while monitoring the VGD potentiometer resistance on terminals 4 to 7 with an ohmmeter. The ohm value should increase smoothly from approximately zero ohms to approximately 80 to 90 ohms over the entire stroke of the actuator. **If the ohm reading is erratic, “opens” or “shorts” anytime during the stroke the actuator has failed.**

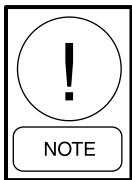

Analog meters are recommended for this test.

TESTING THE 1875 IN. LB. ACTUATOR



Terminals 2 and 3 operate with the application of 120 vac. The source of the 120 vac can be intermittent and comes from the control panel. Remove the 120 vac source by removing power from the control panel. Verify no voltage is present on these terminals before disconnecting or connecting the associated wiring/terminal connections.

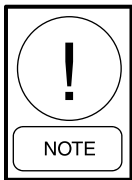

Wire number 59 is not used on this actuator – reference Figure 5 on page 6 of this document (Wiring Diagram B).

10. Reference Figure 5 in this document.
11. Remove 120 vac from the actuator terminal block. Reference Warning above.
12. Remove and isolate all wires from actuator terminal block. Note the wire numbers when removing from the terminal block (wiring should correspond to Figure 5 (Wiring Diagram B)).
13. Connect 120 vac neutral/common to actuator terminal block L2. Connect 120 vac “hot” to terminals 2 on the actuator terminal block. Referencing Figure 9 on page 9, the scribe line (or short tooth) on the shaft should rotate Clockwise (viewed from the shaft end) to approximately the 9 o'clock position as shown. Note 9 o'clock position is in reference to the base being parallel with the floor. **If the actuator does not rotate in the Clockwise direction to approximately the 9 o'clock position, the actuator has failed.**
14. Remove 120 vac from the actuator terminal block. Connect 120 vac neutral/common to terminal actuator terminal block L2. Connect 120 vac “hot” to terminals 3 on the actuator terminal block. Referencing Figure 8 on page 9, the scribe line or short tooth on the shaft should rotate Counter-Clockwise (viewed from the shaft end) to approximately 150° to 160° as shown. **If the actuator does not rotate in the Counter-Clockwise direction to approximately the 150° to 160° position, the actuator has failed.**

15. Remove 120 vac from the actuator terminal block. With the actuator in the fully Counter-Clockwise position, the internal switch should be closed as measured with an ohmmeter between terminals 1 and 6 on the actuator terminal block. **If the contacts are not closed between terminals 1 and 6, the actuator has failed.**
16. While monitoring continuity from terminals 1 to 6 on the actuator terminal block with an ohmmeter, connect 120 vac “hot” to terminal 2 and 120 vac “common” to L2 on the actuator terminal block. Referencing Figure 6 on page 7, the scribe line or short tooth on the shaft should rotate Counter-Clockwise (viewed from the shaft end). Terminals 1 to 6 internal contacts should be closed in the area shown on Figure 6, then remain open for the remainder of the actuator Clockwise stroke. **If the contacts do not open or close in the areas shown on Figure 6, the actuator has failed.**
17. **CYK Units only** – Remove 120 vac from terminals L1 and L2. Using an ohmmeter, measure the actuator internal VGD potentiometer from terminals 7 to 8 on the actuator terminal block. The resistance should measure 100 ohms plus or minus 10%. **If the ohmmeter reads “shorted” or “open”, the actuator has failed.**

Ensure the actuator is driven to the fully clockwise position per step 13. From the fully clockwise position, drive the actuator to the fully Counter-Clockwise position per Step 14, while monitoring the VGD potentiometer resistance on terminals 4 to 7 with an ohmmeter. The ohm value should increase smoothly from approximately zero ohms to approximately 80 to 90 ohms over the entire stroke of the actuator. **If the ohm reading is erratic, “opens” or “shorts” anytime during the stroke the actuator has failed.**

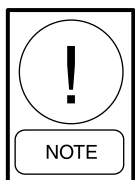

Analog meters are recommended for this test.