	Form Number: 160.49-M3 (LS03)	1108
	Supersedes: None	
LITERATURE SUPPLEMENT	File with: 160.49-M3 (1205)	
Subject: New Compressor Tool Kit available for P7 w/ VGD (YDHE-52)		

GENERAL

A New Compressor Tool Kit (364-51908-000) is now available for the P7 w/VGD (YDHE-52) which provides special tools and parts for the Compressor and VGD.

SPECIAL TOOLS

Special tools are available and will be furnished when ordered. These tools and parts are listed in the following Table.

P7 W/ VGD COMPRESSOR TOOL KIT (364-51908-000)

ITEM #	DESCRIPTION	YORK PART #	QTY.
1	Tool, Gear Locking/Coupling Puller	364-48023-000	1
2	Hhcs, .500-13 x 2.5 Gr 5 Zn	021-14249-000	2
3	Washer, PLain 17/32 Id x 1-1/16	021-01276-000	14
4	Nut, Heavy 1/2-13	021-02860-000	2
5	Pin, Guide 10-24Unc x 6-1	064-46488-000	2
6	Bolt, Eye 3/8-16Unc x 6-1	021-13498-000	3
7	Washer, Plain 13/32 Id x 13/16	021-05167-000	39
8	Pin, Guide 1/4-20Unc x 8 L	064-46499-000	2
9	Hook Tool	064-46610-000	2
10	Pin, Guide 3/8-16Unc x 7-1	064-18716-000	2
11	Stud, Spl .500-20 Unf	064-14500-000	1
12	Nut, Hex Hvy 1/2-20 Unf	021-00483-000	2
13	Bolt, Eye 7/8	021-07703-000	1
14	Washer, Plain 15/16 Id x 1-3/4	021-05158-000	2
15	Ring, VGD Alignment Tool	064-51706-000	1
16	Pin, Alignment 1/4 x 3.25 Lg	064-51887-000	3
17	Washer, Coupling	064-51818-000	1
18	Tool, Bushing Driver	064-52128-000	1
19	Washer, Special Bushing Driver	064-52129-000	1
20	Tool, Bushing Driver	064-52130-000	1
22	Sleeve, Bushing Driver	064-52383-000	1
23	Tool, Bushing Driver	064-52131-000	1

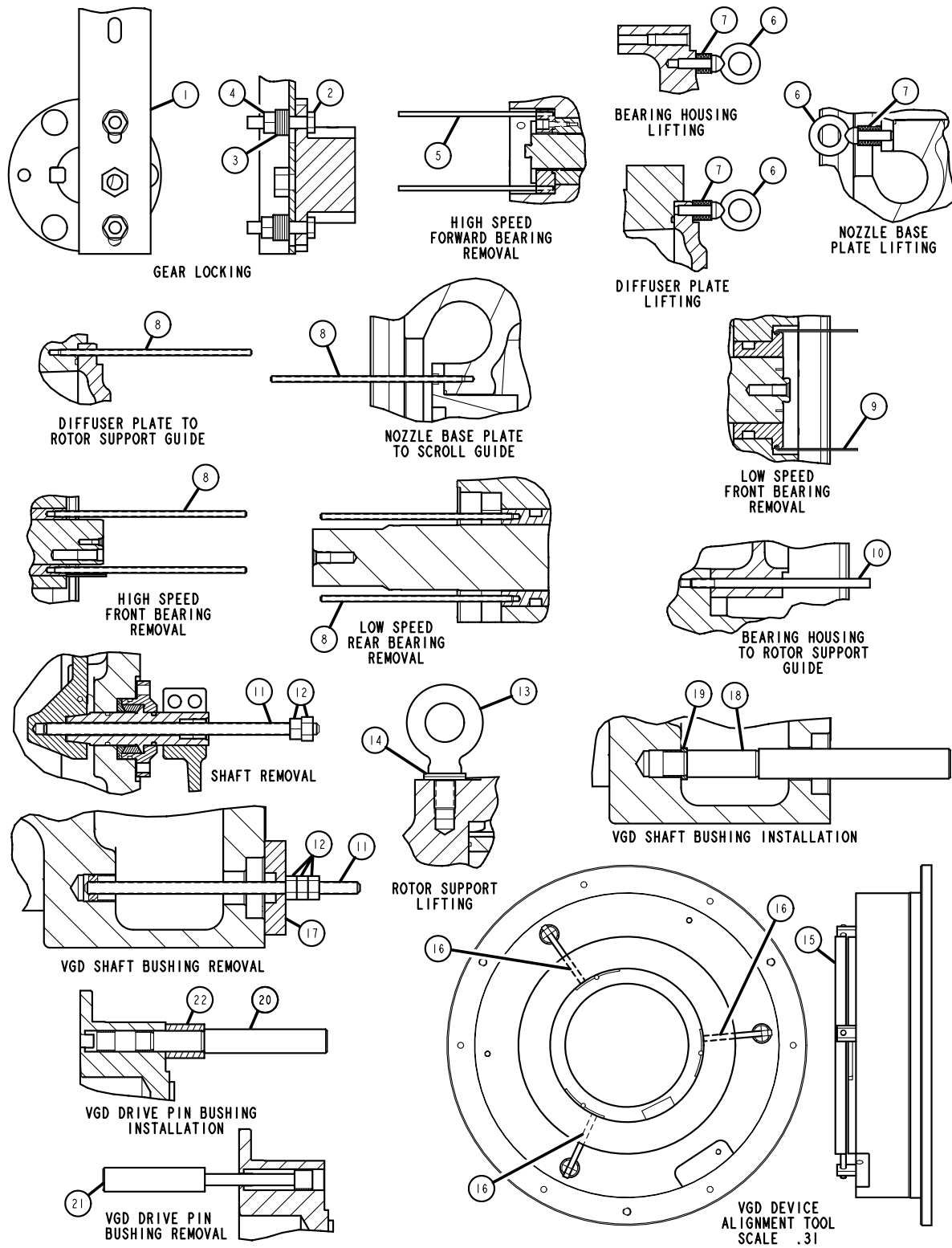

FIG. 1 – COMPRESSOR TOOL KIT (P7 W/ VGD)



P.O. Box 1592, York, Pennsylvania USA 17405-1592
 Copyright © by Johnson Controls 2008
 Form 160.49-M3 (LS03)
 New Release

Tele. 800-861-1001
 www.york.com

Subject to change without notice. Printed in USA
 ALL RIGHTS RESERVED