



Form Number: 160.49-M3 (LS02)

1207

Supersedes: None

LITERATURE SUPPLEMENT

File with: 160.49-M3 (1205)

Subject: Instructions to install a new eye seal in H9 compressors.

## EYE SEAL REPLACEMENT

1. Verify the Eye Seal configuration. If the OLD style as detailed in FIG. 1, a kit (YORK P/N 364-52107-000) will be required to change out the Eye Seal to the NEW design. Follow the attached service instructions to complete the change-out.
2. If the NEW style is used as detailed in FIG. 1, a NEW style Eye Seal (YORK P/N 064-52100-000) will be required. Follow the instructions provided in 160.49-M3 (1205) to complete the replacement.

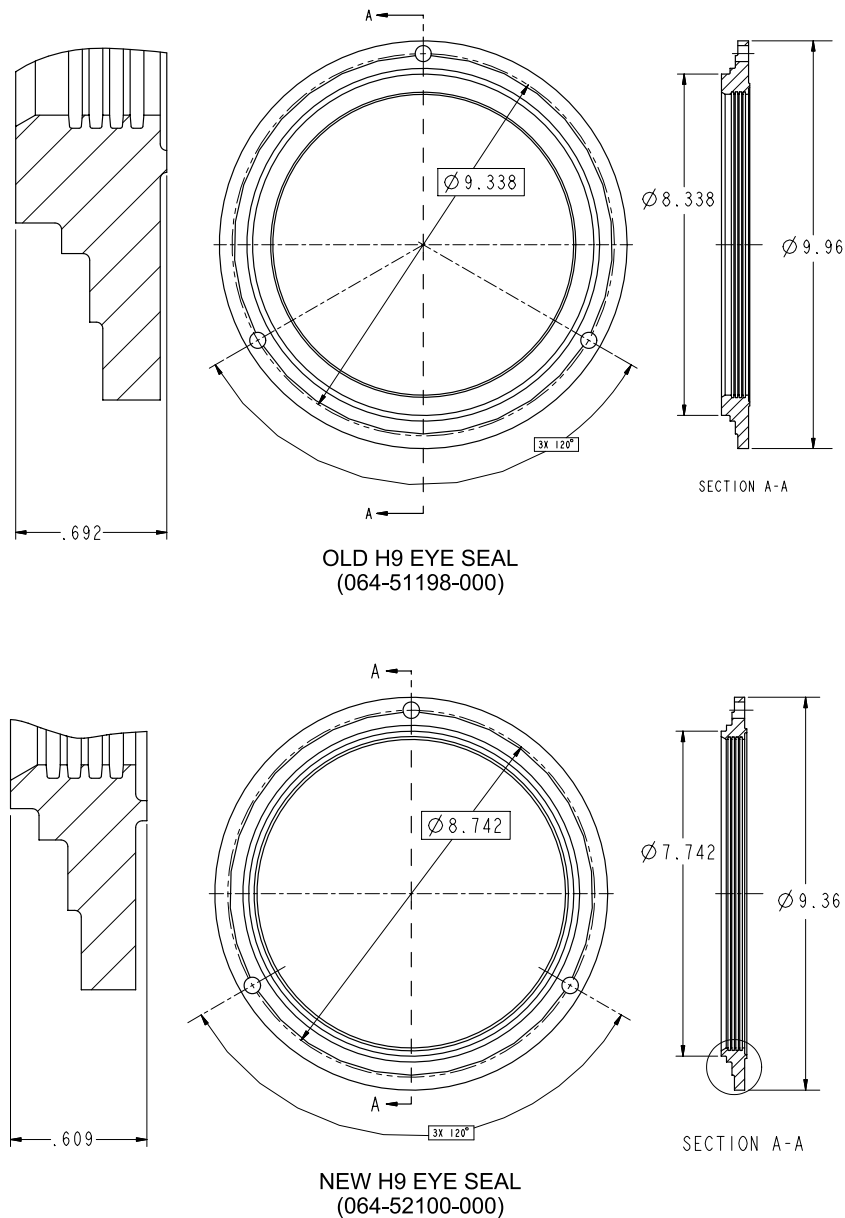
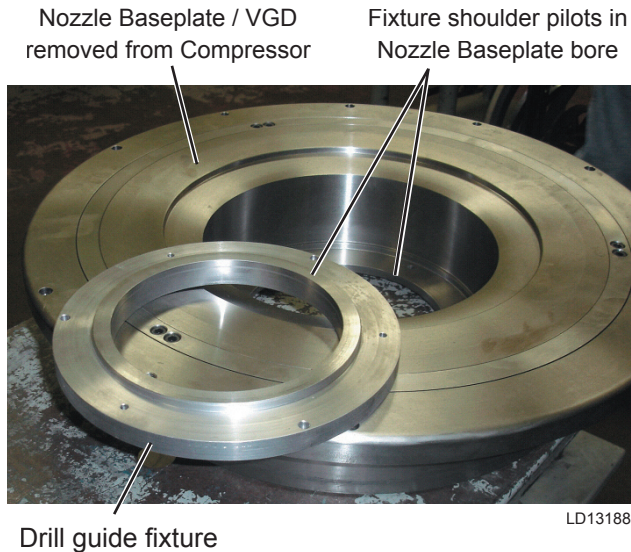

FIG. 1 - H9 EYE SEAL COMPARISON

## INSTRUCTIONS TO INSTALL NEW EYE SEAL IN H9 COMPRESSOR

1. Remove the nozzle baseplate/VGD. Remove the existing seal assembly.



**FIG. 2 - NOZZLE BASEPLATE**

2. Install the drill guide fixture into the 7.534" diameter bore in the nozzle baseplate. Shoulder of the fixture will pilot in bore. Secure the drill guide fixture to the nozzle using the three screws (supplied in the kit).



**FIG. 3 - DRILL GUIDE/FIXTURE INSTALLED**

3. Using a #7 drill bit (supplied in kit), drill three new seal mounting holes through the nozzle baseplate.



**FIG. 4 - DRILLING NEW HOLES**

4. Remove all metal debris using a vacuum. Do NOT use compressed air as chips may be blown into the VGD mechanism. Remove drill guide fixture.



**FIG. 5 - REMOVE METAL DEBRIS**

- Using a 1/4-20 tap (provided in kit), tap the three drilled holes. Keep the tap perpendicular with the seal mounting surface. Deburr holes using extreme caution to not chamfer. Use extreme care not to damage any of the surface where the seal seats.



**FIG. 6 - TAP THE DRILLED HOLES**

LD13192

- Apply type 086 (AVV) or 277 Loctite (permanent / red) to the three 1/4-20 set screws and install in old seal mounting holes. Tighten screws flush or below seal mounting surface.



**FIG. 8 - TIGHTEN SET SCREWS**

LD13194

- Clean all parts. Apply Loctite primer (7649).



**SET SCREWS  
(SUPPLIED IN KIT)**

LD13193

**FIG. 7 - PRIMER/THREADLOCKER AND SET SCREWS**



CAUTION

*If sets screws protrude above surface they may limit or prevent seal movement.*

- Clean surfaces and install new seal assembly as per instructions on page 39 of 160.49-M3 (1205).



P.O. Box 1592, York, Pennsylvania USA 17405-1592  
Copyright © by Johnson Controls 2007  
Form 160.49-M3 (LS02)  
New Release

Tele. 800-861-1001  
[www.york.com](http://www.york.com)

Subject to change without notice. Printed in USA  
ALL RIGHTS RESERVED