



Supersedes: 155.21-W1 (110)

Form: 155.21-W1 (615)

**YIA MOD D SINGLE STAGE
STEAM / HOT WATER
WITH OPTIVIEW CONTROL PANEL
ABSORPTION CHILLERS**

WIRING DIAGRAMS

CONTRACTOR _____
ORDER NO. _____
JCI CONTRACT NO. _____
JCI ORDER NO. _____

PURCHASER _____
JOB NAME _____
LOCATION _____
ENGINEER _____

REFERENCE DATE _____

APPROVAL DATE _____

CONSTRUCTION DATE _____

JOB DATA:

YIA MODEL NO. _____ SERIAL NO. _____

NO. OF UNITS _____

Issue Date:
June 26, 2015



IMPORTANT!

READ BEFORE PROCEEDING!

GENERAL SAFETY GUIDELINES

This equipment is a relatively complicated apparatus. During rigging, installation, operation, maintenance, or service, individuals may be exposed to certain components or conditions including, but not limited to: heavy objects, refrigerants, materials under pressure, rotating components, and both high and low voltage. Each of these items has the potential, if misused or handled improperly, to cause bodily injury or death. It is the obligation and responsibility of rigging, installation, and operating/service personnel to identify and recognize these inherent hazards, protect themselves, and proceed safely in completing their tasks. Failure to comply with any of these requirements could result in serious damage to the equipment and the property in

which it is situated, as well as severe personal injury or death to themselves and people at the site.

This document is intended for use by owner-authorized rigging, installation, and operating/service personnel. It is expected that these individuals possess independent training that will enable them to perform their assigned tasks properly and safely. It is essential that, prior to performing any task on this equipment, this individual shall have read and understood the on-product labels, this document and any referenced materials. This individual shall also be familiar with and comply with all applicable industry and governmental standards and regulations pertaining to the task in question.

SAFETY SYMBOLS

The following symbols are used in this document to alert the reader to specific situations:



Indicates a possible hazardous situation which will result in death or serious injury if proper care is not taken.



Identifies a hazard which could lead to damage to the machine, damage to other equipment and/or environmental pollution if proper care is not taken or instructions and are not followed.



Indicates a potentially hazardous situation which will result in possible injuries or damage to equipment if proper care is not taken.

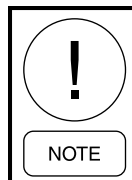

Highlights additional information useful to the technician in completing the work being performed properly.



External wiring, unless specified as an optional connection in the manufacturer's product line, is not to be connected inside the control cabinet. Devices such as relays, switches, transducers and controls and any external wiring must not be installed inside the micro panel. All wiring must be in accordance with Johnson Controls' published specifications and must be performed only by a qualified electrician. Johnson Controls will NOT be responsible for damage/problems resulting from improper connections to the controls or application of improper control signals. Failure to follow this warning will void the manufacturer's warranty and cause serious damage to property or personal injury.

CHANGEABILITY OF THIS DOCUMENT

In complying with Johnson Controls' policy for continuous product improvement, the information contained in this document is subject to change without notice. Johnson Controls makes no commitment to update or provide current information automatically to the manual or product owner. Updated manuals, if applicable, can be obtained by contacting the nearest Johnson Controls Service office or accessing the Johnson Controls QuickLIT website at <http://cgproducts.johnsoncontrols.com>.







It is the responsibility of rigging, lifting, and operating/service personnel to verify the applicability of these documents to the equipment. If there is any question

regarding the applicability of these documents, rigging, lifting, and operating/service personnel should verify whether the equipment has been modified and if current literature is available from the owner of the equipment prior to performing any work on the chiller.

CHANGE BARS

Revisions made to this document are indicated with a line along the left or right hand column in the area the revision was made. These revisions are to technical information and any other changes in spelling, grammar or formatting are not included.

LEGEND

1F	Refrigerant Level Switch
3F	Refrigerant Pump Cut-Out Level Switch
1M	3 Phase Solution Pump Starter (Mounted In Power Panel)
2M	3 Phase Refrigerant Pump Motor Starter (Mounted In Power Panel)
3M	3 Phase Purge Pump Motor Starter (Mounted In Power Panel)
1R	Steam /Hot Water Shutoff Solenoid Valve Control Relay
2R	First Stage Generator High Temperature Cut-Out Relay
3R	Relay
2SOL	Stabilizer Refrigerant Solenoid
3SOL	Refrigerant Level Solenoid
4SOL	Steam/Hot Water Shutoff Solenoid
6SOL	Steam Condensate Drain Valve Solenoid (Steam Only)
7SOL	Purge Tank Solenoid
8SOL	Purge Pump Solenoid
ISS	DPDT 3 Position Rocker Switch
IT	Class 2 Power Supply Transformer
CHFLS	Chiller Water Flow Switch Cut-Out (By - YORK / Wiring By Others)
FU	Fuse
HT	Steam or Hot Water Supply Temperature
HT1	High Temperature Cut-Out Switch
HP1	Generator High Temperature Cut-Out Switch
HP2	Steam Supply Pressure Cut-Out Transducer
LRT	Low Refrigerant Temperature Cut-Out Switch
LWT	Low Water Temperature Cut-Out (Provided By RT1)
MOV	Metal Oxide Varistor
OL	Motor Overload
PT1, PT3-PT4	Pressure Transducer
R1-RT12	Resistance Temperature Sensing Element
SUPR	Transient Suppressor
TB1, TB3, TB6	Terminal Block - Factory Wiring - 
TB2, TB4, TB5	Terminal Block - Field Connection - 
TB7	Terminal Block - Field Connection Steam Hot Water Valve Actuator - 
	Terminal Block Located in Power Panel
--- --- --- ---	Field Wiring
—————	Factory Wiring
- - - - -	Circuit Board or Enclosure Boundary
—————>	Jack (J1, J2,...)
>—————	Plug (P1, P2,...)
○	Wire Entrance Hole in Control Panel
--- - - - ---	Option (When Supplied) By YORK
--- . . . ---	Mechanical Linkage
	Shielded Cable
	Metal Oxide Varistor

NOTES

1. This wiring diagram describes the standard electronic control scheme. Refer to the Power Panel Wiring Diagram (located in the Power Panel Enclosure) for additional information for details of standard modifications. Refer to product form 155.21-W2 for Field Control Modifications.
2. Field Wiring to be in accordance with the National Electrical Code as well as all other applicable codes and specifications. Refer to product form 155.21-W3 for Field Connections.
3. Numbers along the left side of the diagram are line identification numbers. The numbers along the right side indicate the line number location of the relay contacts. An underlined contact location signifies a normally closed contact.
4. Main Control Panel Class 1 field wiring terminal connection points are indicated by numbers within a rectangle, i.e. 15. Main control panel factory wiring terminal connection points are indicated by numbers within a triangle, i.e. 2. Terminals in burner control panel are indicated by number within a hexagon, i.e. 4. Component terminal markings are indicated by numbers within a circle, i.e. C1. Numbers adjacent to circuit lines are the circuit identification numbers.
5. To cycle unit ON and OFF automatically with contacts other than those shown, install a cycling device between terminals 1 & 13 (line 24)(see note 7) if a cycling device is installed, jumper must be removed between terminals 1 & 13.
6. To stop unit and not permit it to start again, install a stop device between terminals 1 & 8 (line 20) (see note 7). A remote start-stop switch may be connected to terminals 1, 7, & 8 (lines 19 & 20)(see note 7). A remote start-stop switches (lines 19 & 20) are operative in only the "Remote" operating mode.
7. Device contact rating to be 5 milliamperes at 115 volts A.C.
8. Contact Rating is 5 Amps resistive at 120 Volts A.C. or 240 Volts A.C.
9. Maximum allowable current draw is 1 Amp holding, 10 Amps inrush for 115 VAC Field supplied Steam Hot Water shutoff valve (line 27).
10. The factory supplied jumper between terminals 4 & 53 (line 12A) must be removed when an auxiliary safety device is used.
11. Contact rating is 5 Amps resistive +/- 250 volts A.C. & 30 volts D.C. 2 Amp inductive 1.4 PFI @ 250 VAC & 30 Volts DC.
12. Each 115 VAC field-connected inductive load: i.e. relay coil, motor starter coil, etc. shall have a transient suppressor wired in parallel with it's coil physically located at the coil spare transient suppressors and control circuit fuse are supplied in a bag attached to the fuse holder.
13. Flow switch position is with chilled and condenser water circulating.
14. High Pressure Switch position is with the unit in a vacuum.
15. LRT position is when refrigerant temperature is above tripping point (40°F, 4.4°C).
18. Condenser and chilled water flow switches connected to I/O boards are optional by default, IFM flow switches are used (see microboard J14 connector for wiring).

YIA OPTIVIEW CONTROL CENTER ELEMENTARY DIAGRAM (UL)

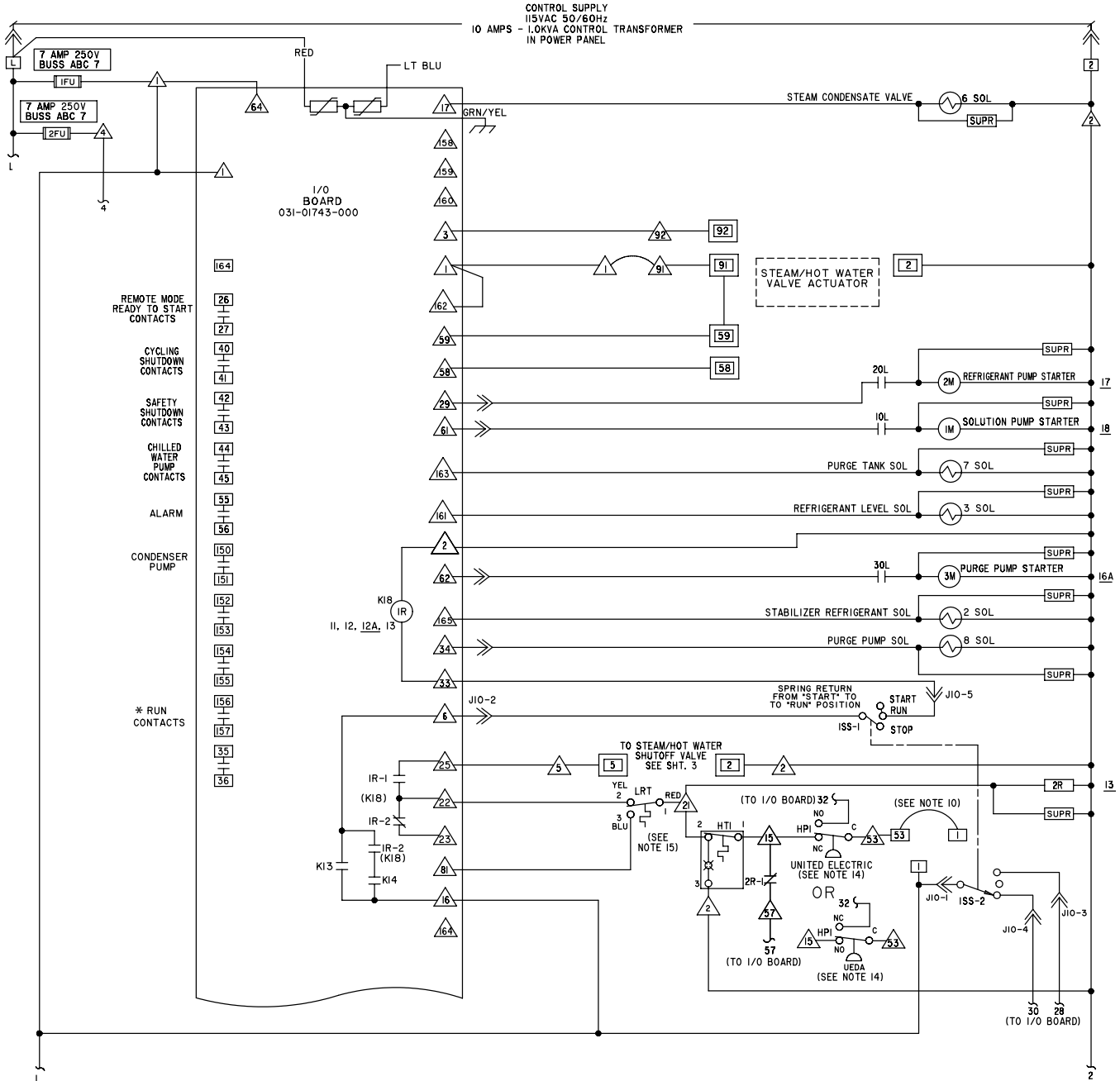

* C.OPT.15.04.200 Software version and later. Terminal 156 and 157 as shown.

LD13716

FIGURE 1 - CONTROL CENTER ELEMENTARY DIAGRAM (UL)

YIA OPTIVIEW CONTROL CENTER ELEMENTARY DIAGRAM (UL) (CONT'D)

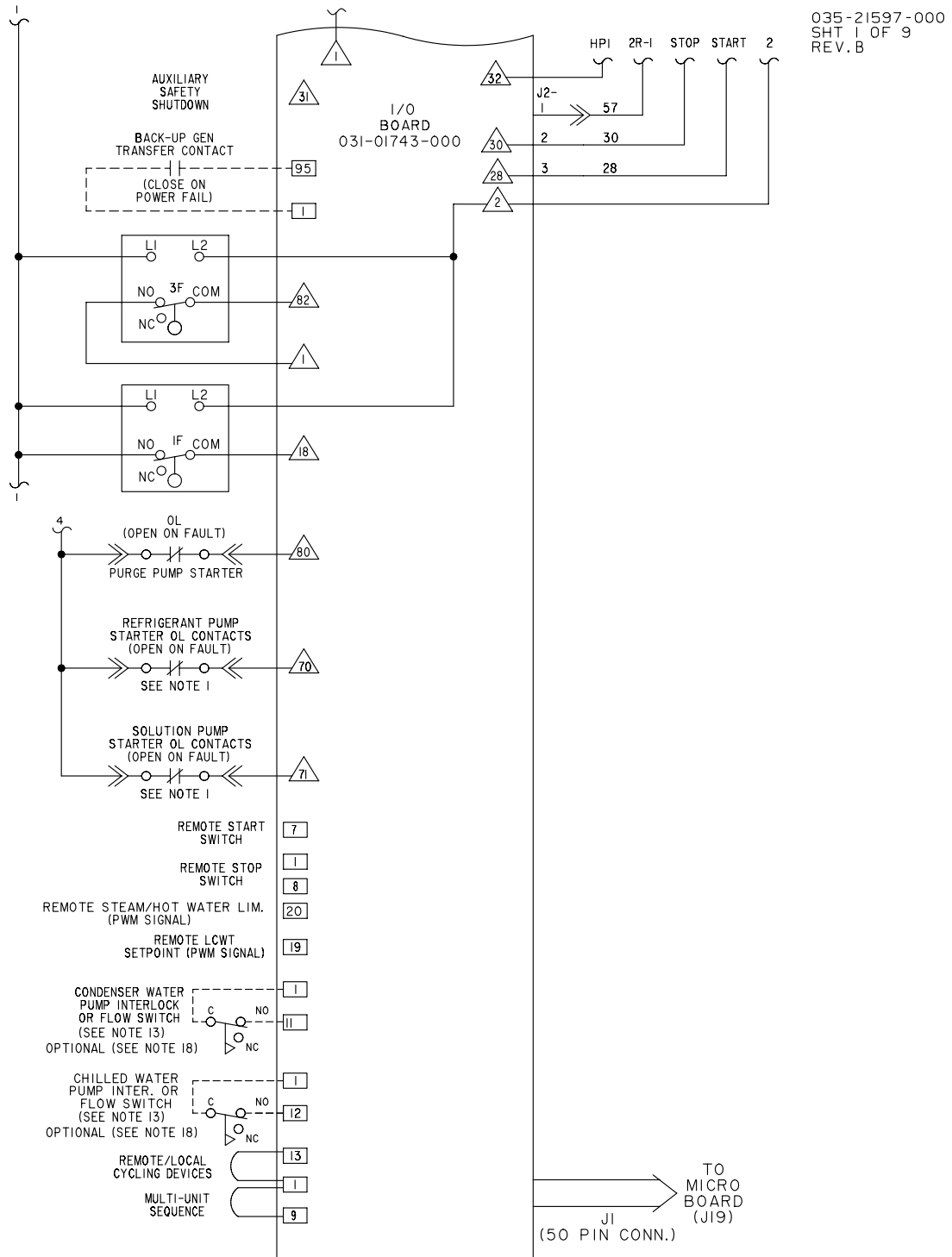
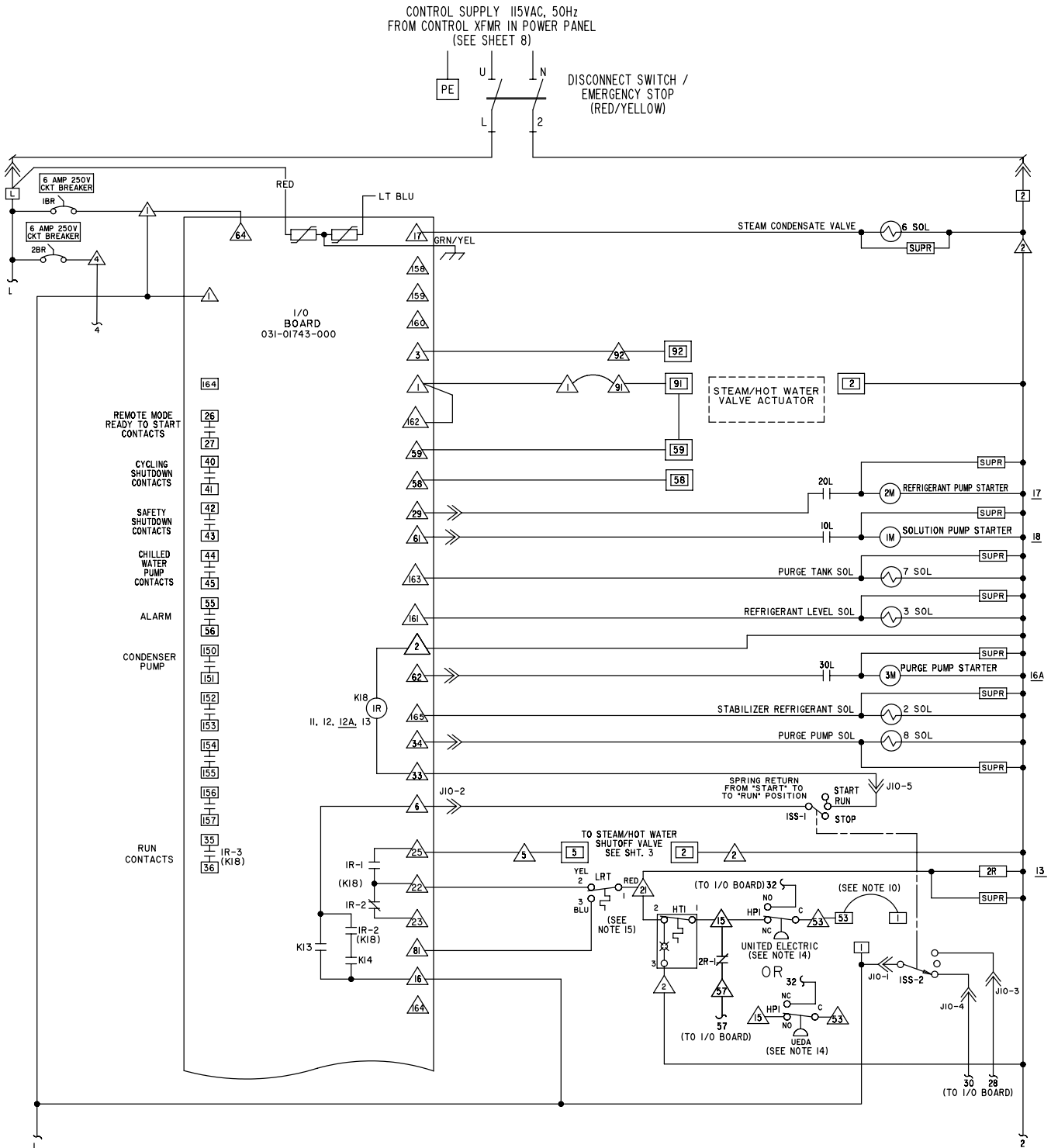

FIGURE 1 - CONTROL CENTER ELEMENTARY DIAGRAM (UL) (CONT'D)

YIA OPTIVIEW CONTROL CENTER ELEMENTARY DIAGRAM (CE)



LD13718

FIGURE 2 - CONTROL CENTER ELEMENTARY DIAGRAM (CE)

YIA OPTIVIEW CONTROL CENTER ELEMENTARY DIAGRAM (CE) (CONT'D)

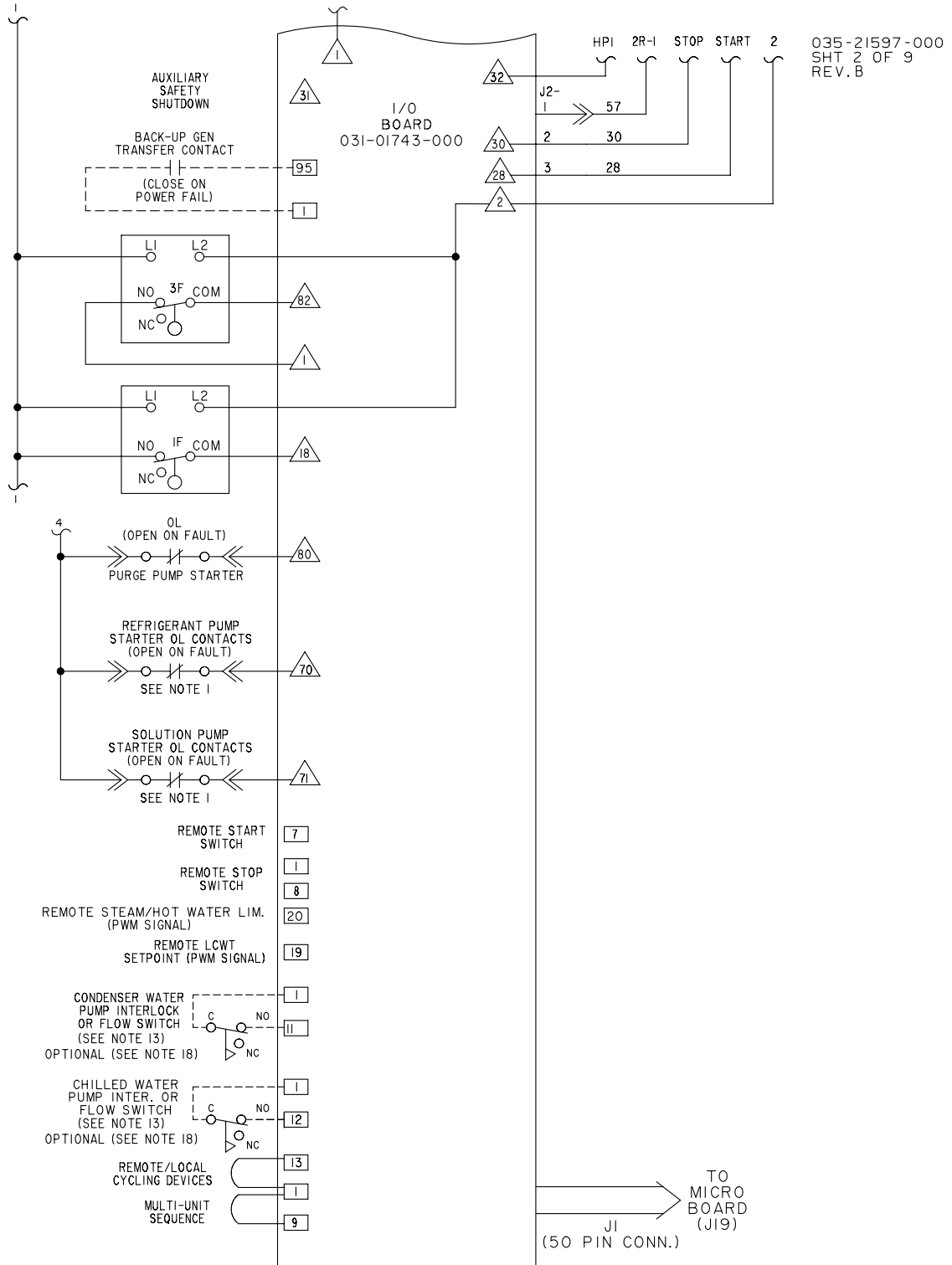
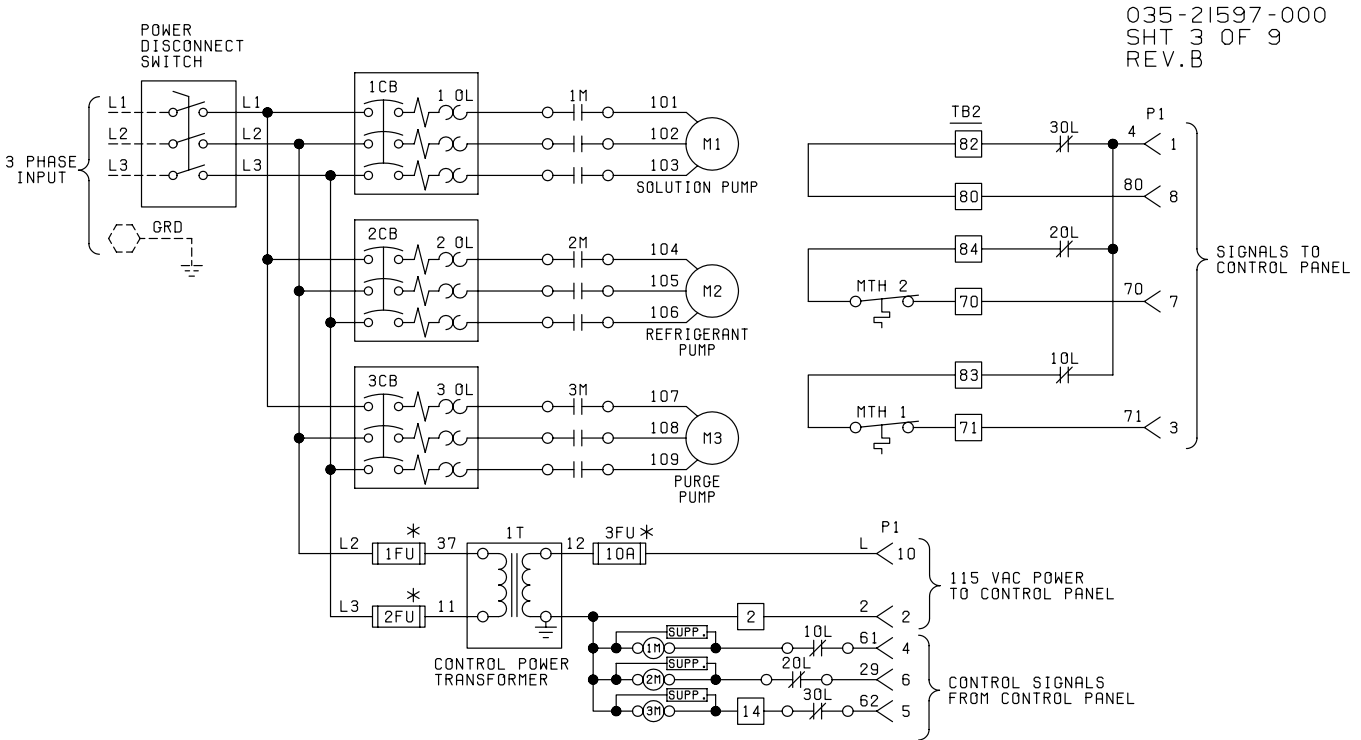

FIGURE 2 - CONTROL CENTER ELEMENTARY DIAGRAM (CE) (CONT'D)

POWER PANEL ELEMENTARY DIAGRAM



* FOR NEMA 4 AND CE APPLICATIONS
 FUSES 1FU AND 2FU ARE REPLACED
 WITH A TWO POLE CIRCUIT BREAKER.
 1CB, FUSE 3FU IS REPLACED WITH
 CIRCUIT BREAKER 2CB.

PANEL STYLE	PRIMARY VOLTS	CKT BREAKER INFO	
		1CB	2CB
NEMA 4	208V-3PH-60HZ.	10A	10A
	230V-3PH-60HZ.	8A	10A
	460V-3PH-60HZ.	5A	10A
	575V-3PH-60HZ.	5A	10A
CE	380-415V-3PH-50HZ.	6A	10A

PRIMARY VOLTS	FUSE INFO.	
	1FU	2FU
208V-3PH-60HZ.	12A	12A
230V-3PH-60HZ.	10A	10A
460V-3PH-60HZ.	5A	5A
575V-3PH-60HZ.	5A	5A

LD13721

FIGURE 3 - POWER PANEL ELEMENTARY DIAGRAM

CONTROL PANEL ELEMENTARY DIAGRAM

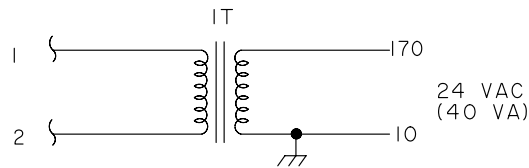
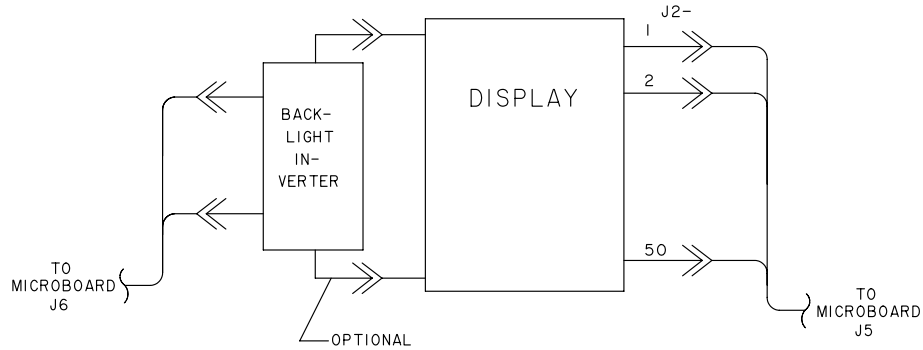
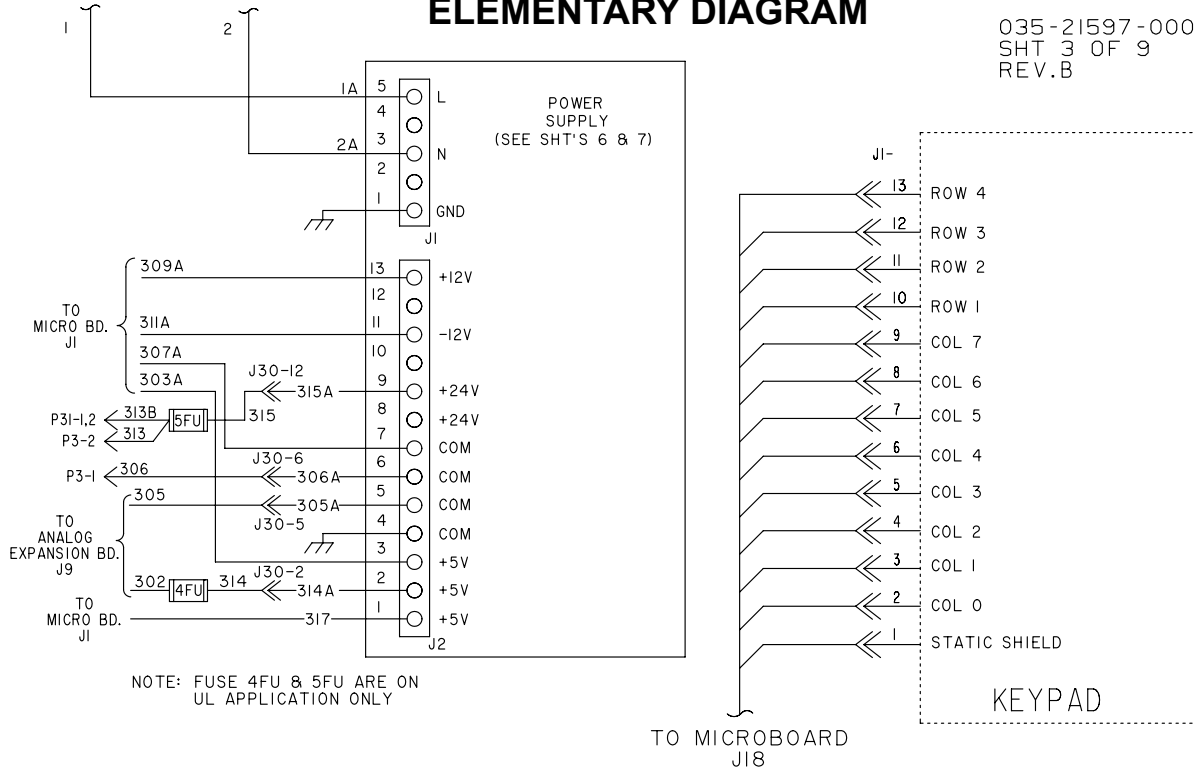

FIGURE 4 - CONTROL PANEL ELEMENTARY DIAGRAM

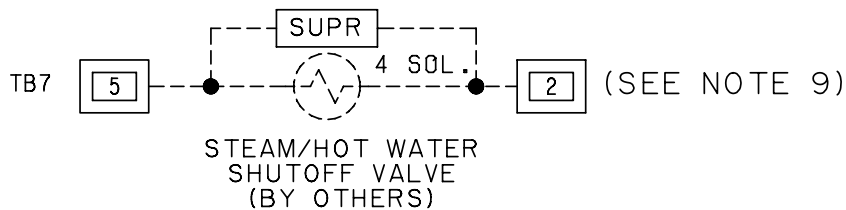
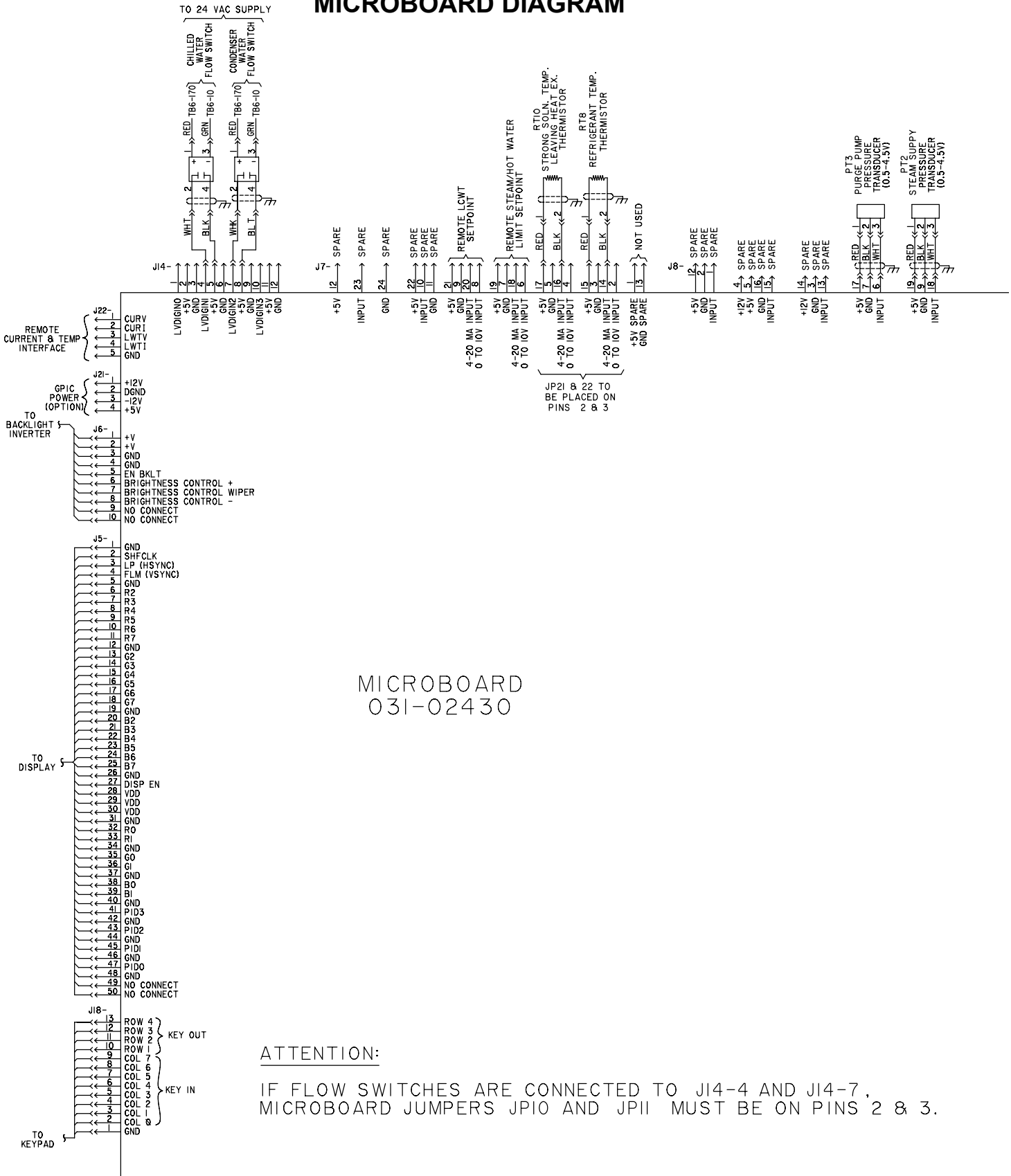

FIGURE 5 - JUNCTION BOX (JB3) DIAGRAM

MICROBOARD DIAGRAM



MICROBOARD
 031-02430

ATTENTION:

IF FLOW SWITCHES ARE CONNECTED TO J14-4 AND J14-7, MICROBOARD JUMPERS JP10 AND JP11 MUST BE ON PINS 2 & 3.

FIGURE 6 - MICROBOARD

LD13724

MICROBOARD DIAGRAM (CONT'D)

035-21597-000
 SHT 4 OF 9
 REV. B

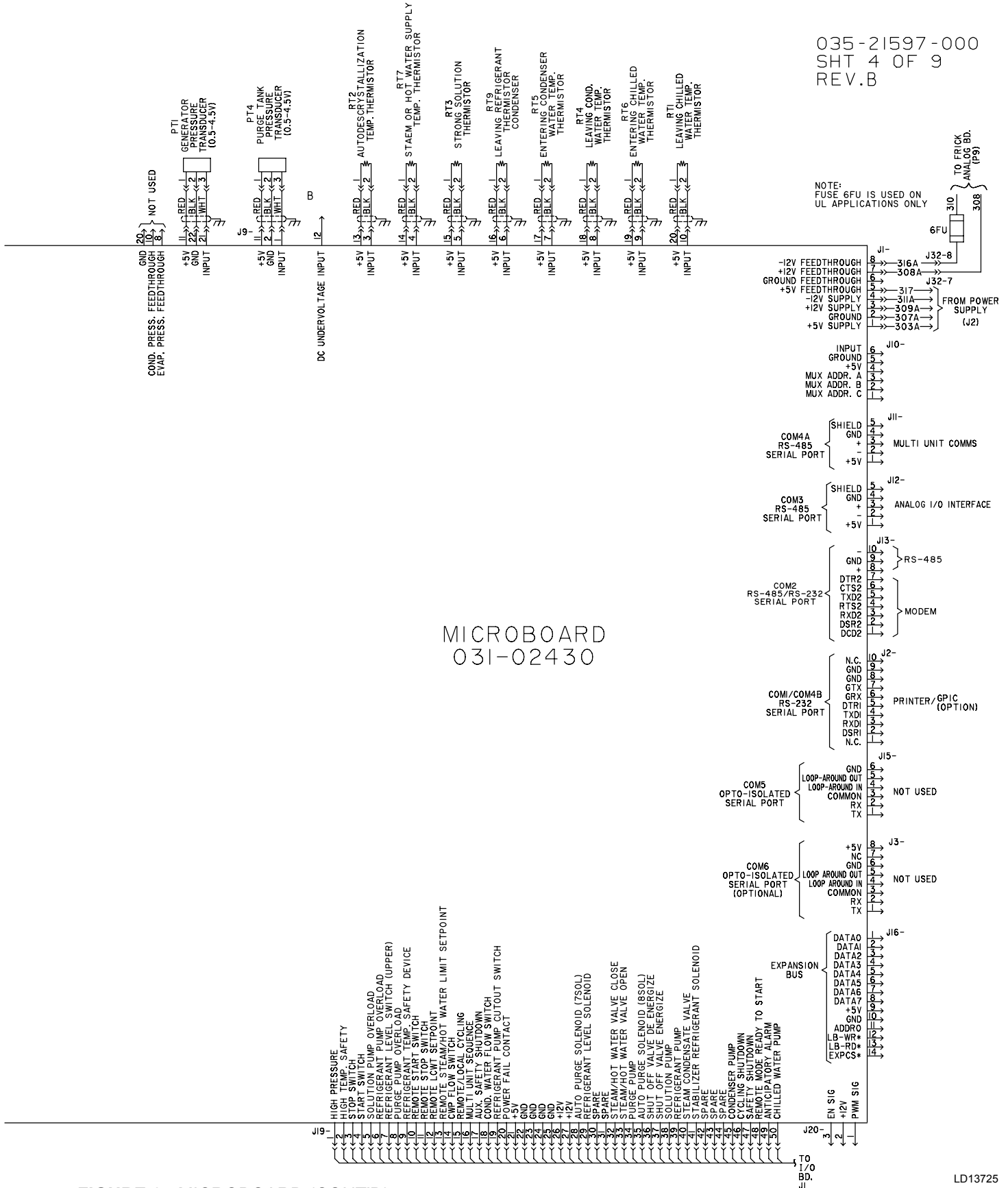
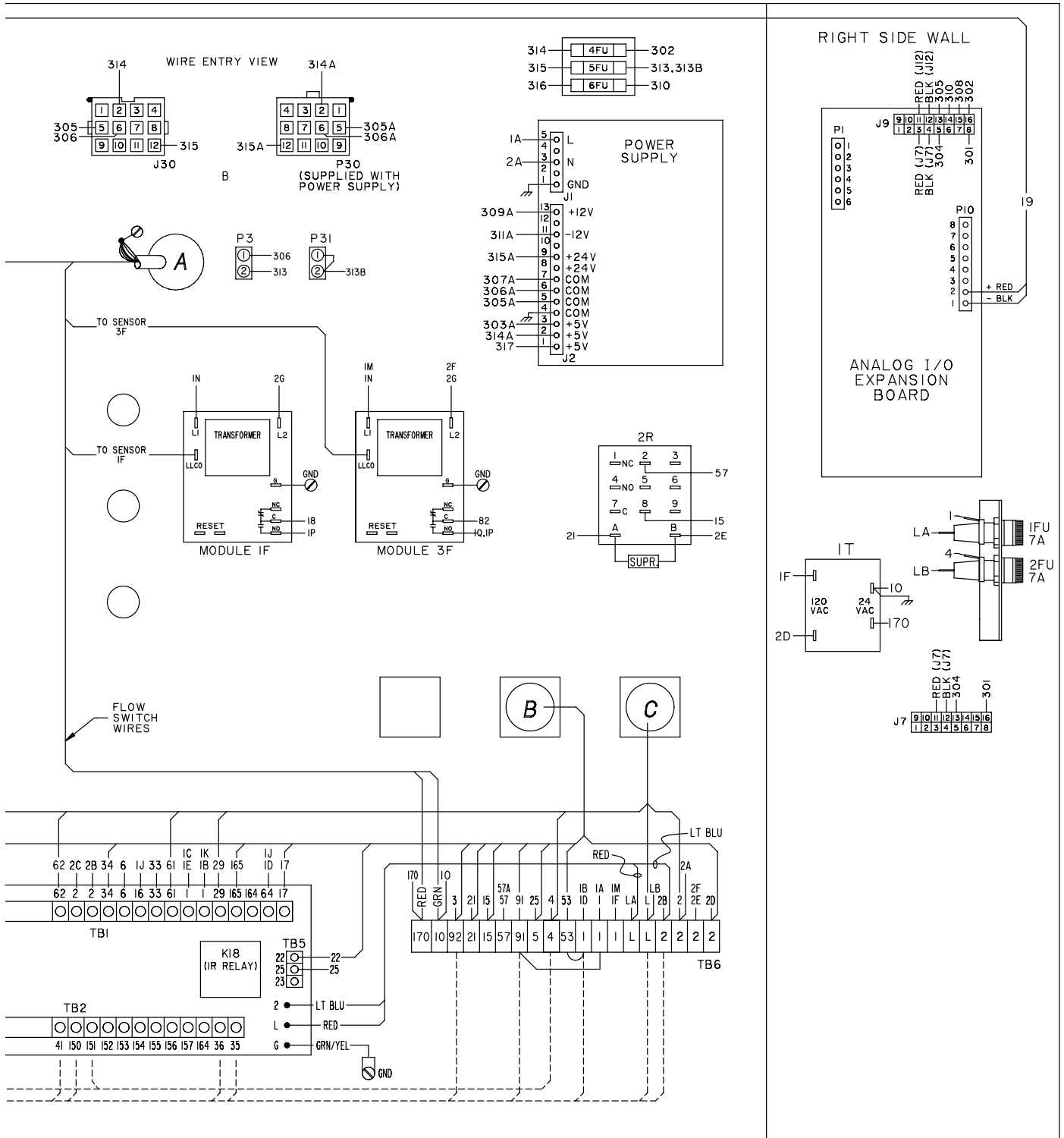

FIGURE 6 - MICROBOARD (CONT'D)

CONTROL PANEL DIAGRAM (CONT'D)



(UL APPLICATION ONLY)

035-21597-000
 SHT 6 OF 9
 REV.B

FIGURE 7 - CONTROL PANEL (UL) (CONT'D)

CONTROL PANEL DIAGRAM

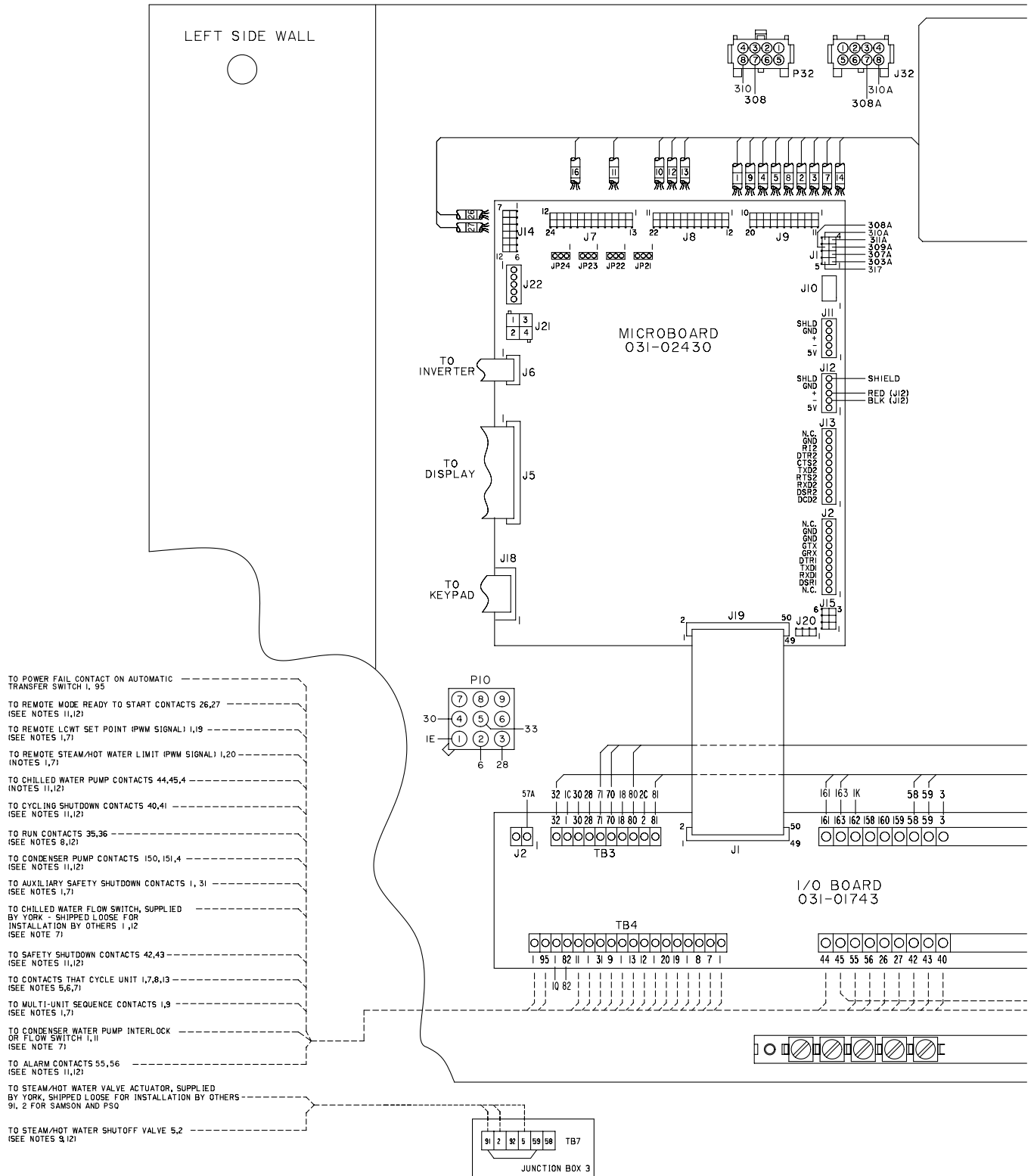
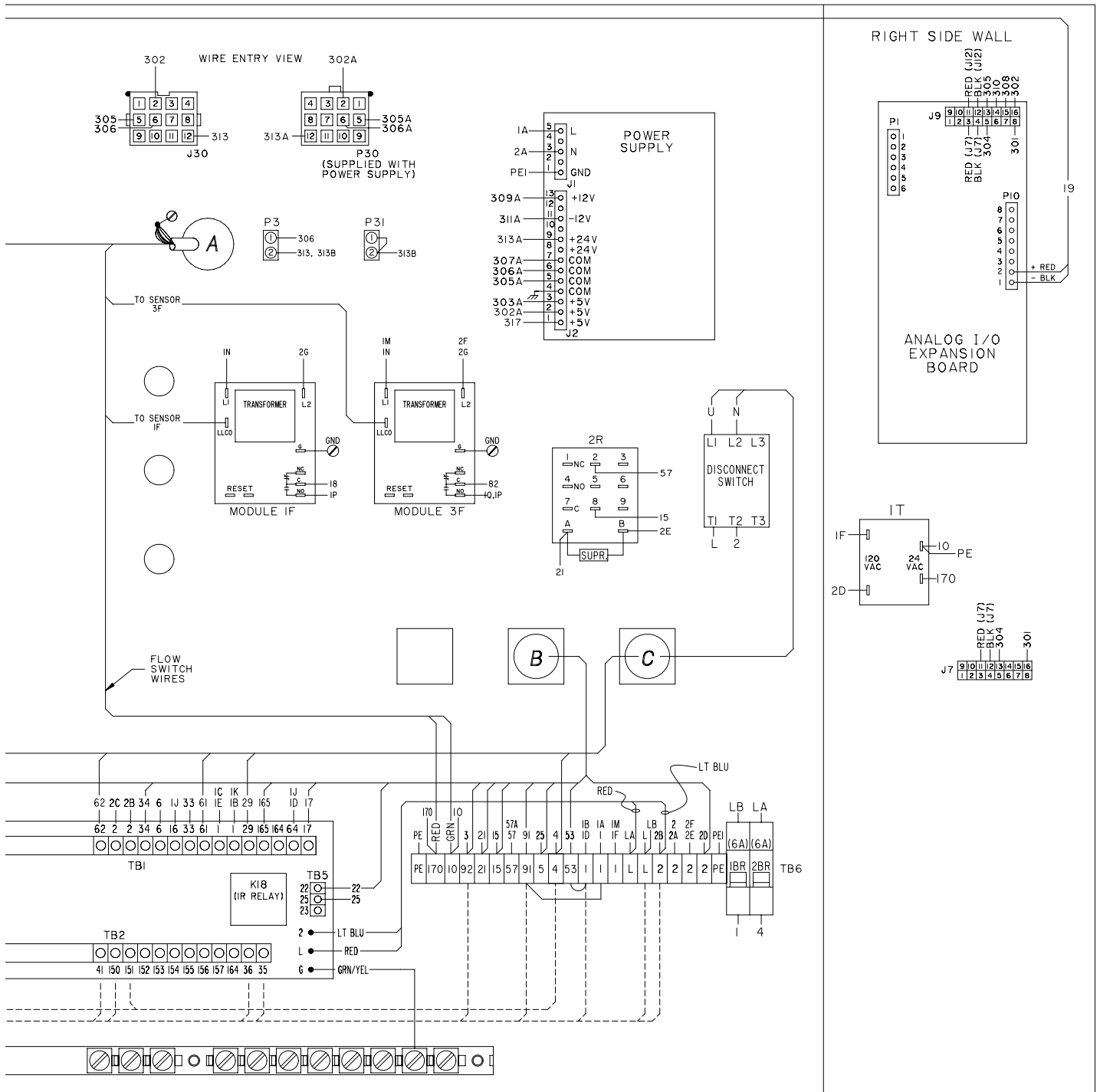

FIGURE 8 - CONTROL PANEL (CE)

LD13797

CONTROL PANEL DIAGRAM (CONT'D)



(CE APPLICATION ONLY)

035-21597-000
 SHT 7 OF 9
 REV. B

FIGURE 8 - CONTROL PANEL (CE) (CONT'D)

CONNECTION DIAGRAM

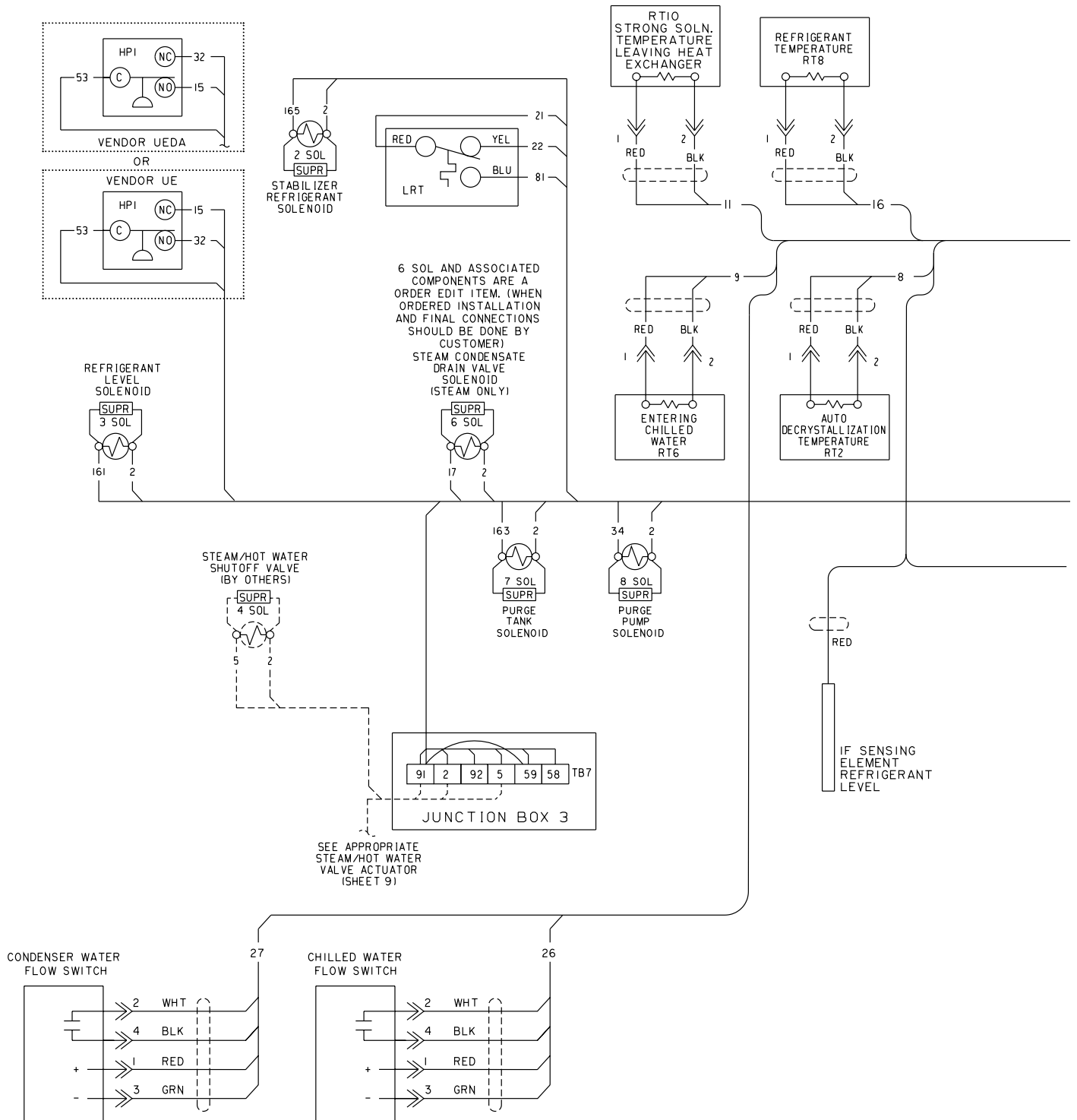

FIGURE 9 - CONNECTION DIAGRAM

LD13799

CONNECTION DIAGRAM (CONT'D)

035-21597-000
 SHT 8 OF 9
 REV. B

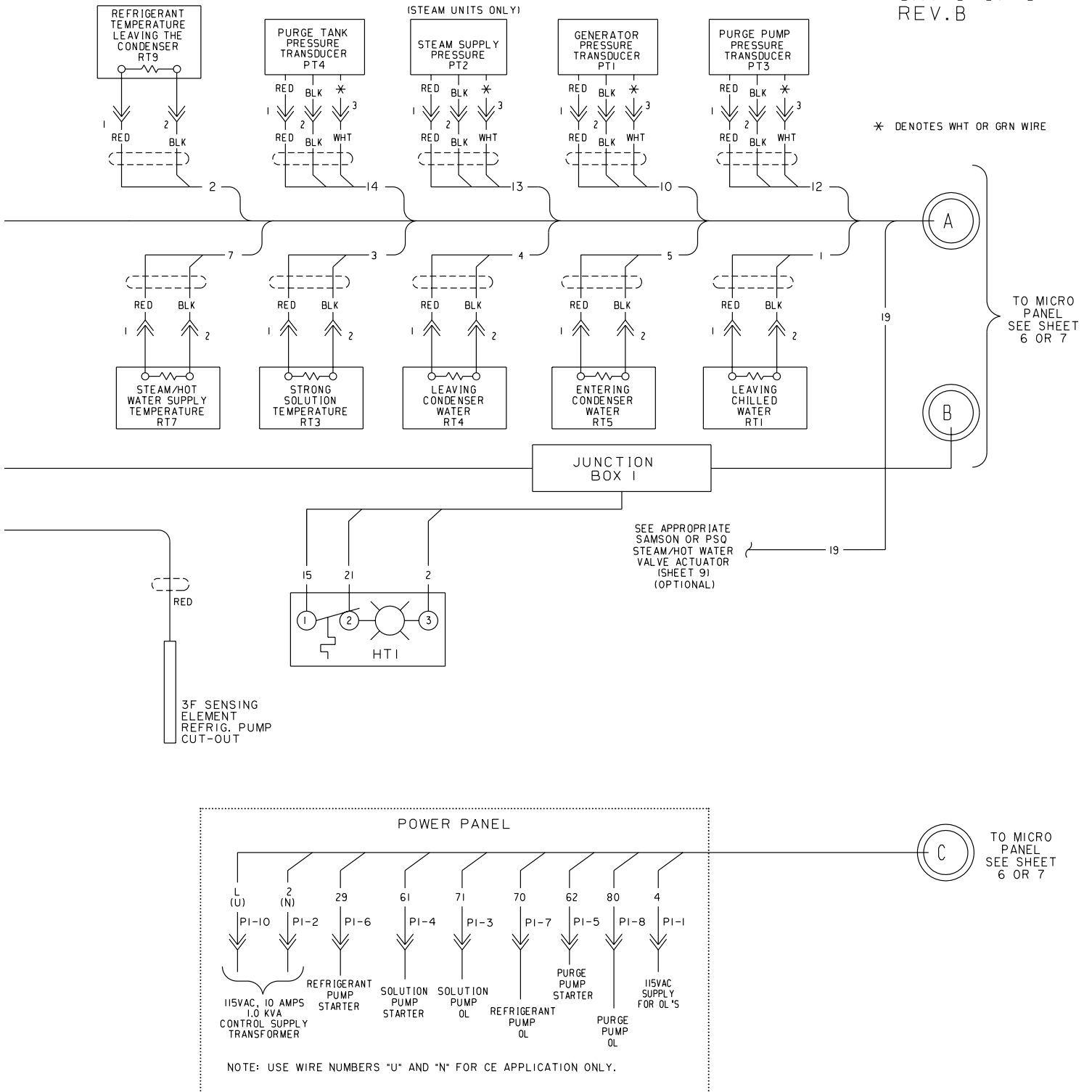

FIGURE 9 - CONNECTION DIAGRAM (CONT'D)

DISPLAY DIAGRAM

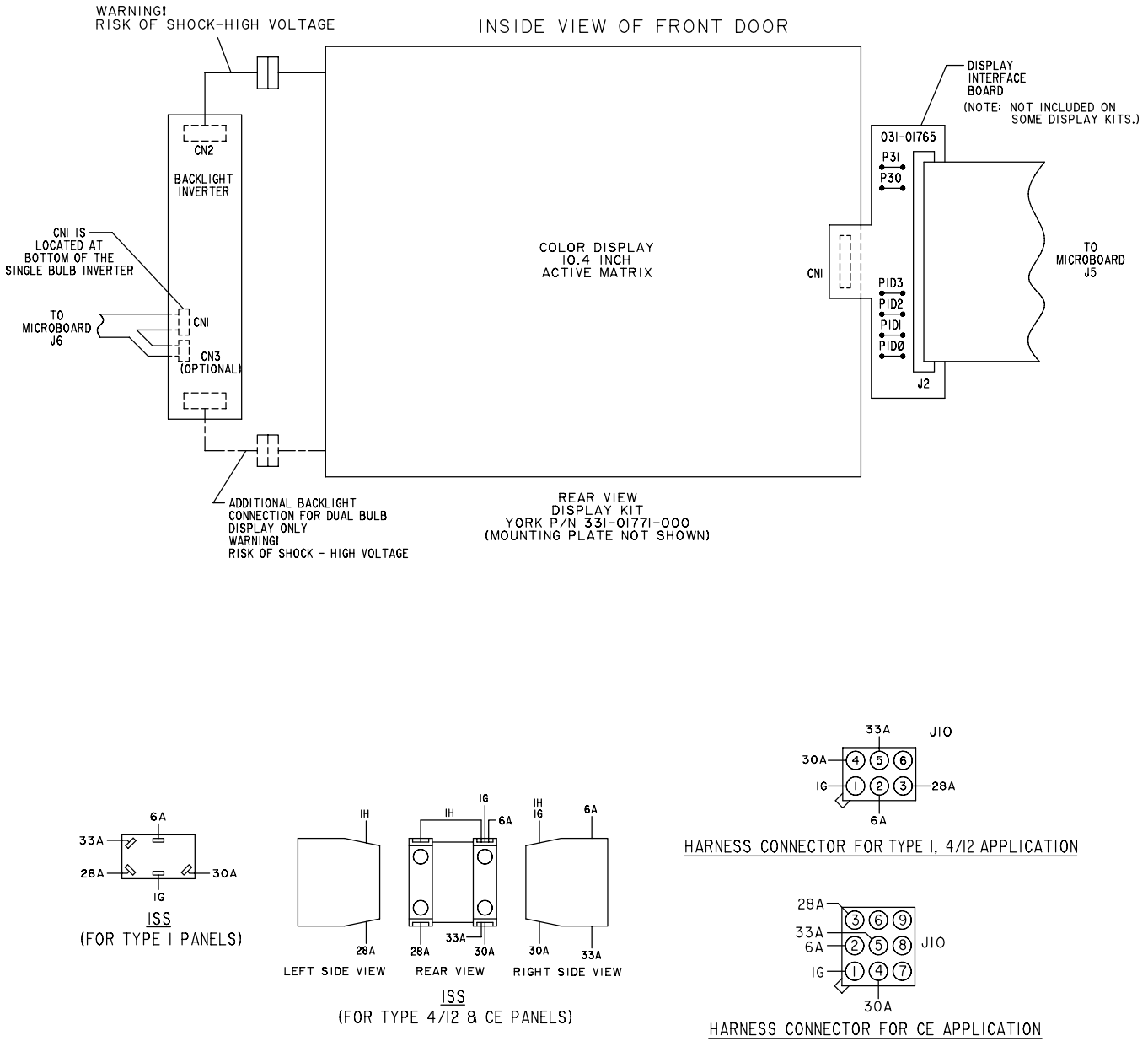

FIGURE 10 - DISPLAY DIAGRAM

LD13726

YIA OPTIVIEW CONTROL CENTER PRESSURE - TEMPERATURE CHART

PRESSURE-TEMPERATURE CHART FOR OPTIVIEW PANELS									
APPLICATIONS	TYPE UNIT		DEVICE	DIG/ ANA	UNITS	OPERATING POINT			
	STEAM	HOT WATER				ON RISE		ON FALL	
						INCREASING		DECREASING	
HIGH PRESSURE, GEN SHELL	X	X	HPI	DIG	mm Hg Abs	SHUTDOWN 710.0		RECOVERY 40.0	
			PTI	ANA		WARNING 517.0	SHUTDOWN 672.3	WARNING RECOVERY 310.0	SHUTDOWN RECOVERY <672.7
HIGH TEMPERATURE, GEN SHELL	X	X	HTI	DIG	Deg F/Deg C	SHUTDOWN 337/169.4		RECOVERY 333/167.2	
			RT3	ANA	Deg F/Deg C	SHUTDOWN 330/165.6		RECOVERY 329/165.0	
HIGH PRESSURE, STEAM SUPPLY	X		PT2	ANA	PSIA/Kpa	WARNING 32.0/220.6	SHUTDOWN 35.0/241.3	WARNING RECOVERY <31.0/213.7	SHUTDOWN RECOVERY 31.0/213.7
HIGH TEMPERATURE, STEAM SUPPLY	X		RT7	ANA	Deg F/Deg C	WARNING 337/169.4	SHUTDOWN 340/171.1	WARNING RECOVERY 336/168.9	SHUTDOWN RECOVERY 339/170.1
HIGH TEMPERATURE, HOT WATER		X	RT7	ANA	Deg F/Deg C	WARNING 266/130	SHUTDOWN 270/132.2	WARNING RECOVERY 265.5/129.7	SHUTDOWN RECOVERY 269/131.7
LOW REFRIGERANT TEMPERATURE	X	X	LRT	DIG	Deg F/Deg C	RECOVERY 37.0/2.7		SHUTDOWN 33.0/0.6	
			RT8	ANA	Deg F/Deg C	RECOVERY 37.0/2.7		SHUTDOWN 33.0/0.6	

LD13720

FIGURE 11 - PRESSURE - TEMPERATURE CHART

TIMING DIAGRAM

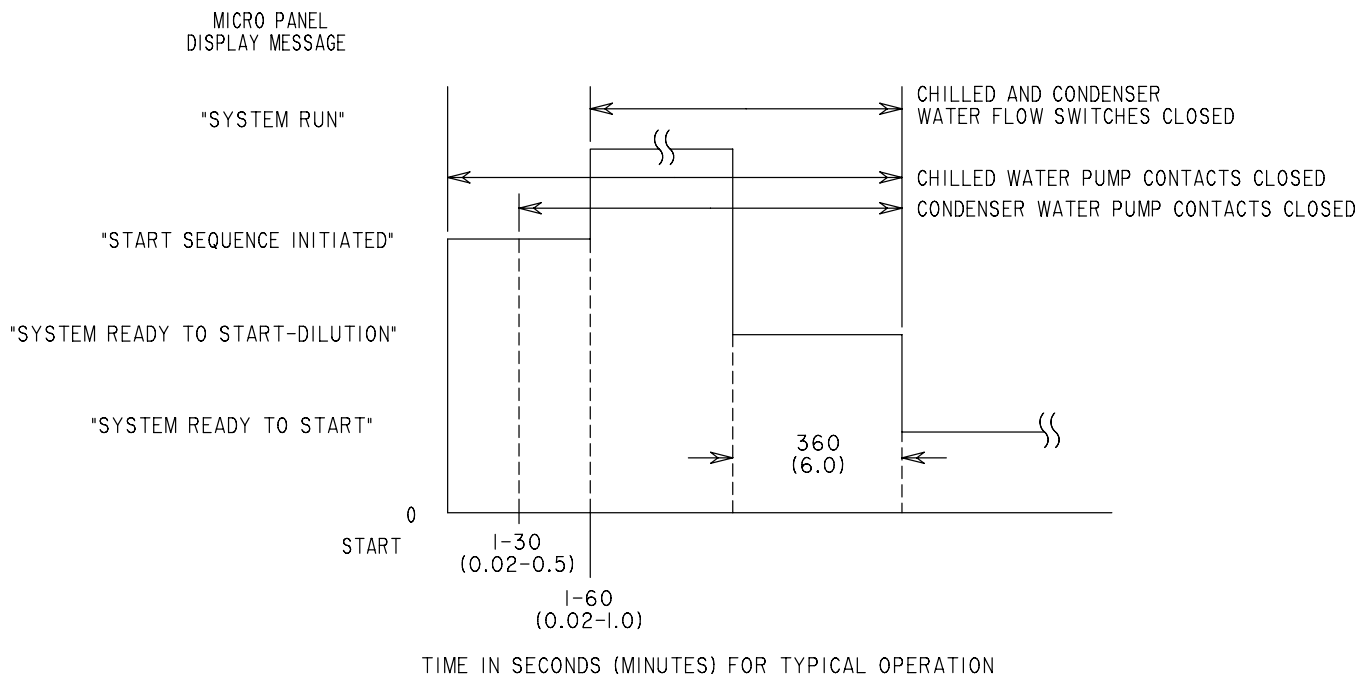

LD13720

FIGURE 12 - TIMING DIAGRAM

WATER / STEAM VALVE ACTUATORS

035-21597-000
 SHT 9 OF 9
 REV. B

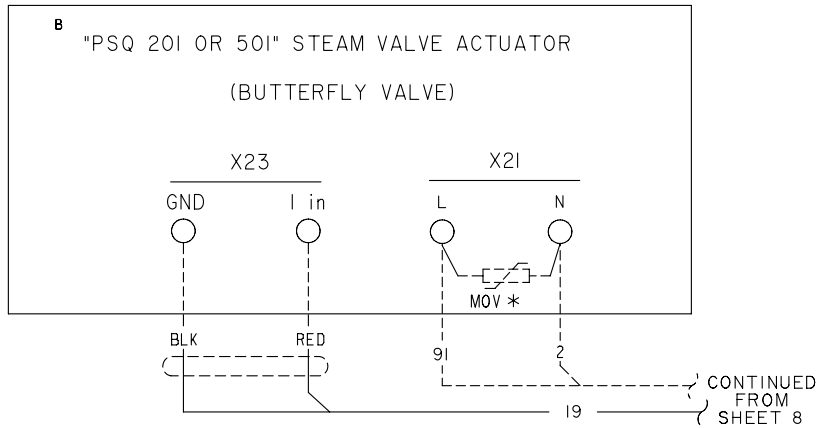

* MOV'S ARE PROVIDED IN BAG SUPPLIED INSIDE CONTROL PANEL. INSTALL AS SHOWN.

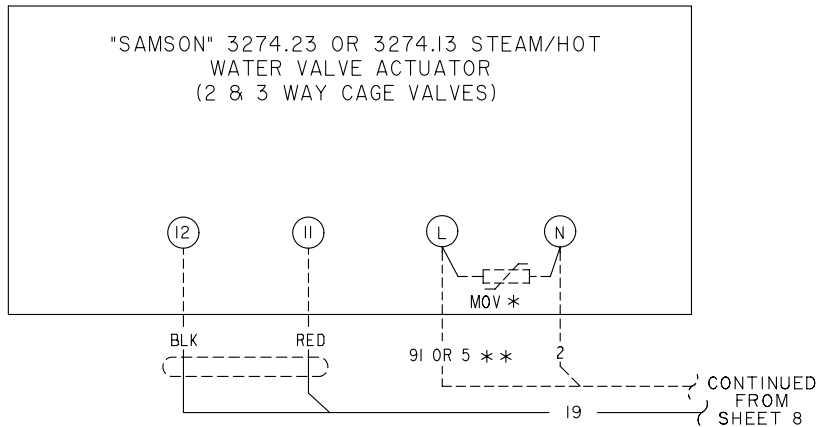

** WIRE CONNECTED TO TERMINAL "L" IS "91" FOR 3274.13 OR "5" FOR 3274.23.

FIGURE 13 - STEAM / WATER VALVE ACTUATORS

LD13727

NOTES



P.O. Box 1592, York, Pennsylvania USA 17405-1592
Copyright © by Johnson Controls 2015
Form 155.21-W1 (615)
Issue Date: June 26, 2015
Supersedes: 155.21-W1 (110)

800-861-1001
www.johnsoncontrols.com

Subject to change without notice. Printed in USA
ALL RIGHTS RESERVED