



## COMPOUND YK CENTRIFUGAL LIQUID CHILLER

RENEWAL PARTS

Supersedes: 160.82-RP1 (513)

Form 160.82-RP1 (816)

### MODEL CYK CENTRIFUGAL CHILLER / HEAT PUMP SYSTEM WITH QUANTUM™ LX CONTROLS



LD15345

**R-134a**

Issue Date:  
August 12, 2016



# IMPORTANT!

## READ BEFORE PROCEEDING!

### GENERAL SAFETY GUIDELINES

This equipment is a relatively complicated apparatus. During installation, operation maintenance or service, individuals may be exposed to certain components or conditions including, but not limited to: refrigerants, materials under pressure, rotating components, and both high and low voltage. Each of these items has the potential, if misused or handled improperly, to cause bodily injury or death. It is the obligation and responsibility of operating/service personnel to identify and recognize these inherent hazards, protect themselves, and proceed safely in completing their tasks. Failure to comply with any of these requirements could result in serious damage to the equipment and the property in

which it is situated, as well as severe personal injury or death to themselves and people at the site.

This document is intended for use by owner-authorized operating/service personnel. It is expected that these individuals possess independent training that will enable them to perform their assigned tasks properly and safely. It is essential that, prior to performing any task on this equipment, this individual shall have read and understood this document and any referenced materials. This individual shall also be familiar with and comply with all applicable governmental standards and regulations pertaining to the task in question.

---

### SAFETY SYMBOLS

The following symbols are used in this document to alert the reader to specific situations:



*Indicates a possible hazardous situation which will result in death or serious injury if proper care is not taken.*



*Identifies a hazard which could lead to damage to the machine, damage to other equipment and/or environmental pollution if proper care is not taken or instructions are not followed.*



*Indicates a potentially hazardous situation which will result in possible injuries or damage to equipment if proper care is not taken.*

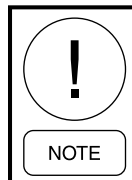

*Highlights additional information useful to the technician in completing the work being performed properly.*



*External wiring, unless specified as an optional connection in the manufacturer's product line, is not to be connected inside the control cabinet. Devices such as relays, switches, transducers and controls and any external wiring must not be installed inside the micro panel. All wiring must be in accordance with Johnson Controls' published specifications and must be performed only by a qualified electrician. Johnson Controls will NOT be responsible for damage/problems resulting from improper connections to the controls or application of improper control signals. Failure to follow this warning will void the manufacturer's warranty and cause serious damage to property or personal injury.*

## CHANGEABILITY OF THIS DOCUMENT

In complying with Johnson Controls' policy for continuous product improvement, the information contained in this document is subject to change without notice. Johnson Controls makes no commitment to update or provide current information automatically to the manual owner. Updated manuals, if applicable, can be obtained by contacting the nearest Johnson Controls Service office or accessing the Johnson Controls QuickLIT website at <http://cgproducts.johnsoncontrols.com>.

Operating/service personnel maintain responsibility for the applicability of these documents to the equipment. If there is any question regarding the applicability of

these documents, the technician should verify whether the equipment has been modified and if current literature is available from the owner of the equipment prior to performing any work on the chiller.

### CHANGE BARS

Revisions made to this document are indicated with a line along the left or right hand column in the area the revision was made. These revisions are to technical information and any other changes in spelling, grammar or formatting are not included.

---

## ASSOCIATED LITERATURE

MANUAL DESCRIPTION	FORM NUMBER
Operation and Maintenance	160.82-OM1
Startup Checklist	160.82-CL1
Wiring Diagrams	160.82-PW1

THIS PAGE INTENTIONALLY LEFT BLANK.

## LIST OF FIGURES





<b>FIGURE 1</b> - Quantum™ LX Basic Panel Layout #1 .....	9
<b>FIGURE 2</b> - Quantum™ LX Basic Panel Layout #2 .....	10
<b>FIGURE 3</b> - Analog Board Diagram.....	11
<b>FIGURE 4</b> - Digital Board #1 .....	12
<b>FIGURE 5</b> - Digital Board #2 .....	13
<b>FIGURE 6</b> - Time On Delay .....	14
<b>FIGURE 7</b> - Power Panel .....	16
<b>FIGURE 8</b> - System Compound CYK Chiller (Front View) .....	20
<b>FIGURE 9</b> - System Compound CYK Chiller (Side View) .....	21
<b>FIGURE 10</b> - System Compound CYK Chiller (Rear View).....	22
<b>FIGURE 11</b> - Low Stage Compressor .....	23

## LIST OF TABLES

<b>TABLE 1</b> - Quantum™ LX Control Panel Components.....	6
<b>TABLE 2</b> - VSOP Panel Part Numbers by Voltage .....	15
<b>TABLE 3</b> - VSOP Power Panel Parts .....	16
<b>TABLE 4</b> - Pressure Sensors .....	17
<b>TABLE 5</b> - ICTD Temperature Sensors .....	17
<b>TABLE 6</b> - Level Sensors.....	17
<b>TABLE 7</b> - Miscellaneous Sensors.....	18
<b>TABLE 8</b> - Actuators.....	18
<b>TABLE 9</b> - Current Transformers .....	19

## CONTROL CENTER COMPONENTS

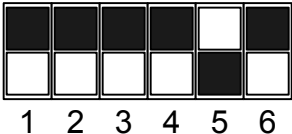
**TABLE 1 - QUANTUM™ LX CONTROL PANEL COMPONENTS**

ITEM	DESCRIPTION	YORK NUMBER	SAP / FRICK NUMBER(s)	FIGURE
1	Analog Board #1 	031-02472-011	1179722 6491160G01	2
2	Analog Board #2 	031-02472-012	1179723 649C1160G02	2
3	Analog Board #3 	031-02472-013	1179724 649C1160G03	3
4	Digital Board #1 	377-30571-001	803622 649C1144G01	2
5	Digital Board #2 	377-30571-002	924713 649C1144G02	2
6	3 AMP Circuit Breaker Weidmuller 9926251003	024-37335-000	484045 639A0206H03	2
7	5 AMP Circuit Breaker Weidmuller 9926251005	024-37336-000	484047 639A0206H05	2
8	15 AMP Circuit Breaker Weidmuller 9926251015	024-37337-000	484053 639A0206H15	2
9	2-Pole Connector (P8 Analog Board)	025-43689-000	486156 649B0903H01	2
10	6-Pole Connector (P1-P6 Dig Board) (P4A-P10B Analog Board)	025-37816-000	467049 333Q0001258	2
11	8 Pole Connector (P11A-P11B Analog Board)	025-37816-001	467040 333Q0001234	2
12	9-Pole Connector (P2 Analog Board)	025-43690-000	486157 649B0903H02	2
13	CORCOM RF Line Filter #5VR1	025-43691-000	467096 333Q0001418	3

**TABLE 1 - QUANTUM™ LX CONTROL PANEL COMPONENTS (CONT'D)**

ITEM	DESCRIPTION	YORK NUMBER	SAP / FRICK NUMBER(s)	FIGURE
14	Switch, Selector, 2 Position AB# 800FP-SM22	024-37344-000	483963 639A0185H10	1
15	Contact Block, N.O., For Selector SW. AB# 800F-XIO	024-37346-000	483969 639A0185H36	1
16	Latch, 3 Across, For Selector SW. AB# 800F-ALP	024-37345-000	483966 639A0185H30	1
17	Relay Socket 2PDT IDEC #SH2B-05C	024-37338-001	466846 333Q0000195	2
18	Relay Socket 3-Pole DT IDEC #SH3B-05C	024-37339-001	466849 333Q0000207	2
19	Clip, Relay IDEC #SFA-101 (Use With IDEC #SH2B-05C Two Per Relay)	024-37340-000	466847 333Q0000196	*
20	Relay 2-Pole DPDT 10AMP IDEC #RH2B-ULC-120AC	024-37338-000	466845 333Q0000194	2
21	Relay 3-Pole 3PDT 10AMP IDEC # RH3B-ULAC1120V	024-37339-000	466848 333Q0000206	2
22	Suppressor, Surge	031-00808-000	455040 111Q0280958	*
23	Module, Output 24 VDC TYCO ODCM-5	025-43688-001	467015 333Q0001172	*
24	Module, Output 24-280 VAC TYCO OACM-5	025-37818-000	455056 111Q0281061	2,4,5
25	Module, Input 24 VDC TYCO IDCM-5	025-43688-000	467014 333Q0001171	5
26	Module, Input 120 VAC TYCO AICM-5	025-37817-000	466842 333Q0000116	2,4,5
27	Micro Fuse, 5 AMP, 250V	024-37347-000	467073 333Q0001326	4
29	Harness, Display, QTM 5, LVDS, Sharp Display	025-43712-001	670741 639B0117H01	1
30	Display, Sharp, #LQ104V1DG81	025-43713-001	830635 639C0144H01	1
31	Fan, Circulation, Field Install 115V	025-43693-000	485995 649A0906G11	2
33	Heater, Panel, 400W, 120VAC	024-37342-000 (Optional)	484627 640M0007G18	*
34	Power Supply Bracket	025-46188-000	664673 639B0119H01	1
34a	Power Supply 5v	025-46188-001	642307 639B0115H01	1
34b	Power Supply 12v	025-46188-002	642308 639B0115H02	1
34c	Power Supply 24v	025-46188-003	642309 639B0115H03	1
35	Supply, Power DC, Din Mount, 10Watt, Carlo Gavazzi # SPM1-241	025-43694-000	506142 639A0262H03	2

NOTE: Items with an \* are NOT represented.

**TABLE 1 - QUANTUM™ LX CONTROL PANEL COMPONENTS (CONT'D)**

ITEM	DESCRIPTION	YORK NUMBER	SAP / FRICK NUMBER(s)	FIGURE
37	Compact Flash Drive, 1GB, CYK Program	025-44606-004	959121 639A0335H03	1
38	Drive, USB, Setpoint Saver	025-43697-000	485995 649A1063G99	*
39	Gateway, Data Station Plus, Redlion	025-42239-000	816658	2
39a	Cable, Serial RS-232 To RJ-11	025-43698-000	552142 639B0108H01	1
40	Relay, Time On Delay (Refer to Configure the Time On Delay information on page 14)	025-44607-000	836397	2
41	Board, Stall Detector	031-02418-001	360270	2
42	Harness, Stall Detector	377-18332-401	802000	2
43	Harness, Stall Detector	377-18332-402	802001	2
44	Switch, Emergency Stop	024-37343-000	483965 639A0185H22	1
45	Terminal Block, WDU 2.5.200	024-37348-000	467018 333Q0001183	2
46	Terminal Block, WDU 4.240	024-37349-000	467019 333Q0001184	2
47	Terminal Block Ground, WPE 4	024-37350-000	467020 333Q0001185	2
51	Keypad / Touchscreen, York Logo #5099	025-43702-000	546857 639D0182H11	1
52	Microprocessor Board, QTM 5, Avantech	025-44606-001	641274 639C0141H01	1
53	Kit, QTM5, Controller Assembly Inside	025-44606-000	865280 639D0230G01	1
53A	Kit, QTM5, Controller, Assembly Outdoor	025-44606-010	865281 639D0223G11	
54	Adapter Board, COMM Expansion, QTM 5 Controller	025-44606-002	677556 639B0116H01	1
56	Harness, Wire CYK DC Power Controller	025-44608-000	677558 639D0192H01	1
57	Harness, Wire CYK DC Power I/O	025-43708-000	551183 639D0179H01	2
59	Memory, RAM Board	025-43710-000	553066	1
60	Socket, Relay, IDEC #SY4S-05C	024-37351-001	484000 639A0194H04	2
61	Relay, IDEC#RY42S-ULCAC110-120V	024-37351-000	484001 639A0195H43	2
62	Fuse, 2 Amp Cartridge	025-34592-000	48817	2
63	Battery CMOS <ul style="list-style-type: none"> <li>• Replace this battery once every other year</li> </ul> Replace CMOS battery with QuantumLX power ON <ul style="list-style-type: none"> <li>• Wear proper Personal Protective Equipment</li> <li>• Failure to replace this battery with power ON will result in lost CMOS settings and a new board will need to be ordered.</li> </ul>	025-44606-003	CR2032	1
65	Converter, Serial, RS-232 to RS-485 (optional)	025-44395-000	639B0086H01 484330	2

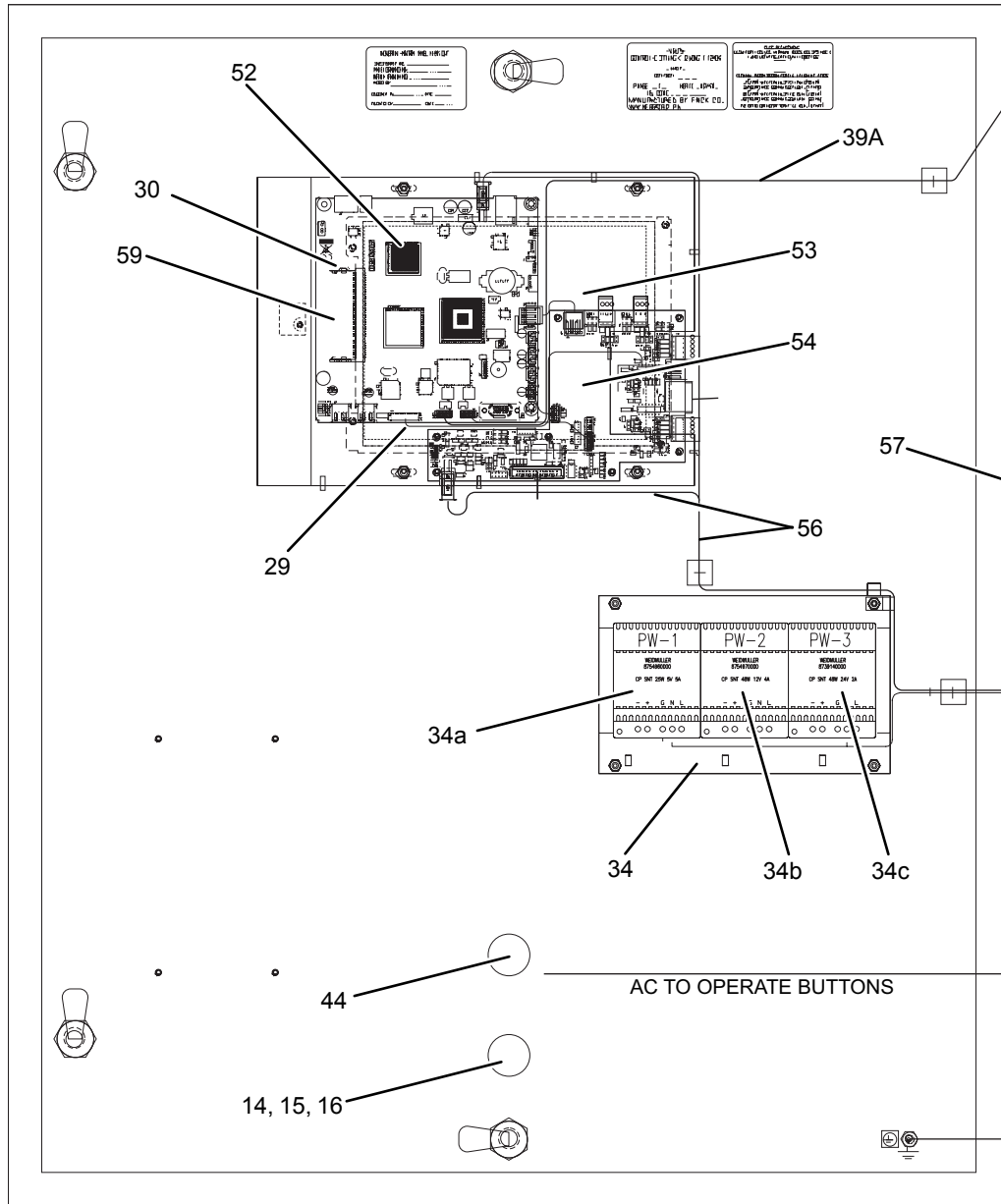

LD15335a

**FIGURE 1 - QUANTUM™ LX BASIC PANEL LAYOUT #1**

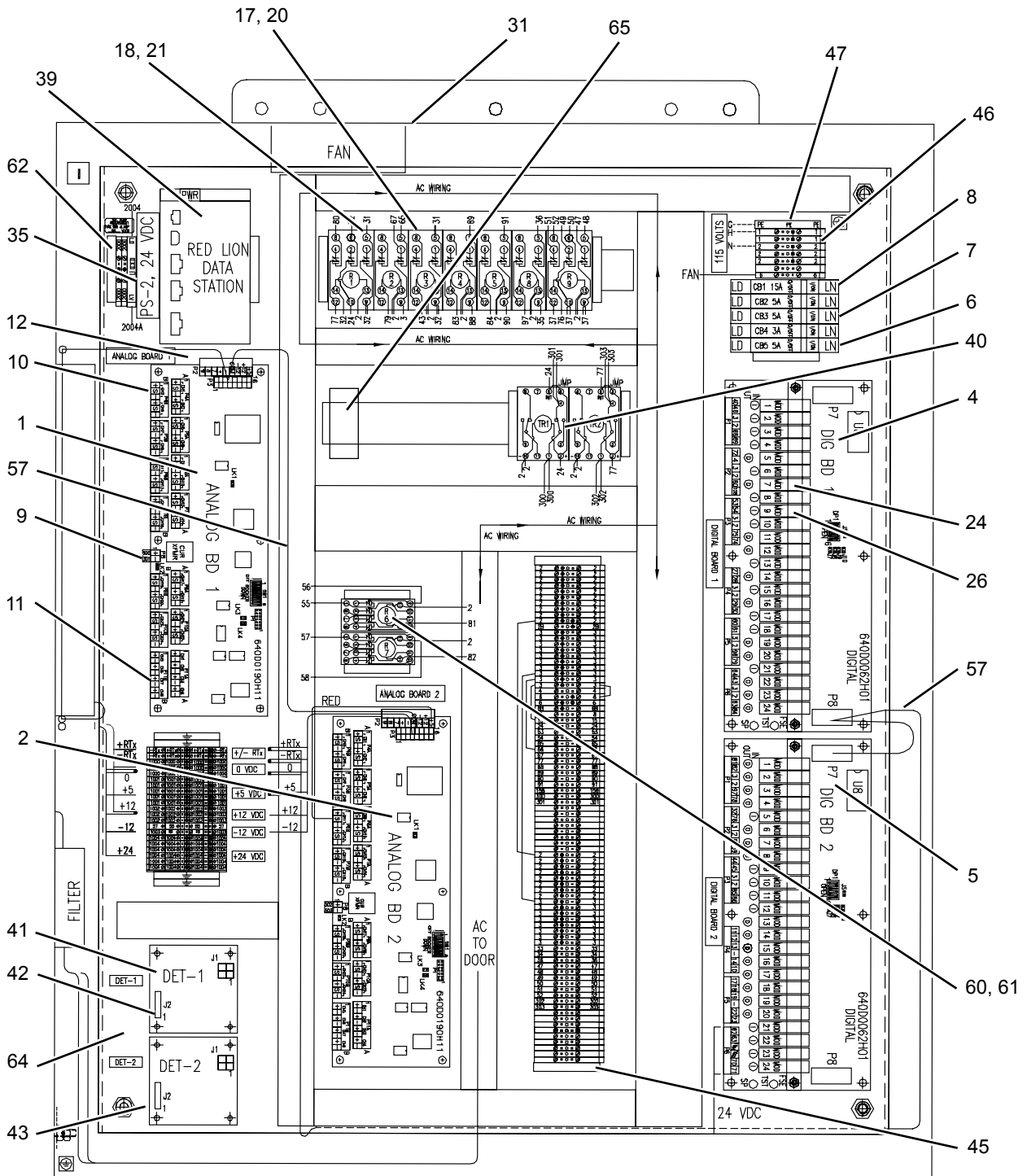

LD15336

FIGURE 2 - QUANTUM™ LX BASIC PANEL LAYOUT #2

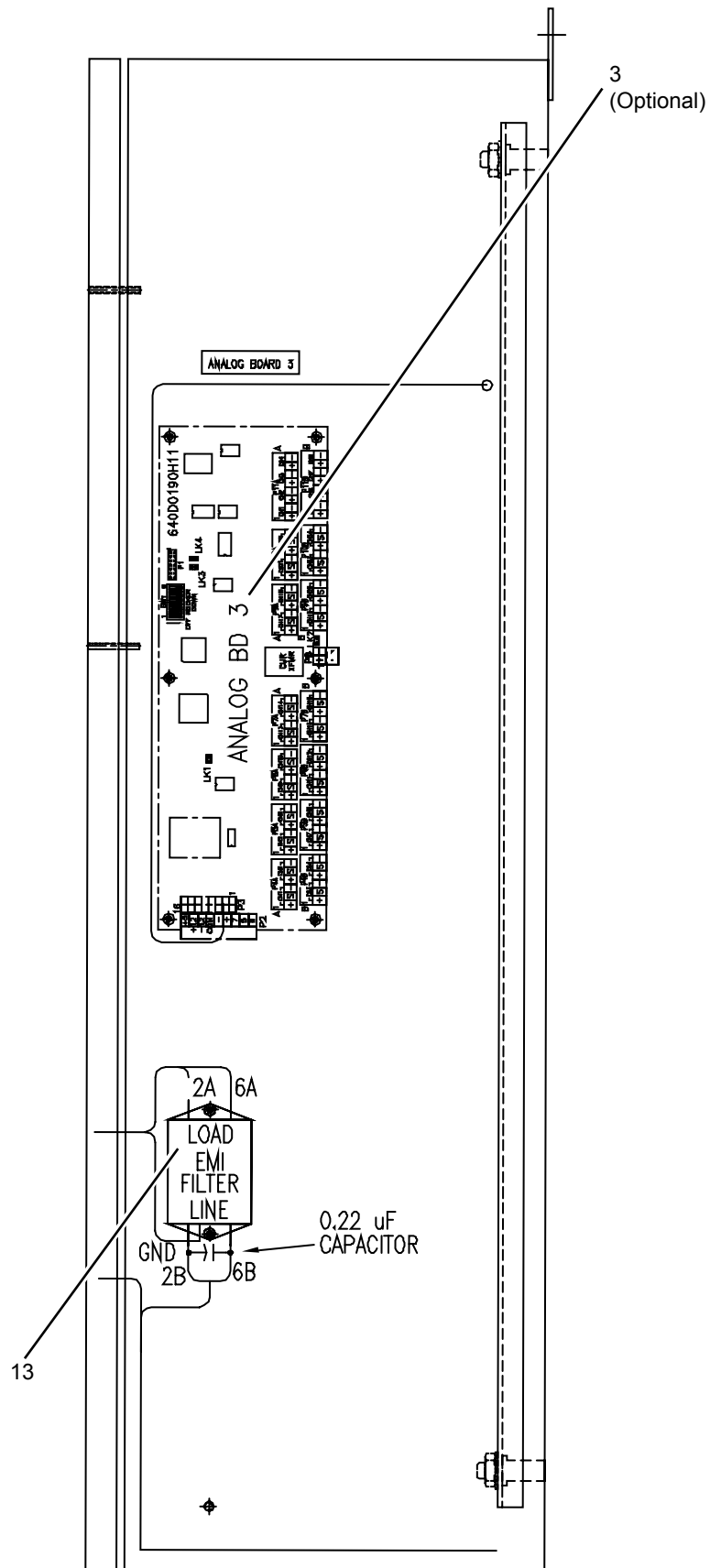

LD15337

**FIGURE 3 - ANALOG BOARD DIAGRAM**

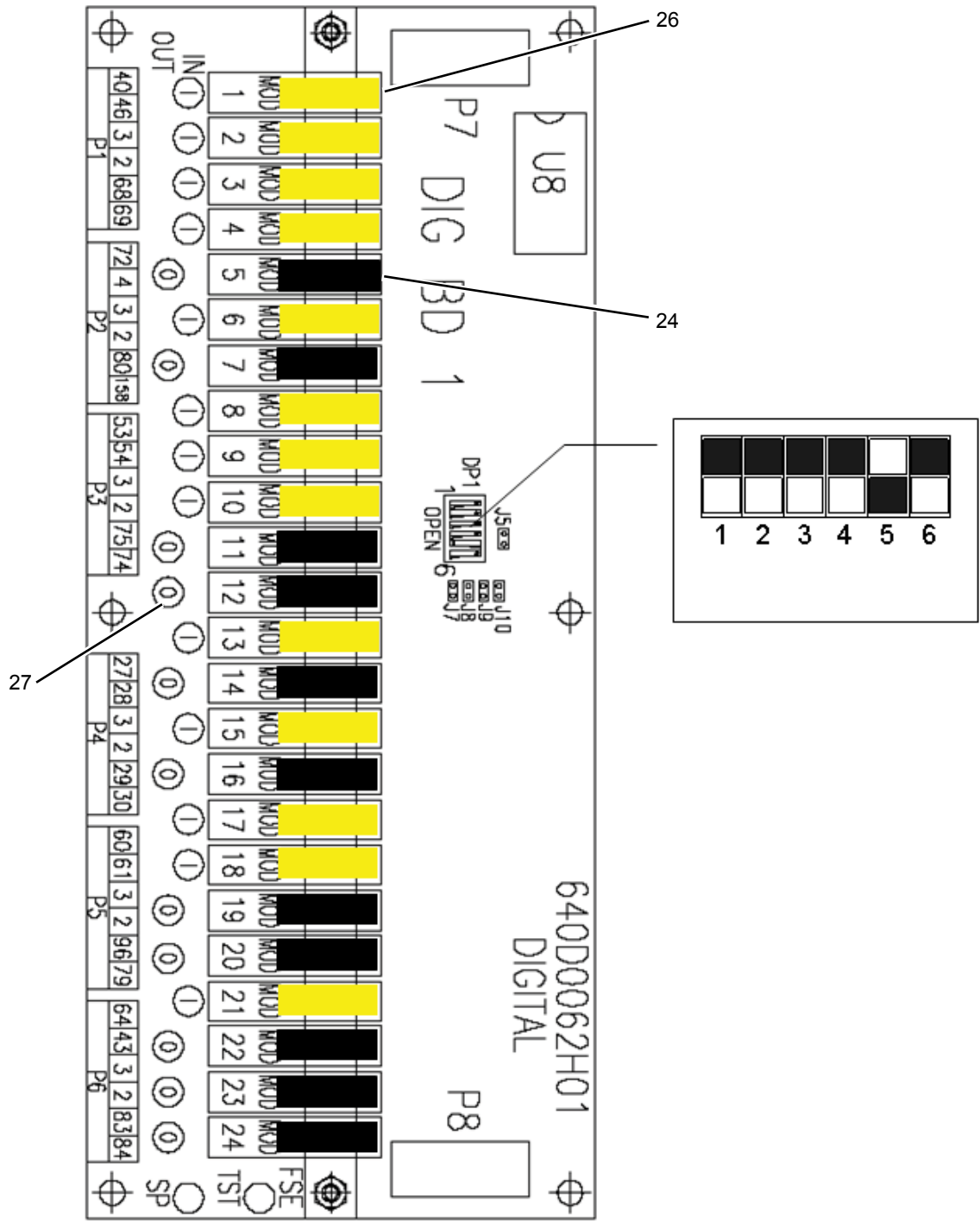

LD15338

FIGURE 4 - DIGITAL BOARD #1



## CONFIGURE THE TIME ON DELAY

The Magnecraft 821TD10H-UNI Universal Timing relay must be configured properly for use. Failure to set this relay properly could result in the damage to the CT (Current Transformer) input channel of the Frick Analog Expansion I/O boards.

- The bottom Function Selector Switch must be set to the A position for DELAY ON MAKE.
- The middle Time Adjustment must be set the time in seconds (+ 5 seconds) that the starter takes to transition from locked rotor amps to full speed run.
- Typical is around 20 second (read on the dial as .33) [~33% of one minute].
- Set the top Range switch to the 1 minute position.

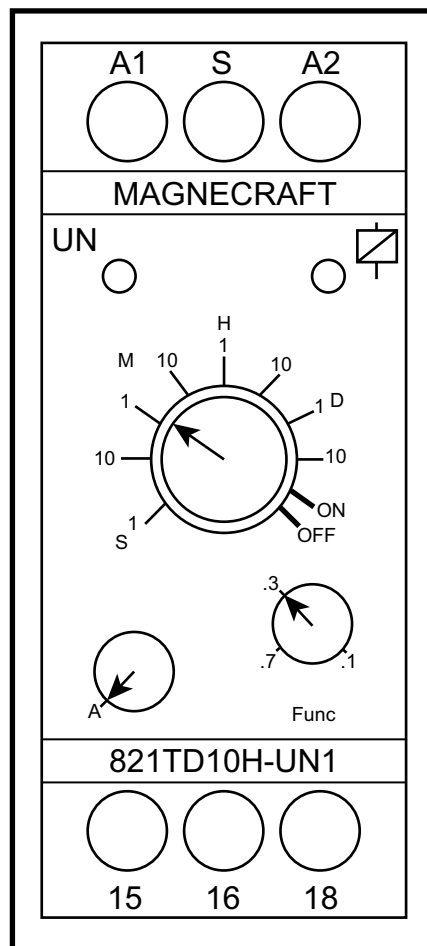

LD15340a

FIGURE 6 - TIME ON DELAY

## VARIABLE SPEED OIL PUMP PANEL

**TABLE 2 - VSOP PANEL PART NUMBERS BY VOLTAGE**

VOLTAGE	FREQUENCY	NEMA CLASS	HP CUTOUT (PSIG)	P/N
200, 208	60	4	211	377 29440 101
220, 230, 240				377 29440 102
380				377 29440 103
440, 460, 480				377 29440 104
500, 550, 575, 600				377 29440 106
416				377 29440 107
346	50	4	211	377 29440 103
380, 400				377 29440 105
415				377 29440 107
200, 208	60	4	315	377 29440 201
220, 230, 240				377 29440 202
380				377 29440 203
440, 460, 480				377 29440 204
500, 550, 575, 600				377 29440 206
416				377 29440 207
346	50	4	315	377 29440 203
380, 400				377 29440 205
415				377 29440 207
200, 208	60	4	373	377 29440 301
220, 230, 240				377 29440 302
380				377 29440 303
440, 460, 480				377 29440 304
500, 550, 575, 600				377 29440 306
416				377 29440 307
346	50	4	373	377 29440 303
380, 400				377 29440 305
415				377 29440 307
440, 460, 480	60	4	418	377 29440-404
380, 400,	50/60	4	418	377 29440-405
415, 416	50/60	4	418	377 29440-406
200, 208	60	4X	211	377 29495 101
220, 230, 240				377 29495 102
380				377 29495 103
440, 460, 480				377 29495 104
500, 550, 575, 600				377 29495 106
416				377 29495 107
346	50	4X	211	377 29495 103
360, 400				377 29495 105
415				377 29495 107
200, 208	60	4X	315	377 29495 201
220, 230, 240				377 29495 202
380				377 29495 203
440, 460, 480				377 29495 204
500, 550, 575, 600				377 29495 206
416				377 29495 207
346	50	4X	315	377 29495 203
380, 400				377 29495 205
415				377 29495 207
200, 208	60	4X	373	377 29495 301
220, 230, 240				377 29495 302
380				377 29495 303
440, 460, 480				377 29495 304
500, 550, 575, 600				377 29495 306
416				377 29495 307
346	50	4X	373	377 29495 303
380, 400				377 29495 305
415				377 29495 307

**TABLE 3 - VSOP POWER PANEL PARTS**

ITEM	USAGE DESCRIPTION	TAG	PART NUMBER	RANGE
101	Variable Speed Oil Pump Drive Unit - 2HP	VSDA, VSDB	024-36133-001 024-36133-002	200v to 346v 440v to 600v
101a	Variable Speed Oil Pump Drive Unit - 5HP* *NOTE: Use <b>only</b> with 377-29440-404 377-29440-405 377-29440-406	VSDA, VSDB	024-39033-002	315v-480v
102	Control Power Transformer Kits	T1	025-29627-001 025-29627-002 025-29627-003 025-29627-004	200v- 208v 220v – 480v 380v – 410v 440v – 600v
105	200v – 240v 346v 380v – 416v 440v – 480v 500v – 600v	FU8, FU9	025-35907-000 025-35905-000 025-30962-000 025-30903-000 025-35902-000	15 amp 10 amp 8 amp 7 amp 6 amp
106	200v – 208v 220v – 240v 346v 380v – 416v 440v – 480v 500v – 600v	FU16, 17, 18	025-35909-000 025-35908-000 025-35907-000 025-35906-000 025-35905-000 025-30962-000	25 amp 20 amp 15 amp 12 amp 10 amp 8 amp
107	200v – 240v 346v – 416v 500v – 600v	FU10, 11, 12, 13, 14, 15	025-35906-000 025-35903-000 025-35901-000	12 amp 7 amp 5 amp
108	High Pressure Cutout Switch (check design working pressure)	PSHH-113A	025-43323-211 025-43323-265 025-43323-275 025-43323-300 025-43323-315 025-43323-373 025-43323-418	211 psig 265 psig 275 psig 300 psig 315 psig 373 psig 418 psig
	Oil Pump Filter Board located in the Oil Sump Junction Box	Filter Board	031-01739-000	

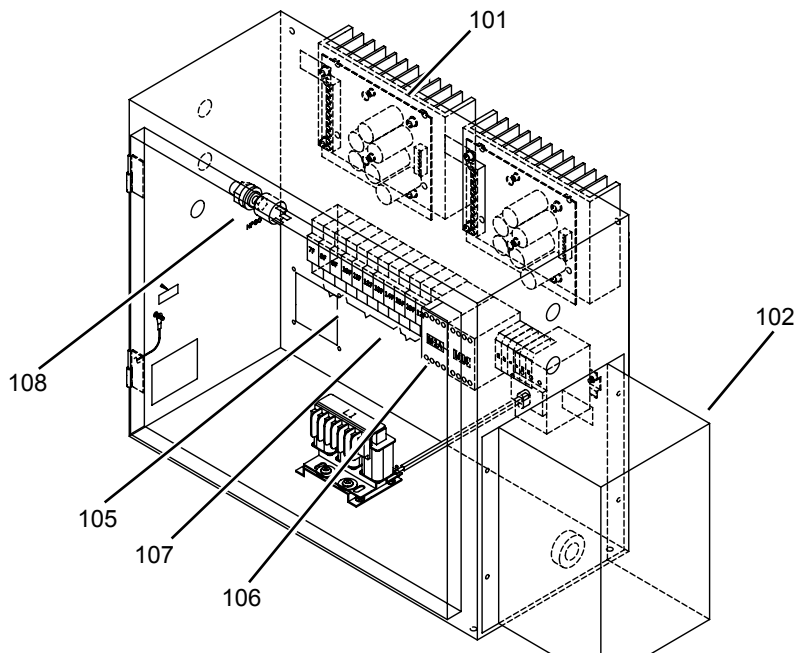

LD15463

**FIGURE 7 - POWER PANEL**

## UNIT MOUNTED INSTRUMENTS

Unit Mounted instruments may be customized for NEMA 4X units in order to meet the installation environment, refer to the project IOM for further documentation.

**TABLE 4 - PRESSURE SENSORS**

ITEM	USAGE DESCRIPTION	TAG	PART NUMBER	RANGE	FIGURE
1	Economizer, Oil Sumps, Oil Pumps Discharge	PE-116, PE-140A, PE-140B	025-28678-006	0-300 psi	8,9
2	Evaporator (Heat Pump)	PE-111	025-28678-115	0-125 psi	8
2a	Evaporator (Ice Storage)	PE-111	025-40312-000	0-100 psia	8
3	Condenser	PE-113,	025-44908-000	0-400 psi	9,10
4	Stall Detector	PE-149A,	025-40088-000	0-300 psi	10
		PE-149B	025-44908-000 025-43790-004	0-400 psi 0-500 psi	

**TABLE 5 - ICTD TEMPERATURE SENSORS**

ITEM	USAGE DESCRIPTION	TAG	PART NUMBER	INSERTION	MATERIAL	FIGURE
5	CYK Water Boxes Standard	TE-100, TE-101, TE-102, TE-103	025-43334-001	~3.0 inch	Brass	9
6		—	025-43334-002	~3.0 inch	304SS	
7	CYK Evaporator Liquid / CYK Subcooler Dropleg	TE-111, TE-114	025-43334-003	~3.0 inch	Brass	9
8			025-43334-004	~3.0 inch	304SS	
9	Replacement Element for -001, -002, -003, -004	—	025-43334-005	~3.0 inch	—	*
10	YK Compressor Discharge / Oil Sump	TE-140A, TE-140B, TE-112A, TE-112B	025-43334-006	~0.5 inch	Brass	9,11
11			025-43334-007	~0.5 inch	304SS	
12	Replacement Element for line -006 and -007	—	025-43334-008	~0.5 inch	—	*
13	Replacement DIN Connector With Cable Seal	—	025-37805-000	—	—	*

**TABLE 6 - LEVEL SENSORS**

ITEM	USAGE DESCRIPTION	TAG	PART NUMBER	LIQUID	FIGURE
13	Subcooler 8" Insertion	LE-114	025-46044-008	Refrigerant	9
13a	Innovative Transmitter Module		025-46338-000	Refrigerant	*
14	Economizer	LE-116	025-40006-000	Refrigerant	8
14a	Hansen Transmitter Module		025-40006-001	Refrigerant	*
15	Oil Sumps	LE-140A, LE-140B	025-40339-000	Oil	9

NOTE: Items with an \* are NOT represented.

**TABLE 7 - MISCELLANEOUS SENSORS**

ITEM	USAGE DESCRIPTION	TAG	PART NUMBER	FIGURE
16	Chilled Liquid Flow, Condenser Liquid Flow	FSSL-101 FSSL-102	025-41573-000	9,10
16a	Replacement Connector 5 Pin Mini	-	025-42799-000	*
17	Proximity Probe Sensor *	ZE-142A ZE-142B	025-40496-001	*
18	Proximity Probe Electronics Module *	ZT-142A	025-40496-002	*
19	Proximity Probe Coax Cable *	ZT-142B	025-40496-003	*
20	Switch, Pressure – Compressor Thrust **	ZS-142A ZS-142B	025-40136-000	*
21	PRV Potentiometer Kit Assembly	ZE-100A ZE-100B	371-02012-001	9,11
22	2500 ohm potentiometer	ZE-149A ZE-149B	025-32570-000	11

\*Applies to these compressor models only – G4, H0, H1, H2, H3, all K, all J, all U

\*\*Applies to these compressor models only – H9, all P, all Q

NOTE: Items with an \* are NOT represented.

**TABLE 8 - ACTUATORS**

ITEM	USAGE DESCRIPTION	TAG	PART NUMBER	FIGURE
23	Hot Gas Actuator	TCV-100C	2" = 025-42245-006 3" and 4" = 025-42245-015	8,9
24	Subcooler Level Actuator Economizer Level Actuator Bypass Level Actuator	LCV-114 LCV-116 LCV-117	2", 2.5", 3" @ 150psi = 025-42245-006 2", 2.5", 3" @ 300psi = 025-42245-009 4" @ 150psi = 025-42245-009 4" @ 300psi = 025-42245-015 5" = 025-42245-015	8,9
25	Interstage Sideload	PCV-116	4" = 025-42246-009 5" and 6" = 025-42246-015 8" = 025-42246-028	8,10
26	LS Large Vane / VGD Actuator	-	025-29657-001	8,11
27	Small Vane / VGD Actuator	-	025-17175-001	8,11
28	LS - K7 HS - U1, U2 Vane / VGD Actuator	-	025-40490-001	8,11
28a	U3, U4, Linear Actuator Vane / VGD		025-47366-000	8.11
29	Bleed Solenoid Assembly Replacement Coil Valve Rebuild Kit	PCV-117	025-40449-000 025-40449-102 025-40449-101	8,10
30	Oil Return Refrigerant Liquid Solenoid Assembly Replacement Coil Replacement Valve Body	FCV-140A	025-35150-001 025-37841-001 025-37840-001	8
31	Liquid Injection Refrigerant Liquid Solenoid Replacement Coil Valve Rebuild Kit	FCV-113A, FCV-113B	025-35150-002 025-37841-001 025-37840-001	8,9

**TABLE 8 - ACTUATORS (CONT'D)**

ITEM	USAGE DESCRIPTION	TAG	PART NUMBER	FIGURE
	Male DIN Connector with 1/2" conduit thread used on Actuators (replacement)	–	025-40232-000	*
	Female DIN Connector for 1/2" conduit used on harnesses	–	025-37876-000	*

**TABLE 9 - CURRENT TRANSFORMERS**

PART NUMBER	VOLTAGE RANGE	RANGE
025-43358-000	High / 15kv	50:1
025-29469-000	Low / Medium / High	200:1
025-32191-000	15kv	200:1
025-21173-002	Low / Medium	350:1
025-32234-000	High	350:1
025-21173-003	Low	700:1
025-21173-005	Medium	700:1
025-21173-004	Low	1400:1
025-21173-011	Medium	1400:1

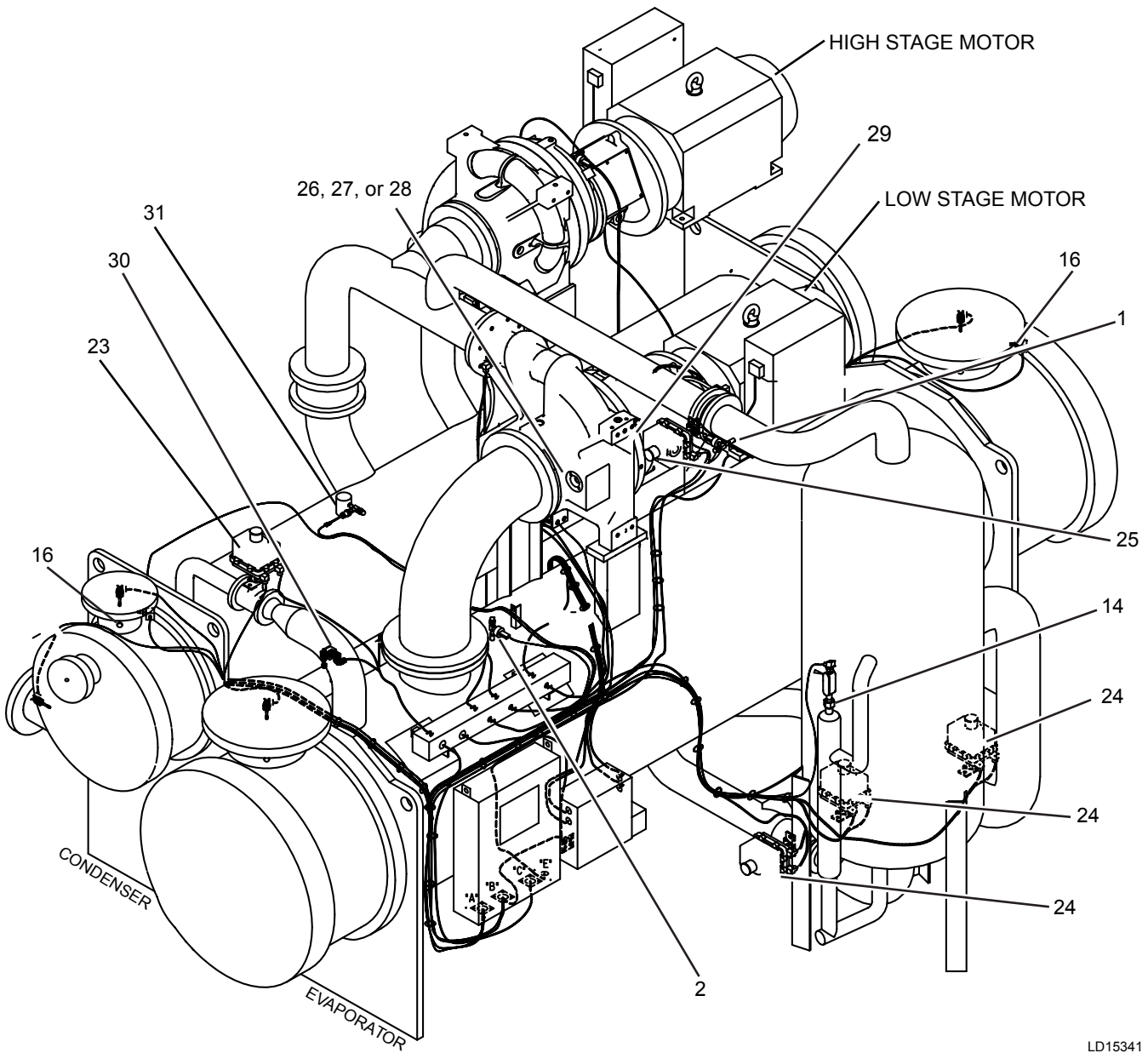

LD15341

**FIGURE 8 - SYSTEM COMPOUND CYK CHILLER (FRONT VIEW)**

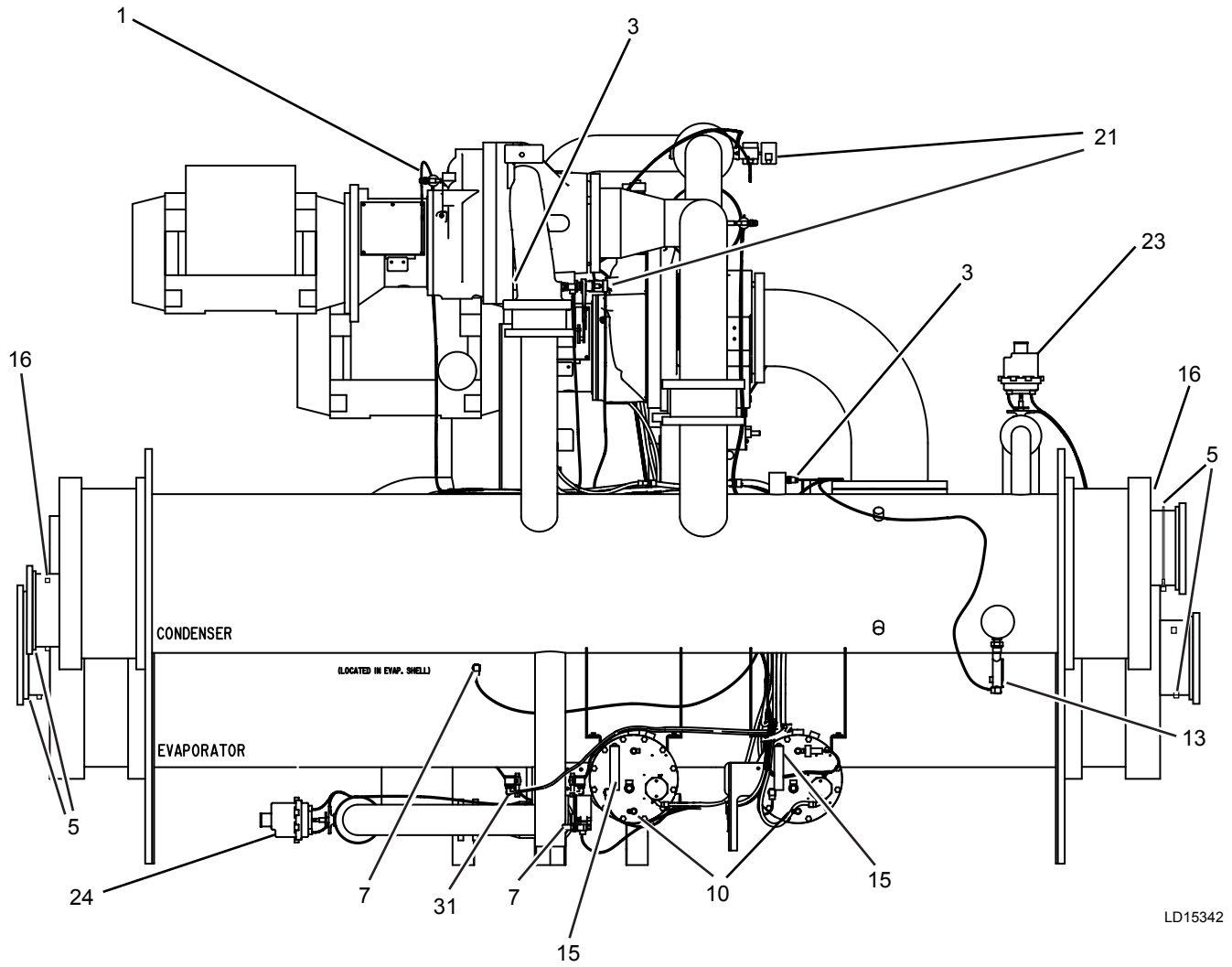

LD15342

**FIGURE 9 - SYSTEM COMPOUND CYK CHILLER (SIDE VIEW)**

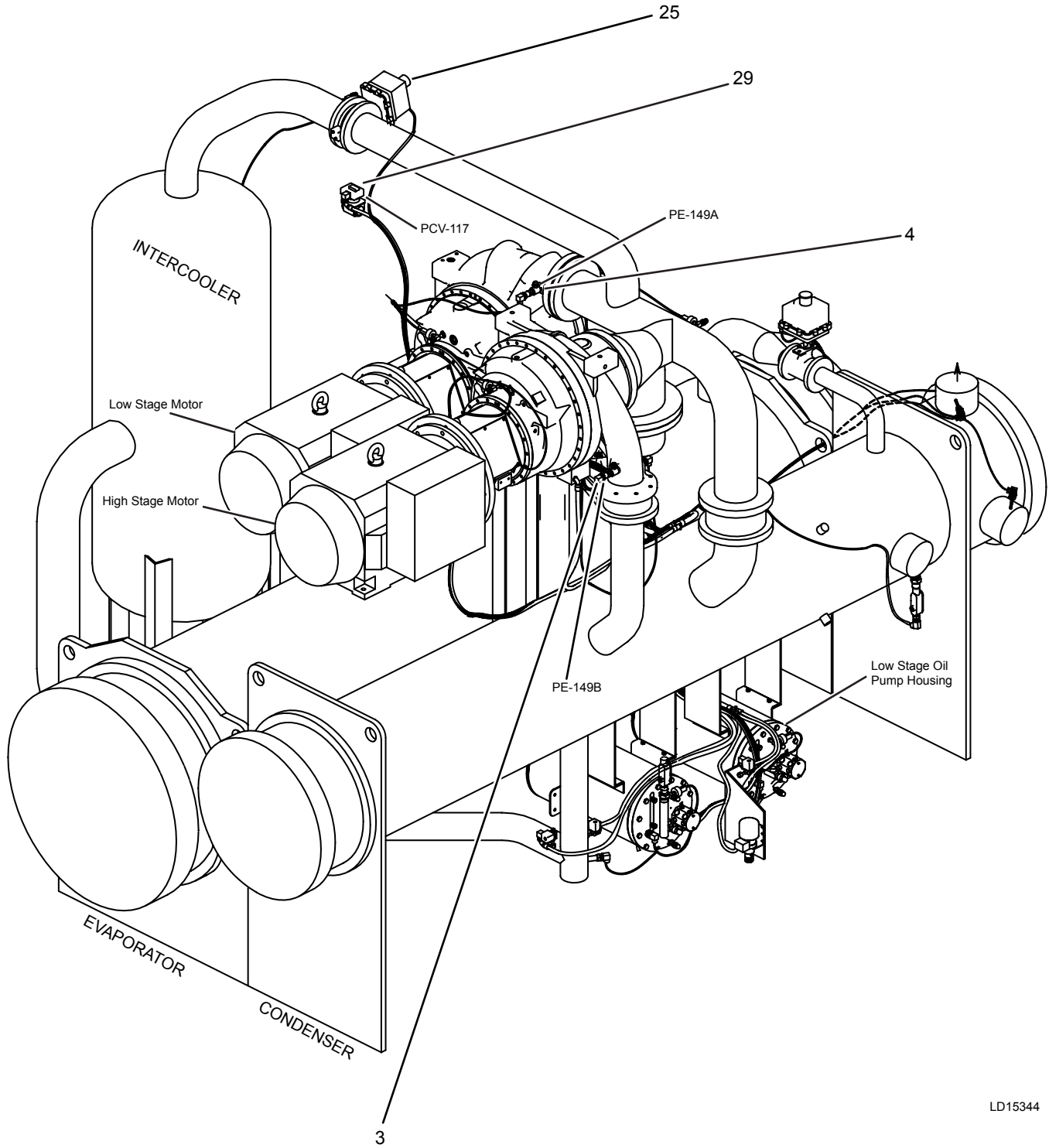

**FIGURE 10 - SYSTEM COMPOUND CYK CHILLER (REAR VIEW)**

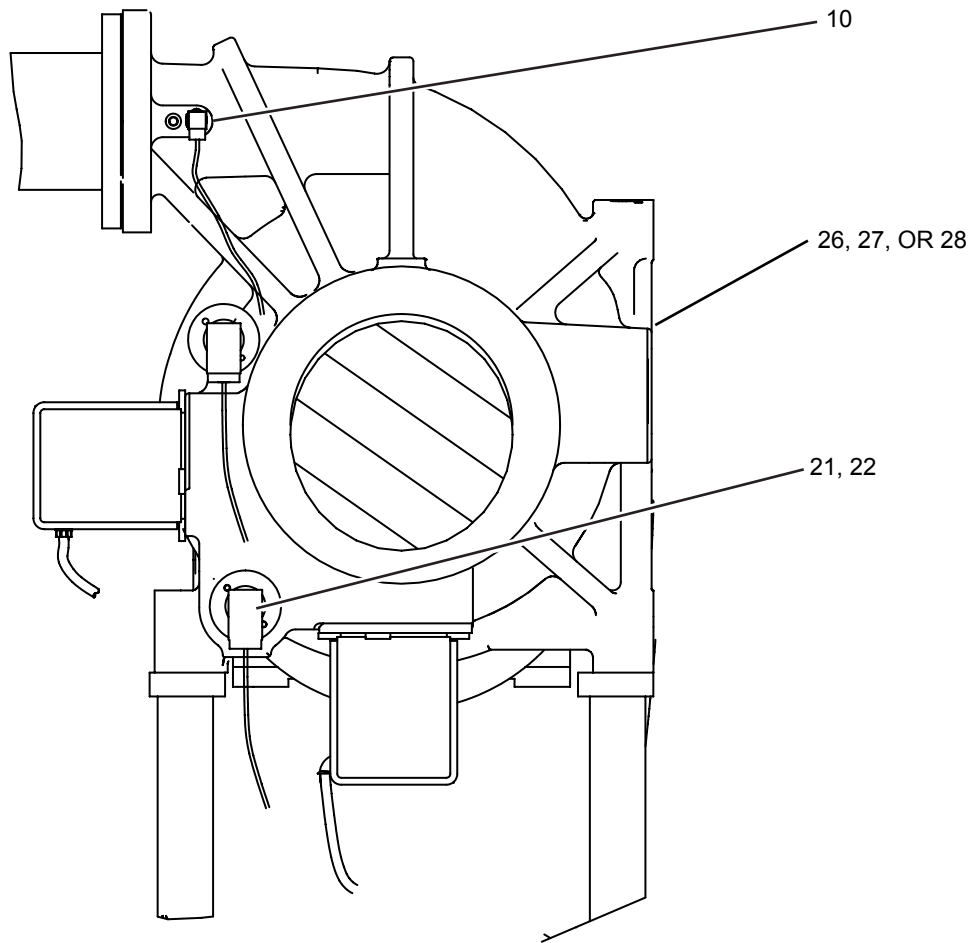

LD15343

**FIGURE 11 - LOW STAGE COMPRESSOR**



P.O. Box 1592, York, Pennsylvania USA 17405-1592  
Copyright © by Johnson Controls 2016

Form 160.82-RP1 (816)  
Issue Date: August 9, 2016)  
Supersedes: 160.82-RP1 (513)

800-861-1001  
[www.johnsoncontrols.com](http://www.johnsoncontrols.com)

Subject to change without notice. Printed in USA  
ALL RIGHTS RESERVED