



COMPOUND YK CENTRIFUGAL LIQUID CHILLER

OPERATION AND MAINTENANCE

Supersedes: 160.82-OM1 (611)

Form 160.82-OM1 (813)

MODEL CYK CENTRIFUGAL CHILLER / HEAT PUMP SYSTEM WITH QUANTUM™ LX CONTROLS



LD15345

R-134a

Issue Date:
August 30, 2013



IMPORTANT!

READ BEFORE PROCEEDING!

GENERAL SAFETY GUIDELINES

This equipment is a relatively complicated apparatus. During installation, operation maintenance or service, individuals may be exposed to certain components or conditions including, but not limited to: refrigerants, materials under pressure, rotating components, and both high and low voltage. Each of these items has the potential, if misused or handled improperly, to cause bodily injury or death. It is the obligation and responsibility of operating/service personnel to identify and recognize these inherent hazards, protect themselves, and proceed safely in completing their tasks. Failure to comply with any of these requirements could result in serious damage to the equipment and the property in

which it is situated, as well as severe personal injury or death to themselves and people at the site.

This document is intended for use by owner-authorized operating/service personnel. It is expected that these individual possess independent training that will enable them to perform their assigned tasks properly and safely. It is essential that, prior to performing any task on this equipment, this individual shall have read and understood this document and any referenced materials. This individual shall also be familiar with and comply with all applicable governmental standards and regulations pertaining to the task in question.

SAFETY SYMBOLS

The following symbols are used in this document to alert the reader to specific situations:



Indicates a possible hazardous situation which will result in death or serious injury if proper care is not taken.



Identifies a hazard which could lead to damage to the machine, damage to other equipment and/or environmental pollution if proper care is not taken or instructions are not followed.



Indicates a potentially hazardous situation which will result in possible injuries or damage to equipment if proper care is not taken.

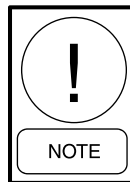

Highlights additional information useful to the technician in completing the work being performed properly.



External wiring, unless specified as an optional connection in the manufacturer's product line, is not to be connected inside the Quantum™ LX cabinet. Devices such as relays, switches, transducers and controls and any external wiring must not be installed inside the micro panel. All wiring must be in accordance with Johnson Controls' published specifications and must be performed only by a qualified electrician. Johnson Controls will NOT be responsible for damage/problems resulting from improper connections to the controls or application of improper control signals. Failure to follow this warning will void the manufacturer's warranty and cause serious damage to property or personal injury.

CHANGEABILITY OF THIS DOCUMENT

In complying with Johnson Controls' policy for continuous product improvement, the information contained in this document is subject to change without notice. Johnson Controls makes no commitment to update or provide current information automatically to the manual owner. Updated manuals, if applicable, can be obtained by contacting the nearest Johnson Controls Service office or accessing the Johnson Controls QuickLIT website at <http://cgproducts.johnsoncontrols.com>.

Operating/service personnel maintain responsibility for the applicability of these documents to the equipment. If there is any question regarding the applicability of

these documents, the technician should verify whether the equipment has been modified and if current literature is available from the owner of the equipment prior to performing any work on the chiller.

CHANGE BARS

Revisions made to this document are indicated with a line along the left or right hand column in the area the revision was made. These revisions are to technical information and any other changes in spelling, grammar or formatting are not included.

ASSOCIATED LITERATURE

MANUAL DESCRIPTION	FORM NUMBER
Renewal Parts	160.82-RP1
Startup Checklist	160.82-CL1
Wiring Diagrams	160.82-PW1

NOMENCLATURE

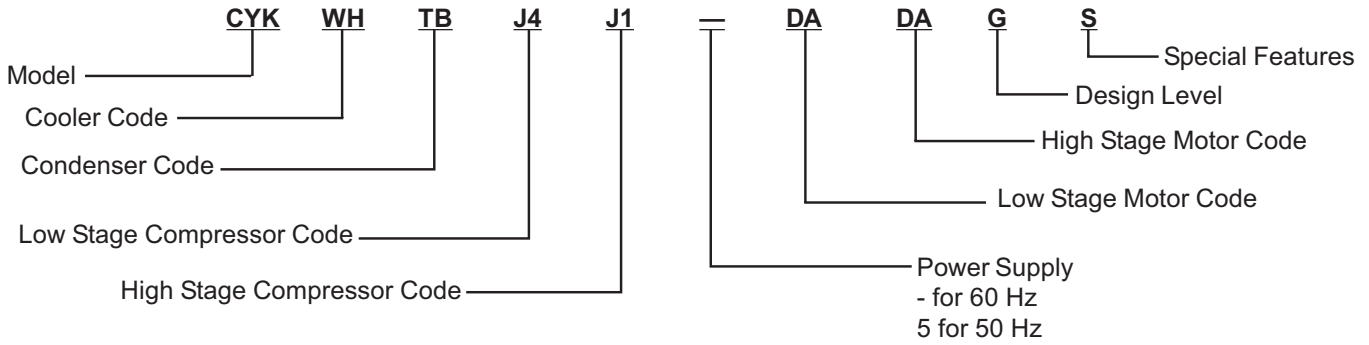

TABLE OF CONTENTS

SECTION 1 - DESCRIPTION OF SYSTEM	9
SECTION 2 - FUNDAMENTALS OF OPERATION	33
SECTION 3 - QUANTUM LX CONTROL PANEL	55
Home Screen	63
System Screen	65
Evaporator Screen	67
Condenser Screen	69
Subcooler Screen	71
Hot Gas Screen	73
Low Stage Compressor Screen	75
LS Proximitor Calibration (Low And High Stages) Screen	77
PRV Calibration Screen	79
Oil Sump (Unified Sump Pressure) Screen	81
Oil Sump (Ice Thermal Storage) Screen	83
LS Variable Geometry Diffuser Screen	87
High Stage Compressor Screen.....	89
HS Proximitor Calibration Screen	91
Liquid Cooled Solid State Starter (Optional).....	93
Capacity Controls Screen.....	96
Manual Auto Station (Capacity Controls) Screen.....	98
PID Tuning Screen.....	100
Overrides Screen	102
Anti-Surge Screen.....	104
Setup Screen.....	106
Test Outputs Screen	108
Setpoints 1 Screen.....	109
Setpoints 2 Screen.....	110
Pressure Calibration Screen	113
Temperature Calibration Screen	114
Miscellaneous Calibration Screen.....	115
Digital Input Configuration Screen	117
Digital Output Configuration Screen	118
Auxiliary Analog Configuration Screen.....	119
Auxiliary Analog Calibration Screen, Page 1	121
Auxiliary Analog Calibration Screen, Page 2	122
Retransmitting Outputs Screen.....	123
Economizer Screen	124
History Screen	126
Freeze Screen	127
Trending Screen.....	128
Trending Setup Screen	130
Custom Display Screen	131
SECTION 4 - SOFTWARE UPDATE PROCEDURE	133
SECTION 5 - SYSTEM COMMUNICATION AND NETWORKING	137
SECTION 6 - TROUBLESHOOTING	181

LIST OF FIGURES

FIGURE 1 - Main Controller Board and Peripherals.....	13
FIGURE 2 - Quantum™ LX Jumper Settings.....	14
FIGURE 3 - Quantum™ LX 5 Motherboard Power Connector Pinout.....	14
FIGURE 4 - Quantum LX Interface Board.....	15
FIGURE 5 - Quantum LX Interconnections.....	16
FIGURE 6 - Power Supplies.....	17
FIGURE 7 - Potentiometer Adjustment.....	18
FIGURE 8 - Digital Input Modules.....	20
FIGURE 9 - DIO Connector Plug.....	21
FIGURE 10 - Digital Board #1.....	23
FIGURE 11 - Digital Board #2.....	24
FIGURE 12 - Potentiometer Adjustment.....	26
FIGURE 13 - Analog Outputs.....	28
FIGURE 14 - Motor Amps.....	29
FIGURE 15 - Enhanced Analog Board Diagram.....	30
FIGURE 16 - Quantum™ LX Keypad.....	33
FIGURE 17 - Quantum™ LX Basic Panel Layout.....	34
FIGURE 18 - General Operating Sequence.....	35
FIGURE 19 - System Status.....	36
FIGURE 20 - Control Model.....	40
FIGURE 21 - Valve Locations.....	44
FIGURE 22 - System Anti-Surge.....	46
FIGURE 23 - Parameters For Anti-Surge.....	46
FIGURE 24 - Stage Operations.....	47
FIGURE 25 - Capacity Control Diagrams.....	51
FIGURE 26 - Quantum™ LX Graphic Display.....	55
FIGURE 27 - Allowable Range.....	57
FIGURE 28 - Manual Automatic Stations.....	59
FIGURE 29 - Control Center.....	61
FIGURE 30 - Home Screen.....	63
FIGURE 31 - System Screen.....	65
FIGURE 32 - Evaporator Screen.....	67
FIGURE 33 - Condenser Screen.....	69
FIGURE 34 - Subcooler Screen.....	71
FIGURE 35 - Hot Gas Screen.....	73
FIGURE 36 - Low Stage Compressor Screen.....	75
FIGURE 37 - LS Proximitor Calibration (Low And High Stages) Screen.....	77
FIGURE 38 - PRV Calibration Screen.....	79
FIGURE 39 - PRV Position Sensor.....	79
FIGURE 40 - Oil Sump (Unified Sump Pressure) Screen.....	81
FIGURE 41 - Oil Sump (Ice Thermal Storage) Screen.....	83
FIGURE 42 - Low Stage Oil Return Eductor.....	84
FIGURE 43 - High Stage Oil Return Eductor.....	85
FIGURE 44 - Oil Level Sensor.....	86
FIGURE 45 - High Stage Oil Sump.....	86
FIGURE 46 - LS Variable Geometry Diffuser Screen.....	87
FIGURE 47 - High Stage Compressor Screen.....	89
FIGURE 48 - HS Proximity Calibration Screen.....	91
FIGURE 49 - Liquid Cooled Solid State Starter (Optional).....	93
FIGURE 50 - Chiller Mode.....	96
FIGURE 51 - Heat Pump Mode.....	97
FIGURE 52 - Manual Auto Station (Capacity Controls) Screen.....	98
FIGURE 53 - PID Tuning Screen.....	100
FIGURE 54 - Overrides Screen.....	102

LIST OF FIGURES (CONT'D)

FIGURE 55 - Temperature-Based Demand Limiter Function	103
FIGURE 56 - Anti-Surge Screen.....	104
FIGURE 57 - Setup Screen	106
FIGURE 58 - Test Outputs Screen	108
FIGURE 59 - Setpoints 1 Screen	109
FIGURE 60 - Setpoints 2 Screen	110
FIGURE 61 - HS PRV Offset Control Scale Function	111
FIGURE 62 - Pressure Calibration Screen.....	113
FIGURE 63 - TemperaTure Calibration Screen	114
FIGURE 64 - Miscellaneous Calibration Screen	115
FIGURE 65 - Flow Instruments Wiring	116
FIGURE 66 - Digital Input Configuration Screen	117
FIGURE 67 - Digital Output Configuration Screen	118
FIGURE 68 - Auxiliary Analog Configuration Screen.....	119
FIGURE 69 - Auxiliary Analog Input Safeties Screen.....	119
FIGURE 70 - Auxiliary Analog Calibration, Page 1.....	121
FIGURE 71 - Auxiliary Analog Calibration, Page 2.....	122
FIGURE 72 - Retransmitting Outputs Screen.....	123
FIGURE 73 - Economizer Screen	124
FIGURE 74 - History Screen	126
FIGURE 75 - Freeze Screen	127
FIGURE 76 - Trending Screen	128
FIGURE 77 - Real Time Trending Screen	129
FIGURE 78 - Trending Setup Screen	130
FIGURE 79 - Custom Display Screen	131
FIGURE 80 - USB Flash Drive	135
FIGURE 81 - Ethernet Connection.....	137
FIGURE 82 - Typical RJ-45 Connector	138
FIGURE 83 - Crossover cable.....	139
FIGURE 84 - Typical Switch	139
FIGURE 85 - Ethernet Setup.....	141
FIGURE 86 - Serial Port Locations.....	144
FIGURE 87 - Communications Setup.....	145
FIGURE 88 - Communications Data Logging Screens	148
FIGURE 89 - ModBus TCP Communications Log.....	149
FIGURE 90 - How the Data Packets are Created	149
FIGURE 91 - Data Station Pinout.....	150
FIGURE 92 - Virtual HMI	151
FIGURE 93 - BACnet IP Over Ethernet.....	151
FIGURE 94 - BACnet MSTP Over RS-485	152
FIGURE 95 - RJ-45 Connector.....	152
FIGURE 96 - MODBUS RTU or AB DF1 Over RS-485	153
FIGURE 97 - Create Your Own	153

LIST OF TABLES

TABLE 1 - Communications Settings	25
TABLE 2 - Dipswitch Settings	25
TABLE 3 - Enhanced Analog Board Input Configuration Table	27
TABLE 4 - Communications	31
TABLE 5 - Current Transformer (CT)	31
TABLE 6 - Dipswitch Settings (Used to set the board address).....	31
TABLE 7 - Analog Board	31
TABLE 8 - System Details.....	60
TABLE 9 - Full Load Amps	94
TABLE 10 - Start Current	94
TABLE 11 - Ethernet Component Recommendations.....	140
TABLE 12 - Serial Communication Setup	146
TABLE 13 - Communications Board	147
TABLE 14 - Quantum LX for CYK Protocol List.....	155
TABLE 15 - List Alarm Codes	175
TABLE 16 - SI Metric Conversion	183

SECTION 1 - DESCRIPTION OF SYSTEM

The Quantum™ LX system is a fully integrated control system for Compound YK chillers. The versatility of the CYK product allows it to be used as either a chiller or a heat pump application as a standard option. The advanced CYK control system manages all aspects of chiller operation, monitoring vital parameters and making real-time adjustments as necessary to ensure safe and efficient operation of primary system components.

A full-color, animated graphic operator interface provides the operator access to all real-time sensor data, and is equipped with both sensor history logging and complete alarm/system trip history features. Manual adjustments to operational parameters may be made by a qualified service technician. Among the monitored operating parameters are:

- Chilled liquid temperatures
- Refrigerant pressures and temperatures
- Cooling liquid temperatures
- Compressor data
- Pre-rotation vane positions
- Evaporator data
- Condenser data
- Subcooler data
- Oil pump pressures
- Motor Load
- General system data and data trending

The system setpoints are operator entered and include:

- Local Chilled liquid temperature setpoint
- Remote setpoint temperature
- Percent load limit
- Clock

Additional modifications may be made to system PID tuning. All data and control features are accessible from the operator interface display. The system is also accessible across an Ethernet LAN through a standard web browser.

SYSTEM ARCHITECTURE

The Quantum™ LX control panel contains all of the necessary control hardware and software within one self contained enclosure, and is mounted to the chiller package. The front of this control enclosure contains a graphic display and keypad, to allow the operator to access various system information and to make necessary adjustments to setpoints, calibrations and features.

Operator access to this system is through various screens. A screen is the physical representation of data on the display. Each screen has a title area. The title is descriptive of the screen. The current date and time is shown as well as the day of the week, Sunday (Sun.) through Saturday (Sat.) is displayed in the title area. The month of the year from January (Jan.) to December (Dec.) is displayed. The day of the month from 1 to 31 and the year from 0001 to 9999 is displayed. Time is displayed in military 24 hours format. The hours, minutes and seconds.

Some screens are for informational purposes only, and cannot be modified. These screens typically show analog values such as temperature and pressure, which are strictly functions of an associated sensor, and as such, cannot be modified. Other screens show setpoint values which can be changed, in order modify the units operating characteristics. For easier viewing, related information is separated into boxes. Sometimes selections are hidden when that the feature is unavailable.

Quantum™ LX control system consists of five major areas:

- **Quantum™ LX Controller** – The Quantum™ LX runs a software program that communicates with all of the digital and analog boards. This communication allows the Quantum™ LX to read the status of all the I/O boards, and display the data on the interface screen. The Quantum™ LX acts on this data, and provides the necessary control information to the I/O boards to provide the appropriate control of all input and output signals, based upon the configuration of installed features and options of the compressor package.
- Operator interaction is provided through the keypad, as well as informational status to the display. Interaction to the outside world is provided

through industry-standard communications protocols. Additional information about the Quantum™ LX can be found under the QUANTUM™ LX CONTROLLER section in this manual.

- **Power Supply** – Provides the necessary operating voltages for the proper operation of all control components. Additional information about the power supply can be found under the POWER SUPPLY section in this manual.

The DC power/communications harness in this panel is color-coded to make wire identification easier. The color coding is as follows:

- +5VDC - Red
 - +12VDC - Yellow
 - +24VDC – Dark Blue
 - Common/Ground - Black
 - +RX/TX – White with Red
 - -RX/TX – White w/ Black stripe
- **Digital Input / Output Boards** – Digital (on/off) signals are sent and received by these boards. The output signals are used for energizing solenoids, valves, contactors, relays, etc., and the input signals are used to sense the condition of switches, relay contacts, auxiliary contacts, etc. This board runs an independent software program from the Quantum™ LX to control devices, and communicates the status of all devices back to the Quantum™ LX. Additional information about the Digital Boards can be found under the DIGITAL BOARD section in this manual.
 - **Analog Input / Output Boards** – Analog (variable) signals are sent and received by these boards. The output signals are used for controlling damper motors, modulated valves, etc., and the input signals are used to read the values being sent from pressure transducers, temperature sensors, etc. This board runs an independent software program from the Quantum™ LX to control devices, and communicates the status of all devices back to the Quantum™ LX. The analog board has 24 analog inputs and 8 analog outputs.
 - **Operator Interface** – This section actually consists of two major components; the display and the keypad. The display is used to show the operator, via a graphical interface, the actual status of all compressor values. Warnings and shutdowns (and

history/trending), pressure and temperature values, digital I/O status, setpoints, etc. are viewed from this display. The Keypad is used by the operator to enter data such as setpoint values, calibration data, etc. into the Quantum™ LX controller. Additional information about the display can be found under the DISPLAY section in this manual.

Quantum™ LX Controller Board

Troubleshooting the Quantum™ LX Control Panel

This section contains information on troubleshooting and making corrections to the boards and control circuits of the Quantum™ LX.

General Information

The components within the control panel are sensitive and can be damaged by static electricity or mishandling. Only qualified technicians should directly handle these components.

- DO NOT attempt to make corrections to the power supply without shutting off the power to the control panel. Accidental shorts can irreparably damage the processor boards or the display screen.
- DO NOT handle the panel boards when the cables are disconnected without first attaching a properly grounded wrist ground strap to your body that will prevent static electrical discharge. Most problems encountered with the microprocessor and control circuits will be the result of a wiring fault, a blown fuse, faulty I/O module or failure of a peripheral control such as a solenoid coil or a pressure transducer.

Faults in the computer, while possible, are unlikely. If a fault develops in the computer, the probability is that all functions will cease and the display screen will go blank.

The control system of the compressor consists of an AC (high voltage) side, which is 120 volts, and a DC (low voltage) side. The AC side actuates solenoids, relays, alarms, and other electromechanical functions. The DC side operates the computer and its various sensors.



When working within the panel, the AC high voltage side, which is nominal 120 VAC and CAN CAUSE INJURY OR DEATH.

To troubleshoot the low-voltage side of the control circuits, it is necessary to have the following tools:

1. Accurate digital multimeter (capable of reading to DC/AC, mA to the hundreds place).
2. Small wire stripper.
3. Small screwdriver (with insulated shaft).
4. Small snip nose pliers.
5. Wrist Grounding strap.
6. Static free grounded work surface.

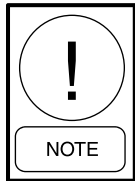

Proper panel voltage refers to the AC (high voltage) that has been supplied to the panel, which could be either nominal 120 VAC (Reference the Control Panel Power Specifications).

Some problems that are encountered involve troubleshooting the digital inputs and outputs. The Digital I/O (Input/Output) boards have six Digital I/O (DIO) board connectors labeled P1 through P6. The input and output modules are wired into a DIO connector plug. Position 3 provides power and position 4 is a neutral on the DIO connectors.

What To Do Before Calling for Service

Before calling for service, review the information on the following pages and try to discover and resolve the Quantum™ LX problem. The actual cause of most problems is usually not with the Quantum™ LX itself, but with something external to the panel. However, on the rare occasion that the problem has been identified as being the Quantum™ LX controller, use the following section as a guideline for servicing the panel. A blank screen could be the result of many different problems. Following is a list of possible reasons for no display:

- No power
- Loose or Faulty Display Cable or Inverter Cable
- Bad Display
- Bad Backlight Inverter
- Bad Backlight Fluorescent Tube
- Wrong Combination of Display, Cable, Inverter, or Software
- Faulty CPU Board

Replacing the Quantum™ LX Controller Board

Flash Card memory load is done prior to the board being shipped. The customer needs to have their settings manually recorded, or saved to a Flash Card, so that the new board can be setup the same as the old one. It is suggested that the operator first record all control setpoints prior to board replacement. Factory Setup settings will also be lost. The Setpoint Data sheets later in this manual are useful for recording this information. A Maintenance Flashcard may also be purchased that will allow these setpoints to be saved electronically, and may be downloaded at a later time (Refer to the Renewal Parts Manual).

The procedure to replace the Quantum™ LX is outlined below:

1. Shut off control power.
2. Remove the old board from the machine and the new board from its packing and place both on an anti-static surface.
3. Ensure that the jumpers on the new board are set the same as those on the old board.
4. Install the flash card from the old board to the replacement board.
5. Install the modified replacement board into the panel.
6. If program changes are necessary through the USB port download, then follow the directions in the Software Maintenance section of this manual for the procedure to reload a program.
7. Power the panel up, and set the date and time.

What Should Occur When Applying Power

When powering up the Quantum™ LX, the following sequence of events are indicative of a properly working main processor board:

- There are LED's on the main Quantum™ LX for CYK controller board.
- PWR (Power) LED will turn on solid on the Keypad Interface Board. This should be an indication that the board has received power.
- The ACT (Active) LED will blink on the Keypad Interface Board.
- The boot sequence will show the CMOS boot information briefly on the display.

- Once the board begins to boot the operating system “TUX” penguin icons will appear briefly in the top left corner.
- The HOME screen will appear on the display once the control application has started.
- The RX/TX lights of the Analog and Digital boards will also flash.

After the Quantum™ LX has properly powered up, the following sequence of events is indicative of proper communication to the analog and digital boards:

- The TX/RX LED's near the white connector will begin to blink.
- The Analog and Digital I/O boards TX/RX lights should be blinking.
- Each I/O board should have the power LED (next to the white connector) lighted and the active LED (next to the blue Dipswitch) should be blinking.

What If The CYK “Home” Status Screen Is Not Shown

If the Operating Status screen is not shown, check the following items:

1. If no LED's on the Keypad Interface board are lit, then check AC and DC power with a Multimeter.
2. Check if the lighting of the LED's is occurring as described in the What Should Occur When Applying Powering section. If the powering up sequence continues to repeat without displaying the HOME status screen, then there is a booting problem.
3. Check if an error message is displayed when booting. Be sure to write down any error messages exactly as they appear.
4. Check that the software is OK:
 - Is the correct software installed?
 - Did you just install new software?
 - If you need to clear the numerical setpoint and calibration areas of memory for any reason, clear the memory as described in the Software Maintenance section of this manual.
 - NOTE: This information will be replaced by factory default values, so any setpoint and calibration data values that need to be customized must be reentered.

5. Check for bad connections.
6. Check the display. If the CPU board is booting but you have no display, check the following:
 - Check the LCD backlight tube. Look very closely at the display to see if anything is visible in the dark screen. Using a beam type source of good lighting, such as a flashlight, look for any ghost type image. If it appears that there is something on the screen but very dark, the problem maybe with the LCD backlight tube. On the LG Philips, NEC and Sharp displays this tube is field replaceable. On the Samsung LCD display it is not available and the display will have to be replaced. There may be a sticker on the display mounting plate. If there is, it will have a part number that describes the type of display. If there is no sticker, you must take the display apart to identify the display manufacturer.
 - Verify that both the display cable and the inverter cable are firmly seated.
 - These cables both originate from the same connector on the Quantum™ LX. It may be necessary to remove the video cable from the back of the LCD display and reseal it to be sure it is connected properly.
 - NOTE: This is a small connector and caution should be observed so that it is not damaged due to excessive force.

Refer to the Display Assembly Component Replacement Guide at the end of this section, and check that the LCD, LCD cable, and software versions are matched correctly.

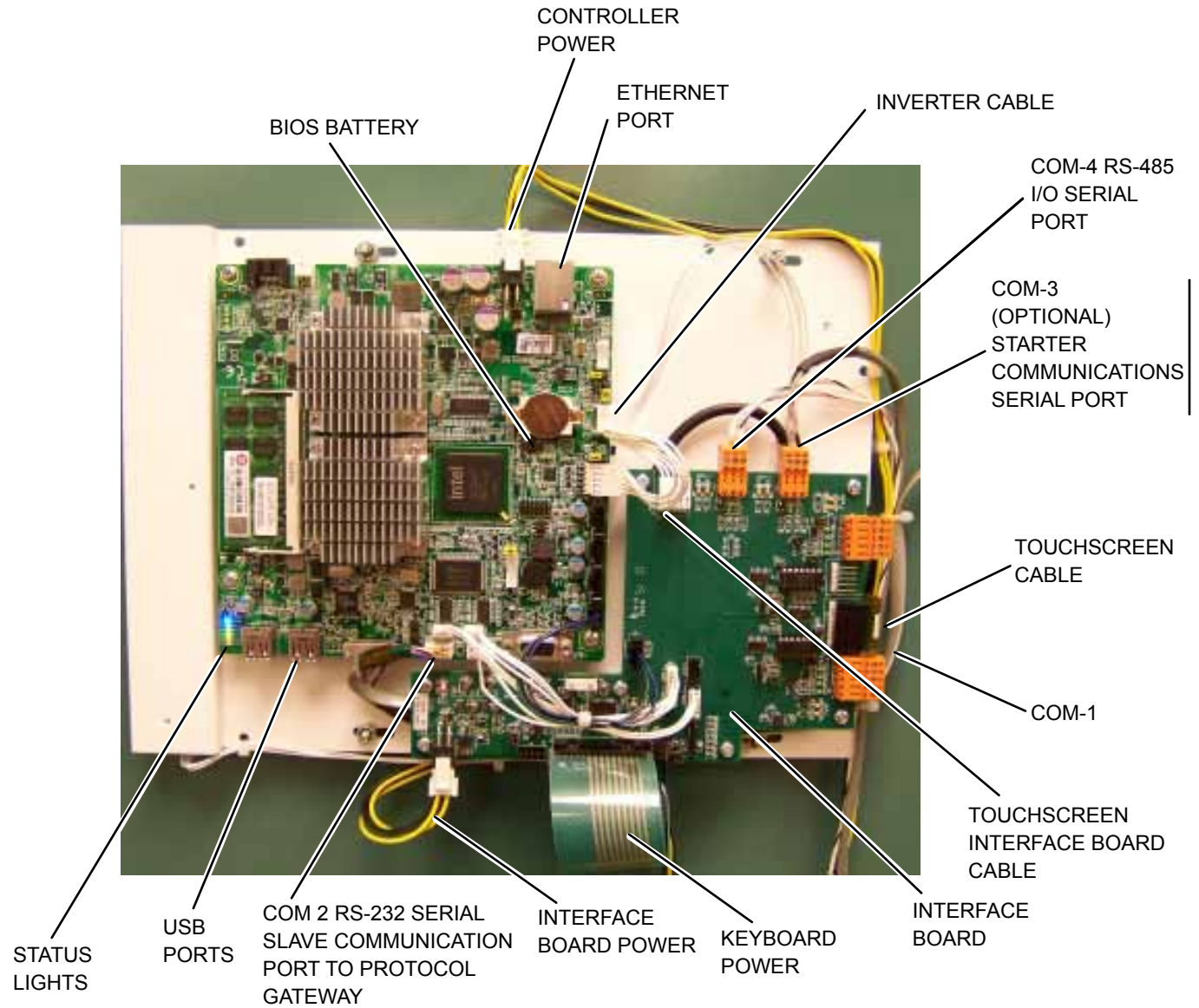

LD15224

FIGURE 1 - MAIN CONTROLLER BOARD AND PERIPHERALS

Set the Quantum™ LX 5 board jumpers as follows

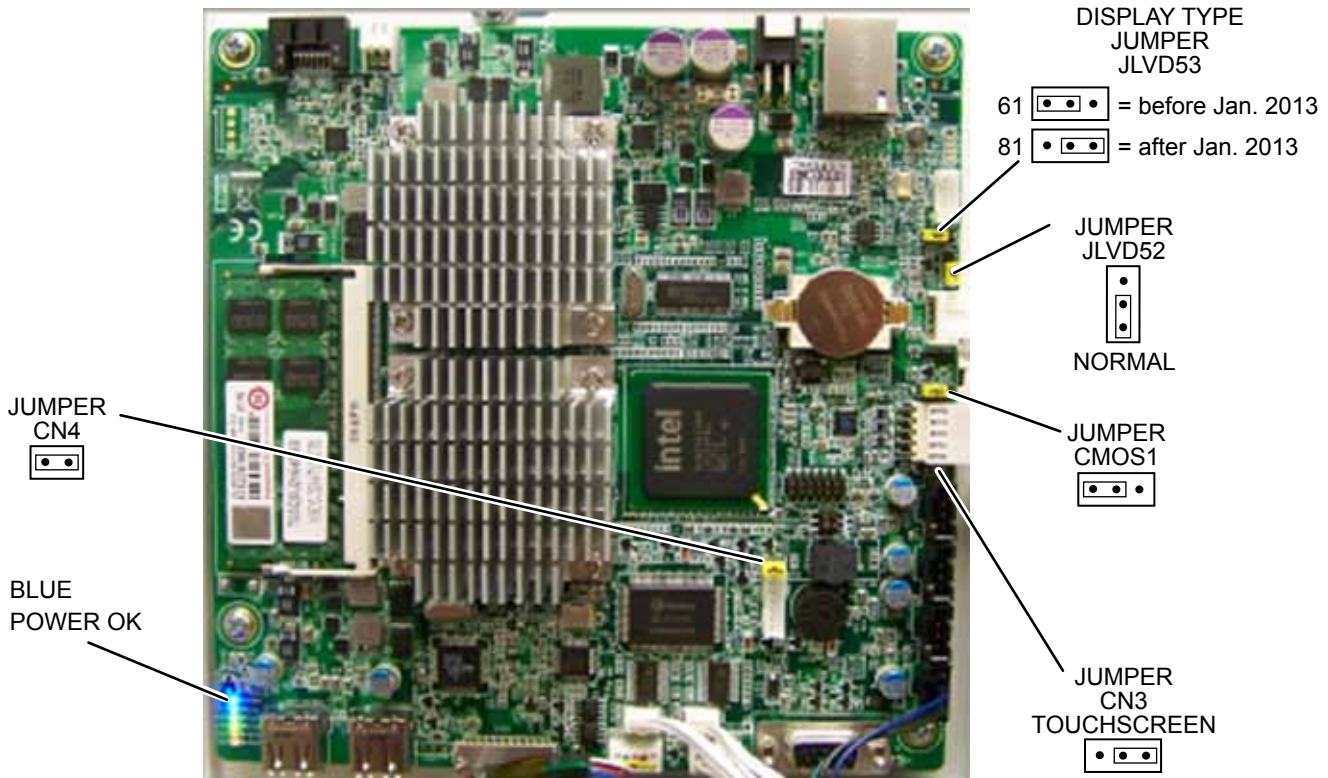

FIGURE 2 - QUANTUM™ LX JUMPER SETTINGS

LD15321

BATTERY FUNCTION AND REPLACEMENT

The Quantum™ LX board utilizes a battery to maintain correct date and time for the purpose of stamping warnings and shutdowns with the date and time that they occurred. If the date and time are not being maintained properly, this may indicate that the battery is not functioning, and should be replaced. The battery may be ordered through Baltimore Parts (P/N 333Q0001786) or may be purchased at most electronic shops (manufacturers P/N CR-2032).

The battery is fully assessable, but is surrounded by sensitive electronic components, so care should be taken when changing.

To replace the battery, ensure that the Control Power switch has been turned OFF.

Locate the Battery socket, as shown on the following drawing:

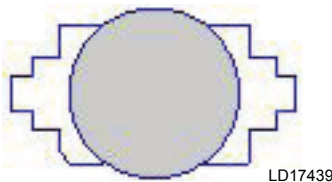

LD17439

Place your fingernail under the edge of the battery, and gently lift up. The battery should release itself from the socket easily. Take a new battery and place it into the holder in the same orientation as the old battery (the side with the writing must be facing out).

Return the Control Power switch back to ON. Once the Quantum™ LX has rebooted, the correct Date and Time must be set.

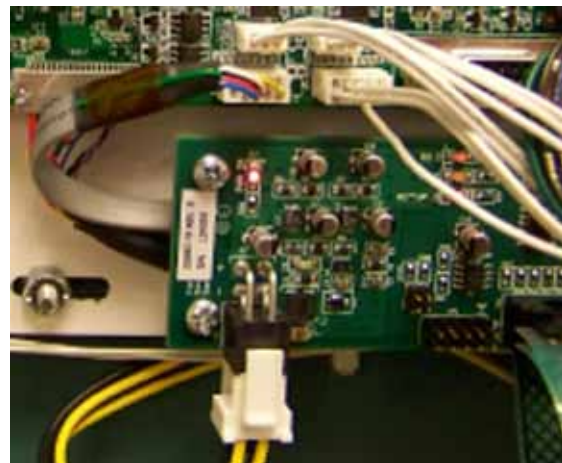

LD15322

FIGURE 3 - QUANTUM™ LX 5 MOTHERBOARD POWER CONNECTOR PINOUT

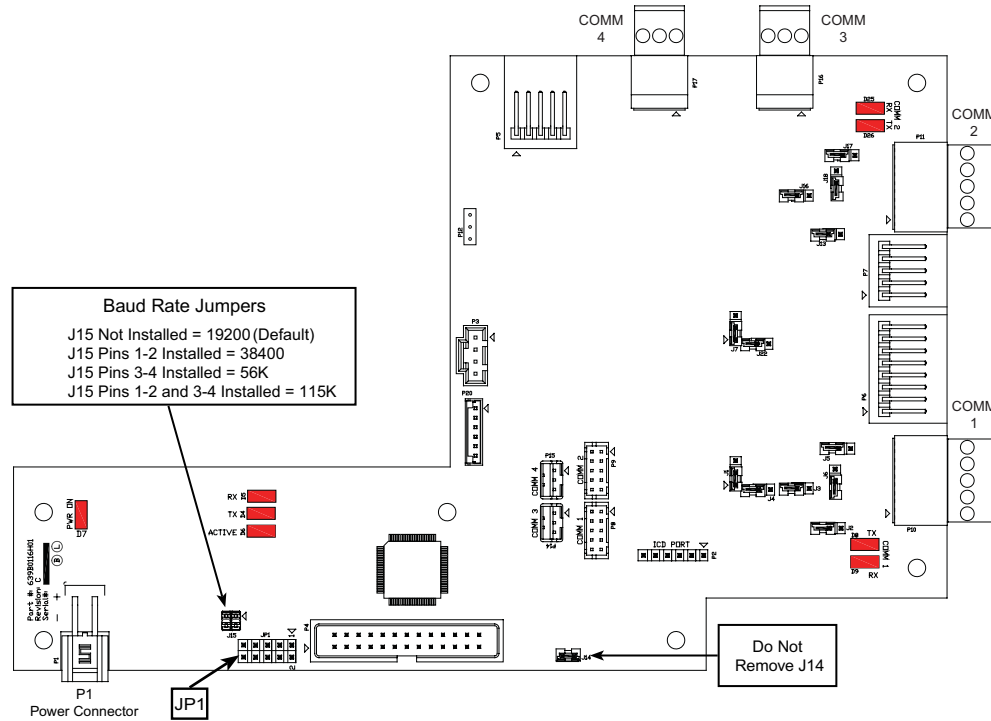

JP1 SYSTEM SETTINGS

Jumper JP1	Function	Jumper Setting	Jumper Setting
1 - 2	Not Used		Not Installed
3 - 4	Reformat E ² Prom		Installed
5 - 6	Erase Setpoints (at boot-up)		Installed
7 - 8	DG81 Display Installed (default)		Installed
	DG61 Display Installed		Not Installed
9 - 10	Disable Watchdog		Installed

NOTE: Jumper 7-8 is normally the only jumper that would be installed (for a DG81 display only)

COMMS 1 & 2 JUMPER SETTINGS
 (Comms 3 and 4 have no jumpers)

Comm 1	Comm 2	Function	Jumper Setting
J1	J7	RS-422 (4-Wire) Default	 1 - 2 Closed
		RS-485 (2-Wire)	 2 - 3 Closed
J2	J13	Pull Down Default	 1 Pin Only
J3	J16	Pull Up Default	 1 Pin Only
J5	J17	RS-422 Default	 1 Pin Only
		RS-485	 1 - 2 Closed
J6	J18	RS-422 Default	 1 Pin Only
		RS-485	 1 - 2 Closed
J4	J22	High Speed Target Default	 1 - 2 Closed

NOTE: The triangle symbol () denotes Pin 1 on connectors.

COMMS 1-4 PINOUTS AND JUMPER LOCATIONS

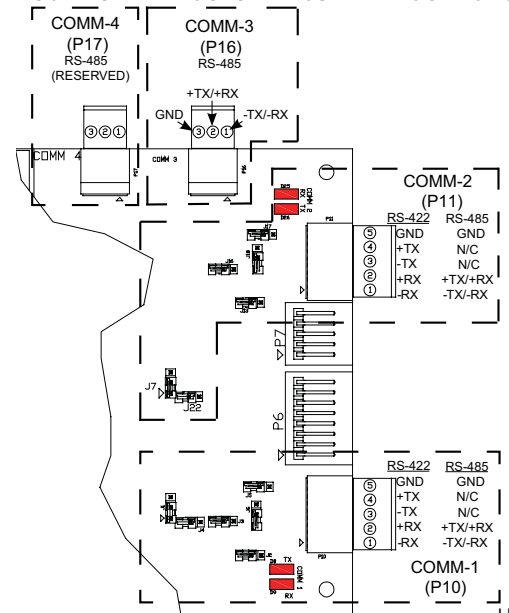

LD17440

FIGURE 4 - QUANTUM LX INTERFACE BOARD

QUANTUM™ LX INTERCONNECTIONS

The pictorial below depicts the Quantum™ LX motherboard, and the necessary interconnects between it and the Interface board. Each of the interconnecting harnesses must be installed as shown for proper operation.

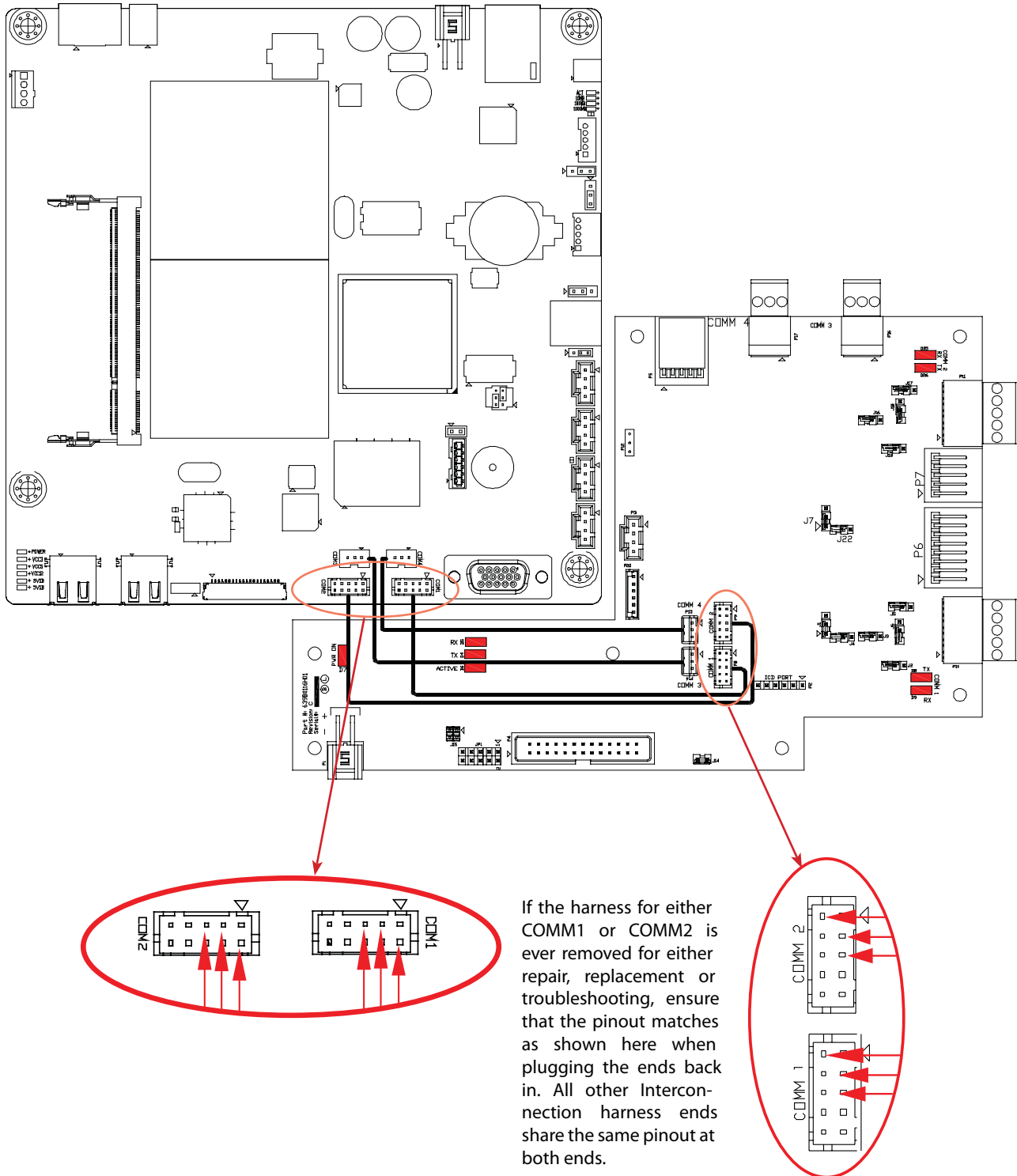

LD17441

FIGURE 5 - QUANTUM LX INTERCONNECTIONS

POWER SUPPLY (QUANTUM™ LX)

Description

The power supply of the Quantum™ LX control panel consists of three independent supplies, and are located on the inside of the front door below the Interface board. They supply the following DC voltages:

- +5 VDC
- +12 VDC
- +24 VDC

All three supplies are adjustable and each has an indicator to show that they are powered. Refer to the following page for the location for the adjustment.

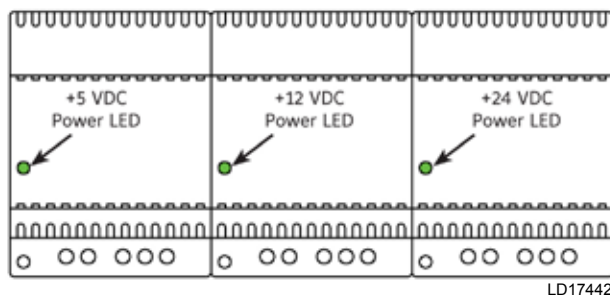

FIGURE 6 - POWER SUPPLIES

POWER DISTRIBUTION

DC power coming from the power supplies is wired directly to a series of terminal blocks. The terminals for these voltages are labeled as follows:

- Common (1000)
- +24 VDC (1004)
- +5 VDC (1001)
- +12 VDC (1002)

Power is then distributed to the Quantum™ LX processor board, Interface Board, and Digital/Analog I/O boards from these terminals.

MEASURING VOLTAGES

CAUTION! Measuring and adjusting the power supply voltages require the control power switch to be energized. Extreme care must be observed when taking any readings, as 120 or 230 VAC (depending on incoming system voltage) will be present next to the DC voltage connector. Adjusting the supplies requires the use of a small Philips screwdriver inserted into the supply to access an adjusting potentiometer.



It is possible for the screwdriver (and the person making the adjustment) to come into contact with potentially lethal voltages. Proper Personal Protective Equipment (PPE) measures need to be observed.

All circuit boards within the Quantum™ LX control panel require accurately adjusted DC voltages in order to function properly. Periodic measurement and adjustment of the DC power system is recommended for optimum system operation. Over time, it is possible for temperature, humidity, vibration and component age, to degrade the accuracy of these voltages. When any of the DC voltages begin to stray from their optimum range, mysterious problems can begin to arise. Even with a perfectly adjusted supply, it is possible for a potential drop in voltage at each connection point. This drop normally is in the millivolt range, but under some conditions, the drop can be much greater (as high as tenths of a volt). By the time the voltage reaches the last board in the daisy chain, and all of these potential voltage drops are considered, the combined drop can be such that problems can be apparent. Some examples of problems could be:

- Loss of or intermittent communications failures.
- A shutdown message stating Digital Board x Reset (where "x" is replaced by the number of the Digital Board that failed).
- An shutdown message stating Digital Board x Comm. Fail - Shutdown (where "x" is replaced by the number of the Digital Board that failed).
- An shutdown message stating Analog Board x Comm. Fail - Shutdown (where "x" is replaced by the number of the Analog Board that failed).
- Numerous sensor fault shutdown messages.
- Quantum™ LX reboots for no apparent reason.
- Improper readings of analog pressures and temperatures.
- LED's on the Quantum™ LX are lit, but nothing appears on the display.

To perform measurements and adjustments on the power supply voltages, use a reliable, calibrated Digital Volt Meter (DVM). The DVM should be accurate to 1/100 of a volt DC. With the control power switch turned ON, wait until the Operating Screen appears. This is because the graphics required to create this

screen will draw more current than when the screen is showing the normal POST (DOS) style messages during a boot up. If the screen never appears however (possibly due to a voltage problem), you will need to proceed regardless of what is or is not displayed.

In order to properly measure the DC power system, it must be checked at the DC power terminal strip.

ADJUSTMENT

Ensure that the meter is set to the proper range (DC, 0-50 V or equivalent), as well as observing proper wire polarity. The power supply drawing shown on the following page applies to all three power supplies. The adjustment access hole for each supply is located on the lower left of the front of the supplies. If an adjustment is required, use a thin, Philips screwdriver, insert the tip into the access hole for the appropriate voltage potentiometer (refer to the diagram on the following page for adjustment location).

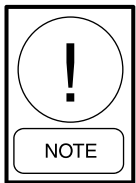

Extreme care must be used when adjusting the potentiometer. Adjustment should only be performed by qualified personnel. The use of a non-conductive device is recommended.

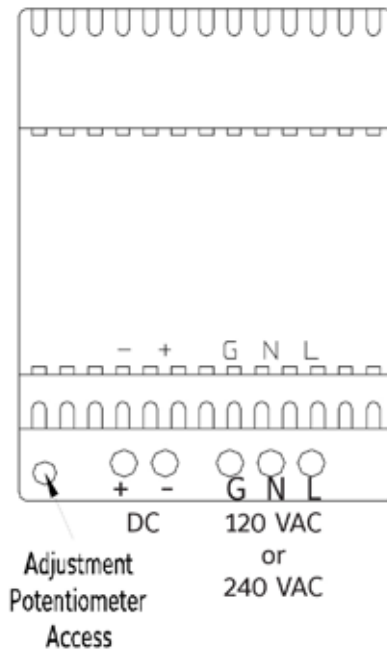

LD17443

FIGURE 7 - POTENTIOMETER ADJUSTMENT

+5 VDC Adjustment

Locate the DC power terminal strip. Terminal 1001 is the +5 VDC, and 1000 is common (COM). Place the negative lead on 1000, and the positive lead on 1001. Verify that the DVM is displaying in the range of +5.10 to +5.20.

If adjustment is required, locate the adjustment access hole on the +5 VDC supply, as previously shown. While watching the DVM, slowly rotate the screwdriver blade clockwise to increase the voltage or counter-clockwise to decrease until the voltage is correctly adjusted.

+12 VDC Adjustment

Locate the DC power terminal strip. Terminal 1002 is the +12 VDC, and 1000 is common (COM). Place the negative lead on 1000, and the positive lead on 1002. Verify that the DVM is displaying in the range of +12.10 to +12.20.

If adjustment is required, locate the adjustment access hole on the +12 VDC supply, as previously shown. While watching the DVM, slowly rotate the screwdriver blade clockwise to increase the voltage or counter-clockwise to decrease until the voltage is correctly adjusted.

+24 VDC Adjustment

Locate the DC power terminal strip. Terminal 1004 is the +24 VDC, and 1000 is common (COM). Place the negative lead on 1000, and the positive lead on 1004. Verify that the DVM is displaying in the range of +24.20 to +25.50.

If adjustment is required, locate the adjustment access hole on the +24 VDC supply, as previously shown. While watching the DVM, slowly rotate the screwdriver blade clockwise to increase the voltage or counter-clockwise to decrease until the voltage is correctly adjusted.

POWER SUPPLY REPLACEMENT

If any of the power supplies are found to be bad, or not capable of acceptable adjustment, the failing supply will need replacing. Refer to the Recommended Spare Parts list for the appropriate part number.

Digital Board

The information that follows in this section can help locate problems that may occur with Digital Input and Output circuit boards, and their interaction with the Quantum™ LX controller.

Digital Board Description

The Digital Board is actually a small microprocessor board and programmed to control discrete outputs, or accept discrete inputs, from external electrical devices. Each Digital Board has the capability of 24 independent channels or I/O (Input/Output). These I/O channels are dedicated as to their function, through the operating system (software), enabled options and external wiring. Each channel that is used by the software will have a module plugged into it. A yellow module indicates that it is used for Inputs. A black module is used for Outputs. A white module is for 24VDC inputs channels. The standard Quantum™ LX for CYK will have two Digital Boards.

Communications LED's

The Quantum™ LX controller is in constant communication with all Digital (and Analog) Boards. You will notice on each Digital and Analog board, that there are a pair of LED's labeled as RX and TX. These letters represent Receive (RX) and Transmit (TX). These LED's should be flashing at a high rate during normal operation. This indicates that the Quantum™ LX, and the Digital Board that you are looking at, are properly communicating with each other.

Reference the JUMPER AND DIPSWITCH SETTINGS section later in this manual. This section contains the dipswitch settings for addressing the Digital I/O Boards. When these switches are properly set, the Quantum™ LX is able to serially communicate with each I/O board and provide control signals and data exchange. If these switches are not properly set, the result will be lost or failed communications, the wrong outputs being energized, or the wrong inputs being received.

Connections to the Quantum™ LX

As stated earlier, the Quantum™ LX for CYK control system utilizes two Digital, and two Analog Boards. (A third Analog board is optional for motor temperature or vibration monitoring.) To connect all of these boards together so that the Quantum™ LX can control them, they must be interconnected with a wiring harness that provides all of the necessary D.C. voltage

requirements, as well as the communications capabilities. Two different harnesses have been used and a diagram of each of these wiring harnesses can be found later in this manual (see the Power I/O Wiring Harness drawings). Depending on the type of panel, the following harness will be used:

The wires that are inserted into the positions of one row are internally daisy chained on each I/O board, to continue the voltages and signals to the adjacent row. Therefore, any time that a connector is unplugged from the daisy chain, these voltages and signals cannot continue through the daisy chain to the next board. Whenever a plug is not to be inserted into a board, either for service or if not all boards are present, then a shunting plug (refer to Recommended Spare Parts list) must be installed onto the open connector. The four wires that feed from the power supply to the Quantum™ LX provide all of the necessary D.C. voltage that is required (+5 VDC, -12 VDC, +12 VDC, and Return or Common). The voltages are passed through the connector on the Quantum™ LX, and two new signals are generated by the Quantum™ LX to be passed on through the daisy chain to the I/O boards. These two signals are the RX (receive) and TX (transmit). These signals are the means by which the Quantum™ LX communicates to the I/O.

The Digital Boards only require the +5 VDC voltage and the Return (or common) for logic power. The communications signals (RX and TX) are required by all boards.

Logic Voltage (Power) LED

Located on the Digital Board is a Power LED. This LED will be illuminated as long as the Control Power switch is ON, and the proper voltage is present at the Quantum™ LX power supply. The power supply generates the +5 VDC voltage and passes it on through the Power-I/O harness. This LED does not indicate however that the proper voltage is necessarily present at the board, only that the voltage is enough to energize the voltage sensing circuitry. If a voltage related problem is suspected with regard to a Digital Board, the only way to actually determine this is to read the voltage on a Digital Voltage Meter (DVM). This may be accomplished by locating the white power / communications connector on the board. Notice that the Digital Board has one of these connectors on both ends of the board. The associated power/communications harness will only be plugged into one of these connectors. Take the red (positive) probe of the DVM and carefully insert

the end into the “+5V” lead, and the black (negative) probe end into the “RET” (Return or Common) lead, as shown in the previous section.

Set the DVM to read DC, and set the proper range. The voltage reading must read a minimum of +5.0 VDC. The Power-I/O harness will have an associated voltage drop at each board connection. As an example, if you are reading the voltage at the first I/O board in the daisy chain, and it reads 4.98 VDC, you can be assured that the voltage at the subsequent connections for the remaining boards will be lower yet. The voltage will need to be corrected for proper operation of the system. The cause for a low voltage reading could be:

- The Quantum™ LX power supply may need adjustment (see the section on power supplies).
- The Power-I/O communications harness has a problem (a new harness may be needed).
- A problem may exist with one of the I/O boards (Digital or Analog).
- If the power LED is not lighted, check the cable for proper connectivity. Note: Each board provides the necessary connections to feed all signals to the following connectors. If the auxiliary Analog board is not installed, then a jumper plug (see Renewal Parts List) must be installed to daisy chain the signals.

The most common problem that is due to a low +5 VDC voltage to the Digital Boards is an alarm message that reads Digital Board Reset Shutdown.

Active LED

The Digital Boards have an Active LED indicator on the board that blinks when the board’s software is running. The activity LED indicators are labeled TX and RX. If the Active LED’s are not blinking, check to ensure that the EPROM is installed properly. The EPROM is located in chip slot U8, next to the power connector.

Digital Inputs

A Digital Input is the portion of the hardware that allows devices such as limit switches, relay contacts, and level switches, to interface with the Quantum™ LX. The software program within the Quantum™ LX is constantly looking at these Input channels, via communications, and based upon whether a control voltage is present or not, will provide the necessary control for an associated Output channel. For instance, if a control voltage

is present on the Oil Level Sensor input, the software will determine that the Separator has sufficient oil level for the oil heaters to be energized (if the temperature of the oil is also sensed to be low. Temperature sensing will be discussed in the Analog Input section). There are two possible varieties of Digital Input modules used on Frick standard control packages, however the CYK system only uses 120 VAC modules. Both of these module styles for 240 VAC and 120 VAC are yellow in color. Be certain that you have the correct module for 120 VAC. A side profile of these modules is shown below:

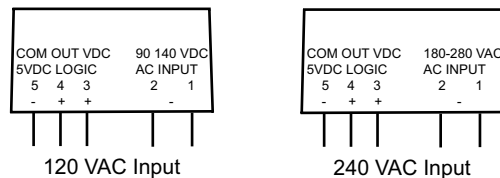

LD15226

FIGURE 8 - DIGITAL INPUT MODULES

These Input modules, can be identified as to their operating voltage by looking at either the side, as shown above, or from the top. You will notice the module operating voltage printed on the top, and the voltage range printed on the side.

Never plug a 120 Volt Input module into a 240 Volt system, and vice-versa. Never plug an Output module into a position designated for an Input module. You will notice that when a module is plugged into the Digital board, there is a fuse located directly adjacent to the module. This fuse is of the pluggable variety, and must be plugged into the IN position for an Input module.

Digital Outputs

A Digital Output is the portion of the hardware that the Quantum™ LX is to control (energize). These devices include solenoids, relay coils, and heaters to be energized, based upon the logic within the Quantum™ LX software program. There is one variety of Digital Output modules used on standard compressor control packages. This module is black in color. A side profile of this module is shown below: Although this Output module is labeled as 280 VAC on the top, and on the side, it can be used on both 120 and 240 volt applications. Never plug an Input module into a position designated for an Output module. You will notice that when a module is plugged into the Digital Board, there is a fuse located directly adjacent to the module. This fuse is of the pluggable variety, and must be plugged into the OUT position for an Output module.

Checking The Digital Inputs and Outputs

Some problems that may be encountered involve troubleshooting the digital inputs and outputs. The Digital I/O (Input / Output) Boards have six Digital I/O (DIO) board connectors labeled P1 through P6. The Input and Output modules are wired to a DIO connector plug. Position 3 provides power and position 4 is a neutral on the DIO connectors. Positions 1, 2, 5, and 6 are signal connections, as shown below:

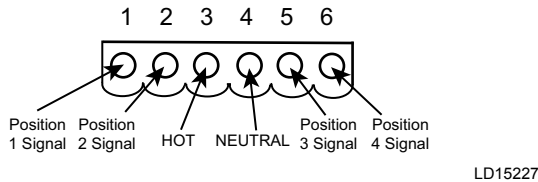

FIGURE 9 - DIO CONNECTOR PLUG

The Digital I/O board's I/O modules are configured by proper module selection, AC or DC, operating voltage, input or output, and moving the fuse to the in or out position. The CYK I/O boards will be configured properly, refer to the Renewal Parts manual for details. An LED is associated with each module and displays the state of each module. A lit LED represents an Input that is High, receiving a signal or an Output that is On. Each of the sixteen modules has a corresponding display value shown on the I/O diagnostics screen. If a properly configured Digital I/O is not responding correctly, first look at the Digital Board on the "Setup Screen >> Digital I/O" and check if the module is on. If it is not on, check if the LED on the Digital Board is also not lit. If the LED is not lit, then check the fuse. If the fuse is OK, then check the module.

Fuse Testing and Replacement

1. Power off the panel.
2. Open the panel door.
3. Remove the questionable fuse.
4. Place the questionable fuse into the fuse tester at the one end of each Digital I/O Board refer to the Digital Board drawings at the end of this section for exact fuse tester location).
5. Power on the panel.
6. Check the LED on the tester. If the LED is lit, the fuse is OK.
7. Power off the panel.

8. If the fuse is faulty, check for external shorts on the corresponding circuit, the replace the fuse with a new plug-type fuse (refer to Recommended Spare Parts list).

Input and Output Module Testing and Replacement

1. Power off the panel.
2. Open the panel door.
3. Replace the questionable module.
4. Power on the panel.
5. If it is an Output module, check for proper panel voltage on the DIO connector plug. Check the voltage between position 4 (neutral) and the associated position to the Output module.
6. If it is an Input module, check if the associated LED is on when power is applied to the module.

Troubleshooting an Output

1. Make sure the LED associated with the Output is on when power is applied to the module.
2. If the LED is on when it should be, check for proper panel voltage on the DIO connector plug. Check the voltage between the position 4 (neutral) and the associated position to the
3. Output module.
4. If the voltage is OK, check for proper panel voltage between the associated position to the
5. Output module on the DIO connector and the associated position on the terminal strip.
6. If the voltage is OK, check the wiring external to the panel.
7. If voltage is not OK, check the fuse.
8. If the fuse is OK then check the module.
9. If the module is OK, check for proper panel voltage on the DIO connector plug between position 3 (Hot) and position 4 (neutral).
10. If the LED is not on when it should be and there is no operating condition preventing it, contact the Service Department.

Troubleshooting an Input

1. Make sure the LED associated with the Input is on when power is applied to the module.
2. If the LED is on then the fuse and Input module are good.
3. If the LED is on and there is no input voltage, replace the Input module.
4. If the LED is not on when power is applied, check the fuse.
5. If the fuse is good, replace the Input module.
6. If you are receiving an Alarm or Shutdown from a digital input in which the adjacent LED indicator light is on, check the Service Screen to see if that channel is turning on and off. If so, replace the input module.

Replacing a Defective Digital Board

The procedure to replace a Digital board is outlined below:

1. Shut off control power.
2. Remove the old board from the machine and the new board from its packing and place both on an anti-static surface.
3. Check that all jumpers, dipswitches and components are properly setup on the new board as it was on the old board (refer to the Digital Settings tables near the end of this section).
4. Install the modified replacement board in the panel.

DIGITAL BOARD #1
INSTALL FUSES AND MODULES AS SHOWN
 Black = Output, Yellow=Input 120v, White=Input 24VDC

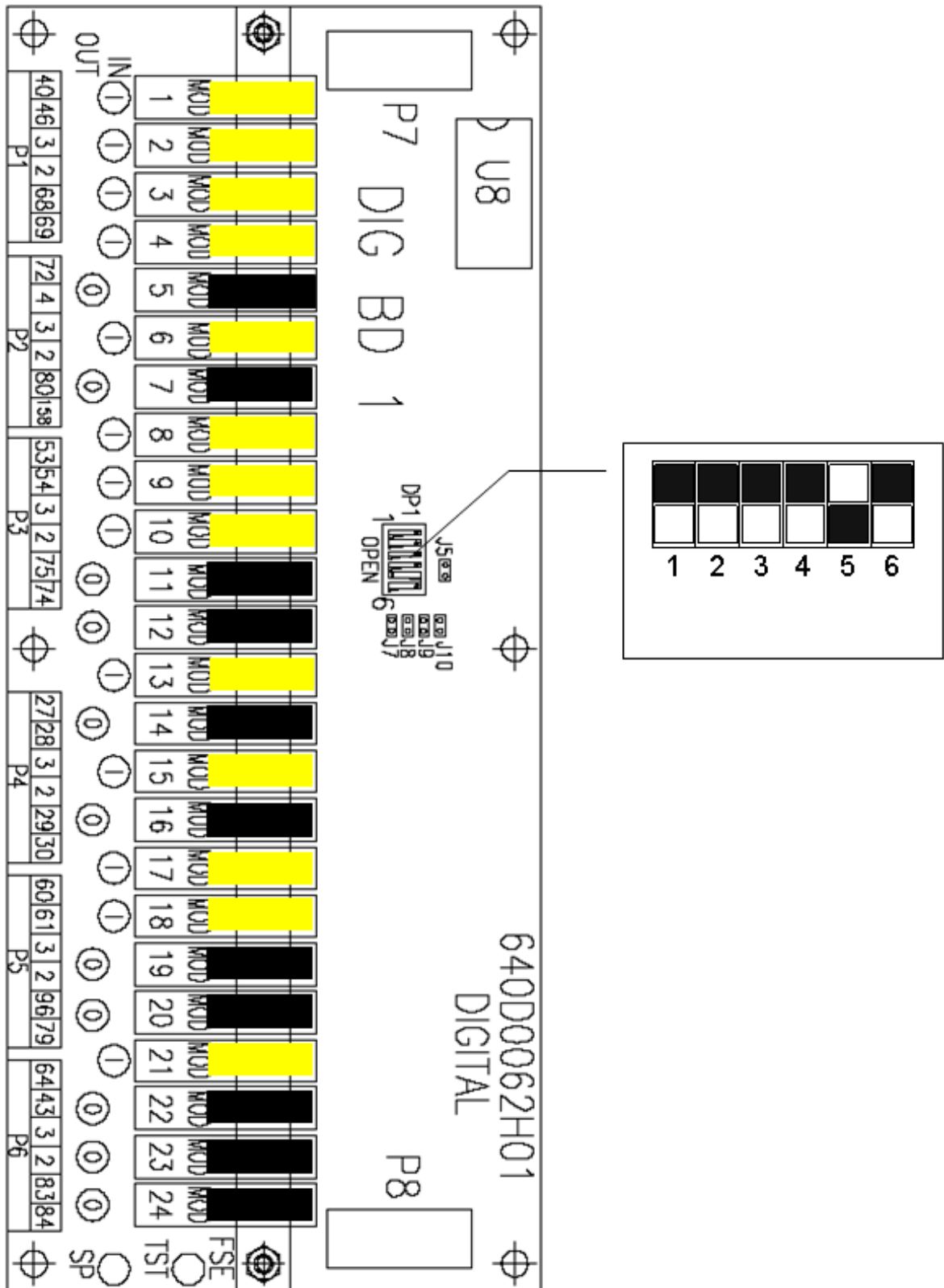
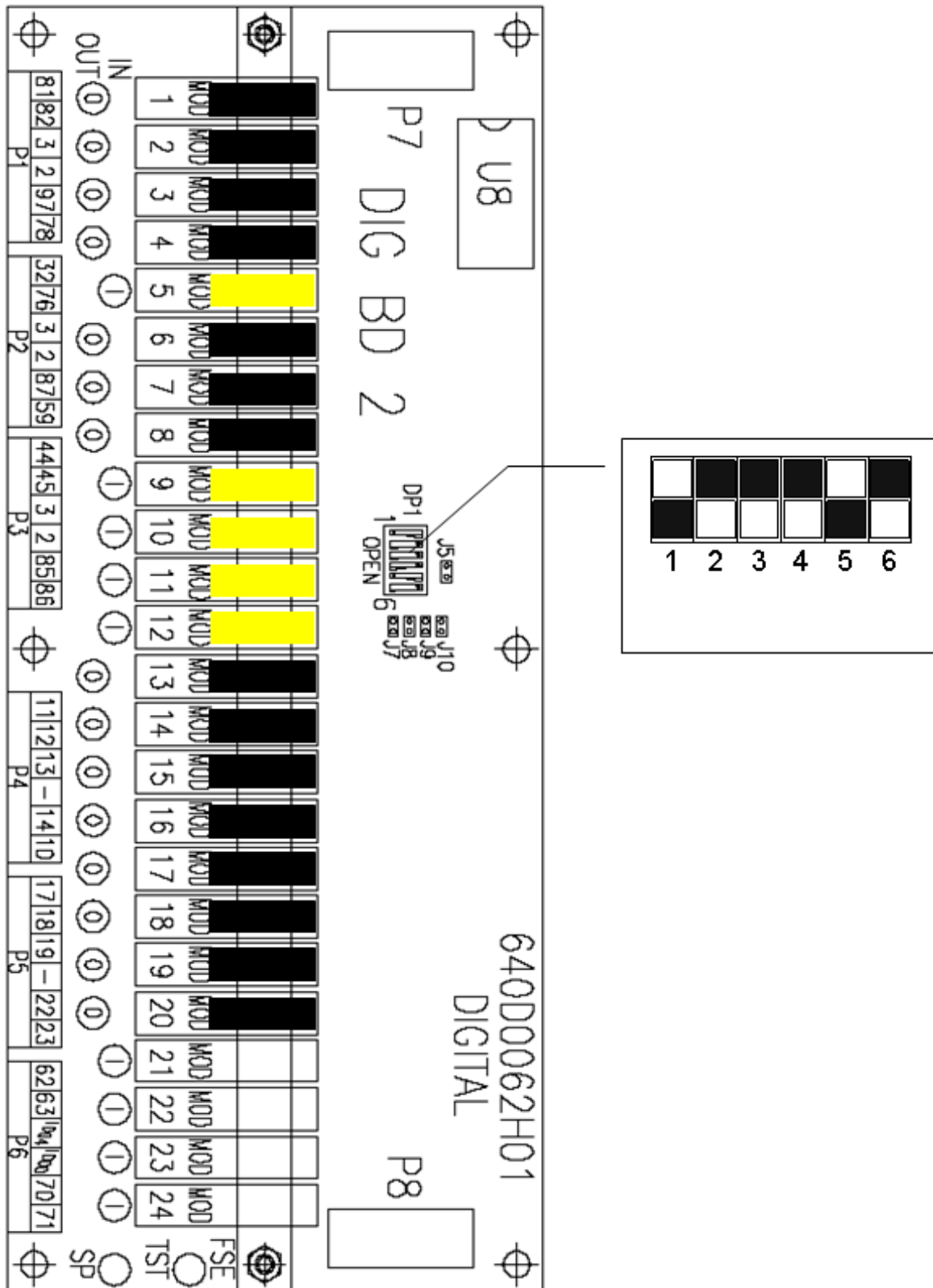

FIGURE 10 - DIGITAL BOARD #1

LD15299

DIGITAL BOARD #2
INSTALL FUSES AND MODULES AS SHOWN
Black = Output, Yellow=Input 120v, White=Input 24VDC



LD15300

FIGURE 11 - DIGITAL BOARD #2

Analog Board

Overview

The Frick Quantum™ LX control panel is capable of reading external analog devices, such as temperature probes and pressure sensors. It uses these input signals for the purpose of monitoring and control. As an example, if an external temperature sensor began to read a higher than expected temperature in some area, the controller would sense this change, and provide the necessary output control signal to remedy the situation. Unlike a digital signal, which is typically either an on or off state, an analog signal can assume a wide variety of states, such as a temperatures probe reading a wide range of temperatures. The method used for receiving (and sending) these signals, is the analog board. The analog devices are wired directly to the board, and the on-board software/hardware converts the electrical signals received from these devices into data, which is then sent on to the Quantum™ LX control board via communications, and is monitored by the Operating system.

Analog Board Description (32 Channel)

The Analog Board is actually a small microprocessor board and is programmed to control analog outputs, or accept analog inputs, from external electrical devices. Each enhanced board has the capability of 24 independent input channels. With the Quantum™ LX CYK Control panel, these I/O channels are dedicated through the software and external wiring, as to the function of each channel. The Quantum™ LX controller can utilize up to three separate analog boards (Analog board #1, #2, and optionally #3), depending on the selected options.

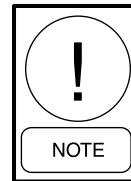

The CYK application requires a specific level of firmware in the Analog I/O board. Only use the approved part number for Analog Board #2, which controls the PWM output control of the VS Oil Pump Drives. Only replace an Analog Board #2 that has a Firmware Version 2.52 or higher, refer to the Renewal Parts manual.

DIGITAL BOARD SETTINGS

TABLE 1 - COMMUNICATIONS SETTINGS

The following table is to be used when configuring the Quantum™ LX for external communications.

J5	in	120 ohm long communications line termination.
	out*	No termination.
J7	in	RS-422/485 transmit pull-up for long communications lines.
	out*	No pull-up.
J8	in	RS-422 transmit pull-up for long communications lines.
	out*	No pull-up.
J9	in	RS-422/485 receive pull-down for long communications lines.
	out*	No pull-down.
J10	in	RS-422 receive pull-down for long communications lines.
	out*	No pull-down.

* standard setting

TABLE 2 - DIPSWITCH SETTINGS

The following table is to be used to set the digital board addresses. If there is only one board installed, it should be set as board #1, if there are two boards they each need to be set according to the wiring diagrams.

	SW1	SW2	SW3	SW4	SW5	SW6
Board #1	on	on	on	on	off	on
Board #2	off	on	on	on	off	on

Communications LED's

The Quantum™ LX controller is in constant communication with the Analog (and Digital) Board(s). You will notice on each Analog and Digital board, that there is a pair of LED's that are labeled as RX and TX. These letters represent receive (RX) and Transmit (TX). These LED's should be flashing at a high rate during normal operation. This indicates that the Quantum™ LX, and the board that you are looking at, are properly communicating with each other.

Refer to the Analog I/O board setup later in this section. This section contains the dipswitch settings for addressing the Analog I/O Boards. When these switches are properly set, the Quantum™ LX is able to serially communicate with each I/O board and provide control signals and data exchange. If these switches are not properly set, the result can be one of the following:

- Lost or failed communications (displayed in the Communications Status box on the Home screen)
- The wrong analog input signals being received
- The wrong analog output signals being sent from the board.

Connections to the Quantum™ LX

A copy of the chiller elementary wiring schematic is shipped with the CYK in a document pocket in the control panel (see the Chiller Elementary Schematic drawing). This harness has a 6-pin connector at one end that plugs into the Quantum™ LX. Another connector plugs into the power supply. The remaining four connectors (16 pin) will plug into each of the Digital and Analog Boards in the system (up to four total).

Upon close examination of this harness, you will notice that each of the connectors for both the Quantum™ LX and the four I/O boards, have two rows of connections. The wires that are inserted into the positions of one row are internally daisy chained on each I/O board, to continue the voltages and signals to the adjacent row. Therefore, any time that a connector is unplugged from the daisy chain, these voltages and signals cannot continue through to the next board. Whenever a plug is not to be inserted onto a board, either for servicing, or if not all boards are present because of the options that are present, then a shunting plug (refer to the Recommended Spare Parts list) must be installed onto the open connector. The four wires that feed from the power supply to the Quantum™ LX provide all of the necessary D.C. voltage that is required (+5 VDC, -12 VDC, +12 VDC, and Return or Common). The voltages are passed through the con-

ductor on the Quantum™ LX, and two new signals are generated by the Quantum™ LX to be passed on through the daisy chain to the I/O boards. These two signals are the RX (receive) and TX (transmit). These signals are the means by which the Quantum™ LX communicates to the I/O. The Analog Board requires the +5 VDC for logic, the -12 VDC for internal voltage reference, and +12 VDC for external sensors (plus or +) and the Return (common or -). The communications signals (RX and TX) are required by all boards.

Logic Voltage (Power) LEDs

Located on the enhanced Analog Board are two power LEDs. The first of these is D1 LED (+5VDC), and will be illuminated as long as the Control Power switch is ON, and the proper voltage is present at Analog Board connector P3. The power supply generates the +5 VDC voltage, and passes it on through the Power-I/O harness. This LED does not indicate however that the proper voltage is necessarily present at the board, only that the voltage is enough to energize the voltage sensing circuitry. If a voltage related problem is suspected with regard to an Analog Board, the best way to actually determine this is to read the voltage on a DVM (Digital Volt Meter). This may be accomplished by locating the white power / communications connector on the board. Notice that the Analog Board has only one of these connectors. The associated power/communications harness plugs in to it. Take the red (positive) probe of the DVM and carefully insert the end into the +5V lead, and the black (negative) probe end into the RET (Return or Common) lead, as shown below:

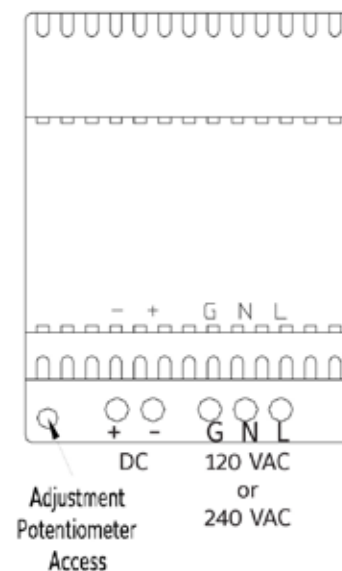

LD17443

FIGURE 12 - POTENTIOMETER ADJUSTMENT

Set the DVM to read DC, and set the proper range. The voltage reading must read a minimum of +4.98 VDC. The Power-I/O harness will have an associated voltage drop at each board connection. As an example, if you are reading the voltage at the first I/O board in the daisy chain, and it reads 4.98 VDC, you can be assured that the voltage at the subsequent connections for the remaining boards will be lower yet. The voltage will need to be corrected for proper operation of the system.

The cause for a low voltage reading could be:

- The Quantum™ LX power supply may need adjustment (see the section on power supplies).
- The Power-I/O communications harness has a problem (a new harness may be needed).
- A problem may exist with one of the I/O boards (Digital or Analog). If the power LED is not light-

ed, check the cable for proper connectivity. Note: Each board provides the necessary connections to feed all signals to the following connectors as in a “daisy-chain” network.

Active LED

The Analog Boards have an Active LED indicator that blinks when the board’s software is running. If the Active LED is not blinking, it could be an indication that the internal program is not running. Try powering the Quantum™ LX controller off, then back on to see if the Active light starts blinking. If not, a new board may be required.

Analog Inputs

An Analog Input is the portion of the hardware that allows devices such as temperature sensors and pressure transducers to interface with the Quantum™ LX.

TABLE 3 - ENHANCED ANALOG BOARD INPUT CONFIGURATION TABLE

CHANNEL	ICTD	0-5VDC	0-10VDC	0-20MA	POT (POTENTIOMETER)	CT (MOTOR CURRENT)	ACCELEROMETER (VIBRATION MONITORING)	RTD (MOTOR PROTECTION ONLY)
1	*	*	*	*				*
2	*	*	*	*				*
3	*	*	*	*				*
4	*	*	*	*				*
5	*	*	*	*				*
6	*	*	*	*				*
7	*	*	*	*				*
8	*	*	*	*				*
9	*	*	*	*				*
10	*	*	*	*				*
11	*	*	*	*				*
12	*	*	*	*				*
13	*	*	*	*				*
14	*	*	*	*	*			
15	*	*	*	*	*			
16		*	*	*		*		
17	*	*	*	*			*	*
18	*	*	*	*			*	*
19	*	*	*	*			*	*
20	*	*	*	*			*	*
21	*	*	*	*			*	*
22	*	*	*	*			*	*
23	*	*	*	*			*	*
24	*	*	*	*			*	*

NOTE: Enhanced Analog Board 2 can utilize channels 17 through 24 for PhD if Analog Board 1 is of the old style. Refer to the section on Software Configuration for specific information on the procedure to set these channels.

The software program within the Quantum™ LX is constantly looking at these Input channels, via communications, and based upon what the voltage or current level of the channel is, will provide the necessary control for an associated action. (Digital Inputs are discussed in the Digital Input section).

Analog inputs arrive at the board on connectors P4 through P10. Each of these connectors can receive two channels (for a total of twenty-four). Each of the twenty-four analog input channels is board software configurable to select for the following type of input signals:

Analog Outputs

An Analog Output is the portion of the hardware that the Quantum™ LX uses to provide control. With the Quantum™ LX, this output is dedicated for a 4-20 mA signal that is outputted to an external device, and cannot be changed through the software configuration.

Troubleshooting the Analog Inputs and Outputs

Some problems that are encountered involve troubleshooting the Analog inputs and outputs. The Analog Board has twelve Analog I/O board connectors labeled P4 through P10. The external Analog devices are wired to a connector plug. Position 1 connects to the plus (+) of the external device for channel 1, position 2 connects to the signal (SIG) of the external device for channel 1 and position 3 connects to ground (GND) of the external device for channel 1. Position 4 connects to the plus (+) of the external device for channel 2, position 5 connects to the signal (SIG) of the external device for channel 2 and position 6 connects to ground (GND) of the external device for channel 2, as shown below:

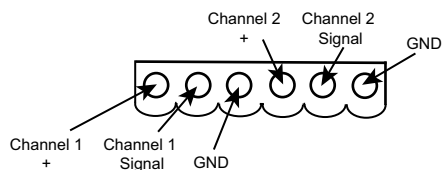

LD15229

FIGURE 13 - ANALOG OUTPUTS

Each input channel is configurable through the operating software. There are twenty-four analog input channels that can be selected for 4-20 mA, 0-5 VDC, 0-10 VDC, 0.5-4.5 VDC Ratiometric, ICTD, or RTD. Channel #16 will also take the 0-1 Amp motor CT as an input. Besides properly setting the software configuration, each channel is setup through software calibration for the proper transducer type and range, and each transducer must be calibrated through the appropriate

sensor calibration screen. These settings are all pre-programmed at the factory for the CYK Quantum™ LX control center. Improper setup of either the hardware or software will result in improper operation or range. The most common fault associated with the improper reading of the analog channels other than hardware or software setup problems fall into one of the following categories:

- Sensor fault
- Wiring problem
- Improper grounding of system.

An open wire, shorted wire, or faulty sensor will usually give a reading at either the minimum or maximum end of the range scale. An erratic reading or a reading that seems to float up and down is usually indicative of a grounding problem. When a single transducer or cable is shorted to earth (or system) ground, this can show up as a whole assortment of problem channels. The easiest way to find a short to earth problem is to disconnect all the sensor plugs and ohm out each plug screw terminal to earth for open (infinite) impedance. All sensors should read open to earth with the exception of the CT motor current channel. One side of the CT is grounded in the Motor Terminal Box. (The third pin on pressure sensors is ground.)

Replacing a Defective Analog Board

The procedure to replace an Analog board is outlined below:

1. Shut off control power.
2. Unplug all connectors from the board. Remove the old board from the machine and remove the new board from its packing and place both on an anti-static surface.
3. Check that all jumpers and dipswitches are properly setup on the new board as it was on the old board.
4. Install the modified replacement board in the panel.
5. Plug all connectors back in.
6. Turn on control power.
7. After replacing or installing an Analog Board and powering on the control panel, select **[Redetect I/O Comms]** from the **Home >> Setup >> Serial Port Setup** screen (from Service User level 2). This selection provides a method to detect all connected Analog and Digital boards. If a board has

been removed, a communication error shutdown will be issued until this key is selected. The History screen will show what was detected. The **[Redetect I/O Comms]** key resets the memory of the processor as to which boards it requires communications from. Therefore, it is important to check the History screen to see which boards have been detected relative to the I/O boards actually in the panel.

Current Transformer (Motor Amps)

Channel 16 of Enhanced Analog Board 1 is dedicated to reading motor amps, either through the use of the on board current transformer when using a 0-1 amp CT,

or from an external source. When reading motor amps directly at the P8 terminal strip from a CT, the input signal cannot exceed 5 amps. TR1 and TR2 timers in the control panel will provide a short around the motor current detection circuitry to avoid any currents over 5 amps from reaching the detection circuitry during Locked Rotor Amp inrush. If you are using an external direct current mA or voltage device, remove the jumper at Link 2, and connect the wiring to connector P7B. If you intend on utilizing the on-board current transformer, then install Link 2, and connect the wiring to Channel 16, as shown in the diagram below:

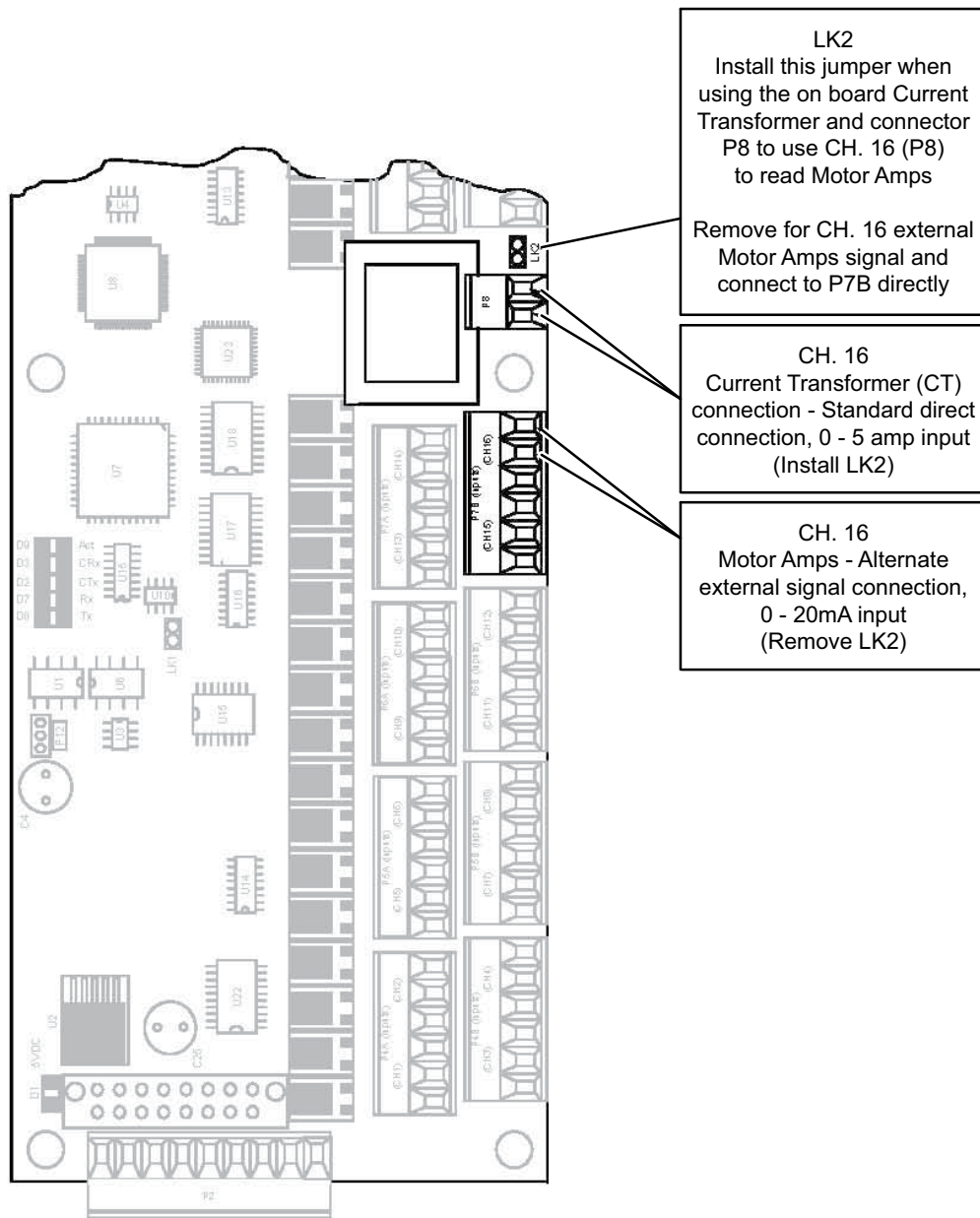

LD15286

FIGURE 14 - MOTOR AMPS

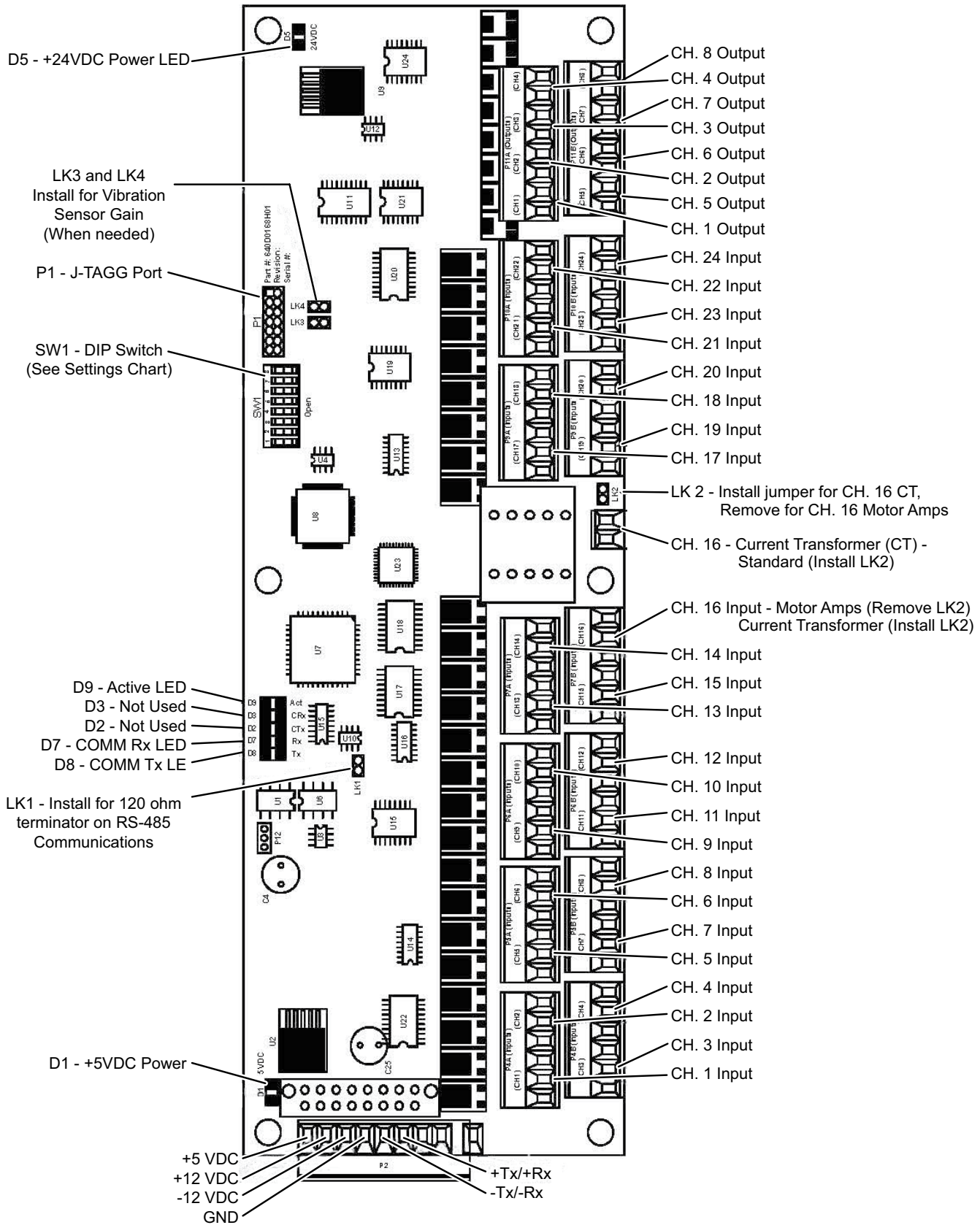

FIGURE 15 - ENHANCED ANALOG BOARD DIAGRAM

LD15287

ENHANCED ANALOG BOARD SETTINGS

TABLE 4 - COMMUNICATIONS

The following table is to be used when configuring the Quantum™ LX for external communications.

LK1	In	120 ohm long communications line termination.
	Out*	No termination.

* default setting

TABLE 5 - CURRENT TRANSFORMER (CT)

ANALOG BOARD #1			ANALOG BOARD #2		
LK2	In*	Install for CT (Current Transformer).	LK2	In*	(Must be removed)
	Out	Remove to read Motor Amps on P8.		Out	Remove (Not Used)

* default setting

TABLE 6 - DIPSWITCH SETTINGS (USED TO SET THE BOARD ADDRESS)

The following table is to be used to set the analog board addresses. If there is only one board installed, it should be set as board #1, if there are two boards they each need to be set according to the wiring diagrams.

	SW1	SW2	SW3	SW4	SW5	SW6	SW7	SW8
Board #1	off	off	off	off	off	off	off	off
Board #2	on	off	off	off	off	off	off	off

TABLE 7 - ANALOG BOARD

DESCRIPTION	ENHANCED ANALOG BOARD
Input Channels	24
Output Channels	8 (no driver chips required)
On Board CT (Current Transformer)	Yes (transformer incorporated on board)
On Board Vibration Circuit	Yes (no external modules required)
Channel Configuration	Software
Dimensions	4" x 11" (fits original board footprint)
Types of inputs:	
4 - 20mA	Yes
0 - 5 volt	Yes
1 - 5 volt	Yes
ICTD	Yes
RTD (1000 platinum)	Yes (currently for motor RTD inputs only)
Support Quantum™ LX Software Version	Resides in Flash Memory (Version 5.xx)
Service Dates	June 2003 - Present

REPLACEMENT PART NUMBERS	ANALOG BOARD 1	ANALOG BOARD 2	ANALOG BOARD 1	ANALOG BOARD 2
Baltimore Parts Replacement	640C0026G01	640C0026G02	640C0057G01	640C0057G02
Field Installation Kit	N/A	640C0057G11	N/A	640C0057G12

THIS PAGE INTENTIONALLY LEFT BLANK

SECTION 2 - FUNDAMENTALS OF OPERATION



FIGURE 16 - QUANTUM™ LX KEYPAD

OPERATOR INTERFACE

Description

The Quantum™ LX Operator Interface actually consists of two components: A color 10-1/2" (diagonally measured) graphic display, and a membrane touch keypad. The display is used to view information coming from the Quantum™ LX controller, while the keypad and touch display allows the user to enter information into the controller.

Display Assembly

The Display assembly consists of a 640 x 480 resolution, LCD screen (which includes a fluorescent backlight tube, a backlight inverter circuit board, a wiring harness, and a touch sensitive layer. Refer to the Renewal Parts List manual for specific replacement part numbers.

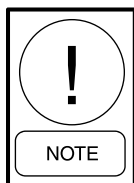

Before replacing a display unit, ensure that the symptom is not actually being caused by a bad fluorescent tube, inverter or harness.

Display Replacement

1. Shut off control power.
2. Remove the defective display.
3. Install the new display.

Keypad

The Keypad consists of two areas, the Display window and the Keypad itself. The Display window is simply a clear portion of the Keypad assembly which the Display is able to be viewed through. The Keypad area consists of a series of 27 membrane switches. Depressing each switch (key) should result in an audible tactile clicking sound. To ensure that each key is actually functioning, visually inspect the D8 LED located on the keypad interface board control board. This LED will normally flash on and off at a rate of about once per second. Pressing a key on the keypad will interrupt this flash rate, and repeatedly depressing a key will cause the LED to flash each time a key is pressed.

Keypad Replacement

1. Shut off control power.
2. Unplug the defective keypad from the Quantum™ LX.
3. The keypad is affixed to the controller door with a double-sided tape film. Start by lifting the key-

- pad at one of the corners. Once the keypad starts to break free from the underlying tape, continue pulling. A carefully used putty knife can help to separate the keypad from the adhesive.
- Once the keypad has been entirely removed, you will notice that much of the double-backed tape is remaining on the panel door. Carefully using a window scraper style razor will remove most of this tape. Be careful not to scratch the paint outside of the keypad footprint.
 - Take the new keypad, and feed the flat cable through the slotted opening at the bottom of the display area.
 - Remove the paper backing of the keypad to expose the double-backed tape underneath.

- Carefully align the keypad on the door, ensuring that the display is centered within the window of the keypad. Once you are satisfied with the position, firmly press the keypad into place.
- Plug the keypad cable back into the Quantum™ LX.
- Turn Control power back on.
- Test the new keypad as described earlier.

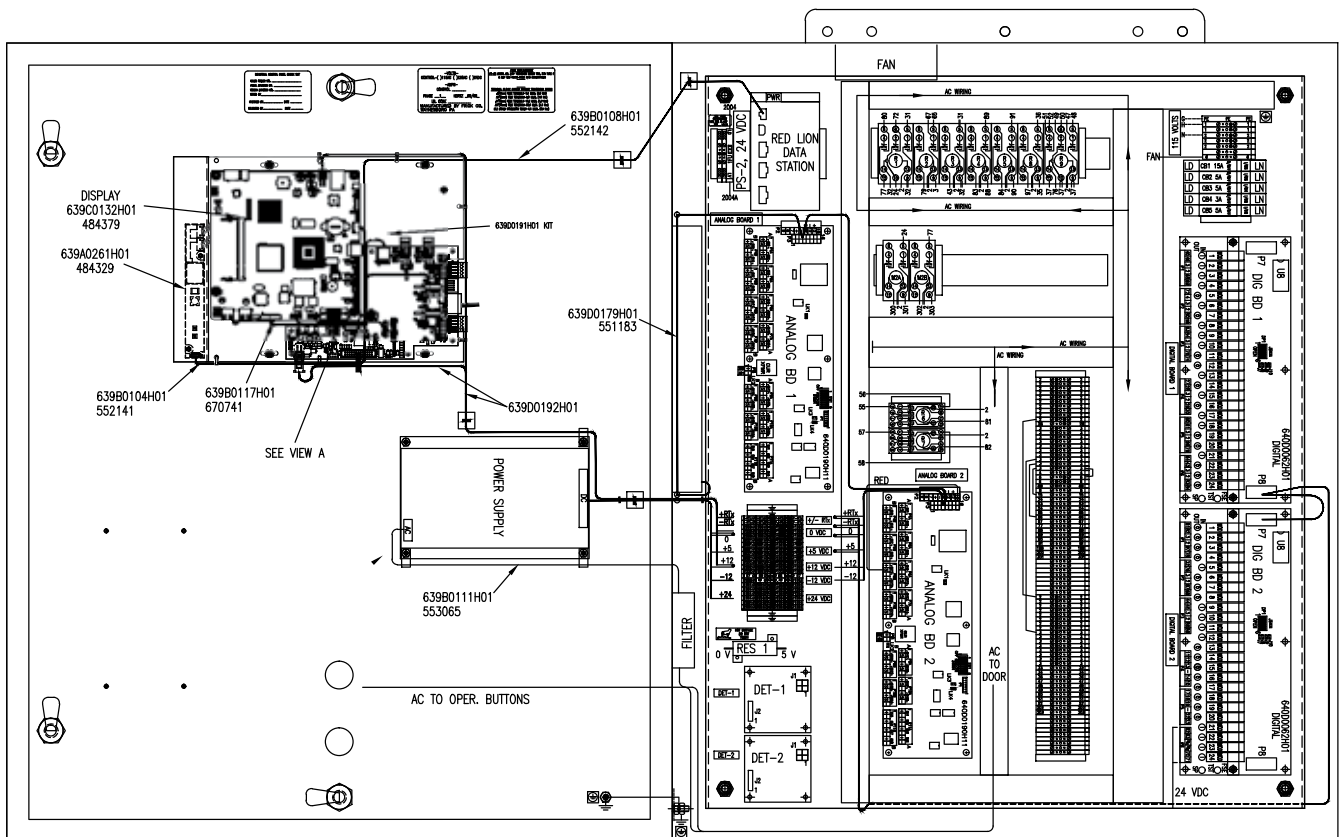

LD15289

FIGURE 17 - QUANTUM™ LX BASIC PANEL LAYOUT

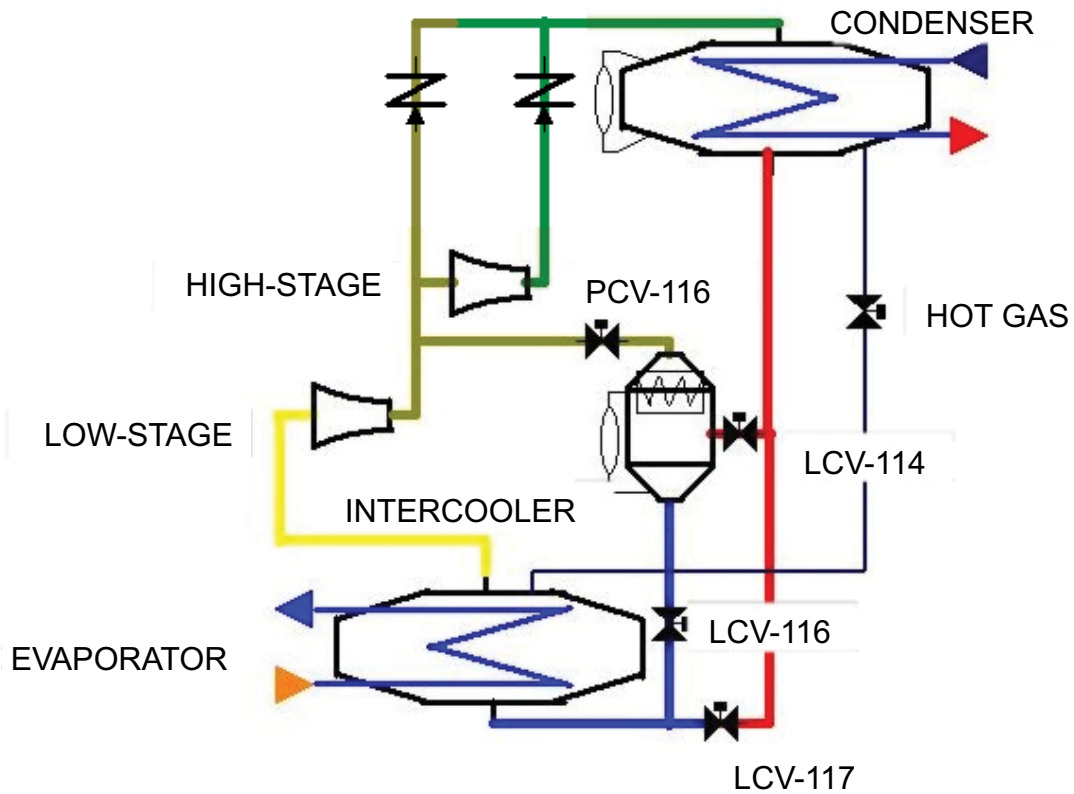

LD15238

FIGURE 18 - GENERAL OPERATING SEQUENCE

Unit Not Operating

1. Control power is available to the control panel.
2. Compressor sump oil heaters are thermostatically controlled 53°F above saturation.



Only apply auxiliary control voltage to the chiller when the oil sumps have been filled with oil. Uncovered oil heater assemblies will produce high temperatures and destroy chiller oil sump components.

3. The capacity controls are disabled.
 - The compressor pre-rotation vanes are closed.
 - The hot gas bypass is closed when the evaporator pressure is below a freezing potential / open above freezing
 - The subcooler valve is closed above freezing potential, open below freezing potential.
 - The economizer valve is partially open.
 - The economizer bypass valve is partially open.

- The Variable Geometry Diffuser(s) are set to the “StartCV” command position.
- Oil Heaters are controlling the oil temperature to maintain 53°F above saturation.

System Startup

1. All chiller safety logic must be satisfied prior to starting, with the exception of the compressor oil pressure. The oil pressure safeties are bypassed initially, until the main oil pumps can establish pressures. The flow safeties are bypassed until the water pumps can establish flows. 5 seconds before the Pre-lubrication cycle completes the flows must be established, or the unit will trip on loss of water flow.

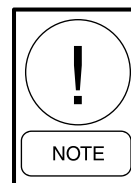

The hardwired safety relay MUST be clear of previous safety trips or power failures. The R1 hardwired safety relay must be physically reset. The R1 relay is hardwired in series with the high-pressure cutout and the emergency stop to shut down the main motors in the most extreme danger.



During the commissioning procedures, the Emergency Stop button should be pressed in, and R1 relay should be removed to prevent any undesired and inadvertent operation of the main motor starters. The Emergency Stop button is the “twist to reset” type.

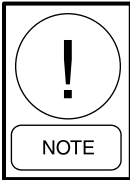

The System Status indicator box in the upper left corner of the DISPLAY screen will display the GREEN text “READY TO START.” This display will change at various times during the start-up and shutdown of the chiller.

See Graphic Displays for further details on the operator interface.

If the chiller has been recently started and shut down, the motor must remain off for sufficient time to cool down. See “Anti-recycle operation” at the further details.

- The chiller start may be initiated at this time by pushing the START key .

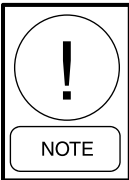

Local vs. Remote control of the start is established by the condition of the “LOCAL-REMOTE START” buttons on the “Evaporator” Screen. A start mode change may only be made with the unit stopped.

When in LOCAL, the start sequence begins as soon as the operator pushes the START key  on the front of the chiller control panel.

When in REMOTE, the “DCS CHILLER REMOTE START CONTACT” at (Across the network interface) must momentarily close to energize and initiate the chiller start sequence. Alternately, the chiller can be started by a remote run contact. The option for remote hardwired start must be configured on the Evaporator Screen. This will be covered in this section.

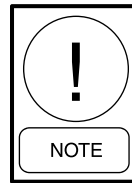

The chilled and condenser water flows must be established by the customer's pump control system or manually by the operator within 45 seconds after a start is initiated in order to close the chilled and condenser water low flow cutout contacts and continue with the start sequence.

- With the above “START INITIATED” signal, the chiller controls start the low stage VSD oil pump and their respective representations on the display indicate a running oil pump. The oil heater shuts down during oil pump operation. A Pre-lube of 50 seconds will be started on the low stage compressor. The VSD Oil Pumps will produce 45 psid (3.10 BarD) pressure for the first 15 seconds of runtime. After 15 seconds, then they will maintain the setpoint of 36 psid (2.48 BarD).
- If the pumps fail to start within 2 seconds after the PLC output is energized, an alarm signal will be transmitted to the DISPLAY for indication and recording.
- Low Head Start**

If the lift requirements of the chiller are less than the Immediate Two Stage threshold, sensed by entering Condenser Water Temperature minus Entering Chilled Water Temperature, the system will start in single stage mode. The low stage motor contactor will engage only after pre-lube is completed. When the starter has completed and the transition to full voltage operation, an auxiliary contact from the starter run (full voltage) contractor is input to the chiller control panel to operate the following:

- The capacity control system will be put into a hold condition in order to establish a level within the economizer vessel. The Economizer Level control valve LCV-116 will start ramping closed to maintain a level in the economizer. The LCV-116 will maintain the economizer level until shutdown. This refrigerant inventory management procedure insures that vast quantities of refrigerant



LD15240

FIGURE 19 - SYSTEM STATUS

aren't accumulated in the evaporator, which can cause liquid carryover.

- b. Once the economizer level has been established, the capacity controls enable. Compressor pre-rotation vanes and hot gas bypass valve will now begin to ramp open / closed respectively at a predetermined rate. See "Capacity Control Operation" for further details on the ramp-up of the controls.

After the interlock is established, the compressor pre-rotation vanes are opened to their minimum position necessary to prevent "surging" during the initial acceleration at start-up.

- c. After the low stage compressor interlock is closed and the minimum vane position is reached, the capacity controls try to maintain the chilled water out temperature. The system status display will display "**LOWSTAGE RUN**" with only the Low Stage compressor running in Single compressor mode.
- d. If the system head exceeds a predetermined Head pressure threshold, the high stage will be prelubed and started. This mode is 2-stage operating mode and will allow the chiller to operate over a wider range of head conditions. The booster stage allows the chiller to produce a greater lift, than a single stage could possibly produce.
- e. As the High Stage Compressor vanes open, the refrigerant path is re-directed from the bypass check valve, into the High Stage compressor. The check valve seals off the bypass path around the High Stage compressor, producing two stages of compression.

6. High Head Start

If the lift requirements of the chiller are greater than the Immediate Two Stage threshold, sensed by entering Condenser Water Temperature minus Entering Chilled Water Temperature, the system will start in two stage mode. The low stage motor contactor will engage only after pre-lube is completed. When the starter has completed and the transition to full voltage operation, an auxiliary contact from the starter run (full voltage) contractor is input to the chiller control panel to engage the High Stage starter, which started its pre-lube process only seconds after the Low stage pre-lube process had started.

- A. The capacity control system will be put into a hold condition in order to establish a level within the economizer vessel. The Economizer Level control valve LCV-116 will start ramping closed to maintain a level in the economizer. The LCV-116 will maintain the economizer level until shutdown. This refrigerant inventory management procedure insures that vast quantities of refrigerant aren't accumulated in the evaporator, which can cause liquid carryover.

- B. Once the economizer level has been established, the capacity controls enable. Compressor pre-rotation vanes and hot gas bypass valve will now begin to ramp open / closed respectively at a predetermined rate. See "Capacity Control Operation" for further details on the ramp-up of the controls.

After the motor starter interlock is established, the compressor pre-rotation vanes are opened to their minimum position necessary to prevent "surging" during the initial acceleration at start-up.

The capacity controls operate to control chiller capacity in response to process water outlet temperature. The hot gas will ramp closed first while maintaining a minimum vane anti-surge position on the vanes. If programmed for Load Matching, the High Stage vanes are reacting to the motor current of the Low Stage compressor. The capacity controls are further described by flowchart in a later section. The system status display will display "**SYSTEM RUN**" with both stages of compression running.

If the Head on the chiller reduces to below a programmable threshold, the High Stage compressor will be dropped offline. Under this condition, the low stage compressor will continue to run and attempt to make capacity with a reduced requirement for lift.

Ramp-Up of Capacity Controls

The ramp-up feature is used to provide a gradual increase in chiller capacity during start-up.

Refer to the "Capacity Control Diagrams" in *Figure 25 on page 51* along with the following to best understand the operation.

The DISPLAY will indicate when the "CHILLED WATER OUT TEMPERATURE CONTROL" is in the manual mode.

This occurs when the unit is shut down, during ramp-up and when the "DEMAND LIMITER" or the "EVAP LOW PRESS. OVERRIDE" control signal is being used to control the capacity of the chiller.

With the unit stopped, the “CHILLED WATER OUT TEMPERATURE CONTROL” is in manual, its setpoint is equal to the chilled water out temperature and its output is equal to the PRV signal. (When in manual, the controller drives its output to the same as the tieback valve, which would be 0% with unit off.)

When start is initiated, the PRV signal goes to the “PRV START-UP SIGNAL” value. This value determines the position of the compressor pre-rotation vanes at the instant the main motor starts. It is adjusted to keep the starting load on the motor low but also allow enough gas flow through the compressor to prevent surging at start-up.

After the compressor motor starts, the “START-UP SIGNAL” value increases at a rate determined by the “PRV Ramp Rate” setpoint until it reaches PROGRAMMED CAPACITY CONTROL FUNCTIONS, the “MIN PRV SIGNAL” value (minimum PRV signal allowed with the compressor running), and then holds at this value.

The “HGV RAMP CONTROL” output begins to decrease at this time to start closing the hot gas bypass valve.

After the motor power drops below the “DEMAND LIMITER” setpoint, its output signal increases rapidly to 100%. LSR-3 and LSR-4 will then select the lower output signal.

The hot gas valve will continue closing during the ramp-up period at a rate determined by the “HGV RAMP TIME” setpoint as long as the “HOT GAS CONTROL” output remains below the HGV ramp output signal.

During the ramp-up period, the “CHILLED WATER OUT TEMP. CONTROL” setpoint will track the chilled water out temperature and its output will be driven to equal the PRV signal. The vanes will continue to open at a rate determined by the “PRV RAMP RATE” setpoint as long as the “CHILLED WATER OUT TEMP. CONTROL” remains in “MANUAL.”

If during ramp-up the capacity increases sufficiently to lower the chilled water outlet temperature to less than 2° above the desired setpoint, the “CHILLED WATER OUT TEMP. CONTROL” is changed to the automatic mode and its output now changes in response to load changes.

If the chilled water temperature continues to fall, the “CHILLED WATER OUT TEMP. CONTROL” output will decrease causing the hot gas valve and PRV to move to whatever positions are required to maintain the chilled water at setpoint and provide stable compressor operation.

When the ramp-up is completed (PRV signal at 100%) and/or the “CHILLED WATER OUT TEMP. CONTROL” is changed to automatic, its setpoint will return to whatever setpoint is stored in the PLC memory at that time (if in “LOCAL SETPOINT” mode), or will change to the PROGRAMMED remote setpoint (if in “REMOTE SETPOINT” mode). The setpoint will change slowly at a rate determined by the “SETPOINT RAMP” rate value to the desired value.

The above tracking and reset tieback controls disable the “CHILLED WATER OUT TEMP. CONTROL” during shutdown and ramp-up when other logic is in control and provide for a smooth transition to automatic control as required.

The “CAPACITY CONTROLS DIAGRAM” Screen will indicate which signals are currently in control of the pre-rotation vanes and valves during start-up.

System Shutdown

1. The chiller may be shutdown normally by momentarily closing the DCS REMOTE STOP CONTACT to energize Input across the network (refer to the protocol listing manual), or by depressing the local **STOP** key . Also, the chiller may be stopped via a safety control, in which event the Quantum™ LX displays and records the cause of shutdown.
2. Avoid shutting down the chiller while still under high head conditions. Backspin can be violent and damaging to the compressor. Discharge check valves are installed to prevent damage on unplanned stops of the chiller; however it is best practice to unload the chiller before shutting down. During a controlled stop unload procedure, the vanes are brought closed, the and Hot Gas Valve is opened to drop the head across the vessels. Process Chiller controlled stops are generally shorter than Comfort Cooling Controlled stops.

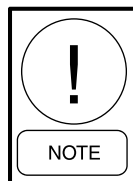

The following safeties are “Hardwired” to stop the chiller regardless of the condition of the Output controlling the motor starter:

Emergency Stop (Pull to Stop Pushbutton) Compressor Discharge High Pressure Cutout

- a. The compressor pre-rotation vanes are closed to minimize back flow of gas through the compressor. The hot gas valve is opened

(above freezing conditions) to equalize the condenser pressure with the evaporator. The sideload valve is ramped closed. These actions are taken to reduce backspin of the compressor on shutdown.

- b. The compressor motor start relays are de-energized to open their contacts and de-energize the motor starter control circuits.
- c. The subcooler level control valve is opened fully to drain the refrigerant out of the subcooler.
- d. The water flow, and low oil pressure safety logic is inactivated to prevent nuisance alarms.
- e. The anti-recycle timer is activated at this time. The anti-recycle (cool down) time depends on the description under “Anti-recycle operation” at the end of this section.

During this time, further restarts of the motor are prevented.

- f. The compressor post-lube timing logic is enabled and the VSD pumps will run for 3 minutes to cool the oil system with the auxiliary water solenoid valve opened.

- 3. The condenser water flow may be shut off after the postlube cycle is complete.

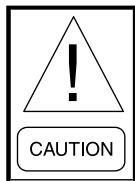

If the shutdown is caused by Low Refrigerant Pressure, this could be an indication of a major refrigerant leak. In this event, the chilled water flow must be maintained to prevent freeze-up and damage to the tubes.

- 4. Five seconds after the oil pumps shut down, the compressor oil heaters are energized if the temperature of the oil requires it.

Anti-Recycle

1. Cold Starts

If the motor has been shutdown for 8 hours, the cool down (anti-recycle) time will be 2 minutes for the first and second cold start.

To start a third time, the chiller must be off for 30 minutes.

Any additional starts would be considered hot starts.

2. Hot Starts

If the chiller has been running less than 20 minutes, the cool down time will be the difference between 45 minutes and the hot motor running time since last start. For example, if chiller has run 5 minutes since last start, cool down time = 45-5 = 40 minutes.

If the chiller has been running 20 minutes or longer, the cool down time will be 2 minutes.

Excessive Starts

When the motor is started, a 24-hour counter is enabled. During the next 24-hour period, a total of 7 additional starts are allowed. If 8 starts are attempted in any 24-hour period, the chiller start logic is locked out for a minimum of 3 hours.

CAPACITY CONTROL OPERATION

Chiller Applications

Much of the function of the Control System is dedicated to chiller capacity control. Sensors register system conditions that are used to infer the total cooling load and make necessary adjustments to the system components.

There are two primary mechanisms by which cooling capacity is controlled: pre-rotation vanes, and the hot gas bypass valve. The primary directive of the Control System is first to maintain safe operating conditions, then to keep the system online, and finally to efficiently maintain setpoints.

The interaction of capacity control subsystems is complex, and can be better understood by referring to the capacity control diagram in the accompanying figures.

The capacity control philosophy of the YORK CYK chiller control system allows efficient, fully automated control, without need for operator intervention. The CYK control system is designed for industrial process applications. This control system also monitors and displays all safety aspects of the chiller and provides alarms and a shutdown if safety limits are exceeded. If operator intervention is required, manual controls are provided on the Electronic Operator interface, for all electric actuators.

The Capacity Controls algorithm automatically seeks out the most efficient operation of the CYK chiller. The pre-rotation vanes are automated to obey the temperature controller to maintain process water production.

In cases of low load, the pre-rotation vanes automatically throttle and are limited to a minimum anti-surge position, which is calculated from a head curve. To provide light duty operation, the hot gas recycle valve is seamlessly throttled open according to temperature demands. This keeps the centrifugal compressor out of surge and maintains process water production.

In cases of high load, which exceeds the motor current usage, the capacity controls algorithm automatically unloads the system to maintain a restriction on power consumption. In the same way, conditions of high discharge pressure or low suction pressure override the production of process water in the interests of keeping the chiller system online.

In cases of light load and low head, the Booster compressor is dropped offline, the intercooler bypassed, and the unit will be run with the Low-Stage compressor like a single-stage YK chiller.

In cases of high load and high head (ice building duty), the Booster compressor is brought back online to perform the additional gas compression. The unit runs in compound mode with the flash economizer in the cycle.

Basic Control Model

The analog model in *Figure 20 on page 40* is derived from the pneumatic control systems that predated modern digital controllers. In pneumatics the lines connecting the controllers and select relays contained air at between 3 and 15 psi, representing the analog control values. In digital implementations of this model the connection points are variables which represent the loading and unloading values of the controllers in terms of 0% to 100%. The controller generates an output of 100% at a fully loaded state, and 0% at a fully unloaded state. Controllers may be direct or reverse acting depending on the relationship between the process variable and setpoint.

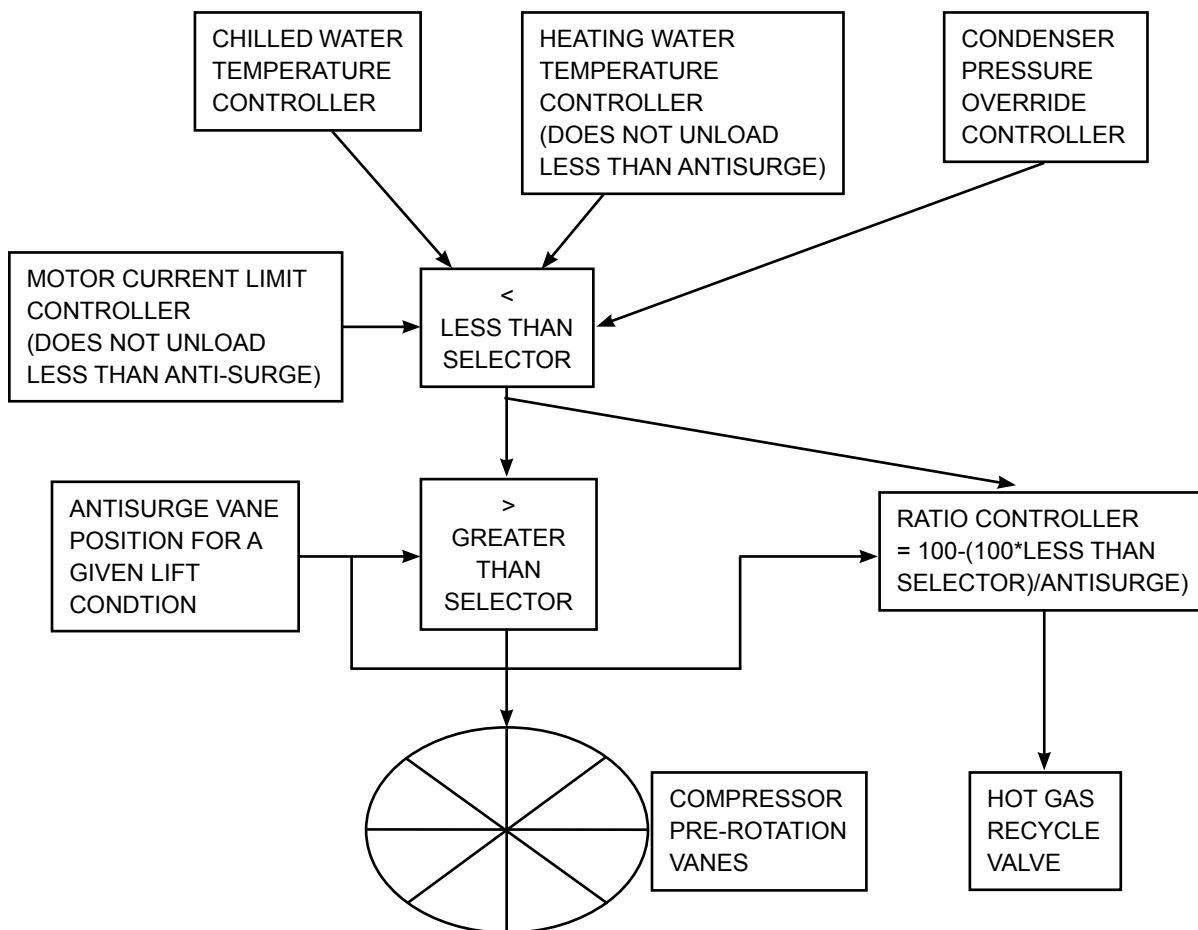

FIGURE 20 - CONTROL MODEL

In this figure, the vanes do not unload past the Anti-Surge map. As the Low Selector result value decreases past the value of the Anti-Surge map, the hot gas valve begins to open ratio metrically. At a fully unloaded command out of the Low Selector, the hot gas will be fully open.

Gain scheduling is important for this implementation to separate the dynamic reaction that the pre-rotation vanes have on the system, from the reaction response of the hot gas valve on the system. The tuning parameters of the controllers are changed to accommodate the change in output device when the result of the ratio controller becomes greater than zero. The control theory is discussed in greater detail later in this section.

Heat Pump Applications

The CYK chiller also becomes a heat pump when the capacity controls system is switched mode to control hot leaving water out of the condenser vessel. Leaving condenser water is the process variable of the heat pump. The leaving chilled water controller becomes a low temperature override in this mode. However there are considerations that must be made to create an effective control system around the “Water to Water Heat Pump”. In a typical chiller refrigerant cycle, it is assumed that the evaporator conditions remain relatively constant, and the condenser conditions are allowed to be adjusted to maintain the most efficient operating conditions.

The Heat Pump is limited to produce heat on the available heat extracted from the chilled water loop. If there is insufficient load on the chilled water loop, then hot gas will generate as much heat as it can to make up the lack of source heat from the chilled loop. More importantly the Heat Pump must have sufficient load on the condenser (heating) side to carry away the heat of compression of the system. The Design working pressure of the condenser vessel is the limiting factor of the hot water production. On the condenser side of the heat pump, if the load is less than the heat of compression load plus the refrigeration effect, the system will not be able to stay online as the total heat generated in the heat pump is not removed from the heating water loop and will accumulate causing a high pressure shutdown.

Heat Pump mode and Chiller/Heat Recovery capacity controls operation are mutually exclusive operational modes. The Chiller mode produces cold water at setpoint, and any hot water recovered simply a benefit. The inverse is also true. Whichever limitation is reached first becomes the limiting factor and the Heat Pump will unload based on low water temperature or high discharge pressure.

In practice for chillers this means the condenser temperature is kept as low as economically possible, and still maintaining a minimum lift requirement that produces the required differential pressure required for the sizing of the expansion valve. What we find in a chiller when running fully loaded at a low head the inlet guide vanes can be very closed, and the chiller still maintains a full load chilling output. As the lift requirements increase as the condenser temperature raises, the inlet guide vanes must open more to maintain a fully loaded condition. More work must be done to overcome the lift requirements.

In a WTWHP application the head alleviation found on an ARI chiller profile is not present. At light loads the chiller can run at a lower head. When a WTWHP must unload the lift requirements actually increase. In a chiller the difference between inlet and outlet cold water temperature goes down, and the difference between hot water inlet and outlet temperatures goes down. But the temperature difference between the Hot and Cold water sides goes up, increasing the lift requirements on the compressor. At a satisfied or unloaded state, the Hot Water leaving the WTWHP will be hot as possible, and the Cold Water will be as cold as possibly allowed.

A centrifugal compressor must move a minimum amount of refrigerant gas flow with relation to the lift requirements to keep out of surge. As the lift requirements go up, as the load goes down, the minimum mass flow requirements of the compressor increase. This presents a problem, in that the Centrifugal WT-WHP cannot effectively unload as much as a chiller application. Experience tells us that this value is about 40% of rated heating capacity.

Recall that a chiller can actually run with no load on the evaporator, and that the temperature difference can be nearly zero. However if our useful heat is measured at the condenser side we quickly realize that due to the heat of compression, and inherent inefficiencies of the refrigeration effect, the heating capacity must always be non-zero. This minimum capacity of the heat pump must always be satisfied, or the unit must be switched off.

Role of Hot Gas Bypass

The natural solution on a centrifugal chiller application is that when the surge line is approached with a decrease in load, the mass flow cannot be decreased without aerodynamic instability; therefore the hot gas bypass is used to supplement mass flow. This supplemental mass flow creates a source of inefficiency in

the refrigeration cycle and allows the chiller to run at lower evaporator loads than it could without hot gas. This isn't particularly helpful in a WTWHP from a standpoint of unloading the hot water capacity. The shift of importance is placed on the heating water side. In order to reduce capacity on the heating water side, the chiller must remain efficient as possible. Adding a source of inefficiency, such as Hot Gas Bypass, creates more heat than without. This will actually increase the energy being deposited in the heating water system.

Conversely, the Hot Gas Valve has an important role, in that when the heat source of the evaporator water side is insufficient, the WTWHP can simply become inefficient by opening the hot gas valve to generate heat. There may be an economic breakpoint at which running the WTWHP with Hot Gas is less efficient than using fossil fuels for heat.

The Importance of Heat Balance

It becomes apparent that having a heat sink outside to WTWHP to use as much energy as possible is important. A Heat Balance must be maintained at all times. If the external system does not reject the energy from the heating water side, the energy is returned to the entering condenser water of the WTWHP. This increases the temperature of the loop. As the chiller unloads, it reaches that point at which the minimum mass flow through the compressor is reached. If this trend were left to continue, the hot water loop would increase in temperature, until it reached the equivalent design working pressure of the condenser vessel. The WTWHP must be switched off before the high pressure safety threshold is reached.

It becomes apparent that a WTWHP should never be oversized for an application. The Heat Pump is limited to produce heat on the available heat extracted from the chilled water loop. If there is insufficient load on the chilled water loop, then hot gas recycle will generate as much heat as it can to make up the lack of source heat from the chilled loop. More importantly the Heat Pump must have sufficient load on the condenser (heating) side to carry away the heat of compression of the system. The Design working pressure of the condenser vessel is the limiting factor of the hot water production. On the condenser side of the heat pump, if the load is less than the heat of compression load plus the refrigeration effect, the system will not be able to stay online as the total heat generated in the heat pump is not removed from the heating water loop and will accumulate causing a high pressure shutdown.

Therefore, if the minimum heat energy produced by the heat pump is not removed into the heating load, the discharge pressure will start to rise. Once the discharge pressure rises above the PC-113 discharge pressure override limit, the system will open the hot gas valve in an attempt to alleviate the pressure. When this occurs the "Death Spiral" of the heat pump has begun. If the process heating load does not begin to absorb the energy produced by the heat pump, then the centrifugal heat pump will shut down on high pressure safety.

If the heating load establishes equilibrium with the heat pump while its hot gas valve is open, then the hot gas recycle effect will false load the heat pump keeping the temperature satisfied possibly at an elevated discharge pressure. This is not a desirable condition, and therefore the excursion into such a situation should be avoided by rejecting all the available energy provided by the heat pump before a high pressure override occurs. This can be likened to orbiting the event horizon of a black hole. The discharge pressure must be made to be less than the Discharge Override Setpoint, in order for the hot gas valve to close. To break away from this condition, an increase in heating requirement must be placed on the heat pump to shut the hot gas so that the false loading of the recycle gas can be eliminated and the "Death Spiral" avoided.

Major Capacity Control Devices

Compressor Pre-rotation Vanes

The compressor pre-rotation vanes (PRV's) are internal guide vanes in the suction flow path to the impeller wheel. The PRV's are used to throttle the refrigerant flow through the system as a means of controlling capacity in response to the leaving chilled water temperature. If the leaving chilled water temperature falls below the setpoint, the PRV's are partially closed until the net cooling is reduced and the leaving chilled water returns to setpoint.

In the event of high motor power, the capacity control signal is over-ridden and the compressor PRV's are closed to keep the motor power down. On start-up, the PRV's are closed to reduce the starting load torque of the compressor.

The compressor pre-rotation vanes are closed on shutdown to reduce backflow of high-pressure gas from the condenser, which might otherwise cause the compressor to spin backwards at a high rate of speed.

A shaded pole motor operates the mechanical pre-rotation vane linkage, at the compressor. The shaded pole motor is operated by a contact closure to either open or close the vanes. A pre-rotation vane position potentiometer senses the position of the vanes and reports it to the controller as a percentage open value.

On Startup the low stage PRV's are opened to minimum vane. As the high stage compressor is started; the vanes are locked to together so that the high stage tracks ahead of the low stage at a predetermined offset percentage.

There is also an operational mode to balance motor current usage by controlling the high-stage vanes on the basis of motor current sharing. This algorithm allows the compressors to share compression ratios, while the low stage is controlled by the leaving process Water Temperature Controller. Vane opening is limited by pressure overrides and independently by motor current overrides.

Hot Gas Bypass Valve

The hot gas bypass valve is used primarily at low loads to maintain a minimum suction gas flow required by the compressor for stability. When the compressor has reduced capacity to its minimum flow (via pre-rotation vane throttling), further capacity reductions are accomplished by opening the hot gas bypass valve. This maintains the flow to the compressor by bypassing the discharge gas back to the compressor suction.

However, the hot gas flow replaces the useful evaporation in the cooler since the compressor flow is at minimum. Thus, the net chilling capacity is reduced (albeit not efficiently).

The minimum suction flow or minimum compressor PRV position will vary. As the differential "head" pressure is lowered (due to colder condenser water) the compressor is capable of stable operation at lower loads. The programming in the chiller panel thus uses the differential "HEAD" pressure to establish when the hot gas may be needed.

- On a water chilling application, this valve goes open on shutdown.
- On a brine application this valve is closed at shutdown to allow the pressures to drop slowly. Allowing low-pressure cold refrigerant from the evaporator to migrate into the condenser would create a freezing hazard for the condenser water.

The hot gas valve is a rotary ball type control valve with an electric actuator. The control signal is a modulating direct current signal, which is converted to a position by an electric actuator. The valve will be fully closed at low signal and open at high signal. Refer to the Wiring Diagram to see the 4-20mA Control Signal wiring. The Output Scaling screen allows factory selection of the proper output signal.

Subcooler Liquid Level Valve LCV-114

The subcooler liquid level valve controls the refrigerant liquid level in the subcooler located in the bottom of the condenser to maintain the proper amount of subcooling and provide the most efficient operation at all loads.

This valve is opened after shutdown to allow a slow change in pressure between evaporator and condenser. The pressure in the condenser forces the liquid out of the condenser into the economizer and the evaporator. Allowing low-pressure cold refrigerant from the evaporator to migrate into the condenser would create a freezing hazard for the condenser water. It opens at start-up and then slowly closes until it reaches the position dictated by the liquid level control PID instruction in the Quantum LX logic.

The liquid level valve is a rotary ball type control valve with an electric actuator. The control signal from the Quantum LX is modulated direct current, which is converted to a position by an electric actuator. The valve will be fully closed at low signal and open at high signal.

Economizer Liquid Level Valve LCV-116

The Economizer liquid level valve controls the refrigerant liquid level in the economizer to maintain a good liquid seal between the flash gas in the top of the economizer and the liquid to the evaporator, this provides the most efficient operation at all loads.

The liquid level valve is a rotary ball type control valve with an electric actuator. The control signal from the Quantum LX is modulating direct current, which is converted to a position by an electric actuator. The valve will be fully closed at low signal and open at high signal.

Economizer Bypass Valve LCV-117

The Economizer Bypass Valve is normally closed. It is used as a subcooler level control valve in system conditions when flow thru the economizer is reduced. This is manifested by the LCV-114 subcooler control valve controlling at 100% open and the subcooler level is rising. The LCV-117 and LCV-114 are essentially split ranged, with the LCV-117 valve at the high end of the controller. The Bypass control valve generally comes into operation when there is high refrigerant volume flow, or in single stage operation.

The liquid level valve is a rotary ball type control valve with an electric actuator. The control signal from the Quantum LX is modulating direct current, which is converted to a position by an electric actuator. The valve will be fully closed at low signal and open at high signal.

Interstage Gas Sideload Valve PCV-116

The interstage sideload valve controls refrigerant flash gas, from the economizer to the second stage compressor impeller wheel when required to maintain a minimum pressure differential between the economizer and the evaporator.

At normal conditions, the interstage valve will remain fully open during compressor operation and close on shutdown to reduce compressor backspin.

This valve remains closed for after start-up to allow the subcooler level controller to establish a liquid level in the subcooler and then slowly opens when the High Stage Compressor comes online.

The interstage valve is a rotary butterfly type control valve with an electric actuator. The control signal from the Quantum LX is a digital output through a double pole relay. The valve will be fully closed at low signal and open at high signal.

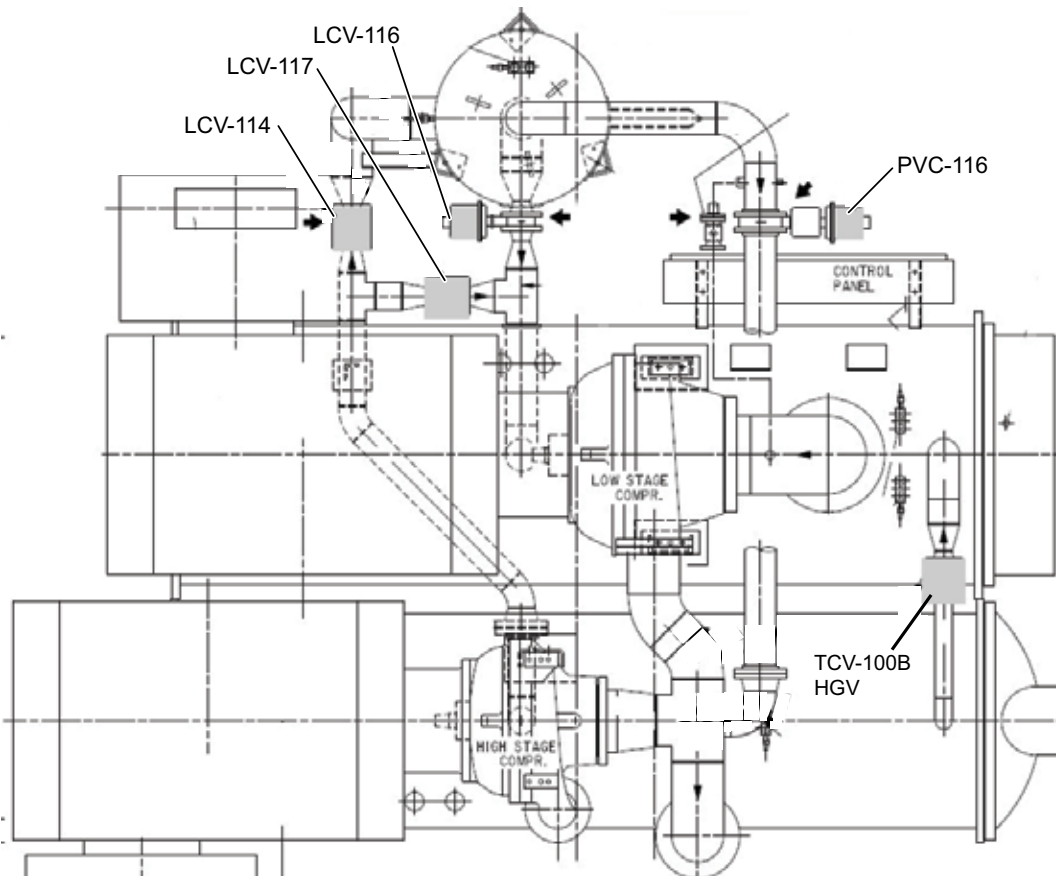

LD15239

FIGURE 21 - VALVE LOCATIONS

Programmed Capacity Control Functions

Chilled Temperature Control

Using the input signal from a temperature sensor in the leaving chilled water line, this control provides an output signal, which decreases as water temperature drops below set point to reduce the capacity of the chiller. When override and anti-surge conditions are satisfied, the temperature control subsystem may dominate. Since temperature control is the highest function associated with capacity control, its task must be concurrent and compliant with all other subsystems and subsystem directives. It indirectly controls the hot gas valve, and pre-rotation vanes in its attempt to maintain the chilled water temperature setpoint while keeping the compressor out of surge.

Heat Pump Temperature Control

Using the input signal from a temperature sensor in the leaving condenser water line, this control provides an output signal, which increases as water temperature drops below set point to increase the capacity of the chiller. When override and anti-surge conditions are satisfied, the temperature control subsystem may dominate. Since temperature control is the highest function associated with capacity control, its task must be concurrent and compliant with all other subsystems and subsystem directives. It indirectly controls the hot gas valve, and pre-rotation vanes in its attempt to maintain the condenser water temperature setpoint while keeping the compressor out of surge. The Chilled Temperature Control automatically acts as an override in Heat Pump mode, by providing a control loop to keep the water leaving the evaporator from becoming dangerously cold. The two temperature controls act thru LSR-1 selector.

Dynamic Override Controls

There are four operating parameters that are primarily concerned with the safe operation of the system: evaporator pressure, condenser pressure, economizer pressure, and motor load. If any of these parameters were to exceed the limits defined by the setpoints, it could lead to a shutdown of the chiller by the safety setpoints. Maintaining chiller operation is the function of the Dynamic Override subsystem.

This power override control function uses the motor power input signals to limit capacity. When one of the motor powers exceeds the setpoint, the control puts out a decreasing signal. The LSR-2, LSR-3 and LSR-4 will

then pass this lower signal on to close the compressor pre-rotation vanes, thus reducing the demand on the motor and returning the motor demand limit to below the maximum threshold.

The pressure override systems prevent a system operation condition from shutting down a chiller prematurely. The pressure override loop controllers maintain the chiller operation just within the safe operational limits of the vessels, until system conditions return to design.

The discharge pressure override produces an unloading effect on the chiller if the cooling water to the chiller goes above design. If the chiller were not unloaded in this condition, the high-pressure cutout would shut the chiller down, and no cooling would be done. The economizer pressure override operates the same way, to protect the pressure limitations of the economizer vessel.

The low evaporator pressure override is a key override in preventing the unit from either freezing or going down on low evaporator conditions. A system overshoot, or a low temperature transition in process water can result in a low suction pressure condition. During startup, the condensing pressure may initially be low. This can cause the refrigerant to back up. If this occurs, the low level of evaporator liquid uncovers a portion of the tube bundle, thereby reducing the heat exchanger performance, and lowering the evaporator pressure. The low evaporator pressure override unloads the chiller rapidly, and often opens the hot gas valve to try to maintain a suction pressure in the chiller. As the fault condition subsides, the override backs off and returns the chiller to normal temperature controlled operation.

Anti-surge

Compressor surge is an undesirable condition occurring at low partial loading in which the system head pressure exceeds the dynamic pressure developed at the compressor discharge volute, causing localized reverse fluid flow through the impeller accompanied with loud noise and mechanical stresses. Opening the hot gas bypass valve, and keeping the vanes at a calculated position according to head mitigates surge. Keeping the compressor out of surge is the function of the anti-surge subsystem. The anti-surge system is based on a straight-line approximation of the compressor surge curve.

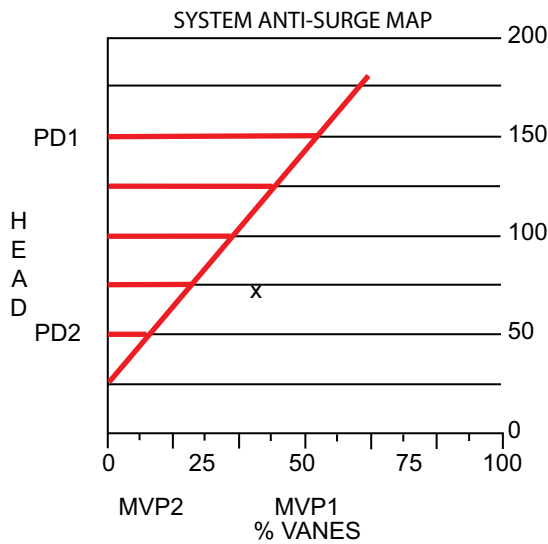

LD15231

FIGURE 22 - SYSTEM ANTI-SURGE

The anti-surge line is biased to the right of the actual surge line. When the compressor needs to move left on the map, and move less mass flow, the vanes can only be reduced so far, before a lack of mass flow causes a surge condition. The anti-surge system supplements

mass flow to the compressor by using the Hot Gas Bypass valve. This allows the chiller to be unloaded without danger of surge. Once the anti-surge system has been set for the maximum head condition, and the minimum head condition, the compressor is protected from surge. The point represented by the intersection of PD1 and MVP1 is the worst case operating condition of the compressor, with high head and low load. The other condition that defines the anti-surge line is at low head and low load, represented by the intersection of PD2 and MVP2. The shaded area of the left side of the map is the surge area. The vanes cannot close more than a given percentage for a given head condition, defined by this line. As the capacity control system unloads the chiller, the Hot Gas Bypass valve is opened proportionally to maintain stable operation and control the process.

There are two sets of parameters for anti-surge. One set defines the map of the single stage compressor system, another set defines the 2-stage operating mode with both compressors running.

Anti-surge override acts at HSR-1 on the capacity controls diagram.

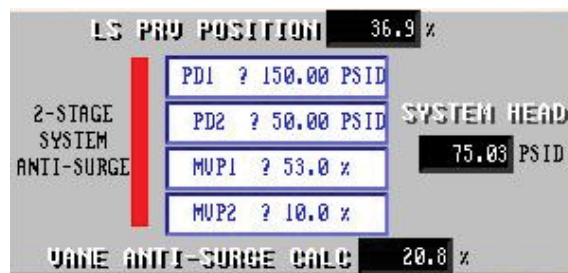
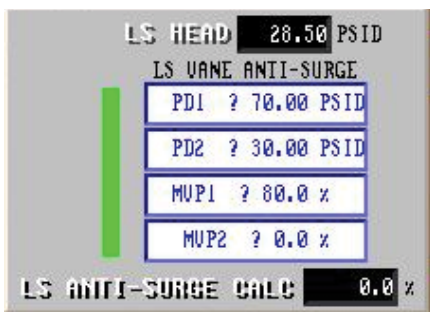

LD15298

FIGURE 23 - PARAMETERS FOR ANTI-SURGE

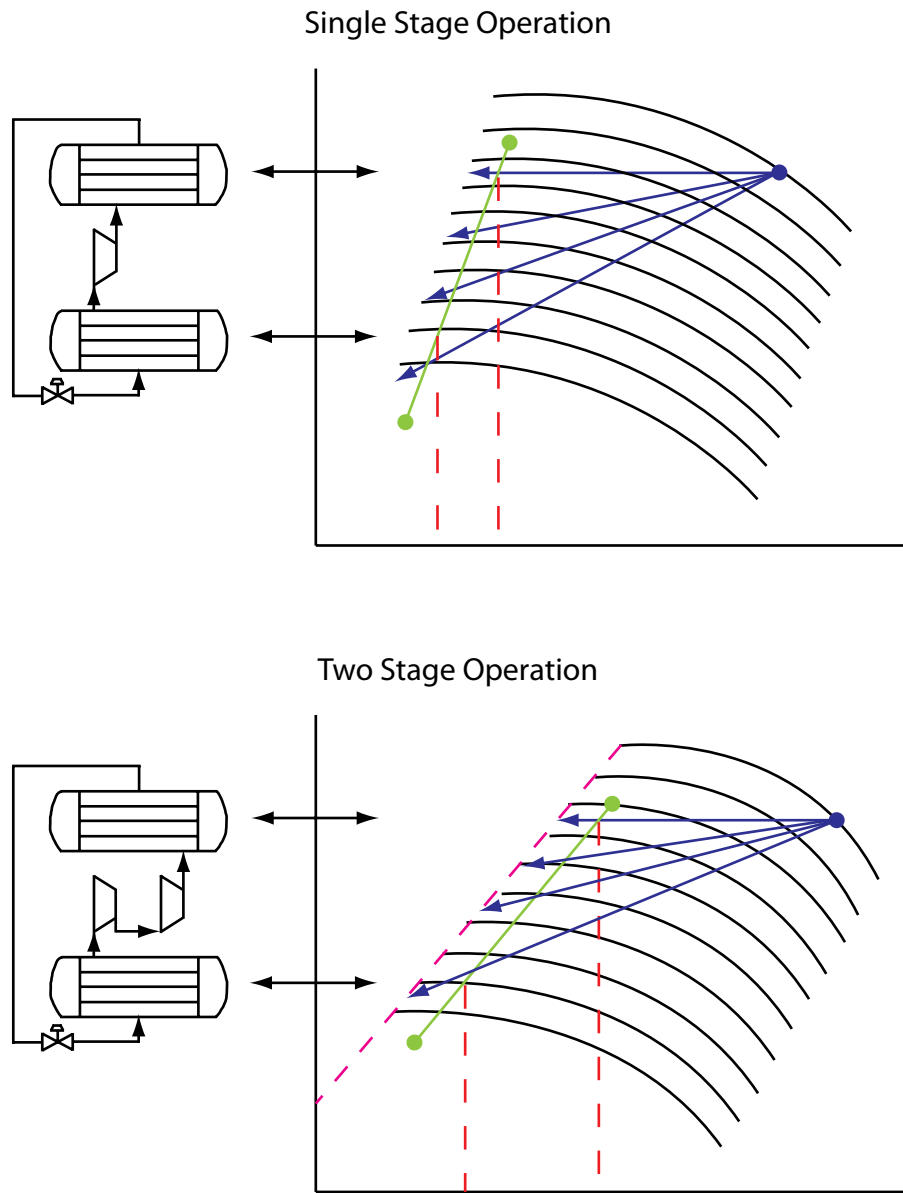

LD15278

FIGURE 24 - STAGE OPERATIONS

Anti-Surge Calculation

The anti-surge tuning values are based on estimated part load conditions and minimum vane signals required at these conditions to prevent unstable operation (surging):

	Compressor Differential (Head) Pressure	Minimum PRV Signal Setpoint for Stable Operation
High Head (PD1)	185 psid	MVP1 = 35% Open
Low Head (PD2)	120 psid	MVP2 = 12% Open



It is very important that this control be adjusted to suit chiller operating conditions to achieve maximum efficiency of operation.

ANTI-SURGE TUNING

Repeat this procedure for both LS ANTI-SURGE CALC and 2-STAGE SYSTEM ANTI-SURGE CALC, sets of parameters.

- With the chiller running in automatic, take the condensing conditions to the highest inlet temperature attainable in the system (without tripping on high discharge pressure). Increase tower inlet temperature or reduce tower flow.
- At the highest condensing temperature, start reducing the load on the chiller, by reducing the flow, or decreasing the inlet temperature. This will cause the capacity control system to back the vanes in an unload sequence.
- If the chiller surges before the Hot Gas valve begins to open, then the anti-surge line must move right on the map.
- If the chiller never surges down to minimum load, then the anti-surge parameters are adequate for protection, but may not be most efficient.
- During the unload sequence, record the operating head as PD1.
- Increasing and decreasing the parameter MVP1 will move the anti-surge line right and left on the map. Listen for a surge, and move the anti-surge line right several percent, to increase refrigerant flow, by supplementing hot gas.

- Repeat the procedure for low head operation.
- At the lowest condensing temperature, start reducing the load on the chiller, by reducing the flow, or decreasing the inlet temperature. This will cause the capacity control system to back the vanes in an unload sequence.
- If the chiller surges before the Hot Gas valve begins to open, then the anti-surge line must move right on the map.
- If the chiller never surges down to minimum load, then the anti-surge parameters are adequate for protection, but may not be most efficient.
- During the unload sequence, record the operating head as PD2.
- Increasing and decreasing the parameter MVP2 will move the anti-surge line right and left on the map. Listen for a surge, and move the anti-surge line right several percent, to increase refrigerant flow, by supplementing hot gas.

The plant condenser water control system will determine the actual high and low head conditions depending on the range of condenser water temperature allowed.

If actual operating conditions are different than those shown above, you must enter the new values for the anti-surge parameter calculation to produce the required output signals as shown in the following example:

	Compressor Differential (Head) Pressure	Minimum PRV Signal Setpoint for Stable Operation
High Head (PD1)	?? psid / ?? bar	MVP1 = ??% Open
Low Head (PD2)	?? psid / ?? bar	MVP2 = ??% Open

The “ANTI-SURGE MIN PRV POS” output (Y%) is calculated based on the actual calculated differential pressure (head) as follows:

$$PD (Head) = (Compressor Discharge Pressure) - (Evaporator Pressure)$$

$$Y\% = (PD - PD2) \times (MVP1 - MVP2) / (PD1 - PD2) + MVP2$$

at High Head (92 psid), $Y\% = (92 - 40) \times (38 - 12) / (92 - 40) + 12 = 38\%$

at Medium Head (66 psid), $Y\% = (66 - 40) \times (38 - 12) / (92 - 40) + 12 = 25\%$

at Low Head (40 psid), $Y\% = (40 - 40) \times (38 - 12) / (92 - 40) + 12 = 12\%$

Hot Gas Control Tuning

The “HOT GAS CONTROL” is automatically adjusted to achieve full hot gas (100% output change) as a decreasing load causes the “CHILLED WATER OUT TEMP. CONTROL” output to drop below the “ANTI-SURGE (MIN. PRV POSITION)” output to 0%.

The “HOT GAS CONTROL” output is calculated based on the “ANTI-SURGE (MIN PRV POSITION)” output signal and the actual capacity control signal (input %) as follows:

$$\text{Output \%} = 100 \times \text{LSR-3 \%} / \text{HSR-2 \%}$$

If the chiller was operating at the above low head condition (HSR-2 =12%), the outputs would be as follows as the load decreases causing the capacity control signal to drop to 0%.

Capacity Control Signal at 12%

$$\text{Output \%} = 100 \times 12 / 12 = 100\% \text{ (Valve Fully Closed)}$$

Capacity Control Signal at 5%

$$\text{Output \%} = 100 \times 5 / 12 = 41.7\% \text{ (Valve Partially Open)}$$

Capacity Control Signal at 0%

$$\text{Output \%} = 100 \times 0 / 12 = 0\% \text{ (Valve Fully Open)}$$

Load Matching Control

Load matching is the control system that controls the vane operation of the High Stage compressor. This programmed control function uses the Low Stage motor load as a Setpoint signal. The process variable is the High Stage motor load. It uses proportional plus reset control to provide an output signal which increases as the current goes above the setpoint to open the High Stage Vanes and maintain a balance of compression ratios. Conversely, this option can be deactivated in favor of a fixed offset vane control, which is sometimes better with variable loads. The load matching control can be trimmed with a bias to attain an optimum interstage operating condition, for the economization cycle of the economizer.

Capacity Controls Tuning

The PID controls are configured using the following tuning parameters:

SP = Setpoint

P = Proportional

I = Integral Gain / Reset Time (Minutes/Repeat)

D = Derivative Gain / Rate (Minutes)

The tuning values are estimated only and may require adjustment depending on actual chiller operating conditions. See “Graphic Display Description” for details on entering new tuning values on the “CAPACITY CONTROLS TUNING” screen.

Tuning Parameters

The PID controller calculation (algorithm) involves three separate parameters; the proportional, the integral and derivative values. The *proportional* value determines the reaction to the current error, the *integral* value determines the reaction based on the sum of recent errors, and the *derivative* value determines the reaction based on the rate at which the error has been changing. The weighted sum of these three actions is used to adjust the process via a control element such as the position of a control valve or the power supply of a heating element.

By tuning the three constants in the PID controller algorithm, the controller can provide control action designed for specific process requirements. The response of the controller can be described in terms of the responsiveness of the controller to an error, the degree to which the controller overshoots the setpoint and the degree of system oscillation.

Some applications may require using only one or two modes to provide the appropriate system control. This is achieved by setting the gain of undesired control outputs to zero. A PID controller will be called a PI, PD, P or I controller in the absence of the respective control actions. PI controllers are particularly common, since derivative action is very sensitive to measurement noise, and the absence of an integral value may prevent the system from reaching its target value due to the control action.

PID Controller Theory

This section describes the parallel or non-interacting form of the PID controller.

The PID control scheme is named after its three correcting terms, whose sum constitutes the Control Variable (CV). Hence:

$$\text{CV}(t) = P \text{ out} + I \text{ out} + D \text{ out}$$

where

P_{out} , I_{out} , and D_{out} are the contributions to the output from the PID controller from each of the three terms, as defined below.

Proportional Term

The proportional term (sometimes called *gain*) makes a change to the output that is proportional to the current error value. The proportional response can be adjusted by multiplying the error by a constant K_p , called the proportional gain.

The proportional term is given by:

$$P_{\text{out}} = K_p e(t)$$

where

P_{out} : Proportional term of output

K_p : Proportional gain, a tuning parameter

e : Error = $SP - PV$

t : Time or instantaneous time (the present)

A high proportional gain results in a large change in the output for a given change in the error. If the proportional gain is too high, the system can become unstable. In contrast, a small gain results in a small output response to a large input error, and a less responsive (or sensitive) controller. If the proportional gain is too low, the control action may be too small when responding to system disturbances.

In the absence of disturbances, pure proportional control will not settle at its target value, but will retain a steady state error that is a function of the proportional gain and the process gain. Despite the steady-state offset, both tuning theory and industrial practice indicate that it is the proportional term that should contribute the bulk of the output change.

Integral Term

The contribution from the integral term (sometimes called *reset*) is proportional to both the magnitude of the error and the duration of the error. Summing the instantaneous error over time (integrating the error) gives the accumulated offset that should have been corrected previously. The accumulated error is then multiplied by the integral gain and added to the controller output. The magnitude of the contribution of the integral term to the overall control action is determined by the integral gain, K_i .

The integral term is given by:

$$I_{\text{out}} = K_i \int_0^t e(\tau) d\tau$$

where

I_{out} : Integral term of output

K_i : Integral gain, a tuning parameter

e : Error = $SP - PV$

t : Time or instantaneous time (the present)

τ : a dummy integration variable

The integral term (when added to the proportional term) accelerates the movement of the process towards setpoint and eliminates the residual steady-state error that occurs with a proportional only controller. However, since the integral term is responding to accumulated errors from the past, it can cause the present value to overshoot the setpoint value (cross over the setpoint and then create a deviation in the other direction).

Derivative Term

The rate of change of the process error is calculated by determining the slope of the error over time (i.e., its first derivative with respect to time) and multiplying this rate of change by the derivative gain K_d . The magnitude of the contribution of the derivative term (sometimes called *rate*) to the overall control action is termed the derivative gain, K_d .

The derivative term is given by:

$$D_{\text{out}} = K_d \frac{d}{dt} e(t)$$

where

D_{out} : Derivative term of output

K_d : Derivative gain, a tuning parameter

e : Error = $SP - PV$

t : Time or instantaneous time (the present)

The derivative term slows the rate of change of the controller output and this effect is most noticeable close to the controller setpoint. Hence, derivative control is used to reduce the magnitude of the overshoot produced by the integral component and improve the combined controller-process stability. However, differentiation of a signal amplifies noise and thus this term in the controller is highly sensitive to noise in the error term, and can cause a process to become unstable if the noise and the derivative gain are sufficiently large.

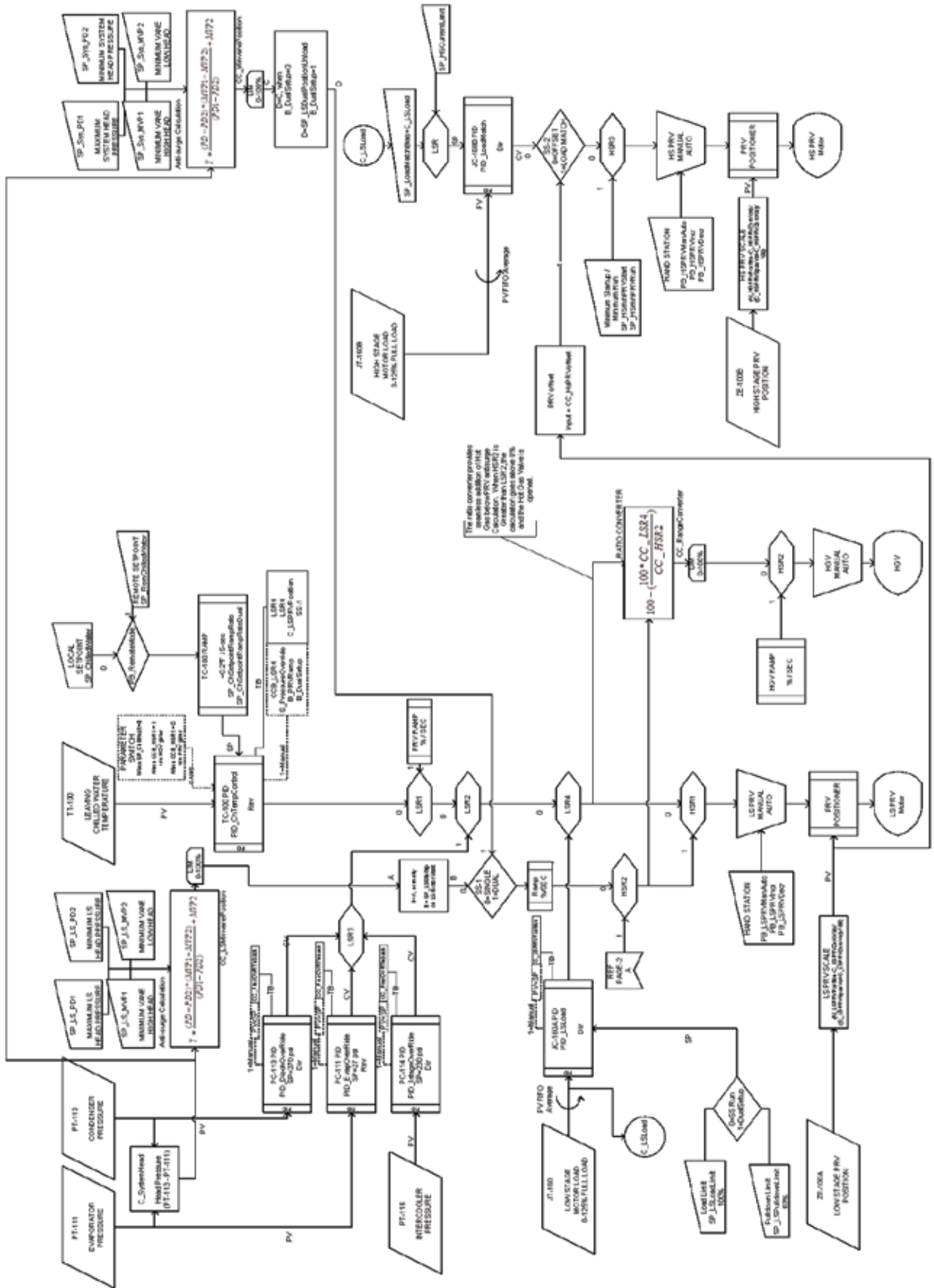
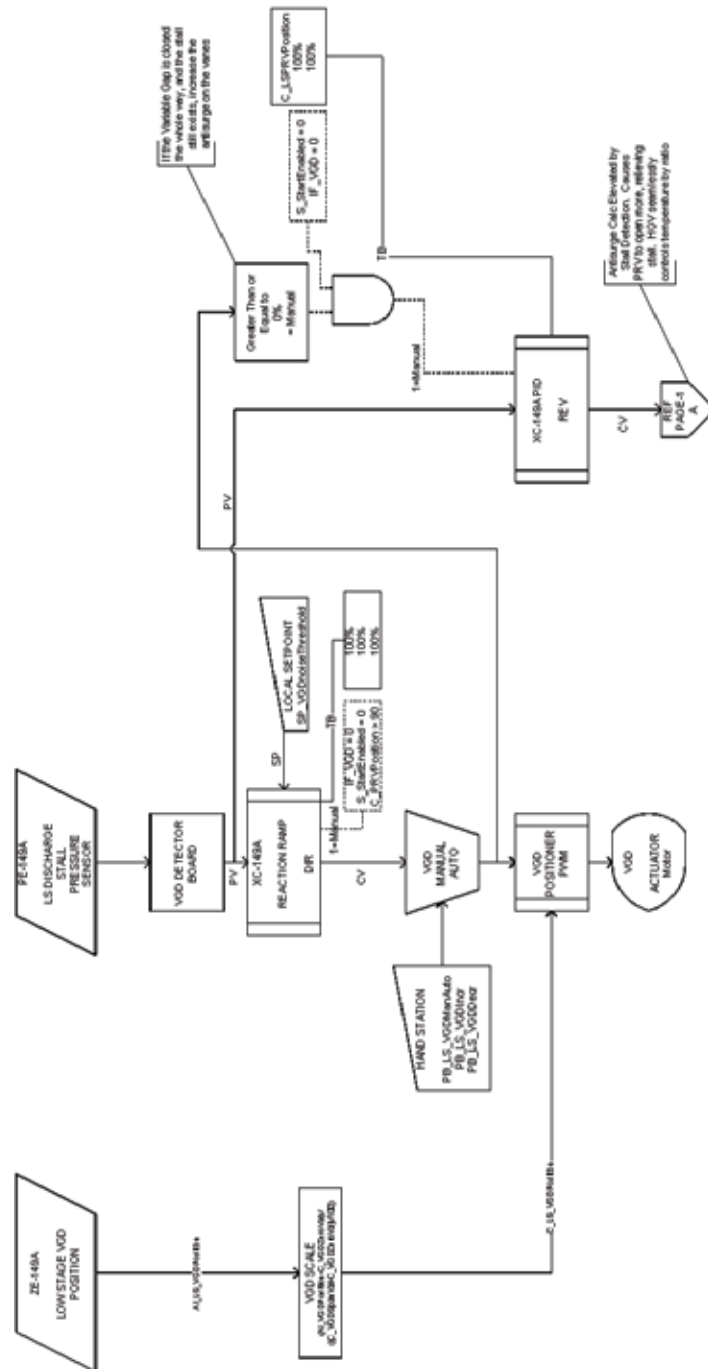

FIGURE 25 - CAPACITY CONTROL DIAGRAMS

LD15290



LD15291

FIGURE 23 - CAPACITY CONTROL DIAGRAMS (CONT'D)

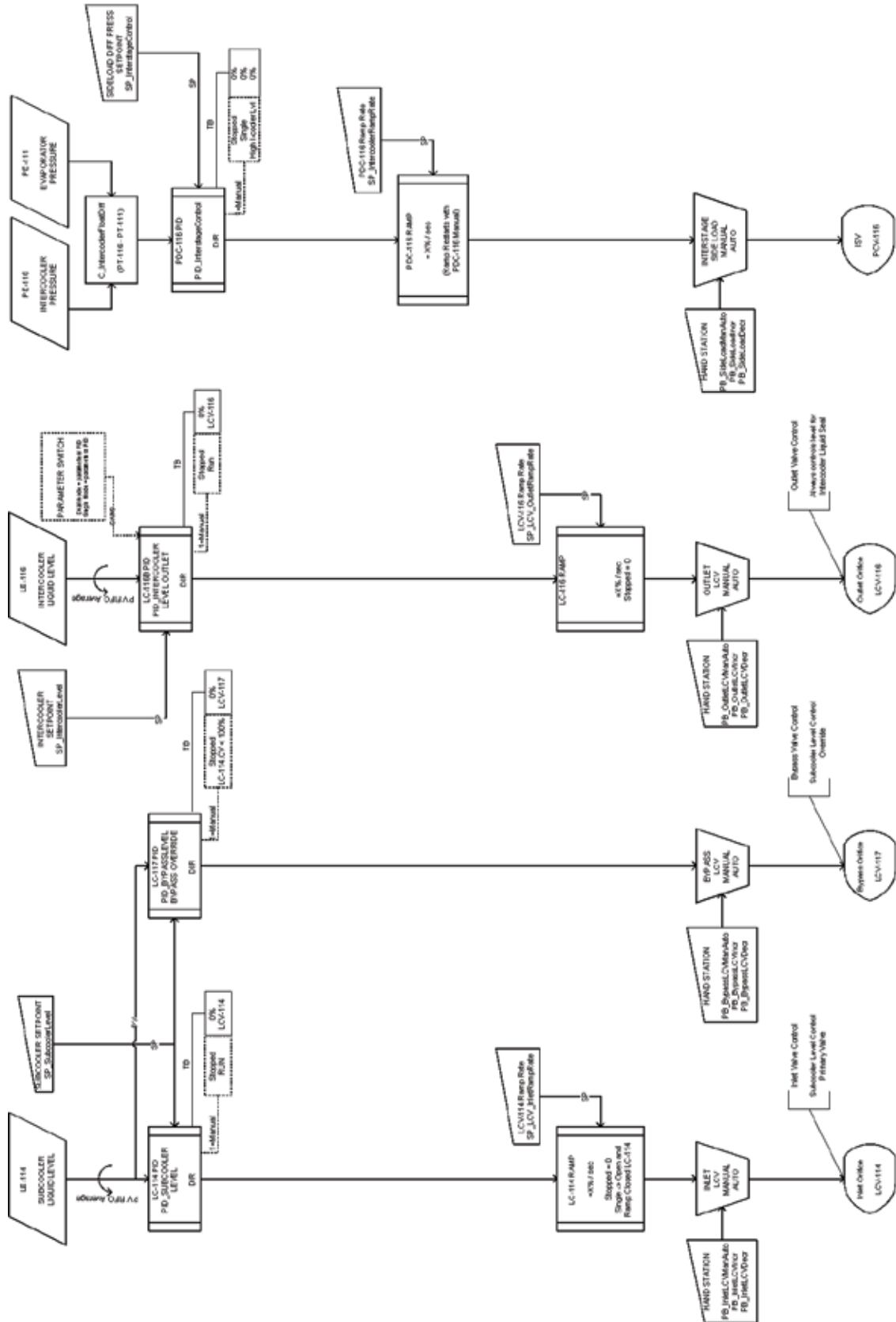

FIGURE 23 - CAPACITY CONTROL DIAGRAMS (CONT'D)

THIS PAGE INTENTIONALLY LEFT BLANK

SECTION 3 - QUANTUM LX CONTROL PANEL



FIGURE 26 - QUANTUM™ LX GRAPHIC DISPLAY

The Quantum™ LX Control Center is a microprocessor based control system for R134a centrifugal chillers. It controls the leaving chilled liquid temperature via Pre-rotation Vane controls and has the ability to limit motor current via control of the Pre-rotation Vanes. It is compatible with YORK Solid State Starter (optional), Medium voltage solid state starters, and electromechanical starters.

The panel comes configured with a full touchscreen LCD Graphic Display mounted in the middle of a keypad interface. The graphic display allows the presentation of several operating parameters at once. In addition, the operator may view a graphical representation of the historical operation of the chiller as well as the present operation. For the novice user, the locations of various chiller parameters are clearly and intuitively marked. Instructions for specific operations are provided on many of the screens.

The graphic display also allows information to be represented in both English (temperatures in °F and pressures in PSIG) and Metric (temperatures in °C and pressures in kPa or Bar) mode. The advantages are most apparent, however, in the ability to display many languages.

The Control Center continually monitors the system operation and records the cause of any shutdowns. This information is recorded in memory and is preserved even through a power failure condition. The user may

recall it for viewing at any time. During operation, the user is continually advised of the operating conditions by various status and warning messages. In addition, it may be configured to notify the user of certain conditions via alarms. A complete listing of shutdown, status, and warning messages is detailed in the DISPLAY MESSAGES portion of this manual.

There are certain screens, displayed values, programmable setpoints and manual control shown in this manual that are for Service Technician use only. They are only displayed when logged in at SERVICE access level or higher. The setpoints and parameters displayed on these screens are explained in detail in this section. These parameters affect chiller operation and should never be modified by anyone other than a qualified Service Technician. They are shown in this manual for reference only.

Also included are detailed descriptions of chiller features, such as the Refrigerant Level Control, Variable Speed Drive Oil Pump, Hot Gas Bypass, High Speed Thrust Bearing Proximity Probe, Remote Setpoints, and Standby Lubrication.

The Control Center expands the capabilities of remote control and communications. By providing a common networking protocol through the Building Automation System (BAS), YORK Chillers not only work well individually, but also as a team. This new protocol allows increased remote control of the chiller, as well

as 24-hour performance monitoring via a remote site. In addition, compatibility is maintained with the present network of BAS communications. The chiller also maintains the standard digital remote capabilities as well. Both of these remote control capabilities allow for the standard Energy Management System (EMS) interface:

1. Remote Start
2. Remote Stop
3. Remote Leaving Chilled Liquid Temperature Setpoint adjustment (0 to 10VDC, to 4 to 20mA).
4. Remote Condenser Water Setpoint adjustment (0 to 10VDC, or 4 to 20mA).
5. Safety Shutdown Contacts



The chiller operating program resides in the Control Center Microboard. The Quantum™ LX Control Center could be equipped with either of the following boards:













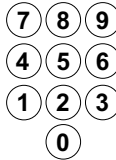

- Prior to 2011 the BCM motherboard 025-43703-000 was supplied.
- Chillers shipped after January of 2011 use an Avantech motherboard 025-44606-001. Any replacements in the field will use the upgrade kit 025-44606-000.

Navigating The Control Panel

Navigation through the various screens of the operator interface panel is highly intuitive. The touchscreen allows the user to select from the available screen displays and make setpoint adjustments.

The following is a list of the labeled keys on the keypad and the actions that occur when they are pressed.

KEY	FUNCTION
	STOP - When the compressor is running in <i>Manual Mode</i> , pressing this key immediately stops the compressor by placing it into Stop Mode. The compressor is stopped regardless of any other conditions.
	START - When in <i>Manual Mode</i> , this key places the compressor unit into the Start Mode for running.
	UNLOAD VALUE - Not Used

	LOAD VALUE - Not Used
	ALARM SILENCE - Immediately silences a sounding alarm and turns off the alarm annunciation device that is connected to this panel.
	MANUAL - Not Used
	NUMERALS [0 - 9] - The numerical keys are used to enter a value in a data field.
	DECIMAL [.] - This key is used when entering a decimal value in a data field.
	[+ /-] - When changing a value in a data field, this key toggles the value between negative and positive.
	BACKSPACE - Pressing this key will cause the current location of the cursor to backup one position per key depression. When changing a value in a data field, this key will delete the selected character.
	UP ARROW - Provides upward navigation within the <i>MAIN MENU</i> window.
	TAB - When in the mode of changing setpoints, pressing this key will cause the cursor to jump to the next data entry field.
	LEFT ARROW - When in the mode of changing setpoints, this key is used to go to the previous data entry field. When the <i>MAIN MENU</i> is shown, pressing this key will cancel the window.
	DOWN ARROW - Provides downward navigation within the <i>MAIN MENU</i> window.
	RIGHT ARROW - When in the mode of changing a data entry field, this key is used to go to the next character.
	ENTER - When changing data in a data entry field, this key will accept the change. This key is also used to select items on Menu Windows.
	SUBMIT - After changing a setpoint value, use this key to enter (submit) the change.
	MENU - Calibrate Touch Screen

SCREEN SELECTION

Graphical, animated screens display data and provide a means for accessing various system components. Screens indicate all aspects of operation and sensor data pertaining to the particular component depicted.

At the top of each main screen is displayed the system status, present date and time, local or remote control source and system access level. Sub-screens may also be available for some system components, providing additional data access. Screens are selected by selecting the touch cell with the screen name on it.

Display Features

Display features are those that are available for viewing only, and include read-only parameters such as temperatures and pressures. Display features may be given as numerical values or graphics in the form of bar graphs, red indicator lights, or animated graphs.

Interactive Screen Features

Various aspects of chiller operation may be adjusted by the operator within the appropriate screen. Touch keys allow the operator to select a key appropriate to the adjustments required. Some interactive controls are depicted graphically while others, such as setpoints, appear as entry fields in which the operator may enter values directly.

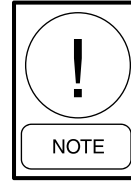

Programmable Features

The setpoints define the operation and limits of the chiller. These setpoints can be changed by operators in the field. These setpoints are stored on the compact Flash card.



Setpoints are not lost after power is interrupted. However, we suggest that a list of Setpoints be recorded and stored safely to facilitate reentry, in case there is a need to return to the original settings.

3

1. The data entry fields are identified by a black box with a white interior. The data is shown in black text. When on a screen that has adjustable setpoints, tab  to the setpoint box that you wish to modify (or select it on a web browser). Once the data field has been selected, the background turns blue, and the text turns white.
2. The current value of that setpoint is shown. Use the keypad to enter the new value. Typing a new value will completely erase the old value.
3. Press the keypad ENTER  key to input the new data in the data entry field and to move to the next data entry field.
4. Once all entries/changes have been made, pressing the SUBMIT  key will save the setpoint changes to memory.
5. If the value is out of bounds, an error message box displays the proper range of values. Press the OK touch key to acknowledge the error message. Re-enter a correct value.

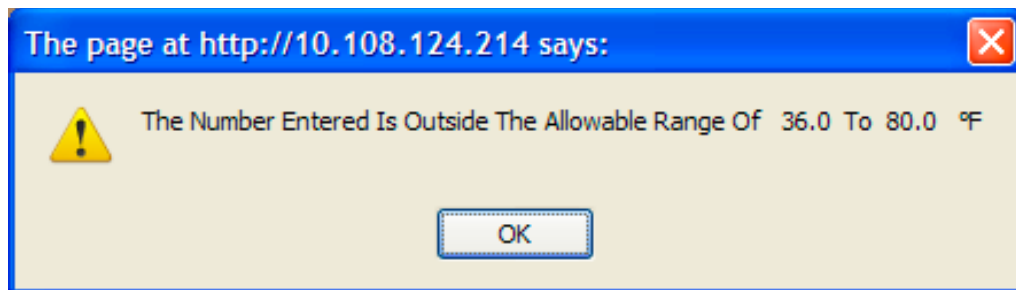
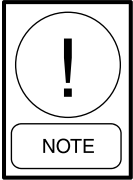

FIGURE 27 - ALLOWABLE RANGE

LD15326

Programmable features are supplied as entry fields (Black Letters in a White Box) into which numeric values may be entered. These include setpoints and PID tuning parameters as well as setpoint values and anti-surge parameters.

The chiller Control System has four access levels: VIEW, OPERATOR, SERVICE and FACTORY. This instruction is intended only as a service manual. As such, screens depicted here are the system parameters available at the SERVICE and FACTORY levels of access, which require user login.

The system is provided with four levels of security access.

User Access Level 0: VIEW

The View mode allows non-setpoint screens to be viewed, but no setpoints to be changed. The View mode may not take manual control of the capacity devices.

User Access Level 1: OPERATOR

Operator is the privileged user. The operator may look at any status item, but may not access safety setpoint screens. The operator also may change the chilled water and demand limit setpoints. The operator may use the Manual / Auto stations. The Operator user's password is 9675

User Access Level 2: SERVICE

The service user is privileged to access any chiller screen. This user may also change setpoints. Service level may adjust tuning parameters, and perform general configuration and setup functions

User Access Level 3: FACTORY

This user is privileged above all other users. Factory level may adjust Scaling, Input / Output assignments, or Alarm and Shutdown settings.

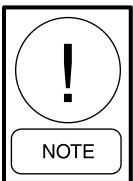

System adjustments should be performed only by a qualified service person. Read all instructions carefully before making adjustments

User Login

In order to gain access to service authorized features, it is necessary to log into the system. On the home screen is the **LOGIN** key. Selecting this key brings up a display depicting the control panel keypad. Enter the user access level and then the password and press the return key on the keypad. The System Status display at the top of the screen shows the current login access level.

Pressing **LOGOUT** on the Home screen will log out the current user and return the access level to VIEW.



Manual Automatic Stations

Manual automatic stations allow analog control of valves and vanes. The analog process control system is based on a 0 – 100% range. The automatic control system drives the valve or vanes with a percentage of drive signal. The operator interface allows an experienced technician to take manual control of a device. Pressing the button marked AUTO toggles the device into a manual control state. The button turns red and the word MANUAL appears. Pressing MANUAL will toggle the device into an automatic state.

While in manual control, the OPEN (INCREASE) or CLOSE (DECREASE) buttons may be used to manipulate the valve or vane. The bar graph on the right shows the actual position of the valve or vane. The automatic bar graph shows where the automatic control system wants the device to be.

To provide a bumpless transfer of manual back to automatic operation, devices such as the Low Stage PRV's must be above antisurge to return to automatic operation. The Hot Gas Bypass valve shown in this example has an inhibit function. The Hot Gas Valve must be within 5 percent of its automatic value before it can be returned to automatic operation.

Screen Indicators

On (engaged) and Off (disengaged) signals are represented by "LED" symbols. A red LED symbol is ON , and a grey LED symbol is OFF .

The Shutdown Trip indicator will remain in the alarm state until the RESET pushbutton is pressed after the conditions have returned to normal.

MANUAL control value displayed here

AUTOMATIC control value displayed here 0-100% open of valve position

Pressing toggles between AUTO and MANUAL mode

OPEN or CLOSE valve by pressing

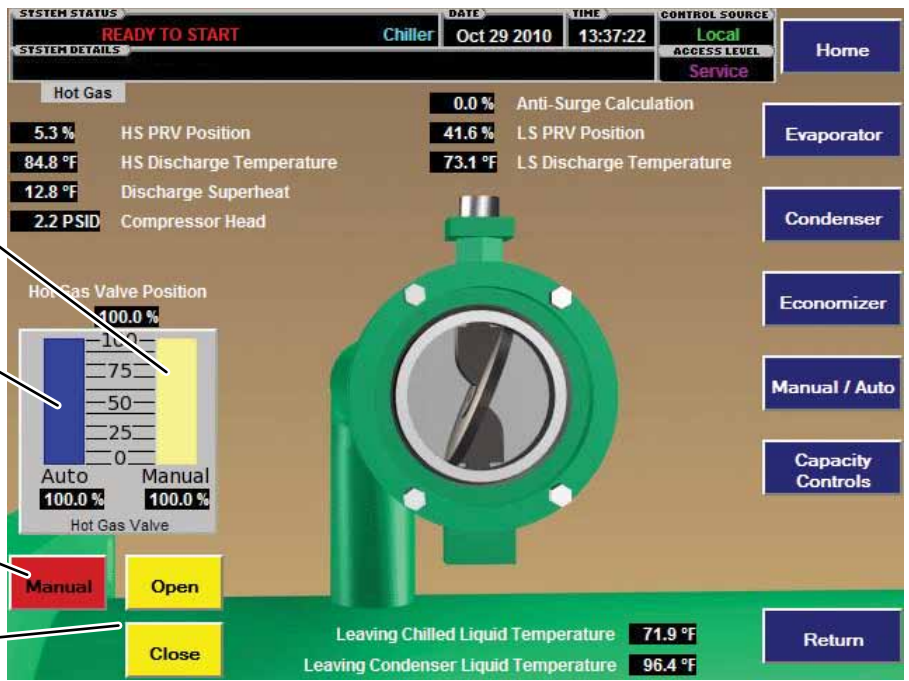

LD15283

FIGURE 28 - MANUAL AUTOMATIC STATIONS

Status Bar

The status bar will indicate the running condition of the unit. The leftmost top SYSTEM STATUS area describes the operational mode. The right portion of this block states whether the capacity controls are configured for CHILLER operation or HEAT PUMP operation.

The SYSTEM DETAILS block at the bottom shows alarm messages. Pressing **SYSTEM RESET** on the Home screen will attempt to reset any alarms or trips.

EXAMPLE 1



LD15327

EXAMPLE 2



LD15328

The main status indicator bar at the top of the screen will display the SYSTEM STATUS with the following messages:

TABLE 8 - SYSTEM DETAILS

SYSTEM STATUS	MESSAGE
READY TO START	Unit is ready to start in Local Mode
REMOTE START ENABLED	Unit is ready to start in Remote Mode
START / LS PRELUBE = XXX sec	Locally initiated start / Prelube cycle
REM START / LS PRELUBE = XXX sec	Remote initiated start / Prelube cycle
SYSTEM RUNNING 2-STAGE	System Running with two stages
SYSTEM COASTDOWN = XXX sec	System stopping / Postlube cycle
SYSTEM TRIPPED	System Tripped Offline
ANTIRECYCLE = XX:XX	Anti-recycle Countdown
LOW STAGE RUNNING	Unit running with One stage only
VANES CLOSING	Control Stop initiated
REMOTE LOCKOUT	Remote mode selected / not confirmed
HS START / PRELUBE = XX sec	High Stage booster is starting
RUNNING / DYNAMIC OVERRIDE	System Running but override in control
FAULT / ERROR	Processor is not responding

Web Browser

The web browser interface can be viewed from any desktop or laptop computer, which has access to the network that the compressor panel is attached to. To change screens, setpoints, etc., you simply use a mouse and the keyboard to view and change data. All screens that are shown will have a several buttons on the right hand side of the screen. Most screens will have four buttons, and one setpoint box. The three buttons are:

[Start Refresh] [Stop Refresh] – This button(s) appears immediately below the [Menu] button. This is actually a toggle button, as it changes function from Start Refresh to Stop Refresh each time it is clicked on. When the button shows as Start Refresh, a setpoint box will appear below it, with a time value displayed. The time value determines how often the display screen will refresh, or update its values. This time value is defaulted to 5 seconds, which means that the display will update all values shown every 5 seconds. Depending on the network connection speed, this updating may interfere

with your ability to change data setpoints, because the screen will refresh while you are entering the data. To solve this, simply increase the refresh time. The other alternative is to toggle the Refresh Button. By pressing [Stop Refresh], screen refreshing will terminate, and the time setpoint box will reappear. In this state, the particular screen that you are viewing will never update the displayed values. Changing to another screen will show the most recent values on the new screen, and then will not update again. So in the Stop Refresh state, screens will only be updated when new screens are accessed. This feature should not be used when monitoring for data. Try to find an acceptable refresh time for the Start Refresh state.

[Submit] – After having made changes to any information, the [Submit] button must be pressed for the controller to accept the new changes. This button performs the same function as the physical [Submit] button on the panel keypad.

CONTROL CENTER



LD15323

FIGURE 29 - CONTROL CENTER

INTERFACE CONVENTIONS OVERVIEW

The new graphical display on each control panel allows a wide variety of information to be presented to the user. Each screen description in this document will begin with a section entitled OVERVIEW which will describe the graphical elements on the screen and give a short summary of the functions available. Each element on the screen will then be categorized into three distinct groups: Display Only, Programmable, and Navigation. Below is a short description of what types of information are included in these groups.

The Programmable values and Navigation commands are also subject to access level restrictions as described below. For each of these elements, an indication is given to show the minimum access level required to program the value or navigate to the subscreen.

DISPLAY ONLY

Values in this group are read-only parameters of information about the chiller operation. This type of information may be represented by a numerical value, a text string, or an LED image.

PROGRAMMABLE

Values in this group are available for change by the user. In order to program any setpoints on the system, the user must first be logged in with the appropriate access level. Each of the programmable values requires a specific access level which will be indicated beside the specified value. All of the programmable controls in the system fall into one of the categories described below:

Change Setpoints

On screens containing setpoints programmable at the OPERATOR access level, a key with this label will be visible if the present access level is VIEW. This key brings up the access level prompt described above. It allows the user to login at a higher access level without returning to the HOME Screen. After login, the user may then modify setpoints on that screen.

Setpoints

The Control Center uses the setpoint values to control the chiller and other devices connected to the chiller system. Setpoints can fall into several categories. They could be numeric values (such as 45.0°F for the Leaving Chilled Liquid Temperature), or they could enable or disable a feature or function.

Manual Controls

Some keys are used to perform manual control functions. These may involve manual control of items such as the Pre-rotation Vanes, variable orifice or oil pump speed. Other keys in this category are used to initiate/terminate processes such as calibrations or reports.

LANGUAGES

The Screens can be displayed in various languages. Language selection is done on the USER Screen. The desired language is selected from those available. Not all languages are available. English is the default language. If a language other than English is being displayed, an English-only speaking person should navigate to the USER Screen using the preceding navigation chart and select English per the USER Screen instructions in this manual.

Home Screen (page 63)

- System Screen (page 65)
- Evaporator Screen (page 67)
- Condenser Screen (page 69)
 - Subcooler Screen (page 71)
 - Hot Gas Screen (page 73)
- Low Stage Compressor Screen (page 75)
 - LS Proximitor Calibration (Low And High Stages) Screen (page 77)
 - PRV Calibration Screen (page 79)
 - Oil Sump (Unified Sump Pressure) Screen (page 81)
 - Oil Sump (Ice Thermal Storage) Screen (page 83)
 - LS Variable Geometry Diffuser Screen (page 87)
- High Stage Compressor Screen (page 89)
 - HS Prox Calibration Screen (page 91)
 - Liquid Cooled Solid State Starter Screen (Optional) (page 93)
- Capacity Controls Screen (page 96)
 - Manual Auto Station (Capacity Control) Screen (page 98)
 - PID Capacity Controls Tuning Screen (page 100)
 - Overrides (Capacity Override Tuning Parameters) (page 102)
 - Anti-Surge Screen (page 104)
- Setup / Diagnostics Screen (page 106)
 - Test Outputs Screen (page 108)
 - Setpoints 1 Screen (page 109)
 - Setpoints 2 Screen (page 110)
 - Pressure Calibration Screen (page 113)
 - Temperature Calibration Screen (page 114)
 - Miscellaneous Calibration Screen (page 115)
 - Digital Input Configuration Screen (page 117)
 - Digital Output Configuration Screen (page 118)
 - Auxiliary Analog Configuration Screen (page 119)
 - Auxiliary Analog Calibration Screen (page 121)
 - Retransmitting Outputs Screen (page 123)
- Economizer Screen (page 124)
- History Screen (page 126)
 - Freeze Screen (page 127)
- Trending Screen (page 128)
 - Trending Setup Screen (page 130)
 - Custom Display Screen (page 131)

HOME SCREEN

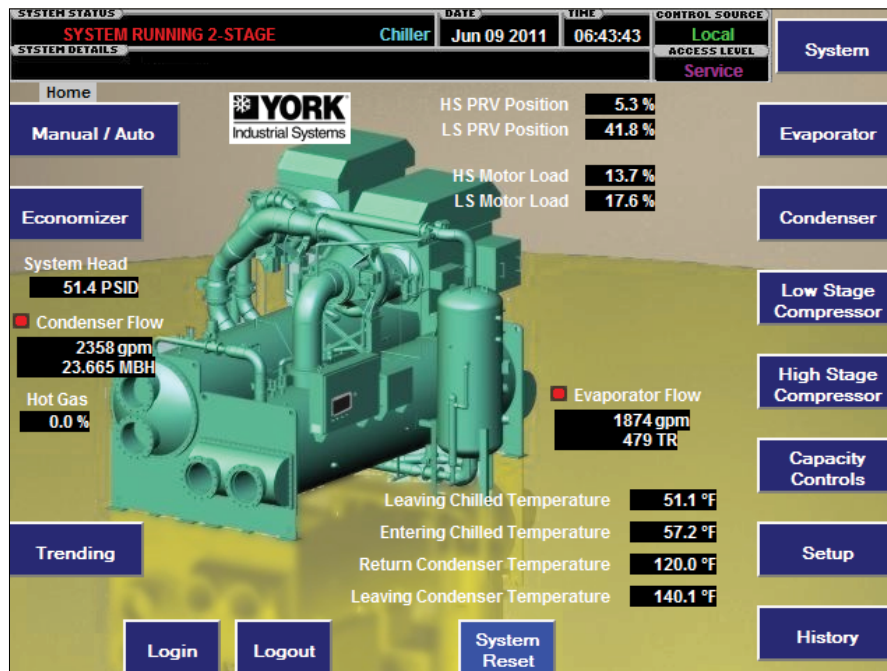

LD15240a

FIGURE 30 - HOME SCREEN

OVERVIEW

When the chiller system is powered on, the above default display appears. The primary values which must be monitored and controlled are shown on this screen. The HOME Screen display depicts a visual representation of the chiller itself.

DISPLAY

HS PRV Position

The High Stage PRV calibrated feedback from the PRV position potentiometer.

LS PRV Position

The Low Stage PRV calibrated feedback from the PRV position potentiometer.

HS Motor Load

Percent of High Stage rated motor load as transmitted from the motor protection relay.

LS Motor Load

Percent of Low Stage rated motor load as transmitted from the motor protection relay.

System Head

The head or lift as calculated from the condenser pressure minus the evaporator pressure.

Hot Gas

The percentage of Hot Gas Valve opening.

Liquid Temperatures

The cooling water and chilled water are measured at the waterboxes of the chiller using ICTD's.

Condenser Flow / Evaporator Flow

The red LED symbol will be on if there is water flow detected across the heat exchanger vessel.

INTERACTIVE

Blue function keys with white letters are screen navigation buttons. Screen access is limited by the security access level of the user.

Login

Pressing this button will bring up a numeric entry box. Press the number keys on the keypad to enter the access code. Press the Enter key after the code has been entered.

Logout

Pressing this button will log the user out of any advance access code, back to the VIEW level of access.

System Reset

This button will attempt to reset any alarms experienced by the control system. Alarms stay active until reset.

PROGRAMMABLE

Manual / Auto

Access Level Required: OPERATOR

Allows the operator to switch between automatic chiller control and temporary manual control of the system devices. In manual control, the device operation and position can be set as desired for troubleshooting or maintenance outside of the normal control routine.

Economizer

Access Level Required: OPERATOR

Returns the display to the Economizer Screen.

NAVIGATION

System

Used to provide additional system information.

Evaporator

A detailed view of all evaporator parameters, including the programmable Leaving Chilled Liquid Setpoints.

Condenser

A detailed view of all condenser parameters, including control of the liquid level functions.

Low Stage Compressor

This screen displays data about the Low Stage Compressor.

High Stage Compressor

This screen Displays data about the High Stage Compressor.

Capacity Controls

Returns the display to view the Capacity Controls Screen.

Setup

This screen provides a single location to program the most common system setpoints. It is also the gateway to many of the general system setup parameters such as I/O configuration, Communications Setup, Software Maintenance, Trending, and diagnostics.

History

This screen provides access to a Time stamped Record of shutdown conditions.

SYSTEM SCREEN

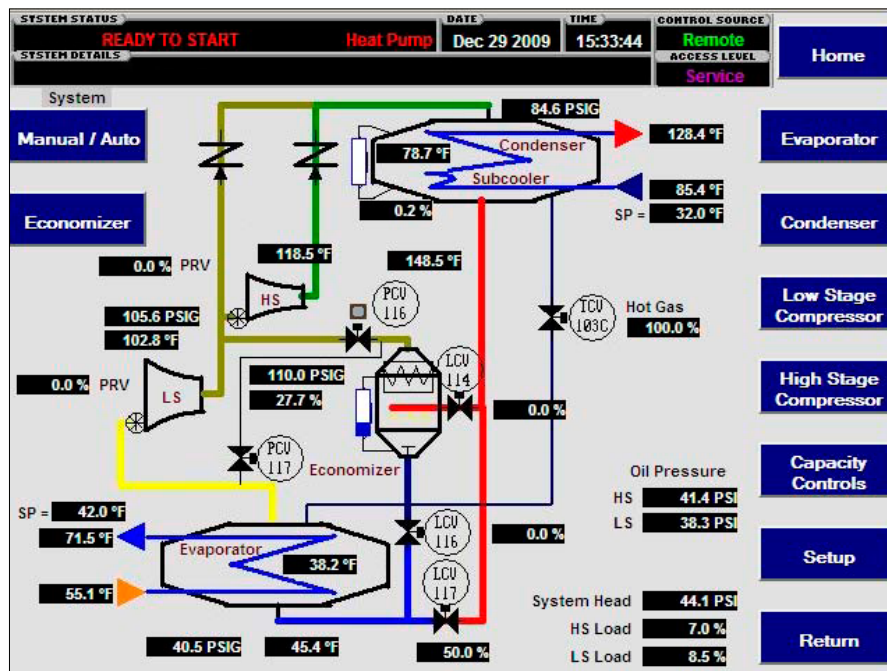

LD15241

FIGURE 31 - SYSTEM SCREEN

OVERVIEW

The system screen of the CYK chiller is a process flow representation of the refrigerant circuit. It shows key pressures, temperatures, levels, and actuator positions around the system at a glance.

DISPLAY

Hot Gas

Displays the percent open valve position of the Hot Gas Valve.

Oil Pressure

Displays the compressor oil pressure.

System Head

Displays the differential pressure across the system.

HS Load

Displays the motor percent amp load.

LS Load

Displays the motor percent amp load.

PROGRAMMABLE

Manual / Auto

Access Level Required: OPERATOR

Allows the operator to switch between automatic chiller control and temporary manual control of the system devices. In manual control, the device operation and position can be set as desired for troubleshooting or maintenance outside of the normal control routine.

Economizer

Access Level Required: OPERATOR

Returns the display to the Economizer Screen.

NAVIGATION

Home

Used to provide additional Home information.

Evaporator

A detailed view of all evaporator parameters, including the programmable Leaving Chilled Liquid Setpoints.

Condenser

A detailed view of all condenser parameters, including control of the liquid level functions.

Low Stage Compressor

This screen displays data about the Low Stage Compressor.

High Stage Compressor

This screen Displays data about the High Stage Compressor.

Capacity Controls

Returns the display to view the Capacity Controls Screen.

Setup

This screen provides a single location to program the most common system setpoints. It is also the gateway to many of the general system setup parameters such as I/O configuration, Communications Setup, Software Maintenance, Trending, and diagnostics.

Return

Returns the display to the previous screen.

EVAPORATOR SCREEN

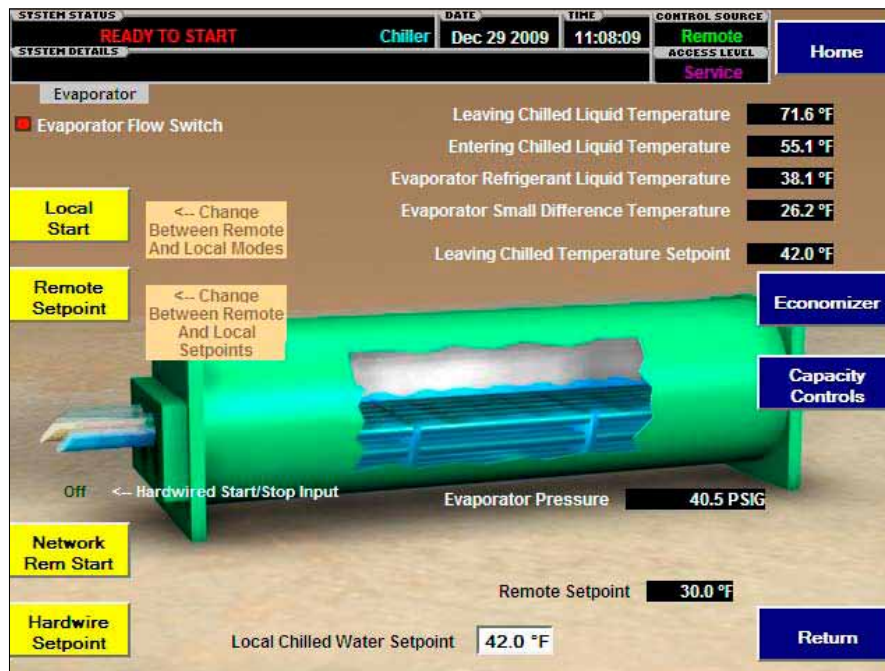

LD15242

FIGURE 32 - EVAPORATOR SCREEN

OVERVIEW

The Evaporator screen shows the parameters associated with the cooler heat exchanger. Flow is indicated by the red LED symbol. Leaving and Entering water temperatures are shown, along with evaporator refrigerant temperature and pressure. The small difference temperature is calculated from the difference between the leaving process liquid and the evaporator refrigerant temperature. A high small difference temperature could indicate fouled tubes or improper charge. The remote chilled water setpoint is also shown for reference.

The ACTIVE leaving chilled water setpoint is shown for reference in the center of the screen.

DISPLAY

Leaving Chilled Liquid Temperature

Displays the temperature of the liquid as it leaves the evaporator.

Leaving Chilled Temperature Setpoint

Displays the present setpoint to which the chiller is operating, whether controlled locally or remotely.

Evaporator Pressure

Displays the present refrigerant pressure in the evaporator.

PROGRAMMABLE

Local Chilled Water Setpoint = XX.X

Access Level Required: OPERATOR

Pressing this button will allow the user to change the leaving chilled water setpoint. Water duty machines are limited to a minimum of 36°F leaving to prevent freezing. Brine duty machines are limited to the specific temperature of the brine concentration. Press Submit to confirm the new setpoint.

INTERACTIVE

Local Start / Remote Start

Access Level Required: SERVICE

This button toggles between a Locally initiated start from the chiller control panel START button, and a remote start from an external source.

Local Setpoint / Remote Setpoint

Access Level Required: SERVICE

This button toggles between the local setpoint as defined by this screen, or a remotely defined setpoint from another source.

Network Remote Start / Hardwired Remote Start

Access Level Required: SERVICE

This button toggles between the sources of the remote start signals. They can either come from the START command from across the network, or from Channel 8 input on the second digital input module. The remote status of the signal is shown above this button.

- The remote START word is: A-B **N119:10** or **Modbus 00001** (write a 1 to start)
- The remote STOP word is: A-B **N119:11** or **Modbus 00002** (write a 1 to stop)

When in Hardwired start mode, opening the Hardwired contact initiates a controlled stop.

- Remember remote Start / Stop / System Reset across the communications network must be set to Logic **HIGH** momentarily to initiate the command. The bit must be returned to Logic **LOW** after the command has been received.

Network Remote Setpoint / Hardwired Setpoint

Access Level Required: SERVICE

This button toggles between the source of the remote setpoint. It can either be sourced from A-B **N102:98** or Modbus **47299** across the network, or from a remote analog signal shown on the wiring diagram. Remember that analog values are times 10.

When the system is configured for remote starts, a message will appear “Please Press LOCAL START button to enable Remote Starts”. Pressing the local start button on the panel after remote starts has been enabled insures the safety of the operator, so that no remote user can start the chiller without a local operator’s knowledge. The message will then change to “Remote Starts Permitted until Mode is changed to LOCAL or chiller trips offline”.

During a start sequence the economizer level will establish before the chiller/heat pump loads, to keep from slugging the low stage compressor. The message will appear “PRV RAMP HOLD – BUILDING ECONOMIZER LEVEL”. This will stay illuminated until the level is established.

NAVIGATION**Home**

Used to provide additional Home information.

Economizer

Returns the display to the Economizer Screen.

Capacity Controls

Returns the display to view the Capacity Controls Screen.

Return

Returns the display to the previous screen.

CONDENSER SCREEN

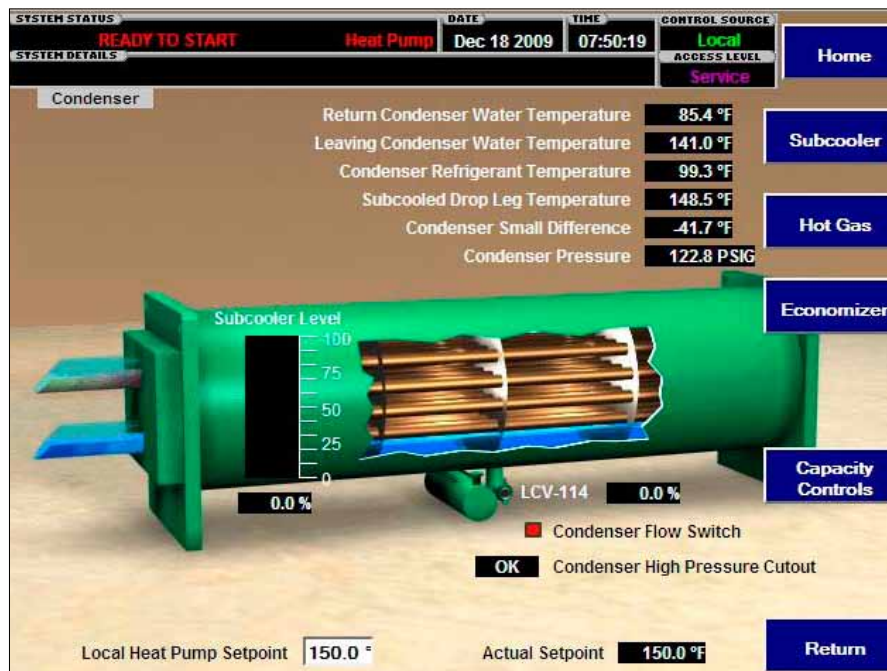

LD15243

FIGURE 33 - CONDENSER SCREEN

OVERVIEW

The condenser screen shows the operational nature of the condensing heat exchanger. The temperatures of the water entering and leaving the condenser are shown. The Condensing pressure and saturation temperature are also shown on this screen. The temperature of the subcooled liquid coming out of the drop leg of the condenser is displayed here. The conditions of the High Pressure Cutout will always be OK under normal operation. If the High Pressure Cutout switch ever shows TRIP, investigate the pressure of the condenser vessel and evaluate the integrity of the switch. This switch is installed per code with no intervening stop valve.

DISPLAY

Return Condenser Water Temperature

Displays the water temperature as it enters the condenser.

Leaving Condenser Water Temperature

Displays the water temperature as it leaves the condenser.

Condenser Pressure

Displays the refrigerant pressure in the condenser.

Condenser Flow Switch

Indicates whether flow is present in the condenser.

PROGRAMMABLE (HEAT PUMP ONLY)

Local Heating Water Setpoint = XX.X

Access Level Required: OPERATOR

Pressing this button will allow the user to change the leaving condenser water setpoint. Press Submit to confirm the new setpoint.

During a start sequence the economizer level will establish before the chiller/heat pump loads, to keep from slugging the low stage compressor. The message will appear "PRV RAMP HOLD – BUILDING ECONOMIZER LEVEL". This will stay illuminated until the level is established.

NAVIGATION

Home

Used to provide additional Home information.

Subcooler

Returns the display to the Subcooler Screen.

Hot Gas

Returns the display to the Hot Gas Screen.

Economizer

Returns the display to the Economizer Screen.

Capacity Controls

Returns the display to view the Capacity Controls Screen.

Return

Returns the display to the previous screen.

SUBCOOLER SCREEN

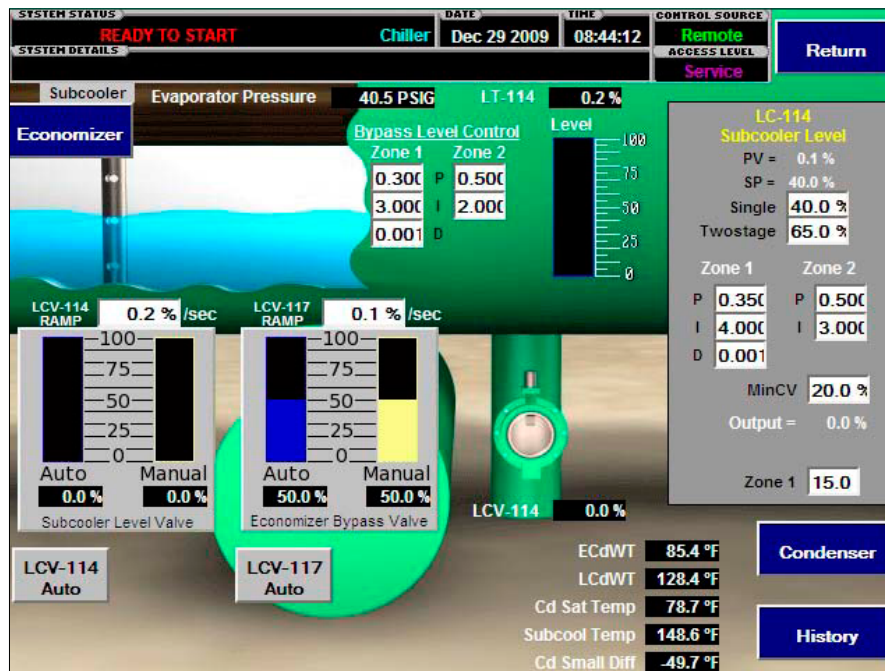

LD15265

FIGURE 34 - SUBCOOLER SCREEN

OVERVIEW

The Subcooler provides a cycle efficiency to the chiller by cooling the high pressure refrigerant before it passes through the high pressure expansion valve.

DISPLAY

Return Condenser Water Temperature

Displays the temperature of the condenser water returning to the condenser.

Leaving Condenser Water Temperature

Displays the temperature of the condenser water returning to the condenser.

Condenser Refrigerant Temperature

Displays the current temperature of the condenser refrigerant.

Subcooler Temperature

Displays the temperature of the refrigerant in the subcooler.

Condenser Small Temperature Difference

Displays the temperature expressed as a differential between the water leaving and the water entering the condenser.

Evaporator Refrigerant Level

(Graphical) Displays the evaporator refrigerant level in percent.

INTERACTIVE

Subcooler Valve Manual / Auto Station

Allows the operator to manually adjust the subcooler valve to the desired setting. Pressing the Auto key allows the operator to adjust the subcooler level valve from 0 – 100% open using the Increase and Decrease keys on the bottom of the display. Pressing the AUTO button when in manual adjustment mode toggles back to automatic control.

PROGRAMMABLE

LC-114 is the subcooler level control box. Parameters include:

(PV) Process Variable – Indicates the process variable value.

(SP single) Subcooler Level Setpoint – Operator uses this entry field to adjust the subcooler level setpoint when running a single stage.

(SP twostage) Subcooler Level Setpoint – Operator uses this entry field to adjust the subcooler level setpoint while running compounded in two-stage mode.

PID – Proportional variable (P), integral variable (I), and derivative variable (D).

- ZONE 1 – Is the steady state control loop gains.
- ZONE 2 – Is the transient and more aggressive control loop gains.
- DB – Deadband that defines Zone 1 and Zone 2. The DB value is the Percentage of the total range that Zone 1 tuning values are used. For example, entering 10% will define a 10% band around the setpoint where the steady state Zone 1 gains will be used.
- SUBCOOLER RAMP RATE in %/sec – When the chiller is powered on, the subcooler valve attempts to fill the subcooler at the designated rate.

- FIFO SAMPLES – Because the refrigerant represents a large fluid mass, constant wave and ripple motion pervades the fluid level measurements. The processor samples the refrigerant level once every 10 milliseconds, then takes the average of this number of readings.
- MIN CV – The subcooler level control valve cannot be allowed to close. The control variable signal is limited to this percentage, to keep the valve from completely closing and the unit from going down on low suction pressure.

NAVIGATION

Return

Returns the display to the previous screen.

Condenser

A detailed view of all condenser parameters, including control of the liquid level functions.

History

This screen provides access to a Time stamped Record of shutdown conditions.

HOT GAS SCREEN

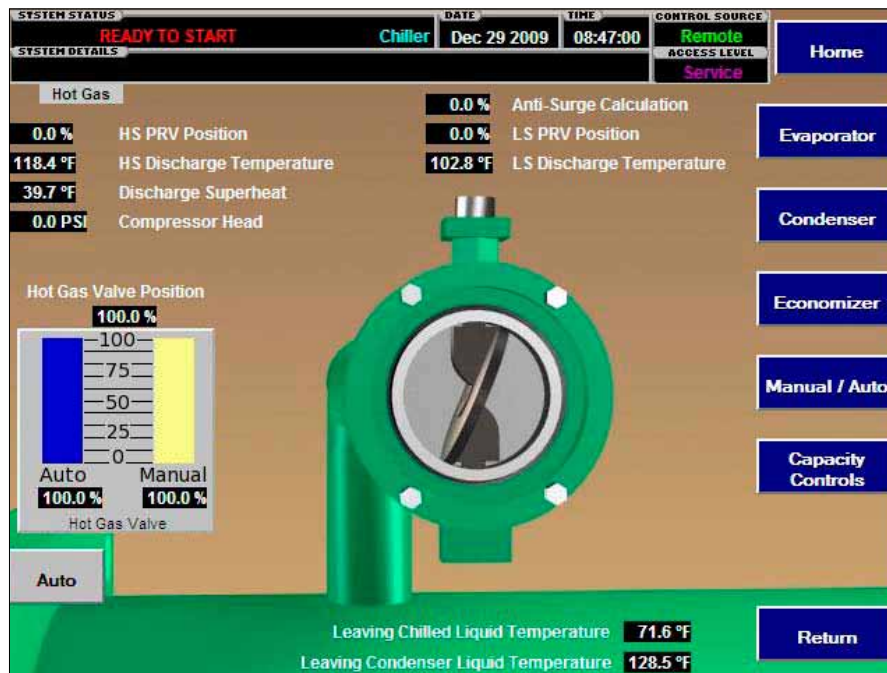

LD15246

FIGURE 35 - HOT GAS SCREEN

OVERVIEW

This screen displays a cutaway view of the Hot Gas Bypass Valve. The setpoints relating to the Hot Gas Bypass Control are maintained on this screen. Related Hot Gas control parameters are displayed for reference. The Hot Gas Valve can be manually controlled from this screen. Through animation, the relative valve position is displayed.

DISPLAY

HS PRV Position

Displays the position of the pre-rotation vanes in percent.

HS Discharge Temperature

Displays the compressor discharge temperature.

Discharge Superheat

Displays the temperature expressed as a differential between the discharge temperature and the condenser saturation temperature.

Compressor Head

Displays the pressure expressed as a differential between the compressor suction and compressor discharge pressures.

Hot Gas Valve Position

Displays the position of the valve in terms of percentage open.

Antisurge Calculation

Is the present minimum Low Stage vane position for the current running conditions.

LS PRV Position

Displays the position of the pre-rotation vanes in percent.

LS Discharge Temperature

Displays the compressor discharge temperature.

Leaving Condenser Liquid Temperature

Displays the temperature of the condenser liquid as the liquid exits the condenser.

Leaving Chilled Liquid Temperature

Displays the temperature of the chilled liquid as the liquid exits the evaporator.

INTERACTIVE**Hot Gas Valve Manual Auto Station**

Allows the operator to manually adjust the position of the hot gas bypass valve.

Pressing the Auto key allows the operator to adjust the hot gas valve position from 0 – 100% open using the Open and Close keys on the bottom of the display.

Pressing the AUTO button while in manual adjustment mode to toggle back to automatic control will only be accepted if the manual setting is within 5% of the automatic setting.

NAVIGATION**Home**

Used to provide additional Home information.

Evaporator

A detailed view of all evaporator parameters, including the programmable Leaving Chilled Liquid Setpoints.

Condenser

A detailed view of all condenser parameters, including control of the liquid level functions.

Economizer

Returns the display to the Economizer Screen.

Capacity Controls

Returns the display to view the Capacity Controls Screen.

Return

Returns the display to the previous screen.

LOW STAGE COMPRESSOR SCREEN

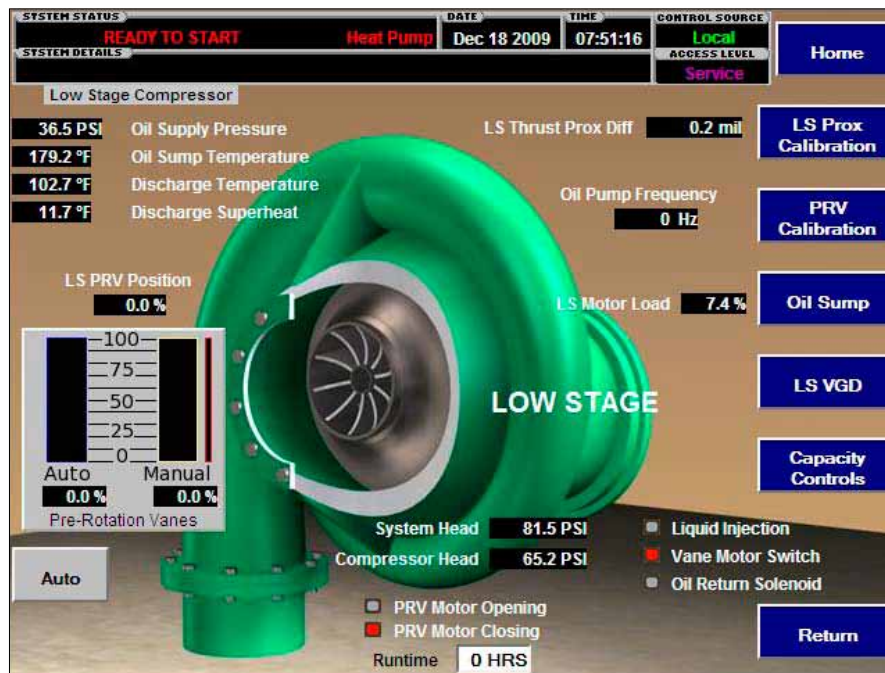

LD15244

FIGURE 36 - LOW STAGE COMPRESSOR SCREEN

OVERVIEW

Displays data about the Low Stage Compressor.

DISPLAY

Oil Supply Pressure

Displays the pressure differential between the high side oil pressure transducer (HOP, located between oil filter output and compressor bearing input) and the low side oil pressure transducer (LOP, located between oil sump and compressor housing). The displayed value includes offset pressure derived from auto-zeroing during the system prelube. The display field will show `__._` when either of the transducers used to calculate oil pressure are out of range. The zero function occurs when the RESET button is pressed, the oil pumps are not running, and there are no system faults or alarms. The offset pressure is the pressure difference between the high oil pressure (HOP) transducer and the low oil pressure (LOP) transducer outputs. During this time, the transducers should be sensing the same pressure. However, due to accuracy tolerances in transducer design, differences may exist in these pressure readings.

To compensate for these differences between transducers and assure differential pressure sensing accuracy, the offset pressure is subtracted algebraically from the oil (differential) pressure value. The offset pressure calculation will not be performed if either transducer is out of range and the offset value will be 0 PSI in this instance.

Oil Sump Temperature

Displays the temperature of the oil in the sump.

Discharge Temperature

Displays the temperature of the refrigerant (vapor) at discharge of the compressor before the refrigerant enters the condenser.

Discharge Superheat

Displays the discharge superheat. This value is calculated by subtracting the condenser saturation temperature (PE-113) from the compressor discharge temperature (TE-112).

LS PRV Position

Displays the Compressors PRV open position percentage.

LS Thrust Prox Diff

Displays the distance between the high-speed thrust collar and the tip of the proximity probe. This measurement takes into account the reference position established at the time of compressor manufacture.

Oil Pump Frequency

Displays operating frequency at which Oil Pump is commanded to run.

LS Motor Load

Displays the motor current as a percentage of the Full Load Amps (FLA) value.

System Head

Displays the chiller head pressure calculated as (condenser pressure – evaporator pressure).

Compressor Head

Displays the Compressors head pressure calculated as condenser pressure minus economizer pressure.

NAVIGATION**Home**

Used to provide additional Home information.

LS Prox Calibration

Returns the display to view the LS Prox Calibration Screen.

PRV Calibration

Access Level Required: OPERATOR

Only available if the chiller is stopped, advances to the PRV Calibration Screen.

Oil Sump

Returns the display to view the Oil Sump Screen.

LS VGD

Returns the display to view the LS VGD Screen.

Capacity Controls

Returns the display to view the Capacity Controls Screen.

Return

Returns the display to the previous screen.

LS PROXIMITOR CALIBRATION (LOW AND HIGH STAGES) SCREEN



LD15244

FIGURE 37 - LS PROXIMITOR CALIBRATION (LOW AND HIGH STAGES) SCREEN

OVERVIEW

At the factory, or when a compressor is replaced on a chiller, the proximity probes must be calibrated. Insure that there is oil in the oil sumps during this procedure. Navigate to this screen, and press [START CAL] to start the calibration procedure. The oil pump will produce rated pressure, and the proximity reading will be taken. This will be the reference point. Press [ENTER REF] to ACCEPT the calibration data. Press [END CAL] to end the calibration procedure.

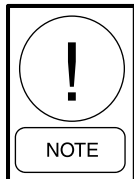

If the difference between the actual reading and this reference exceed the alarm and trip values, and a proximitor TRIP is produced, the compressor should be evaluated for thrust bearing damage.

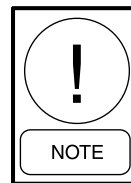

Any time the Quantum™ LX controller application program is updated, the axial proximitor reference values, recorded on the panel door from commissioning, must be entered into these screens.



If a compressor proximity shutdown is generated, it will be necessary to contact the YORK factory Technical Support to reset the panel to insure there is not damage to the compressor thrust bearing.

DISPLAY

High Speed Thrust Bearing Proximity Position
 N/A

High Speed Thrust Bearing Proximity Reference
 N/A

Oil Supply Pressure

Displays available oil pressure to the compressor.

Proximitor Forward

Warning and Shutdown limits.

Proximitor Reverse

Warning and Shutdown limits.

NAVIGATION

Home

Used to provide additional Home information.

Low Stage Compressor

This screen displays data about the Low Stage Compressor.

HS Prox Calibration

This screen Displays data about the HS Prox Calibration.

History

This screen provides access to a Time stamped Record of shutdown conditions.

PRV CALIBRATION SCREEN

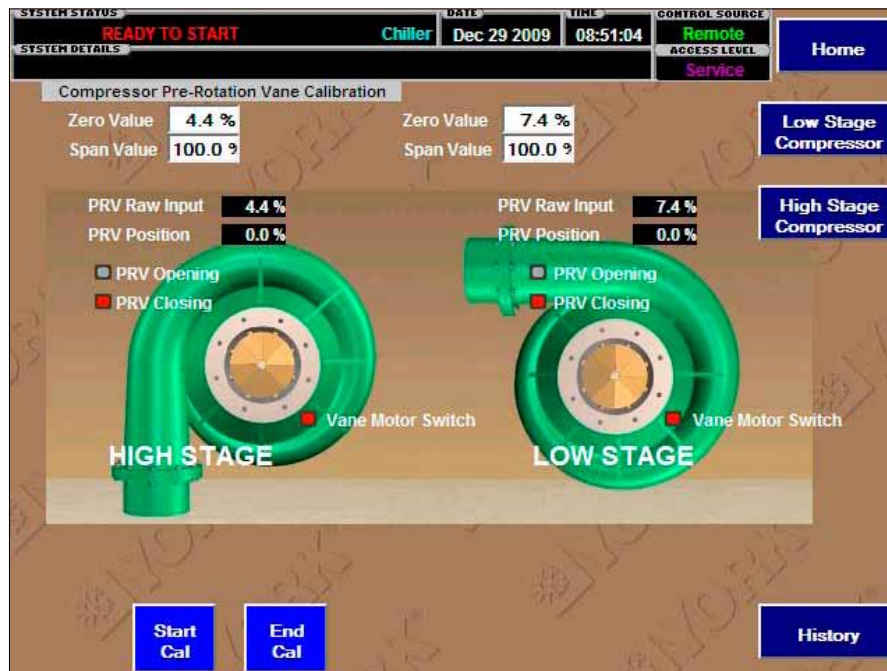

LD15266

FIGURE 38 - PRV CALIBRATION SCREEN

OVERVIEW

If a PRV position potentiometer must be replaced in the field, the position of the potentiometer relative to the actual vane position is critical.

1. The PRV POT assembly, shown below, should first be assembled to the compressor. Next navigate to the PRV Calibration screen on the panel.
2. Loosen the Allen Set Screw on the PRV POT coupling connected to the COMPRESSOR side of the coupling. This will allow you to turn the coupling and move the potentiometer position.
3. Adjust the PRV POT position until the PRV RAW INPUT percentage reads between 10% and 20%.
4. After this reading is obtained, tighten the Allen Set Screw on the coupling, and proceed to the calibration procedure as described below.

DISPLAY

PRV Raw Input

Displays the vane position signal read directly off the potentiometer.

PRV Position

Displays the real-time position of the vanes.

PRV Opening / Closing

Displays the status of the vane actuator.

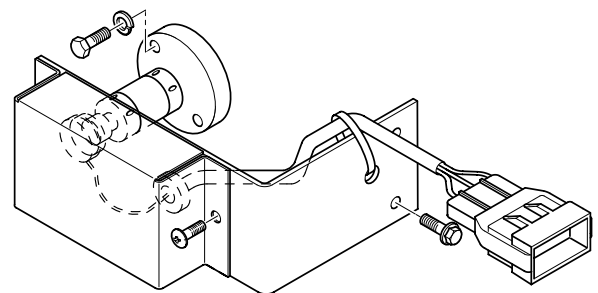

LD14879a

FIGURE 39 - PRV POSITION SENSOR

Vane Motor Switch (LED)

Illuminates when the Vane Motor Switch contacts are closed (provided by PRV Closed Limit Switch ZS-100A).

Zero Value Setpoint

Access Level Required: OPERATOR

For manual calibration of the PRV; corresponds to the raw PRV potentiometer input with the vanes fully closed.

Span Value

Access Level Required: OPERATOR

For manual calibration of the PRV; corresponds to the raw PRV potentiometer input with the vanes fully open.

INTERACTIVE**[START CAL]**

Selecting this button initiates a vane position calibration algorithm.

[END CAL]

Selecting this button accepts the automated vane calibration or cancels the calibration procedure.

When START CALIBRATION is selected, a message “Vane motor stroking please wait” appears.

Press [END CAL] to accept calibration.

NAVIGATION**Home**

Used to provide additional Home information.

Low Stage Compressor

This screen displays data about the Low Stage Compressor.

High Stage Compressor

This screen Displays data about the High Stage Compressor.

History

This screen provides access to a Time stamped Record of shutdown conditions.

OIL SUMP (UNIFIED SUMP PRESSURE) SCREEN

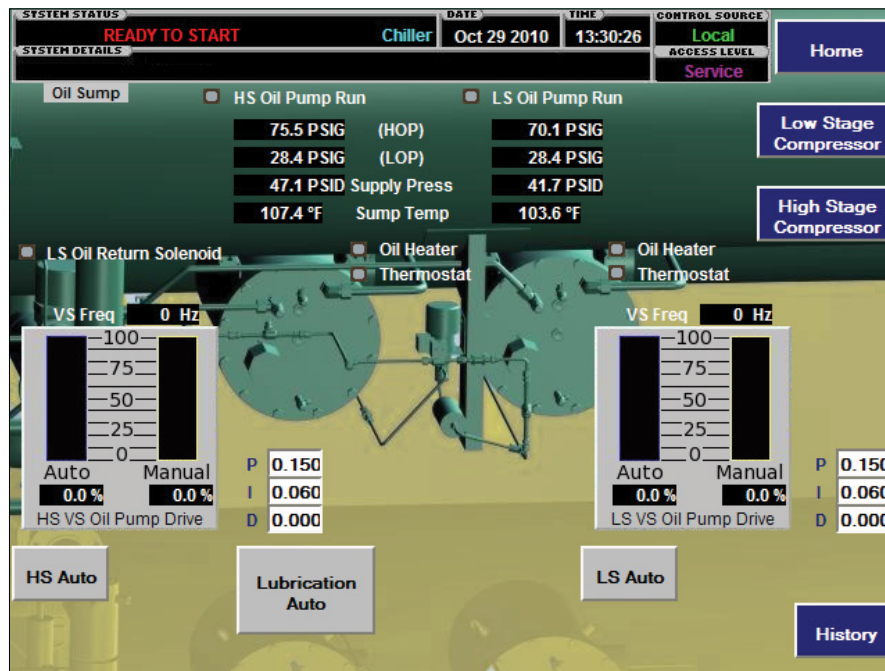

LD15281

FIGURE 40 - OIL SUMP (UNIFIED SUMP PRESSURE) SCREEN

OVERVIEW

This screen displays a close-up of the chiller oil sump and provides all the necessary setpoints for maintaining the Variable Speed Oil Pump (VSOP). In addition, this screen allows manual control of the frequency command sent to the VSOP.

DISPLAY

HS Oil Pump Run

Indicates the run status of the Oil Pump.

LS Oil Pump Run

Indicates the run status of the Oil Pump.

Oil Heater

Indicates the operational status of the oil heater.

LS Oil Return Solenoid

N/A

PROGRAMMABLE

HS Auto/LS Auto

Access Level Required: SERVICE

Manual automatic stations allow analog control of valves and vanes. The analog process control system is based on a 0 – 100% range. The automatic control system drives the valve or vanes with a percentage of drive signal. The operator interface allows an experienced technician to take manual control of a device. Pressing the button marked AUTO toggles the device into a manual control state. The button turns red and the word MANUAL appears. Pressing MANUAL will toggle the device into an automatic state. While in manual control, the OPEN (INCREASE) or CLOSE (DECREASE) buttons may be used to manipulate the valve or vane. The bar graph on the right shows the actual position of the valve or vane. The automatic bar graph shows where the automatic control system wants the device to be.

P

This key allows the service technician to set the proportional gain of the primary and economizer oil pumps.

I

This key allows the allows the service technician to set the integral gain of the primary and economizer oil pumps.

D

This key allows the service technician to set the derivative gain of the primary and economizer oil pumps.

NAVIGATION**Home**

Used to provide additional Home information.

Low Stage Compressor

This screen displays data about the Low Stage Compressor.

High Stage Compressor

This screen Displays data about the High Stage Compressor.

History

This screen provides access to a Time stamped Record of shutdown conditions.

OIL SUMP (ICE THERMAL STORAGE) SCREEN

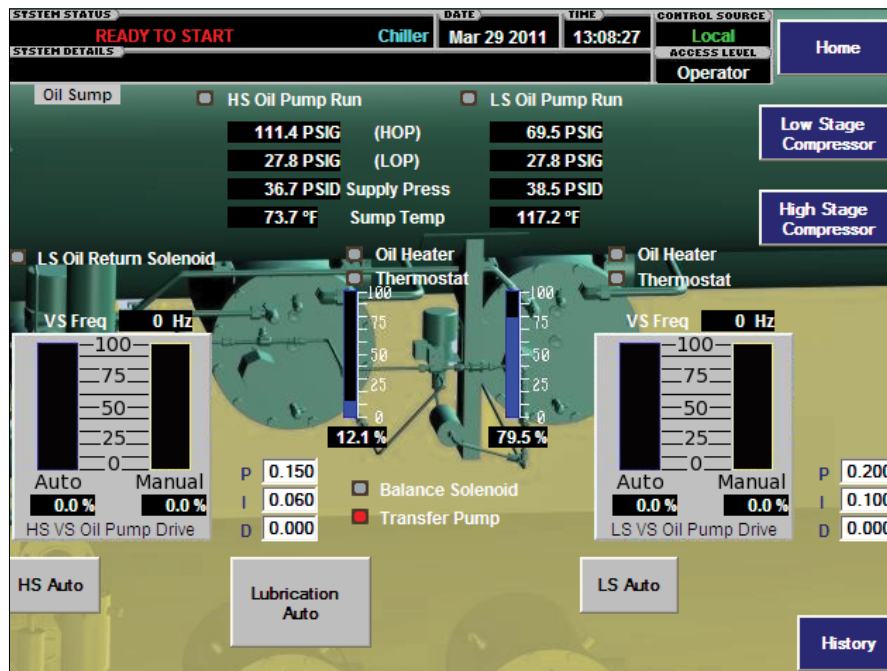

LD15267

FIGURE 41 - OIL SUMP (ICE THERMAL STORAGE) SCREEN

OVERVIEW

This screen displays a close-up of the chiller oil sump and provides all the necessary setpoints for maintaining the Variable Speed Oil Pump (VSOP). In addition, this screen allows manual control of the frequency command sent to the VSOP.

DISPLAY

Oil Sump Temperature

Displays the oil sump temperature.

Oil Sump Pressure (Hop)/(Lop)

Displays the pressure at the high and low pressure sides of the oil sump.

Oil Supply Pressure

Displays the oil supply differential pressure (pump – sump).

Oil Pump Frequency

Displays the variable-speed oil pump drive frequency.

Oil Pump Run

Indicates the operational status of the oil pump.

Oil Return Solenoid

Indicates the status of the oil return solenoid.

Oil Heater

Indicates the operational status of the oil heater.

INTERACTIVE

Auto / Manual

Allows *SERVICE MODE* to manually adjust the oil pump drive speed.

Selecting Auto causes two additional screen tabs to appear. Increases the drive frequency and Decreases the drive frequency. Pressing the MANUAL while in manual control mode toggles back to automatic control.

This Manual / Auto station is not available below Service Level access.

Lubrication Auto/Lubrication Lock On

Toggles the oil pumps off/on in standby mode, producing rated oil pressure with the drives in automatic. This can be used for testing the oil lubrication circuit. This button can also be used when jogging the motors for direction.

PROGRAMMABLE**Access Level Required: SERVICE****Oil Supply Pressure Controller**

Includes proportional gain (P), integral gain (I), and differential gain (D) accessible by SERVICE level.

On Non-Unified Oil Sumps the oil transfer settings are available to the SERVICE level.

Oil Sump levels are indicated in the center of the screen. If the oil levels associated with each level alarm shown in the bottom center of the screen and alarm will be logged in the alarm history.

The purposed of the oil transfer system is to maintain equal levels of oil in each sump. If the oil levels are more than 15% different, then a transfer is initiated automatically. If the oil in the high stage sump is higher then the balance transfer solenoid is opened until the levels are equal or the LS High oil level STOP setpoint is reached. If the oil in the Low Stage is higher then the oil transfer pump is started until the levels are equal, or until the LS Low oil level setpoint is reached, or the HS High oil level setpoint is reached.

Oil Return System Operation

Centrifugal chillers will lose a small amount of oil into the refrigeration system. Over time, this oil will accu-

multate in the evaporator refrigerant charge. This oil can have a negative impact on heat transfer for modern tube surfaces. It is necessary to have an oil return system in place to return the lost oil back to the compressor oil reservoir.

Eductor Block Low Stage Oil Return

The compound YK oil return system uses an eductor block to return oil to the low stage compressor oil reservoir. The eductor block uses high-pressure refrigerant gas through a venturi nozzle eductor as motive force to pull oil rich refrigerant liquid from the evaporator and into to the low stage oil reservoir. Over time, oil lost from both compressors would accumulate in the low stage compressor reservoir.

The Oil Return Eductor draws oil from the evaporator and returns it to the Low Stage Sump Pressure. Oil could also have been lost from the High Stage Oil Sump.

High Stage Oil Return

A means to return oil to the High Stage Oil Sump is provided by a small pump. The pump activates when the High Stage Oil Sump is 15% below the Low Stage, with the provision that the Low stage must not be near empty alarm.

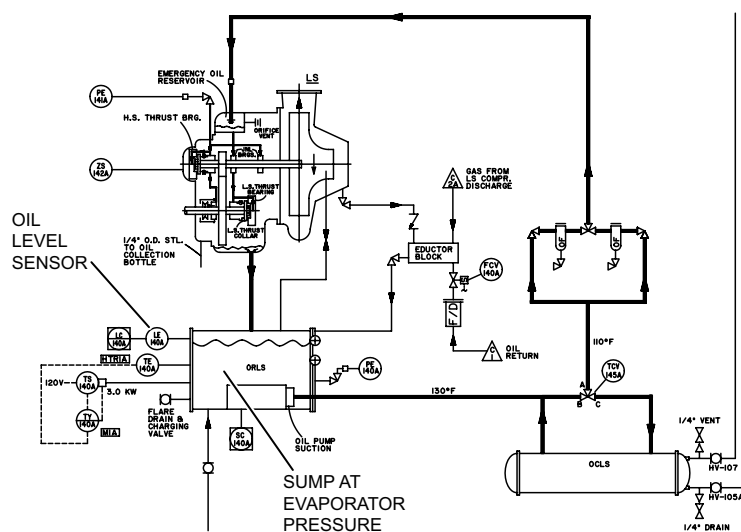
**FIGURE 42 - LOW STAGE OIL RETURN EDUCTOR**

LD15293

An oil level control system is provided to return oil to the higher-pressure high stage oil reservoir. This system consists of a small oil pump piped between the two oil reservoirs and individual level transmitters on each reservoir. The control system monitors the level in each reservoir, and turns the oil transfer pump on when the level in the high stage drops approximately an inch below that of the low stage. If the oil level in the low stage oil reservoir drops 1 inch below the level in the high stage, oil is bled from the supply line to the high stage compressor to the low stage reservoir. A solenoid valve controls this. Low and high oil level alarms are programmed for each reservoir, when the levels extend beyond the sight ports. After servicing the compressor oil, each reservoir should be filled to the sight glass. When adding oil during operation, the oil may be added into the low stage reservoir. The transfer pump will move the oil to the high stage reservoir as needed.

Compressor PRV/suction plenum oil drain: A small connection in the PRV area of each compressor drains a small amount of oil that may collect there. Each compressor is vented to its respective oil reservoir. The low stage compressor drains this oil through the main educator block. The high stage compressor has a separate oil

educator block to return the oil to the high stage reservoir. Refer to the oil flow diagrams.

CAUTION: Use only the approved York “K” type polyolester oil with R-134a. Do not use mineral oils.

Condensate Management System

The Low Stage Primary CYK chiller with separate oil sump pressures requires additional valves and controls to manage refrigerant condensate. When the Low Stage Compressor runs alone, the High Stage Compressor is at discharge pressure. The tendency is that a large heat sink body like the High Stage Compressor is a natural place for refrigerant to condense. Often times the plant room is cooler than the tower water and increases the proclivity for refrigerant to gather in the High Stage Compressor.

This situation is mitigated by additional valves not found on a CYK Heat Pump or Radiator cooled unit, since their oil sumps operate both at suction pressure. These additional valves isolate the High Stage Oil Sump from the rest of the system and prevent refrigerant condensate from the High Stage Compressor from migrating down to the sump.

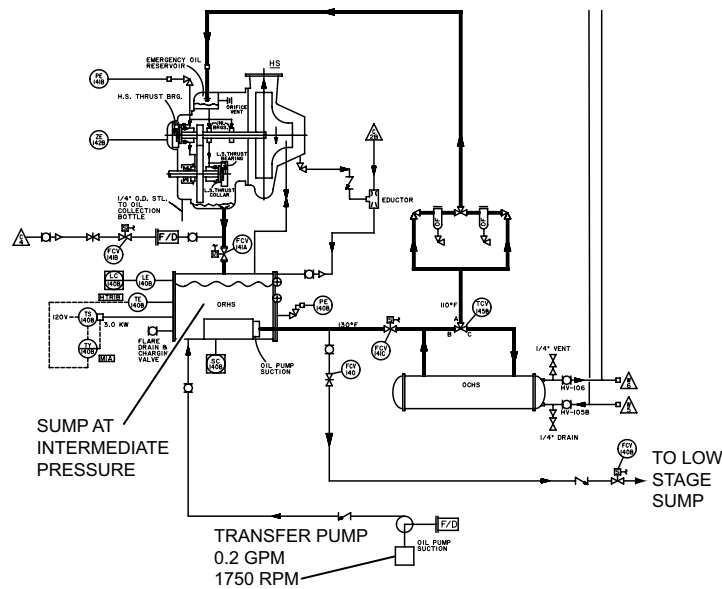

FIGURE 43 - HIGH STAGE OIL RETURN EDUCTOR

LD15294a

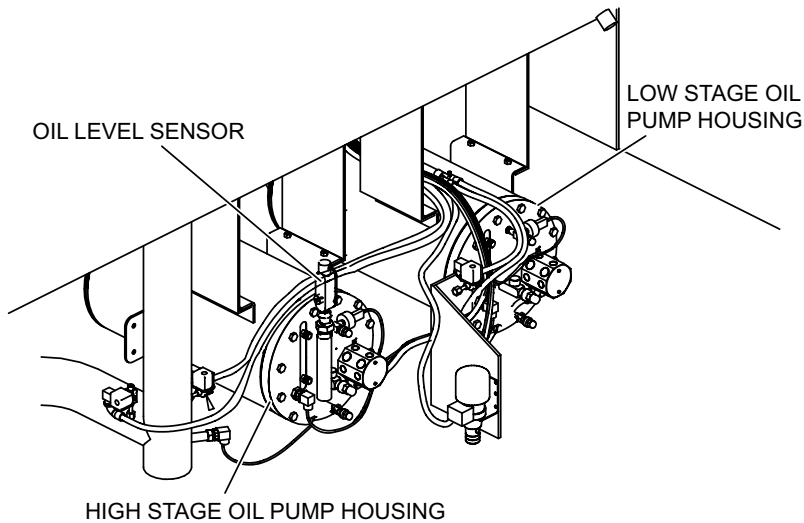

FIGURE 44 - OIL LEVEL SENSOR

LD15295

When the CYK chiller runs in single-stage operation, valve FCV-141A (Drain Block) stops refrigerant gathering in the gearbox cavity from going down the oil drain line. Valve FCV-141B (Scavenge) allows this condensed liquid to be returned to the evaporator. Valve FCV-141C (Pump Isolation Valve) closes and prevents oil from siphoning out of the sump and filling the gearbox with oil.

When the chiller runs in two-stage operation, the valve FCV-141A (Drain Block) opens to allow oil to return to the sump. Valve FCV-141B (Scavenge) closes. Valve FCV-141C (Pump Isolation Valve) opens to allow oil to circulate through the lube system.

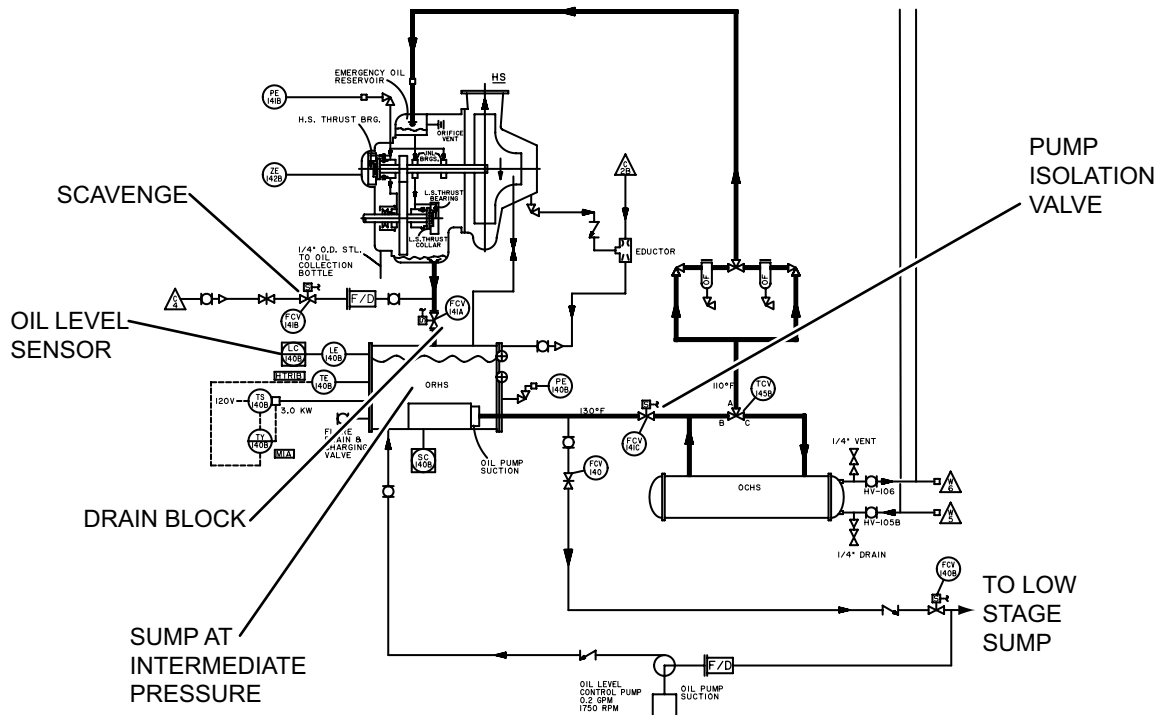
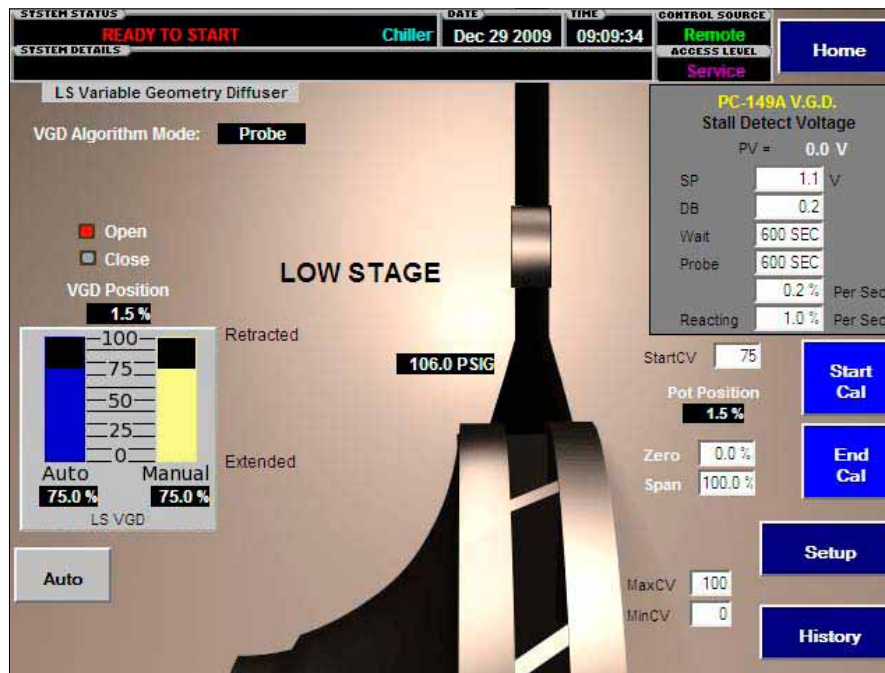

FIGURE 45 - HIGH STAGE OIL SUMP

LD15294a

LS VARIABLE GEOMETRY DIFFUSER SCREEN



LD15256

FIGURE 46 - LS VARIABLE GEOMETRY DIFFUSER SCREEN

OVERVIEW

The Variable Geometry Diffuser (VGD), provides acoustic attenuation of the compressor noise. The VGD ring extends into the discharge to attenuate stall noise by straightening the gas flow, and retracts when attenuation is not required.

A standard manual-auto station is provided to take control of the VGD. The reaction ramp will be set to Manual when transferring to Automatic operation.

The Variable Geometry Diffuser operates when the chiller is running. It has three modes of operation, with a manual override feature:

1. PROBE
2. WAIT
3. REACT

The VGD transducer located in the compressor discharge volute, sends a variable frequency signal representing the acoustic noise component in the compressor, to the VGD Stall Detector board. The VGD Stall Detector board detects the acoustic signal and provides a 0 to 5 vdc signal (PV) to the microboard. This Stall Detector Voltage is compared to the Stall Detector Voltage setpoint (SP) to determine the operating state of the VGD.

The voltage setpoint (SP) provides the limitation of stall noise from the compressor. The deadband setpoint (DB) will allow some area around the setpoint (SP) where the VGD won't move constantly.

PROBING takes place when the stall voltage drops below the setpoint (SP) minus the dead band (DB). The WAIT period is a soak hold period in between PROBE pulses when the VGD is being retracted/probing for noise. The PROBE time and rate, control how much the VGD retracts when probing (opening/retracting) for noise. The Probing state will continue until the stall voltage increases to within the setpoint (SP) – deadband (DB) range, or until the VGD is fully retracted/open.

The REACT mode occurs if at any time the PV noise voltage rises above the setpoint (SP) + deadband (DB). The REACTING ramp rate (%/sec) Closes/Extends the VGD at the programmed rate until the noise voltage level (PV is within the setpoint (SP) +/- deadband (DB) range.

VGD CALIBRATION

The VGD must be calibrated before it is used. During the calibration process, the feedback potentiometer is calibrated such that 100.0% open is when the VGD actuator is fully retracted, and 0.0% open is when the VGD actuator is fully extended. Pressing START CAL while the machine is off starts extending (closes) the VGD to its full limit (Zero value). “Calibration In Process” is displayed on the VGD screen. When the potentiometer input stops moving the VGD retracts (opens) to its full limit (Span value). The Zero and Span are retained in memory during the calibration process so that the VGD can be controlled linearly throughout its range of travel. When “Calibration In Process” is no longer displayed on the VGD screen, “Pressing END CAL will end the calibration procedure and “load” the ZERO and SPAN values retained by memory during the calibration process, and are shown in the Zero and Span fields on the VGD screen.

The potentiometer raw input is shown in the Pot Position field on the display. The VGD Position shown on the display is the results of the calibration process. Note that Pot Position (raw potentiometer value) and VGD position value will not be the same values. The scaled position of the VGD is calculated as follows:

$$\text{VGDPPosition} = (\text{Pot_Value} - \text{VGDZeroValue}) / ((\text{VGDSPANValue} - \text{VGDZeroValue}) / 100).$$

At the end of the calibration procedure, the VGD should return to normal operation. If the potentiometer should go out of range, an alarm indicating that the potentiometer is out of range is displayed.

VGD OUTPUTS/POSITIONING

The VGD outputs shown on the display as OPEN and CLOSE drive the VGD actuator until the VGD Position achieves the target value displayed in the AUTO/MANUAL fields.

To insure uniform operation on startup, a pre-set startup setting (StartCV) is given to the VGD position controller, and positions the VGD to this value on unit shutdown, ready for the next unit start-up. The startup point (StartCV) is determined during commissioning, but is typically within the 70 to 90% range.

The maximum and minimum travel of the VGD ring is limited by the MaxCV and MinCV limit settings. The values of these settings should be set at MaxCV = 100, MinCV = 0.

MANUAL/AUTO OPERATION

When in manual override the manual-automatic station takes control of the reaction ramp and overrides the VGD target position. The positioner then follows the manual controlled value.

DISPLAY ONLY

VGD Algorithm Mode

Displays the state of operation for the VGD.

VGD Motor Opening (LED)

Illuminates when the Compressor VGD is in the process of opening (retracting).

VGD Motor Closing (LED)

Illuminates when the Compressor VGD is in the process of closing (extending).

VGD Position

Displays the Compressor VGD position.

PROGRAMMABLE

Auto

Access Level Required: OPERATOR

Refer to *Figure 26 on page 55* for operational description.

NAVIGATION

Home

Used to provide additional Home information.

Setup

This screen provides a single location to program the most common system setpoints. It is also the gateway to many of the general system setup parameters such as I/O configuration, Communications Setup, Software Maintenance, Trending, and diagnostics.

History

This screen provides access to a Time stamped Record of shutdown conditions.

HIGH STAGE COMPRESSOR SCREEN

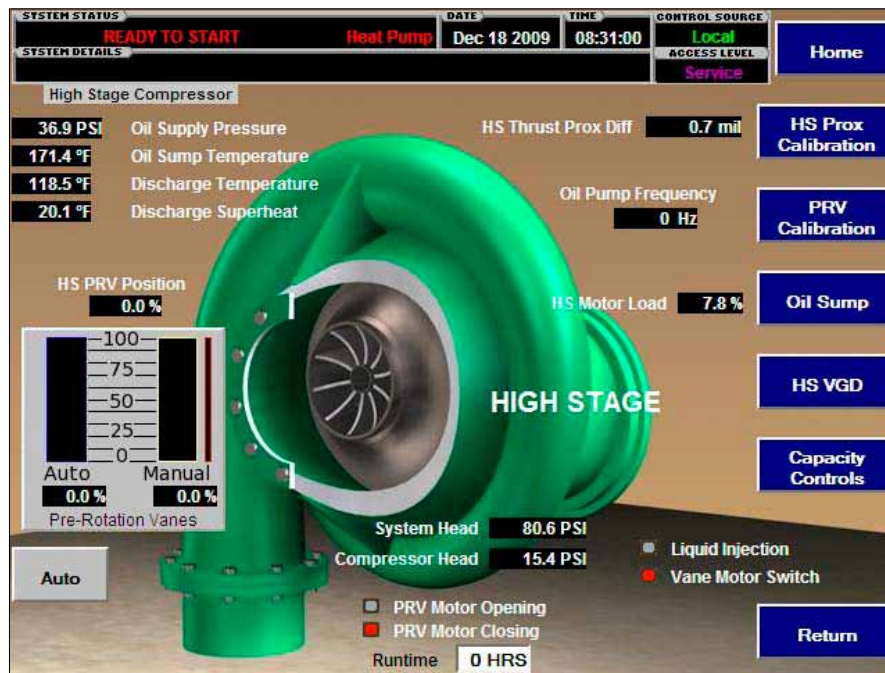

LD15245

FIGURE 47 - HIGH STAGE COMPRESSOR SCREEN

OVERVIEW

Displays data about the High Stage Compressor.

DISPLAY

Oil Supply Pressure

Displays the oil supply pressure.

Oil Sump Temperature

Displays the oil sump temperature.

Discharge Temperature

Displays the temperature of the refrigerant gas at the compressor outlet.

Discharge Superheat

Displays the temperature expressed as the differential between the discharge temperature and the condenser saturation temperature.

System Head

Displays the chiller head pressure calculated as (condenser pressure – evaporator pressure).

Compressor Head

Displays the head pressure expressed as a differential between the compressor suction and discharge.

HS Thrust Prox Diff

Displays the distance between the high-speed thrust collar and the tip of the proximity probe. This measurement takes into account the reference position established at the time of compressor manufacture.

Oil Pump Frequency

Displays the operating frequency of the variable-speed oil pump drive.

HS Motor Load

Displays the position.

HS PRV Position

Displays the position of the pre-rotation vanes in percent.

Vane Motor Switch

Indicates the status of the vane motor switch.

Oil Return Solenoid

Displays the status of the oil return solenoid to the Low Stage Compressor.

INTERACTIVE**Pre-Rotation Vane Manual / Auto Station**

Access Level Required: OPERATOR

Operator may manually adjust the position of the pre-rotation vanes.

Pressing the Auto button allows the operator to adjust the pre-rotation vane setting from.

0 – 100% open using the OPEN and CLOSE keys on the bottom of the display.

Pressing the MANUAL button while in manual control mode toggles back to automatic control.

NAVIGATION**Home**

Used to provide additional Home information.

HS Prox Calibration

Returns the display to view the HS Prox Calibration Screen.

PRV Calibration

Access Level Required: OPERATOR

Only available if the chiller is stopped, advances to the PRV Calibration Screen.

Oil Sump

Returns the display to view the Oil Sump Screen.

HS VGD

Returns the display to view the HS VGD Screen.

Capacity Controls

Returns the display to view the Capacity Controls Screen.

Return

Returns the display to the previous screen.

HS PROXIMITOR CALIBRATION SCREEN



LD15252

FIGURE 48 - HS PROXIMITY CALIBRATION SCREEN

OVERVIEW

This screen displays a cutaway view of the chiller compressor, revealing the proximity probe sensor and provides the capability of calibrating the proximity probe sensor.

DISPLAY ONLY

Thrust Prox Probe Position

Displays the distance between the high-speed thrust collar and the proximitor probe that is used to measure the position. A positive number is in the forward direction, a negative number is in the reverse direction.

Thrust Prox Differential

Displays the difference between the proximitor probe position and the proximitor reference position.

Compressor Oil Pressure

Displays the primary compressor oil pressure.

Calibration Active (LED)

Illuminates when the primary compressor is currently performing a proximitor calibration.

PROGRAMMABLE

Thrust Prox Reference

Access Level Required: SERVICE

This key allows the technician to define the primary compressor proximitor probe offset reference position.

Primary Prox Calibration

Access Level Required: SERVICE

Start

This button activates a primary compressor proximitor probe calibration procedure to begin, which starts the compressor oil pump.

Accept

This button allows the technician to accept the position of the primary compressor proximitor probe.

End

This button cancels the request for a primary compressor proximitor calibration procedure.

Reset Tripped Prox

Access Level Required: FACTORY

This button allows the technician to reset a tripped primary compressor proximitor probe under the direction from the Factory Technical Support Team.

NAVIGATION

Home

Used to provide additional Home information.

Low Stage Compressor

This screen displays data about the Low Stage Compressor.

HS Prox Calibration

This screen Displays data about the HS Prox Calibration.

History

This screen provides access to a Time stamped Record of shutdown conditions.

LIQUID COOLED SOLID STATE STARTER (OPTIONAL)

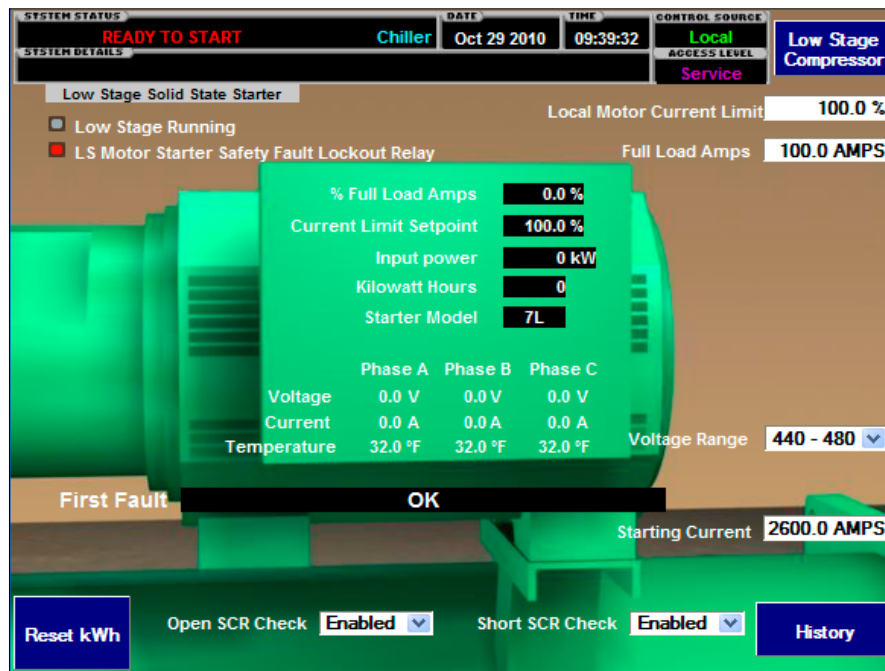

LD15325

FIGURE 49 - LIQUID COOLED SOLID STATE STARTER (OPTIONAL)

OVERVIEW

The YORK model LCSSS is an option for the CYK in low voltage applications. The LCSSS is factory mounted and integrated onto the Quantum™ LX industrial control center. The starter is configured at the factory. The LCSSS data is viewable from this screen. Refer to the LCSSS literature FORM 160.00-O2 for operation of this equipment. Please recall that the CYK does not support cycling shutdowns.

The LCSSS contains a single Logic/Trigger printed circuit board. This board performs the following functions:

- Generates the SCR trigger pulses.
- Receives start/stop commands from the Quantum™ LX.
- Transmits status and fault data to the Quantum™ LX.
- Generates all LCSSS initiated Safety shutdowns.

The Logic/Trigger Board is powered by +24VDC from the Quantum™ LX industrial control center Power Supply. The Quantum™ LX Motherboard COM 3 communicates with this board via a 19.2K baud Mod-

bus ASCII serial data communications link. The **STOP** relay contacts on the Logic/Trigger Board assure a positive shutdown on all LCSSS initiated shutdowns.

When the temperature sensors detect a heatsink temperature above 108°F, the circulation pump will run until the temperature drops below this threshold. The high heatsink temperature is handled as a temperature-based anti-recycle. When the temperature returns to normal, the LCSSS will be reset automatically by the Quantum™ LX, and the System Status “**READY TO START**” will be displayed.

DISPLAY ONLY

Motor Run (LED)

Indicates when the CYK Control Center is commanding the motor to run.

Motor Full Voltage Run Interlock (LED)

Indicates when the LCSSS has confirmed motor operation.

Starter OK (LED)

Indicates when the LCSSS has confirmed a no fault condition.

Motor Current % Full Load Amps

Displays the motor current as a percentage of Job Full Load Amps setpoint.

Input Power

Displays the kilowatts measured by and transmitted from the starter.

Voltage – Phase A, B, C

Displays the 3-phase input line voltage as measured by and transmitted from the starter.

Current – Phase A, B, C

Displays the 3-phase motor current as measured by and transmitted from the starter.

Starter Model

Displays the starter model number as transmitted from the starter.

INTERACTIVE

When the Logic Board detects an **Overload** condition, Relay K1 contacts open and the **Overload** LED illuminates. A Motor Starter Fault is displayed in the System Details. The contacts remain open and the LED remains illuminated until manually reset at the Quantum™ LX.

The Low Stage SSS is configured as Modbus node 1, and the High Stage SSS is configured as Modbus node 2. The Quantum™ LX Com 3 port is used as the Modbus Master to communicate with the starters.

PROGRAMMABLE**Local Motor Current Limit**

Access Level Required: OPERATOR

Allows the user to specify the maximum allowed motor current (as percentage of FLA). When the motor current reaches this value, the Capacity Controls will not be permitted to load further. If the motor rises above this value, the Capacity Controls will reduce the current to this value.

Full Load Amps

Access Level Required: SERVICE

Defines the maximum amps at which the motor can operate. This value is viewable when logged in at Operator or View access level.

TABLE 9 - FULL LOAD AMPS

LCSSS MODEL	PERMISSIBLE FLA
7L-46, 58 and 50	35 to 260 Amps
14L-17, 28, 46, 58 and 50	65 to 510 Amps
26L-17, 28, 46, 58 and 50	125 to 850 Amps
33L-17, 28, 46 and 50	215 to 1050 Amps

Start Current - The Logic/Trigger Board will limit in-rush motor current to this value during starting. The programmed value is sent to the Logic/Trigger Board over the serial communications link. This setpoint should be programmed to (0.45 x motor Delta Locked Rotor Amps). Each model starter has a permissible range over which this setpoint can be programmed as follows:

TABLE 10 - START CURRENT

LCSSS MODEL	PERMISSIBLE START CURRENT RANGE
7L-46, 58 and 50	310 to 700 Amps
14L-17, 28, 46, 58 and 50	620 to 1400 Amps
26L-17, 28, 46, 58 and 50	1150 to 2600 Amps
33L-17, 28, 46 and 50	1460 to 3300 Amps

Voltage Range

Access Level Required: SERVICE

Allows the user to select specific line voltage range for voltage checking. When not disabled, this line voltage range is used to determine a low line and high line voltage threshold for initiating a shutdown.

To assure the chiller is not permitted to run for extended periods with the supply line voltage outside of acceptable limits, the Logic/Trigger Board compares the actual 3-phase line voltage to the thresholds established with the Supply Line Voltage Range setpoint. Each supply voltage application has an allowable upper and lower limit. If the supply voltage goes above or below these limits continuously for 20 seconds, the logic trigger Board initiates a Cycling shutdown and displays “LCSSS - HIGH SUPPLY LINE VOLTAGE” or “LCSSS - LOW SUPPLY LINE VOLTAGE” as appropriate.

Open SCR (Enabled/Disabled)

Access Level Required: SERVICE

Allows the user to enable or disable the Solid State Starter Open SCR safety detection. This must never be disabled unless under advisement of the YORK Factory.

Open SCR (Enabled/Disabled)

Access Level Required: SERVICE

Allows the user to enable or disable the Solid State Starter Open SCR safety detection. This must never be disabled unless under advisement of the YORK Factory.

kWH Reset

Access Level Required: SERVICE

Allows the user to reset the cumulative Kilowatt Hours.

NAVIGATION

Low Stage Compressor

This screen displays data about the Low Stage Compressor.

History

This screen provides access to a Time stamped Record of shutdown conditions.

CAPACITY CONTROLS SCREEN

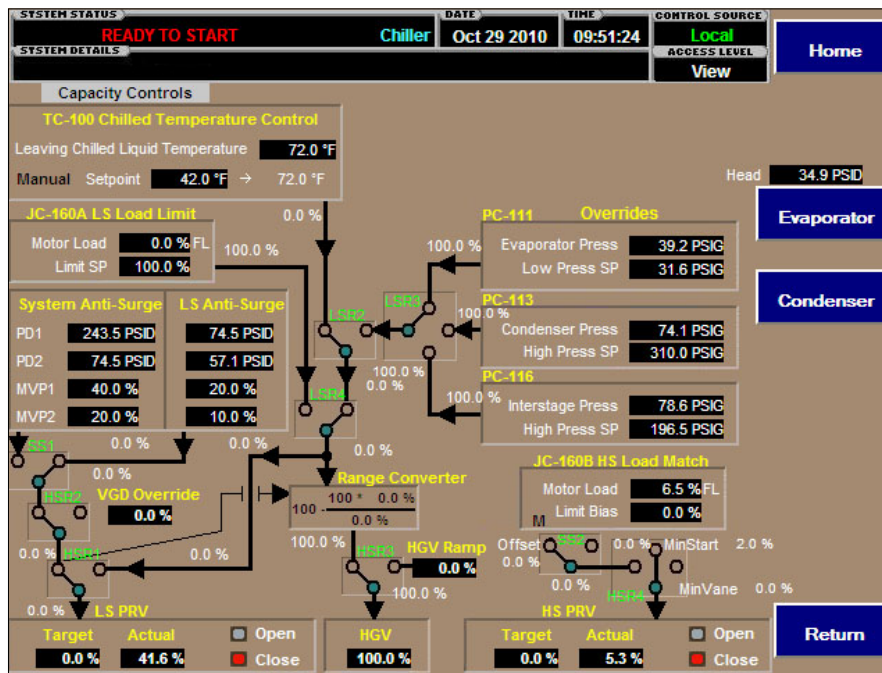

LD15257

FIGURE 50 - CHILLER MODE

CHILLER MODE

The Capacity Controls Screen schematically illustrates the logical operations of chiller capacity control. Sensor readings are linked with setpoint values and compared. PID loops, depicted in each box, pass signals through high or low-pass relay (HSR/LSR) junctions. The relay makes a simple comparison of two signals and passes the higher or lower of the two depending on whether the relay is high or low pass.

HEAT PUMP MODE

The CYK machine has the ability to control itself as a CHILLER or a HEAT PUMP. In Chiller mode, the Leaving Water temperature from the evaporator heat exchanger is the process signal. In Heat Pump mode, the Leaving Water temperature from the condenser heat exchanger is the process signal. The CYK control system will adjust the vanes and hot gas valve to attempt to generate the desired process temperature.

OVERRIDES**Evaporator Pressure**

Displays the current evaporator pressure.

Low Pressure Setpoint

Displays the system low evaporator pressure setpoint, at which the chiller will be unloaded if the evaporator pressure goes below this threshold.

Condenser Pressure

Displays the current condenser pressure.

High Pressure Setpoint

Displays the system high condenser pressure setpoint, at which the chiller will be unloaded if the condenser pressure goes above this threshold.

Interstage Pressure

Displays the current interstage pressure.

Interstage High Pressure Setpoint

Displays the system high condenser pressure setpoint, at which the chiller will be unloaded if the condenser pressure goes above this threshold.

Motor Load

Displays the current motor load in percentage.

Load Limit

Displays the motor load limit setpoint.

HGV Ramp

Displays the hot gas valve ramp rate in percent.

HGV

Displays the current hot gas valve position from opened to closed in percent.

PRV Actual

Displays the actual current position of the pre-rotation vanes from opened to closed in percent.

PRV Target

Displays the control system intended position of the pre-rotation vanes.

Refer to the table of contents for the explanation of the operation of the Capacity Controls System.

NAVIGATION

Home

Used to provide additional Home information.

Evaporator

A detailed view of all evaporator parameters, including the programmable Leaving Chilled Liquid Setpoints.

Condenser

A detailed view of all condenser parameters, including control of the liquid level functions.

Return

Returns the display to the previous screen.

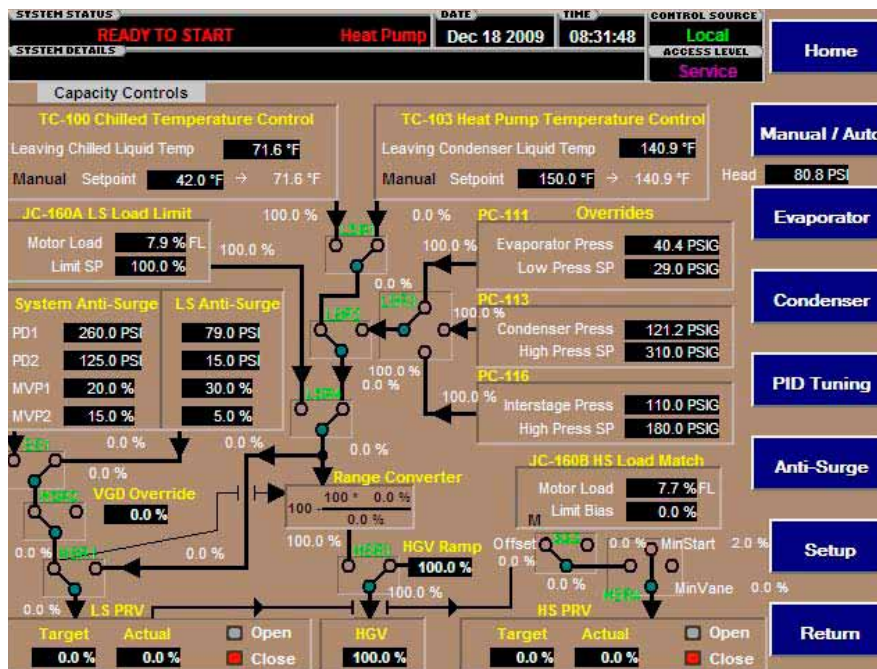

LD15247

FIGURE 51 - HEAT PUMP MODE

MANUAL AUTO STATION (CAPACITY CONTROLS) SCREEN

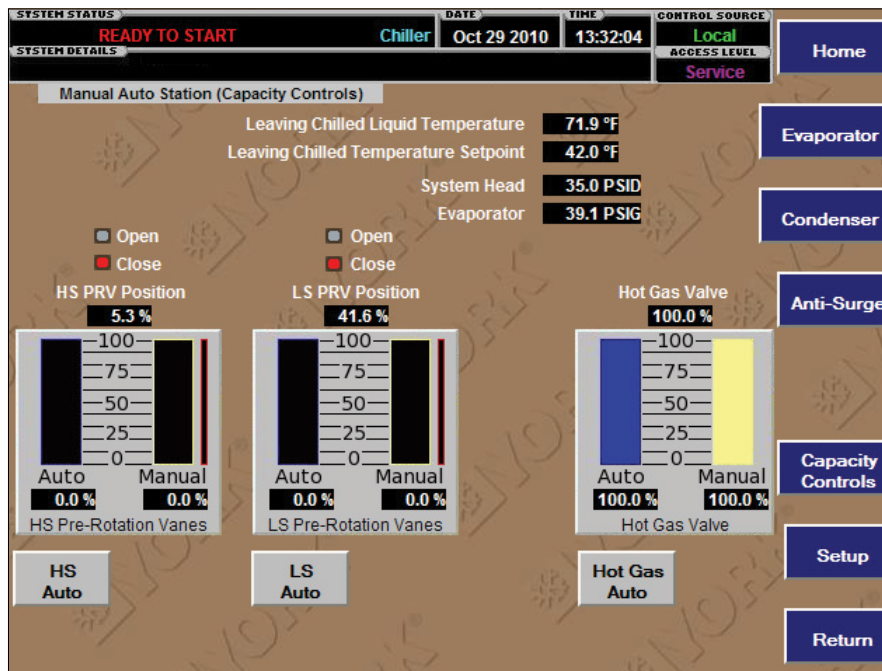

LD15280

FIGURE 52 - MANUAL AUTO STATION (CAPACITY CONTROLS) SCREEN

OVERVIEW

The capacity controls manual-auto station screen can be used to take manual control of all three capacity controls devices. (Putting both sets of vanes in manual control brings up an option on synchronous open and closed keys to synchronously open and close both sets of vanes)

LED symbol indicators are shown for observing pulses fed to each PRV shaded pole actuator motor. The actual PRV position feedback is listed at the TOP of each manual-auto station.

Anti-surge values for both sets of vanes are depicted as a RED bar graph to the right of each station.

If the Low or High Stage vanes are put back into automatic control, above the calculated anti-surge value, the Capacity Controls algorithm will adjust to the manual value and calculate from that point. If released below anti-surge calculation, the station will go into an inhibit condition. The manual value must be increased above anti-surge to transition back to automatic operation.

DISPLAY ONLY

Leaving Chilled Liquid Temperature

Displays the temperature of the chilled liquid as it leaves the evaporator.

Leaving Chilled Temperature Setpoint

Displays the present setpoint to which the chiller is operating, whether controlled locally or remotely.

System Head

Displays the system head differential pressure.

PROGRAMMABLE

HS Auto

Access Level Required: OPERATOR

Refer to *Figure 26 on page 55* for operational use.

LS Auto

Access Level Required: OPERATOR

Refer to *Figure 40 on page 81* for operational use.

Hot Gas Auto

Access Level Required: OPERATOR

Refer to *Figure 26 on page 55* for operational use.

NAVIGATION

Home

Used to provide additional Home information.

Evaporator

A detailed view of all evaporator parameters, including the programmable Leaving Chilled Liquid Setpoints.

Condenser

A detailed view of all condenser parameters, including control of the liquid level functions.

Anti-Surge

This screen displays data about the Anti-Surge.

Capacity Controls

Returns the display to view the Capacity Controls Screen.

Setup

This screen provides a single location to program the most common system setpoints. It is also the gateway to many of the general system setup parameters such as I/O configuration, Communications Setup, Software Maintenance, Trending, and diagnostics.

Return

Returns the display to the previous screen.

PID TUNING SCREEN

The screenshot shows the PID Tuning Screen with the following details:

- System Status:** READY TO START
- Chiller Mode:** Chiller
- Date/Time:** Dec 29 2009 09:15:17
- Control Source:** Remote
- Access Level:** Service
- Buttons:** Home, Manual / Auto, Overrides, Capacity Controls, Setup, History
- Manual TC-100 Chilled Water Out Temp:**
 - LChWT PV = 71.6 °F
 - SP = 42.0 °F
 - PRV: P = 0.600, I = 2.000, D = 0.000
 - HGV: P = 0.500, I = 3.000, D = 0.000
 - Output = 0.0 %
 - Setpoint Ramp Rate: 1 = 0.1 °F Per Sec, 2 = 0.1 °F Per Sec
 - HS PRV = 0.0 %, LS PRV = 0.0 %, HGV = 100.0 %
 - HGV Ramp Rate = 0.4 % Per Sec
- M JC-160B HS Motor Load:**
 - HS Load PV = 7.0 %
 - LS Load SP = 100.0 %
 - HS Limit = 100.0 %
 - BIAS = 0.0 %
 - P = 0.500, I = 2.000, D = 0.001
 - Ramp Rate = 1.0 % Per Sec
 - Output = 0.0 %

LD15261

FIGURE 53 - PID TUNING SCREEN

OVERVIEW

This screen would normally only be used on initial start-up by a YORK Service Technician to fine tune the capacity controls. The effects of changes to the PID tuning are observed by changing back to Screen #10 : CAPACITY CONTROLS.

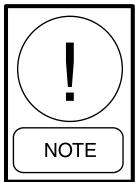

Contact a YORK Service Agent if adjustments are required to the Capacity Controls tuning.

The present status of the adjustable tuning parameters are shown for each PID controller and other programmed control functions. The PID controllers are configured using ISA equations, with the following values:

- SP = Set Point
- P = Controller Gain
- I = Integral Gain (Reset)
- D = Derivative Gain

For the setpoint of TC-100 and TC-103, the “LOC SP=” text changes to “REM SP=” when being controlled remotely. See Evaporator Screen in Chiller Mode, or Condenser Screen for Heat Pump Mode, for details on changing the setpoint of these controls.

Changing Tuning Parameters

To change tuning parameters touch the numeric entry area, and a cursor will appear where a new value can be entered. Enter the new value and press the [SUBMIT] button.

The tuning values shown are estimated only and may require adjustment depending on actual chiller operating conditions.

Ramp Values

The Ramp Rates are used on chiller startup. The PID controls are put into manual, and ramped slowly to reach their setpoints without overshoot. The actual running conditions of the water system will determine whether faster or slower ramp rates are appropriate.

TC-100 has a setpoint ramp rate in Degrees Temperature per Second for both Single Stage and Two Stage operation respectively indicated by a 1 and 2.

The Hot Gas Valve has a startup ramp rate which can be defined here. The Hot Gas Valve starts at 100% open and ramps closed at this ramp rate until the ramp is complete, or a setpoint, or override is reached.

JC-160B

The HS motor load limiter controller has two functions, depending on the system configuration.

- If the system is configured for load matching between the stages, then the setpoint for this controller comes from the actual motor load of the Low Stage. LS LOAD is displayed next to the setpoint.

The BIAS setpoint controls the balance of the compressor load matching. A positive value will load the high stage this much more than the low stage. A negative value will keep the high stage unloaded this much less percent than the low stage.

- If the system is configured for an offset High Stage compressor operation, then this demand limiter PID takes its setpoint from the HS Limit setpoint block below the SP= value. HS LIMIT is displayed in this case.

NAVIGATION

Home

Used to provide additional Home information.

Overrides

Returns the display to view the Capacity Override Tuning Parameters.

Capacity Controls

Returns the display to view the Capacity Controls Screen.

Setup

This screen provides a single location to program the most common system setpoints. It is also the gateway to many of the general system setup parameters such as I/O configuration, Communications Setup, Software Maintenance, Trending, and diagnostics.

History

This screen provides access to a Time stamped Record of shutdown conditions.

OVERRIDES SCREEN

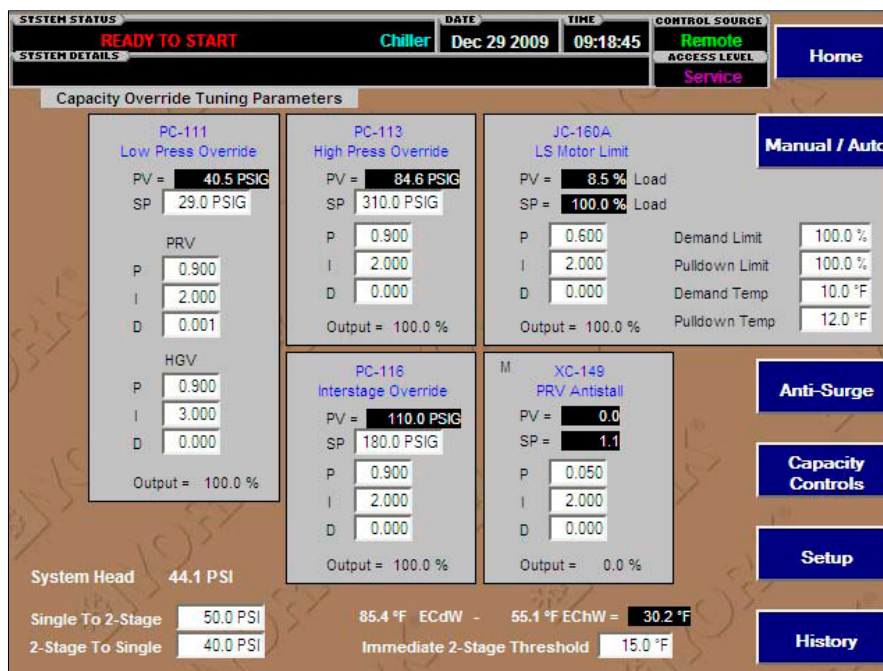

LD15262

FIGURE 54 - OVERRIDES SCREEN

OVERVIEW

The Override Tuning Screen allows the operator to adjust capacity controls tuning parameters. The screen depicts four control loops:

- (PC-111) Evaporator Pressure
- (PC-113) Compressor Discharge Pressure
- (PC-116) Interstage Pressure
- (JC-160A) LS Motor Load Limiter

Refer to PID tuning procedures to adjust these loops.

JC-160A

The Low Stage demand limiter PID has a pulldown function associated with it. The pulldown is not time-based like conventional pulldown timers. This pulldown is temperature-based over a sliding scale of demand limitation. As the chiller attains the desired setpoint, from a standby state, the demand limit is slowly allowed to increase. This prevents a sudden change of demand limit and also keeps the system from overload during and ice-building start up.

Enter the higher of the two temperatures in the **Pulldown Temp** box. This is the starting entering chilled temperature. Enter the lower of the demand limit percentages in the **Pulldown Lim** box. This is the demand limit allowed during the pulldown of the system. As the system reaches setpoint, the lower of the two entering chilled temperatures in the **Demand Temp** box will result in a higher allowable Demand Limit in the **Demand Lim** box. The Demand Temp should be greater than the actual entering chilled liquid temperature setpoint, by several degrees.

XC-149

The PRV Anti-stall controller will become active when the VGD gap on the LS compressor is fully extended. This controller will open the PRV's on the LS compressor to maintain the stall setpoint given on the LS VGD screen. Refer to the LS VGD controller screen. As the stall noise decreases, the PRV's are allowed to return to normal as the XC-149 controller goes back to a zero output.

PROGRAMMABLE

Single To 2-Stage

Access Level Required: SERVICE

This setpoint determines at what head pressure (condenser pressure – evaporator pressure) the High Stage booster compressor should be brought online. During operation with the single Low Stage compressor the head may increase above the ability for one stage of compression to handle (high duty head or brine duty). Therefore, the booster is brought online to increase the lift.

2-Stage To Single

Access Level Required: SERVICE

This setpoint determines at what head pressure the High Stage booster compressor is not needed to accomplish the lift of the system. Running the High Stage compressor unnecessarily is a waste of energy (low head duty). Below this threshold a single stage of compression is enough to produce the system lift; therefore, the booster is dropped offline until it is needed again.

Immediate Two-Stage Threshold

Access Level Required: SERVICE

The difference between the entering condenser water and entering chilled water predicts the head conditions when the CYK is started. If the difference in temperature is above this programmable setpoint, the CYK will

start both compressors as quickly as possible when it is started. If the difference is below this value, the head will not be great, and only the low stage is needed to start with.

NAVIGATION

Home

Used to provide additional Home information.

Anti-Surge

This screen displays data about the Anti-Surge.

Capacity Controls

Returns the display to view the Capacity Controls Screen.

Setup

This screen provides a single location to program the most common system setpoints. It is also the gateway to many of the general system setup parameters such as I/O configuration, Communications Setup, Software Maintenance, Trending, and diagnostics.

History

This screen provides access to a Time stamped Record of shutdown conditions.

3

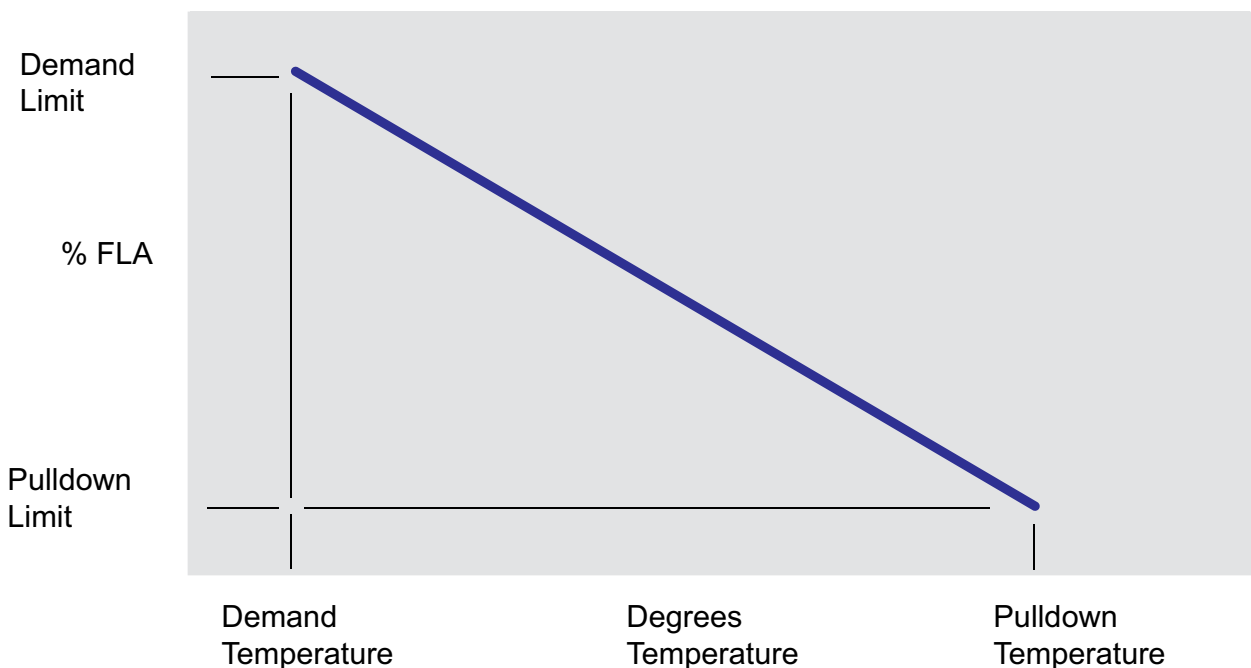
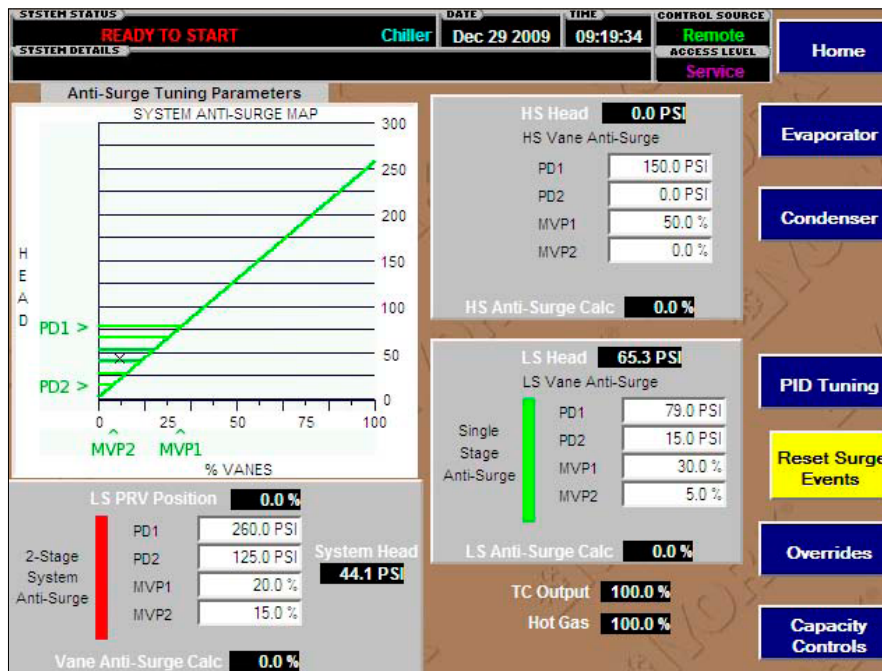

FIGURE 55 - TEMPERATURE-BASED DEMAND LIMITER FUNCTION

LD15234

ANTI-SURGE SCREEN



LD15263

FIGURE 56 - ANTI-SURGE SCREEN

OVERVIEW

Depicted on the Anti-surge tuning parameters screen is a plot showing the surge area as a function of compressor head versus PRV position. The area to the left of the line, highlighted in red, are the conditions under which surge can be expected to occur.

ANTI-SURGE MAP

PD1 is the maximum system head pressure as defined by the entry fields.

PD2 is the minimum system head pressure as defined by the entry fields.

MVP1 is the minimum allowable vane position at the maximum system head pressure PD1.

MVP2 is the minimum allowable vane position at the minimum system head pressure PD2.

An "X" on the plot shows the current Low Stage Vane operating point.

There are entry fields for three separate surge curves.

- The LS ANTI-SURGE CALC is a surge curve for single stage CYK operation.
- The 2-STAGE SYSTEM ANTI-SURGE CALC is a surge curve for 2-stage CYK operation.
- The HS ANTI-SURGE CALC is a surge curve for just the high stage compressor alone. This can be used to keep the High Stage Vanes from adjusting below the percentage of the Low Stage vanes at low loads.

HS curve is not depicted in a graphic.

These MVP1 and MPV2 are typically zero for most applications.

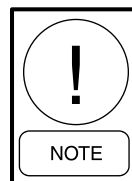

The Anti-surge parameters must be determined experimentally during the commissioning procedure. Values shipped with the unit are only default.

Refer to *Anti-Surge Tuning on Page 48* for details on anti-surge control line operation and tuning.

NAVIGATION

Home

Used to provide additional Home information.

Evaporator

A detailed view of all evaporator parameters, including the programmable Leaving Chilled Liquid Setpoints.

Condenser

A detailed view of all condenser parameters, including control of the liquid level functions.

PID Tuning

Returns the display to view the Capacity Controls Tuning Parameters.

Overrides

Returns the display to view the Capacity Override Tuning Parameters.

Capacity Controls

Returns the display to view the Capacity Controls Screen.

SETUP SCREEN

LD15255

FIGURE 57 - SETUP SCREEN

OVERVIEW

Provides access to advanced functions and setup of the CYK.

DISPLAY

PLC Clock Present

Shows present date and time.

Last Start Date

Shows the date and time of the last motor start.

Runtime Last Start

Shows the days, hours and minutes of the last motor run interval.

INTERACTIVE

Reset Start Count

Access Level Required: FACTORY

Resets the start counter (restricted access).

Reset Run Timer

Access Level Required: FACTORY

Resets the run timer (restricted access).

Reset Anti-Recycle

Access Level Required: FACTORY

Resets the anti-recycle (restricted access).

Chiller Mode / Heat Pump Mode

Access Level Required: OPERATOR

Toggles between Chilling Operation and Heat Pump operation.

NAVIGATION

Home

Used to provide additional Home information.

Trending

Returns the display to view the Trending Screen.

Diagnostics

Returns the display to view the Diagnostics Screen.

Test Outputs

Returns the display to view the Test Outputs Screen.

Setup

This screen provides a single location to program the most common system setpoints. It is also the gateway to many of the general system setup parameters such as I/O configuration, Communications Setup, Software Maintenance, Trending, and diagnostics.

Serial Port Setup

Returns the display to view the Serial Port Setup Screen.

Ethernet

Returns the display to view the Ethernet Screen.

History

This screen provides access to a Time stamped Record of shutdown conditions.

TEST OUTPUTS SCREEN



LD16096

FIGURE 58 - TEST OUTPUTS SCREEN

OVERVIEW

The Test Output screen is used to test a solenoid or digital valve. Pressing the key corresponding to the device name, will cause it to turn ON momentarily for testing purposes.

INTERACTIVE

Each solenoid in the system, as well as the oil transfer pump has a test button associated with it on this screen.

Pressing the corresponding button will engage the output for two seconds for test purposes. For slow valves the output will be engaged for a longer time delay.

NAVIGATION

Home

Used to provide additional Home information.

Setup

This screen provides a single location to program the most common system setpoints. It is also the gateway to many of the general system setup parameters such as I/O configuration, Communications Setup, Software Maintenance, Trending, and diagnostics.

SETPOINTS 1 SCREEN

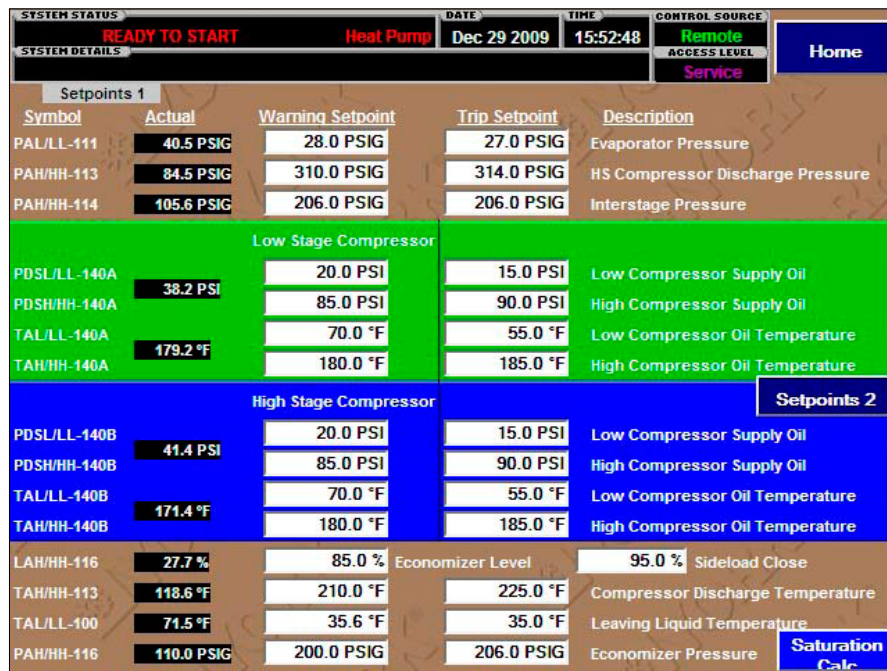

LD15260

FIGURE 59 - SETPOINTS 1 SCREEN

OVERVIEW

This screen is only available under the highest access level.

The Safety setpoints are the thresholds of safe operation for the York CYK chiller. Each CYK is designed with unique applications in mind, therefore each will have unique safety setpoints.



Consult the York Factory before attempting to change any safety setpoints. These thresholds protect the CYK chiller from operations outside its design parameters. Safe operation of the chiller, and warranty claims, will be compromised by unauthorized changes.

NAVIGATION

Home

Used to provide additional Home information.

Setpoints 2

Returns the display to view the Setpoints 2 Screen.

Saturation Calc

Returns the display to view the Saturation Calc Screen.

SETPOINTS 2 SCREEN

The screenshot displays the 'SETPOINTS 2' screen with the following data:

SYSTEM STATUS	READY TO START	Heat Pump	DATE	TIME	CONTROL SOURCE
SYSTEM DETAILS			Dec 29 2009	15:53:34	Remote
					Service

Control Stop	
Control Stop Chiller Temp	50.0 °F
Control Stop Heat Pump Temp	90.0 °F
Control Stop Max Timeout	120 SEC

Current Matching	
PD1	260.0 PSI High Head Offset 45.0 %
PD2	125.0 PSI Low Head Offset 20.0 %

Ramps And Start Positions	
PRV Ramp (Per Sec)	0.3 %
Start Unload	2.0 %
LS PRV Start	2.0 %
HS PRV Start	2.0 %
PRV Response Gain	4.85

LS Motor Under-Current Trip	10.0 %
HS Motor Under-Current Trip	10.0 %
LS Motor Over-Current Trip	105.0 % 40 SEC
HS Motor Over-Current Trip	105.0 % 40 SEC
Standby Lube Cycle Interval (0=Disabled)	24 HRS
PRV Ramp Release (Icool Inventory)	3.0 %
LCV-114 Open On Start	100.0 %
LCV-116 Open On Start	30.0 %
LCV-117 Open Percentage On Start	50.0 %
Inlet Valve Level Control Setpoint Bias	-5.0 %
Economizer Level Loss Bias (From SP)	10.0 %

SS1 Ramp	0.5 % Per Sec
Minvane Low Limit	3.0 %
HS Catchup Offset	10.0 %

ON Bias From Setpoint / OFF Percent Change Registered	
Economizer Gas Bleed Solenoid:ON	15.0 % OFF 1.0 %

LD15249

FIGURE 60 - SETPOINTS 2 SCREEN

OVERVIEW

The miscellaneous setpoints screen allows access to programmable features that control the more high level parameters of the CYK control system. Care is to be taken when accessing these setpoints.

HS PRV Offset vs Load Matching Control

There are two modes of operation for the HS compressor capacity control.

Load Matching

The HS compressor can be selected to run equal compression ratio as the LS compressor, as in a radiator or heat pump application. This selection is convenient in that both compressor will use approximately the same percent work to accomplish the total head. If LOAD MATCHING operation is selected the HS compressor vanes will be operated on a demand limiter PID with the setpoint being slaved to the LS compressor motor current. In this way the compressors will track nicely together always sharing the lift.

This method is not ideal when the compressors are selected to operate more efficiently with disproportionate sharing of compression ratios.

HS PRV Offset

In the case of an ice building application with disproportionate expectations of lift between the HS and LS compressors, another control method is needed. This can also be used in other modes for an alternative mode of HS compressor operation.

The two percent values of LOW HEAD OFFSET and HIGH HEAD OFFSET, must be supplied to create a linear scale between the lift requirements defined by System Antisurge PD1 and PD2 in terms of differential pressure. So, at a relatively high lift across the entire system, the HS compressor operates its PRV's the HIGH HEAD OFFSET in percent above the LS compressor vane position. The offset is calculated from here down to the LOW HEAD OFFSET position at PD2 in differential pressure, over a calculated linear scale.

The Offset slope can be either Positive or Negative, meaning that the HIGH HEAD OFFSET can be (and often is) less than the LOW STAGE OFFSET.

During this mode of operation the HS compressor demand limit (current limit) controller is active and will override the offset function if the demand on the HS motor is too high.

This method of High Stage Compressor control should be used in situations where the best efficiency is obtained by an intermediate temperature that is not equal compression ratio sharing between stages.

Figure 61 on page 111 illustrates the HS PRV offset function.

CONTROL STOP

Control Stop Chiller Temp Setpoint

This is the setpoint that the TC-100 temperature control will receive during a controlled stop procedure. The setpoint should be higher than the inlet chilled water temperature to unload the chiller quickly.

Control Stop Heat Pump Temp Setpoint

This is the setpoint that the TC-103 temperature control will receive during a control stop procedure in Heat Pump mode. The setpoint should be lower than the inlet condenser water temperature to insure a quick machine unload sequence.

CONTROL STOP MAX TIMEOUT

This time governs the maximum time that a control stop cycle should be allowed to take. If the chiller doesn't unload fast enough, this is the maximum time allowed of running after the STOP button is pressed.

RAMPS AND START POSITIONS

PRV Ramp

Ramp rate that the vanes will be limited to during a chiller start.

Start Unload

LS vane position limitation during two stage transition from single stage to two stage.

LS PRV Start

Open the vanes this small percentage before engaging the drive motor while in prelude.

HS PRV Start

Open the vanes this small percentage before engaging the drive motor while in prelude.

PRV Response Gain

The PRV's have a positioner algorithm that pulses them open or closed based on their target signal from the capacity controls. This gain is defaulted to 4800 for most compressors. Very small compressors have smaller faster PRV actuator motors, which may require the gain to be reduced to 4000.

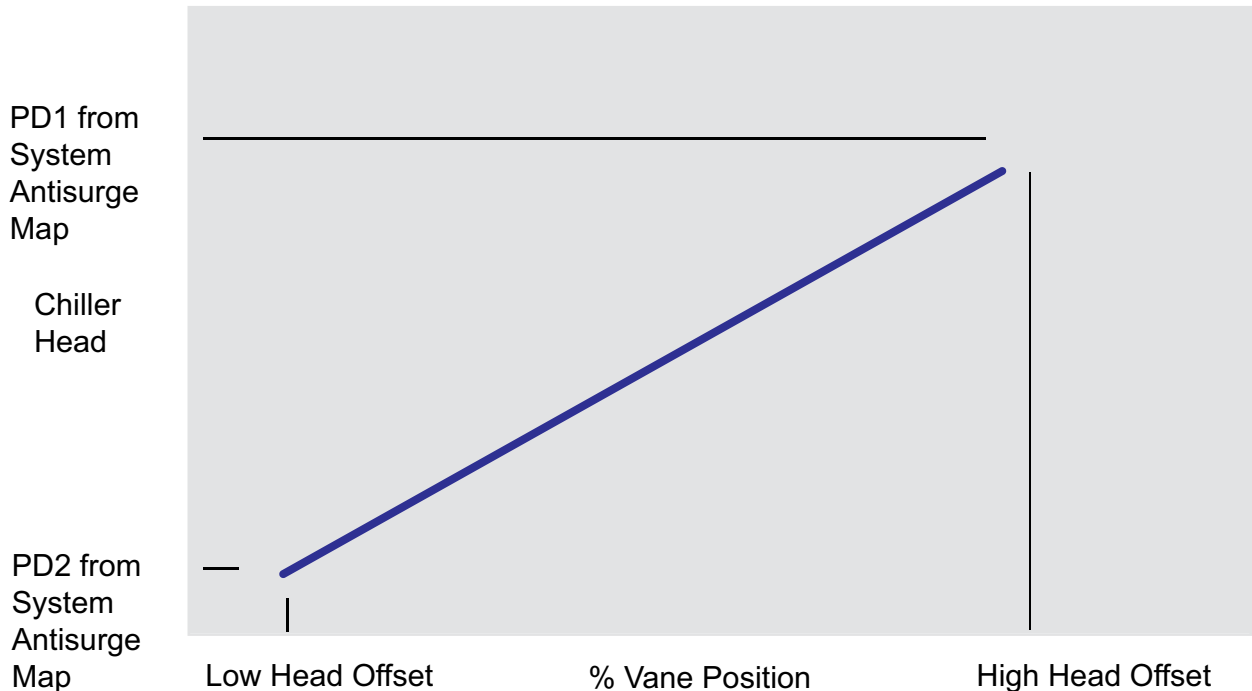

FIGURE 61 - HS PRV OFFSET CONTROL SCALE FUNCTION

LD15235

SS1 Ramp Rate

Selector Switch 1 has a rate of change limiter associated with it, which limits the rate of change of the anti-surge calculated value to the number entered here. This prevents large transient changes caused by tower condition upsets from affecting stable chiller operation.

Minvane Low Limit

This value is the minimum calculated value allowed out of SS1. If SS1 were to go to zero, then the ratiometric hot gas calculation would not work. Therefore this value must be greater than zero.

HS Catchup Offset

This percentage value defines how far the HS vanes need to be above the LS vanes, before the LS vanes are allowed to resume Temperature Control, when a two-stage transition occurs.

Miscellaneous Settings**Motor Undercurrent Trip (LS and HS)**

If the motor current does not exceed this value during run, then the load feedback is malfunctioning and must be investigated.

Standby Lube Cycle Interval

Hours of delay between shaft seal lubrication cycles. A shaft seal lubrication cycle is a 3 minute lubrication cycle.

PRV Ramp Release

This is the percentage of LS PRV position that the LS compressor is held at to establish an economizer level prior to initial start ramp up. This value is ignored after the economizer level setpoint is met.

LCV-114 Open On Start

On chiller start, the LCV-114 valve is forced to preset to this percentage.

LCV-117 % Open On Start

On chiller start, the LCV-117 valve is forced to preset to this percentage.

LCV-116 % Open On Start

On chiller start, the LCV-116 valve is forced to preset to this percentage.

Inlet Valve Level Control Setpoint Bias

The PRV Ramp Release is held until the economizer level setpoint plus this (negative) value is obtained in the economizer vessel.

Economizer Level Loss Bias

In two stage operation, if the level in the economizer goes below the setpoint minus this value, then restart the economizer level control ramp. Minimizes oscillations in regaining level control.

Economizer Gas Bleed Solenoid (On and Off)

ON – In single stage operation, if the economizer level goes below the setpoint minus this value, the gas bleed solenoid PCV-117 control becomes active.

OFF – In single stage operation, in order to turn off the Economizer Gas Bleed Solenoid the level must make an upward transition of this many percent.

NAVIGATION**Home**

Used to provide additional Home information.

Setpoint 1

Returns the display to view the Setpoint 1 Screen.

PRESSURE CALIBRATION SCREEN

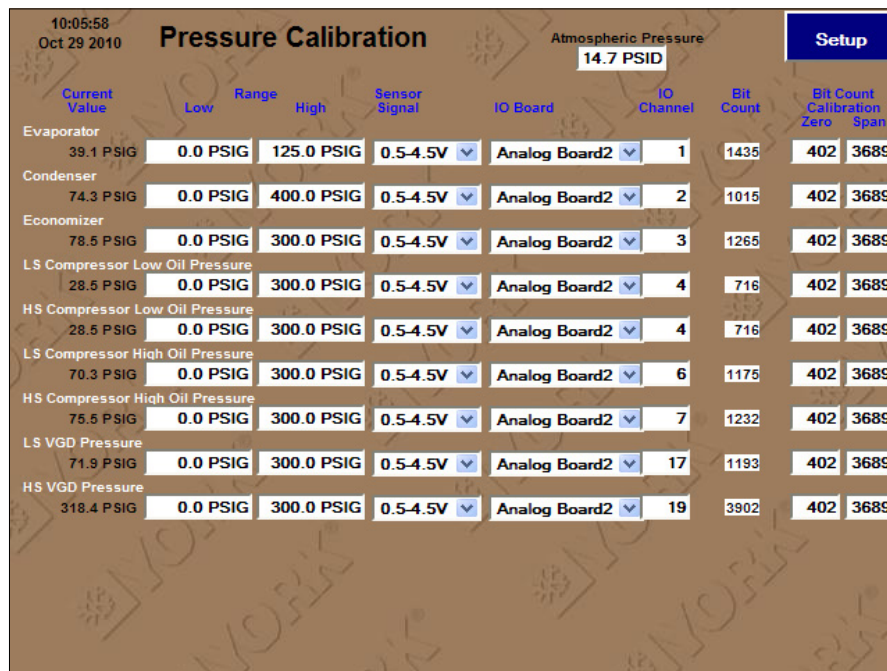

LD15268

FIGURE 62 - PRESSURE CALIBRATION SCREEN

OVERVIEW

This screen is only available under the highest access level.



Scaling values in the processor must agree with the marked scaling values on each instrument. If the scaling is not correct, the safe operation of the chiller is jeopardized. Only change scaling under the direction of the factory.

The pressure sensors can be configured for many types of inputs. Standard configuration uses YK Ratiometric pressure sensors. Signal type is 0.5 to 4.5 VDC. Each channel should be calibrated for zero and span bit counts for the highest accuracy.

DISPLAY

Displays and controls the instrument scaling of each Pressure transducer on the chiller.

PROGRAMMABLE

Atmospheric Pressure

Access Level Required: SERVICE

Atmospheric pressure is defined for Absolute Pressure reading references. (Typically 14.7PSI)

NAVIGATION

Setup

This screen provides a single location to program the most common system setpoints. It is also the gateway to many of the general system setup parameters such as I/O configuration, Communications Setup, Software Maintenance, Trending, and diagnostics.

TEMPERATURE CALIBRATION SCREEN

14:20:45
Apr 15 2013

Temperature Calibration

Setup

Current Value	Offset	Range	Low	High	Sensor Signal	IO Board	IO Channel
Chilled Water Out Temperature 46.8 °F	3.0 °F				ICTD	Analog Board1	1
Chilled Water In Temperature 55.7 °F	0.1 °F				ICTD	Analog Board1	2
Condenser Water Out Temperature 146.4 °F	-0.4 °F				ICTD	Analog Board1	4
Condenser Water In Temperature 97.1 °F	-0.0 °F				ICTD	Analog Board1	3
Evaporator Refrigerant Liquid Temperature 46.3 °F	-0.2 °F				ICTD	Analog Board1	5
LS Comp Refrig Discharge Temperature 79.6 °F	0.0 °F				ICTD	Analog Board1	6
HS Comp Refrig Discharge Temperature 106.1 °F	-0.2 °F				ICTD	Analog Board1	7
Subcooled Liquid Temperature 121.1 °F	-0.2 °F				ICTD	Analog Board1	8
LS Compressor Oil Temperature 102.1 °F	-0.0 °F				ICTD	Analog Board1	9
HS Compressor Oil Temperature 109.5 °F	0.0 °F				ICTD	Analog Board1	10

LD15269

FIGURE 63 - TEMPERATURE CALIBRATION SCREEN

OVERVIEW

The Temperature inputs are set for ICTD (Integrated Circuit Temperature Detector) by default. These are calibrated to a known temperature by the offset column. The usable range of readings is adjustable.

DISPLAY

Displays and controls the instrument scaling of each temperature detector on the chiller.

PROGRAMMABLE

Temperature Probes

Access Level Required: SERVICE

Temperature probes can be calibrated in Service Mode by entering the actual temperature into the first column, or calculating an offset and entering it into the second column. Press the SUBMIT key on the keypad to confirm changes.

NAVIGATION

Setup

This screen provides a single location to program the most common system setpoints. It is also the gateway to many of the general system setup parameters such as I/O configuration, Communications Setup, Software Maintenance, Trending, and diagnostics.

MISCELLANEOUS CALIBRATION SCREEN

10:09:24
 Oct 29 2010

Miscellaneous Calibration Page 2 Setup

Current Value	Range Low	Range High	Sensor Signal	IO Board	IO Channel	Bit Count	Bit Count Calibration Zero	Bit Count Calibration Span
High Stage Motor Current 6.6 AMPS	200.0 AMPS		4-20mA	Analog Board2	16	905	819	3443
LS Oil Reservoir Level 66.6 %	0.0 %	100.0 %	0-5V	Analog Board2	9	2728	0	4095
HS Oil Reservoir Level 70.8 %	0.0 %	100.0 %	0-5V	Analog Board2	10	2898	0	4095
Subcooler Liquid Level 49.0 %	0.0 %	100.0 %	4-20mA	Analog Board1	17	2008	0	4095
Economizer Liquid Level 31.2 %	0.0 %	100.0 %	4-20mA	Analog Board1	18	1841	819	4095
LS PRV Position 41.6 %	0.0 %	100.0 %	0-10V	Analog Board1	14	1705	0	4095
HS PRV Position 5.3 %	0.0 %	100.0 %	0-10V	Analog Board1	15	215	0	4095

<u>LOW STAGE</u>	<u>HIGH STAGE</u>
FLA <input type="text" value="100.0 AMP"/>	FLA <input type="text" value="100.0 AMP"/>
	20 mA Level <input type="text" value="200 Amps"/>

LD15270

FIGURE 64 - MISCELLANEOUS CALIBRATION SCREEN

OVERVIEW

The Miscellaneous Calibration page configures any inputs that are not pressures or temperatures on the standard system. The motor CT's range should be entered with the CT ratio from the Sales Order. The FLA should be entered with the full load amps of the motors from the Sales Order.

NAVIGATION

Setup

This screen provides a single location to program the most common system setpoints. It is also the gateway to many of the general system setup parameters such as I/O configuration, Communications Setup, Software Maintenance, Trending, and diagnostics.

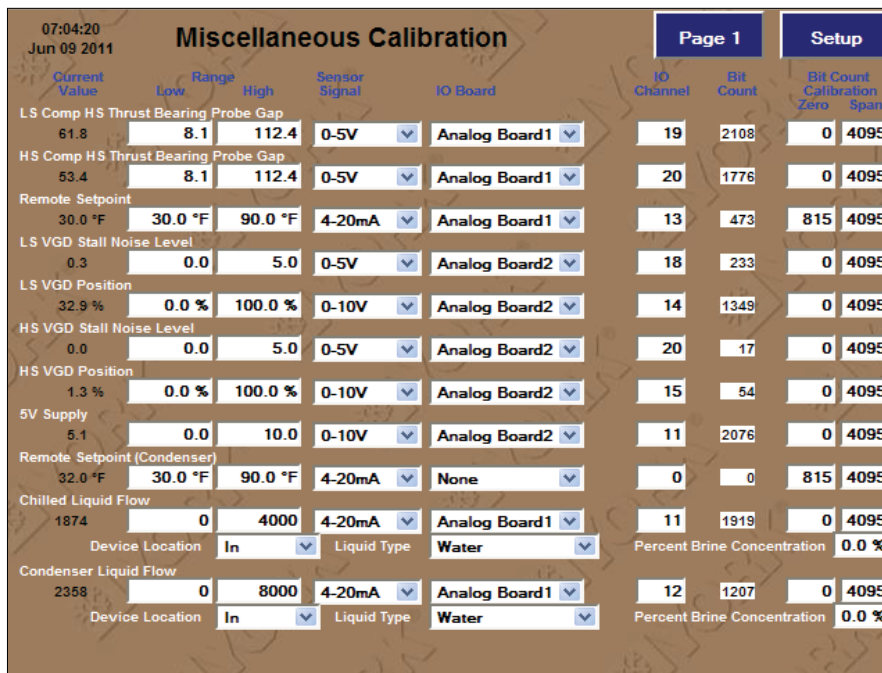

LD15270a

FIGURE 62 - SCALING – MISCELLANEOUS INPUTS SCREEN (CONT'D)

The technician must configure the engineering units of the flowmeter in GPM both Low and High. The sensor signal from the dropdown box (4-20mA is preferred). The IO Board analog board and the channel to which the instrument is attached. The technician must also determine the flowmeter device location, whether it is on the IN/OUT or an AVERAGE of the water box nozzle

temperatures. The liquid type must also be selected for the capacity calculation to work out correctly. The liquid can be *water/ethylene glycol/ or propylene glycol*. The concentration of the brine solution must also be entered in percent volume. If the liquid is water, then the concentration of brine is 0%.

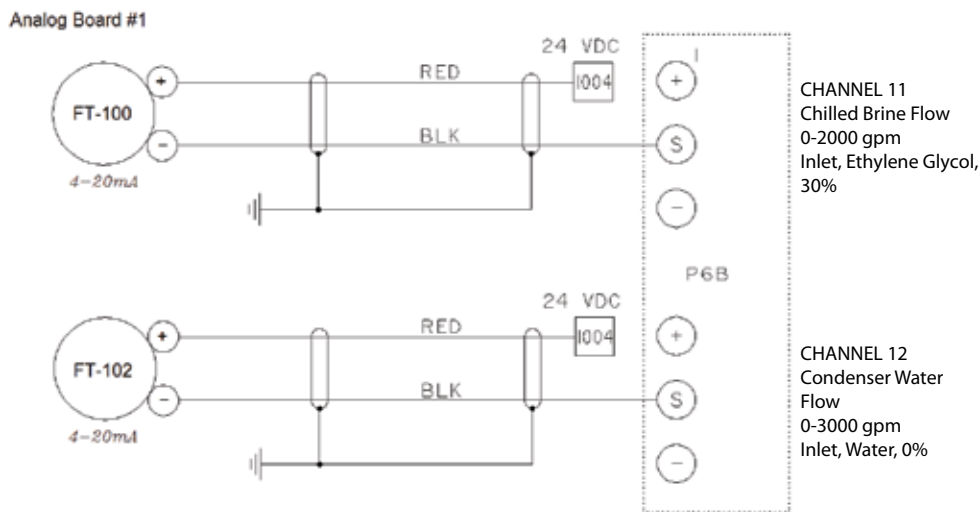

LD16095

FIGURE 65 - FLOW INSTRUMENTS WIRING

DIGITAL INPUT CONFIGURATION SCREEN

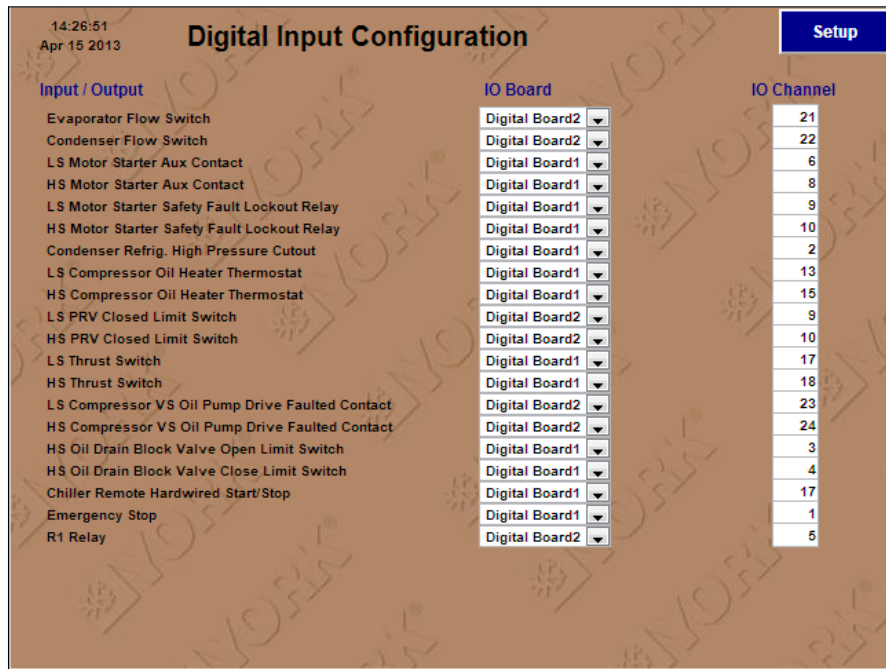

LD15272

FIGURE 66 - DIGITAL INPUT CONFIGURATION SCREEN

OVERVIEW

The Digital Input Configuration Screen allows a user with sufficient privilege to assign digital inputs to the correct Board and Channel.

This should only be changed under direction of the factory.

DIGITAL OUTPUT CONFIGURATION SCREEN

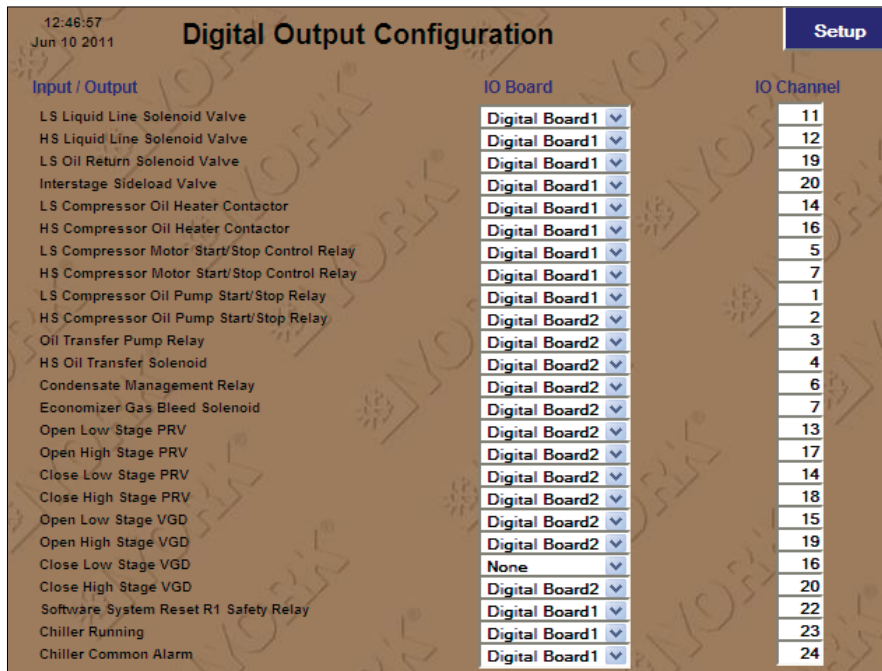

LD16102

FIGURE 67 - DIGITAL OUTPUT CONFIGURATION SCREEN

OVERVIEW

The Digital Output Configuration Screen allows a user with sufficient privilege to assign digital outputs to the correct Board and Channel.

This should only be changed under direction of the factory.

AUXILIARY ANALOG CONFIGURATION SCREEN



LD16103

FIGURE 68 - AUXILIARY ANALOG CONFIGURATION SCREEN

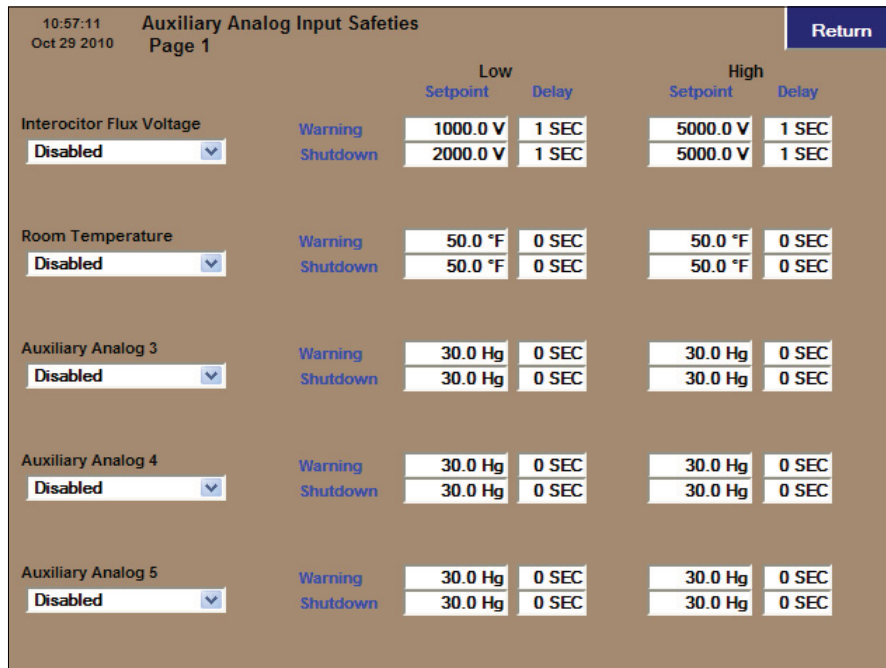

LD15279

FIGURE 69 - AUXILIARY ANALOG INPUT SAFETIES SCREEN

OVERVIEW

The Auxiliary Analog Configuration screen is used to allow the user to set the operating safeties of Auxiliary inputs.

Drop down menu boxes are provided for the following: Auxiliary Analogs 1 through 24:

- **Disabled** – The auxiliary channel will not be monitored for warnings or shutdowns.
- **When Running** – The auxiliary channel will be monitored for warning and shutdown occurrences only when the compressor is in the run state.
- **Always** – The auxiliary channel will be monitored for warning and shutdown occurrences at all times (Running or not).

The following setpoints are provided for each Auxiliary Analog channel in *Figure 69 on page 119*.

Low Warning Setpoint – This setpoint specifies the Low Warning alarm threshold. In the event that the associated auxiliary analog input falls below this value for a period of time exceeding the Low Warning Delay, an Auxiliary Low Warning will be issued.

Low Warning Delay – This setpoint specifies the period of time that the associated auxiliary analog input must remain below the Low Warning Setpoint before an Auxiliary Low Warning will be issued.

Low Shutdown Setpoint – This setpoint specifies the Low Shutdown threshold. In the event that the associated auxiliary analog input falls below this value for a period of time exceeding the Low Shutdown Delay, an Auxiliary Low Shutdown will be issued, and the compressor will stop.

Low Shutdown Delay – This setpoint specifies the period of time that the associated auxiliary analog input must remain below the Low Shutdown Setpoint before an Auxiliary Shutdown will be issued.

High Warning Setpoint – This setpoint specifies the High Warning threshold. In the event that the associated auxiliary analog input exceeds this value for a period of time exceeding the High Warning Delay, an Auxiliary High Warning will be issued.

High Warning Delay – This setpoint specifies the period of time that the associated auxiliary analog input must remain above the High Warning Setpoint before an Auxiliary High Warning will be issued.

High Shutdown Setpoint – This setpoint specifies the High Shutdown alarm threshold. In the event that the associated auxiliary analog input exceeds this value for a period of time exceeding the High Shutdown Delay, an Auxiliary High Shutdown will be issued, and the compressor will stop.

High Shutdown Delay – This setpoint specifies the period of time that the associated auxiliary analog input must remain above the High Shutdown Setpoint before an Auxiliary Shutdown will be issued.

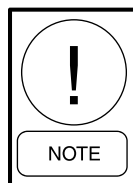

If you wish to bypass the warnings and utilize only the shutdown feature, then set all warning values outside of the shutdown values.

AUXILIARY ANALOG CALIBRATION SCREEN, PAGE 1

Page 1 Name	Calibration Page 2	Aux Analog Configuration	Current Value	Offset	Range Low	High
Test Pot			0.0 %	0.0 %	0.0 %	100.0 %
Room Temperature			73.8 °F	-30.5 °F		
Auxiliary Analog 3			0.0	0.0	0.0	100.0
Auxiliary Analog 4			30.0 Hg	-0.0 PSID	30.0 Hg	485.3 PSIG
Auxiliary Analog 5			30.0 Hg	-0.0 PSID	30.0 Hg	485.3 PSIG
Auxiliary Analog 6			30.0 Hg	-0.0 PSID	30.0 Hg	485.3 PSIG
Auxiliary Analog 7			30.0 Hg	-0.0 PSID	30.0 Hg	485.3 PSIG
Auxiliary Analog 8			30.0 Hg	-0.0 PSID	30.0 Hg	485.3 PSIG
Auxiliary Analog 9			30.0 Hg	-0.0 PSID	30.0 Hg	485.3 PSIG
Auxiliary Analog 10			30.0 Hg	-0.0 PSID	30.0 Hg	485.3 PSIG
Auxiliary Analog 11			30.0 Hg	-0.0 PSID	30.0 Hg	485.3 PSIG
Auxiliary Analog 12			30.0 Hg	-0.0 PSID	30.0 Hg	485.3 PSIG
Auxiliary Analog 13			30.0 Hg	-0.0 PSID	30.0 Hg	485.3 PSIG
Auxiliary Analog 14			30.0 Hg	-0.0 PSID	30.0 Hg	485.3 PSIG
Auxiliary Analog 15			30.0 Hg	-0.0 PSID	30.0 Hg	485.3 PSIG
Auxiliary Analog 16			30.0 Hg	-0.0 PSID	30.0 Hg	485.3 PSIG
Auxiliary Analog 17			30.0 Hg	-0.0 PSID	30.0 Hg	485.3 PSIG
Auxiliary Analog 18			30.0 Hg	-0.0 PSID	30.0 Hg	485.3 PSIG
Auxiliary Analog 19			30.0 Hg	-0.0 PSID	30.0 Hg	485.3 PSIG
Auxiliary Analog 20			30.0 Hg	-0.0 PSID	30.0 Hg	485.3 PSIG
Auxiliary Analog 21			30.0 Hg	-0.0 PSID	30.0 Hg	485.3 PSIG
Auxiliary Analog 22			30.0 Hg	-0.0 PSID	30.0 Hg	485.3 PSIG
Auxiliary Analog 23			30.0 Hg	-0.0 PSID	30.0 Hg	485.3 PSIG
Auxiliary Analog 24			29.8 Hg	0.0 PSID	30.0 Hg	300.0 PSIG

LD15273

FIGURE 70 - AUXILIARY ANALOG CALIBRATION, PAGE 1

CALIBRATION - AUXILIARY ANALOGS

This Auxiliary Analog Calibration Screen can be used to custom name each of the Auxiliary Analog channels as well as performing calibration.

To change a name:

- **Locally, at the Panel** – Use the [TAB] button to scroll down the screen to the text line that you wish to change. Press the [^] (up arrow) button. This will cause the screen to be replaced with an Alpha/Numeric key pad entry screen.

A drop down menu box exists for each of the displayed auxiliary readings.

- **Current Value** – The actual value that is being sensed (taking into account the offset).
- **Offset** – A value entered here will allow the user to compensate for calibration issues with a sensor.
- **Range**
 - Low
 - High

AUXILIARY ANALOG CALIBRATION SCREEN, PAGE 2

Page 2	Calibration Page 1	Aux Analog Configuration	IO Board	IO Channel	Sensor Signal	Sensor Type	Other Units
Test Pot			Analog Board3	3	0-5V	Other	%
Room Temperature			Analog Board3	2	RTD	Temperature	
Auxiliary Analog 3			None	0	1-5V	Other	
Auxiliary Analog 4			None	0	1-5V	Pressure	
Auxiliary Analog 5			None	0	1-5V	Pressure	
Auxiliary Analog 6			None	0	1-5V	Pressure	
Auxiliary Analog 7			None	0	1-5V	Pressure	
Auxiliary Analog 8			None	0	1-5V	Pressure	
Auxiliary Analog 9			None	0	1-5V	Pressure	
Auxiliary Analog 10			None	0	1-5V	Pressure	
Auxiliary Analog 11			None	0	1-5V	Pressure	
Auxiliary Analog 12			None	0	1-5V	Pressure	
Auxiliary Analog 13			None	0	1-5V	Pressure	
Auxiliary Analog 14			None	0	1-5V	Pressure	
Auxiliary Analog 15			None	0	1-5V	Pressure	
Auxiliary Analog 16			None	0	1-5V	Pressure	
Auxiliary Analog 17			None	0	1-5V	Pressure	
Auxiliary Analog 18			None	0	1-5V	Pressure	
Auxiliary Analog 19			None	0	1-5V	Pressure	
Auxiliary Analog 20			None	0	1-5V	Pressure	
Auxiliary Analog 21			None	0	1-5V	Pressure	
Auxiliary Analog 22			None	0	1-5V	Pressure	
Auxiliary Analog 23			None	0	1-5V	Pressure	
Auxiliary Analog 24			None	0	1-5V	Pressure	

LD15273a

FIGURE 71 - AUXILIARY ANALOG CALIBRATION, PAGE 2

This Auxiliary Analog Calibration Screen will show any custom named auxiliaries from Page 1 at the left side of the screen. Use this screen to set the Sensor Signal, Sensor Type, and to change the units if set to Other.

The following informational areas are provided and cannot be changed from this screen:

- **Auxiliary Analogs** – These are the names given to the each of the Auxiliary Analog channels. They may be shown as the original default names, or as names that have been customized (see *Figure 71 on page 122*).
- **IO Board** – The data shown here describes on which Analog board the associated sensor is located.
- **IO Channel** – The data shown here describes on which Analog channel of the Device Source the associated sensor is located.

A drop down menu box exists for each of the displayed auxiliary readings:

Sensor Signal

- None
- 0-5V
- 1-5V
- 4-20mA
- Pot. (Potentiometer)
- ICTD
- RTD
- CT
- 0-20mA
- Vibration
- 0-10V

Sensor Type

- None
- Pressure
- Temperature
- Other

Units if Type is Other - Up to 5 characters may be entered here.

RETRANSMITTING OUTPUTS SCREEN

Output Channel	Input Channel To Retransmit	Input Value	Current Output	IO Board	IO Channel
A	Test Pot	0.0 %	0.0 %	Analog Board3	1
B	Low Stage M	25.4 AMPS	0.0 %	None	0
C	Low Stage M	25.4 AMPS	0.0 %	None	0
D	Low Stage M	25.4 AMPS	0.0 %	None	0
E	Low Stage M	25.4 AMPS	0.0 %	None	0
F	Low Stage M	25.4 AMPS	0.0 %	None	0
G	Low Stage M	25.4 AMPS	0.0 %	None	0
H	Low Stage M	25.4 AMPS	0.0 %	None	0
I	Low Stage M	25.4 AMPS	0.0 %	None	0
J	Low Stage M	25.4 AMPS	0.0 %	None	0
K	Low Stage M	25.4 AMPS	0.0 %	None	0
L	Low Stage M	25.4 AMPS	0.0 %	None	0
M	Low Stage M	25.4 AMPS	0.0 %	None	0
N	Low Stage M	25.4 AMPS	0.0 %	None	0
O	Low Stage M	25.4 AMPS	0.0 %	None	0
P	Low Stage M	25.4 AMPS	50.5 %	None	0

LD15248a

FIGURE 72 - RETRANSMITTING OUTPUTS SCREEN

OVERVIEW

This screen allows the service level user to retransmit any analog input to an analog output channel. This is useful for providing analog signals to a BAS system or remote controller, which does not communicate to the panel.

PROGRAMMABLE

Select the channel A through P and use the drop down list to select the "Input Channel To Retransmit". Then select a spare IO Board and IO channel to re-transmit the data on.

This channel will likely need to be calibrated. Navigate to the Analog Output Calibration and perform a calibration on the newly assigned channel.

ECONOMIZER SCREEN

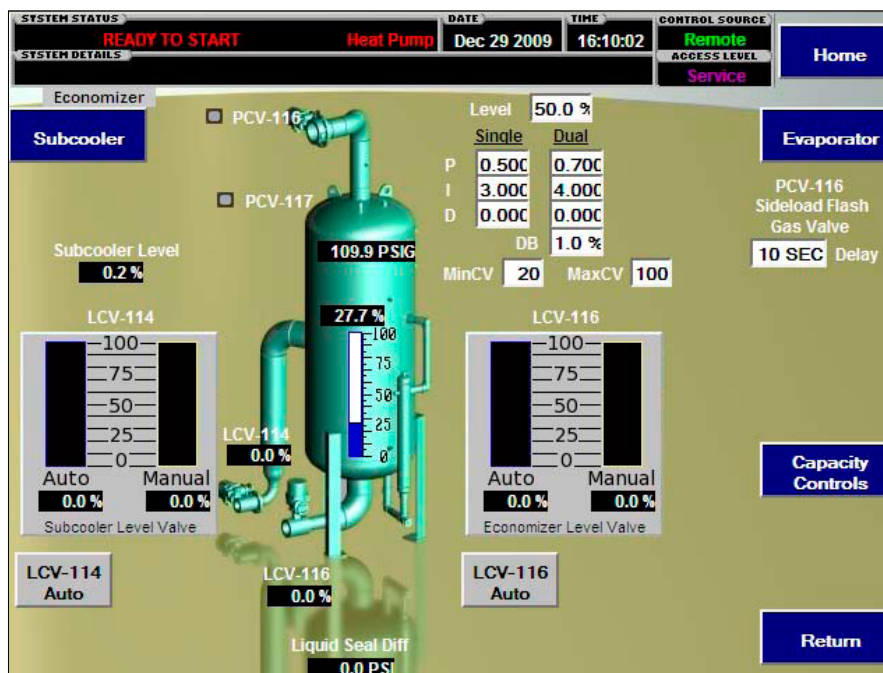

LD15248

FIGURE 73 - ECONOMIZER SCREEN

OVERVIEW

The economizer screen depicts the operation of the economization vessel, which is mounted beside the main heat exchanger vessels. The economizer takes subcooled liquid into its side port from the subcooler level control valve LCV-114. This liquid is decelerated thru a spray-pipe and a vortex breaker. The decelerated liquid is exposed to intermediate interstage pressure. Some small amount of the liquid flashes into a gas, and travels thru the top port (thru an eliminator) and out into the interstage. The remaining liquid travels thru the bottom of the economizer, where its level is controlled by the outlet level control valve LCV-116. This action provides a cycle efficiency improvement by adding flash-gas to the suction of the booster compressor. The level control of the economizer provides a liquid seal between the intermediate gas pressure and the evaporator pressure on the other side of the LCV-116 level control valve. A 40 to 50% level is typical for the economizer vessel level. The level setpoint is not critical, just that the liquid seal is maintained. The LCV-116 level control is available with two sets of tuning parameters, since running in single stage mode and two-stage mode present different running characteristics.

On startup, the economizer level control will override loading the chiller until a sufficient level is attained. The refrigerant management aspect of the economizer must be maintained during normal operation. This prevents slugging liquid into the suction of the compressor.

In single Stage operation the PCV-116 sideload control valve is closed. The PCV-116 sideload control valve is used only during two-stage operation; its purpose is to prevent backspin at shutdown. When the unit goes into a controlled stop, the sideload is closed to prevent pressure from forcing the low stage compressor to spin backwards. The PCV-116 also protects the interstage from slugging liquid, by closing, if a high economizer level occurs.

On startup the PCV-116 valve opening can be delayed by a timer. This timer is programmable from this screen. The time delay in seconds should allow the HS compressor vanes to obtain a reasonably open position before the sideload gas valve is opened. This prevents reverse flow of gas through the sideload line.

PCV-117 is called the BLEED SOLENOID; it is used exclusively in single stage operation. As the gas pressure builds in the top of the economizer vessel, no more liquid can enter the vessel. To maintain a level setpoint during single stage operation, the gas that has expanded in the top of the economizer must be bled off. This valve will open when the LT-116 level sensor is 15% less than setpoint. It will remain open until the level signal raises by 1%, or until its timer times out after 1 minute. It is normal to have this valve open and close occasionally during a single stage run.

Standard Manual-auto stations are provided to take control of any individual valve. The PID controlling the valve will adjust to the manual position upon Manual to Automatic operation transfer.

PROGRAMMABLE

LCV-114 Auto

Access Level Required: OPERATOR

Refer to *Figure 26 on page 55* for operational use.

LCV-116 Auto

Access Level Required: OPERATOR

Refer to *Figure 26 on page 55* for operational use.

NAVIGATION

Home

Used to provide additional Home information.

Evaporator

A detailed view of all evaporator parameters, including the programmable Leaving Chilled Liquid Setpoints.

Capacity Controls

Returns the display to view the Capacity Controls Screen.

Return

Returns the display to the previous screen.

HISTORY SCREEN

SYSTEM STATUS		DATE	TIME	CONTROL SOURCE	
READY TO START		Dec 29 2009	16:01:05	Remote	
SYSTEM DETAILS				ACCESS LEVEL	
				Service	
History					
Safety		Occurred	Cleared		
01	Alarm: HS Motor Current No Run	12-22-09 07:15:10	12-22-09 07:15:24		
02	Alarm: LS Motor Current No Run	12-22-09 07:15:10	12-22-09 07:15:24		
03	Alarm: LS Interlock With No Run	12-22-09 07:15:10	12-22-09 07:15:24		
04	Alarm: HS Interlock With No Run	12-22-09 07:15:10	12-22-09 07:15:24		
05	Trip: R1 Safety Relay Not Set	12-21-09 13:46:46	12-21-09 13:46:50		
06	Alarm: LS Interlock With No Run	12-21-09 11:44:43	12-21-09 13:13:31		
07	Alarm: HS Interlock With No Run	12-21-09 11:44:43	12-21-09 13:13:31		
08	Alarm: HS Motor Current No Run	12-21-09 11:44:41	12-21-09 13:13:31		
09	Alarm: LS Motor Current No Run	12-21-09 11:44:41	12-21-09 13:13:31		
10	Trip: LS Pump Did Not Make Setpoint	12-21-09 11:44:31	12-21-09 13:13:31		
11	Trip: LS Low Oil Pressure	12-21-09 10:21:25	12-21-09 10:43:30		
12	Alarm: LS Low Oil Pressure	12-21-09 10:21:25	12-21-09 10:43:30		
13	Trip: LS Motor Amps Low	12-16-09 09:59:51	12-16-09 14:16:59		
14	Alarm: HS Motor Current No Run	12-16-09 09:55:15	12-16-09 09:55:52		
15	Alarm: LS Motor Current No Run	12-16-09 09:55:15	12-16-09 09:55:52		
16	Alarm: HS Interlock With No Run	12-16-09 09:55:15	12-16-09 09:55:52		
17	Trip: LS Motor Interlock Lost	12-16-09 09:55:04	12-16-09 09:55:52		
18	Trip: LS Motor Starter Fault	12-16-09 09:53:31	12-16-09 09:53:36		
19	Trip: LS Motor Starter Fault	12-16-09 09:52:54	12-16-09 09:53:07		
20	Trip: Emergency Stop	12-16-09 09:51:27	12-16-09 09:51:34		
21	Trip: Emergency Stop	12-16-09 09:51:21	12-16-09 09:51:26		
22	Trip: R1 Safety Relay Not Set	12-16-09 09:50:43	12-16-09 09:51:26		
23	Alarm: HS Motor Current No Run	12-14-09 15:30:56	12-14-09 15:31:18		
24	Alarm: LS Motor Current No Run	12-14-09 15:30:56	12-14-09 15:31:18		

LD15253

FIGURE 74 - HISTORY SCREEN

OVERVIEW

The History Screen provides a comprehensive report of all system alarms and trips. Given are the date and time of the trip or alarm along with a description of each. When an alarm is acknowledged, the system stamps the alarm with the date and time that the particular alarm was acknowledged.

INTERACTIVE

Acknowledge

The acknowledge function key stamps the alarm with the date and time that the alarm occurred. Use the arrow keys to highlight and move between alarm messages. Press the ENTER key when an alarm is highlighted to view the frozen data capture at the time that this alarm occurred. This display as described in the next section is the "Freeze Screen".

NAVIGATION

Return

Returns the display to the previous screen.

FREEZE SCREEN

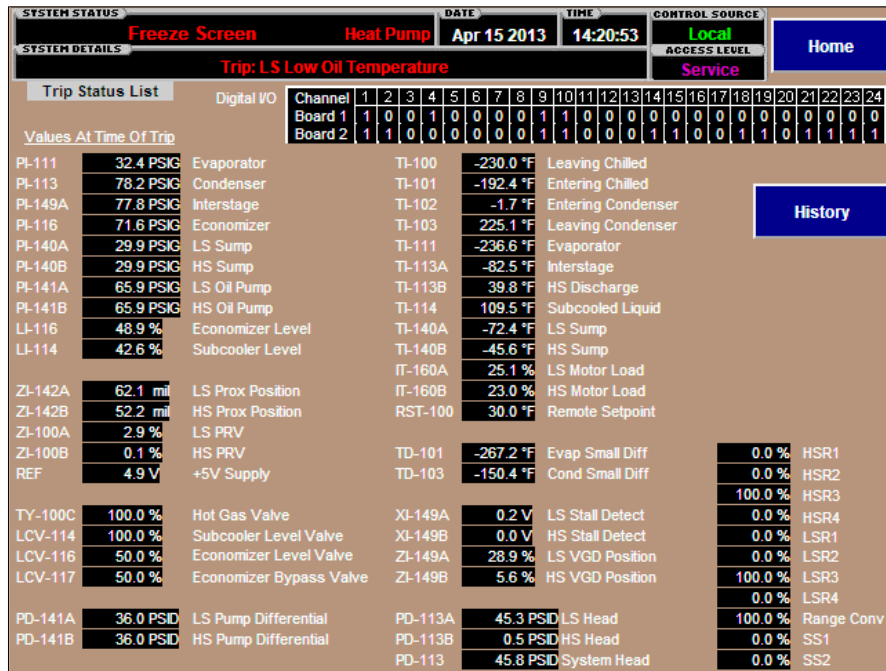

LD15254

FIGURE 75 - FREEZE SCREEN

OVERVIEW

Access a Freeze Screen by highlighting a warning or trip event on the HISTORY screen by using the up and down arrow keys and select the particular event by pressing the [ENTER]  button.

These screens provide lists of various chiller parameters which were recorded at the instant the chiller event that produced a trip.

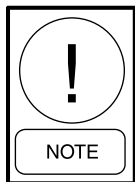

Record desired data prior to updating the Quantum™ LX software.

NAVIGATION

Home

Used to provide additional Home information.

Setup

This screen provides a single location to program the most common system setpoints. It is also the gateway to many of the general system setup parameters such as I/O configuration, Communications Setup, Software Maintenance, Trending, and diagnostics.

History

This screen provides access to a Time stamped Record of shutdown conditions.

TRENDING SCREEN



LD15250

FIGURE 76 - TRENDING SCREEN

OVERVIEW

The Trending Screen provides a setup utility to trend and log data points. The Realtime Trend feature stores data internally to view on a time basis live on the Quantum™ LX. The History Data Log stores the data points in a file that can be transferred off the Quantum™ LX and onto a computer where the data can be stored or analyzed further.

NAVIGATION

Home

Used to provide additional Home information.

Setup

This screen provides a single location to program the most common system setpoints. It is also the gateway to many of the general system setup parameters such as I/O configuration, Communications Setup, Software Maintenance, Trending, and diagnostics.

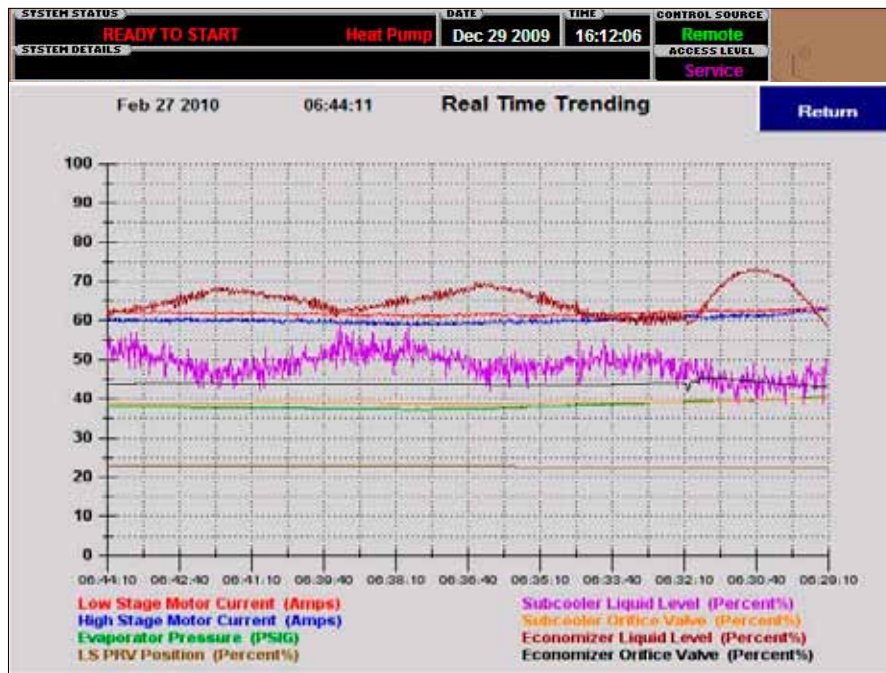

LD15250

FIGURE 77 - REAL TIME TRENDING SCREEN

OVERVIEW

A total of 900 Realtime events can be trended. Real-time events are lost upon each power cycle. The events that can be logged are set using the Trending Setup screen, shown on the previous page.

History trending can save up to 2000 values for each selected channel. History data is stored in Flash memory. Flash memory is non-volatile and all information is retained even if the power to the panel is lost. The interval at which the data is saved can be adjusted. The events that can be logged are set using the Trending Setup screen.

TRENDING SETUP SCREEN

The screenshot shows the Trending Setup screen with the following details:

- SYSTEM STATUS:** READY TO START (Heat Pump)
- DATE:** Dec 29 2009
- TIME:** 16:16:06
- CONTROL SOURCE:** Remote
- ACCESS LEVEL:** Service
- Return** button
- Trending Setup** tab
- Real Time** section:
 - Select Data To Trend: 8 dropdown menus, all set to "Low Stage Motor Current".
 - Recording Interval: 10 SEC
 - Disable Real Time Trending When Chiller Is Off: No
- History** section:
 - Select Data To Trend: 8 dropdown menus, all set to "Low Stage Motor Current".
 - Recording Interval: 1 MIN
 - Disable History Trending When Chiller Is Off: No
- Download Trending Data Files** button

LD15251

FIGURE 78 - TRENDING SETUP SCREEN

OVERVIEW

There are 8 “pens” that can chart data. Touching the pens channel 1 through 8 will allow the user to assign a data point to the “pen”. Select the desired data by scrolling up and down through the list with the touch-screen or with the UP and DOWN arrow keys.

Return to the Trending Screen to select REAL TIME TRENDING to view the trend.

Graphical display of sensor values over the entire period of operation of the chiller. Use the tab  key on the keypad to select between Pens 1 – 8. When a pen has been selected, use the UP and DOWN arrow keys on the keypad to assign the desired sensor to that Pen. Press ENTER to confirm the selection.

Trending Data Files can be downloaded to a USB flash drive for analysis or storage. Insert a USB Flash drive into any USB port on the Quantum™ LX Controller Board, and then press “DOWNLOAD TRENDING DATA FILES” on this screen. The files will be stored in a Comma Separated Variable format for analysis in a spreadsheet software package.

NAVIGATION

Return

Returns the display to the previous screen.

CUSTOM DISPLAY SCREEN

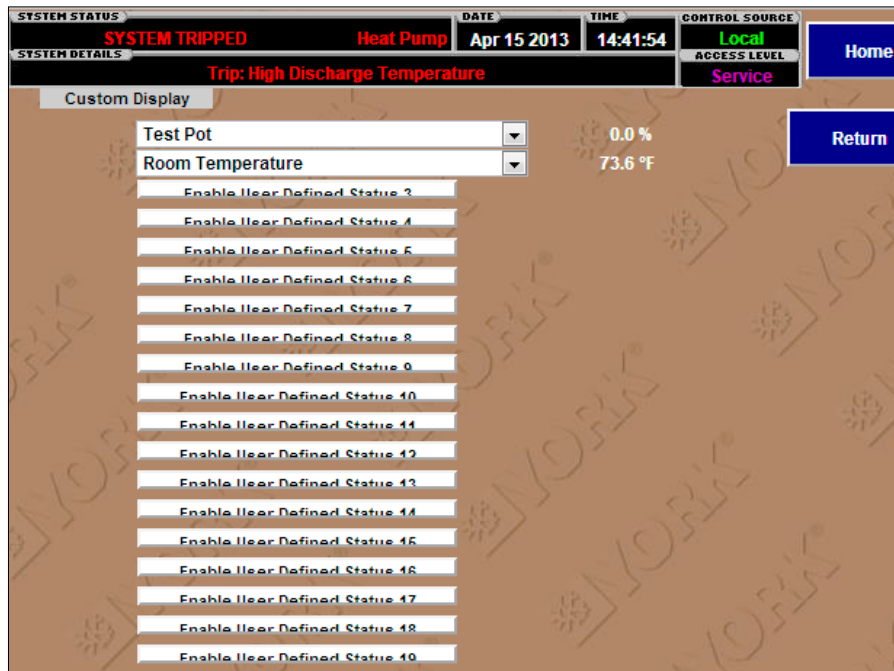

LD15251a

FIGURE 79 - CUSTOM DISPLAY SCREEN

OVERVIEW

The Custom Display page allows access from the View level to set a list of custom analog display items which would not normally be viewable all in one location.

Press the Enable User Defined Status # and then select from the list and press SUBMIT.

THIS PAGE INTENTIONALLY LEFT BLANK

SECTION 4 - SOFTWARE UPDATE PROCEDURE

Access to update the chiller SOFTWARE MAINTENANCE screen is only available on the SETUP screen when the unit is in a standby state. The standby state is defined as when the system is NOT running, and the oil pumps are NOT running. The system can be tripped, or ready to start, but not coasting down.

Receiving The Update Image for Windows XP

The update image can be transmitted by email or by use of an FTP service.

The update will consist of three files:

- *burnit.bat*
- *cf.zip*
- *dd.exe*

1. Place these files in the root C:\ folder on your Windows personal computer.
2. Use Winzip or Windows to extract the *cf.img* file from the *cf.zip* file. (To use Windows XP to extract the *cf.img* file, right click on it and select EXTRACT ALL. Then Type C:\)
3. Insure that the *cf.img* file resides in the C:\ folder on the harddrive
4. Remove any other removable flash media from your computer. There must only be one removable USB "thumb" drive attached when creating the update "thumb" flash drive.
5. Insert your USB flash drive (thumb drive) into your personal computer's USB port.

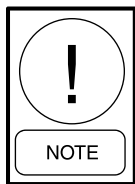

All data on the USB flash drive will be overwritten in this procedure, and it will become unusable to WINDOWS computers. See subsequent section to restore Windows usability of this flash drive.

6. Click on the *burnit.bat* file in Windows Explorer, and a DOS command prompt will open, and the contents of *cf.img* will be written to your USB flash drive (thumb drive). **Be patient as this process can take some time.**
7. When the message appears in the DOS box that you may "Press Any Key to Continue", do so and then remove the USB flash drive safely from the computer.

Receiving The Update Image Windows 7

1. Run the installing program for SELFIMAGE Selfimage may then be run from the Windows "START" button.
2. Assuming that an appropriate compact flash card image is available.
3. When the program is started. The work window is made up of 4 main areas:
 1. The command line including "File Edit Help"
NOTE: This area will need to be used to select the "Start" function on a Windows 7 machine.
 2. The Input area.
 3. The Processing area.
 4. The Output area.
4. The input area should be set to "File" and then using "Input Location" browse to and select the proper Compact Flash card image file.
5. Processing will not need changed when writing a file to a compact flash card. This area can be used if saving a raw or compressed image file from a compact flash card.
6. The Output section is critical. When a USB based compact flash reader is plugged in (Prior to starting Selfimage) it will create a drive name. For example the USB devices icon (bottom right of windows work screen) if left clicked on the "Safely Remove Hardware" will show the name applied to the device. In my example case I have a multi reader that shows E, F, G and I. I know that E is the actual drive name given for the compact flash in my reader.

Selfimage in the Output area when selecting Output Location will present a list of drive specs. Knowing that my actual Compact card is an E: drive I can look down that list and find \Device\Hardisk1 (entire disk). Note that the Hardisk1 is the same for both entries. One line higher refers to Hardisk0 and that would be my main primary drive. This would be a very bad selection to make since it would rewrite my system with the image file. Be very careful to select the correct drive name spec before going any further.

\\Device\Harddisk\Partition1 (E:). That's the wrong selection since it is referring to the partition only.



7. Select the "Start" button. It will ask if you are really sure about the destination and you can cancel or allow it to start programming.

Applying the Software update to the Quantum™ LX

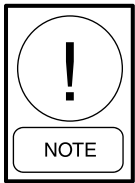
1. Stop the chiller, and allow the postlube cycle to complete.
2. With power ON, insert the USB flash drive (thumb drive) device into any USB port.
3. Enter (at least) User Level 2 (Service) by Pressing LOGIN from the HOME screen.
4. Returns the user to the HOME screen.
5. Navigate to the SETUP screen.
6. Navigate to Software Maintenance.



The touch panel will stop working in the software Maintenance Screen, use the keypad.

7. Press [1] to Save Setpoints.
 - a. Enter any identification number (0 - 99) representing the file number to store your setpoints, in the popup box.
 - b. After entering the number, press the TAB  key and then press the ENTER  key.
8. Press [2] to do a Full System Install.
9. Press [3] to Restore Setpoints.
 - a. Enter the setpoint identification number that was entered in step 7.a)
10. At the conclusion of the Full System Install the Quantum™ LX may ask if you want to do a System Update.
 - a. Reply with YES
11. After the System Update remove the USB thumb drive as instructed and cycle the control panel power.

12. The control application will restart and return to the HOME screen.
13. Check the software version number on the LOGIN screen to see that the system has been updated.

Reclaim USB Flash Drive From Linux Ext Partition

When a USB flash drive is used with the Quantum™ LX, it will be repartitioned to a Linux ext partition type, which is unreadable by Microsoft Windows. Follow the directions below to reclaim the drive to a FAT or FAT32 partition table. This will purge all information from the flash drive. You will need to be an administrator on your Windows PC.

1. Insert the USB flash drive into a port on your computer.
 2. Open the *Disk Management* program by clicking START >> RUN... and typing the following command:
 3. `mmc %systemroot%\system32\diskmgmt.msc`
 4. Press *enter* on your keyboard.
 5. A *Disk Management* window will appear.
 6. There should be more than one disk shown. Select the drive letter of the USB flash drive [for example (E:)]. Highlight this drive letter.
- DO NOT HIGHLIGHT (C:) or all data on your computer will be destroyed**
7. From the menu select ACTION >> ALL TASKS >> DELETE PARTITION
 8. A popup will appear saying that the selected partition was not created by Windows and might contain data recognized by other operating systems. Do you want to delete this partition. Respond **YES**
 9. Re-highlight the removable disk in the bottom of the *Disk Management* window and notice that it is "Unallocated".
 10. From the menu select ACTION >> ALL TASKS >> NEW PARTITION.
 11. A popup wizard will appear, select NEXT, and then select NEXT again to confirm the PRIMARY PARTITION, then select again to confirm the default size.



USB
FLASH
DRIVE

Plug a USB Flash Memory Drive into any one of these USB ports on the bottom of the Main Controller board.

LD15274

FIGURE 80 - USB FLASH DRIVE

12. Assign the drive letter (**E:**) [or other if desired] and select NEXT.
 13. Format the partition with a FAT32 file system, default allocation, and type a volume label (or leave at default), then select NEXT.
 14. Click Finish
 15. Re-highlight the removable disk in the bottom of the *Disk Management* window and notice that it is "FAT32 and Healthy".
 16. From the menu select ACTION >> ALL TASKS >> FORMAT
 17. Type a Volume Label, select FAT32 and use the default allocation size.
 18. Confirm the popup box that appears telling you that all data will be erased on the flash drive with an **OK**.
 19. Close the *Disk Management* program.
- Your USB flash drive is now ready to use with Windows again.

THIS PAGE INTENTIONALLY LEFT BLANK

SECTION 5 - SYSTEM COMMUNICATION AND NETWORKING

ETHERNET AND NETWORKING

YORK Industrial Systems Controls uses Ethernet as the primary method of connecting one or multiple Quantum™ LX panels to a common computer network. In the past, this interconnection would have been done by serial protocol wiring, such as RS-232/422/485. But with the capabilities of today's technology, Ethernet is the quickest and most efficient way of providing this inter connectivity. Whereas the old serial communications methods (RS232, etc.) were slow by today's standards (kilobits per second transmission speed), Ethernet is available in two speeds: 10 Mbps and 100 Mbps.

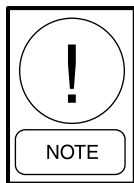

*For connection examples, refer to the section of this manual entitled **Quantum™ LX Local Ethernet Configurations and Quantum™ LX Ethernet Network Configurations**.*

Ethernet is a data and information sharing system. To put it simply, it is a method of connecting one computer to many others on a common network. This network can consist of both hardwired connections, and wireless devices, hence the name ETHERNET. Any Windows or Linux based computer is capable of accessing this network. All that is needed is either a modem, USB port, or an Ethernet port. These devices provide the necessary point of connection for one end (branch) of the connection (a home computer for instance).

The other point that completes the connection is usually provided by an Internet Service Provider (or ISP). The Internet Service Provider usually has a very large network router, or means of bring in many individual connections. The router then assigns a discrete and individual address to each connection (much like a street address). This address is known as an Internet Protocol address (IP). The IP address consists of a series of 4 to 12 digits, and is normally transparent to the end user.

For those individuals familiar with using the internet, they are familiar that every time they activate their web browser (the software that allows your computer to connect), there is an address bar that appears near the top of the screen. This address bar is where you would enter the IP address of the computer or network that you would like to communicate with. To make this simpler, these numeric IP addresses are also coded to allow alpha-numeric names to be masked over them, so that rather than having to enter an address of 216.27.61.137, you can simply enter in www.jci.com, as an example. Although the actual process is more detailed and complicated than this basic explanation, the end result is that most of the work is being done invisibly. The following write up describes how to set up the Quantum™ LX to do this behind the scenes work, so that it can communicate both at the Internet level, and at a local Ethernet level.

CONNECT TO
LAN 1 FOR
ETHERNET
COMMUNICATIONS



Bottom view of Quantum™ LX controller board

LD15274a

FIGURE 81 - ETHERNET CONNECTION

Cabling

Each Quantum™ LX Ethernet connection must be individually cabled (known as a homerun) direct from a switch or computer. Unlike RS422/485 communications which allowed for cable daisy chaining, Ethernet connections do not allow this. This type of cabling is designed to handle the 100- Mbps speed needed by Ethernet. Both ends of each cable must have an RJ-45 connector attached. The RJ-45 connector looks similar to the RJ-11 connector on the end of a telephone cord but is slightly larger (and not compatible). You can buy Cat 5 cables in predetermined lengths with the connectors already attached (for short runs), or you can buy the cable in rolls, cut it to length and install the RJ-45 connectors to the ends (up to 100 meters per each cable run). Although it is recommended to use shielded, twisted pair Cat 5 cable, if the cable is not properly constructed and tested, it can actually be more detrimental to the network than unshielded cable. As long as all of the cables that are used have been properly constructed AND tested, either shielded or unshielded are acceptable. This is mostly due to the excellent (electrical) noise immunity that is inherent with Ethernet components.

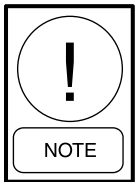

Follow standard networking procedures for the interconnections of all components. For individual cable runs in excess of 300 feet (~100 meters), a Switch/ Hub must be used for each additional run.

Cabling Do's and Don'ts –

It is recommended to follow these guidelines when installing and using CAT 5 Ethernet cable:

- Do run all cables in a star (homerun) configuration.
- Do keep all individual cable lengths under 300 feet. If greater distances are needed, use a switch/hub every 300 feet.
- Do ensure that the twists of the wire pairs within the cable are maintained from end to end.
- Do make gradual bends in the cable. Keep each bend radius over one inch.
- Do keep all cables tie wrapped neatly.
- Do try to maintain parallel cable runs where possible.
- Do keep the cable as far away as possible from EMI sources (motors, transformers, solenoids, lighting, etc.)

- Do label the ends of each cable, to facility troubleshooting and identifying in the future.
- Do test each individual cable run with an approved CAT5 E cable tester. A TONING alone test is NOT acceptable.
- Do use rubber grommets anywhere that the cable enters through a hole in a metal panel.
- ALWAYS obey local, national and fire building codes.

The following are things that should NOT be done when installing and using CAT 5 Ethernet cable:

- Don't install cable taut, cables must always have some "play" or slack in them.
- Don't over-tighten cable ties.
- Don't splice a cable. If a break occurs, or the length is not long enough (under 300 feet), replace the entire run with an intact length.
- Don't tie cables to electrical conduits.
- Don't strip more than one inch from the end of each cable when installing end connectors.
- Don't sharply bend or kink the cable.
- Don't mix 568A and 568B wiring at the same installation. 568B is the most common wiring.
- Don't use excessive force when pulling cable.

RJ-45 Connectors

Ethernet network cables require the use of industry standard RJ-45 plugs as shown below, for the termination of all cables:



LD15276

FIGURE 82 - TYPICAL RJ-45 CONNECTOR

When looking at this connector, pin 1 is at the left, and pin 8 is at the right.

The Hub

A Hub is a common connection point for devices in a network. Hubs are commonly used to connect segments of a LAN (Local Area Network). They also contain multiple ports. When a data packet arrives at one port, it is copied to the other ports so that all segments of the LAN can see all packets.

The Switch

Network Switches look nearly identical to hubs, but a switch generally contains more intelligence than a hub. Unlike hubs, network switches are capable of inspecting the data packets as they are received, determining the source and destination device of a packet, and forwarding that packet appropriately. By delivering messages only to the connected device that it was intended for, network switches conserve network bandwidth and offer generally better performance than hubs.

The Switch takes the signal from each computer/Quantum™ LX and sends it to all of the other computers/LX panels in your plant or office. Switches come in several sizes, noted by the number of ports available -- a four-port Switch can connect four computers, an eight-port Switch can connect up to eight computers and so on.

So, if you start with a four-port Switch but eventually add more panels, you can buy another Switch and connect it to the one you already have, increasing the potential number of panels on your network.



FIGURE 84 - TYPICAL SWITCH

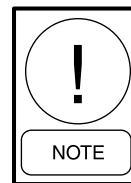

If you want to connect one computer to one Quantum™ LX, you can avoid the switch and use a crossover Cat 5 cable. With a crossover cable, you directly connect one Ethernet device to the other without a Switch. To connect more than two you need a Switch.

5

Refer to the following pictorial to construct a crossover cable:

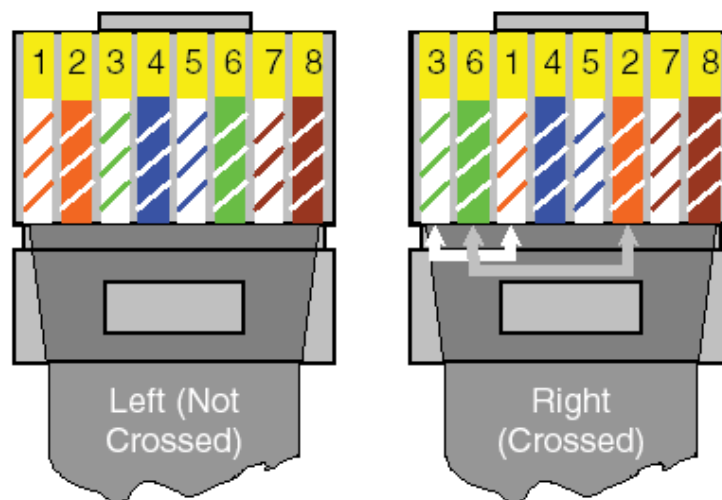

BOTH ENDS OF A CROSSOVER CABLE

FIGURE 83 - CROSSOVER CABLE

Cat-5 Ethernet Cable Color Codes

- 1 – White w/orange stripe 5 – White w/blue stripe
 2 – Orange w/white stripe 6 – Green w/white stripe
 3 – White w/green stripe 7 – White w/brown stripe
 4 – Blue w/white stripe 8 – Brown w/white stripe

Because of the large number of possible configurations in an Ethernet network, you most likely will not have any type of automated installation software. This means that you will need to manually configure all the options. To configure these options for the Quantum™ LX, please refer to Ethernet Setup on the next page.

TABLE 11 - ETHERNET COMPONENT RECOMMENDATIONS

COMPONENT	DESCRIPTION	PART NUMBER	MANUFACTURER
Cable	Shielded solid 4-pair* (1000 Ft)	BOXCAT5E-DSSO	Cablesforless.com
	Shielded solid 4- pair*	E-PLG-SOLID-SH	VPI
		CR45-100S	Cables Direct
		9504 CS	Alpha Wire Co.
		9504 F	
	Un-shielded solid 4-pair**	E-PLG-SOLID	VPI
	Un-shielded solid 4-pair** (1000 Ft)	345U5-1000BLK	Ram Electronics
		0-5EPCS-BK	Computercablestore.com
Crimp Tool	RJ-45 Crimp Tool	HT-210C	Cablesforless.com
		P-15027	Stonewall Cable, Inc.
		S2307692	Computers4sure.com
		10-RJ1145	Computercablestore.com
Connectors	RJ-45 For Shielded 4-pair solid wire cable	P-15007	Stonewall Cable, Inc.
	RJ-45 For Un-shielded 4-pair solid wire cable	5-554169-3	Tyco Electronics
		1-5E45-010	Computercablestore.com
		P-15029	Stonewall Cable, Inc.
Cable Tester	Ethernet Cable Tester - Continuity only	TST-5150	Cablesforless.com
	Complete Cable I/O Qualification Tester	N/A	Fluke
Switches	5 RJ-45 port	SFN-5TX	Phoenix
	7 RJ-45 Port and 1 ST Fiber Optic Port	SFN-7TX/FX ST	Phoenix
	8 RJ-45 port	SFN-8TX	Phoenix

*STP = Shielded Twisted Pair

**UTP = Unshielded Twisted Pair

Ethernet Setup

Once all of the cabling has been run and all connections have been made, it is now necessary to setup the Quantum™ LX software to recognize and handle the Ethernet connection.

The following section describes the suggested panel setup for connecting the Quantum™ LX panel to an existing Ethernet connection:

IP DATA

Address Type – The following drop-down menu is provided:

Fixed (Static) – A fixed address is usually assigned by the network (LAN) administrator, and is normally always the same.

DHCP (Dynamic) – Dynamic Host Configuration Protocol permits autoassignment of temporary IP addresses for new devices connecting to the network.

IP Address – (Internet Protocol) Four setpoint boxes are provided here. Every device on an Internet or Ethernet network must be assigned a unique identifying number, called an IP Address (this is similar in concept to the Quantum™ LX panel ID number). The IP address is how the network identifies each device that is attached. A typical IP address would look like this: 216.27.61.137

Gateway Address – Four setpoint boxes are provided here. This is the IP address for the computer or device onto which your local network is connected to. This gateway device is how all of the devices attached to your local network are routed to other gateways and networks. A router is a Gateway device that routes packets between different physical networks. A gateway is a network point that acts as an entrance to another network.

HOME --> SETUP --> ETHERNET

LD15258a

FIGURE 85 - ETHERNET SETUP

Subnet Mask – A TCP/IP number used to determine to which TCP/IP subnet a device belongs. Devices in the same subnet can be communicated with locally without going through a router (to the outside world). When a TCP/IP device tries to communicate with another device the bits of the TCP/IP destination address are "ANDed" with the subnet mask to determine whether the address is a local address (broadcastable) or must be reached through a router. A subnet mask of 255.255.255.0 used by a computer with a TCP/IP address of 10.10.10.1 would include the addresses 10.10.10.0 through 10.10.10.255 in the local network, basically telling the computer to try a router if it's transmitting to any other IP address. This is all part of the TCP/IP protocol.

Web Server Port – This is the port, or channel, that a web server uses to communicate through. Just as a computer sends data to a printer through a printer port, a web server sends and receives data through the Web Server Port. By default, the port number for a Web server is 80.

Naming Data

Host Name – Enter a distinct name that you wish to be able to identify this particular compressor by (for example; Unit1). The Host Name must be fifteen characters or less in length, use no spaces and use only upper and lower case letters. It is similar in concept to the function of the Panel ID, and basically allows the network router to interpret the actual IP address of a particular unit as this host name. When using a web browser within the system network, this name can be entered as the web location that you wish to visit (instead of having to type in the IP address). After modifying a Host Name, you will be required to cycle power. The network router could take up to fifteen minutes to recognize the change.

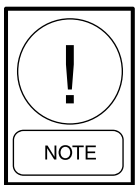

The IP Address Type must be set to DHCP (Dynamic) for this section to work.

Work Group – All of the Quantum™ LX units within a network may be grouped into different categories. These categories could be unit locations, or perhaps categorized by unit function. For instance, if you wanted to group the units by function, and had 10 units, and three of them were Evaporators (located on the roof), then Evap1 could be the name of a work group. Another three units may be Heat Pump Units, this work

group could be named Heat Pump 1, and the remaining four units could be standard chillers, and they could be named Chiller1. So name each unit by these functional Work Group names. The Work Group name must be fifteen characters or less in length, and can use numerals and upper and lower case letters. When using the network neighborhood feature of Windows® Explorer, by looking at your Network Neighborhood, you would see the name of the Work Group, and within that work group you would see the individual Host Names of each unit within that work group. After modifying a Work Group name, you will be required to cycle power. The network router could take up to fifteen minutes to recognize the change.

Server String – This is a comment area that can be used in conjunction with the Host Name. For example, if the Host Name is Plant1, you could set the Server String to print something like EastPlant, or some other additional information about the unit. The Server String has no control function; it is strictly an informational area.

E-Mail Data

The purpose of the E-Mail data feature is to allow the controller to send a Warning or Shutdown message to defined listing of recipients.

Email Notification On Warning Or Shutdown – For the E-mail notification feature to work, it must be enabled (it is disabled as a default). The following drop-down menu is provided:

- Disabled
- Enabled

Local Email Address – Use this setpoint box to enter a valid E-mail address that has been assigned to the internet account.

Alias Name For Local Email Address – Enter here a custom name to identify more clearly the local Email address. When a message is sent to all recipients, this is the name that will appear in the Email FROM column.

Subject – Enter a custom subject that you would like to appear when a message failure is sent. When a message is sent to all recipients, this is the wording that will appear in the Email SUBJECT column.

SMTP Server Name OR IP Address – SMTP stands for Simple Mail Transfer Protocol. SMTP servers handle outgoing email, and accept email from other domains. When you set up an email client, you must specify an outgoing server (sometimes called an SMTP server).

Often, this server is designated in the form of smtp.domain.com. But this can vary, so be sure to check with your email service provider or LAN administrator to find out their outgoing server.

SMTP Server Port Number – This value is in almost all cases going to be 25. This should be set by the network or LAN administrator. **Comma-Delimited List Of Email Recipients** - This is simply the list of the Email addresses that you would like to have any messages sent to. Separate each email address with a comma.

SMTP Authentication for Email Data – Emails can be sent when the Quantum sets an alarm.

Protocols

The purpose of this section is to enable or disable the Modbus TCP and Ethernet/IP parameters.

- Modbus TCP:
 - Disabled
 - Enabled
- Ethernet/IP:
 - Disabled
 - Enabled

SERIAL COMMUNICATIONS

General Description

Serial communications to and from the Quantum™ LX uses RS-232 or RS-485 hardware protocol depending on the specific Com port.

The Com-4 serial communications port is configured for RS-485 and is connected directly to the I/O boards. Com-1 is located at the bottom left of the controller board.

The Com-1 port is not used.

The Com-2 port is the programmable **Serial Slave Communication Port** on the Serial Setup screen. It is an RS-232 port and can be used to communicate to an external supervisory system or networking gateway device.

The Com-3 port is reserved for the optional Liquid Cooled Solid State Starter Modbus Master Communication Port.

RS-232 Description

RS-232 is by far the most common (and oldest) serial communications hardware protocol, as almost all laptop and desktop computers will have at least one RS-232

serial communications port available. It was initially developed for the emerging computer industry in the 1960's. Originally, it was a method of sending data from a mini or main frame computer, to devices such as printers, punch card readers, teletypes, magnetic tape units and modems. In those early days, the maximum speed at which RS-232 was capable of transmitting (about 9600 bits per second), was quite satisfactory, as most of the receiving devices were mechanical in nature (except for modems), and barely able to keep up with these speeds.

RS-232 uses single ended TX (transmit data) and RX (receive data). This means a common ground wire is shared between TX and RX, so only 3 wires are needed or a data only serial channel: TX, RX, and GND.

Disadvantages of single ended signaling is that it is more susceptible to noise than differential signaling (RS-422/485), effective cable distances are shorter (typically about 50 Ft. total, due to low noise immunity) and data rates are slower. Additionally, there is the limitation that only two devices can communicate together (master and slave).

The Quantum™ controller has one RS-232 port available. Com-3 attached to the RedLion Data Station provides the communication link to Building Automation System or DCS.

RS-485 Description

When serial communications started moving into the industrial environment, it was quickly noted that because of the high electrical noise potential from electric motors, valves, solenoids, fluorescent lighting, etc., that the noise immunity characteristics of RS-232 protocol was grossly lacking. Additionally, the distances between the communicating equipment on the factory floor was much greater than that within the typical office environment. For these reasons, RS-485 was developed.

RS-485 is a half duplex bus. This means that it can only send data, or receive data at any given time. It cannot do both at the same time. The Quantum™ LX uses a 2-wire system for RS-485 (one positive transmit/receive wire and one negative transmit/receive wire). Up to 30 Quantum™ LX controllers may be simultaneously connected up to a total distance of 2000 ft. using a daisychain wiring scheme (to be explained later). One advantage to using RS-485 as opposed to RS-422 is that only a single twisted pair cable need to be run to all devices (while RS-422 requires a double twisted pair cable), much greater noise immunity than RS-232. RS-422/RS-485 signals cannot be connected directly to an RS-232 device.

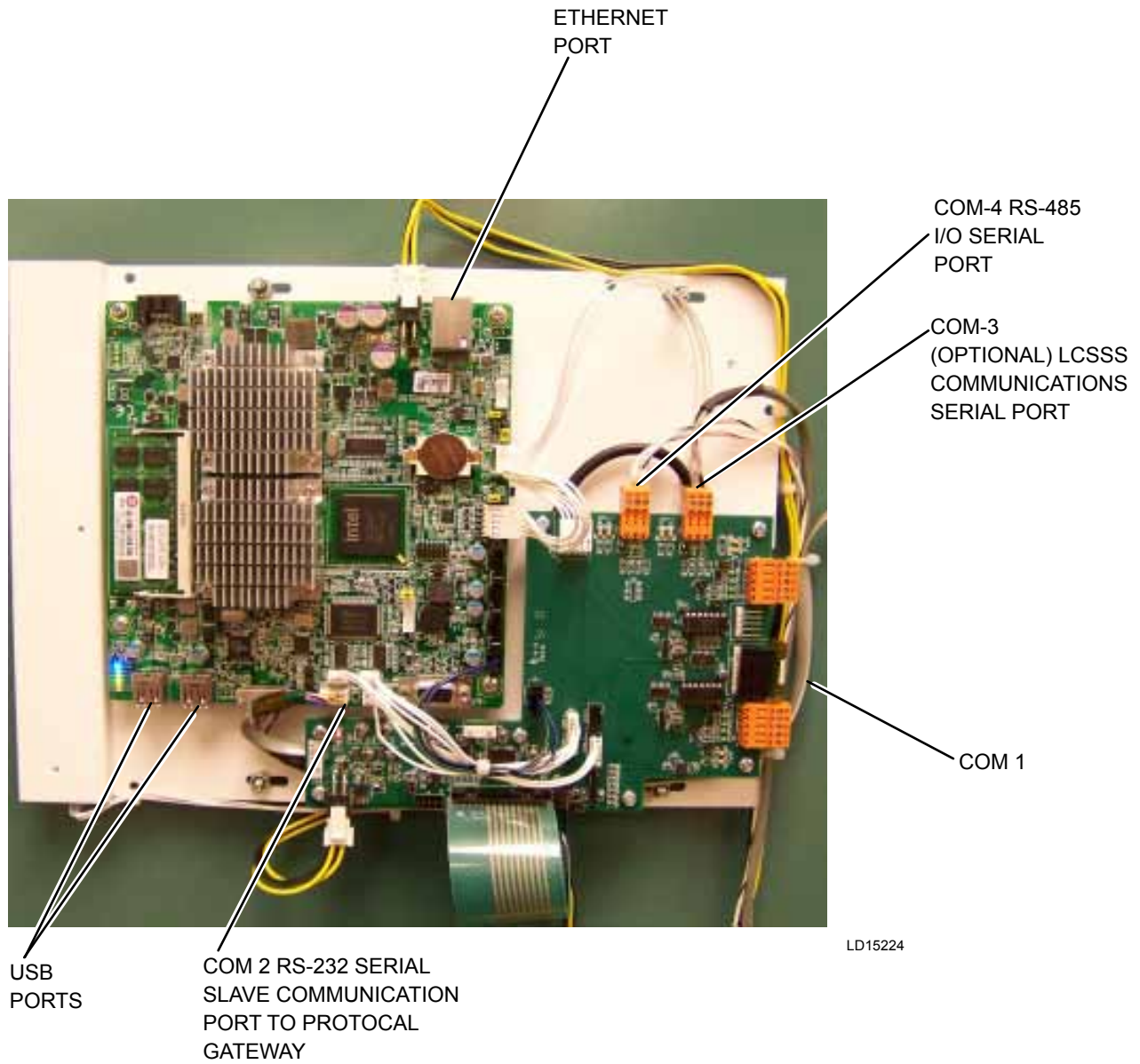

FIGURE 86 - SERIAL PORT LOCATIONS

Serial Communications Setup

After the serial communications wiring has been connected, and jumpers correctly set, the LX software needs to be setup to match that of the device(s) that it is to communicate with. The following screen is where this information can be found:

The following setpoints are provided:

Compressor ID – A number that is used by an external communications application, to converse to individual compressors. On interconnected systems, this number must be unique. Valid values are from 1 – 99.

Status – Shows the current communications status of the port. The possible messages are:

Off – No communications are currently taking place.

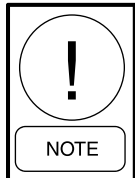

A delay of 15 seconds or more of inactive communications (time between valid responses) will cause this message to display.

Active – Valid communications are actively occurring.

Failed – An invalid command was received by the port. This could be due to a bad checksum value, a wiring issue, or hardware problem at either the transmitting (host) or receiving (Quantum™ LX) end.

Baud Rate – The baud rate defines the speed at which external communications can occur. The higher the baud rate, the faster the communications. It is best to start out using a lower baud rate, and increasing the value only after verifying that communications errors do not occur. If errors start to occur, drop the baud rate back down. A pull down menu is provided to select from the following:

- 1200
- 2400
- 4800
- 9600
- 19200
- 38400
- 57600
- 115200

5



HOME >> SETUP >> SERIAL COMMUNICATIONS

LD15259

FIGURE 87 - COMMUNICATIONS SETUP

Data Bits – Determines the number of bits in a transmitted data package. A pull down menu is provided to select from the following:

- 7
- 8

Stop Bits – A bit(s) which signals the end of a unit of transmission on a serial line. A pull down menu is provided to select from the following:

- 1
- 2

Parity – In communications, parity checking refers to the use of parity bits to check that data has been transmitted accurately. The parity bit is added to every data unit (typically seven or eight data bits) that are transmitted. The parity bit for each unit is set so that all bytes have either an odd number or an even number of

set bits. Parity checking is the most basic form of error detection in communications. A pull down menu is provided to select from the following:

- None
- Even
- Odd

Protocol – A protocol is the special set of rules that each end of a communications connection use when they communicate. A pull down menu is provided to select from the following Quantum™ LX recognized protocols:

- None
- ModBus ASCII
- ModBus RTU
- AB DF1 Full Duplex
- AB DF1 Half Duplex

Use the following form to record all settings:

TABLE 12 - SERIAL COMMUNICATION SETUP

COMPRESSOR ID	_____ (0 - 255)	
	Com 1	Com 3
Baud Rate		<input type="checkbox"/> 1200 <input type="checkbox"/> 2400 <input type="checkbox"/> 4800 <input type="checkbox"/> 9600 <input type="checkbox"/> 19200 <input type="checkbox"/> 38400 <input type="checkbox"/> 57600 <input type="checkbox"/> 115200
Data Bits		<input type="checkbox"/> 7 <input type="checkbox"/> 8
Stop Bits		<input type="checkbox"/> 1 <input type="checkbox"/> 2
Parity		<input type="checkbox"/> None <input type="checkbox"/> Even <input type="checkbox"/> Odd
Protocol		<input type="checkbox"/> None <input type="checkbox"/> Modbus ASCII <input type="checkbox"/> Modbus RTU <input type="checkbox"/> AB DF1 Full Duplex <input type="checkbox"/> AB DF1 Half Duplex

Serial Communications Port Wiring

COM-2

The following pictorial shows the communications board, as well as the jumpers, LED's and signal pinouts to allow the end user to communicate to Com-2 using RS-232 protocol.

On the Communications Setup screen, verify that the proper Panel ID, Baud rate, data bits, and protocol has been setup at the Quantum™ LX, and matches that of the initiating device.

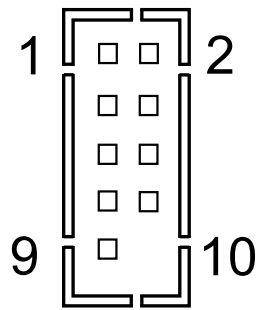

LD15236

TABLE 13 - COMMUNICATIONS BOARD

PIN	SIGNAL	DESCRIPTION
1	DCD	Data Carry Detect
2	SIN	Serial In or Receive Data
3	SOUT	Serial Out or Transmit Data
4	DTR	Data Terminal Ready
5	GND	Ground
6	DSR	Data Set Ready
7	RTS	Request To Send
8	CTS	Clear To Send
9	VCC_ COM	Power Source

Communications Data Logging Screens

DESCRIPTION: This screen allows the technician to view the status of all serial communications ports.

The following user selectable buttons are provided:

- [Show Comm1]
- [Show Comm2]
- [Show Comm3]
- [Show Comm4]
- [Modbus TCP]

This screen allows the technician to view all of the serial communications information that the Quantum™ LX is receiving and transmitting, one port at a time.

Simply select the button at the upper right side of the screen that corresponds to the port that you wish to view. The selected port name (in this case Comm4) will appear in the upper left side of the screen. Each time a new command is sent or received, the screen will need to be refreshed by selecting the [Show Comm X] button (where X is replaced with the comm port number). The top line of data is the most recent activity. At the left of each line, you should see whether the data is IN or OUT (Receive or Send), and the actual data (in Hexadecimal format). This information can be used to compare against the data being sent and received at the other end of the communications link, to verify proper operation. Refer to the section on Hyperterminal for some examples of how this screen may be used.

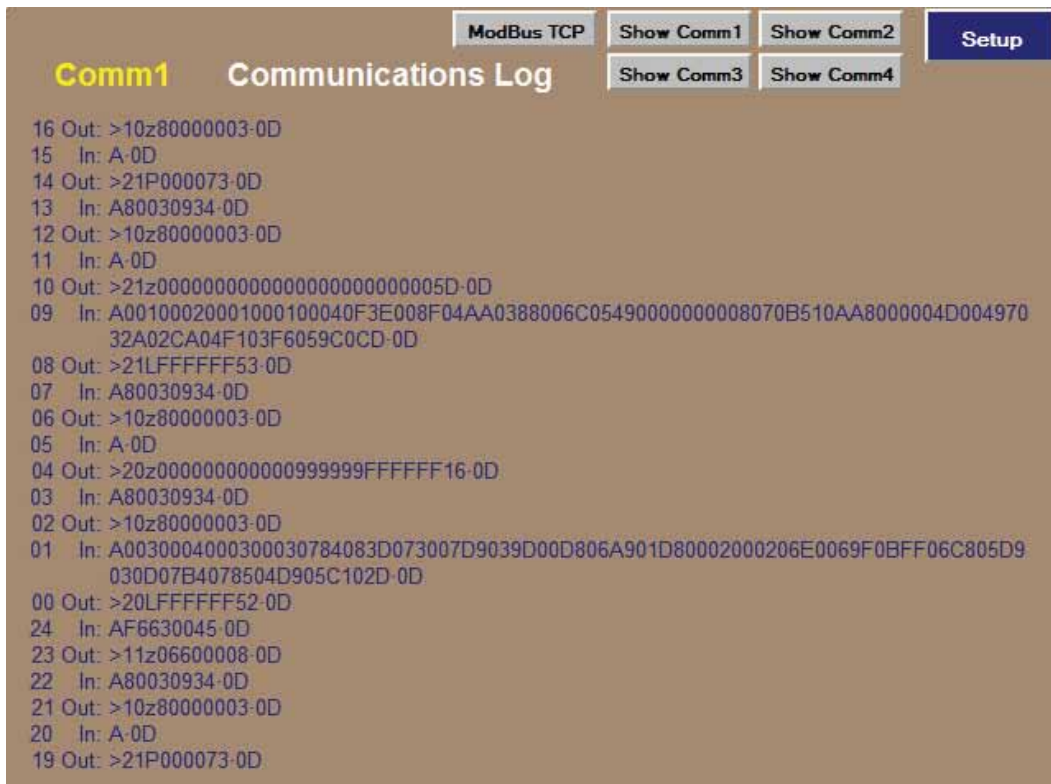

HOME >> SETUP >> DIAGNOSTICS >> COMMUNICATION LOGS

LD15282

FIGURE 88 - COMMUNICATIONS DATA LOGGING SCREENS

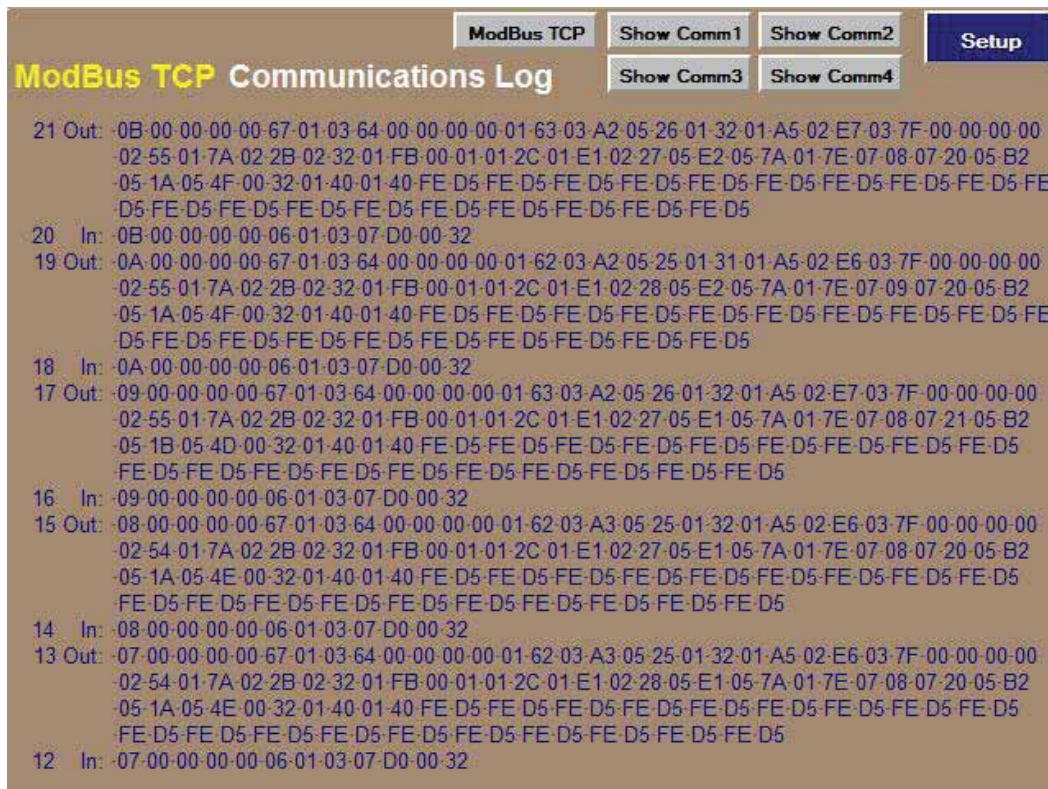

LD15284

FIGURE 89 - MODBUS TCP COMMUNICATIONS LOG

This screen allows the technician to view the ModBus TCP data communications information that the Quantum™ LX is receiving and transmitting. Each time a new command is sent or received, the screen will need to be refreshed by selecting the [Refresh] button, as described earlier. The top line of data is the most recent activity. At the left of each line, you should see whether the data is IN or OUT (Response or Command), and

the actual data (in Hexadecimal format). This information can be used to compare against the data being sent and received at the other end of the communications link, to verify proper operation.

At the bottom of this page is an example for a breakdown of how the data packets are created, using the data that has been shown on the above screen

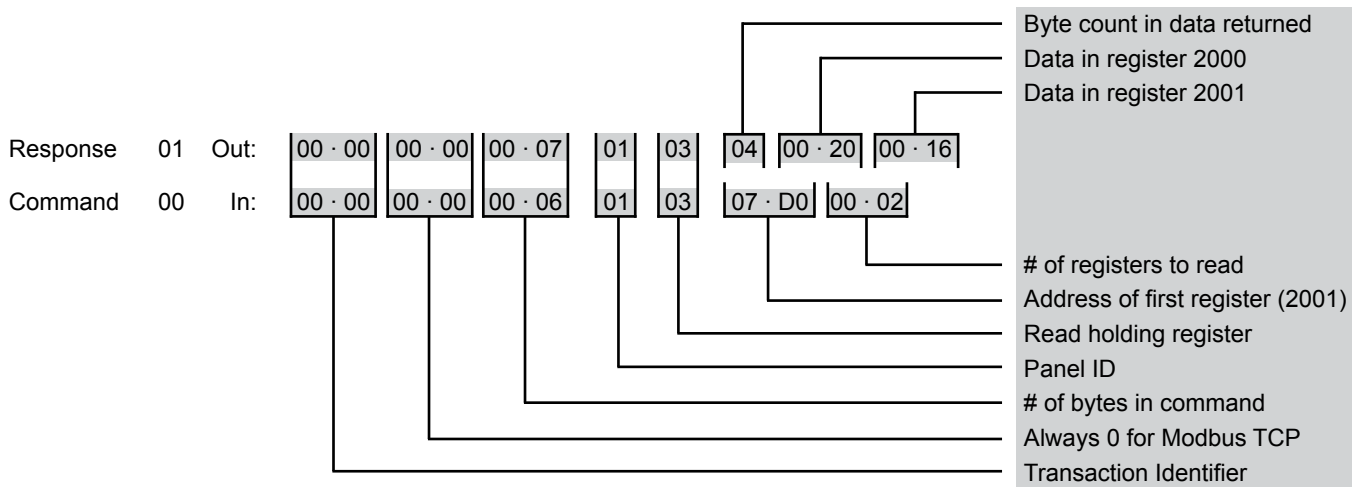

FIGURE 90 - HOW THE DATA PACKETS ARE CREATED

NETWORK INTERFACE PROTOCOLS

The Quantum™ LX for CYK supports the following protocols internally:

- ModBus ASCII
- ModBus RTU
- AB DF1 Full Duplex
- AB DF1 Half Duplex
- Modbus TCP over Ethernet
- Ethernet Industrial Protocol with Allen-Bradley data table structures

Additional protocols and media are supported by the RedLion Data Station Plus.

Please refer to Red Lion Controls publication 07036 DSPLE for configuring and interfacing to the RLC Data Station Plus.

<http://www.redlion.net/Products/Groups/DataStationPlus/DataStationPlus/Docs/07038.pdf>

Data Station Pinout

RLC Crimson 3.0 configuration software can be downloaded here.

<http://www.redlion.net/Support/Downloads/SoftwareLibrary/Crimson3.html>

See the CYK protocol list document in the chiller IOM.

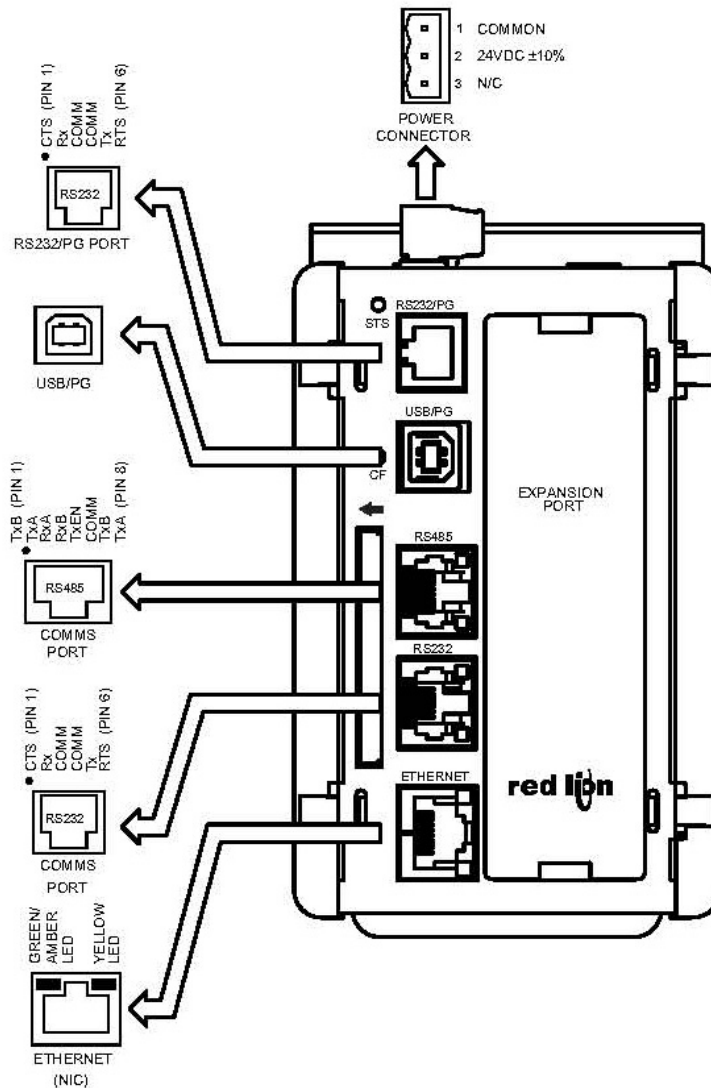

FIGURE 91 - DATA STATION PINOUT

LD15297

QUANTUM LX FOR CYK PROTOCOL LIST

Example Hookups

Connecting the Quantum LX Industrial Control Center to an existing network can be done in many ways. Here are a few examples.

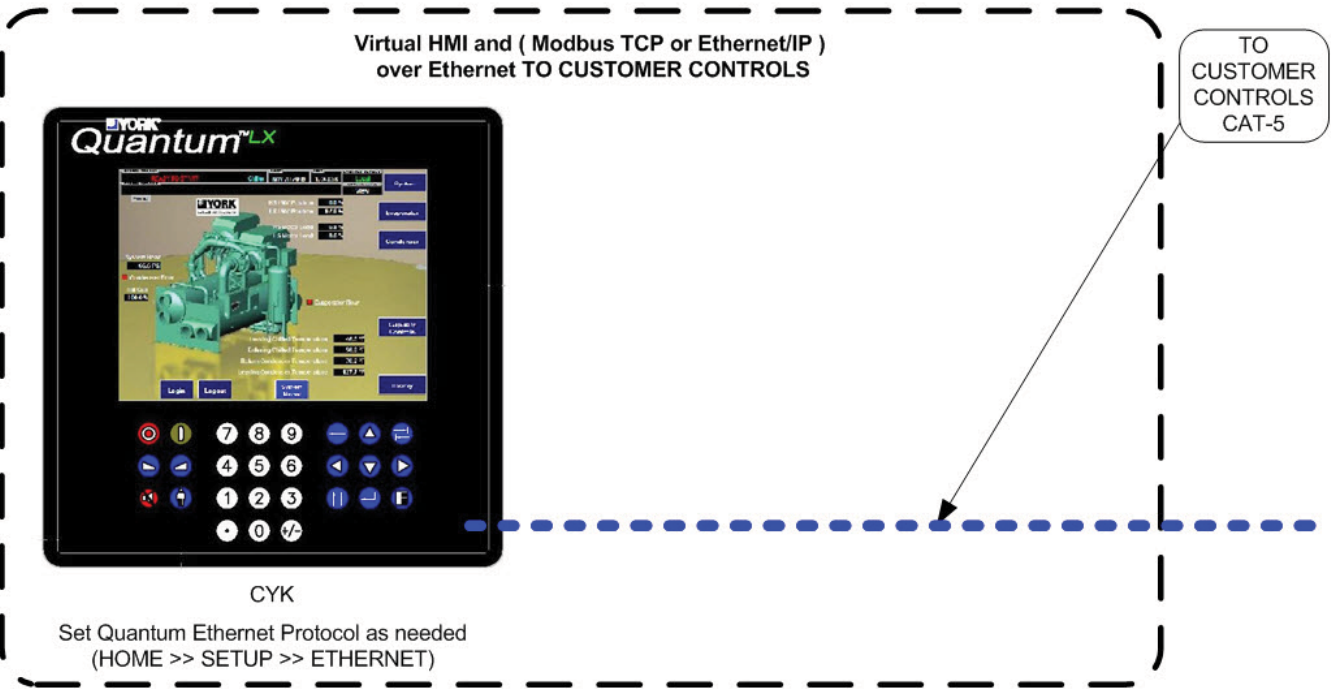

5

LD16258

FIGURE 92 - VIRTUAL HMI

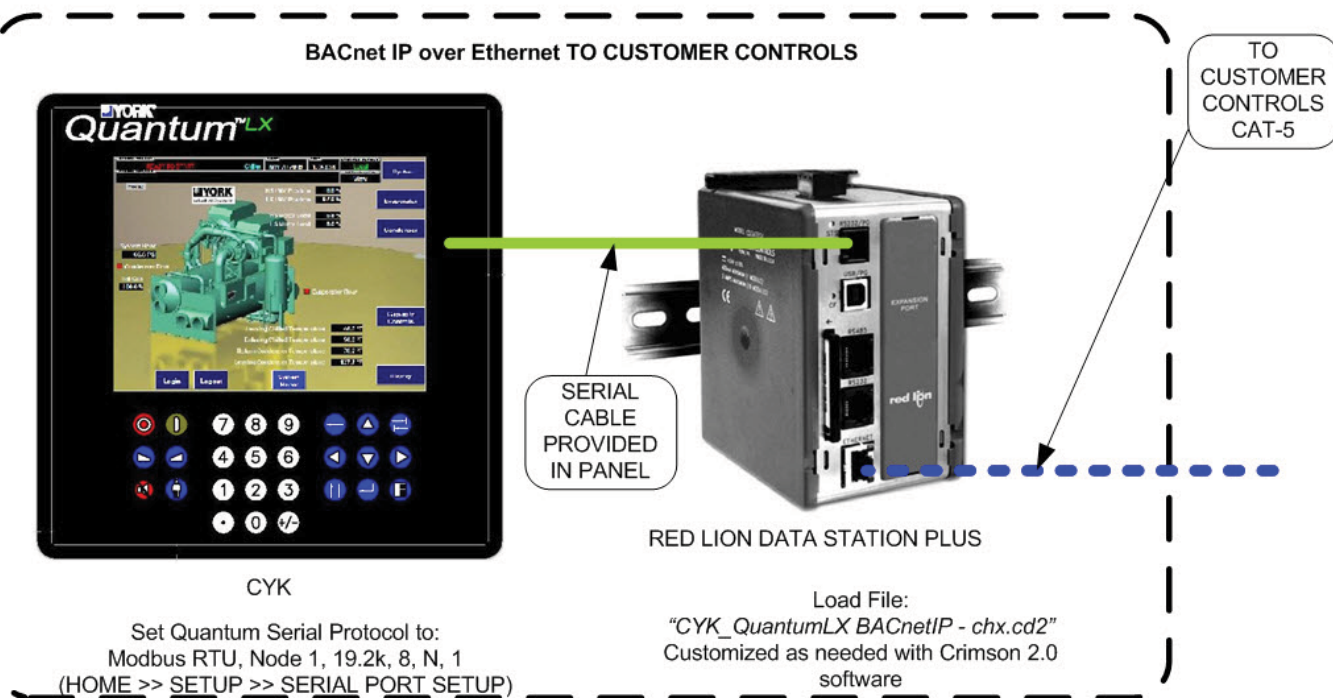

LD16259

FIGURE 93 - BACNET IP OVER ETHERNET

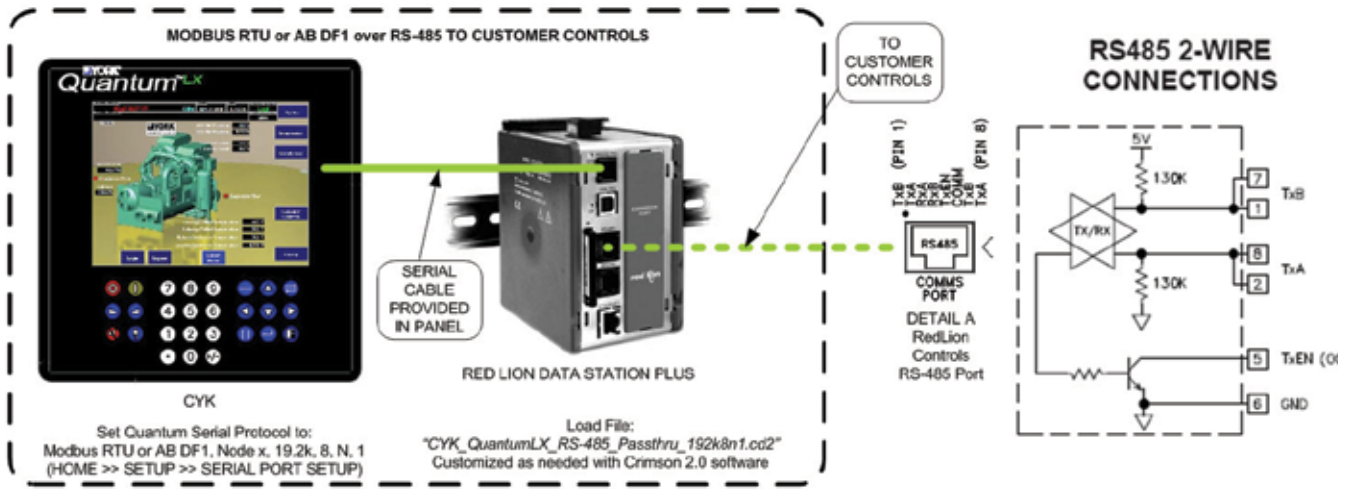
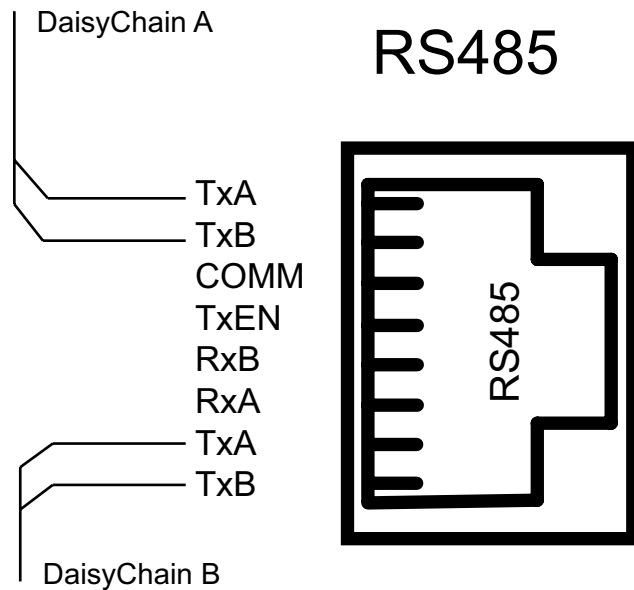

FIGURE 94 - BACNET MSTP OVER RS-485

Use an RJ-45 connector. Pinout references the JACK. A cut-off Ethernet patchcord connector makes a suitable cable.



LD16261

FIGURE 95 - RJ-45 CONNECTOR

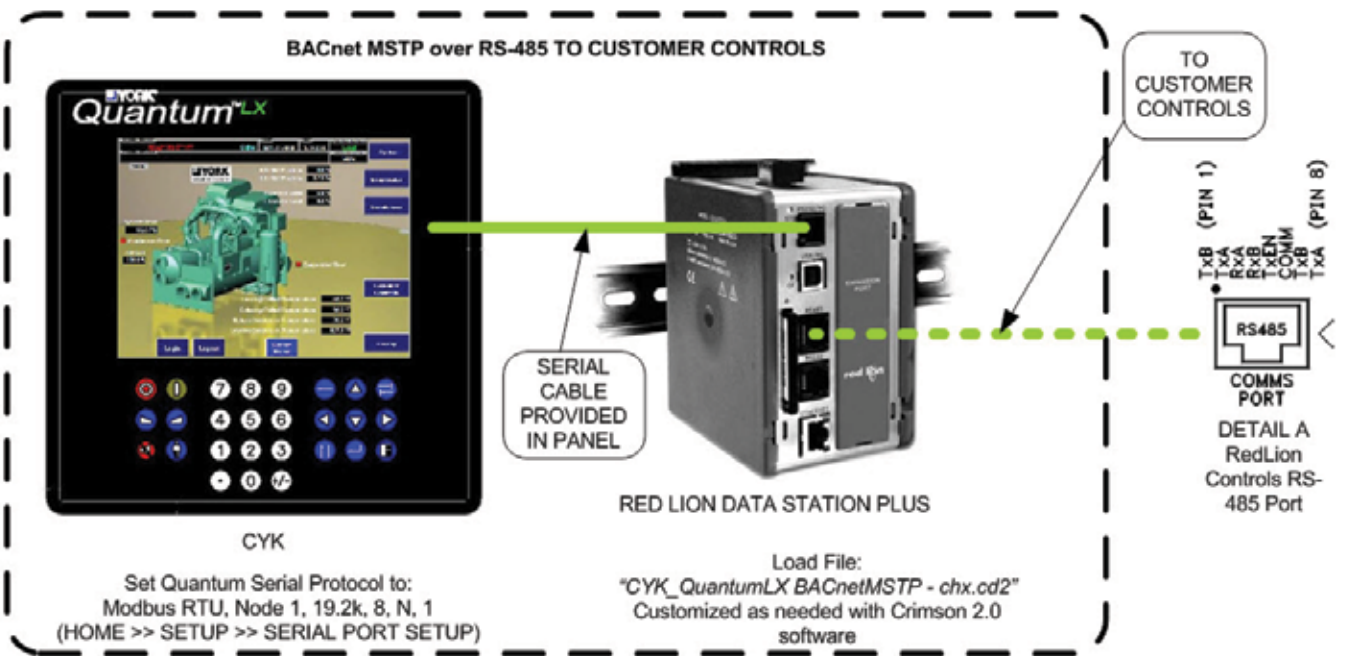

LD16262

FIGURE 96 - MODBUS RTU OR AB DF1 OVER RS-485

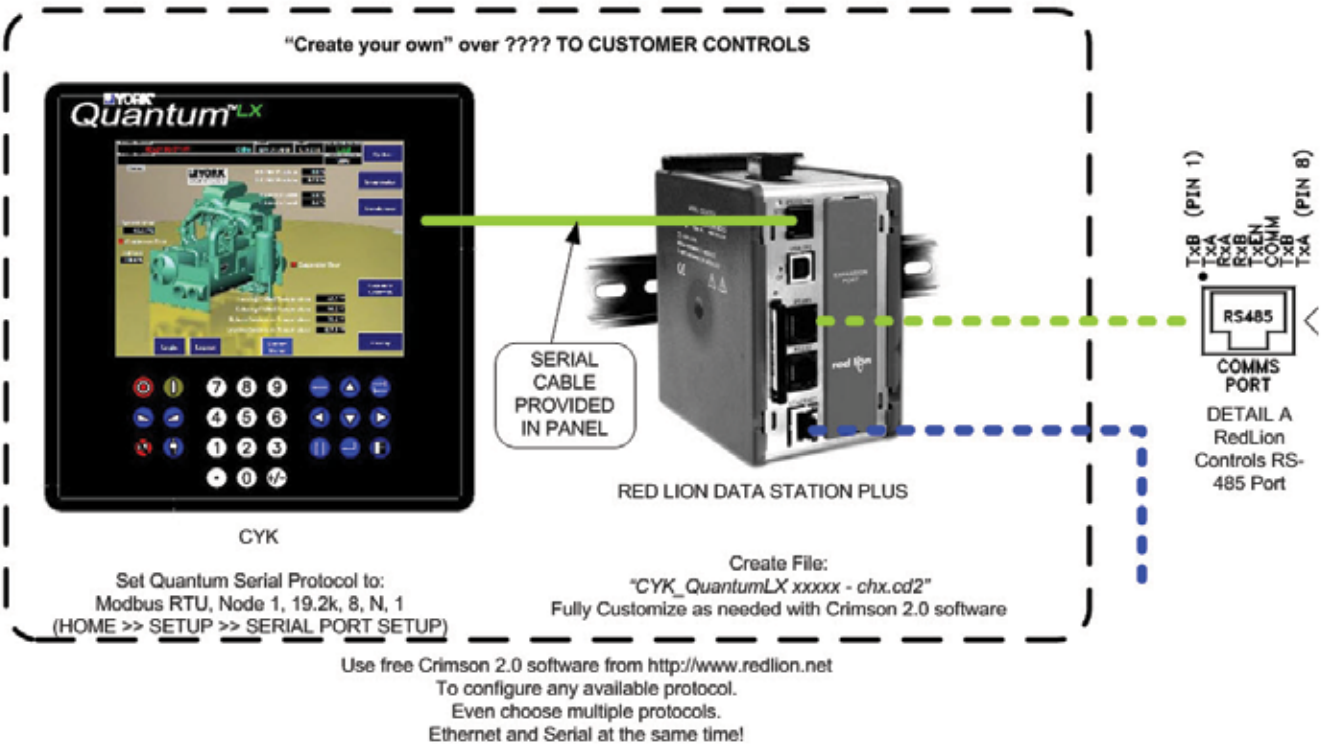

LD16263

FIGURE 97 - CREATE YOUR OWN

HOW TO UPDATE REDLION DATA STATION PLUS CONFIGURATION

Updating the configuration of a Red Lion Controls Data Station Plus is straightforward. The following tools are required:

Crimson 2.0 software available at link above.

A USB A to B cable to plug the laptop into the Data Station.

First make sure your computer has the RedLion USB driver installed. You only have to do this once.

Instructions Here

- Obtain a ".cd2" or ".cd3" crimson configuration file from the factory (or create your own)
- Open the ".cd2" or ".cd3" file by double clicking on it which launches Crimson
- Click the LINK menu and select OPTIONS
- Select USB for the communications port
- Click OK
- Click the LINK menu and select UPDATE

The RLC Data Station Plus will be update with the new configuration file.

Test to see if data is available by doubling clicking on the COMMUNICATIONS icon in Crimson.

- Click on the PLUS sign next to the port you are using (RS-232, RS-485, Ethernet).
- Click on the PLUS sign next to the driver you are using (modbus, bacnet, profibus, etc).
- Right click on any of the data blocks, and select VIEW to see the data.
- Confirm that the data on the chiller matches the points in the data block per the protocol listing provided in this document.

TABLE 14 - QUANTUM LX FOR CYK PROTOCOL LIST
 S/W REVISION 1.13

MODBUS	ALLEN-BRADLEY	BACNET	OFFSET	DESCRIPTION	REMARK
bit	x10	bit		DIGITAL WRITE DATA	
00001	N119:10	BO0001	0	Remote Start Initiate	1= start (clear to 0 after set)
00002	N119:11	BO0002	1	Remote Stop Initiate	1= stop (clear to 0 after set)
00003	N119:12	BO0003	2	Remote System Reset / Alarm Acknowledge	1= ack (clear to 0 after set)
x10	x10	Float		SETPOINT WRITE DATA	
47199	N101:98	AO0001	198	Remote Chilled Water Setpoint	
47202	N102:01	AO0002	201	Remote Condenser Temperature Setpoint	
47168	N101:67	AO0003	167	Demand Limit Setpoint Percentage	
47169	N101:68	AO0004	168	Pulldown Demand Limit Setpoint Percentage	
44567	N45:66	AO0005	566	Communication Units [0= PSIA, °C] [1=panel display units]	Set by BMS
				See panel login page for panel display engineering units	
bit	x10	bit		DIGITAL READ ONLY DATA	Scaling per Protocol
10001	N10:0	BI0001	0	Chilled Water Low Flow Effector Switch	
10002	N10:1	BI0002	1	Condenser Water Low Flow Effector Switch	
10003	N10:2	BI0003	2	LS Motor Starter Full Voltage (Run) Aux Contact	
10004	N10:3	BI0004	3	HS Motor Starter Full Voltage (Run) Aux Contact	
10005	N10:4	BI0005	4	LS Motor Starter Safety Fault Lockout Relay	
10006	N10:5	BI0006	5	HS Motor Starter Safety Fault Lockout Relay	
10007	N10:6	BI0007	6	Condenser Refrig. High Pressure Cutout	
10008	N10:7	BI0008	7	LS Compressor Oil Heater Thermostat	
10009	N10:8	BI0009	8	HS Compressor Oil Heater Thermostat	
10010	N10:9	BI0010	9	LS PRV Closed Limit Switch	
10011	N10:10	BI0011	10	HS PRV Closed Limit Switch	
10012	N10:11	BI0012	11	LS Thrust Switch	Only on certain compressors
10013	N10:12	BI0013	12	HS Thrust Switch	Only on certain compressors
10014	N10:13	BI0014	13	LS Compressor VS Oil Pump Drive Faulted Contact	
10015	N10:14	BI0015	14	HS Compressor VS Oil Pump Drive Faulted Contact	
10016	N10:15	BI0016	15	HS Oil Drain Block Valve Open Limit Switch	Only on ice thermal storage
10017	N10:16	BI0017	16	HS Oil Drain Block Valve Close Limit Switch	Only on ice thermal storage
10018	N10:17	BI0018	17	Chiller Remote Hardwired Start/Stop	
10019	N10:18	BI0019	18	Emergency Stop	
10020	N10:19	BI0020	19	R1 Relay	
10021	N10:20	BI0021	20	Blank	
10022	N10:21	BI0022	21		
10023	N10:22	BI0023	22		
10024	N10:23	BI0024	23		
10025	N10:24	BI0025	24		
10026	N10:25	BI0026	25	LS Liquid Line Solenoid Valve	
10027	N10:26	BI0027	26	HS Liquid Line Solenoid Valve	

5

TABLE 14 - QUANTUM LX FOR CYK PROTOCOL LIST (CONT'D)
S/W REVISION 1.13

MODBUS	ALLEN-BRADLEY	BACNET	OFFSET	DESCRIPTION	REMARK
10028	N10:27	BI0028	27	LS Oil Return Solenoid Valve	
10029	N10:28	BI0029	28	Interstage Sideload Valve	
10030	N10:29	BI0030	29	LS Compressor Oil Heater Contactor	
10031	N10:30	BI0031	30	HS Compressor Oil Heater Contactor	
10032	N10:31	BI0032	31	LS Compressor Motor Start/Stop Control Relay	
10033	N10:32	BI0033	32	HS Compressor Motor Start/Stop Control Relay	
10034	N10:33	BI0034	33	LS Compressor Oil Pump Start/Stop Relay	
10035	N10:34	BI0035	34	HS Compressor Oil Pump Start/Stop Relay	
10036	N10:35	BI0036	35	Oil Transfer Pump Relay	Only on ice thermal storage
10037	N10:36	BI0037	36	HS Oil Transfer Solenoid	Only on ice thermal storage
10038	N10:37	BI0038	37	Condensate Management Relay	Only on ice thermal storage
10039	N10:38	BI0039	38	Economizer Gas Bleed Solenoid	
10040	N10:39	BI0040	39	Open Low Stage PRV	
10041	N10:40	BI0041	40	Open High Stage PRV	
10042	N10:41	BI0042	41	Close Low Stage PRV	
10043	N10:42	BI0043	42	Close High Stage PRV	
10044	N10:43	BI0044	43	Open Low Stage VGD	
10045	N10:44	BI0045	44	Open High Stage VGD	
10046	N10:45	BI0046	45	Close Low Stage VGD	
10047	N10:46	BI0047	46	Close High Stage VGD	
10048	N10:47	BI0048	47	Blank	
10049	N10:48	BI0049	48		
10050	N10:49	BI0050	49		
10051	N10:50	BI0051	50		
10052	N10:51	BI0052	51	Software System Reset R1 Safety Relay	
10053	N10:52	BI0053	52	Chiller Running	
10054	N10:53	BI0054	53	Chiller Common Alarm	
x10	x10	Float		ANALOG READ ONLY DATA	Scaling per Protocol
42001	N20:0	AI0001	0	Low Stage Motor Current (Amps)	
42002	N20:1	AI0002	1	High Stage Motor Current (Amps)	
42003	N20:2	AI0003	2	Evaporator Refrig. Pressure	
42004	N20:3	AI0004	3	Condenser Refrig. Pressure	
42005	N20:4	AI0005	4	Economizer Refrig. Pressure	
42006	N20:5	AI0006	5	Low Stage Compressor Low Oil Pressure	
42007	N20:6	AI0007	6	High Stage Compressor Low Oil Pressure	
42008	N20:7	AI0008	7	Low Stage Compressor High Oil Pressure	
42009	N20:8	AI0009	8	High Stage Compressor High Oil Pressure	
42010	N20:9	AI0010	9	LS Oil Reservoir Level	Only on ice thermal storage
42011	N20:10	AI0011	10	HS Oil Reservoir Level	Only on ice thermal storage
42012	N20:11	AI0012	11	Subcooler Refrig. Liquid Level	
42013	N20:12	AI0013	12	Economizer Refrig. Liquid Level	
42014	N20:13	AI0014	13	LS Comp HS Thrust Bearing Probe Gap	Only on certain compressors

TABLE 14 - QUANTUM LX FOR CYK PROTOCOL LIST (CONT'D)
 S/W REVISION 1.13

MODBUS	ALLEN-BRADLEY	BACNET	OFFSET	DESCRIPTION	REMARK
42015	N20:14	AI0015	14	HS Comp HS Thrust Bearing Probe Gap	Only on certain compressors
42016	N20:15	AI0016	15	Low Stage PRV Position	
42017	N20:16	AI0017	16	High Stage PRV Position	
42018	N20:17	AI0018	17	Hardwired Remote Chilled Water Setpoint	
42019	N20:18	AI0019	18	Chilled Water Out Temperature	
42020	N20:19	AI0020	19	Chilled Water In Temperature	
42021	N20:20	AI0021	20	Condenser Water Out Temperature	
42022	N20:21	AI0022	21	Condenser Water In Temperature	
42023	N20:22	AI0023	22	Evaporator Refrig. Liquid Temperature	
42024	N20:23	AI0024	23	LS Comp Refrig. Discharge Temperature	
42025	N20:24	AI0025	24	HS Comp Refrig. Discharge Temperature	
42026	N20:25	AI0026	25	Subcooled Refrig. Liquid Temperature	
42027	N20:26	AI0027	26	Low Stage Compressor Oil Temperature	
42028	N20:27	AI0028	27	High Stage Compressor Oil Temperature	
42029	N20:28	AI0029	28	Five Volt Supply	
42030	N20:29	AI0030	29	Hardwired Remote Heating Water Setpoint	only on heat pumps
42031	N20:30	AI0031	30	Blank	
42032	N20:31	AI0032	31	User defined analog input #1	
42033	N20:32	AI0033	32	User defined analog input #2	
42034	N20:33	AI0034	33	User defined analog input #3	
42035	N20:34	AI0035	34	User defined analog input #4	
42036	N20:35	AI0036	35	User defined analog input #5	
42037	N20:36	AI0037	36	User defined analog input #6	
42038	N20:37	AI0038	37	User defined analog input #7	
42039	N20:38	AI0039	38	User defined analog input #8	
42040	N20:39	AI0040	39	User defined analog input #9	
42041	N20:40	AI0041	40	User defined analog input #10	
42042	N20:41	AI0042	41	User defined analog input #11	
42043	N20:42	AI0043	42	User defined analog input #12	
42044	N20:43	AI0044	43	User defined analog input #13	
42045	N20:44	AI0045	44	User defined analog input #14	
42046	N20:45	AI0046	45	User defined analog input #15	
42047	N20:46	AI0047	46	User defined analog input #16	
42048	N20:47	AI0048	47	User defined analog input #17	
42049	N20:48	AI0049	48	User defined analog input #18	
42050	N20:49	AI0050	49	User defined analog input #19	
42051	N20:50	AI0051	50	User defined analog input #20	
42052	N20:51	AI0052	51	Blank	
42053	N20:52	AI0053	52		
42054	N20:53	AI0054	53		
42055	N20:54	AI0055	54		
42056	N20:55	AI0056	55		

5

TABLE 14 - QUANTUM LX FOR CYK PROTOCOL LIST (CONT'D)
S/W REVISION 1.13

MODBUS	ALLEN-BRADLEY	BACNET	OFFSET	DESCRIPTION	REMARK
42057	N20:56	AI0057	56	Blank	
42058	N20:57	AI0058	57		
42059	N20:58	AI0059	58		
42060	N20:59	AI0060	59	Analog output #1	
42061	N20:60	AI0061	60	Analog output #2	
42062	N20:61	AI0062	61	Analog output #3	
42063	N20:62	AI0063	62	Analog output #4	
42064	N20:63	AI0064	63	Analog output #5	
42065	N20:64	AI0065	64	Analog output #6	
42066	N20:65	AI0066	65	Analog output #7	
42067	N20:66	AI0067	66	Analog output #8	
42068	N20:67	AI0068	67	LS VGD Pressure Sensor / Intermediate Pressure	
42069	N20:68	AI0069	68	LS VGD Stall Noise Level	Only on certain compressors
42070	N20:69	AI0070	69	LS VGD Position	Only on certain compressors
42071	N20:70	AI0071	70	HS VGD Pressure Sensor	Only on certain compressors
42072	N20:71	AI0072	71	HS VGD Stall Noise Level	Only on certain compressors
42073	N20:72	AI0073	72	HS VGD Position	Only on certain compressors
42074	N20:73	AI0074	73	Chilled Water / Brine Flow (GPM)	Option when flow meter is installed
42075	N20:74	AI0075	74	Condenser Water Flow (GPM)	Option when flow meter is installed
42076	N20:75	AI0076	75	Blank	
42077	N20:76	AI0077	76		
42078	N20:77	AI0078	77		
42079	N20:78	AI0079	78		
42080	N20:79	AI0080	79	Hot Gas Bypass Valve	
42081	N20:80	AI0081	80	Subcooler Variable Orifice Valve	
42082	N20:81	AI0082	81	Economizer Variable Orifice Valve	
42083	N20:82	AI0083	82	Economizer Bypass Variable Orifice Valve	
42084	N20:83	AI0084	83	LS Comp VS Oil Pump Drive Control	
42085	N20:84	AI0085	84	HS Comp VS Oil Pump Drive Control	
42086	N20:85	AI0086	85	Analog output #9	
42087	N20:86	AI0087	86	Analog output #10	
42088	N20:87	AI0088	87	Analog output #11	
42089	N20:88	AI0089	88	Analog output #12	
42090	N20:89	AI0090	89	Analog output #13	
42091	N20:90	AI0091	90	Analog output #14	
42092	N20:91	AI0092	91	Analog output #15	
42093	N20:92	AI0093	92	Analog output #16	

TABLE 14 - QUANTUM LX FOR CYK PROTOCOL LIST (CONT'D)
 S/W REVISION 1.13

MODBUS	ALLEN-BRADLEY	BACNET	OFFSET	DESCRIPTION	REMARK
x10	x10	Float		CALCULATED VALUE READ ONLY DATA	Scaling per Protocol
43001	N30:0	AI0100	0	System Head (Cond Pres - Evap Pres)	
43002	N30:1	AI0101	1	Evaporator Small Diff Temp	
43003	N30:2	AI0102	2	Condenser Small Diff Temp	
43004	N30:3	AI0103	3	HS VS Frequency	
43005	N30:4	AI0104	4	LS VS Frequency	
43006	N30:5	AI0105	5	Auto HS VS Oil Pump Drive	
43007	N30:6	AI0106	6	Manual HS VS Oil Pump Drive	
43008	N30:7	AI0107	7	Auto LS VS Oil Pump Drive	
43009	N30:8	AI0108	8	Manual LS VS Oil Pump Drive	
43010	N30:9	AI0109	9	Auto LS Pre-Rotation Vanes	
43011	N30:10	AI0110	10	Manual LS Pre-Rotation Vanes	
43012	N30:11	AI0111	11	Auto HS Pre-Rotation Vanes	
43013	N30:12	AI0112	12	Manual HS Pre-Rotation Vanes	
43014	N30:13	AI0113	13	Auto Subcooler Level Valve	
43015	N30:14	AI0114	14	Manual Subcooler Level Valve	
43016	N30:15	AI0115	15	Auto Economizer Bypass Valve	
43017	N30:16	AI0116	16	Manual Economizer Bypass Valve	
43018	N30:17	AI0117	17	Event Log Flag	
43019	N30:18	AI0118	18	Current Runtime	
43020	N30:19	AI0119	19	Auto Hot Gas Valve	
43021	N30:20	AI0120	20	Manual Hot Gas Valve	
43022	N30:21	AI0121	21	Condenser Saturated Liquid Temperature	
43023	N30:22	AI0122	22	Analog Board 1 Communications Fail	
43024	N30:23	AI0123	23	Analog Board 2 Communications Fail	
43025	N30:24	AI0124	24	Digital Board 1 Communications Fail	
43026	N30:25	AI0125	25	Digital Board 2 Communications Fail	
43027	N30:26	AI0126	26	Analog Board 3 Communications Fail	
43028	N30:27	AI0127	27	Digital Board 1 Reset	
43029	N30:28	AI0128	28	Digital Board 2 Reset	
43030	N30:29	AI0129	29	Evaporator Saturated Liquid Temperature	
43031	N30:30	AI0130	30	Subcooler Level Process Variable	
43032	N30:31	AI0131	31	Economizer Level Process Variable	
43033	N30:32	AI0132	32	Used In Displaying Alarms	
43034	N30:33	AI0133	33	Interstage Saturated Temperature	
43035	N30:34	AI0134	34	Liquid Seal Diff	
43036	N30:35	AI0135	35	Auto Economizer Outlet Valve	
43037	N30:36	AI0136	36	Manual Economizer Outlet Valve	
43038	N30:37	AI0137	37	Chilled Water Out Temp PID Output	
43039	N30:38	AI0138	38	Heat Pump Control PID Output	
43040	N30:39	AI0139	39	HS Motor Load PID Output	

5

TABLE 14 - QUANTUM LX FOR CYK PROTOCOL LIST (CONT'D)
S/W REVISION 1.13

MODBUS	ALLEN-BRADLEY	BACNET	OFFSET	DESCRIPTION	REMARK
43041	N30:40	AI0140	40	Blank	
43042	N30:41	AI0141	41		
43043	N30:42	AI0142	42		
43044	N30:43	AI0143	43		
43045	N30:44	AI0144	44		
43046	N30:45	AI0145	45		
43047	N30:46	AI0146	46		
43048	N30:47	AI0147	47		
43049	N30:48	AI0148	48		
43050	N30:49	AI0149	49		
43051	N30:50	AI0150	50	Auto LS VGD	
43052	N30:51	AI0151	51	Manual LS VGD	
43053	N30:52	AI0152	52	Auto HS VGD	
43054	N30:53	AI0153	53	Manual HS VGD	
43055	N30:54	AI0154	54	Immediate Two Stage	
43056	N30:55	AI0155	55	Chilled Water Out Temp PID Setpoint	
43057	N30:56	AI0156	56	Vane Anti-Surge Calc	
43058	N30:57	AI0157	57	HS Anti-Surge Calc	
43059	N30:58	AI0158	58	LS Anti-Surge Calc	
43060	N30:59	AI0159	59	Antirecycle Hours Til Next Start	
43061	N30:60	AI0160	60	Antirecycle Minutes Til Next Start	
43062	N30:61	AI0161	61	LS Discharge Superheat Temperature	
43063	N30:62	AI0162	62	HS Discharge Superheat Temperature	
43064	N30:63	AI0163	63	Heat Pump Temperature PID Setpoint	
43065	N30:64	AI0164	64	Shutdown Text Index For Email Notification	
43066	N30:65	AI0165	65	HS Oil Supply Pressure	
43067	N30:66	AI0166	66	LS Oil Supply Pressure	
43068	N30:67	AI0167	67	HS Compressor Head	
43069	N30:68	AI0168	68	LS Compressor Head	
43070	N30:69	AI0169	69	Blank	
43071	N30:70	AI0170	70	List Of Current Safeties (0=ok, if non-zero refer to offset in alarm table)	Most Recent
43072	N30:71	AI0171	71		Refer to alarm Table for offset
43073	N30:72	AI0172	72		
43074	N30:73	AI0173	73		
43075	N30:74	AI0174	74		
43076	N30:75	AI0175	75		
43077	N30:76	AI0176	76		
43078	N30:77	AI0177	77		
43079	N30:78	AI0178	78		
43080	N30:79	AI0179	79		
43081	N30:80	AI0180	80	not used	
43082	N30:81	AI0181	81		
43083	N30:82	AI0182	82	Process Stopped Flag	

TABLE 14 - QUANTUM LX FOR CYK PROTOCOL LIST (CONT'D)
 S/W REVISION 1.13

MODBUS	ALLEN-BRADLEY	BACNET	OFFSET	DESCRIPTION	REMARK
43084	N30:83	AI0183	83	HS Oil Pump Frequency	
43085	N30:84	AI0184	84	LS Oil Pump Frequency	
43086	N30:85	AI0185	85	HS Oil Pressure PID Output	
43087	N30:86	AI0186	86	LS Oil Pressure PID Output	
43088	N30:87	AI0187	87	Evaporator Low Press Override PID Output	
43089	N30:88	AI0188	88	Condenser High Press Override PID Output	
43090	N30:89	AI0189	89	Low Stage Motor Limit PID Output	
43091	N30:90	AI0190	90	Interstage Override PID Output	
43092	N30:91	AI0191	91	PRV Antistall PID Output	
43093	N30:92	AI0192	92	Low Stage PRV Position Converted	
43094	N30:93	AI0193	93	High Stage PRV Position Converted	
43095	N30:94	AI0194	94	Analog Output Test Value	
43096	N30:95	AI0195	95	Averaged Low Stage Motor Load	
43097	N30:96	AI0196	96	Averaged High Stage Motor Load	
43098	N30:97	AI0197	97	HS Thrust Prox Diff	
43099	N30:98	AI0198	98	LS Thrust Prox Diff	
43100	N30:99	AI0199	99	SS2	
43101	N30:100	AI0200	100	LSR1	
43102	N30:101	AI0201	101	Hot Gas Ramp	
43103	N30:102	AI0202	102	HSR4	
43104	N30:103	AI0203	103	Evaporator Tonnage in units of TR	Option when flow meter is installed
43105	N30:104	AI0204	104	Runtime Since Last Start Days	
43106	N30:105	AI0205	105	Runtime Since Last Start Hours	
43107	N30:106	AI0206	106	Runtime Since Last Start Minutes	
43108	N30:107	AI0207	107	HS PRV With Offset	
43109	N30:108	AI0208	108	Safety Index Of Oldest Uncleared Shutdown	
43110	N30:109	AI0209	109	LS VGD Scaled Position	
43111	N30:110	AI0210	110	HS VGD Scaled Position	
43112	N30:111	AI0211	111	LSR3	
43113	N30:112	AI0212	112	LSR2	
43114	N30:113	AI0213	113	LSR4	
43115	N30:114	AI0214	114	SS1	
43116	N30:115	AI0215	115	HSR2	
43117	N30:116	AI0216	116	HSR1	
43118	N30:117	AI0217	117	Blank	
43119	N30:118	AI0218	118		
43120	N30:119	AI0219	119	Range Converter Result	
43121	N30:120	AI0220	120	HSR3	
43122	N30:121	AI0221	121	LS Motor Load Percent	
43123	N30:122	AI0222	122	HS Motor Load Percent	
43124	N30:123	AI0223	123	LS Motor Kilowatts	LCSSS / MVSSS Starter Comms Only

5

TABLE 14 - QUANTUM LX FOR CYK PROTOCOL LIST (CONT'D)
S/W REVISION 1.13

MODBUS	ALLEN-BRADLEY	BACNET	OFFSET	DESCRIPTION	REMARK
43125	N30:124	AI0224	124	Condenser Heat Rejection in units of MBH	Option when flow meter is installed
43126	N30:125	AI0225	125	LS LCSSS Phase A Voltage	LCSSS / MVSSS Starter Comms Only
43127	N30:126	AI0226	126	LS LCSSS Phase B Voltage	
43128	N30:127	AI0227	127	LS LCSSS Phase C Voltage	
43129	N30:128	AI0228	128	LS LCSSS Phase A Current	
43130	N30:129	AI0229	129	LS LCSSS Phase B Current	
43131	N30:130	AI0230	130	LS LCSSS Phase C Current	
43132	N30:131	AI0231	131	LS LCSSS Phase A Temperature	
43133	N30:132	AI0232	132	LS LCSSS Phase B Temperature	
43134	N30:133	AI0233	133	LS LCSSS Phase C Temperature	
43135	N30:134	AI0234	134	HS LCSSS INPUT POWER KW	
43136	N30:135	AI0235	135	Blank	
43137	N30:136	AI0236	136	HS LCSSS Phase A Voltage	LCSSS / MVSSS Starter Comms Only
43138	N30:137	AI0237	137	HS LCSSS Phase B Voltage	
43139	N30:138	AI0238	138	HS LCSSS Phase C Voltage	
43140	N30:139	AI0239	139	HS LCSSS Phase A Current	
43141	N30:140	AI0240	140	HS LCSSS Phase B Current	
43142	N30:141	AI0241	141	HS LCSSS Phase C Current	
43143	N30:142	AI0242	142	HS LCSSS Phase A Temperature	
43144	N30:143	AI0243	143	HS LCSSS Phase B Temperature	
43145	N30:144	AI0244	144	HS LCSSS Phase C Temperature	
x10	x10	Float		MODE VALUE READ ONLY DATA	
44001	N40:0	AI0300	0	Copy of Setpoint 0 (User Level)	0=View, 1=Operator, 2=Service, 3=Factory; 4=Prog.
44002	N40:1	AI0301	1	Control Mode	0=Chiller, 1=Heat Pump
44003	N40:2	AI0302	2	LS Prelube	0=Not in Prelube, 1=In Prelube
44004	N40:3	AI0303	3	LS Postlube	0=Not in Postlube, 1=In Postlube
44005	N40:4	AI0304	4	Shutdown	0=No Shutdowns, 1=Shut-down
44006	N40:5	AI0305	5	Warning	0=No Warning, 1=Warning
44007	N40:6	AI0306	6	Stage Mode	0=Single-Stage, 1=Two-Stage
44008	N40:7	AI0307	7	Chiller Mode	0=Auto, 1=Manual
44009	N40:8	AI0308	8	Blank	
44010	N40:9	AI0309	9	LCV-114 Mode	0=Auto, 1=Manual
44011	N40:10	AI0310	10	LCV-117 Mode	0=Auto, 1=Manual
44012	N40:11	AI0311	11	LS Pre-Rotation Vanes Mode	0=Auto, 1=Manual
44013	N40:12	AI0312	12	HS Pre-Rotation Vanes Mode	0=Auto, 1=Manual
44014	N40:13	AI0313	13	HS VS Oil Pump Drive Mode	0=Auto, 1=Manual
44015	N40:14	AI0314	14	LS VS Oil Pump Drive Mode	0=Auto, 1=Manual
44016	N40:15	AI0315	15	Hot Gas Valve Mode	0=Auto, 1=Manual

TABLE 14 - QUANTUM LX FOR CYK PROTOCOL LIST (CONT'D)
 S/W REVISION 1.13

MODBUS	ALLEN-BRADLEY	BACNET	OFFSET	DESCRIPTION	REMARK
44017	N40:16	AI0316	16	LCV-116 Mode	0=Auto, 1=Manual
44018	N40:17	AI0317	17	Oil Sump Mode	0=Ice, 1=Heatpump
44019	N40:18	AI0318	18	LS VGD Mode	0=Auto, 1=Manual
44020	N40:19	AI0319	19	HS VGD Mode	0=Auto, 1=Manual
44021	N40:20	AI0320	20	System Status	0=Ready To Start, 1=Remote Start Enabled, 2=Start / LS Prelube, 3=Rem Start / LS Prelube, 4=System Running 2-Stage, 5=System Coastdown, 6=System Tripped, 7=Antirecycle, 8=Low Stage Running, 9=Vaness Closing, 10=Remote Lockout, 11=HS Start / Prelube, 12=Running / Dynamic Override
44022	N40:21	AI0321	21	Start Mode	0=Local, 1=Remote
44023	N40:22	AI0322	22	Setpoint Mode (Control Source)	0=Local, 1=Remote
44024	N40:23	AI0323	23	Oil Sump Lubrication	0=Auto, 1=Lock On
44025	N40:24	AI0324	24	Blank	Modbus and AB protocols 0= ok 10 decimal = alarm timing 20 decimal = state of alarm
44026	N40:25	AI0325	25		
44027	N40:26	AI0326	26		
44028	N40:27	AI0327	27	LS VGD Algorithm Mode	0=Wait, 1=Probe, 2=React
44029	N40:28	AI0328	28	HS VGD Algorithm Mode	0=Wait, 1=Probe, 2=React
44030	N40:29	AI0329	29	LS VGD Calibration In Progress	0=No, 1=Yes
44031	N40:30	AI0330	30	HS VGD Calibration In Progress	0=No, 1=Yes
44032	N40:31	AI0331	31	HS Prelube	0=Not in Prelube, 1=In Prelube
44033	N40:32	AI0332	32	HS Postlube	0 = Not in Postlube, 1 = In Postlube
44034	N40:33	AI0333	33	System Is Coasting Down	0 = No, 1 = Yes
44035	N40:34	AI0334	34	Anti-recycle Active	0 = No, 1 = Yes
44036	N40:35	AI0335	35	PRV Calibration In Progress	0 = No, 1 = Yes
X10	X10	FLOAT		ALARM TABLE (OFFSET) ALARM WARNING / SHUTDOWN READ ONLY DATA	0 = ok, 1 decimal = alarm timing, 2 decimal = state of alarm, Scaling Per Protocol
45001	N50:0	AI0500	0	Blank	Modbus and AB protocols, 0 = ok, 10 decimal = alarm timing 20 decimal = state of alarm
45002	N50:1	AI0501	1		
45003	N50:2	AI0502	2		
45004	N50:3	AI0503	3	Warning: Vane Motor Switches Not Closed	
45005	N50:4	AI0504	4	Warning: High Discharge Temperature	
45006	N50:5	AI0505	5	Warning: High Discharge Pressure	
45007	N50:6	AI0506	6	Warning: High Stage Proximity Forward	
45008	N50:7	AI0507	7	Warning: High Stage Proximity Reverse	
45009	N50:8	AI0508	8	Warning: High Stage High Oil Pressure	

5

TABLE 14 - QUANTUM LX FOR CYK PROTOCOL LIST (CONT'D)
S/W REVISION 1.13

MODBUS	ALLEN-BRADLEY	BACNET	OFFSET	DESCRIPTION	REMARK
45010	N50:9	AI0509	9	Warning: High Stage High Oil Temperature	
45011	N50:10	AI0510	10	Warning: High Stage Interlock W/O Run	
45012	N50:11	AI0511	11	Warning: Low Discharge Temp On High Stage	
45013	N50:12	AI0512	12	Warning: High Stage Low Oil Pressure	
45014	N50:13	AI0513	13	Warning: High Stage Low Oil Temperature	
45015	N50:14	AI0514	14	Warning: Low Stage Interlock W/O Run	
45016	N50:15	AI0515	15	Warning: High Hs Oil Reservoir Level	
45017	N50:16	AI0516	16	Warning: Low Hs Oil Reservoir Level	
45018	N50:17	AI0517	17	Warning: High Economizer Refrig. Press	
45019	N50:18	AI0518	18	Warning: High Interstage Pressure	
45020	N50:19	AI0519	19	Warning: Invalid Antisurge Parameters Entered	
45021	N50:20	AI0520	20		
45022	N50:21	AI0521	21	Warning: Low Evaporator Pressure	
45023	N50:22	AI0522	22		
45024	N50:23	AI0523	23	Warning: Low Leaving Chilled Water Temp	
45025	N50:24	AI0524	24	Warning: Low Stage Proximitor Forward	
45026	N50:25	AI0525	25	Warning: Low Stage Proximitor Reverse	
45027	N50:26	AI0526	26	Warning: Low Stage High Oil Pressure	
45028	N50:27	AI0527	27	Warning: Low Stage High Oil Temperature	
45029	N50:28	AI0528	28	Warning: Low Stage Interlock W/O Run	
45030	N50:29	AI0529	29	Warning: Low Stage Low Oil Pressure	
45031	N50:30	AI0530	30	Warning: Low Stage Low Oil Temperature	
45032	N50:31	AI0531	31	Warning: Low Stage Motor Current W/O Run	
45033	N50:32	AI0532	32	Warning: Low Stage High Reservoir Level	
45034	N50:33	AI0533	33	Warning: Low Stage Low Reservoir Level	
45035	N50:34	AI0534	34	Warning: Remote Start Denied / Check Mode	
45036	N50:35	AI0535	35	Warning: Check Battery	
45037	N50:36	AI0536	36	Warning: High Stage Motor Current W/O Run	
45038	N50:37	AI0537	37	Warning: High Economizer Vessel Level	
45039	N50:38	AI0538	38	Warning: Sideload Forced Closed, High Level	
45040	N50:39	AI0539	39	Warning: High Sideload Differential	
45041	N50:40	AI0540	40	Warning: Hs Oil Drain Not Open	
45042	N50:41	AI0541	41	Warning: Hs Oil Drain Not Closed	
45043	N50:42	AI0542	42	Warning: Hs Thrust Probe Cal Active	
45044	N50:43	AI0543	43	Warning: Ls Thrust Probe Cal Active	

TABLE 14 - QUANTUM LX FOR CYK PROTOCOL LIST (CONT'D)
 S/W REVISION 1.13

MODBUS	ALLEN-BRADLEY	BACNET	OFFSET	DESCRIPTION	REMARK
45045	N50:44	AI0544	44	Blank	
45046	N50:45	AI0545	45		
45047	N50:46	AI0546	46		
45048	N50:47	AI0547	47		
45049	N50:48	AI0548	48		
45050	N50:49	AI0549	49		
45051	N50:50	AI0550	50		
45052	N50:51	AI0551	51		
45053	N50:52	AI0552	52		
45054	N50:53	AI0553	53		
45055	N50:54	AI0554	54		
45056	N50:55	AI0555	55		
45057	N50:56	AI0556	56		
45058	N50:57	AI0557	57		
45059	N50:58	AI0558	58		
45060	N50:59	AI0559	59		
45061	N50:60	AI0560	60		
45062	N50:61	AI0561	61		
45063	N50:62	AI0562	62		
45064	N50:63	AI0563	63	Auxiliary Input 1 Shutdown	
45065	N50:64	AI0564	64	Auxiliary Input 1 Warning	
45066	N50:65	AI0565	65	Auxiliary Input 2 Shutdown	
45067	N50:66	AI0566	66	Auxiliary Input 2 Warning	
45068	N50:67	AI0567	67	Auxiliary Input 3 Shutdown	
45069	N50:68	AI0568	68	Auxiliary Input 3 Warning	
45070	N50:69	AI0569	69	Auxiliary Input 4 Shutdown	
45071	N50:70	AI0570	70	Auxiliary Input 4 Warning	
45072	N50:71	AI0571	71	Auxiliary Input 5 Shutdown	
45073	N50:72	AI0572	72	Auxiliary Input 5 Warning	
45074	N50:73	AI0573	73	Auxiliary Input 6 Shutdown	
45075	N50:74	AI0574	74	Auxiliary Input 6 Warning	
45076	N50:75	AI0575	75	Auxiliary Input 7 Shutdown	
45077	N50:76	AI0576	76	Auxiliary Input 7 Warning	
45078	N50:77	AI0577	77	Auxiliary Input 8 Shutdown	
45079	N50:78	AI0578	78	Auxiliary Input 8 Warning	
45080	N50:79	AI0579	79	Auxiliary Input 9 Shutdown	
45081	N50:80	AI0580	80	Auxiliary Input 9 Warning	
45082	N50:81	AI0581	81	Auxiliary Input 10 Shutdown	
45083	N50:82	AI0582	82	Auxiliary Input 10 Warning	
45084	N50:83	AI0583	83	High Auxiliary Analog 1 Shutdown	
45085	N50:84	AI0584	84	High Auxiliary Analog 1 Warning	
45086	N50:85	AI0585	85	Low Auxiliary Analog 1 Shutdown	

5

TABLE 14 - QUANTUM LX FOR CYK PROTOCOL LIST (CONT'D)
S/W REVISION 1.13

MODBUS	ALLEN-BRADLEY	BACNET	OFFSET	DESCRIPTION	REMARK
45087	N50:86	AI0586	86	Low Auxiliary Analog 1 Warning	
45088	N50:87	AI0587	87	High Auxiliary Analog 2 Shutdown	
45089	N50:88	AI0588	88	High Auxiliary Analog 2 Warning	
45090	N50:89	AI0589	89	Low Auxiliary Analog 2 Shutdown	
45091	N50:90	AI0590	90	Low Auxiliary Analog 2 Warning	
45092	N50:91	AI0591	91	High Auxiliary Analog 3 Shutdown	
45093	N50:92	AI0592	92	High Auxiliary Analog 3 Warning	
45094	N50:93	AI0593	93	Low Auxiliary Analog 3 Shutdown	
45095	N50:94	AI0594	94	Low Auxiliary Analog 3 Warning	
45096	N50:95	AI0595	95	High Auxiliary Analog 4 Shutdown	
45097	N50:96	AI0596	96	High Auxiliary Analog 4 Warning	
45098	N50:97	AI0597	97	Low Auxiliary Analog 4 Shutdown	
45099	N50:98	AI0598	98	Low Auxiliary Analog 4 Warning	
45100	N50:99	AI0599	99	High Auxiliary Analog 5 Shutdown	
45101	N50:100	AI0600	100	High Auxiliary Analog 5 Warning	
45102	N50:101	AI0601	101	Low Auxiliary Analog 5 Shutdown	
45103	N50:102	AI0602	102	Low Auxiliary Analog 5 Warning	
45104	N50:103	AI0603	103	High Auxiliary Analog 6 Shutdown	
45105	N50:104	AI0604	104	High Auxiliary Analog 6 Warning	
45106	N50:105	AI0605	105	Low Auxiliary Analog 6 Shutdown	
45107	N50:106	AI0606	106	Low Auxiliary Analog 6 Warning	
45108	N50:107	AI0607	107	High Auxiliary Analog 7 Shutdown	
45109	N50:108	AI0608	108	High Auxiliary Analog 7 Warning	
45110	N50:109	AI0609	109	Low Auxiliary Analog 7 Shutdown	
45111	N50:110	AI0610	110	Low Auxiliary Analog 7 Warning	
45112	N50:111	AI0611	111	High Auxiliary Analog 8 Shutdown	
45113	N50:112	AI0612	112	High Auxiliary Analog 8 Warning	
45114	N50:113	AI0613	113	Low Auxiliary Analog 8 Shutdown	
45115	N50:114	AI0614	114	Low Auxiliary Analog 8 Warning	
45116	N50:115	AI0615	115	High Auxiliary Analog 9 Shutdown	
45117	N50:116	AI0616	116	High Auxiliary Analog 9 Warning	
45118	N50:117	AI0617	117	Low Auxiliary Analog 9 Shutdown	
45119	N50:118	AI0618	118	Low Auxiliary Analog 9 Warning	
45120	N50:119	AI0619	119	High Auxiliary Analog 10 Shutdown	
45121	N50:120	AI0620	120	High Auxiliary Analog 10 Warning	
45122	N50:121	AI0621	121	Low Auxiliary Analog 10 Shutdown	
45123	N50:122	AI0622	122	Low Auxiliary Analog 10 Warning	

TABLE 14 - QUANTUM LX FOR CYK PROTOCOL LIST (CONT'D)
 S/W REVISION 1.13

MODBUS	ALLEN-BRADLEY	BACNET	OFFSET	DESCRIPTION	REMARK
45124	N50:123	AI0623	123	Blank	
45125	N50:124	AI0624	124		
45126	N50:125	AI0625	125		
45127	N50:126	AI0626	126		
45128	N50:127	AI0627	127		
45129	N50:128	AI0628	128		
45130	N50:129	AI0629	129		
45131	N50:130	AI0630	130		
45132	N50:131	AI0631	131	Auxiliary Input 11 Shutdown	
45133	N50:132	AI0632	132	Auxiliary Input 11 Warning	
45134	N50:133	AI0633	133	Auxiliary Input 12 Shutdown	
45135	N50:134	AI0634	134	Auxiliary Input 12 Warning	
45136	N50:135	AI0635	135	Auxiliary Input 13 Shutdown	
45137	N50:136	AI0636	136	Auxiliary Input 13 Warning	
45138	N50:137	AI0637	137	Auxiliary Input 14 Shutdown	
45139	N50:138	AI0638	138	Auxiliary Input 14 Warning	
45140	N50:139	AI0639	139	Auxiliary Input 15 Shutdown	
45141	N50:140	AI0640	140	Auxiliary Input 15 Warning	
45142	N50:141	AI0641	141	Auxiliary Input 16 Shutdown	
45143	N50:142	AI0642	142	Auxiliary Input 16 Warning	
45144	N50:143	AI0643	143	Auxiliary Input 17 Shutdown	
45145	N50:144	AI0644	144	Auxiliary Input 17 Warning	
45146	N50:145	AI0645	145	Auxiliary Input 18 Shutdown	
45147	N50:146	AI0646	146	Auxiliary Input 18 Warning	
45148	N50:147	AI0647	147	Auxiliary Input 19 Shutdown	
45149	N50:148	AI0648	148	Auxiliary Input 19 Warning	
45150	N50:149	AI0649	149	Auxiliary Input 20 Shutdown	
45151	N50:150	AI0650	150	Auxiliary Input 20 Warning	
45152	N50:151	AI0651	151	High Auxiliary Analog 11 Shutdown	
45153	N50:152	AI0652	152	High Auxiliary Analog 11 Warning	
45154	N50:153	AI0653	153	Low Auxiliary Analog 11 Shutdown	
45155	N50:154	AI0654	154	Low Auxiliary Analog 11 Warning	
45156	N50:155	AI0655	155	High Auxiliary Analog 12 Shutdown	
45157	N50:156	AI0656	156	High Auxiliary Analog 12 Warning	
45158	N50:157	AI0657	157	Low Auxiliary Analog 12 Shutdown	
45159	N50:158	AI0658	158	Low Auxiliary Analog 12 Warning	
45160	N50:159	AI0659	159	High Auxiliary Analog 13 Shutdown	
45161	N50:160	AI0660	160	High Auxiliary Analog 13 Warning	
45162	N50:161	AI0661	161	Low Auxiliary Analog 13 Shutdown	
45163	N50:162	AI0662	162	Low Auxiliary Analog 13 Warning	
45164	N50:163	AI0663	163	High Auxiliary Analog 14 Shutdown	
45165	N50:164	AI0664	164	High Auxiliary Analog 14 Warning	

5

TABLE 14 - QUANTUM LX FOR CYK PROTOCOL LIST (CONT'D)
S/W REVISION 1.13

MODBUS	ALLEN-BRADLEY	BACNET	OFFSET	DESCRIPTION	REMARK
45166	N50:165	AI0665	165	Low Auxiliary Analog 14 Shutdown	
45167	N50:166	AI0666	166	Low Auxiliary Analog 14 Warning	
45168	N50:167	AI0667	167	High Auxiliary Analog 15 Shutdown	
45169	N50:168	AI0668	168	High Auxiliary Analog 15 Warning	
45170	N50:169	AI0669	169	Low Auxiliary Analog 15 Shutdown	
45171	N50:170	AI0670	170	Low Auxiliary Analog 15 Warning	
45172	N50:171	AI0671	171	High Auxiliary Analog 16 Shutdown	
45173	N50:172	AI0672	172	High Auxiliary Analog 16 Warning	
45174	N50:173	AI0673	173	Low Auxiliary Analog 16 Shutdown	
45175	N50:174	AI0674	174	Low Auxiliary Analog 16 Warning	
45176	N50:175	AI0675	175	High Auxiliary Analog 17 Shutdown	
45177	N50:176	AI0676	176	High Auxiliary Analog 17 Warning	
45178	N50:177	AI0677	177	Low Auxiliary Analog 17 Shutdown	
45179	N50:178	AI0678	178	Low Auxiliary Analog 17 Warning	
45180	N50:179	AI0679	179	High Auxiliary Analog 18 Shutdown	
45181	N50:180	AI0680	180	High Auxiliary Analog 18 Warning	
45182	N50:181	AI0681	181	Low Auxiliary Analog 18 Shutdown	
45183	N50:182	AI0682	182	Low Auxiliary Analog 18 Warning	
45184	N50:183	AI0683	183	High Auxiliary Analog 19 Shutdown	
45185	N50:184	AI0684	184	High Auxiliary Analog 19 Warning	
45186	N50:185	AI0685	185	Low Auxiliary Analog 19 Shutdown	
45187	N50:186	AI0686	186	Low Auxiliary Analog 19 Warning	
45188	N50:187	AI0687	187	High Auxiliary Analog 20 Shutdown	
45189	N50:188	AI0688	188	High Auxiliary Analog 20 Warning	
45190	N50:189	AI0689	189	Low Auxiliary Analog 20 Shutdown	
45191	N50:190	AI0690	190	Low Auxiliary Analog 20 Warning	
45192	N50:191	AI0691	191	Analog Board 1 Communications Shutdown	
45193	N50:192	AI0692	192	Analog Board 2 Communications Shutdown	
45194	N50:193	AI0693	193	Digital Board 1 Communications Shutdown	
45195	N50:194	AI0694	194	Digital Board 2 Communications Shutdown	
45196	N50:195	AI0695	195	Analog Board 3 Communications Shutdown	
45197	N50:196	AI0696	196	Digital Board 1 Reset	
45198	N50:197	AI0697	197	Digital Board 2 Reset	
45199	N50:198	AI0698	198		
45200	N50:199	AI0699	199	Blank	
45201	N50:200	AI0700	200		
45202	N50:201	AI0701	201	Trip: +5 Volt Supply Has Failed	
45203	N50:202	AI0702	202	Trip: Bypass Didn't Close	
45204	N50:203	AI0703	203	Trip: Bypass Didn't Open	
45205	N50:204	AI0704	204	Trip: Low Chilled Flow Switch	
45206	N50:205	AI0705	205	Trip: Low Condenser Flow Switch	
45207	N50:206	AI0706	206	Blank	

TABLE 14 - QUANTUM LX FOR CYK PROTOCOL LIST (CONT'D)
 S/W REVISION 1.13

MODBUS	ALLEN-BRADLEY	BACNET	OFFSET	DESCRIPTION	REMARK
45208	N50:207	AI0707	207	Trip: Emergency Stop Pulled	
45209	N50:208	AI0708	208	Blank	
45210	N50:209	AI0709	209	Trip: High Discharge Temperature	
45211	N50:210	AI0710	210	Trip: High Discharge Pressure	
45212	N50:211	AI0711	211	Trip: High Pressure Cutout	
45213	N50:212	AI0712	212	Trip: High Stage Proximitor Forward	
45214	N50:213	AI0713	213	Trip: High Stage Proximitor Reverse	
45215	N50:214	AI0714	214	Trip: High Stage High Oil Pressure	
45216	N50:215	AI0715	215	Trip: High Stage High Oil Temperature	
45217	N50:216	AI0716	216	Trip: High Stage Low Oil Pressure	
45218	N50:217	AI0717	217	Trip: High Stage Low Oil Temperature	
45219	N50:218	AI0718	218	Trip: High Stage Motor Must Be Uncoupled	
45220	N50:219	AI0719	219	Trip: High Stage Motor Interlock Lost	
45221	N50:220	AI0720	220	Trip: High Stage Oil Pump Didn't Start	
45222	N50:221	AI0721	221	Trip: High Stage Prox Is Uncalibrated	
45223	N50:222	AI0722	222	Trip: High Economizer Refrig. Press	
45224	N50:223	AI0723	223	Trip: High Interstage Pressure	
45225	N50:224	AI0724	224	Trip: Hs Compressor Thrust Bearing Switch Fail	
45226	N50:225	AI0725	225	Blank	
45227	N50:226	AI0726	226	Trip: Ls Compressor Thrust Bearing Switch Fail	
45228	N50:227	AI0727	227	Trip: Low Evaporator Pressure	
45229	N50:228	AI0728	228	Blank	
45230	N50:229	AI0729	229	Trip: Low Leaving Water Temperature	
45231	N50:230	AI0730	230	Trip: Low Stage Proximity Forward	
45232	N50:231	AI0731	231	Trip: Low Stage Proximity Reverse	
45233	N50:232	AI0732	232	Trip: Low Stage High Oil Pressure	
45234	N50:233	AI0733	233	Trip: Low Stage High Oil Temperature	
45235	N50:234	AI0734	234	Trip: Low Stage Low Oil Pressure	
45236	N50:235	AI0735	235	Trip: Low Stage Low Oil Temperature	
45237	N50:236	AI0736	236	Trip: Low Stage Motor Must Be Uncoupled	
45238	N50:237	AI0737	237	Trip: Low Stage Motor Interlock Lost	
45239	N50:238	AI0738	238	Trip: Low Stage Oil Pump Didn't Start	
45240	N50:239	AI0739	239	Trip: Low Stage Prox Is Uncalibrated	
45241	N50:240	AI0740	240	Trip: Power Failure Detected	
45242	N50:241	AI0741	241	Trip: Major Fault	
45243	N50:242	AI0742	242	Trip: High Stage Main Motor Starter Fault	
45244	N50:243	AI0743	243	Trip: Low Stage Main Motor Starter Fault	
45245	N50:244	AI0744	244	Trip: Excess Motor Starts In 24 Hour Period	
45246	N50:245	AI0745	245	Trip: R1 Safety Relay Not Set	
45247	N50:246	AI0746	246	Trip: Rack 0 Communication Failure	
45248	N50:247	AI0747	247	Trip: Rack 1 Communication Failure	
45249	N50:248	AI0748	248	Trip: A Thrust Proximitor Is Tripped (Call Factory Service)	

5

TABLE 14 - QUANTUM LX FOR CYK PROTOCOL LIST (CONT'D)
S/W REVISION 1.13

MODBUS	ALLEN-BRADLEY	BACNET	OFFSET	DESCRIPTION	REMARK
45250	N50:249	AI0749	249	Trip: Low Stage Oil Pump Did Not Make Setpoint	
45251	N51:0	AI0750	250	Trip: High Stage Oil Pump Did Not Make Setpoint	
45252	N51:1	AI0751	251	Blank	
45253	N51:2	AI0752	252		
45254	N51:3	AI0753	253		
45255	N51:4	AI0754	254		
45256	N51:5	AI0755	255		
45257	N51:6	AI0756	256		
45258	N51:7	AI0757	257		
45259	N51:8	AI0758	258		
45260	N51:9	AI0759	259		
45261	N51:10	AI0760	260		
45262	N51:11	AI0761	261		
45263	N51:12	AI0762	262		
45264	N51:13	AI0763	263		
45265	N51:14	AI0764	264		
45266	N51:15	AI0765	265		
45267	N51:16	AI0766	266		
45268	N51:17	AI0767	267		
45269	N51:18	AI0768	268		
45270	N51:19	AI0769	269		
45271	N51:20	AI0770	270		
45272	N51:21	AI0771	271		
45273	N51:22	AI0772	272		
45274	N51:23	AI0773	273		
45275	N51:24	AI0774	274		
45276	N51:25	AI0775	275		
45277	N51:26	AI0776	276		
45278	N51:27	AI0777	277		
45279	N51:28	AI0778	278		
45280	N51:29	AI0779	279		
45281	N51:30	AI0780	280		
45282	N51:31	AI0781	281		
45283	N51:32	AI0782	282		
45284	N51:33	AI0783	283		
45285	N51:34	AI0784	284		
45286	N51:35	AI0785	285		
45287	N51:36	AI0786	286		
45288	N51:37	AI0787	287		
45289	N51:38	AI0788	288		
45290	N51:39	AI0789	289		
45291	N51:40	AI0790	290		

TABLE 14 - QUANTUM LX FOR CYK PROTOCOL LIST (CONT'D)
 S/W REVISION 1.13

MODBUS	ALLEN-BRADLEY	BACNET	OFFSET	DESCRIPTION	REMARK
45292	N51:41	AI0791	291		
45293	N51:42	AI0792	292		
45294	N51:43	AI0793	293		
45295	N51:44	AI0794	294		
45296	N51:45	AI0795	295		
45297	N51:46	AI0796	296		
45298	N51:47	AI0797	297		
45299	N51:48	AI0798	298		
45300	N51:49	AI0799	299		
45301	N51:50	AI0800	300		
45302	N51:51	AI0801	301		
45303	N51:52	AI0802	302		
45304	N51:53	AI0803	303		
45305	N51:54	AI0804	304		
45306	N51:55	AI0805	305		
45307	N51:56	AI0806	306		
45308	N51:57	AI0807	307		
45309	N51:58	AI0808	308		
45310	N51:59	AI0809	309		
45311	N51:60	AI0810	310		
45312	N51:61	AI0811	311		
45313	N51:62	AI0812	312	Blank	
45314	N51:63	AI0813	313		
45315	N51:64	AI0814	314		
45316	N51:65	AI0815	315		
45317	N51:66	AI0816	316		
45318	N51:67	AI0817	317		
45319	N51:68	AI0818	318		
45320	N51:69	AI0819	319		
45321	N51:70	AI0820	320		
45322	N51:71	AI0821	321		
45323	N51:72	AI0822	322		
45324	N51:73	AI0823	323		
45325	N51:74	AI0824	324		
45326	N51:75	AI0825	325		
45327	N51:76	AI0826	326		
45328	N51:77	AI0827	327		
45329	N51:78	AI0828	328		
45330	N51:79	AI0829	329		
45331	N51:80	AI0830	330		
45332	N51:81	AI0831	331		
45333	N51:82	AI0832	332		
45334	N51:83	AI0833	333		

5

TABLE 14 - QUANTUM LX FOR CYK PROTOCOL LIST (CONT'D)
S/W REVISION 1.13

MODBUS	ALLEN-BRADLEY	BACNET	OFFSET	DESCRIPTION	REMARK
45335	N51:84	AI0834	334		
45336	N51:85	AI0835	335	Process Stopped - Check Event Log for Details	
45337	N51:86	AI0836	336	LS SSS: Spare 1	
45338	N51:87	AI0837	337	LS SSS: Invalid Starter Model	
45339	N51:88	AI0838	338	LS SSS: Phase Loss	
45340	N51:89	AI0839	339	LS SSS: Phase Locked Loop Alarm	
45341	N51:90	AI0840	340	LS SSS: Power Fault	
45342	N51:91	AI0841	341	LS SSS: Run Signal Alarm	
45343	N51:92	AI0842	342	LS SSS: Current Imbalance	
45344	N51:93	AI0843	343	LS SSS: Current Overload	
45345	N51:94	AI0844	344	LS SSS: High Instantaneous Current	
45346	N51:95	AI0845	345	LS SSS: High Line Voltage	
45347	N51:96	AI0846	346	LS SSS: Low Line Voltage	
45348	N51:97	AI0847	347	LS SSS: Open Scr	
45349	N51:98	AI0848	348	LS SSS: Phase A Shorted Scr	
45350	N51:99	AI0849	349	LS SSS: Phase B Shorted Scr	
45351	N51:100	AI0850	350	LS SSS: Phase C Shorted Scr	
45352	N51:101	AI0851	351	LS SSS: Phase A Inhibit High Temp	
45353	N51:102	AI0852	352	LS SSS: Phase B Inhibit High Temp	
45354	N51:103	AI0853	353	LS SSS: Phase C Inhibit High Temp	
45355	N51:104	AI0854	354	LS SSS: Phase A High Temp	
45356	N51:105	AI0855	355	LS SSS: Phase B High Temp	
45357	N51:106	AI0856	356	LS SSS: Phase C High Temp	
45358	N51:107	AI0857	357	LS SSS: Phase A Open Thermocouple	
45359	N51:108	AI0858	358	LS SSS: Phase B Open Thermocouple	
45360	N51:109	AI0859	359	LS SSS: Phase C Open Thermocouple	
45361	N51:110	AI0860	360	LS SSS: Serial Receive Err	
45362	N51:111	AI0861	361	LS SSS: Spare 26	
45363	N51:112	AI0862	362	LS SSS: Spare 27	
45364	N51:113	AI0863	363	LS SSS: Power Supply Fault	
45365	N51:114	AI0864	364	LS SSS: Phase Rotation Fault	
45366	N51:115	AI0865	365	LS SSS: Spare 30	
45367	N51:116	AI0866	366	LS SSS: Spare 31	
45368	N51:117	AI0867	367	LS SSS: Spare 32	
45369	N51:118	AI0868	368	HS SSS: Spare 1	
45370	N51:119	AI0869	369	HS SSS: Invalid Starter Model	
45371	N51:120	AI0870	370	HS SSS: Phase Loss	
45372	N51:121	AI0871	371	HS SSS: Phase Locked Loop Alarm	
45373	N51:122	AI0872	372	HS SSS: Power Fault	
45374	N51:123	AI0873	373	HS SSS: Run Signal Alarm	
45375	N51:124	AI0874	374	HS SSS: Current Imbalance	
45376	N51:125	AI0875	375	HS SSS: Current Overload	

TABLE 14 - QUANTUM LX FOR CYK PROTOCOL LIST (CONT'D)
 S/W REVISION 1.13

MODBUS	ALLEN-BRADLEY	BACNET	OFFSET	DESCRIPTION	REMARK
45377	N51:126	AI0876	376	HS SSS: High Instantaneous Current	
45378	N51:127	AI0877	377	HS SSS: High Line Voltage	
45379	N51:128	AI0878	378	HS SSS: Low Line Voltage	
45380	N51:129	AI0879	379	HS SSS: Open SCR	
45381	N51:130	AI0880	380	HS SSS: Phase A Shorted SCR	
45382	N51:131	AI0881	381	HS SSS: Phase B Shorted SCR	
45383	N51:132	AI0882	382	HS SSS: Phase C Shorted SCR	
45384	N51:133	AI0883	383	HS SSS: Phase A Inhibit High Temp	
45385	N51:134	AI0884	384	HS SSS: Phase B Inhibit High Temp	
45386	N51:135	AI0885	385	HS SSS: Phase C Inhibit High Temp	
45387	N51:136	AI0886	386	HS SSS: Phase A High Temp	
45388	N51:137	AI0887	387	HS SSS: Phase B High Temp	
45389	N51:138	AI0888	388	HS SSS: Phase C High Temp	
45390	N51:139	AI0889	389	HS SSS: Phase A Open Thermocouple	
45391	N51:140	AI0890	390	HS SSS: Phase B Open Thermocouple	
45392	N51:141	AI0891	391	HS SSS: Phase C Open Thermocouple	
45393	N51:142	AI0892	392	HS SSS: Serial Receive ERR	
45394	N51:143	AI0893	393	HS SSS: Spare 26	
45395	N51:144	AI0894	394	HS SSS: Spare 27	
45396	N51:145	AI0895	395	HS SSS: Power Supply Fault	
45397	N51:146	AI0896	396	HS SSS: Phase Rotation Fault	
45398	N51:147	AI0897	397	HS SSS: Spare 30	
45399	N51:148	AI0898	398	HS SSS: Spare 31	
45400	N51:149	AI0899	399	HS SSS: Spare 32	
45401	N51:150	AI0900	400	Blank	
45402	N51:151	AI0901	401		
45403	N51:152	AI0902	402		
45404	N51:153	AI0903	403		
45405	N51:154	AI0904	404	Blank	
45406	N51:155	AI0905	405		
45407	N51:156	AI0906	406		
45408	N51:157	AI0907	407		
45409	N51:158	AI0908	408		
45410	N51:159	AI0909	409		
45411	N51:160	AI0910	410		
45412	N51:161	AI0911	411	Low Auxiliary Analog Input #1 Sensor Warning	
45413	N51:162	AI0912	412		
45414	N51:163	AI0913	413		
45415	N51:164	AI0914	414		
45416	N51:165	AI0915	415		
45417	N51:166	AI0916	416		
45418	N51:167	AI0917	417	High Auxiliary Analog Input #3 Sensor Warning	

5

TABLE 14 - QUANTUM LX FOR CYK PROTOCOL LIST (CONT'D)
S/W REVISION 1.13

MODBUS	ALLEN-BRADLEY	BACNET	OFFSET	DESCRIPTION	REMARK
45419	N51:168	AI0918	418	Low Auxiliary Analog Input #4 Sensor Warning	
45420	N51:169	AI0919	419	High Auxiliary Analog Input #4 Sensor Warning	
45421	N51:170	AI0920	420	Low Auxiliary Analog Input #5 Sensor Warning	
45422	N51:171	AI0921	421	High Auxiliary Analog Input #5 Sensor Warning	
45423	N51:172	AI0922	422	Low Auxiliary Analog Input #6 Sensor Warning	
45424	N51:173	AI0923	423	High Auxiliary Analog Input #6 Sensor Warning	
45425	N51:174	AI0924	424	Low Auxiliary Analog Input #7 Sensor Warning	
45426	N51:175	AI0925	425	High Auxiliary Analog Input #7 Sensor Warning	
45427	N51:176	AI0926	426	Low Auxiliary Analog Input #8 Sensor Warning	
45428	N51:177	AI0927	427	High Auxiliary Analog Input #8 Sensor Warning	
45429	N51:178	AI0928	428	Low Auxiliary Analog Input #9 Sensor Warning	
45430	N51:179	AI0929	429	High Auxiliary Analog Input #9 Sensor Warning	
45431	N51:180	AI0930	430	Low Auxiliary Analog Input #10 Sensor Warning	
45432	N51:181	AI0931	431	High Auxiliary Analog Input #10 Sensor Warning	
45433	N51:182	AI0932	432	Low Auxiliary Analog Input #11 Sensor Warning	
45434	N51:183	AI0933	433	High Auxiliary Analog Input #11 Sensor Warning	
45435	N51:184	AI0934	434	Low Auxiliary Analog Input #12 Sensor Warning	
45436	N51:185	AI0935	435	High Auxiliary Analog Input #12 Sensor Warning	
45437	N51:186	AI0936	436	Low Auxiliary Analog Input #13 Sensor Warning	
45438	N51:187	AI0937	437	High Auxiliary Analog Input #13 Sensor Warning	
45439	N51:188	AI0938	438	Low Auxiliary Analog Input #14 Sensor Warning	
45440	N51:189	AI0939	439	High Auxiliary Analog Input #14 Sensor Warning	
45441	N51:190	AI0940	440	Low Auxiliary Analog Input #15 Sensor Warning	
45442	N51:191	AI0941	441	High Auxiliary Analog Input #15 Sensor Warning	
45443	N51:192	AI0942	442	Low Auxiliary Analog Input #16 Sensor Warning	
45444	N51:193	AI0943	443	High Auxiliary Analog Input #16 Sensor Warning	
45445	N51:194	AI0944	444	Low Auxiliary Analog Input #17 Sensor Warning	
45446	N51:195	AI0945	445	High Auxiliary Analog Input #17 Sensor Warning	
45447	N51:196	AI0946	446	Low Auxiliary Analog Input #18 Sensor Warning	
45448	N51:197	AI0947	447	High Auxiliary Analog Input #18 Sensor Warning	
45449	N51:198	AI0948	448	Low Auxiliary Analog Input #19 Sensor Warning	
45450	N51:199	AI0949	449	High Auxiliary Analog Input #19 Sensor Warning	
45451	N51:200	AI0950	450	Low Auxiliary Analog Input #20 Sensor Warning	
45452	N51:201	AI0951	451	High Auxiliary Analog Input #20 Sensor Warning	
X10	X10	FLOAT		SYSTEM PARAMETERS	
47173	N101:72	AI1000	172	Single To 2-Stage Setpoint (differential pressure)	Compare to system head
47174	N101:73	AI1001	173	2-Stage To Single Setpoint (differential pressure)	Compare to system head
47175	N101:74	AI1002	174	Immediate 2-Stage Threshold (differential temperature)	Compare to (ECdWT-EChWT)

TABLE 15 - LIST ALARM CODES

CODE	CYK QUANTUMLX PRESENT ALARM CODES AS DEFINED BY REGISTERS 43071 - 43080
0	System Ok
10	Blank
20	
30	Warning: Vane Motor Switches Not Closed
40	Warning: High Discharge Temperature
50	Warning: High Discharge Pressure
60	Warning: High Stage Proximity Forward
70	Warning: High Stage Proximity Reverse
80	Warning: High Stage High Oil Pressure
90	Warning: High Stage High Oil Temperature
100	Warning: High Stage Interlock W/O Run
110	Warning: Low Discharge Temp On High Stage
120	Warning: High Stage Low Oil Pressure
130	Warning: High Stage Low Oil Temperature
140	Warning: Low Stage Interlock W/O Run
150	Warning: High Hs Oil Reservoir Level
160	Warning: Low Hs Oil Reservoir Level
170	Warning: High Economizer Refrig. Press
180	Warning: High Interstage Pressure
190	Warning: Invalid Antisurge Parameters Entered
200	Blank
210	Warning: Low Evaporator Pressure
220	Blank
230	Warning: Low Leaving Chilled Water Temp
240	Warning: Low Stage Proximitor Forward
250	Warning: Low Stage Proximitor Reverse
260	Warning: Low Stage High Oil Pressure
270	Warning: Low Stage High Oil Temperature
280	Warning: Low Stage Interlock W/O Run
290	Warning: Low Stage Low Oil Pressure
300	Warning: Low Stage Low Oil Temperature
310	Warning: Low Stage Motor Current W/O Run
320	Warning: Low Stage High Reservoir Level
330	Warning: Low Stage Low Reservoir Level
340	Warning: Remote Start Denied / Check Mode
350	Warning: Check Battery
360	Warning: High Stage Motor Current W/O Run
370	Warning: High Economizer Vessel Level
380	Warning: Sideload Forced Closed, High Level
390	Warning: High Sideload Differential
400	Warning: Hs Oil Drain Not Open
410	Warning: Hs Oil Drain Not Closed
420	Warning: Hs Thrust Probe Cal Active
430	Warning: Ls Thrust Probe Cal Active

CODE	CYK QUANTUMLX PRESENT ALARM CODES AS DEFINED BY REGISTERS 43071 - 43080
440	Blank
450	
460	
470	
480	
490	
500	
510	
520	
530	
540	
550	
560	
570	
580	
590	
600	
610	
620	
630	Auxiliary Input 1 Shutdown
640	Auxiliary Input 1 Warning
650	Auxiliary Input 2 Shutdown
660	Auxiliary Input 2 Warning
670	Auxiliary Input 3 Shutdown
680	Auxiliary Input 3 Warning
690	Auxiliary Input 4 Shutdown
700	Auxiliary Input 4 Warning
710	Auxiliary Input 5 Shutdown
720	Auxiliary Input 5 Warning
730	Auxiliary Input 6 Shutdown
740	Auxiliary Input 6 Warning
750	Auxiliary Input 7 Shutdown
760	Auxiliary Input 7 Warning
770	Auxiliary Input 8 Shutdown
780	Auxiliary Input 8 Warning
790	Auxiliary Input 9 Shutdown
800	Auxiliary Input 9 Warning
810	Auxiliary Input 10 Shutdown
820	Auxiliary Input 10 Warning
830	High Auxiliary Analog 1 Shutdown
840	High Auxiliary Analog 1 Warning
850	Low Auxiliary Analog 1 Shutdown
860	Low Auxiliary Analog 1 Warning
870	High Auxiliary Analog 2 Shutdown

TABLE 15 - LIST ALARM CODES (CONT'D)

CODE	CYK QUANTUMLX PRESENT ALARM CODES AS DEFINED BY REGISTERS 43071 - 43080
880	High Auxiliary Analog 2 Warning
890	Low Auxiliary Analog 2 Shutdown
900	Low Auxiliary Analog 2 Warning
910	High Auxiliary Analog 3 Shutdown
920	High Auxiliary Analog 3 Warning
930	Low Auxiliary Analog 3 Shutdown
940	Low Auxiliary Analog 3 Warning
950	High Auxiliary Analog 4 Shutdown
960	High Auxiliary Analog 4 Warning
970	Low Auxiliary Analog 4 Shutdown
980	Low Auxiliary Analog 4 Warning
990	High Auxiliary Analog 5 Shutdown
1000	High Auxiliary Analog 5 Warning
1010	Low Auxiliary Analog 5 Shutdown
1020	Low Auxiliary Analog 5 Warning
1030	High Auxiliary Analog 6 Shutdown
1040	High Auxiliary Analog 6 Warning
1050	Low Auxiliary Analog 6 Shutdown
1060	Low Auxiliary Analog 6 Warning
1070	High Auxiliary Analog 7 Shutdown
1080	High Auxiliary Analog 7 Warning
1090	Low Auxiliary Analog 7 Shutdown
1100	Low Auxiliary Analog 7 Warning
1110	High Auxiliary Analog 8 Shutdown
1120	High Auxiliary Analog 8 Warning
1130	Low Auxiliary Analog 8 Shutdown
1140	Low Auxiliary Analog 8 Warning
1150	High Auxiliary Analog 9 Shutdown
1160	High Auxiliary Analog 9 Warning
1170	Low Auxiliary Analog 9 Shutdown
1180	Low Auxiliary Analog 9 Warning
1190	High Auxiliary Analog 10 Shutdown
1200	High Auxiliary Analog 10 Warning
1210	Low Auxiliary Analog 10 Shutdown
1220	Low Auxiliary Analog 10 Warning
1230	Blank
1240	
1250	
1260	
1270	
1280	
1290	
1300	

CODE	CYK QUANTUMLX PRESENT ALARM CODES AS DEFINED BY REGISTERS 43071 - 43080
1310	Auxiliary Input 11 Shutdown
1320	Auxiliary Input 11 Warning
1330	Auxiliary Input 12 Shutdown
1340	Auxiliary Input 12 Warning
1350	Auxiliary Input 13 Shutdown
1360	Auxiliary Input 13 Warning
1370	Auxiliary Input 14 Shutdown
1380	Auxiliary Input 14 Warning
1390	Auxiliary Input 15 Shutdown
1400	Auxiliary Input 15 Warning
1410	Auxiliary Input 16 Shutdown
1420	Auxiliary Input 16 Warning
1430	Auxiliary Input 17 Shutdown
1440	Auxiliary Input 17 Warning
1450	Auxiliary Input 18 Shutdown
1460	Auxiliary Input 18 Warning
1470	Auxiliary Input 19 Shutdown
1480	Auxiliary Input 19 Warning
1490	Auxiliary Input 20 Shutdown
1500	Auxiliary Input 20 Warning
1510	High Auxiliary Analog 11 Shutdown
1520	High Auxiliary Analog 11 Warning
1530	Low Auxiliary Analog 11 Shutdown
1540	Low Auxiliary Analog 11 Warning
1550	High Auxiliary Analog 12 Shutdown
1560	High Auxiliary Analog 12 Warning
1570	Low Auxiliary Analog 12 Shutdown
1580	Low Auxiliary Analog 12 Warning
1590	High Auxiliary Analog 13 Shutdown
1600	High Auxiliary Analog 13 Warning
1610	Low Auxiliary Analog 13 Shutdown
1620	Low Auxiliary Analog 13 Warning
1630	High Auxiliary Analog 14 Shutdown
1640	High Auxiliary Analog 14 Warning
1650	Low Auxiliary Analog 14 Shutdown
1660	Low Auxiliary Analog 14 Warning
1670	High Auxiliary Analog 15 Shutdown
1680	High Auxiliary Analog 15 Warning
1690	Low Auxiliary Analog 15 Shutdown
1700	Low Auxiliary Analog 15 Warning
1710	High Auxiliary Analog 16 Shutdown
1720	High Auxiliary Analog 16 Warning
1730	Low Auxiliary Analog 16 Shutdown

TABLE 15 - LIST ALARM CODES (CONT'D)

CODE	CYK QUANTUMLX PRESENT ALARM CODES AS DEFINED BY REGISTERS 43071 - 43080
1740	Low Auxiliary Analog 16 Warning
1750	High Auxiliary Analog 17 Shutdown
1760	High Auxiliary Analog 17 Warning
1770	Low Auxiliary Analog 17 Shutdown
1780	Low Auxiliary Analog 17 Warning
1790	High Auxiliary Analog 18 Shutdown
1800	High Auxiliary Analog 18 Warning
1810	Low Auxiliary Analog 18 Shutdown
1820	Low Auxiliary Analog 18 Warning
1830	High Auxiliary Analog 19 Shutdown
1840	High Auxiliary Analog 19 Warning
1850	Low Auxiliary Analog 19 Shutdown
1860	Low Auxiliary Analog 19 Warning
1870	High Auxiliary Analog 20 Shutdown
1880	High Auxiliary Analog 20 Warning
1890	Low Auxiliary Analog 20 Shutdown
1900	Low Auxiliary Analog 20 Warning
1910	Analog Board 1 Communications Shutdown
1920	Analog Board 2 Communications Shutdown
1930	Digital Board 1 Communications Shutdown
1940	Digital Board 2 Communications Shutdown
1950	Analog Board 3 Communications Shutdown
1960	Digital Board 1 Reset
1970	Digital Board 2 Reset
1980	
1990	Blank
2000	
2010	Trip: +5 Volt Supply Has Failed
2020	Trip: Bypass Didn't Close
2030	Trip: Bypass Didn't Open
2040	Trip: Low Chilled Flow Switch
2050	Trip: Low Condenser Flow Switch
2060	Blank
2070	Trip: Emergency Stop Pulled
2080	Blank
2090	Trip: High Discharge Temperature
2100	Trip: High Discharge Pressure
2110	Trip: High Pressure Cutout
2120	Trip: High Stage Proximitor Forward
2130	Trip: High Stage Proximitor Reverse
2140	Trip: High Stage High Oil Pressure
2150	Trip: High Stage High Oil Temperature
2160	Trip: High Stage Low Oil Pressure

CODE	CYK QUANTUMLX PRESENT ALARM CODES AS DEFINED BY REGISTERS 43071 - 43080
2170	Trip: High Stage Low Oil Temperature
2180	Trip: High Stage Motor Must Be Uncoupled
2190	Trip: High Stage Motor Interlock Lost
2200	Trip: High Stage Oil Pump Didn't Start
2210	Trip: High Stage Prox Is Uncalibrated
2220	Trip: High Economizer Refrig. Press
2230	Trip: High Interstage Pressure
2240	Trip: Hs Compressor Thrust Bearing Switch Fail
2250	Blank
2260	Trip: Ls Compressor Thrust Bearing Switch Fail
2270	Trip: Low Evaporator Pressure
2280	Blank
2290	Trip: Low Leaving Water Temperature
2300	Trip: Low Stage Proximity Forward
2310	Trip: Low Stage Proximity Reverse
2320	Trip: Low Stage High Oil Pressure
2330	Trip: Low Stage High Oil Temperature
2340	Trip: Low Stage Low Oil Pressure
2350	Trip: Low Stage Low Oil Temperature
2360	Trip: Low Stage Motor Must Be Uncoupled
2370	Trip: Low Stage Motor Interlock Lost
2380	Trip: Low Stage Oil Pump Didn't Start
2390	Trip: Low Stage Prox Is Uncalibrated
2400	Trip: Power Failure Detected
2410	Trip: Major Fault
2420	Trip: High Stage Main Motor Starter Fault
2430	Trip: Low Stage Main Motor Starter Fault
2440	Trip: Excess Motor Starts In 24 Hour Period
2450	Trip: R1 Safety Relay Not Set
2460	Trip: Rack 0 Communication Failure
2470	Trip: Rack 1 Communication Failure
2480	Trip: A Thrust Proximitor Is Tripped (Call Factory Service)
2490	Trip: Low Stage Oil Pump Did Not Make Setpoint
2500	Trip: High Stage Oil Pump Did Not Make Setpoint
2510	Trip: Low Stage High Motor Current
2520	Trip: High Stage High Motor Current
2530	Trip: SSS Communications Failure
2540	Trip: LS Oil Pressure Sensors Will Not Zero
2550	Trip: HS Oil Pressure Sensors Will Not Zero
2560	Trip: Excessive Surge

5

TABLE 15 - LIST ALARM CODES (CONT'D)

CODE	CYK QUANTUMLX PRESENT ALARM CODES AS DEFINED BY REGISTERS 43071 - 43080
2570	
2580	
2590	
2600	
2610	
2620	
2630	
2640	
2650	
2660	
2670	
2680	
2690	
2700	
2710	
2720	
2730	
2740	
2750	
2760	
2770	Blank
2780	
2790	
2800	
2810	
2820	
2830	
2840	
2850	
2860	
2870	
2880	
2890	
2900	
2910	
2920	
2930	
2940	
2950	
2960	
2970	
2980	

CODE	CYK QUANTUMLX PRESENT ALARM CODES AS DEFINED BY REGISTERS 43071 - 43080
2990	
3000	
3010	
3020	
3030	
3040	
3050	
3060	
3070	
3080	
3090	
3100	
3110	
3120	
3130	
3140	
3150	
3160	Blank
3170	
3180	
3190	
3200	
3210	
3220	
3230	
3240	
3250	
3260	
3270	
3280	
3290	
3300	
3310	
3320	
3330	
3340	
3350	Process Stopped - Check Event Log For Details
3360	LS SSS: Spare 1
3370	LS SSS: Invalid Starter Model
3380	LS SSS: Phase Loss
3390	LS SSS: Phase Locked Loop Alarm
3400	LS SSS: Power Fault
3410	LS SSS: Run Signal Alarm

TABLE 15 - LIST ALARM CODES (CONT'D)

CODE	CYK QUANTUMLX PRESENT ALARM CODES AS DEFINED BY REGISTERS 43071 - 43080
3420	LS SSS: Current Imbalance
3430	LS SSS: Current Overload
3440	LS SSS: High Instantaneous Current
3450	LS SSS: High Line Voltage
3460	LS SSS: Low Line Voltage
3470	LS SSS: Open Scr
3480	LS SSS: Phase A Shorted Scr
3490	LS SSS: Phase B Shorted Scr
3500	LS SSS: Phase C Shorted Scr
3510	LS SSS: Phase A Inhibit High Temp
3520	LS SSS: Phase B Inhibit High Temp
3530	LS SSS: Phase C Inhibit High Temp
3540	LS SSS: Phase A High Temp
3550	LS SSS: Phase B High Temp
3560	LS SSS: Phase C High Temp
3570	LS SSS: Phase A Open Thermocouple
3580	LS SSS: Phase B Open Thermocouple
3590	LS SSS: Phase C Open Thermocouple
3600	LS SSS: Serial Receive Err
3610	LS SSS: Spare 26
3620	LS SSS: Spare 27
3630	LS SSS: Power Supply Fault
3640	LS SSS: Phase Rotation Fault
3650	LS SSS: Spare 30
3660	LS SSS: Spare 31
3670	LS SSS: Spare 32
3680	HS SSS: Spare 1
3690	HS SSS: Invalid Starter Model
3700	HS SSS: Phase Loss
3710	HS SSS: Phase Locked Loop Alarm
3720	HS SSS: Power Fault
3730	HS SSS: Run Signal Alarm
3740	HS SSS: Current Imbalance
3750	HS SSS: Current Overload
3760	HS SSS: High Instantaneous Current
3770	HS SSS: High Line Voltage
3780	HS SSS: Low Line Voltage
3790	HS SSS: Open Scr
3800	HS SSS: Phase A Shorted Scr
3810	HS SSS: Phase B Shorted Scr
3820	HS SSS: Phase C Shorted Scr
3830	HS SSS: Phase A Inhibit High Temp
3840	HS SSS: Phase B Inhibit High Temp

CODE	CYK QUANTUMLX PRESENT ALARM CODES AS DEFINED BY REGISTERS 43071 - 43080
3850	HS SSS: Phase C Inhibit High Temp
3860	HS SSS: Phase A High Temp
3870	HS SSS: Phase B High Temp
3880	HS SSS: Phase C High Temp
3890	HS SSS: Phase A Open Thermocouple
3900	HS SSS: Phase B Open Thermocouple
3910	HS SSS: Phase C Open Thermocouple
3920	HS SSS: Serial Receive Err
3930	HS SSS: Spare 26
3940	HS SSS: Spare 27
3950	HS SSS: Power Supply Fault
3960	HS SSS: Phase Rotation Fault
3970	HS SSS: Spare 30
3980	HS SSS: Spare 31
3990	HS SSS: Spare 32
4000	Blank
4010	
4020	
4030	
4040	
4050	
4060	
4070	
4080	
4090	
4100	
4110	
4120	Low Auxiliary Analog Input #1 Sensor Warning
4130	High Auxiliary Analog Input #1 Sensor Warning
4140	Low Auxiliary Analog Input #2 Sensor Warning
4150	High Auxiliary Analog Input #2 Sensor Warning
4160	Low Auxiliary Analog Input #3 Sensor Warning
4170	High Auxiliary Analog Input #3 Sensor Warning
4180	Low Auxiliary Analog Input #4 Sensor Warning
4190	High Auxiliary Analog Input #4 Sensor Warning
4200	Low Auxiliary Analog Input #5 Sensor Warning
4210	High Auxiliary Analog Input #5 Sensor Warning
4220	Low Auxiliary Analog Input #6 Sensor Warning
4230	High Auxiliary Analog Input #6 Sensor Warning
4240	Low Auxiliary Analog Input #7 Sensor Warning
4250	High Auxiliary Analog Input #7 Sensor Warning
4260	Low Auxiliary Analog Input #8 Sensor Warning
4270	High Auxiliary Analog Input #8 Sensor Warning

5

TABLE 15 - LIST ALARM CODES (CONT'D)

CODE	CYK QUANTUMLX PRESENT ALARM CODES AS DEFINED BY REGISTERS 43071 - 43080
4280	Low Auxiliary Analog Input #9 Sensor Warning
4290	High Auxiliary Analog Input #9 Sensor Warning
4300	Low Auxiliary Analog Input #10 Sensor Warning
4310	High Auxiliary Analog Input #10 Sensor Warning
4320	Low Auxiliary Analog Input #11 Sensor Warning
4330	High Auxiliary Analog Input #11 Sensor Warning
4340	Low Auxiliary Analog Input #12 Sensor Warning
4350	High Auxiliary Analog Input #12 Sensor Warning
4360	Low Auxiliary Analog Input #13 Sensor Warning
4370	High Auxiliary Analog Input #13 Sensor Warning
4380	Low Auxiliary Analog Input #14 Sensor Warning
4390	High Auxiliary Analog Input #14 Sensor Warning
4400	Low Auxiliary Analog Input #15 Sensor Warning
4410	High Auxiliary Analog Input #15 Sensor Warning
4420	Low Auxiliary Analog Input #16 Sensor Warning
4430	High Auxiliary Analog Input #16 Sensor Warning
4440	Low Auxiliary Analog Input #17 Sensor Warning
4450	High Auxiliary Analog Input #17 Sensor Warning
4460	Low Auxiliary Analog Input #18 Sensor Warning
4470	High Auxiliary Analog Input #18 Sensor Warning
4480	Low Auxiliary Analog Input #19 Sensor Warning
4490	High Auxiliary Analog Input #19 Sensor Warning
4500	Low Auxiliary Analog Input #20 Sensor Warning
4510	High Auxiliary Analog Input #20 Sensor Warning

SECTION 6 - TROUBLESHOOTING

When there is a problem that makes no sense due to unexplainable things happening, check the following:

1. Is the panel powered by an isolating power source such as a control transformer in the starter panel?
2. Is the panel powered from a lighting or utility panel?
3. It is important to know if the unit ever worked properly.
4. If the unit used to work properly, try to determine when the problem first showed up.
5. It is important to know if the problem occurs randomly, frequently, or all the time.
6. Check what the temperature is in the engine room and at the panel. Is it very hot or very cold? Make sure that the motor is not blowing exhaust air on the control panel.
7. If it just started to act up, then check if there was recently a severe lightning storm, fire, flood, or a plant accident. If any of the following conditions are possible, then check for it:

Has any water, refrigerant, or oil leaked into the panel or conduit?
8. If it just started to act up, then check if anything was recently changed in the system (i.e. software or hardware.)
9. If it just started to act up, then check if any service was recently done to the chiller or its electrical system?
10. If there is communication wiring connecting the panel to another panel or device, then check the following:
 - If the Quantum™ LX is unexplainably shutting down, try disconnecting the communications cable to see if the problem goes away.
 - Check if the communications cable shields are tied to machine ground at only one location. For a PLC or Opto22 based system, the shield should normally be tied only at the PLC or Opto22 panel. For dual sequencing machines, the shield should only be tied to ground in one panel, typically the “Lead” machine.
 - Check that you are using the Frick recommended communications cable.
11. If this is an older plant, has the plant wiring been brought up to code?
12. Do you have power wiring mixed with control, sensor or communications wiring?
13. Check that the starter panel is grounded to the plant transformer. There are usually four wires: 3 for the 3 phases and 1 for plant ground.
14. Check that the motor is grounded to the starter panel. There are usually four wires: 3 for the phases and 1 for ground.
15. Ensure that one side of the motor current transformer is grounded in the motor starter panel. The wire to the control panel terminal #2 is usually the only one grounded.
16. Check that the temperature transducers are properly grounded. The temperature probes usually have two short wires coming out of the sensor, and are tied to a shielded cable at the thermal well head. The shield is insulated at the temperature probe and grounded at the panel end.
17. Check if one of the temperature probes has a signal wire shorted to machine ground. To do this, first pull the orange plug from the micro board and then use a DVM and check each white wire to machine ground and each black wire to machine ground.
18. Check that all inductive loads (i.e. coils, solenoids, or relays, etc.) connected to the I/O output modules have surge suppressors across them, preferably at the devices. Most of the larger factory installed inductive loads should have surge suppressors as well.
19. If the chiller control settings unexplainably change modes, it may be a noise problem affecting the keypad’s input circuit. Check if it works OK with the keypad cable disconnected. If it works OK, then check the grounding as described above. If the grounding is OK then replace the keypad.
20. Make sure that you have a continuous ground back to the power source. The ground connection must be copper. A conduit ground will not work. Do not drive a ground stake at the chiller since extraneous currents will be attracted to the chiller.

21. Make sure that there is no AC wiring lying next to the printed circuit board.
22. Unexplainable chiller auxiliary failures are usually indicative of noise due to wiring problems (i.e. incorrect earth grounds, mixed power and control wiring, unsuppressed coils, etc)
23. If the chiller is unexplainably shutting down, check if the machine shares control transformer power with something else. Make sure each chiller has its own isolation transformer in the motor control center off the three-phase bus with the secondary properly grounded.

The following factors can be used to convert from English to the most common SI Metric values.

TABLE 16 - SI METRIC CONVERSION

MEASUREMENT	MULTIPLY ENGLISH UNIT	BY FACTOR	TO OBTAIN METRIC UNIT
Capacity	Tons Refrigerant Effect (ton)	3.516	Kilowatts (kW)
Power	Horsepower	0.7457	Kilowatts (kW)
Flow Rate	Gallons / Minute (gpm)	0.0631	Liters / Second (l/s)
Length	Feet (ft)	0.3048	Meters (m)
	Inches (in)	25.4	Millimeters (mm)
Weight	Pounds (lbs)	0.4538	Kilograms (kg)
Velocity	Feet / Second (fps)	0.3048	Meters / Second (m/s)
Pressure Drop	Feet of Water (ft)	2.989	Kilopascals (kPa)
	Pounds / Square Inch (psi)	6.895	Kilopascals (kPa)

TEMPERATURE

To convert degrees Fahrenheit (°F) to degrees Celsius (°C), subtract 32° and multiply by 5/9 or 0.5556.

Example: $(45.0^{\circ}\text{F} - 32^{\circ}) \times 0.5556 = 27.2^{\circ}\text{C}$

To convert a temperature range (i.e., a range of 10°F) from Fahrenheit to Celsius, multiply by 5/9 or 0.5556.

Example: $10.0^{\circ}\text{F range} \times 0.5556 = 5.6^{\circ}\text{C range}$



P.O. Box 1592, York, Pennsylvania USA 17405-1592
Copyright © by Johnson Controls 2011

Form 160.82-OM1 (813)
Issue Date: August 30, 2013
Supersedes: 160.82-OM1 (611)

800-861-1001
www.johnsoncontrols.com

Subject to change without notice. Printed in USA
ALL RIGHTS RESERVED