



**YCWS
WATER COOLED LIQUID CHILLER**



**91 THROUGH 216 TONS
320kW THROUGH 760 kW
60Hz
STYLE B**

Table of Contents

Introduction	3
Specifications	4
Accessories & Options	7
Unit Nomenclature	9
Design Parameters	10
Refrigerant Flow Diagram	11
Pressure Drop Curves	12
Selection Data	14
Ratings English (R-22)	16
Ratings SI (R-22)	18
Ratings- Brine (30 % Ethylene Glycol) English (R-22)	20
Ratings- Brine (30 % Ethylene Glycol) SI (R-22)	22
Ratings- Brine (30 % Propylene Glycol) English (R-22)	24
Ratings- Brine (30 % Propylene Glycol) SI (R-22)	26
Part Load Ratings	28
Glycol Correction Factors	30
Physical Data	32
Isolator Selection Data	33
Isolator Details	34
Sound Data	35
Dimensions - YCWS0100 - English	36
Dimensions - YCWS0120 - English	38
Dimensions - YCWS0140 - English	40
Dimensions - YCWS0180 - English	42
Dimensions - YCWS0200 - English	44
Dimensions - YCWS0220 - English	46
Dimensions - YCWS0240 - English	48
Dimensions - YCWS0100 - SI	50
Dimensions - YCWS0120 - SI	52
Dimensions - YCWS0140 - SI	54
Dimensions - YCWS0180 - SI	56
Dimensions - YCWS0200 - SI	58
Dimensions - YCWS0220 - SI	60
Dimensions - YCWS0240 - SI	62
Electrical Data	64
Electrical Notes	68
Customer Wiring Data	70
Typical Control Panel Wiring	72
Application Data	74
Guide Specifications	75

Introduction

York YCWS Water Cooled Screw Chillers



YORK YCWS Water-Cooled models provide chilled water for all air conditioning applications that use central station air handling or terminal units. They are completely self-contained and are designed for indoor (new or retrofit) installation. Each unit includes accessible semi-hermetic screw compressors, a liquid cooler, water cooled condenser, and a user-friendly, diagnostic Microcomputer Control Center all mounted on a rugged steel base. The units are produced at an ISO 9001 registered facility. The YCWS chillers are rated in accordance with ARI Standard 550/590.

Specifications

GENERAL

The Liquid Chiller will be completely assembled with all interconnecting refrigerant piping and internal wiring, ready for field installation.

The unit will be pressure-tested, evacuated, and charged with Refrigerant-22, and York 'L' (POE) synthetic oil. There will be an operational test, with water flowing through the cooler, to check that each control device operates correctly.

The unit can be covered with an optional coat of Caribbean Blue enamel. Units are designed in accordance with NFPA 70 (National Electric Code), ASHRAE/ANSI 15 Safety Code for Mechanical Refrigeration. All units are produced at an ISO 9001 registered facility. All YCWS chillers are rated in accordance with ARI Standard 550/590 at ARI conditions.

SEMI-HERMETIC YORK SCREW COMPRESSORS

- An ideal synergy of expertise, sister division FRICK™s Industrial Refrigeration Compressor Engineers as integral members on YORK™s Chiller Design Team, has resulted in a world class compressor with unequalled performance.
- Continuous function, microprocessor controlled, 3- way proportional Capacity Control Valve provides regulated output pressure independent of valve input pressure for a stable, smooth, and precise match of compressor capacity to cooling load to 10% of chiller capacity.
- Automatic spring return of capacity control valve to minimum load position ensures compressor starting at minimum motor load. Internal discharge check to prevent rotor backspin upon shutdown.
- Acoustically tuned, internal discharge gas path eliminates objectionable noise at the source, while optimizing flow for maximum performance.
- Reliable suction gas cooled, high efficiency, accessible hermetic motor with APT2000 type magnet wire and redundant overload protection using both thermistor and current overload protection.
- Suction gas screen and serviceable, 0.5 micron full flow oil filter within the compressor housing.
- Cast iron compressor housing precisely machined for optimal clearances and superb efficiency. Entire compressor, from suction to discharge has a Design Working

Pressure of 450psig (31 bar).

- 350W compressor body cartridge heater.
- Each compressor will be mounted on isolator pads to reduce transmission of vibration to the rest of the unit.

COOLER

The dual-circuit cooler will be the direct-expansion type, with refrigerant in the tubes and chilled liquid flowing through the baffled shell. The design working pressure of the shell (liquid) side will be 150 PSIG (10.3 bar), and 300 PSIG (26.7 bar) for the tube (refrigerant) side.

The cooler will be constructed and tested in accordance with the applicable sections of the ASME Pressure Vessel Code, Section VIII, Division (1). The water side will be exempt per paragraph U-1, (°C)(6).

The water baffles will be constructed of galvanized steel to resist corrosion. The removable heads will allow access to the internally enhanced, seamless, copper tubes. Vent and drain connections will be included.

The cooler will be covered with 3/4" (19.1 mm) flexible, closed-cell, foam insulation (K = 0.25).

CONDENSER

The condenser is a cleanable thru-tube type with steel shell, copper tubes, removable water heads, and includes integral subcooling. Refer to PHYSICAL DATA for design working pressures. The shell will be constructed and tested in accordance with section VII, division 1 of the ASME pressure-vessel code. The water side is exempt per paragraph U-1 (°C) of section VIII, division 1 of the ASME pressure-vessel code. The condenser is equipped with relief valves and will hold the full refrigerant charge for pumpdown.

REFRIGERANT CIRCUIT

Two independent refrigerant circuits will be furnished on each unit. All piping will be ACR copper with brazed joints. The liquid line will include: a shutoff valve with charging port; sightglass with moisture indicator; thermal expansion valve; solenoid valve; and high-absorption removable-core filter drier. The entire suction line and the liquid line between the expansion valve and the cooler will be insulated with flexible, closed-cell, foam insulation.

POWER AND CONTROL PANELS

All controls and motor starting equipment necessary for unit operation shall be factory wired and function tested. The panel enclosures shall be designed to IP32 (NEMA 1) and manufactured from powder-painted galvanized

steel.

The Power and Control Panel shall be divided into a power section for each electrical system, a common input section and a control section.

Each power panel shall contain:

Compressor starting contactors, control circuit serving compressor capacity control, compressor contactor coils and compressor motor overloads. The compressor motor overloads contain current transformers which sense each phase, as an input to the microprocessor, to protect the compressor motors from damage due to: low input current, high input current, unbalanced current, single phasing, phase reversal, and compressor locked rotor.

The common input section shall contain:

The control supply transformer providing 115V, customer relay board and control circuit switch disconnect/emergency stop device.

The control section shall contain:

On/Off rocker switch, microcomputer keypad and display, microprocessor board, I/O expansion board, relay boards, and 24V fused power supply board.

MICROPROCESSOR CONTROLS

Fuzzy Logic control will be incorporated in the YCWS range of chillers. Fuzzy Logic allows the control system to monitor several key variables to provide tighter, more stable chilled water temperature control. The control system monitors the leaving chilled water temperature to track where it has been, where it is now, how fast it is moving, and accurately adjusts the chiller operation in anticipation of expected performance to minimize hunting and save energy.

The microprocessor shall have the following functions and displays:

- A liquid crystal 40 character display with text provided on two lines and light emitting diode backlighting for outdoor viewing.
- A color-coded, 35 button, sealed keypad with sections for Display, Entry, Setpoints, Clock, Print, Program, and Unit On/Off Switch.

The standard controls shall include: brine chilling or thermal storage, automatic pumpdown, run signal contacts, demand load limit form external building automation system input, remote reset liquid temperature reset input, unit alarm contacts, chilled liquid pump control, automatic reset after power failure, automatic system optimization to match operating conditions, software stored in nonvolatile

memory (EPROM) to eliminate chiller failure due to AC power failure.

The microprocessor can be directly connected to a YORK ISN Building Automation System via the standard onboard RS485 communications port. This option also provides open system compatibility with other communications networks.

Programmed Setpoints shall be retained in a lithium battery backed RTC with a memory of five years.

Display - In Metric ($^{\circ}\text{C}$ and Bars) or English ($^{\circ}\text{F}$ and PSIG) units, and for each circuit:

- Return and leaving chilled liquid
- Day, date and time. Daily start/stop times. Holiday and Manual Override status.
- Compressor operating hours and starts. Automatic or manual lead/lag. Lead compressor identification.
- Run permissive status. No cooling load condition. Compressor run status.
- Anti-recycle timer and anti-coincident start timer status per compressor.
- Suction (and suction superheat), discharge, and oil pressures and temperatures per System.
- Percent full load compressor motor current per phase and average per phase. Compressor capacity control valve input steps.
- Cutout status and setpoints for: supply fluid temperature, low suction pressure, high discharge pressure and temperature, high oil temperature, low and high current, phase rotation safety, and low leaving liquid temperature.
- Unloading limit setpoints for high discharge pressure and compressor motor current.
- Liquid pull-down rate sensitivity (0.3°C to 3.0°C [0.5°F to 5°F]/minute in 0.05°C [0.1°F] increments).
- Status of: evaporator heater, load and unload timers, chilled water pump.
- Out of range message.
- Up to 6 fault shut down conditions.
- Standard Display Language is English, with an Option for Spanish.

Entry - Enter set point changes, cancel inputs, advance-day, change AM/PM.

Set Points - Chilled liquid temperature, chilled liquid range, remote reset temperature range.

Clock - Time, daily or holiday start/stop schedule, manual override for servicing.

Print - Operating data or system fault shutdown history for last six faults. Printouts through an RS-232 port via a separate printer (by others).

Program -

- Low leaving liquid temperature cutout, 300 to 600 second anti-recycle timer, lag compressor start time delay, and average motor current unload point. Liquid temperature setpoint reset signal from YORK ISN or

Specifications (Continued)

building automation system (by others) via:

- Pulse width modulated (PWM) input for up to 40°F(22°C) total reset as standard.
- Optional Building Automation System interface input card for up to 11.1°C (20°F) reset using a: 4 to 20 mA, 0 to 10 Vdc input, or discrete reset input.

NOTE: The Standard MicroPanel can be directly connected to a YORK ISN Building Automation System via the standard onboard RS485 communication port. This Option also provides open system compatibility with other communications networks (BACnet™ & LONMARK™ via interface through standard onboard 485 or 232 port and an external YorkTalk Translator.

- Additional functions (password protected) for programming by a qualified service technician:

Cutouts for low suction pressure, high discharge pressure, high oil temperature.

Refrigerant type.

High discharge pressure unload setpoint.

Compressor motor current percent limit.

Accessories & Options

ALTERNATIVE REFRIGERANTS - Contact your nearest YORK office for information and availability on alternative HFC refrigerants.

ELECTRICAL OPTIONS:

MULTIPLE POINT POWER SUPPLY CONNECTION - Standard field power wiring connection on all models is Multiple Point Power Connection to factory provided Terminal Blocks. Two field supplied electrical power circuits with appropriate branch circuit protection provide power to each of two motor control center cabinets, located on either side of the Control panel on the front of the chiller. Each cabinet contains starter elements for one compressor.

Optional to the Terminal Blocks for field power connection are Non-Fused Disconnects or Circuit Breaker Switches with external, lockable handles.

SINGLE POINT POWER CONNECTION - (Factory Mounted) An optional configuration for field connection of a single electrical circuit to: either Terminal Block or Non-Fused Disconnect Switch with lockable external handle (in compliance with Article 440 of N.E.C., to isolate unit power supply for service). Factory wiring is provided from the Terminal Block or Disconnect Switch to Factory supplied individual system Circuit Breakers, Non-Fused Disconnect switch with external, lockable handle or J Class Fuses/Fuse Block in each of the two compressor motor control centers. (Note: Single Point Non-Fused Disconnect Switch will not be supplied with individual system Non Fused Disconnect Switches with external, lockable handles in each of the two compressor motor control centers).

Non-Fused Disconnect Switch with fuses (200 & 575V) or Circuit Breakers (200, 380, & 460V) are used for applications where customers have a requirement for single point wiring with high "fault current" withstanding capability. This option provides between 50Ka and 65Ka withstand protection to the equipment.

BUILDING AUTOMATION SYSTEM INTERFACE – Provides means to reset the leaving chilled liquid temperature or percent full load amps (current limiting) from the BAS (**Factory Mounted**):

- Printed circuit board to accept 4 to 20 milliamp, 0 to 10 DC, or dry contact closure input from the BAS.
- A YORK ISN Building Automation System can provide a Pulse Width Modulated (PWM) signal direct to the standard control panel via the standard onboard RS485 port.

FLOW SWITCH – The flow switch or its equivalent must be furnished with each unit. 150 PSIG (10.5 bar) DWP – For standard units. Johnson Controls model F61MG-1C Vapor-proof SPDT, NEMA 4X switch (150 PSIG [10.5 bar] DWP), -20°F to 250°F- (29°C to 121°C), with 1" NPT connection for upright mounting in horizontal pipe. (**Field mounted**)

DIFFERENTIAL PRESSURE SWITCH - alternative to the above mentioned flow switch. Pretemco model DPS 300A-P4OPF-82582-S (20.7Bar max working pressure). Spdt 5 amp 125/250 vac switch. Range: 0 - 2.8Bar, deadband: 0.003 - 0.005Bar, with 1/4 npte pressure connections

LANGUAGE LCD AND KEYPAD - Standard display language and keypad is in English. Spanish is available as an option.

HANDHELD PRINTER - Handheld printer for obtaining printout of unit operating and history data. (**Field Mounted**)

MULTIPLE UNIT SEQUENCE CONTROL (Field Mounted) - Sequencing Control with automatic unit sequencing. Necessary items for operation and control of up to eight units with parallel water circuits. Includes software and mixed liquid temperature sensor (interconnecting wiring by others).

PRESSURE VESSEL CODES - Coolers and condensers can be supplied in conformance with the following pressure codes:A.S.M.E. (Standard)

FINAL PAINT OVERSPRAY - Overspray painting of unit after assembly.

SERVICE ISOLATION VALVE: Service suction isolation valve added to unit per system (**Factory Mounted**)

BUY AMERICAN ACT COMPLIANCE - In keeping with the "Buy America Act", products will be comprised of 50% U.S. content and manufactured (final assembly) in the U.S.A.

ACCESSORIES:

FLANGES (Weld Type) – Consists of 150 PSI (10.5 bar) standard cooler (150 lb) R.F. flanges to convert to flanged cooler-connections and includes companion flanges. (**Factory Mounted**)

FLANGES (Victaulic Type) – Consists of (2) Flange adapter for grooved end pipe [standard 150 psi(10.5 bar)

Accessories & Options - Continued

cooler]. Includes companion flanges. **(Field mounted)**

VIBRATION ISOLATION:

- **Neoprene Isolation** – Recommended for normal installations. Provides very good performance in most applications for the least cost. **(Field mounted)**
- **1" Spring Isolators** – Level adjustable, spring and cage type isolators for mounting under the unit base rails. 1" nominal deflection may vary slightly by application. **(Field mounted)**
- **2" Sesmic Isolators** - Restrained Spring-Flex Mountings incorporate a rugged welded steel housing with vertical and horizontal limit stops. Housings designed to withstand a minimum 1.0g accelerated force in all directions to 2". Level adjustable, deflection may vary slightly by application. **(Field Mounted)**

ALTERNATIVE CHILLED FLUID APPLICATIONS:

Standard water chilling application range is 40°F to 50°F (4.4°C to 10°C) Leaving Chilled Water Temperature. To protect against nuisance safety trips below 40°F (4°C) and reduce the possibility of cooler damage due to freezing during chiller operation, the unit microprocessor automatically unloads the compressors at abnormally low suction temperature (pressure) conditions , prior to safety shutdown.

- **Process Brine Option** – Process or other applications requiring chilled fluid below 40°F (4.4°C) risk water freezing in the evaporator, typically overcome by using antifreeze. For these applications, the chiller system incorporates brine (ethylene or propylene glycol solution), and the system design Leaving Chilled Fluid Temperature must be provided on the order form to ensure proper factory configuration.
- **Thermal Storage Option** – Thermal Storage requires special capabilities from a chiller, including the ability to 'charge' an ice storage tank, then possibly automatically reset for operation at elevated Leaving Chilled Fluid Temperatures as required by automatic building controls. The Thermal Storage Option provides Ice Storage duty Leaving Chilled Fluid setpoints from 25°F to 15°F (-4°C to -10°C) minimum during charge cycle, with a Reset range of 36°F (20°C) supply fluid temperature.

Unit Nomenclature

Nomenclature

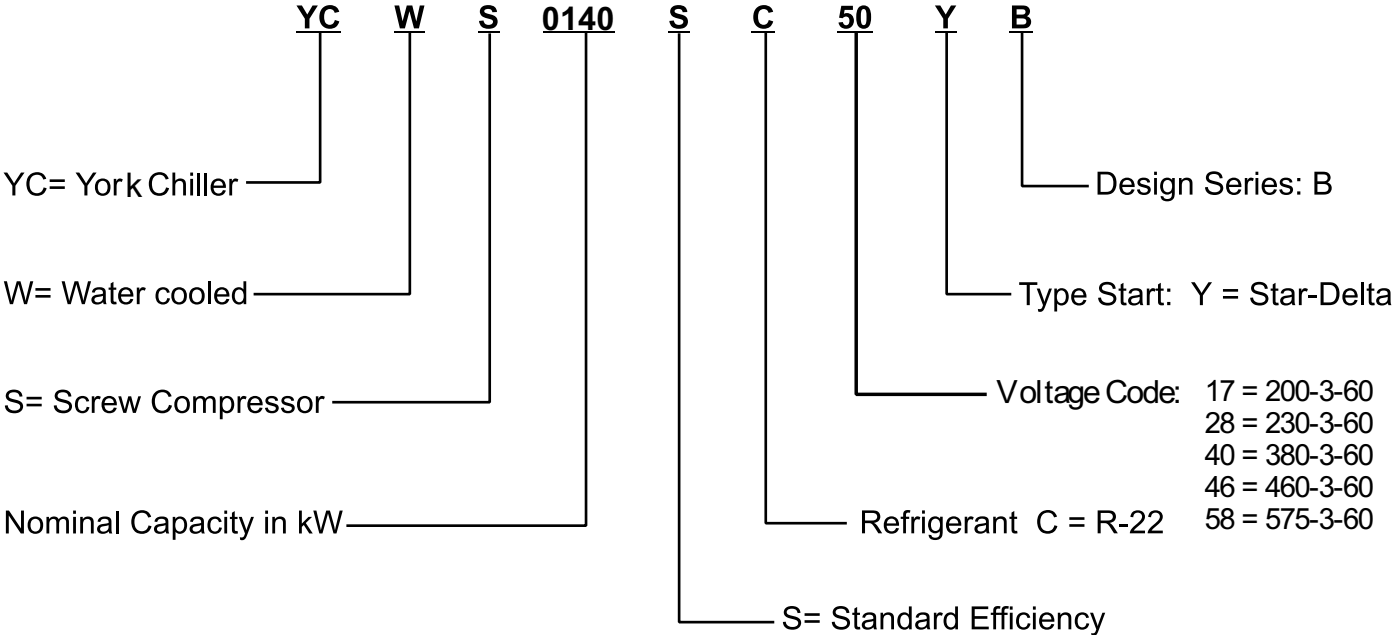

Design Parameters

ENGLISH

YCWS	0100SC	0120SC	0140SC	0180SC	0200SC	0220SC	0240SC
Min. Cooler Water Flow - GPM	200	200	200	260	260	300	300
Max. Cooler Water Flow - GPM	506	506	506	695	695	830	830
Min. Cond. Water Flow - GPM	193	193	193	330	330	330	330
Max. Cond. Water Flow - GPM	645	645	645	1050	1050	1050	1050
Min. Lvg. Liquid Temp. - °F	40	40	40	40	40	40	40
Max. Lvg. Liquid Temp. - °F	50	50	50	50	50	50	50
Min. Ent. Cond. Water Temp - °F	75	75	75	75	75	75	75
Max. Ent. Cond. Water Temp - °F	95	95	95	95	95	95	95
Min. Equipment Room Temp. - °F	40	40	40	40	40	40	40
Max. Equipment Room Temp. - °F	115	115	115	115	115	115	115

SI

YCWS	0100SC	0120SC	0140SC	0180SC	0200SC	0220SC	0240SC
Min. Cooler Water Flow - l/sec	12.6	12.6	12.6	16.4	16.4	18.9	18.9
Max. Cooler Water Flow - l/sec	31.9	31.9	31.9	43.8	43.8	52.4	52.4
Min. Cond. Water Flow - l/sec	12.2	12.2	12.2	20.8	20.8	20.8	20.8
Max. Cond. Water Flow - l/sec	40.7	40.7	40.7	66.2	66.2	66.2	66.2
Min. Lvg. Liquid Temp. - °C	4.4	4.4	4.4	4.4	4.4	4.4	4.4
Max. Lvg. Liquid Temp. - °C	10.0	10.0	10.0	10.0	10.0	10.0	10.0
Min. Ent. Cond. Water Temp - °C	23.8	23.8	23.8	23.8	23.8	23.8	23.8
Max. Ent. Cond. Water Temp - °C	35.0	35.0	35.0	35.0	35.0	35.0	35.0
Min. Equipment Room Temp. - °C	4.4	4.4	4.4	4.4	4.4	4.4	4.4
Max. Equipment Room Temp. - °C	46.1	46.1	46.1	46.1	46.1	46.1	46.1

Refrigerant Flow Diagram

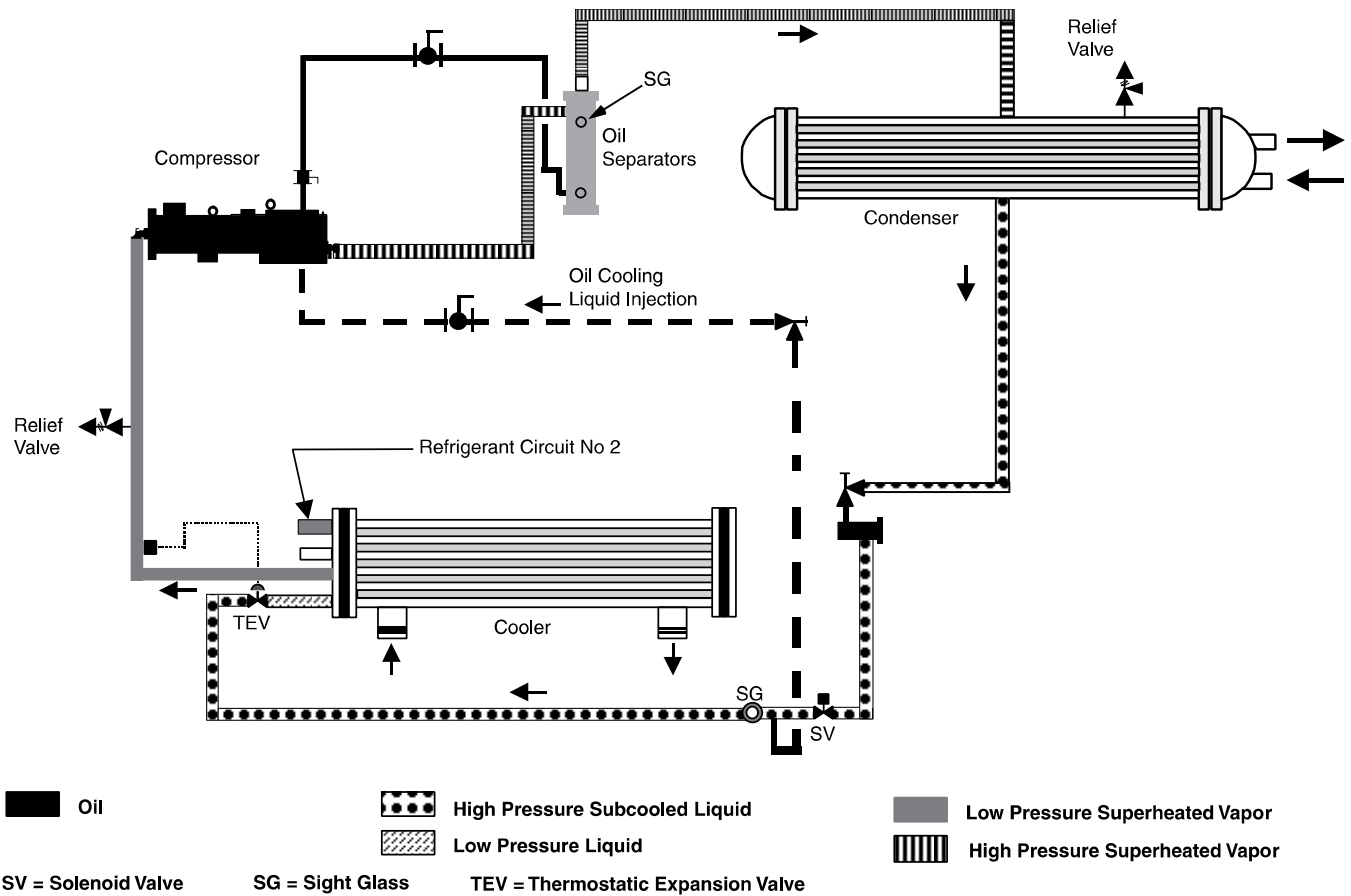

Low-pressure liquid refrigerant enters the cooler tubes and is evaporated and superheated by the heat energy absorbed from the chilled liquid passing through the cooler shell. Low-pressure vapor enters the compressor where pressure and superheat are increased. High-pressure vapor is passed through the oil separator where heat is rejected to the condenser water passing through the tubes. The fully condensed and subcooled liquid leaves the condenser and enters the expansion valve, where pressure reduction and further cooling take place. The low pressure liquid refrigerant then returns to the cooler. Each refrigerant circuit utilizes liquid injection, maintaining efficient oil temperature operation within the compressor.

FIG. 1 - REFRIGERANT FLOW DIAGRAM

Pressure Drop Curves

FIGURE 1 - COOLER WATER PRESSURE DROP CURVES (ENGLISH)

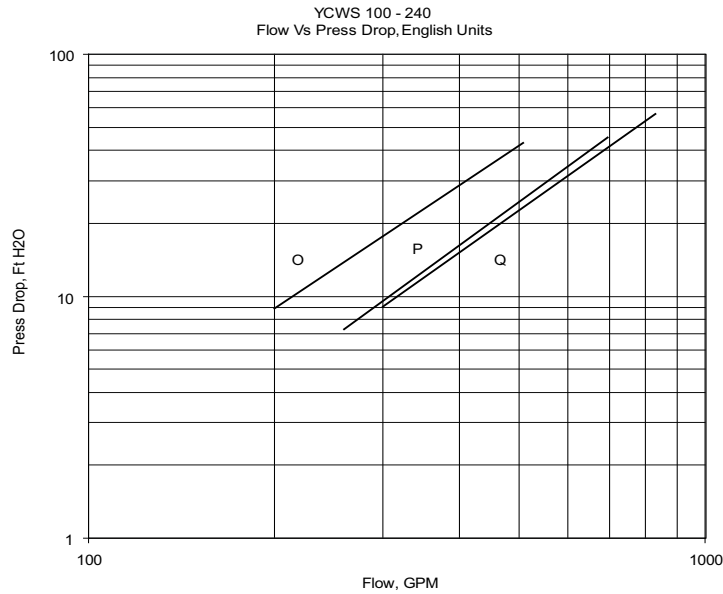

YCWS Model Number	Cooler
0100SC, 0120SC, 0140SC	O
0180SC, 0200SC	P
0220SC, 0240SC	Q

FIGURE 2 - CONDENSER WATER PRESSURE DROP CURVES (ENGLISH)

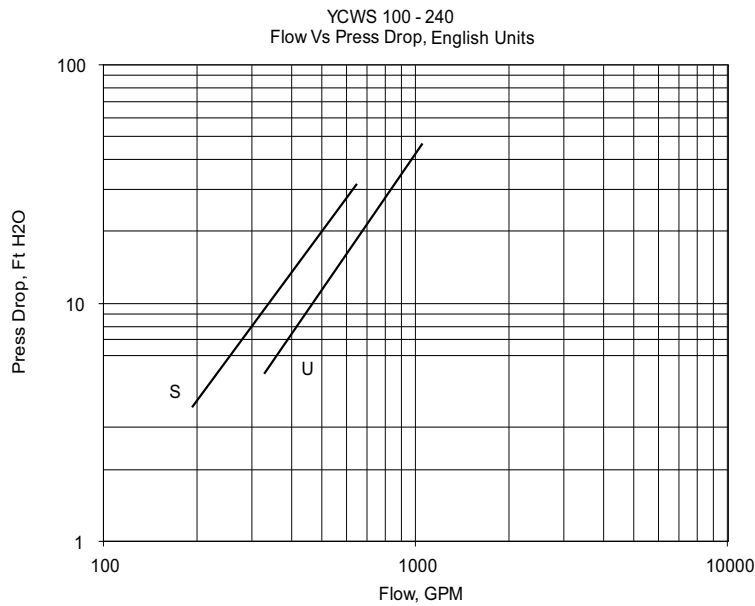

YCWS Model Number	Condenser
0100SC, 0120SC, 0140SC	S
0180SC, 0200SC 0220SC, 0240SC	U

FIGURE 2 - COOLER WATER PRESSURE DROP CURVES (SI)

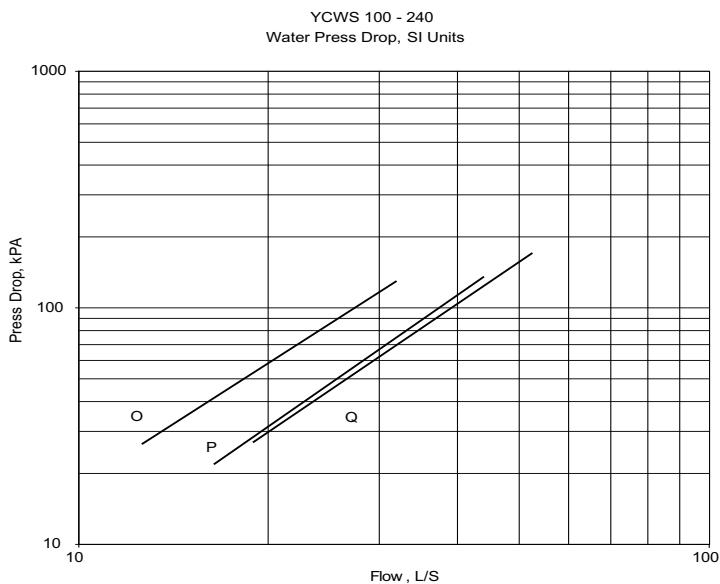

YCWS Model Number	Cooler
0100SC, 0120SC, 0140SC	O
0180SC, 0200SC	P
0220SC, 0240SC	Q

FIGURE 3 - CONDENSER WATER PRESSURE DROP CURVES (SI)

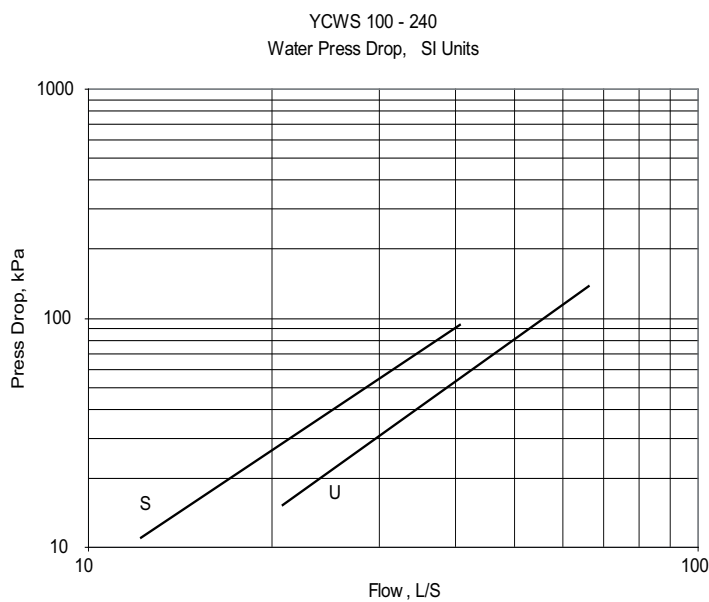

YCWS Model Number	Condenser
0100SC, 0120SC, 0140SC	S
0180SC, 0200SC 0220SC, 0240SC	U

Selection Data

GUIDE TO SELECTION

Complete water chilling capacity ratings for YORK YCWS chillers are shown on the following pages to cover the majority of job requirements. For any application beyond the scope of this Engineering Guide, consult your nearest YORK office.

RATINGS – All YCWS 50Hz ratings are in accordance with ARI Standard 550/590, at the ARI standard conditions. Ratings not at standard ARI conditions are rated in accordance with ARI rating procedures. These ratings may be interpolated but should not be extrapolated.

YCWS WATER COOLED CHILLERS

To select a chiller the following data must be known:

1. Design cooling capacity kW
2. Entering and leaving chilled water temperatures
3. Entering and leaving condenser water temperatures
4. Chilled water flow l/s if one of the temperatures in item 2 is unknown
5. Condenser water flow l/s if one of the temperatures in item 3 is unknown
6. Cooler and condenser fouling factors

Determine the capacity from:

$$\text{kW} = \text{l/s chilled water} \times \text{°C range} \times 4.18$$

Determine heat rejection from:

$$\text{kW} = \text{l/s condenser water} \times \text{°C range} \times 4.18$$

YCWS SAMPLE SELECTION

An R22 chiller is required to cool 21l/s of water from 12°C to 7°C. The condenser leaving water is 35°C with a 5°C range.

The required fouling factor for the evaporator is 0.044m² °C/kW and for the condenser 0.088m² °C/kW.

FIND: The required Unit size, Capacity, kW input power, Cooler and Condenser pressure drops.

SOLUTION:

1. Chilled water range = 12 - 7 = 5°C
2. Capacity kW = l/s x range x 4.18
21 x 5 x 4.18 = 438.9kW
3. Select chiller model from capacity table page:12
UNIT : **YCWS 0503SC**
Cooling Capacity (kW_o) = 448.3
Input Power (kW_i) = 100.4
COP = 4.5
4. The fouling factors required are different to the standard ARI condition, for alternative fouling factors consult the tables below or contact your York repre-

sentative. Actual condenser heat rejection should be computed after the kW's have been determined.

EVAPORATOR

Fouling Factor m ² °C/kW	Cooling Capacity	Compressor Input Factor
0.018	1.00	1.00
0.044	0.991	0.998

Note: Standard ARI fouling factor 0.018 m² °C/kW

CONDENSER

Fouling Factor m ² °C/kW	Cooling Capacity	Compressor Input Factor
0.044	1.000	1.000
0.088	0.992	1.012

Note: Standard ARI fouling factor 0.044 m² °C/kW

5. Net Cooling Capacity = kW_o x Fouling factor of Evaporator x Fouling factor of Condenser
= 448.3 x 0.991 x 0.992
= 440.7 kW
Net kW Input = kW input Fouling factor of Evaporator x kW input Fouling factor of Condenser
= 100.4 x 0.998 x 1.012
= 101.4 kW
6. The heat rejection at the required fouling conditions will be: 440.7 + (101.4 x 0.95*) = 537.03

* 5% Radiation heat loss through compressor and motor housing

7. The chilled water flow required to satisfy the capacity corrected for the fouling factor conditions is:
Actual capacity kW / (Range °C x 4.18)
= 440.7 / (5 x 4.18) = 21.1 l/s
8. Determine the cooler water pressure drop from Page 9, line K = 53 kPa
9. Determine the condenser water flow = Heat rejection kW / (Range °C x 4.18)
537.03 / (5 x 4.18) = 25.7 l/s
10. Determine the condenser water pressure drop from Page 9, line F = 62 kPa

GLYCOL SAMPLE SELECTION

1. From page 18 determine the percentage concentration of glycol required for the design glycol leaving temperature.

2. Determine capacity required from the following formula: Capacity (kW required)
= Litre/Sec x Temperature Range °C
Brine factor (Figure 4 or Figure 6)
 3. Enter the appropriate set of rating tables at the required leaving glycol temperature and the condenser water-leaving temperature. Check selection for minimum glycol flow rate.
 4. When a suitable unit is obtained, determine the corresponding kW. Note, the kW ratings are for a 30% ethylene glycol or propylene, therefore the kW ratings require adjusting by the correction factor given in Table 1, page 19 for the other concentrations of ethylene or propylene glycol.
 5. After applying any fouling factor correction, determine condenser heat rejection and condenser water quantity as follows: Condenser heat rejection =
Capacity kW + (Input kW in x 0.95)
- Note: Use corrected capacity and input for the required glycol concentration
6. Condenser water flow may then be determined from the following:
Condenser water l/s =
Condenser heat rejection kW x 0.239
Condenser water range °C

SAMPLE SELECTION

It is required to cool 40% by weight propylene glycol from -3°C to -6°C with a flow rate of 15.8 l/s. the condensing water being at 30°C to 35°C. A fouling factor of 0.044 m² °C/kW is specified for the cooler.

SOLUTION

1. For ethylene glycol at minus 6°C the recommended concentration is 35% (Figure 3), but the required concentration is 40%, therefore the brine factor is 0.254, (Figure 4).
2. Required Capacity (kW)
= L/s x temperature range
°C Brine factor
= 15.8 x (-6 - -3) 0.245
= 186.6kW
3. **YCWS 0423SC** gives cooling capacity of 208.9kW with an input power of 76.6kW
4. Adjust capacity and input for 40% ethylene glycol. See

Table 1

$$\begin{aligned} \text{Capacity} &= 208.9 \times 0.95 = 208 \text{ kW} \\ \text{Input} &= 76.6 \times 0.998 = 76.5 \text{ kW} \end{aligned}$$

5. Adjust new unit capacity and input for 0.044 m² °C/kW fouling factor on cooler. See Table 1.
Capacity = 208 x 0.991 = 206.1 kW
Input = 76.5 x 0.998 = 76.3kW
6. Obtain ethylene glycol pressure drop through **YCWS 0423SC** cooler. First, obtain the pressure drop for an equivalent quantity of water, (15.8 l/s). See Figure 1.

$$\begin{aligned} \text{Pressure drop, water} &= 30\text{kPa} \\ \text{Multiply water pressure drop by ethylene glycol pressure drop factor.} \\ \text{Ethylene glycol pressure drop factor (Figure 5)} &= 1.34 \\ \text{(Taken at mean brine temperature)} \end{aligned}$$

$$\begin{aligned} \text{Pressure drop, ethylene glycol} \\ &= 30\text{kPa} \times 1.34 = 40.2 \text{ kPa ethylene glycol} \end{aligned}$$

7. The condenser water requirements are obtained as follows: Condenser heat rejection =
206.1 + (76.3 x 0.95) = 278.6 kW
Condenser water flow rate (l/s) =
278.6 kW x 0.239 = 13.31 l/s
5°C

Check that the flow rate is within the condenser flow limitations.

8. Obtain water pressure drop through **YCWS 0423SC** condenser, See Figure 2, 30 kPa.

Ratings English (R-22)

MODEL: YCWS0100SC

IPLV= 18.8

LCWT (°F)	LEAVING CONDENSER WATER TEMPERATURE (°F)											
	85.0				95.0				105.0			
	TONS	KW	MBH	EER	TONS	KW	MBH	EER	TONS	KW	MBH	EER
40.0	89.5	63.3	1289.0	17.0	84.2	71.5	1254.0	14.1	78.7	80.7	1220.0	11.7
42.0	93.1	63.4	1334.0	17.6	87.7	71.8	1297.0	14.7	82.1	80.9	1261.0	12.2
44.0	96.9	63.5	1380.0	18.3	91.3	72.0	1342.0	15.2	85.6	81.1	1304.0	12.7
45.0	98.9	63.6	1403.0	18.7	93.2	72.2	1364.0	15.5	87.4	81.2	1326.0	12.9
46.0	100.8	63.6	1426.0	19.0	95.1	72.3	1388.0	15.8	89.2	81.4	1348.0	13.2
48.0	104.8	63.5	1474.0	19.8	99.0	72.5	1435.0	16.4	92.9	81.7	1394.0	13.7
50.0	108.9	63.4	1523.0	20.6	102.9	72.7	1483.0	17.0	96.7	81.9	1440.0	14.2

MODEL: YCWS0120SC

IPLV= 18.2

LCWT (°F)	LEAVING CONDENSER WATER TEMPERATURE (°F)											
	85.0				95.0				105.0			
	TONS	KW	MBH	EER	TONS	KW	MBH	EER	TONS	KW	MBH	EER
40.0	108.0	75.6	1554.0	17.1	101.7	85.6	1513.0	14.3	95.3	96.7	1473.0	11.8
42.0	112.4	75.8	1607.0	17.8	106.0	85.9	1564.0	14.8	99.4	96.9	1523.0	12.3
44.0	116.9	76.0	1662.0	18.5	110.3	86.2	1618.0	15.4	103.5	97.2	1574.0	12.8
45.0	119.2	76.0	1689.0	18.8	112.5	86.3	1645.0	15.6	105.7	97.3	1600.0	13.0
46.0	121.5	76.0	1717.0	19.2	114.8	86.5	1672.0	15.9	107.8	97.5	1626.0	13.3
48.0	126.3	76.0	1775.0	19.9	119.4	86.7	1728.0	16.5	112.2	97.8	1680.0	13.8
50.0	131.2	75.9	1833.0	20.7	124.1	86.9	1785.0	17.1	116.8	98.1	1736.0	14.3

MODEL: YCWS0140SC

IPLV= 19.3

LCWT (°F)	LEAVING CONDENSER WATER TEMPERATURE (°F)											
	85.0				95.0				105.0			
	TONS	KW	MBH	EER	TONS	KW	MBH	EER	TONS	KW	MBH	EER
40.0	127.9	88.1	1835.0	17.4	120.5	99.9	1787.0	14.5	113.0	112.9	1741.0	12.0
42.0	133.0	88.3	1898.0	18.1	125.5	100.2	1848.0	15.0	117.8	113.1	1799.0	12.5
44.0	138.3	88.5	1962.0	18.8	130.6	100.5	1910.0	15.6	122.7	113.4	1859.0	13.0
45.0	141.1	88.6	1995.0	19.1	133.2	100.7	1942.0	15.9	125.2	113.6	1890.0	13.2
46.0	143.8	88.6	2028.0	19.5	135.9	100.8	1975.0	16.2	127.8	113.7	1922.0	13.5
48.0	149.4	88.6	2095.0	20.2	141.3	101.1	2040.0	16.8	133.0	114.1	1985.0	14.0
50.0	155.0	88.5	2162.0	21.0	146.7	101.3	2106.0	17.4	138.2	114.4	2049.0	14.5

MODEL: YCWS0180SC

IPLV= 20.8

LCWT (°F)	LEAVING CONDENSER WATER TEMPERATURE (°F)											
	85.0				95.0				105.0			
	TONS	KW	MBH	EER	TONS	KW	MBH	EER	TONS	KW	MBH	EER
40.0	156.8	97.9	2215.0	19.2	147.8	111.5	2154.0	15.9	138.6	126.2	2094.0	13.2
42.0	163.2	98.0	2293.0	20.0	154.0	111.8	2229.0	16.5	144.5	126.5	2165.0	13.7
44.0	169.7	97.9	2371.0	20.8	160.4	112.0	2306.0	17.2	150.7	126.8	2240.0	14.3
45.0	173.1	97.9	2410.0	21.2	163.7	112.2	2347.0	17.5	153.8	126.9	2278.0	14.5
46.0	176.4	97.8	2450.0	21.6	166.9	112.2	2386.0	17.8	157.0	127.1	2317.0	14.8
48.0	183.6	97.5	2536.0	22.6	173.6	112.4	2467.0	18.5	163.4	127.4	2396.0	15.4
50.0	190.7	97.2	2620.0	23.6	180.5	112.5	2550.0	19.3	170.1	127.7	2476.0	16.0

NOTES:

1. Tons = Unit Cooling Capacity Output
2. KW = Compressor Input Power
3. MBH = Condenser Heat Rejection
4. EER = Chiller Energy Efficiency Ratio
5. LCWT= Leaving Chilled Water Temperature
6. Ratings based on 2.4 GPM cooler water per ton.

MODEL: YCWS0200SC**IPLV= 21.8**

LCWT (°F)	LEAVING CONDENSER WATER TEMPERATURE (°F)											
	85.0				95.0				105.0			
	TONS	KW	MBH	EER	TONS	KW	MBH	EER	TONS	KW	MBH	EER
40.0	179.0	110.1	2524.0	19.5	169.0	125.4	2456.0	16.2	158.5	142.0	2386.0	13.4
42.0	186.2	110.2	2610.0	20.3	176.1	125.7	2542.0	16.8	165.3	142.3	2469.0	13.9
44.0	194.1	110.1	2705.0	21.2	183.0	126.0	2626.0	17.4	172.1	142.6	2551.0	14.5
45.0	198.0	110.1	2751.0	21.6	186.7	126.1	2671.0	17.8	175.4	142.8	2592.0	14.7
46.0	201.9	110.0	2797.0	22.0	190.4	126.2	2716.0	18.1	179.5	143.0	2641.0	15.1
48.0	209.8	109.7	2892.0	22.9	198.5	126.4	2813.0	18.8	186.8	143.3	2731.0	15.6
50.0	217.9	109.4	2988.0	23.9	206.3	126.5	2907.0	19.6	194.1	143.7	2819.0	16.2

MODEL: YCWS0220SC**IPLV= 20.8**

LCWT (°F)	LEAVING CONDENSER WATER TEMPERATURE (°F)											
	85.0				95.0				105.0			
	TONS	KW	MBH	EER	TONS	KW	MBH	EER	TONS	KW	MBH	EER
40.0	195.3	121.3	2758.0	19.3	184.0	138.1	2679.0	16.0	172.6	156.2	2605.0	13.3
42.0	203.3	121.4	2854.0	20.1	191.9	138.5	2775.0	16.6	179.9	156.6	2693.0	13.8
44.0	211.6	121.4	2953.0	20.9	199.8	138.8	2871.0	17.3	187.4	157.0	2784.0	14.3
45.0	215.6	121.4	3001.0	21.3	203.8	138.9	2920.0	17.6	191.4	157.2	2833.0	14.6
46.0	219.7	121.3	3051.0	21.7	208.0	139.1	2970.0	17.9	195.5	157.4	2884.0	14.9
48.0	228.7	121.1	3157.0	22.7	216.2	139.3	3070.0	18.6	203.4	157.8	2980.0	15.5
50.0	237.6	120.7	3263.0	23.6	224.6	139.4	3171.0	19.3	211.8	158.3	3082.0	16.1

MODEL: YCWS0240SC**IPLV= 21.2**

LCWT (°F)	LEAVING CONDENSER WATER TEMPERATURE (°F)											
	85.0				95.0				105.0			
	TONS	KW	MBH	EER	TONS	KW	MBH	EER	TONS	KW	MBH	EER
40.0	210.9	132.8	2983.0	19.1	198.3	151.0	2895.0	15.8	186.3	170.8	2818.0	13.1
42.0	219.5	132.9	3087.0	19.8	206.3	151.4	2992.0	16.4	194.1	171.2	2913.0	13.6
44.0	228.3	133.0	3193.0	20.6	215.6	151.8	3105.0	17.0	202.3	171.6	3014.0	14.1
45.0	232.8	132.9	3248.0	21.0	219.9	152.0	3158.0	17.4	206.4	171.9	3064.0	14.4
46.0	237.4	132.9	3303.0	21.4	224.4	152.2	3212.0	17.7	211.0	172.1	3119.0	14.7
48.0	246.8	132.7	3414.0	22.3	233.4	152.4	3320.0	18.4	219.6	172.6	3224.0	15.3
50.0	256.3	132.4	3528.0	23.2	242.6	152.6	3432.0	19.1	228.5	173.1	3333.0	15.8

NOTES:

1. **Tons** = Unit Cooling Capacity Output
2. **KW** = Compressor Input Power
3. **MBH** = Condenser Heat Rejection
4. **EER** = Chiller Energy Efficiency Ratio
5. **LCWT**= Leaving Chilled Water Temperature
6. Ratings based on 2.4 GPM cooler water per ton.

Ratings SI (R-22)

MODEL: YCWS0100SC

LCWT (°C)	LEAVING CONDENSER WATER TEMPERATURE (°C)											
	25.0				30.0				35.0			
	KW	KW	KW	COP	KW	KW	KW	COP	KW	KW	KW	COP
5.0	333.2	56.8	390.0	5.9	316.7	64.1	380.0	4.9	299.7	71.6	371.0	4.2
6.0	345.3	56.7	402.0	6.1	328.4	64.3	392.0	5.1	311.0	71.9	382.0	4.3
7.0	357.7	56.6	414.0	6.3	340.3	64.4	404.0	5.3	322.6	72.1	394.0	4.5
8.0	370.4	56.4	426.0	6.6	352.6	64.5	417.0	5.5	334.5	72.3	406.0	4.6
9.0	383.4	56.1	439.0	6.8	365.2	64.5	429.0	5.7	346.7	72.5	419.0	4.8
10.0	396.7	55.7	452.0	7.1	378.1	64.4	442.0	5.9	359.2	72.7	431.0	4.9

MODEL: YCWS0120SC

LCWT (°C)	LEAVING CONDENSER WATER TEMPERATURE (°C)											
	25.0				30.0				35.0			
	KW	KW	KW	COP	KW	KW	KW	COP	KW	KW	KW	COP
5.0	402.0	67.9	469.0	5.9	382.4	76.7	459.0	5.0	362.3	85.7	448.0	4.2
6.0	416.4	67.9	484.0	6.1	396.3	76.9	473.0	5.2	375.8	86.0	461.0	4.4
7.0	431.2	67.7	499.0	6.4	410.7	77.0	487.0	5.3	389.7	86.3	476.0	4.5
8.0	446.3	67.5	513.0	6.6	425.4	77.1	502.0	5.5	403.8	86.5	490.0	4.7
9.0	461.8	67.2	529.0	6.9	440.3	77.1	517.0	5.7	418.4	86.7	505.0	4.8
10.0	477.4	66.8	544.0	7.2	455.6	77.1	532.0	5.9	433.1	86.9	520.0	5.0

MODEL: YCWS0140SC

LCWT (°C)	LEAVING CONDENSER WATER TEMPERATURE (°C)											
	25.0				30.0				35.0			
	KW	KW	KW	COP	KW	KW	KW	COP	KW	KW	KW	COP
5.0	475.8	79.1	554.0	6.0	452.8	89.4	542.0	5.1	429.3	100.0	529.0	4.3
6.0	492.8	79.1	571.0	6.2	469.3	89.6	558.0	5.2	445.2	100.3	545.0	4.4
7.0	510.2	78.9	589.0	6.5	486.2	89.7	576.0	5.4	461.5	100.6	562.0	4.6
8.0	527.5	78.7	606.0	6.7	503.4	89.8	593.0	5.6	478.3	100.9	579.0	4.7
9.0	545.9	78.4	624.0	7.0	521.0	89.9	610.0	5.8	495.4	101.1	596.0	4.9
10.0	564.8	78.1	642.0	7.2	539.1	89.9	629.0	6.0	512.8	101.3	614.0	5.1

MODEL: YCWS0180SC

LCWT (°C)	LEAVING CONDENSER WATER TEMPERATURE (°C)											
	25.0				30.0				35.0			
	KW	KW	KW	COP	KW	KW	KW	COP	KW	KW	KW	COP
5.0	582.3	87.2	669.0	6.7	554.4	99.4	653.0	5.6	525.5	111.7	637.0	4.7
6.0	603.6	86.9	690.0	7.0	574.8	99.4	674.0	5.8	544.3	111.9	656.0	4.9
7.0	625.2	86.5	711.0	7.2	595.6	99.4	695.0	6.0	565.7	112.1	677.0	5.0
8.0	646.9	86.0	732.0	7.5	617.3	99.3	716.0	6.2	586.5	112.3	698.0	5.2
9.0	670.1	85.4	755.0	7.9	639.3	99.1	738.0	6.5	607.7	112.5	720.0	5.4
10.0	694.3	84.6	778.0	8.2	661.6	98.9	760.0	6.7	629.5	112.5	742.0	5.6

NOTES:

1. **KW_o** = Unit kW Cooling Capacity Output
2. **KW_i** = Compressor kW Input
3. **KW** = Condenser Heat Rejection
4. **COP** = Coefficient of Performance
5. **LCWT** = Leaving Chilled Water Temperature
6. Ratings based on 0.047 l/s cooler water per kW.

MODEL: YCWS0200SC

LCWT (°C)	LEAVING CONDENSER WATER TEMPERATURE (°C)											
	25.0				30.0				35.0			
	KW	KW	KW	COP	KW	KW	KW	COP	KW	KW	KW	COP
5.0	666.2	98.0	764.0	6.8	632.8	111.7	744.0	5.7	601.0	125.6	726.0	4.8
6.0	690.4	97.7	788.0	7.1	657.4	111.8	769.0	5.9	623.6	125.9	749.0	5.0
7.0	714.9	97.3	812.0	7.4	681.4	111.8	793.0	6.1	646.9	126.1	773.0	5.1
8.0	740.2	96.8	837.0	7.7	705.9	111.7	817.0	6.3	670.6	126.3	797.0	5.3
9.0	766.1	96.2	862.0	8.0	731.0	111.5	842.0	6.6	692.6	126.4	819.0	5.5
10.0	792.5	95.4	887.0	8.3	756.6	111.3	867.0	6.8	719.9	126.5	846.0	5.7

MODEL: YCWS0220SC

LCWT (°C)	LEAVING CONDENSER WATER TEMPERATURE (°C)											
	25.0				30.0				35.0			
	KW	KW	KW	COP	KW	KW	KW	COP	KW	KW	KW	COP
5.0	726.0	108.1	834.0	6.7	690.9	123.1	814.0	5.6	654.5	138.3	792.0	4.7
6.0	752.3	107.8	860.0	7.0	716.3	123.2	839.0	5.8	678.8	138.6	817.0	4.9
7.0	779.2	107.5	886.0	7.3	742.4	123.3	865.0	6.0	704.9	138.9	843.0	5.1
8.0	806.7	106.9	913.0	7.5	769.2	123.2	892.0	6.2	730.7	139.2	869.0	5.3
9.0	835.0	106.3	941.0	7.9	796.5	123.1	919.0	6.5	757.1	139.4	896.0	5.4
10.0	863.9	105.5	969.0	8.2	824.6	122.8	947.0	6.7	784.3	139.5	923.0	5.6

MODEL: YCWS0240SC

LCWT (°C)	LEAVING CONDENSER WATER TEMPERATURE (°C)											
	25.0				30.0				35.0			
	KW	KW	KW	COP	KW	KW	KW	COP	KW	KW	KW	COP
5.0	784.0	118.4	902.0	6.6	746.0	134.7	880.0	5.5	706.9	151.2	858.0	4.7
6.0	810.6	118.2	928.0	6.9	773.6	134.9	908.0	5.7	733.6	151.6	885.0	4.8
7.0	841.2	117.8	959.0	7.1	801.7	134.9	936.0	5.9	761.0	152.0	913.0	5.0
8.0	872.2	117.3	989.0	7.4	830.4	134.9	965.0	6.2	788.9	152.3	941.0	5.2
9.0	907.0	116.5	1023.0	7.8	859.9	134.8	994.0	6.4	817.4	152.5	970.0	5.4
10.0	931.6	115.8	1047.0	8.0	889.8	134.6	1024.0	6.6	846.5	152.7	999.0	5.5

NOTES:

1. **KW_o** = Unit kW Cooling Capacity Output
2. **KW_i** = Compressor kW Input
3. **KW** = Condenser Heat Rejection
4. **COP** = Coefficient of Performance
5. **LCWT** = Leaving Chilled Water Temperature
6. Ratings based on 0.047 l/s cooler water per kW.

Ratings- Brine (30 % Ethylene Glycol) English (R-22)

MODEL: YCWS0100SC

LCWT (°F)	LEAVING CONDENSER WATER TEMPERATURE (°F)											
	85.0				95.0				105.0			
	TONS	KW	MBH	EER	TONS	KW	MBH	EER	TONS	KW	MBH	EER
16.0	45.6	61.6	757.0	8.9	42.2	72.0	751.0	7.0	38.6	85.7	755.0	5.4
20.0	50.9	60.9	818.0	10.0	47.2	70.5	807.0	8.0	43.4	82.8	803.0	6.3
24.0	56.9	61.2	891.0	11.2	53.0	70.1	875.0	9.1	49.0	81.4	865.0	7.2
28.0	63.9	61.6	977.0	12.5	59.7	70.1	955.0	10.2	55.4	80.5	939.0	8.3
32.0	72.3	62.1	1080.0	14.0	67.8	70.3	1053.0	11.6	63.1	80.2	1030.0	9.4
36.0	81.7	62.8	1194.0	15.6	76.7	71.0	1162.0	13.0	71.6	80.4	1133.0	10.7
40.0	88.7	63.2	1280.0	16.8	83.5	71.5	1245.0	14.0	78.1	80.6	1212.0	11.6

MODEL: YCWS0120SC

LCWT (°F)	LEAVING CONDENSER WATER TEMPERATURE (°F)											
	85.0				95.0				105.0			
	TONS	KW	MBH	EER	TONS	KW	MBH	EER	TONS	KW	MBH	EER
16.0	55.4	73.7	916.0	9.0	51.3	86.0	909.0	7.2	47.2	101.8	913.0	5.6
20.0	61.7	72.9	989.0	10.1	57.4	84.3	976.0	8.2	52.9	98.7	972.0	6.4
24.0	68.9	73.2	1076.0	11.3	64.3	83.9	1057.0	9.2	59.6	97.2	1046.0	7.4
28.0	77.3	73.7	1179.0	12.6	72.4	83.9	1154.0	10.3	67.3	96.4	1136.0	8.4
32.0	87.4	74.3	1302.0	14.1	82.0	84.2	1271.0	11.7	76.4	96.0	1245.0	9.6
36.0	98.5	75.1	1438.0	15.7	92.7	85.0	1402.0	13.1	86.6	96.3	1368.0	10.8
40.0	106.9	75.6	1540.0	17.0	100.7	85.5	1500.0	14.1	94.4	96.6	1462.0	11.7

MODEL: YCWS0140SC

LCWT (°F)	LEAVING CONDENSER WATER TEMPERATURE (°F)											
	85.0				95.0				105.0			
	TONS	KW	MBH	EER	TONS	KW	MBH	EER	TONS	KW	MBH	EER
16.0	65.8	86.0	1083.0	9.2	61.0	100.4	1075.0	7.3	56.2	118.5	1078.0	5.7
20.0	73.2	85.2	1169.0	10.3	68.2	98.4	1154.0	8.3	63.0	115.0	1148.0	6.6
24.0	81.7	85.4	1272.0	11.5	76.3	98.0	1250.0	9.4	70.8	113.4	1236.0	7.5
28.0	91.7	85.9	1393.0	12.8	85.8	98.0	1364.0	10.5	79.9	112.5	1342.0	8.5
32.0	103.5	86.6	1537.0	14.3	97.2	98.3	1501.0	11.9	90.7	112.2	1471.0	9.7
36.0	116.5	87.5	1697.0	16.0	109.7	99.1	1654.0	13.3	102.7	112.5	1616.0	11.0
40.0	126.5	88.1	1818.0	17.2	119.2	99.8	1770.0	14.3	111.8	112.8	1726.0	11.9

MODEL: YCWS0180SC

LCWT (°F)	LEAVING CONDENSER WATER TEMPERATURE (°F)											
	85.0				95.0				105.0			
	TONS	KW	MBH	EER	TONS	KW	MBH	EER	TONS	KW	MBH	EER
16.0	80.0	96.1	1288.0	10.0	74.9	111.4	1279.0	8.1	68.8	130.6	1271.0	6.3
20.0	89.9	95.3	1403.0	11.3	83.2	109.7	1373.0	9.1	76.9	127.4	1357.0	7.2
24.0	98.8	95.6	1511.0	12.4	93.4	109.4	1494.0	10.2	88.2	125.9	1488.0	8.4
28.0	112.7	96.2	1680.0	14.1	104.9	109.6	1632.0	11.5	97.3	125.4	1595.0	9.3
32.0	127.4	96.8	1859.0	15.8	119.7	110.0	1811.0	13.0	110.0	125.2	1747.0	10.5
36.0	143.8	97.6	2059.0	17.7	135.4	110.9	2003.0	14.6	126.7	125.7	1949.0	12.1
40.0	156.0	97.9	2206.0	19.1	146.8	111.5	2142.0	15.8	138.0	126.2	2087.0	13.1

NOTES:

1. **TONS** = Unit Cooling Capacity Output
2. **KW** = Compressor Input Power
3. **MBH** = Condenser Heat Rejection
4. **EER** = Chiller Energy Efficiency Ratio
5. **LCWT** = Leaving Chilled Water Temperature
6. Ratings based on 2.4 GPM cooler water per ton.

MODEL: YCWS0200SC

LCWT (°F)	LEAVING CONDENSER WATER TEMPERATURE (°F)											
	85.0				95.0				105.0			
	TONS	KW	MBH	EER	TONS	KW	MBH	EER	TONS	KW	MBH	EER
16.0	92.3	108.0	1476.0	10.2	85.8	125.0	1456.0	8.2	78.7	146.1	1443.0	6.5
20.0	102.8	107.2	1599.0	11.5	94.5	123.3	1555.0	9.2	87.6	142.8	1538.0	7.4
24.0	114.8	107.6	1744.0	12.8	107.3	123.0	1707.0	10.5	99.6	141.4	1678.0	8.5
28.0	128.8	108.2	1915.0	14.3	120.7	123.3	1869.0	11.8	112.4	140.8	1830.0	9.6
32.0	145.7	108.9	2119.0	16.1	136.8	123.8	2064.0	13.3	127.7	140.8	2013.0	10.9
36.0	164.3	109.7	2346.0	18.0	154.7	124.8	2282.0	14.9	144.8	141.4	2220.0	12.3
40.0	178.3	110.1	2515.0	19.4	168.1	125.4	2445.0	16.1	157.8	141.9	2378.0	13.3

MODEL: YCWS0220SC

LCWT (°F)	LEAVING CONDENSER WATER TEMPERATURE (°F)											
	85.0				95.0				105.0			
	TONS	KW	MBH	EER	TONS	KW	MBH	EER	TONS	KW	MBH	EER
16.0	100.3	118.7	1609.0	10.1	93.1	137.4	1586.0	8.1	85.3	160.6	1572.0	6.4
20.0	110.4	117.7	1726.0	11.3	103.2	135.4	1701.0	9.1	95.1	157.0	1677.0	7.3
24.0	125.2	118.3	1905.0	12.7	116.8	135.2	1862.0	10.4	108.3	155.4	1830.0	8.4
28.0	140.4	119.0	2091.0	14.2	131.5	135.5	2041.0	11.6	122.4	154.8	1997.0	9.5
32.0	158.6	119.8	2312.0	15.9	145.8	136.0	2213.0	12.9	139.1	154.8	2197.0	10.8
36.0	179.0	120.8	2561.0	17.8	168.5	137.3	2491.0	14.7	157.8	155.6	2424.0	12.2
40.0	194.2	121.3	2744.0	19.2	183.2	138.1	2670.0	15.9	171.8	156.2	2595.0	13.2

MODEL: YCWS0240SC

LCWT (°F)	LEAVING CONDENSER WATER TEMPERATURE (°F)											
	85.0				95.0				105.0			
	TONS	KW	MBH	EER	TONS	KW	MBH	EER	TONS	KW	MBH	EER
16.0	108.6	129.7	1745.0	10.0	98.3	150.6	1693.0	7.8	90.0	176.4	1682.0	6.1
20.0	120.8	128.7	1889.0	11.3	112.2	148.0	1852.0	9.1	103.5	171.5	1827.0	7.2
24.0	134.9	129.3	2060.0	12.5	126.0	147.8	2016.0	10.2	116.8	169.9	1982.0	8.3
28.0	151.5	130.1	2262.0	14.0	141.8	148.1	2207.0	11.5	132.0	169.2	2161.0	9.4
32.0	171.3	131.0	2502.0	15.7	160.8	148.8	2437.0	13.0	146.2	169.2	2332.0	10.4
36.0	192.7	132.2	2764.0	17.5	181.7	150.1	2692.0	14.5	170.1	170.0	2621.0	12.0
40.0	209.1	132.7	2963.0	18.9	197.1	150.9	2880.0	15.7	185.3	170.7	2806.0	13.0

NOTES:

1. **Tons** = Unit Cooling Capacity Output
2. **KW** = Compressor Input Power
3. **MBH** = Condenser Heat Rejection
4. **EER** = Chiller Energy Efficiency Ratio
5. **LCWT** = Leaving Chilled Water Temperature
6. Ratings based on 2.4 GPM cooler water per ton.

Ratings- Brine (30 % Ethylene Glycol) SI (R-22)

MODEL: YCWS0100SC

LCWT (°C)	LEAVING CONDENSER WATER TEMPERATURE (°C)															
	25.0				30.0				35.0				40.0			
	KW	KW	KW	COP	KW	KW	KW	COP	KW	KW	KW	COP	KW	KW	KW	COP
-8.0	177.2	54.6	231.0	3.3	166.2	61.9	228.0	2.7	155.1	71.1	226.0	2.2	141.7	82.9	224.0	1.7
-6.0	195.2	54.9	250.0	3.6	183.7	61.8	245.0	3.0	171.7	70.3	242.0	2.4	159.7	80.9	240.0	2.0
-4.0	215.6	55.3	270.0	3.9	203.3	62.0	265.0	3.3	190.7	70.1	260.0	2.7	177.9	79.9	257.0	2.2
-2.0	239.2	55.8	294.0	4.3	226.1	62.4	288.0	3.6	212.7	70.1	282.0	3.0	198.8	79.3	278.0	2.5
0.0	267.0	56.2	323.0	4.8	252.8	62.9	315.0	4.0	238.3	70.3	308.0	3.4	223.4	79.1	302.0	2.8
2.0	298.5	56.7	355.0	5.3	283.1	63.5	346.0	4.5	267.4	70.9	338.0	3.8	251.3	79.3	330.0	3.2
4.0	321.1	56.8	378.0	5.7	305.1	64.0	369.0	4.8	288.7	71.4	360.0	4.0	271.8	79.6	351.0	3.4

MODEL: YCWS0120SC

LCWT (°C)	LEAVING CONDENSER WATER TEMPERATURE (°C)															
	25.0				30.0				35.0				40.0			
	KW	KW	KW	COP	KW	KW	KW	COP	KW	KW	KW	COP	KW	KW	KW	COP
-8.0	214.8	65.3	280.0	3.3	201.9	74.1	276.0	2.7	188.6	84.9	273.0	2.2	175.1	98.4	273.0	1.8
-6.0	236.3	65.6	301.0	3.6	222.6	74.0	296.0	3.0	208.7	84.1	292.0	2.5	194.4	96.6	291.0	2.0
-4.0	260.7	66.1	326.0	3.9	246.2	74.3	320.0	3.3	231.4	83.9	315.0	2.8	216.2	95.5	311.0	2.3
-2.0	289.0	66.6	355.0	4.3	273.6	74.7	348.0	3.7	257.5	83.9	341.0	3.1	241.3	95.0	336.0	2.5
0.0	322.1	67.1	389.0	4.8	305.4	75.2	380.0	4.1	288.3	84.2	372.0	3.4	270.7	94.7	365.0	2.9
2.0	359.5	67.7	427.0	5.3	341.4	76.0	417.0	4.5	323.1	84.9	408.0	3.8	304.1	95.1	399.0	3.2
4.0	386.7	67.9	454.0	5.7	367.7	76.5	444.0	4.8	348.2	85.4	433.0	4.1	328.6	95.3	424.0	3.5

MODEL: YCWS0140SC

LCWT (°C)	LEAVING CONDENSER WATER TEMPERATURE (°C)															
	25.0				30.0				35.0				40.0			
	KW	KW	KW	COP	KW	KW	KW	COP	KW	KW	KW	COP	KW	KW	KW	COP
-8.0	254.9	76.2	331.0	3.4	239.8	86.5	326.0	2.8	224.3	99.1	323.0	2.3	208.7	114.6	323.0	1.8
-6.0	280.3	76.5	356.0	3.7	264.2	86.4	350.0	3.1	247.9	98.2	346.0	2.5	231.2	112.7	343.0	2.1
-4.0	309.0	77.0	386.0	4.0	292.1	86.7	378.0	3.4	274.7	97.9	372.0	2.8	256.9	111.5	368.0	2.3
-2.0	342.2	77.6	419.0	4.4	324.1	87.1	411.0	3.7	305.5	98.0	403.0	3.1	286.5	110.9	397.0	2.6
0.0	381.2	78.1	459.0	4.9	361.8	87.7	449.0	4.1	341.7	98.3	440.0	3.5	321.2	110.7	431.0	2.9
2.0	425.3	78.8	504.0	5.4	404.1	88.6	492.0	4.6	382.5	99.1	481.0	3.9	360.5	111.1	471.0	3.3
4.0	457.4	79.1	536.0	5.8	435.1	89.1	524.0	4.9	412.3	99.6	511.0	4.1	389.1	111.3	500.0	3.5

MODEL: YCWS0180SC

LCWT (°C)	LEAVING CONDENSER WATER TEMPERATURE (°C)															
	25.0				30.0				35.0				40.0			
	KW	KW	KW	COP	KW	KW	KW	COP	KW	KW	KW	COP	KW	KW	KW	COP
-8.0	308.3	85.3	393.0	3.6	293.8	96.7	390.0	3.0	274.6	110.2	384.0	2.5	255.6	126.6	382.0	2.0
-6.0	339.7	85.6	425.0	4.0	323.8	96.7	420.0	3.4	302.2	109.6	411.0	2.8	283.7	124.9	408.0	2.3
-4.0	376.4	86.1	462.0	4.4	356.1	97.0	453.0	3.7	335.0	109.4	444.0	3.1	315.6	124.0	439.0	2.5
-2.0	420.7	86.7	507.0	4.9	398.5	97.5	496.0	4.1	375.6	109.6	485.0	3.4	347.8	123.7	471.0	2.8
0.0	469.5	87.0	556.0	5.4	445.5	98.1	543.0	4.5	420.6	110.0	530.0	3.8	389.2	123.6	512.0	3.2
2.0	524.7	87.4	612.0	6.0	498.7	98.9	597.0	5.0	472.0	110.9	582.0	4.3	444.7	124.1	568.0	3.6
4.0	564.3	87.3	651.0	6.5	537.1	99.2	636.0	5.4	508.6	111.4	620.0	4.6	480.5	124.5	605.0	3.9

NOTES:

1. **KW_o** = Unit kW Cooling Capacity Output
2. **KW_i** = Compressor kW Input
3. **KW** = Condenser Heat Rejection
4. **COP** = Coefficient of Performance
5. **LCWT** = Leaving Chilled Water Temperature
6. Ratings based on 0.047 l/s cooler water per kW.

MODEL: YCWS0200SC

LCWT (°C)	LEAVING CONDENSER WATER TEMPERATURE (°C)															
	25.0				30.0				35.0				40.0			
	KW	KW	KW	COP	KW	KW	KW	COP	KW	KW	KW	COP	KW	KW	KW	COP
-8.0	357.5	96.0	453.0	3.7	336.2	108.7	445.0	3.1	311.0	123.8	434.0	2.5	289.7	141.9	431.0	2.0
-6.0	393.2	96.3	489.0	4.1	371.1	108.7	479.0	3.4	348.0	123.1	471.0	2.8	324.9	140.1	465.0	2.3
-4.0	433.7	96.9	530.0	4.5	410.2	109.1	519.0	3.8	386.2	123.0	509.0	3.1	361.1	139.3	500.0	2.6
-2.0	481.0	97.4	578.0	4.9	455.6	109.7	565.0	4.2	429.6	123.3	553.0	3.5	403.1	138.9	542.0	2.9
0.0	536.5	97.8	634.0	5.5	509.1	110.3	619.0	4.6	481.0	123.8	604.0	3.9	452.3	138.9	591.0	3.3
2.0	599.4	98.3	697.0	6.1	569.6	111.1	680.0	5.1	539.1	124.7	663.0	4.3	508.2	139.6	647.0	3.6
4.0	644.4	98.1	742.0	6.6	612.8	111.5	724.0	5.5	581.6	125.3	706.0	4.6	549.0	140.1	689.0	3.9

MODEL: YCWS0220SC

LCWT (°C)	LEAVING CONDENSER WATER TEMPERATURE (°C)															
	25.0				30.0				35.0				40.0			
	KW	KW	KW	COP	KW	KW	KW	COP	KW	KW	KW	COP	KW	KW	KW	COP
-8.0	388.4	105.5	493.0	3.7	366.2	119.5	485.0	3.1	0.0	0.0	468.0	0.0	318.2	155.8	474.0	2.0
-6.0	427.0	105.9	533.0	4.0	404.0	119.5	523.0	3.4	378.8	135.2	514.0	2.8	353.0	154.0	507.0	2.3
-4.0	472.9	106.6	579.0	4.4	446.9	120.0	566.0	3.7	421.1	135.2	556.0	3.1	393.0	153.1	546.0	2.6
-2.0	524.3	107.2	631.0	4.9	496.6	120.7	617.0	4.1	468.0	135.6	603.0	3.5	438.8	152.7	591.0	2.9
0.0	584.6	107.7	692.0	5.4	554.4	121.4	675.0	4.6	513.0	136.0	649.0	3.8	492.7	152.8	645.0	3.2
2.0	653.3	108.3	761.0	6.0	620.9	122.4	743.0	5.1	587.5	137.2	724.0	4.3	553.6	153.6	707.0	3.6
4.0	701.6	108.2	809.0	6.5	668.4	122.9	791.0	5.4	633.7	137.9	771.0	4.6	598.1	154.1	752.0	3.9

MODEL: YCWS0240SC

LCWT (°C)	LEAVING CONDENSER WATER TEMPERATURE (°C)															
	25.0				30.0				35.0				40.0			
	KW	KW	KW	COP	KW	KW	KW	COP	KW	KW	KW	COP	KW	KW	KW	COP
-8.0	420.3	115.3	535.0	3.6	395.3	130.6	525.0	3.0	363.9	148.8	512.0	2.5	329.5	171.4	501.0	1.9
-6.0	462.5	115.8	578.0	4.0	436.1	130.6	566.0	3.3	408.9	147.8	556.0	2.8	381.1	168.4	549.0	2.3
-4.0	510.4	116.5	626.0	4.4	482.0	131.1	613.0	3.7	453.6	147.8	601.0	3.1	424.1	167.3	591.0	2.5
-2.0	565.8	117.2	683.0	4.8	535.8	131.9	667.0	4.1	504.9	148.1	653.0	3.4	473.4	166.9	640.0	2.8
0.0	631.0	117.8	748.0	5.4	598.6	132.7	731.0	4.5	565.4	148.8	714.0	3.8	531.4	167.0	698.0	3.2
2.0	703.2	118.5	821.0	5.9	668.8	133.8	802.0	5.0	633.4	150.0	783.0	4.2	597.0	167.9	764.0	3.6
4.0	756.3	118.5	874.0	6.4	719.2	134.4	853.0	5.4	681.9	150.8	832.0	4.5	644.5	168.5	813.0	3.8

NOTES:

1. **KW_o** = Unit kW Cooling Capacity Output
2. **KW_i** = Compressor kW Input
3. **KW** = Condenser Heat Rejection
4. **COP** = Coefficient of Performance
5. **LCWT** = Leaving Chilled Water Temperature
6. Ratings based on 0.047 l/s cooler water per kW.

Ratings- Brine (30 % Propylene Glycol) English (R-22)

MODEL: YCWS0100SC

LCWT (°F)	LEAVING CONDENSER WATER TEMPERATURE (°F)											
	85.0				95.0				105.0			
	TONS	KW	MBH	EER	TONS	KW	MBH	EER	TONS	KW	MBH	EER
16.0	45.4	61.6	755.0	8.9	42.0	72.1	750.0	7.0	38.5	85.7	754.0	5.4
20.0	50.7	60.9	816.0	10.0	47.0	70.5	805.0	8.0	43.3	82.8	802.0	6.3
24.0	56.7	61.2	888.0	11.1	52.8	70.1	872.0	9.0	48.8	81.4	863.0	7.2
28.0	63.7	61.6	974.0	12.4	59.5	70.1	952.0	10.2	55.2	80.6	937.0	8.2
32.0	72.0	62.1	1076.0	13.9	67.5	70.3	1049.0	11.5	62.8	80.2	1027.0	9.4
36.0	81.3	62.8	1190.0	15.5	76.4	70.9	1158.0	12.9	71.3	80.4	1129.0	10.6
40.0	88.3	63.2	1276.0	16.8	83.1	71.4	1241.0	14.0	77.8	80.6	1208.0	11.6

MODEL: YCWS0120SC

LCWT (°F)	LEAVING CONDENSER WATER TEMPERATURE (°F)											
	85.0				95.0				105.0			
	TONS	KW	MBH	EER	TONS	KW	MBH	EER	TONS	KW	MBH	EER
16.0	55.1	73.7	912.0	9.0	51.0	86.1	906.0	7.1	46.9	101.9	910.0	5.5
20.0	61.3	72.9	985.0	10.1	57.0	84.3	972.0	8.1	52.7	98.8	969.0	6.4
24.0	68.5	73.2	1072.0	11.2	63.9	83.9	1053.0	9.1	59.2	97.3	1042.0	7.3
28.0	76.9	73.7	1174.0	12.5	72.0	83.9	1149.0	10.3	66.9	96.4	1132.0	8.3
32.0	86.9	74.3	1296.0	14.0	81.5	84.2	1265.0	11.6	76.0	96.0	1240.0	9.5
36.0	98.0	75.1	1432.0	15.7	92.2	84.9	1396.0	13.0	86.2	96.3	1362.0	10.7
40.0	106.4	75.6	1534.0	16.9	100.2	85.5	1494.0	14.1	93.9	96.6	1456.0	11.7

MODEL: YCWS0140SC

LCWT (°F)	LEAVING CONDENSER WATER TEMPERATURE (°F)											
	85.0				95.0				105.0			
	TONS	KW	MBH	EER	TONS	KW	MBH	EER	TONS	KW	MBH	EER
16.0	65.5	86.0	1079.0	9.1	60.7	100.4	1071.0	7.3	55.9	118.6	1075.0	5.7
20.0	72.8	85.1	1164.0	10.3	67.8	98.4	1149.0	8.3	62.7	115.1	1144.0	6.5
24.0	81.3	85.4	1266.0	11.4	75.9	98.0	1245.0	9.3	70.4	113.5	1232.0	7.4
28.0	91.2	85.9	1387.0	12.7	85.4	98.0	1359.0	10.5	79.5	112.6	1337.0	8.5
32.0	102.9	86.6	1530.0	14.3	96.6	98.3	1495.0	11.8	90.2	112.2	1465.0	9.7
36.0	116.0	87.5	1690.0	15.9	109.2	99.1	1648.0	13.2	102.1	112.5	1609.0	10.9
40.0	125.8	88.0	1810.0	17.2	118.6	99.7	1764.0	14.3	111.2	112.8	1719.0	11.8

MODEL: YCWS0180SC

LCWT (°F)	LEAVING CONDENSER WATER TEMPERATURE (°F)											
	85.0				95.0				105.0			
	TONS	KW	MBH	EER	TONS	KW	MBH	EER	TONS	KW	MBH	EER
16.0	80.5	96.1	1294.0	10.1	74.7	111.5	1276.0	8.0	69.4	130.3	1278.0	6.4
20.0	89.6	95.3	1400.0	11.3	82.5	109.7	1364.0	9.0	77.0	127.3	1358.0	7.3
24.0	100.1	95.7	1528.0	12.6	93.5	109.4	1495.0	10.3	86.6	126.0	1469.0	8.2
28.0	112.4	96.2	1677.0	14.0	105.3	109.6	1637.0	11.5	98.5	125.3	1609.0	9.4
32.0	127.1	96.8	1856.0	15.8	119.4	110.0	1808.0	13.0	111.5	125.2	1764.0	10.7
36.0	143.4	97.6	2054.0	17.6	135.0	110.9	1999.0	14.6	126.4	125.7	1946.0	12.1
40.0	155.7	97.9	2202.0	19.1	146.8	111.5	2142.0	15.8	137.7	126.2	2083.0	13.1

NOTES:

1. **Tons** = Unit Cooling Capacity Output
2. **KW** = Compressor Input Power
3. **MBH** = Condenser Heat Rejection
4. **EER** = Chiller Energy Efficiency Ratio
5. **LCWT** = Leaving Chilled Water Temperature
6. Ratings based on 2.4 GPM cooler water per ton.

MODEL: YCWS0200SC

LEAVING CONDENSER WATER TEMPERATURE (°F)

LCWT (°F)	85.0				95.0				105.0			
	TONS	KW	MBH	EER	TONS	KW	MBH	EER	TONS	KW	MBH	EER
16.0	92.2	108.0	1474.0	10.2	85.5	125.1	1453.0	8.2	78.7	146.0	1443.0	6.5
20.0	102.6	107.2	1597.0	11.5	95.5	123.2	1567.0	9.3	88.3	142.7	1547.0	7.4
24.0	114.5	107.6	1741.0	12.8	107.0	123.0	1704.0	10.4	99.3	141.4	1674.0	8.4
28.0	128.5	108.2	1912.0	14.3	120.5	123.2	1866.0	11.7	112.2	140.8	1826.0	9.6
32.0	145.3	108.8	2115.0	16.0	136.5	123.8	2060.0	13.2	127.5	140.8	2010.0	10.9
36.0	163.9	109.7	2341.0	17.9	154.3	124.7	2277.0	14.8	144.5	141.4	2216.0	12.3
40.0	177.7	110.1	2507.0	19.4	167.7	125.4	2440.0	16.1	157.4	141.9	2373.0	13.3

MODEL: YCWS0220SC

LEAVING CONDENSER WATER TEMPERATURE (°F)

LCWT (°F)	85.0				95.0				105.0			
	TONS	KW	MBH	EER	TONS	KW	MBH	EER	TONS	KW	MBH	EER
16.0	100.4	118.7	1610.0	10.2	93.1	137.4	1586.0	8.1	85.7	160.5	1576.0	6.4
20.0	111.8	117.8	1743.0	11.4	104.1	135.4	1711.0	9.2	96.2	156.8	1689.0	7.4
24.0	124.9	118.3	1903.0	12.7	116.6	135.2	1861.0	10.4	108.4	155.4	1831.0	8.4
28.0	140.1	119.0	2088.0	14.1	131.3	135.5	2038.0	11.6	122.2	154.8	1995.0	9.5
32.0	158.4	119.8	2310.0	15.9	148.8	136.1	2250.0	13.1	138.9	154.8	2195.0	10.8
36.0	178.6	120.8	2555.0	17.7	168.2	137.3	2487.0	14.7	157.4	155.6	2420.0	12.1
40.0	193.8	121.3	2739.0	19.2	182.7	138.0	2663.0	15.9	171.5	156.2	2591.0	13.2

MODEL: YCWS0240SC

LEAVING CONDENSER WATER TEMPERATURE (°F)

LCWT (°F)	85.0				95.0				105.0			
	TONS	KW	MBH	EER	TONS	KW	MBH	EER	TONS	KW	MBH	EER
16.0	108.4	129.7	1743.0	10.0	100.5	150.2	1718.0	8.0	92.3	175.6	1707.0	6.3
20.0	120.6	128.7	1887.0	11.2	112.3	148.0	1852.0	9.1	103.7	171.5	1830.0	7.3
24.0	134.7	129.3	2058.0	12.5	125.8	147.8	2014.0	10.2	116.7	169.9	1980.0	8.2
28.0	151.2	130.1	2258.0	13.9	141.6	148.1	2205.0	11.5	131.8	169.2	2159.0	9.3
32.0	170.9	131.0	2497.0	15.7	160.5	148.8	2433.0	12.9	149.8	169.2	2374.0	10.6
36.0	192.7	132.1	2763.0	17.5	181.3	150.1	2687.0	14.5	169.7	170.0	2617.0	12.0
40.0	209.0	132.7	2961.0	18.9	197.2	150.9	2881.0	15.7	184.9	170.7	2801.0	13.0

NOTES:

1. **Tons** = Unit Cooling Capacity Output
2. **KW** = Compressor Input Power
3. **MBH** = Condenser Heat Rejection
4. **EER** = Chiller Energy Efficiency Ratio
5. **LCWT** = Leaving Chilled Water Temperature
6. Ratings based on 2.4 GPM cooler water per ton.

Ratings- Brine (30 % Propylene Glycol) SI (R-22)

MODEL: YCWS0100SC

LCWT (°C)	LEAVING CONDENSER WATER TEMPERATURE (°C)											
	25.0				30.0				35.0			
	KW	KW	KW	COP	KW	KW	KW	COP	KW	KW	KW	COP
-8.0	165.6	61.9	227.0	2.7	154.5	71.1	225.0	2.2	143.1	82.7	225.0	1.7
-6.0	183.0	61.8	244.0	3.0	171.2	70.3	241.0	2.4	159.1	81.0	240.0	2.0
-4.0	202.5	62.0	264.0	3.3	189.9	70.1	260.0	2.7	177.2	80.0	257.0	2.2
-2.0	225.1	62.4	287.0	3.6	211.7	70.1	281.0	3.0	198.1	79.4	277.0	2.5
0.0	251.7	62.9	314.0	4.0	237.3	70.3	307.0	3.4	222.5	79.1	301.0	2.8
2.0	281.9	63.5	345.0	4.4	266.3	70.9	337.0	3.8	250.3	79.3	329.0	3.2
4.0	303.8	63.9	367.0	4.8	287.5	71.3	358.0	4.0	270.7	79.6	350.0	3.4

MODEL: YCWS0120SC

LCWT (°C)	LEAVING CONDENSER WATER TEMPERATURE (°C)											
	25.0				30.0				35.0			
	KW	KW	KW	COP	KW	KW	KW	COP	KW	KW	KW	COP
-8.0	200.7	74.1	274.0	2.7	187.6	85.0	272.0	2.2	174.2	98.5	272.0	1.8
-6.0	221.4	74.0	295.0	3.0	207.5	84.1	291.0	2.5	193.3	96.7	290.0	2.0
-4.0	244.8	74.2	319.0	3.3	230.1	83.9	314.0	2.7	215.0	95.6	310.0	2.3
-2.0	271.9	74.7	346.0	3.6	256.1	83.9	340.0	3.1	240.0	95.0	335.0	2.5
0.0	303.7	75.2	378.0	4.0	286.7	84.2	370.0	3.4	269.3	94.8	364.0	2.8
2.0	339.8	75.9	415.0	4.5	321.3	84.9	406.0	3.8	302.5	95.1	397.0	3.2
4.0	365.9	76.4	442.0	4.8	346.6	85.4	432.0	4.1	326.9	95.3	422.0	3.4

MODEL: YCWS0140SC

LCWT (°C)	LEAVING CONDENSER WATER TEMPERATURE (°C)											
	25.0				30.0				35.0			
	KW	KW	KW	COP	KW	KW	KW	COP	KW	KW	KW	COP
-8.0	238.5	86.5	325.0	2.8	223.1	99.2	322.0	2.3	207.4	114.7	322.0	1.8
-6.0	262.8	86.4	349.0	3.0	246.6	98.3	344.0	2.5	230.0	112.7	342.0	2.0
-4.0	290.4	86.6	377.0	3.4	273.2	97.9	371.0	2.8	255.6	111.6	367.0	2.3
-2.0	322.4	87.1	409.0	3.7	303.9	98.0	401.0	3.1	285.0	110.9	396.0	2.6
0.0	359.7	87.7	447.0	4.1	340.1	98.3	438.0	3.5	319.6	110.7	430.0	2.9
2.0	402.2	88.5	490.0	4.5	380.6	99.1	479.0	3.8	358.7	111.0	469.0	3.2
4.0	432.9	89.1	522.0	4.9	410.4	99.6	510.0	4.1	387.2	111.3	498.0	3.5

MODEL: YCWS0180SC

LCWT (°C)	LEAVING CONDENSER WATER TEMPERATURE (°C)											
	25.0				30.0				35.0			
	KW	KW	KW	COP	KW	KW	KW	COP	KW	KW	KW	COP
-8.0	293.3	96.7	390.0	3.0	274.7	110.2	384.0	2.5	257.7	126.4	384.0	2.0
-6.0	323.5	96.7	420.0	3.4	303.6	109.5	413.0	2.8	281.1	125.1	406.0	2.3
-4.0	358.0	97.0	455.0	3.7	336.6	109.4	446.0	3.1	314.9	124.0	439.0	2.5
-2.0	397.5	97.5	495.0	4.1	374.8	109.6	484.0	3.4	352.9	123.6	476.0	2.9
0.0	444.4	98.1	542.0	4.5	419.7	110.0	529.0	3.8	394.7	123.6	518.0	3.2
2.0	497.3	98.8	596.0	5.0	470.8	110.8	581.0	4.3	443.7	124.1	567.0	3.6
4.0	535.7	99.2	634.0	5.4	507.8	111.4	619.0	4.6	479.4	124.5	604.0	3.9

NOTES:

1. **KW_o** = Unit kW Cooling Capacity Output
2. **KW_i** = Compressor kW Input
3. **KW** = Condenser Heat Rejection
4. **COP** = Coefficient of Performance
5. **LCWT** = Leaving Chilled Water Temperature
6. Ratings based on 0.047 l/s cooler water per kW.

MODEL: YCWS0200SC

LEAVING CONDENSER WATER TEMPERATURE (°C)

LCWT (°C)	25.0				30.0				35.0			
	KW	KW	KW	COP	KW	KW	KW	COP	KW	KW	KW	COP
-8.0	335.8	108.7	444.0	3.1	314.3	123.7	438.0	2.5	292.3	141.8	434.0	2.1
-6.0	370.2	108.7	479.0	3.4	347.5	123.1	470.0	2.8	324.3	140.1	464.0	2.3
-4.0	409.4	109.1	518.0	3.8	385.2	123.0	508.0	3.1	361.1	139.3	500.0	2.6
-2.0	454.6	109.7	564.0	4.2	428.8	123.3	552.0	3.5	402.3	138.9	541.0	2.9
0.0	507.8	110.3	618.0	4.6	479.9	123.8	603.0	3.9	451.4	138.9	590.0	3.3
2.0	568.3	111.1	679.0	5.1	538.0	124.7	662.0	4.3	507.1	139.6	646.0	3.6
4.0	611.6	111.5	723.0	5.5	580.2	125.3	705.0	4.6	547.8	140.1	688.0	3.9

MODEL: YCWS0220SC

LEAVING CONDENSER WATER TEMPERATURE (°C)

LCWT (°C)	25.0				30.0				35.0			
	KW	KW	KW	COP	KW	KW	KW	COP	KW	KW	KW	COP
-8.0	365.6	119.5	485.0	3.1	342.3	136.0	478.0	2.5	318.3	155.8	474.0	2.0
-6.0	403.5	119.5	523.0	3.4	378.6	135.2	513.0	2.8	353.1	154.0	507.0	2.3
-4.0	446.2	120.0	566.0	3.7	419.8	135.2	555.0	3.1	392.8	153.1	545.0	2.6
-2.0	495.6	120.6	616.0	4.1	467.4	135.6	603.0	3.5	438.1	152.7	590.0	2.9
0.0	553.7	121.3	675.0	4.6	523.2	136.1	659.0	3.8	491.9	152.8	644.0	3.2
2.0	619.5	122.4	741.0	5.1	586.4	137.2	723.0	4.3	552.6	153.6	706.0	3.6
4.0	667.1	122.8	790.0	5.4	632.1	137.9	770.0	4.6	597.0	154.1	751.0	3.9

MODEL: YCWS0240SC

LEAVING CONDENSER WATER TEMPERATURE (°C)

LCWT (°C)	25.0				30.0				35.0			
	KW	KW	KW	COP	KW	KW	KW	COP	KW	KW	KW	COP
-8.0	394.9	130.6	525.0	3.0	369.3	148.6	518.0	2.5	343.1	170.4	513.0	2.0
-6.0	435.4	130.6	566.0	3.3	408.4	147.8	556.0	2.8	380.9	168.4	549.0	2.3
-4.0	481.5	131.1	612.0	3.7	452.8	147.8	600.0	3.1	423.6	167.3	591.0	2.5
-2.0	534.7	131.9	666.0	4.1	504.1	148.1	652.0	3.4	472.7	166.9	639.0	2.8
0.0	597.2	132.7	730.0	4.5	564.2	148.8	713.0	3.8	530.4	167.0	697.0	3.2
2.0	667.0	133.8	800.0	5.0	632.1	150.0	782.0	4.2	595.8	167.8	763.0	3.6
4.0	719.9	134.4	854.0	5.4	682.0	150.8	832.0	4.5	643.3	168.4	811.0	3.8

NOTES:

1. **KW_o** = Unit kW Cooling Capacity Output
2. **KW_i** = Compressor kW Input
3. **KW** = Condenser Heat Rejection
4. **COP** = Coefficient of Performance
5. **LCWT** = Leaving Chilled Water Temperature
6. Ratings based on 0.047 l/s cooler water per kW.

Part Load Ratings

English

YCWS0100SC			
Load	Tons	kW	EER
1.0	91.3	72.0	15.2
0.8	68.5	51.5	16.0
0.5	45.7	24.5	22.3
0.3	22.8	17.4	15.8
IPLV:18.8			

YCWS0120SC			
Load	Tons	kW	EER
1.0	110.3	86.2	15.4
0.8	82.7	61.4	16.2
0.5	55.1	31.3	21.2
0.3	27.6	23.4	14.1
IPLV:18.2			

YCWS0140SC			
Load	Tons	kW	EER
1.0	130.5	100.5	15.6
0.8	97.9	71.4	16.5
0.5	65.3	34.3	22.8
0.3	32.6	24.5	16.0
IPLV:19.3			

YCWS0180SC			
Load	Tons	kW	EER
1.0	160.3	112.0	17.2
0.8	120.2	79.4	18.2
0.5	80.2	39.2	24.6
0.3	40.1	28.7	16.8
IPLV:20.9			

YCWS0200SC			
Load	Tons	kW	EER
1.0	183.2	126.0	17.5
0.8	137.4	89.5	18.4
0.5	91.6	42.1	26.1
0.3	45.8	30.4	18.1
IPLV:21.8			

YCWS0220SC			
Load	Tons	kW	EER
1.0	199.6	138.8	17.3
0.8	149.7	98.6	18.2
0.5	99.8	48.9	24.5
0.3	49.9	36.1	16.6
IPLV:20.8			

YCWS0240SC			
Load	Tons	kW	EER
1.0	215.4	151.8	15.2
0.8	161.5	107.8	16.0
0.5	107.7	51.1	22.3
0.3	53.8	37.0	15.8
IPLV:21.2			

SI

YCWS0100SC			
Load	kWo	kWi	COP
1.0	321.1	72.0	4.5
0.8	240.8	51.5	4.7
0.5	160.6	24.5	6.5
0.3	80.3	17.4	4.6
5.51			

YCWS0120SC			
Load	kWo	kWi	COP
1.0	387.9	86.2	4.5
0.8	290.9	61.4	4.7
0.5	193.9	31.3	6.2
0.3	97.0	23.4	4.1
5.32			

YCWS0140SC			
Load	kWo	kWi	COP
1.0	459.0	100.5	4.6
0.8	344.2	71.4	4.8
0.5	229.5	34.3	6.7
0.3	114.6	24.5	4.7
5.65			

YCWS0180SC			
Load	kWo	kWi	COP
1.0	563.8	112.0	5.0
0.8	422.9	79.4	5.3
0.5	281.9	39.2	7.2
0.3	141.0	28.7	4.9
6.11			

YCWS0200SC			
Load	kWo	kWi	COP
1.0	644.4	126.0	5.1
0.8	483.3	89.5	5.4
0.5	322.2	42.1	7.7
0.3	161.1	30.4	5.3
6.40			

YCWS0220SC			
Load	kWo	kWi	COP
1.0	702.2	138.8	5.1
0.8	526.6	98.6	5.3
0.5	351.1	48.9	7.2
0.3	175.5	36.1	4.9
6.11			

YCWS0240SC			
Load	kWo	kWi	COP
1.0	757.5	151.8	5.0
0.8	568.1	107.8	5.3
0.5	378.7	51.1	7.4
0.3	189.4	37.0	5.1
6.21			

Glycol Correction Factors

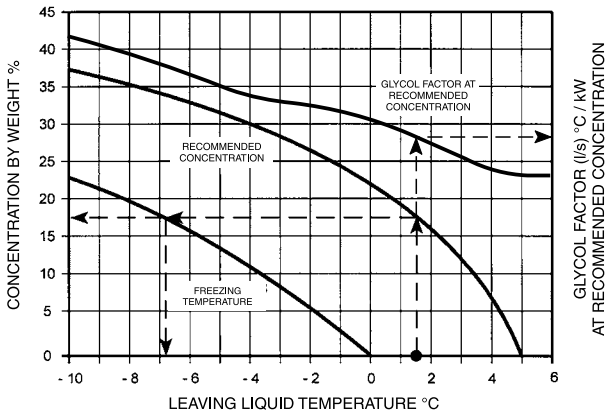

FIGURE 4 - RECOMMENDED CONCENTRATIONS FOR ETHYLENE GLYCOL SOLUTIONS

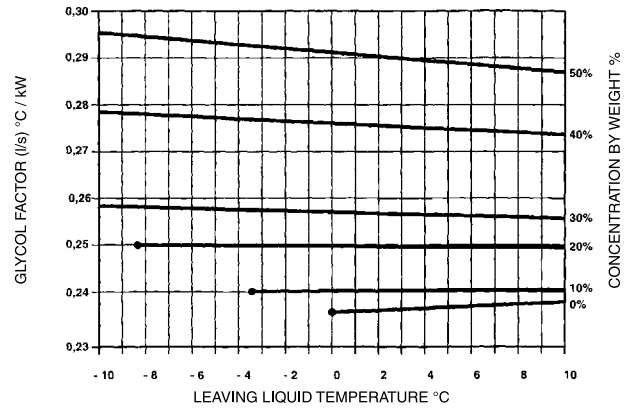

FIGURE 5 - FACTORS AT OTHER CONCENTRATIONS FOR ETHYLENE GLYCOL SOLUTIONS

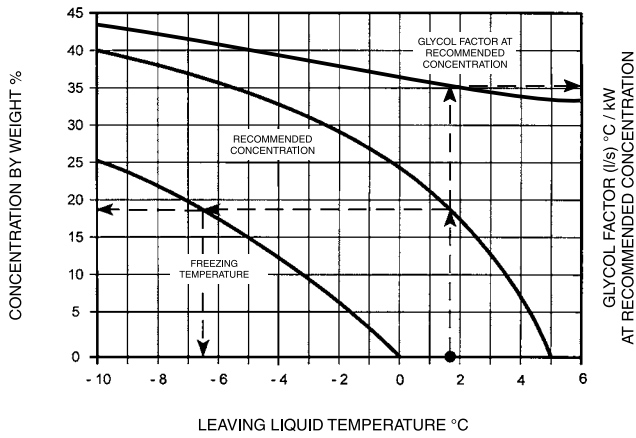

FIGURE 6 - RECOMMENDED CONCENTRATIONS FOR PROPYLENE GLYCOL SOLUTIONS

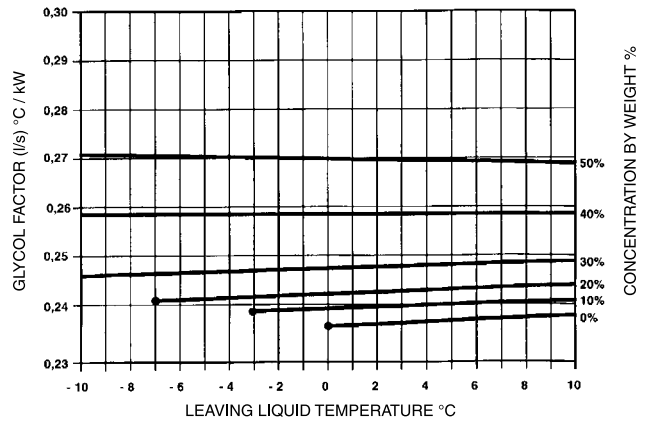

FIGURE 7 - FACTORS AT OTHER CONCENTRATIONS FOR PROPYLENE GLYCOL SOLUTIONS

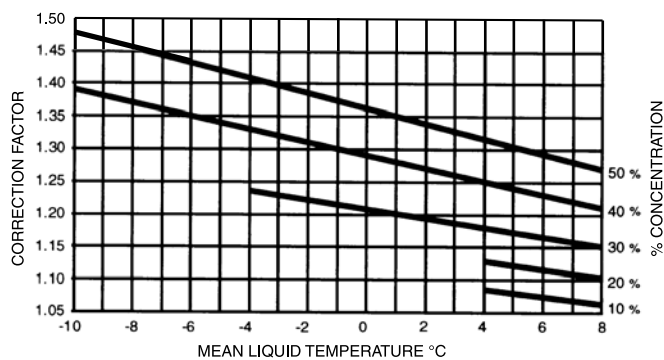

FIGURE 8 - PRESSURE DROP CORRECTION FACTORS FOR ETHYLENE GLYCOL SOLUTIONS

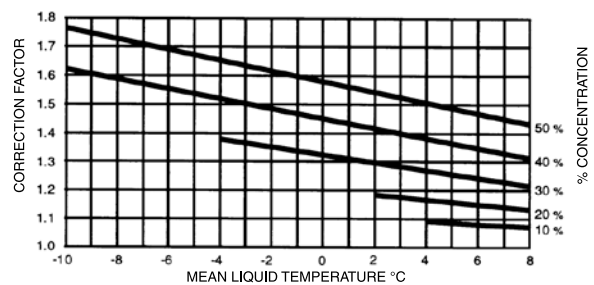

FIGURE 9 - PRESSURE DROP CORRECTION FACTORS FOR PROPYLENE GLYCOL SOLUTIONS

TABLE 1 - CORRECTION FACTORS

% By Weight	Ethylene Glycol (pgs 14 & 15)		Propylene Glycol (pgs 16 & 17)	
	Capacity Factor	Comp. Input Factor (kW)	Capacity Factor	Comp. Input Factor (kW)
10	1.009	1.003	1.011	1.004
20	1.004	1.002	1.006	1.003
30	1.000	1.000	1.000	1.000
40	0.995	0.998	0.988	0.996
50	0.988	0.996	0.975	0.992

Physical Data

MODEL YCWS English Data

	0100SC	0120SC	0140SC	0180SC	0200SC	0220SC	0240SC
General Unit Data							
Nominal Unit Capacity (Tons)	91	110	131	160	183	200	216
Number of Independent Refrigerant Circuits	2	2	2	2	2	2	2
Refrigerant Charge, R22, Ckt 1/Ckt. 2 (lbs.)	100/100	100/120	120/120	210/220	220/220	220/240	240/240
Oil Charge, Ckt. 1/Ckt. 2, (gal.)	2/2	2/3	3/3	3/3	3/3	3/3	3/3
Shipping Weight (lbs.)	7323	7632	7972	11722	11840	11897	12006
Operating Weight (lbs.)	8160	8469	8809	13256	13374	13393	13502

Compressors, Semi-Hermetic Twin Screw

Quantity per Chiller	2	2	2	2	2	2	2
Nominal Size, Ckt. 1/ Ckt. 2	F/F	F/C	C/C	C/A	A/A	A/B	B/B

Condenser - Code

Water Volume (gal.)	26	26	26	61	61	61	61
Maximum Water Side Pressure (psig)	150	150	150	150	150	150	150
Maximum Refrigerant Side Pressure (psig)	330	330	330	330	330	330	330
Dia. X Length, inches	16 x 108	16 x 108	16 x 108	18 x 156	18 x 156	18 x 156	18 x 156
Water Nozzle Connection Size, (inches)	5	5	5	6	6	6	6

Evaporator, Direct Expansion - Code

Water Volume (gals.)	64	64	64	94	94	107	107
Maximum Water Side Pressure (psig)	150	150	150	150	150	150	150
Maximum Refrigerant Side Pressure (psig)	300	300	300	300	300	300	300
Dia. X Length, inches	19-1/2x 108	19-1/2x 108	19-1/2 x 108	21-1/4 x 156	21-1/4x 156	21-1/4x 156	21-1/4 x 156
Water Nozzle Connection Size, (inches)	8	8	8	8	8	8	8

MODEL YCWS SI Data

	0100SC	0120SC	0140SC	0180SC	0200SC	0220SC	0240SC
General Unit Data							
Unit Capacity at 44°F water & 95°F ambient, kW	321	388	461	559	634	695	761
Number of Independent Refrigerant Circuits	2	2	2	2	2	2	2
Refrigerant Charge, R-22, Ckt.-1/Ckt.-2, kg.	39 / 39	39 / 51	51 / 51	61 / 67	67 / 67	69 / 77	77 / 77
Oil Charge, Ckt.-1/Ckt.-2, liters	7.6 / 7.6	7.6 / 11.4	11.4 / 11.4	11.4 / 11.4	11.4 / 11.4	11.4 / 11.4	11.4 / 11.4
Shipping Weight, kg.	3322	3462	3616	5317	5371	5396	5446
Operating Weight, kg.	3701	3841	3996	6013	6066	6075	6124

Compressors, DXS Semihermetic Twin Screw

Quantity per Chiller	2	2	2	2	2	2	2
Nominal Size, Ckt.-1 / Ckt.-2	F/F	F/C	C/C	C/A	A/A	A/B	B/B

Condensers, water-cooled with enhanced tube

DWP Refrigerant Side, MPa	2.3	2.3	2.3	2.3	2.3	2.3	2.3
DWP Water Side, MPa	1.0	1.0	1.0	1.0	1.0	1.0	1.0
Dia. X Length, mm	406 x 2743	406 x 2743	406 x 2743	457 x 3810	457 x 3810	457 x 3963	457 x 3963
Water volume, liters	98	98	98	223	223	230	230
Water connections, mm	127	127	127	152	152	152	152

Evaporator, Direct Expansion

DWP Refrigerant Side, MPa	2.07	2.07	2.07	2.07	2.07	2.07	2.07
DWP Water Side, MPa	1.03	1.03	1.03	1.03	1.03	1.03	1.03
Dia. X Length, mm	495 x 2743	495 x 2743	495 x 2743	518 x 3810	518 x 3810	540 x 3963	540 x 3963
Water volume, liters	242	242	242	357	357	406	406
Water Nozzle Connection Size, (inches)	8	8	8	8	8	8	8

Isolator Selection Data

Weight Distribution by Model Oper. Weight (lbs)

Model	A	B	C	D
YCWS0100SC	1997	1997	2082	2082
YCWS0120SC	2104	2104	2131	2131
YCWS0140SC	2210	2210	2195	2195
YCWS0180SC	3314	3314	3314	3314
YCWS0200SC	3336	3336	3351	3351

Weight Distribution by Model Oper. Weight (kg)

Model	A	B	C	D
YCWS0100SC	906	906	945	945
YCWS0120SC	954	954	967	967
YCWS0140SC	1002	1002	995	995
YCWS0180SC	1503	1503	1503	1503
YCWS0200SC	1513	1513	1520	1520
YCWS0220SC	1512	1512	1526	1526
YCWS0240SC	1522	1522	1540	1540

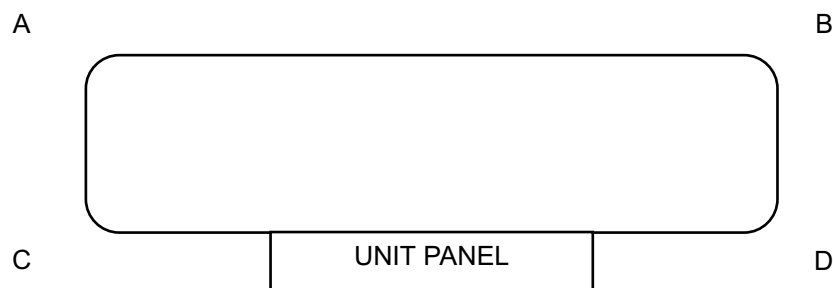

1" Isolator Selections - VMC Type CP-4- X

Model	A	B	C	D
YCWS0100SC	26	26	26	26
YCWS0120SC	26	26	26	26
YCWS0140SC	26	26	26	26
YCWS0180SC	31	31	31	31
YCWS0200SC	31	31	31	31
YCWS0220SC	31	31	31	31
YCWS0240SC	31	31	31	31

Neoprene -VMC Type RD-4 Selections

Model	A	B	C	D
YCWS0100SC	RED	RED	RED	RED
YCWS0120SC	RED	RED	RED	RED
YCWS0140SC	RED	RED	RED	RED
YCWS0180SC	GREEN	GREEN	GREEN	GREEN
YCWS0200SC	GREEN	GREEN	GREEN	GREEN
YCWS0220SC	GREEN	GREEN	GREEN	GREEN
YCWS0240SC	GREEN	GREEN	GREEN	GREEN

Unit Panel Sesmic Isolator AWMR-X- Selections

Model	A	B	C	D
YCWS0100SC	2-530	2-530	2-530	2-530
YCWS0120SC	2-530	2-530	2-530	2-530
YCWS0140SC	2-530	2-530	2-530	2-530
YCWS0180SC	2-552	2-552	2-552	2-552
YCWS0200SC	2-552	2-552	2-552	2-552
YCWS0220SC	2-552	2-552	2-552	2-552
YCWS0240SC	2-552	2-552	2-552	2-552

Isolator Details

1" ISOLATOR DETAILS

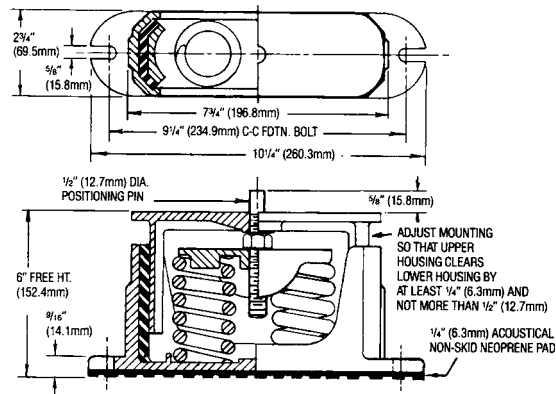

TYPE & SIZE	MAX LOAD		DEFL.		SPRING COLOR
	lbs.	kg	in.	mm	
CP-2-28	1800	816.4	1.02	25.9	Green
CP-2-31	2200	997.9	0.83	21.0	Gray
CP-2-32	2600	1179.3	0.74	18.7	White
CP-2-35	3000	1360.8	0.70	17.7	Gold

NEOPRENE ISOLATOR DETAILS

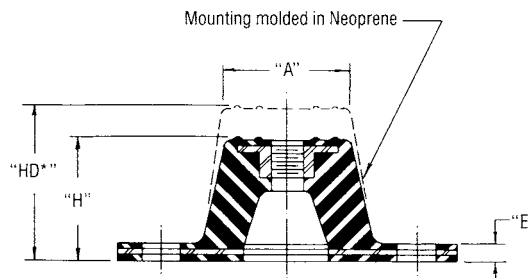
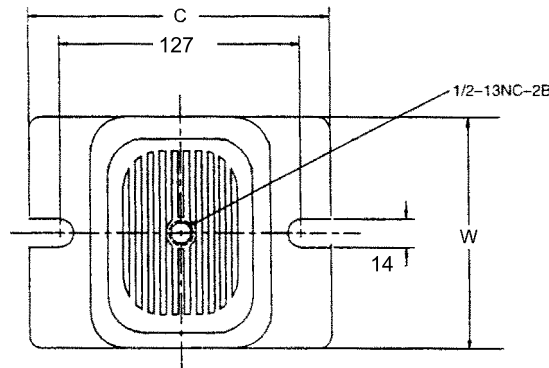

TYPE	A	C	E	H	HD	W
R-4 or RD-4	76	127	10	41	70	118

Sound Data

Sound Pressure Levels (SPL), dB re 20 microPa in accordance with ARI Standard 575-94

MODEL	COMP.	WEIGHTED dB'A'
YCWS0100SC	F-F	77
YCWS0120SC	F-C	78
YCWS0140SC	C-C	79
YCWS0180SC	C-A	80
YCWS0200SC	A-A	81
YCWS0220SC	A-B	82
YCWS0240SC	B-B	83

Note: All 'A' weighted sound pressure data ± 3 dBA

Dimensions - YCWS0100 - English

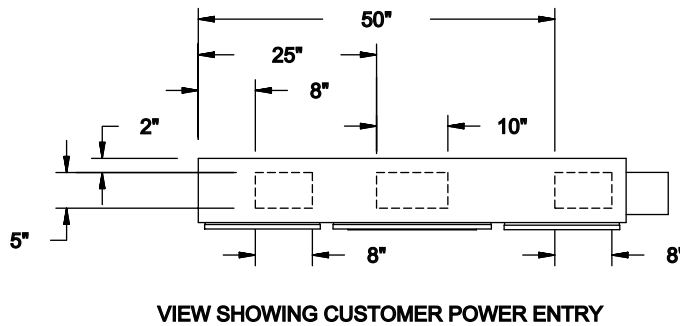
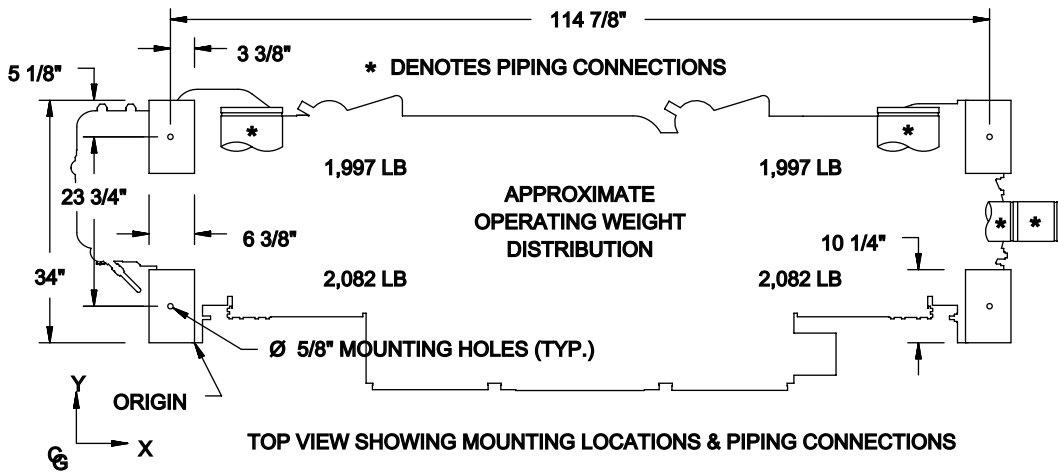

Center of gravity (inches)			
Model	X	Y	Z
YCWS0100SB	57	21	34

NOTES:

1. CLEARANCES - Recommended YORK clearances to service the unit are as follows:

Rear to Wall: 1' 8"
 Front to Wall: 2' 8"
 Top: 1' 8"

Tube cleaning and removal:

Models 100, 120, 140 9' (either end) for Models YCWS0100 thru YCWS0140
 Models 180 - 240 13' (either end) for Models YCWS0180 thru YCWS0240

2. Shipping skids (not shown) will increase the height of the unit by 6", but MUST be removed upon installation.

3. Spring and neoprene isolators will increase the overall height of the unit by approximately 3".

4. Seismic Isolators will increase the overall height of the unit by approximately 9-1/2".

5. To install 1" spring isolators, the feet/brackets in the unit should be flipped over 180 degrees, so that the isolators fit inside the "house".

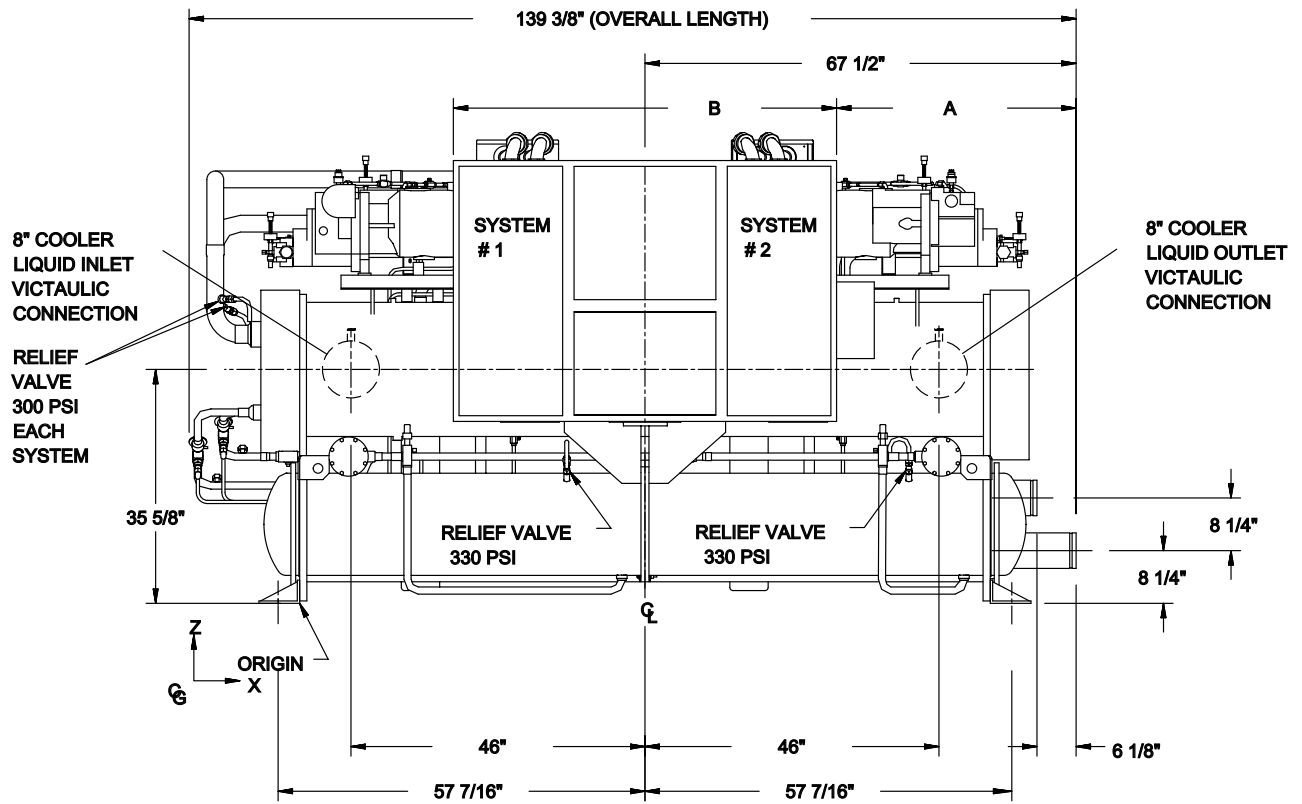

Ref	200/230-3-60	All Other Voltages
A	32-1/4"	37-1/2"
B	70-1/2"	60"
C	48"	40-7/8"
D	80-1/8"	72"

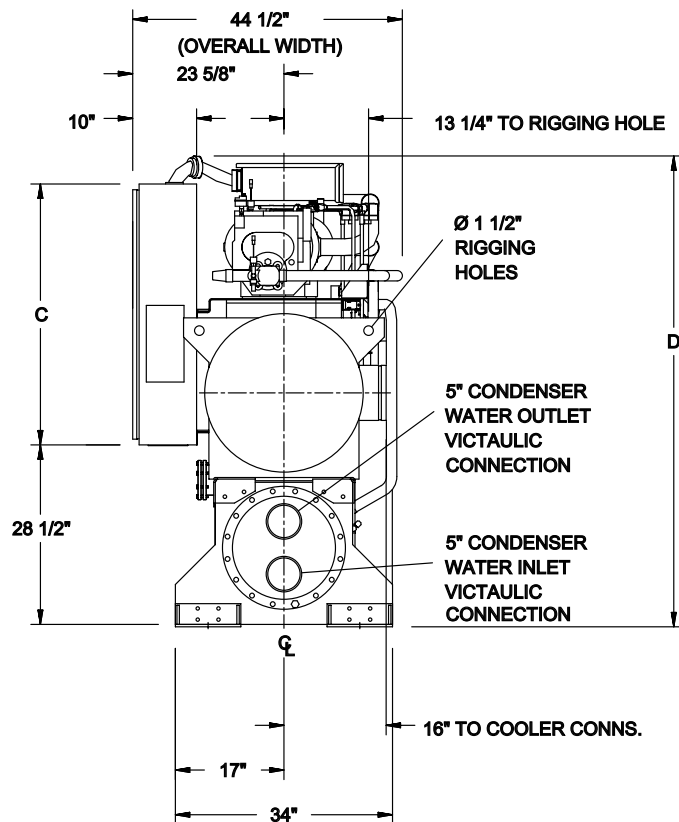

Dimensions - YCWS0120 - English

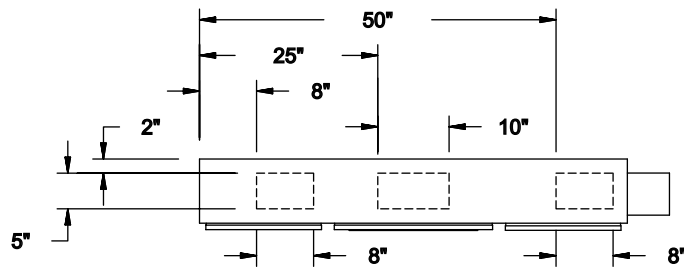
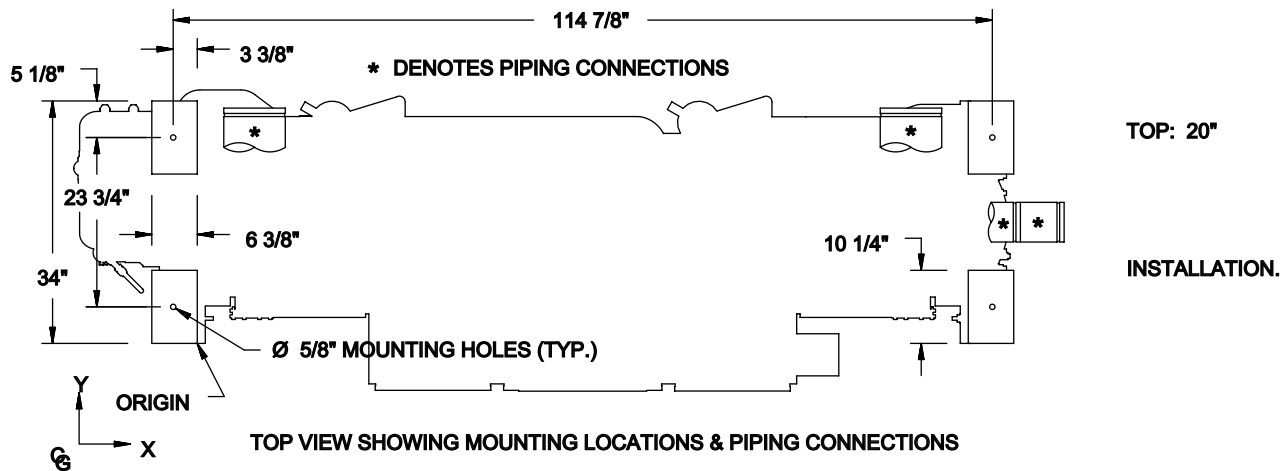

VIEW SHOWING CUSTOMER POWER ENTRY LOCATIONS ON UNDERSIDE OF PANEL

Center of gravity (inches)			
Model	X	Y	Z
YCWS0120SB	58	22	34

NOTES:

1. CLEARANCES - Recommended YORK clearances to service the unit are as follows:

Rear to Wall: 1' 8"

Front to Wall: 2' 8"

Top: 1' 8"

Tube cleaning and removal:

Models 100, 120, 140 9' (either end) for Models YCWS0100 thru YCWS0140

Models 180 - 240 13' (either end) for Models YCWS0180 thru YCWS0240

2. Shipping skids (not shown) will increase the height of the unit by 6", but MUST be removed upon installation.
3. Spring and neoprene isolators will increase the overall height of the unit by approximately 3".
4. Seismic Isolators will increase the overall height of the unit by approximately 9-1/2".
5. To install 1" spring isolators, the feet/brackets in the unit should be flipped over 180 degrees, so that the isolators fit inside the "house".

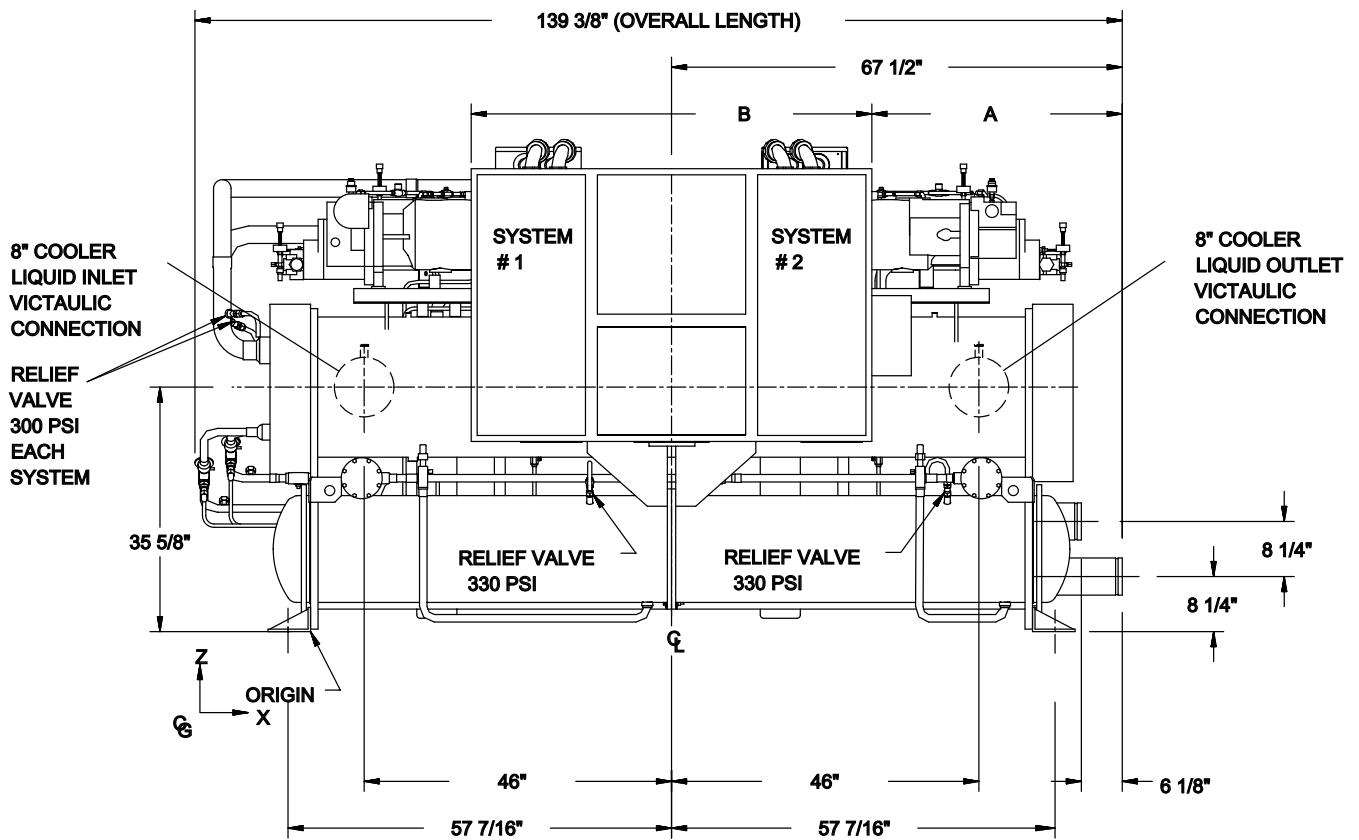

Ref	200/230-3-60	All Other Voltages
A	32-1/4"	37-1/2"
B	70-1/2"	60"
C	48"	40-7/8"
D	80-7/8"	74-17/32"

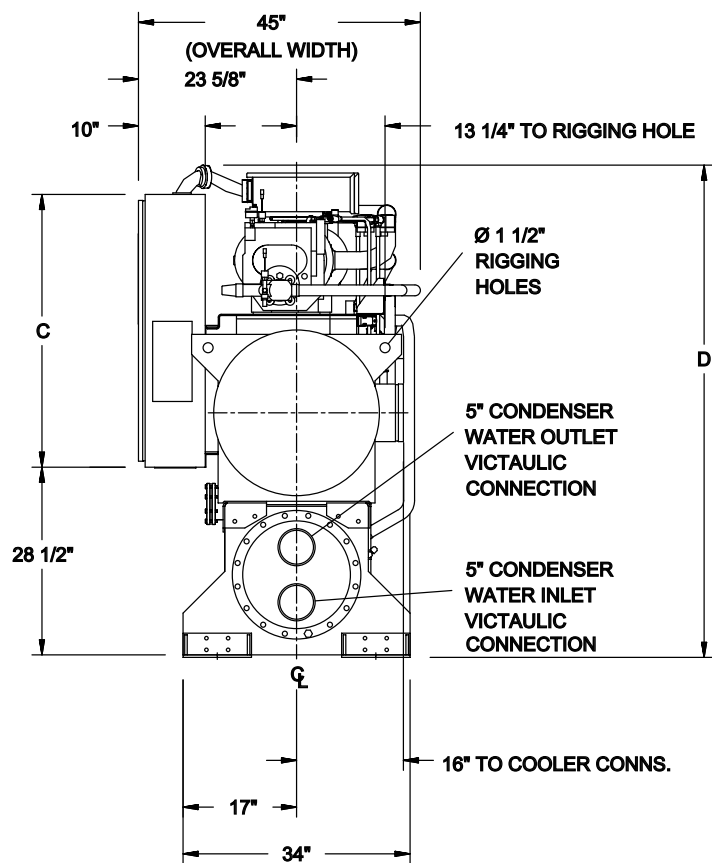

Dimensions - YCWS0140 - English

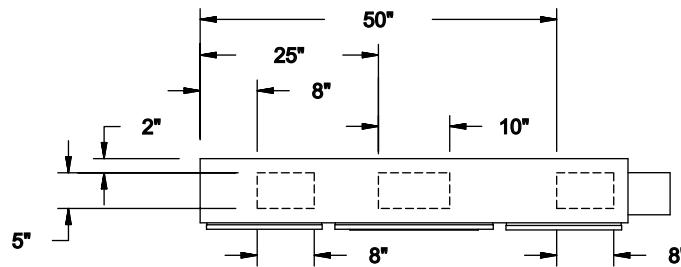
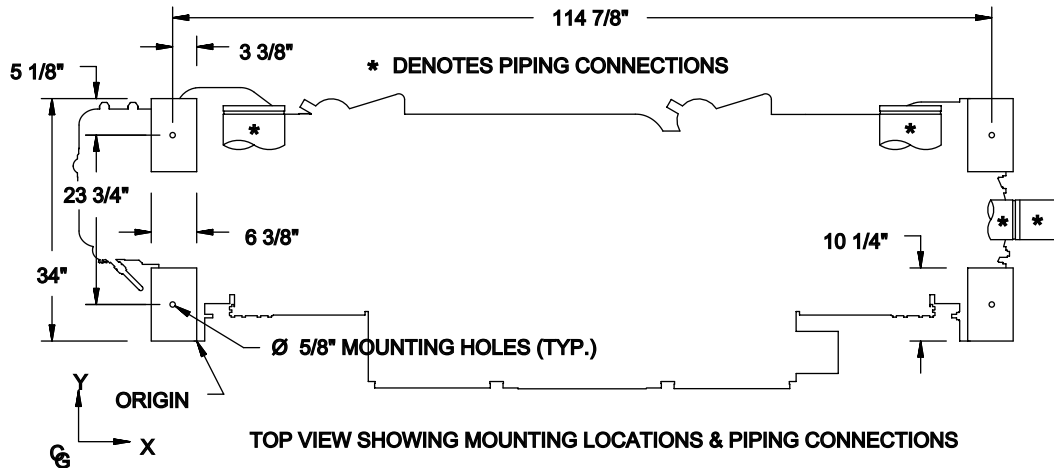

Center of gravity (inches)			
Model	X	Y	Z
YCWS0140SB	57	22	34

NOTES:

1. CLEARANCES - Recommended YORK clearances to service the unit are as follows:

Rear to Wall: 1' 8"
 Front to Wall: 2' 8"
 Top: 1' 8"

Tube cleaning and removal:

Models 100, 120, 140 9' (either end) for Models YCWS0100 thru YCWS0140
 Models 180 - 240 13' (either end) for Models YCWS0180 thru YCWS0240

2. Shipping skids (not shown) will increase the height of the unit by 6", but MUST be removed upon installation.
3. Spring and neoprene isolators will increase the overall height of the unit by approximately 3".
4. Seismic Isolators will increase the overall height of the unit by approximately 9-1/2".
5. To install 1" spring isolators, the feet/brackets in the unit should be flipped over 180 degrees, so that the isolators fit inside the "house".

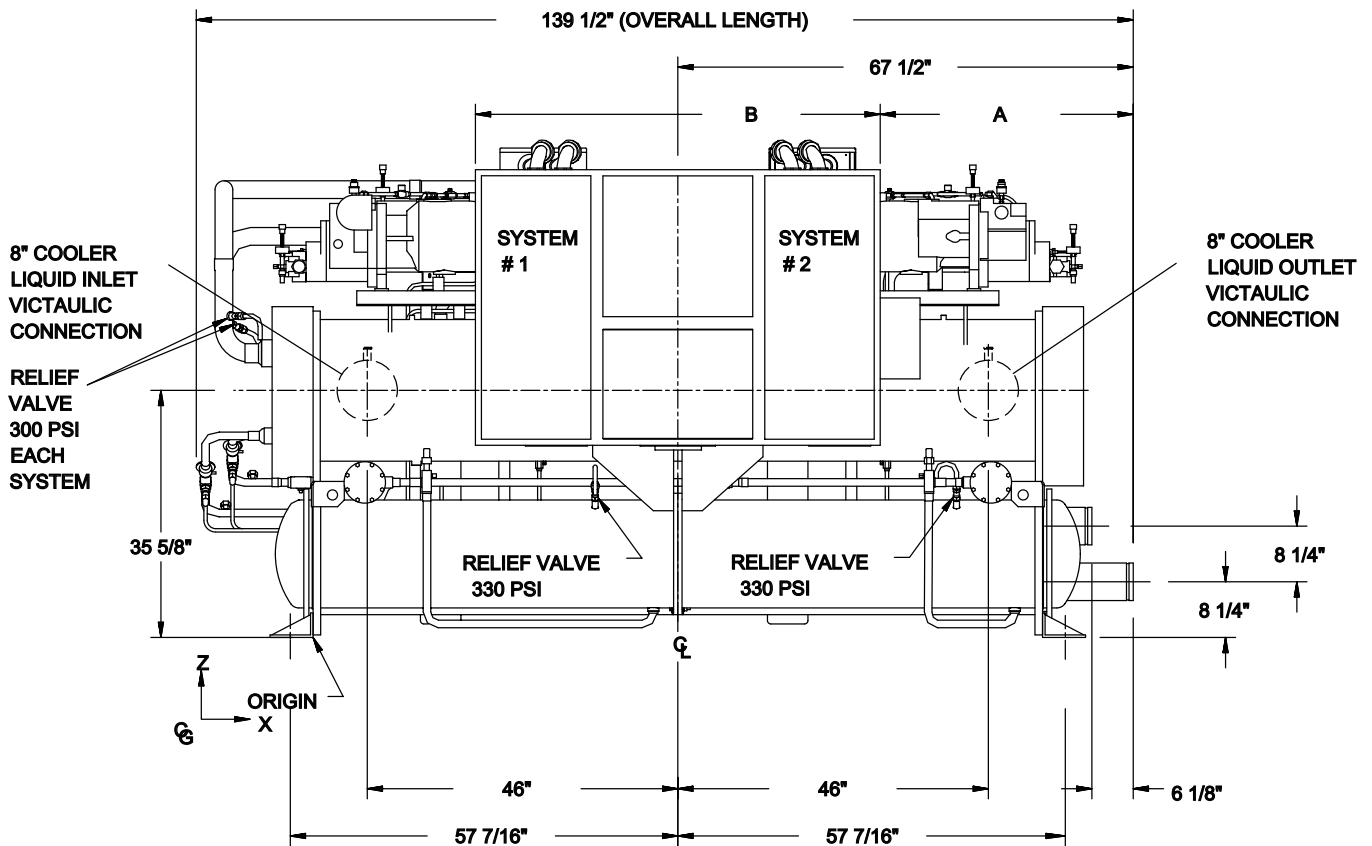

Ref	200/230-3-60	All Other Voltages
A	32-1/4"	37-1/2"
B	70-1/2"	60"
C	48"	40-7/8"
D	80-7/8"	74-17/32"

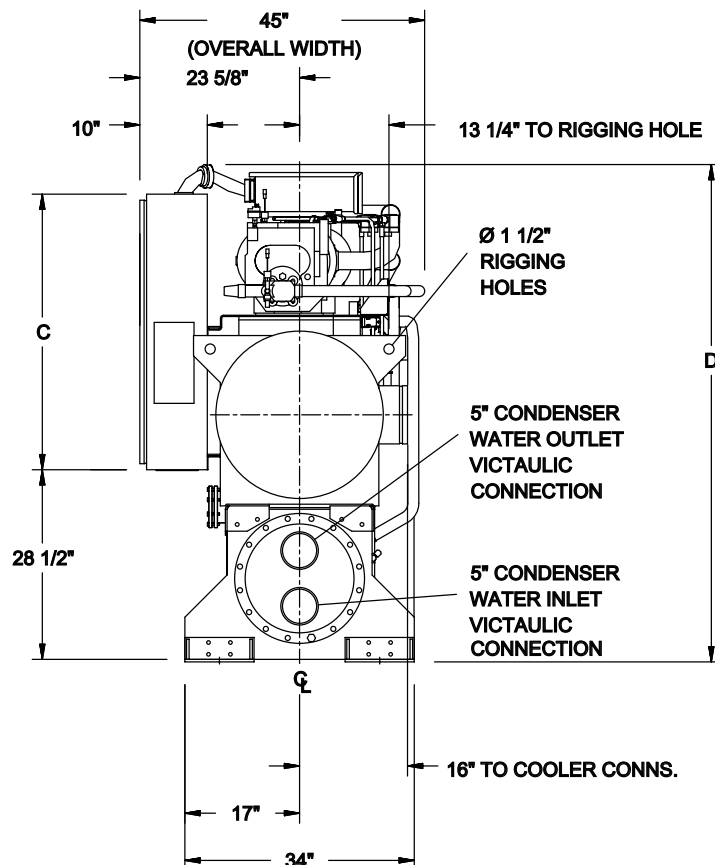

Dimensions - YCWS0180 - English

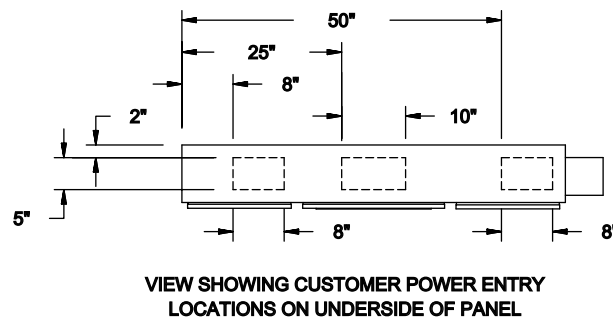
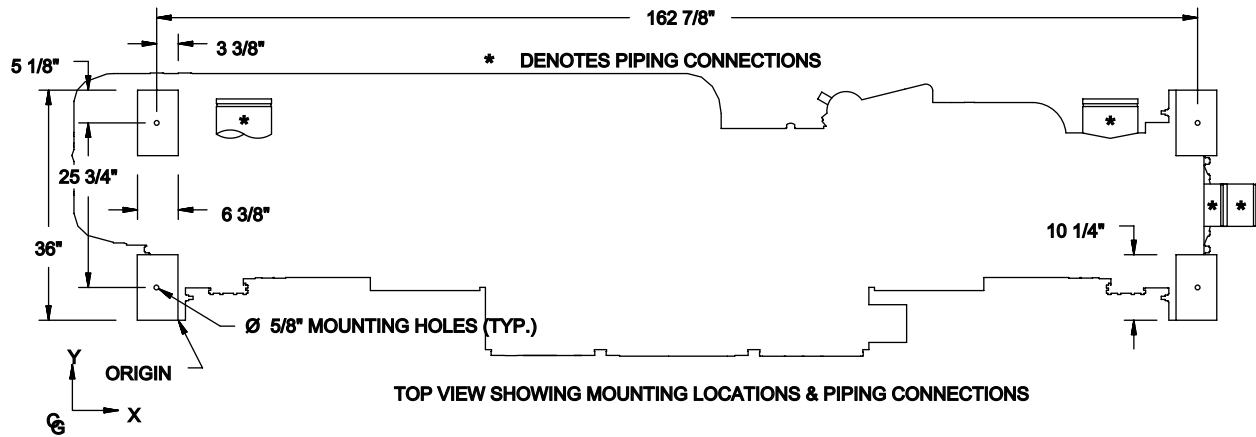

Center of gravity (inches)			
Model	X	Y	Z
YCWS0180SB	80	24	36

NOTES:

1. CLEARANCES - Recommended YORK clearances to service the unit are as follows:

Rear to Wall: 1' 8"

Front to Wall: 2' 8"

Top: 1' 8"

Tube cleaning and removal:

Models 100, 120, 140 9' (either end) for Models YCWS0100 thru YCWS0140

Models 180 - 240 13' (either end) for Models YCWS0180 thru YCWS0240

2. Shipping skids (not shown) will increase the height of the unit by 6", but MUST be removed upon installation.

3. Spring and neoprene isolators will increase the overall height of the unit by approximately 3".

4. Seismic Isolators will increase the overall height of the unit by approximately 9-1/2".

5. To install 1" spring isolators, the feet/brackets in the unit should be flipped over 180 degrees, so that the isolators fit inside the "house".

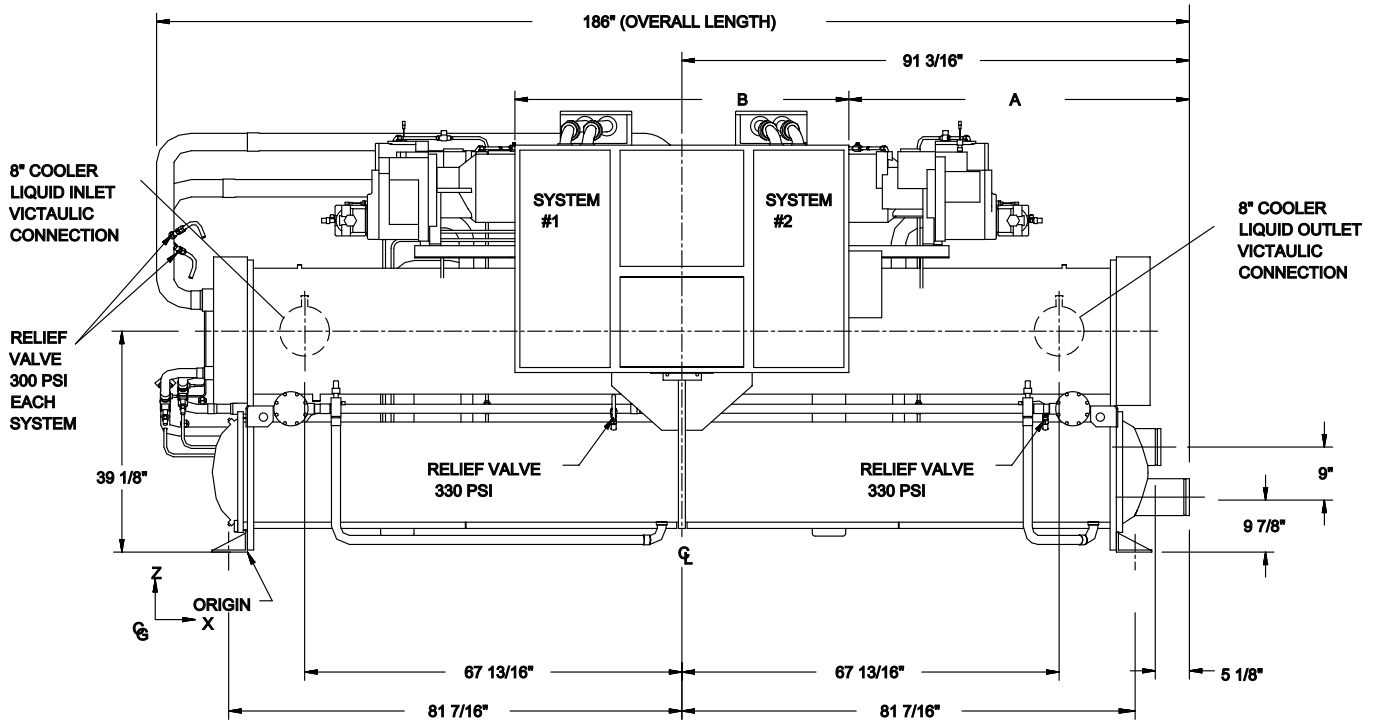

Ref	200/230-3-60	All Other Voltages
A	56"	61-1/4"
B	70-1/2"	60"
C	48"	40-7/8"
D	84-1/2"	79-1/8"

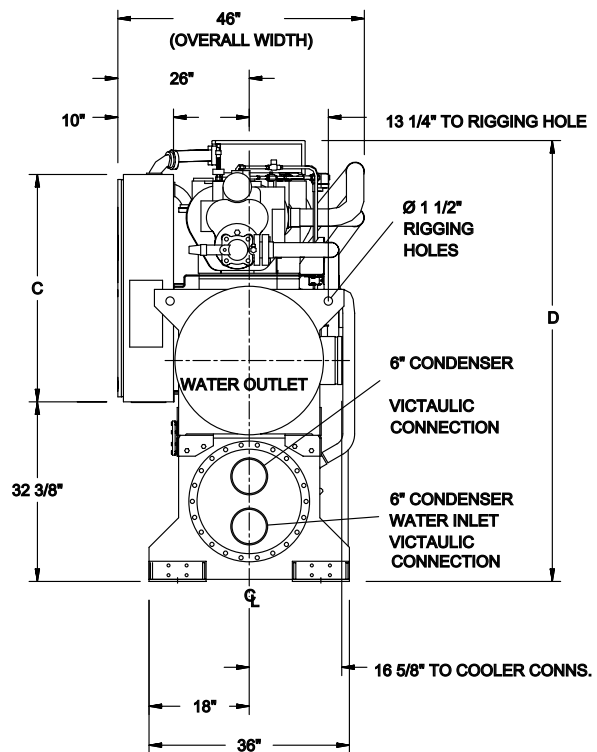

Dimensions - YCWS0200 - English

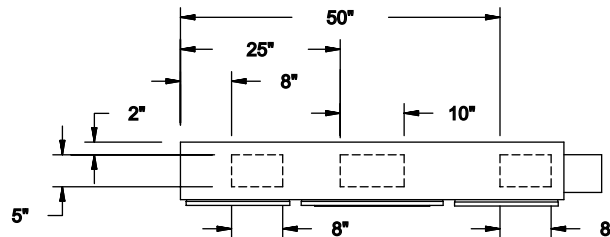
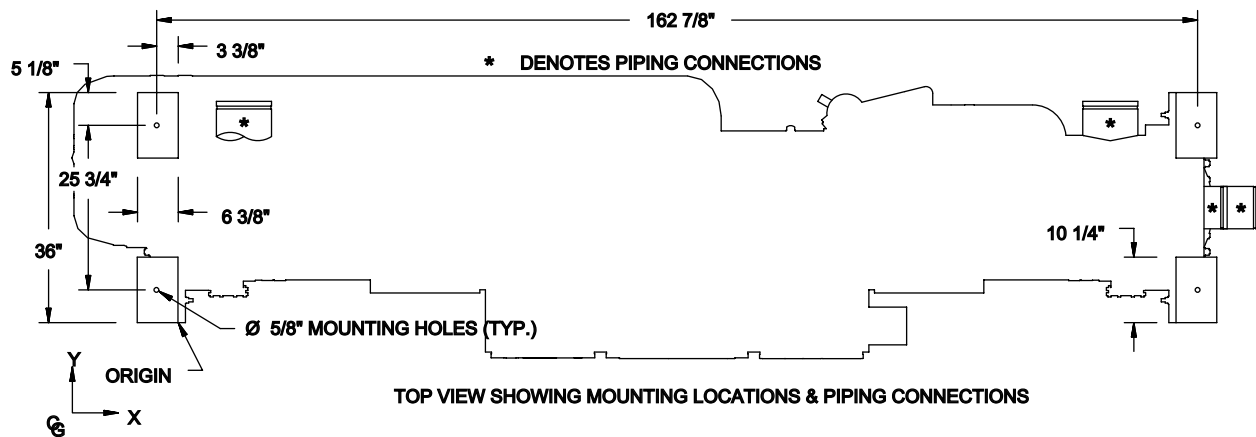

Center of gravity (inches)			
Model	X	Y	Z
YCWS0200SB	80	24	36

NOTES:

1. CLEARANCES - Recommended YORK clearances to service the unit are as follows:

Rear to Wall: 1' 8"
 Front to Wall: 2' 8"
 Top: 1' 8"

Tube cleaning and removal:

Models 100, 120, 140 9' (either end) for Models YCWS0100 thru YCWS0140
 Models 180 - 240 13' (either end) for Models YCWS0180 thru YCWS0240

2. Shipping skids (not shown) will increase the height of the unit by 6", but MUST be removed upon installation.
3. Spring and neoprene isolators will increase the overall height of the unit by approximately 3".
4. Seismic Isolators will increase the overall height of the unit by approximately 9-1/2".
5. To install 1" spring isolators, the feet/brackets in the unit should be flipped over 180 degrees, so that the isolators fit inside the "house".

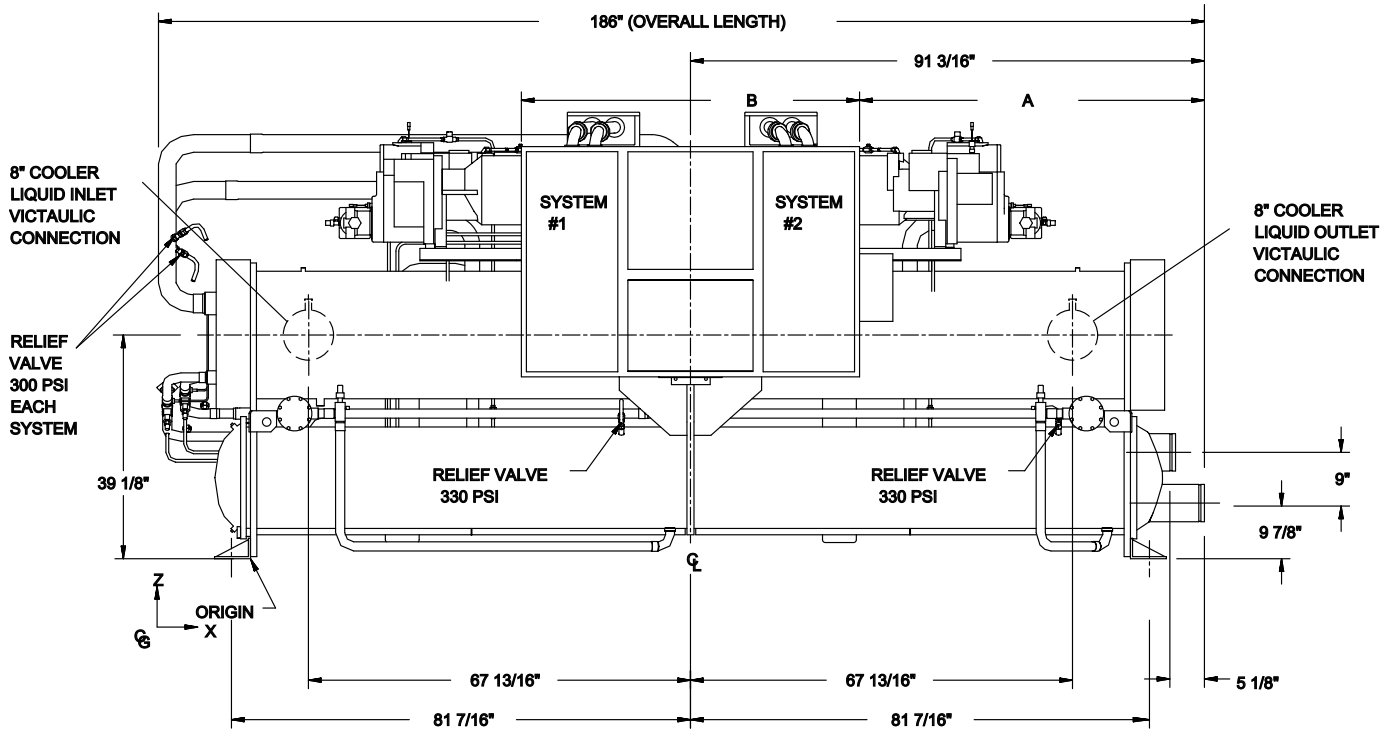

Ref	200/230-3-60	All Other Voltages
A	56"	61-1/4"
B	70-1/2"	60"
C	48"	40-7/8"
D	84-1/2"	79-1/8"

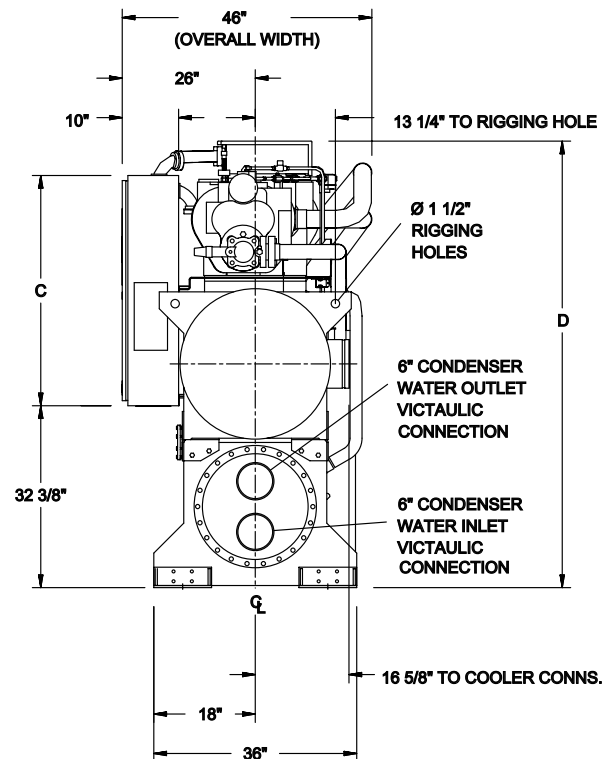

Dimensions - YCWS0220 - English

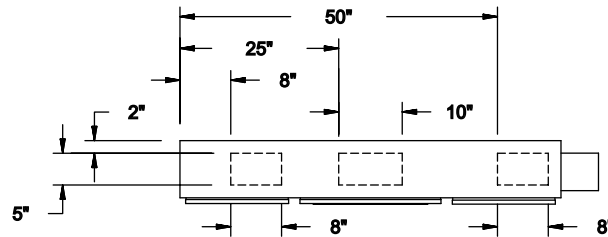
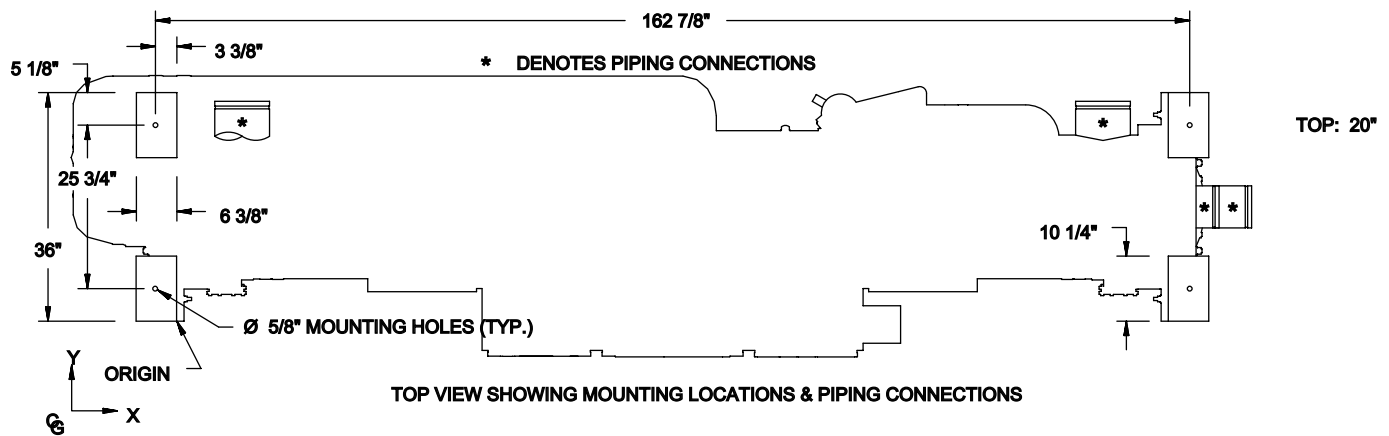

Center of gravity (inches)			
Model	X	Y	Z
YCWS0220SB	80	24	37

NOTES:

- CLEARANCES** - Recommended YORK clearances to service the unit are as follows:

Rear to Wall:	1' 8"
Front to Wall:	2' 8"
Top:	1' 8"

 Tube cleaning and removal:

Models 100, 120, 140	9' (either end) for Models YCWS0100 thru YCWS0140
Models 180 - 240	13" (either end) for Models YCWS0180 thru YCWS0240
- Shipping skids (not shown) will increase the height of the unit by 6", but MUST be removed upon installation.
- Spring and neoprene isolators will increase the overall height of the unit by approximately 3".
- Seismic isolators will increase the overall height of the unit by approximately 9-1/2".
- To install 1" spring isolators, the feet/brackets in the unit should be flipped over 180 degrees, so that the isolators fit inside the "house".

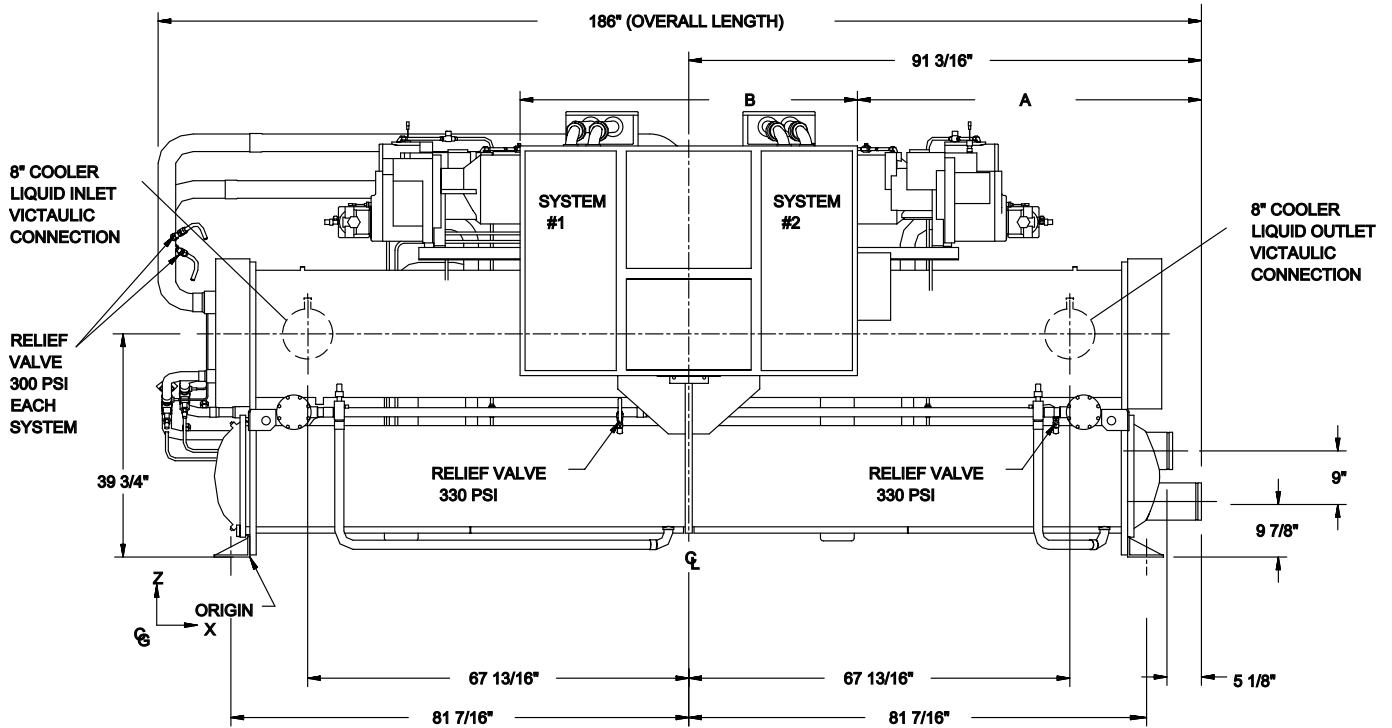

Ref	200/230-3-60	All Other Voltages
A	56"	61-1/4"
B	70-1/2"	60"
C	48"	40-7/8"
D	84-1/2"	79-1/8"

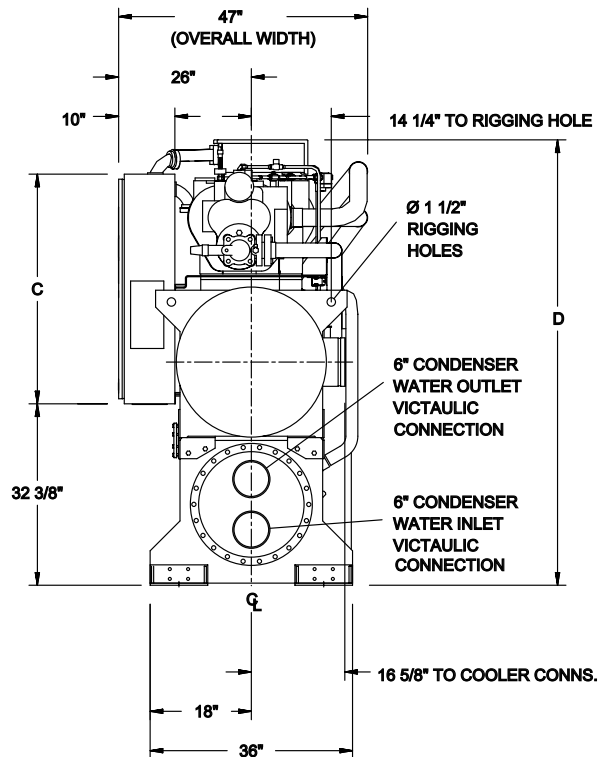

Dimensions - YCWS0240 - English

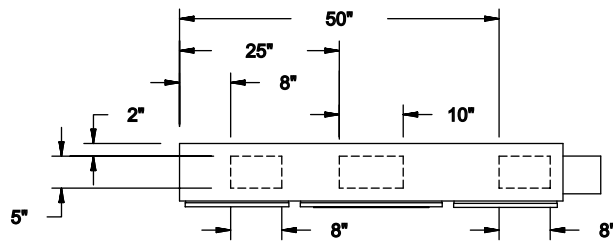
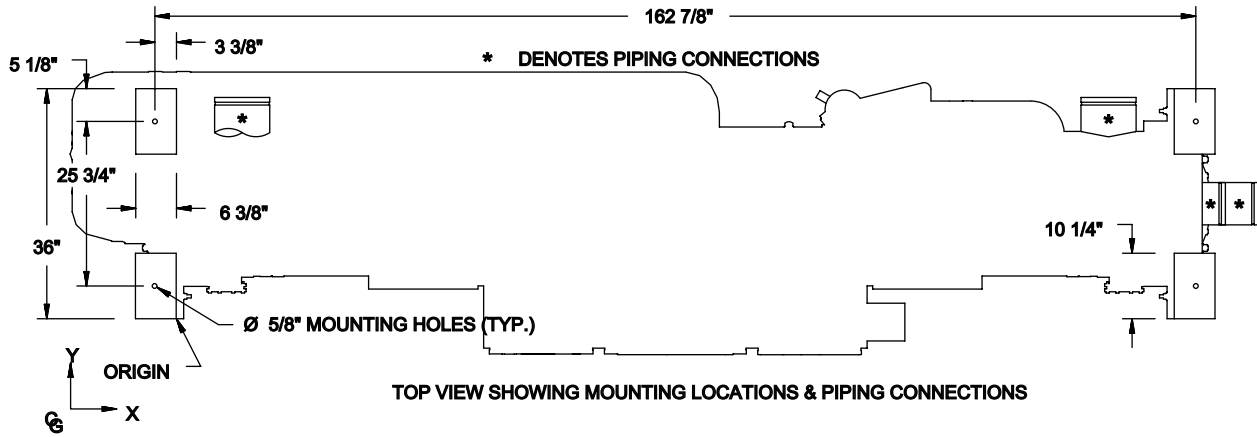

Center of gravity (inches)			
Model	X	Y	Z
YCWS0240SB	80	24	37

NOTES:

- CLEARANCES - Recommended YORK clearances to service the unit are as follows:
 - Rear to Wall: 1' 8"
 - Front to Wall: 2' 8"
 - Top: 1' 8"
 - Tube cleaning and removal:
 - Models 100, 120, 140 9' (either end) for Models YCWS0100 thru YCWS0140
 - Models 180 - 240 13' (either end) for Models YCWS0180 thru YCWS0240
- Shipping skids (not shown) will increase the height of the unit by 6", but MUST be removed upon installation.
- Spring and neoprene isolators will increase the overall height of the unit by approximately 3".
- Seismic Isolators will increase the overall height of the unit by approximately 9-1/2".
- To install 1" spring isolators, the feet/brackets in the unit should be flipped over 180 degrees, so that the isolators fit inside the "house".

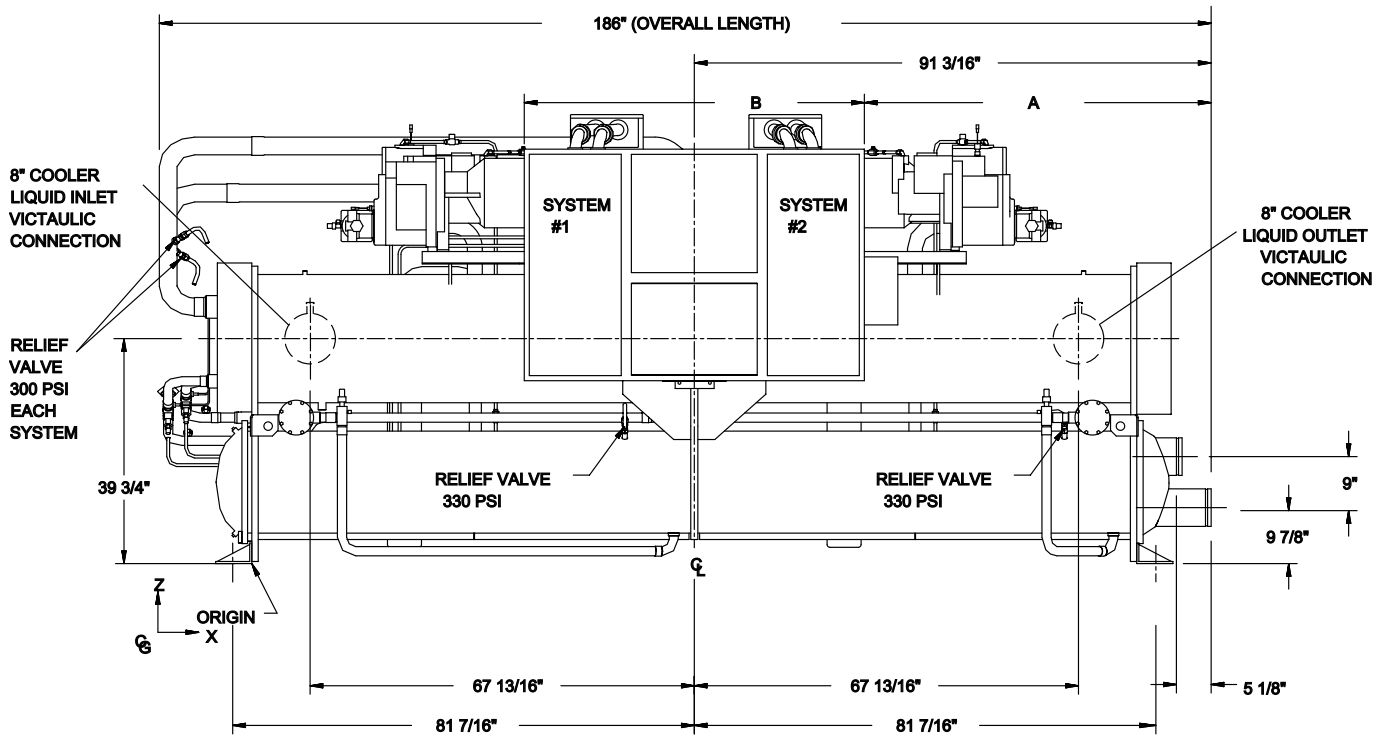

Ref	200/230-3-60	All Other Voltages
A	56"	61-1/4"
B	70-1/2"	60"
C	48"	40-7/8"
D	84-1/2"	79-1/8"

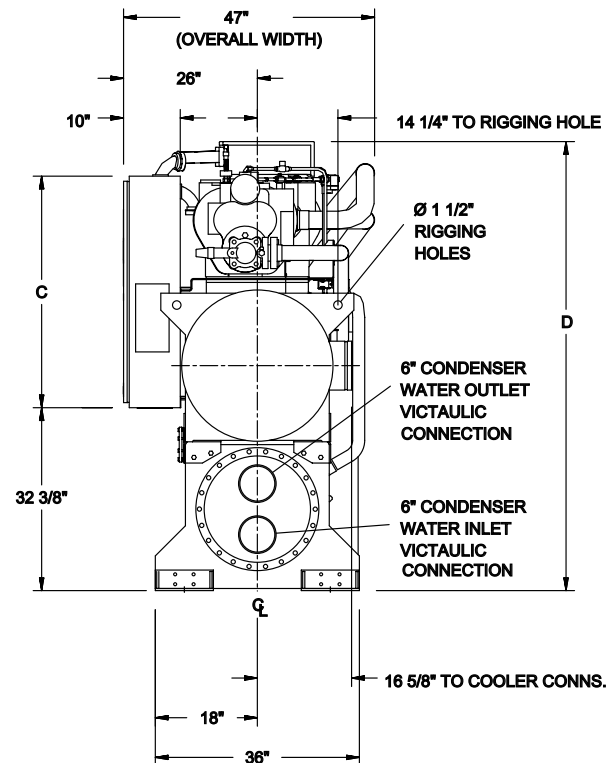

Dimensions - YCWS0100 - SI

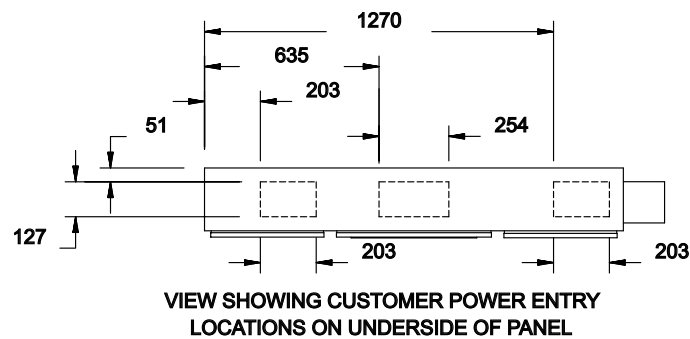
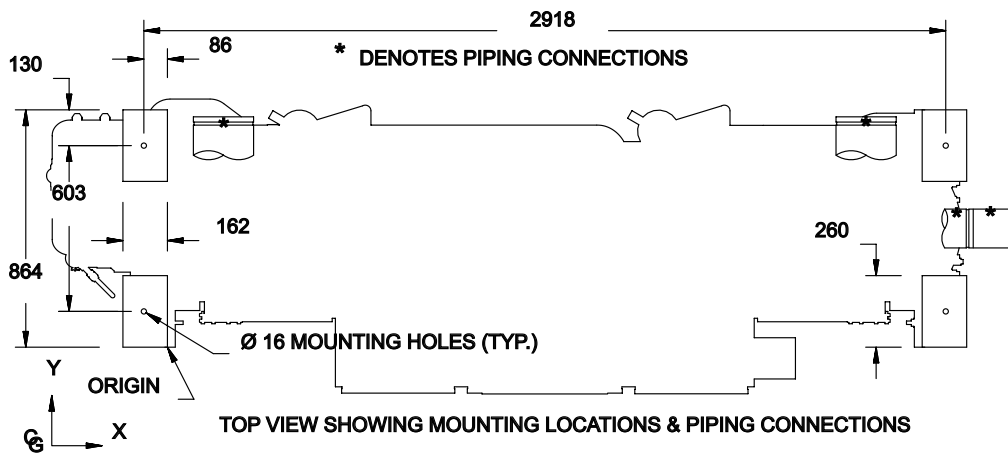

Center of gravity (mm)			
Model	X	Y	Z
YCWS0100SC	1442	545	862

NOTES:

1. CLEARANCES - Recommended YORK clearances to service the unit are as follows:

Rear to Wall: 508mm

Front to Wall: 813mm

Top: 508mm

Tube cleaning and removal:

Models 100, 120, 140 2743mm (either end) for models YCWS0100 thru YCWS0140

Models 180 - 240 3962mm (either end) for models YCWS0180 thru YCWS0240

2. Shipping skids (not shown) will increase the height of the unit by 152mm, but **MUST** be removed upon installation.
3. Spring and neoprene isolators will increase the overall height of the unit by approximately 76mm.
4. Sismic Isolators will increase the overall height of the unit by approximately 241 mm.
5. To install 25mm spring isolators, the feet/brackets in the unit should be flipped over 180 degrees, so the isolators fit inside the "house".

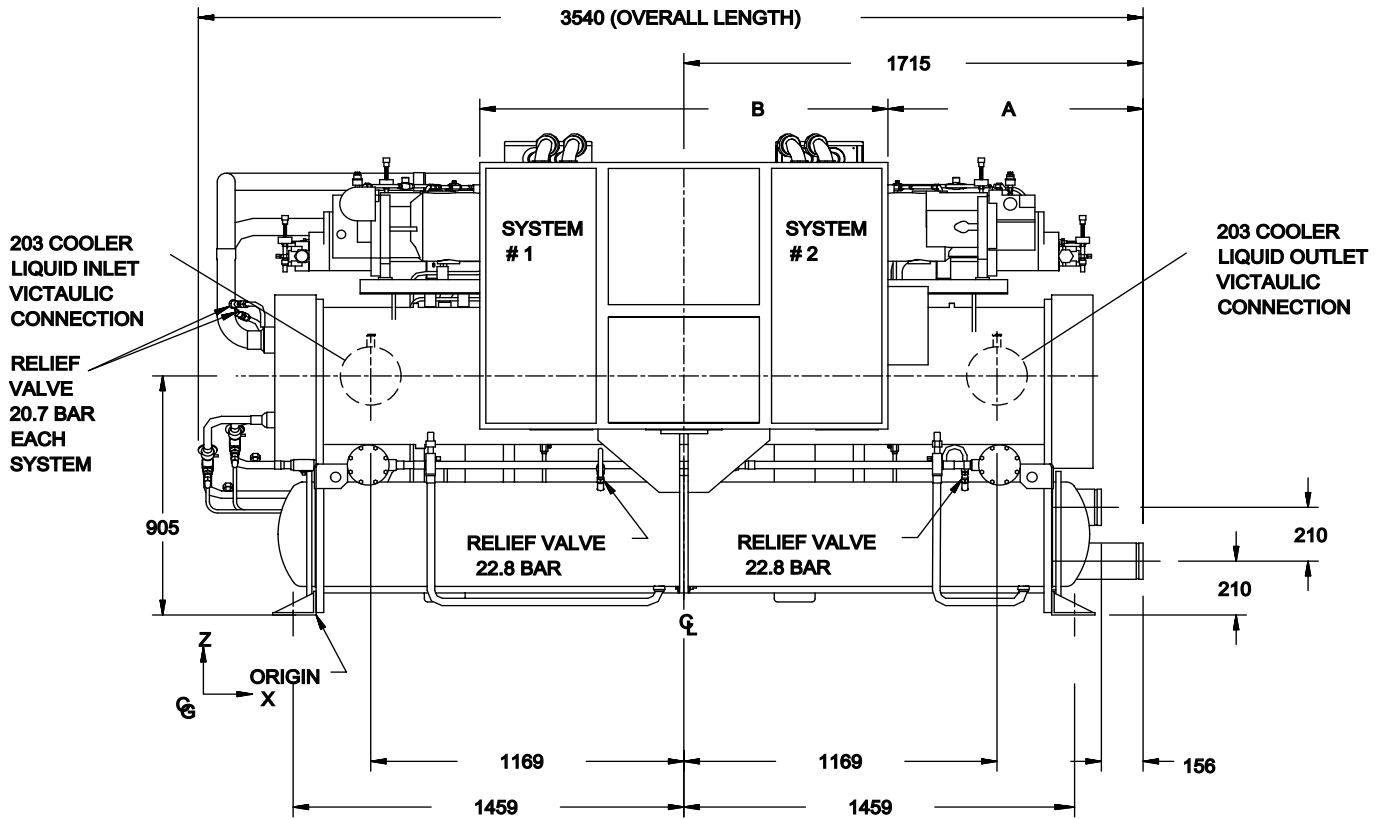

Ref	200/230-3-60	All Other Voltages
A	819	953
B	1791	1524
C	1219	1038
D	2035	1829

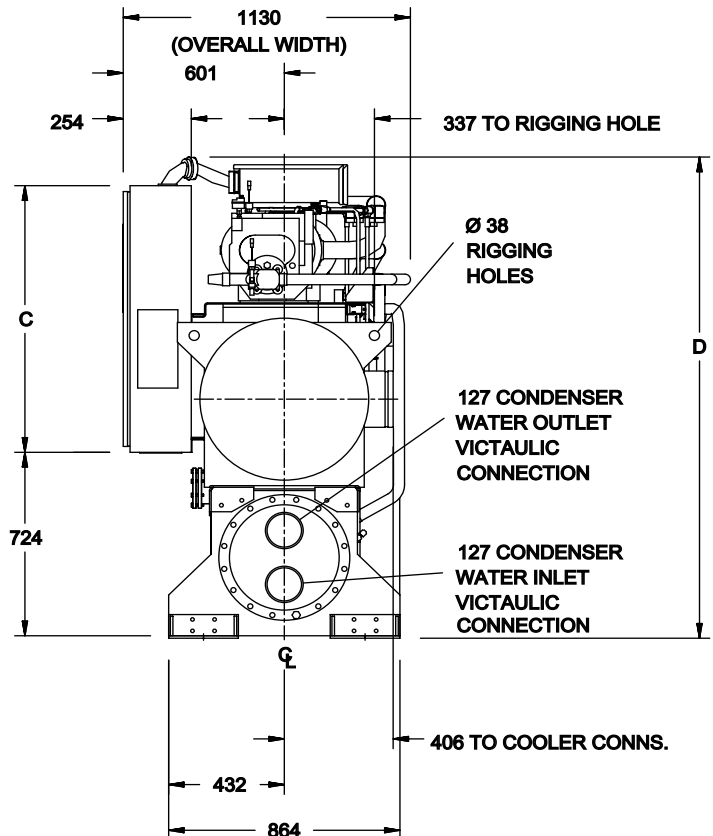

Dimensions - YCWS0120 - SI

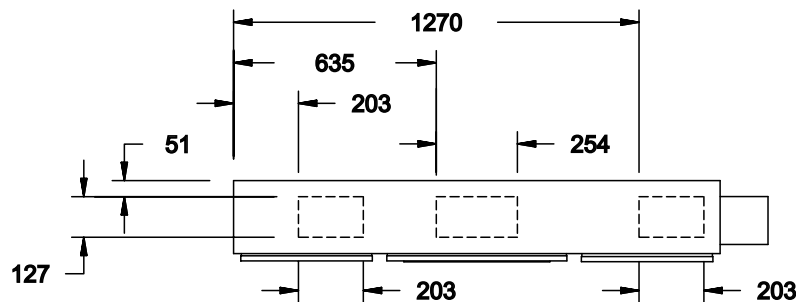
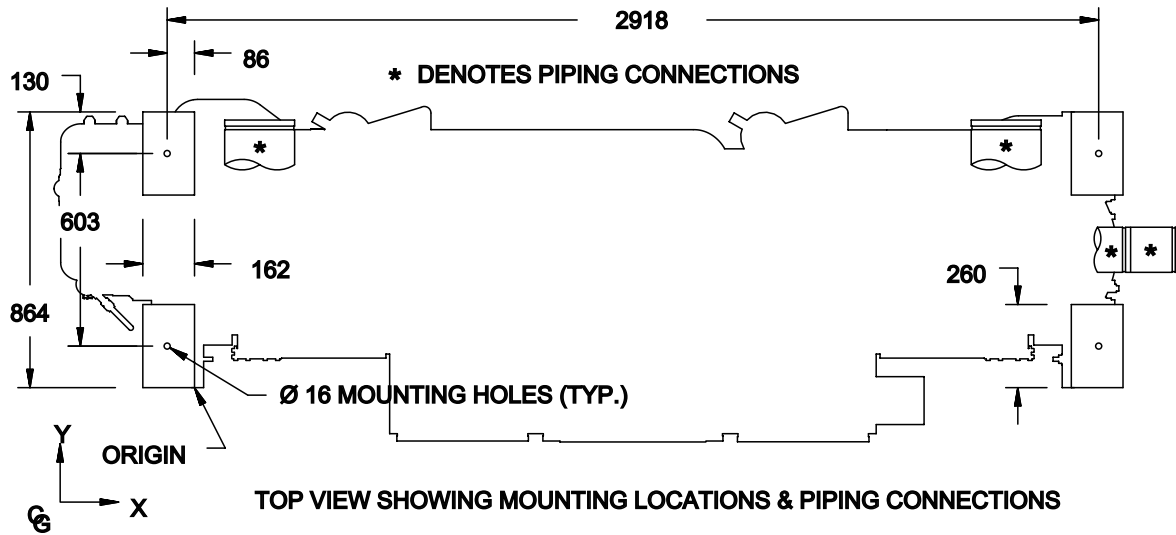

Center of gravity (mm)			
Model	X	Y	Z
YCWS0120SC	1464	550	866

NOTES:

1. CLEARANCES - Recommended YORK clearances to service the unit are as follows:

Rear to Wall: 508mm
 Front to Wall: 813mm
 Top: 508mm

Tube cleaning and removal:

Models 100, 120, 140 2743mm (either end) for models YCWS0100 thru YCWS0140
 Models 180 - 240 3962mm (either end) for models YCWS0180 thru YCWS0240

2. Shipping skids (not shown) will increase the height of the unit by 152mm, but MUST be removed upon installation.

3. Spring and neoprene isolators will increase the overall height of the unit by approximately 76mm.

4. Sismic Isolators will increase the overall height of the unit by approximately 241 mm.

5. To install 25mm spring isolators, the feet/brackets in the unit should be flipped over 180 degrees, so the isolators fit inside the "house".

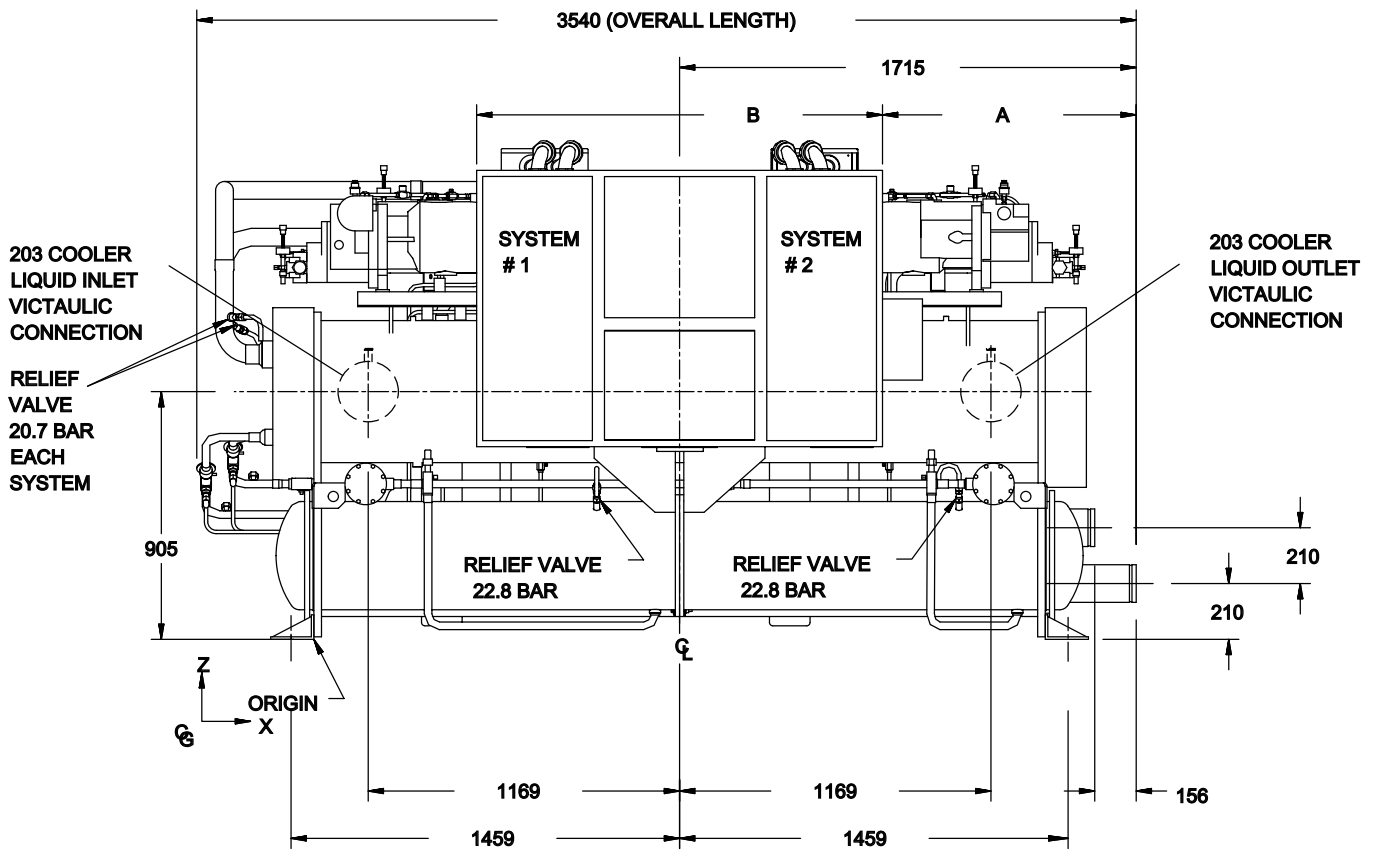

Ref	200/230-3-60	All Other Voltages
A	819	953
B	1791	1524
C	1219	1038
D	2054	1893

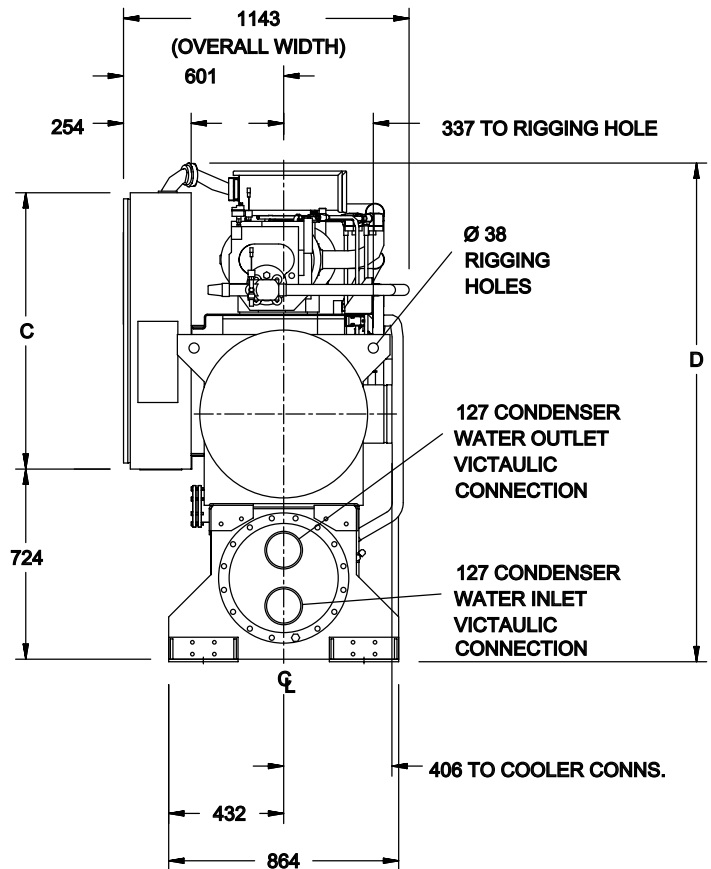

Dimensions - YCWS0140 - SI

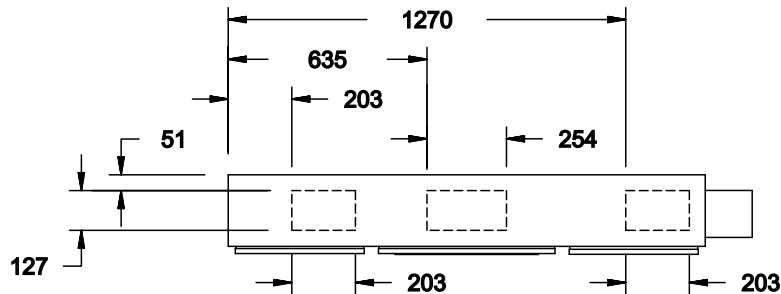
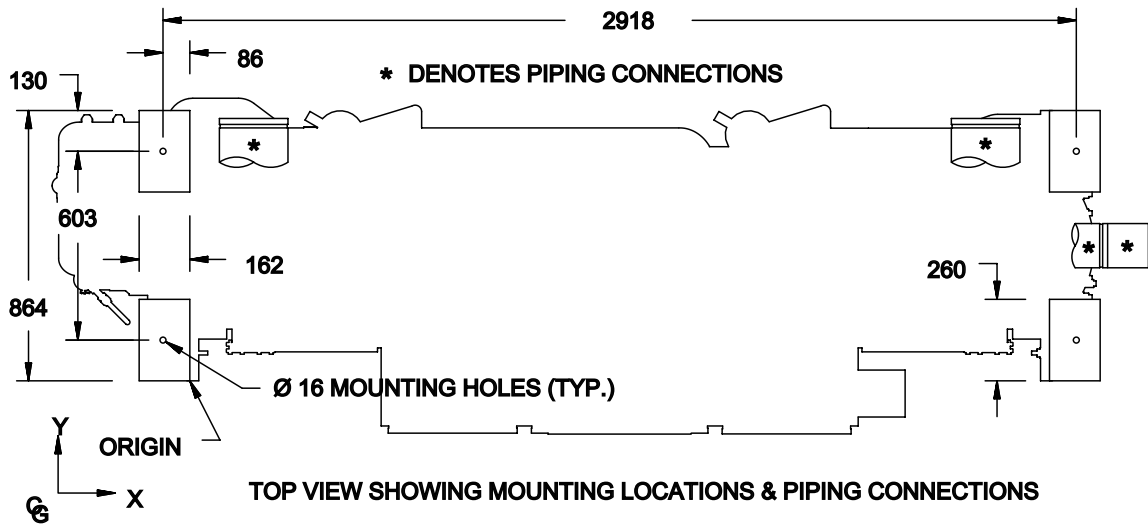

Center of gravity (mm)			
Model	X	Y	Z
YCWS0140SC	1443	554	870

NOTES:

1. CLEARANCES - Recommended YORK clearances to service the unit are as follows:

Rear to Wall: 508mm
 Front to Wall: 813mm
 Top: 508mm

Tube cleaning and removal:

Models 100, 120, 140 2743mm (either end) for models YCWS0100 thru YCWS0140
 Models 180 - 240 3962mm (either end) for models YCWS0180 thru YCWS0240

2. Shipping skids (not shown) will increase the height of the unit by 152mm, but MUST be removed upon installation.
3. Spring and neoprene isolators will increase the overall height of the unit by approximately 76mm.
4. Sismic Isolators will increase the overall height of the unit by approximately 241 mm.
5. To install 25mm spring isolators, the feet/brackets in the unit should be flipped over 180 degrees, so the isolators fit inside the "house".

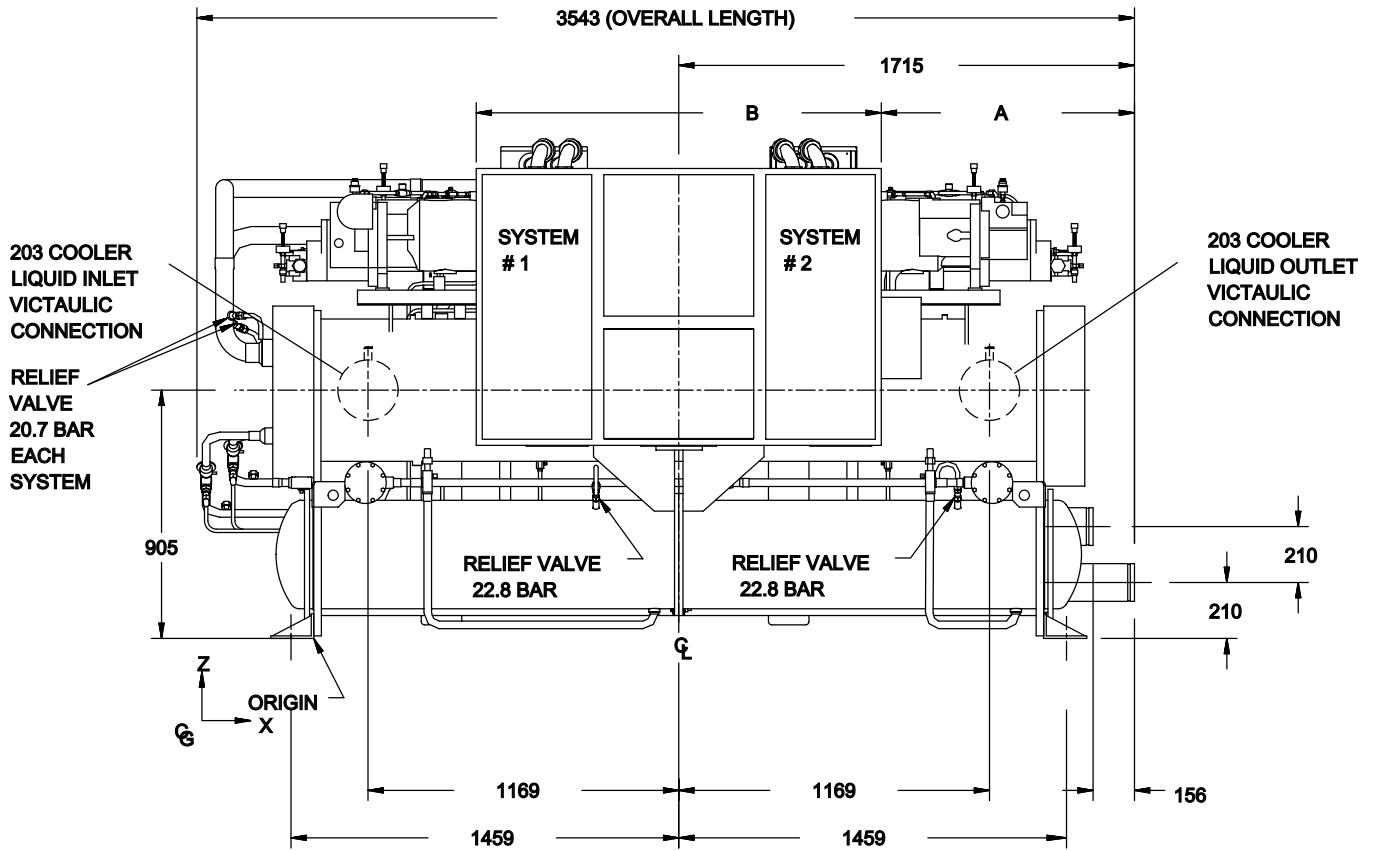

Ref	200/230-3-60	All Other Voltages
A	819	953
B	1791	1524
C	1219	1038
D	2054	1893

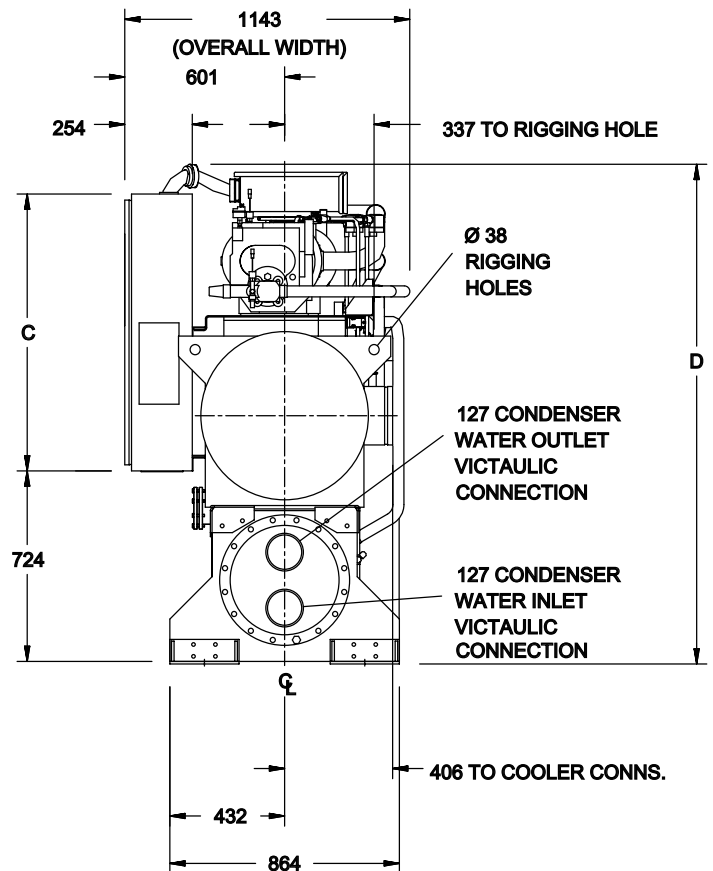

Dimensions - YCWS0180 - SI

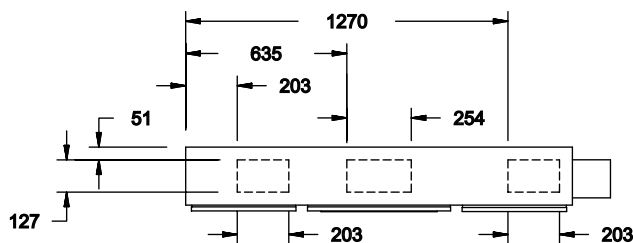
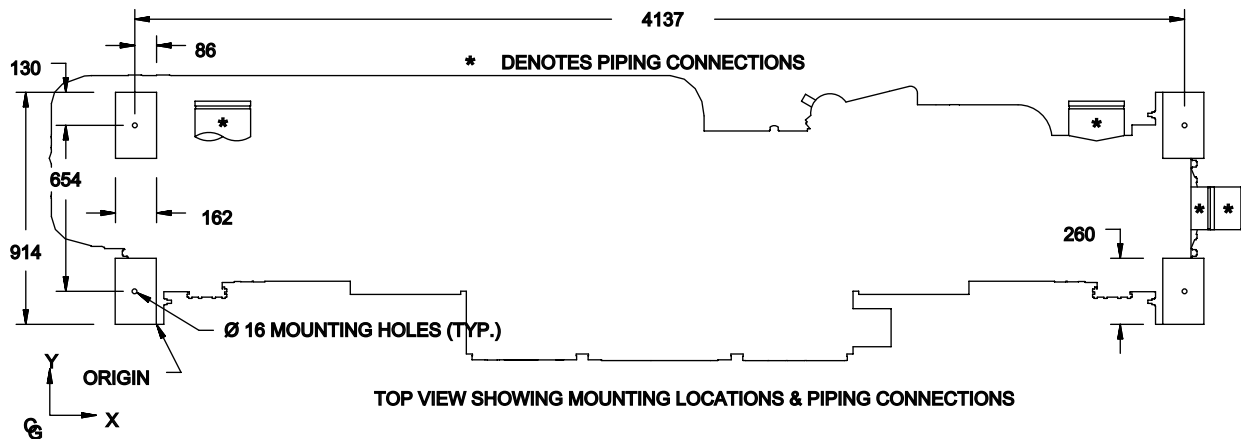

Center of gravity (mm)			
Model	X	Y	Z
YCWS0180SC	2031	613	920

NOTES:

- CLEARANCES - Recommended YORK clearances to service the unit are as follows:
 - Rear to Wall: 508mm
 - Front to Wall: 813mm
 - Top: 508mm
 - Tube cleaning and removal:
 - Models 100, 120, 140 2743mm (either end) for models YCWS0100 thru YCWS0140
 - Models 180 - 240 3962mm (either end) for models YCWS0180 thru YCWS0240
- Shipping skids (not shown) will increase the height of the unit by 152mm, but MUST be removed upon installation.
- Spring and neoprene isolators will increase the overall height of the unit by approximately 76mm.
- Sismic Isolators will increase the overall height of the unit by approximately 241 mm.
- To install 25mm spring isolators, the feet/brackets in the unit should be flipped over 180 degrees, so the isolators fit inside the "house".

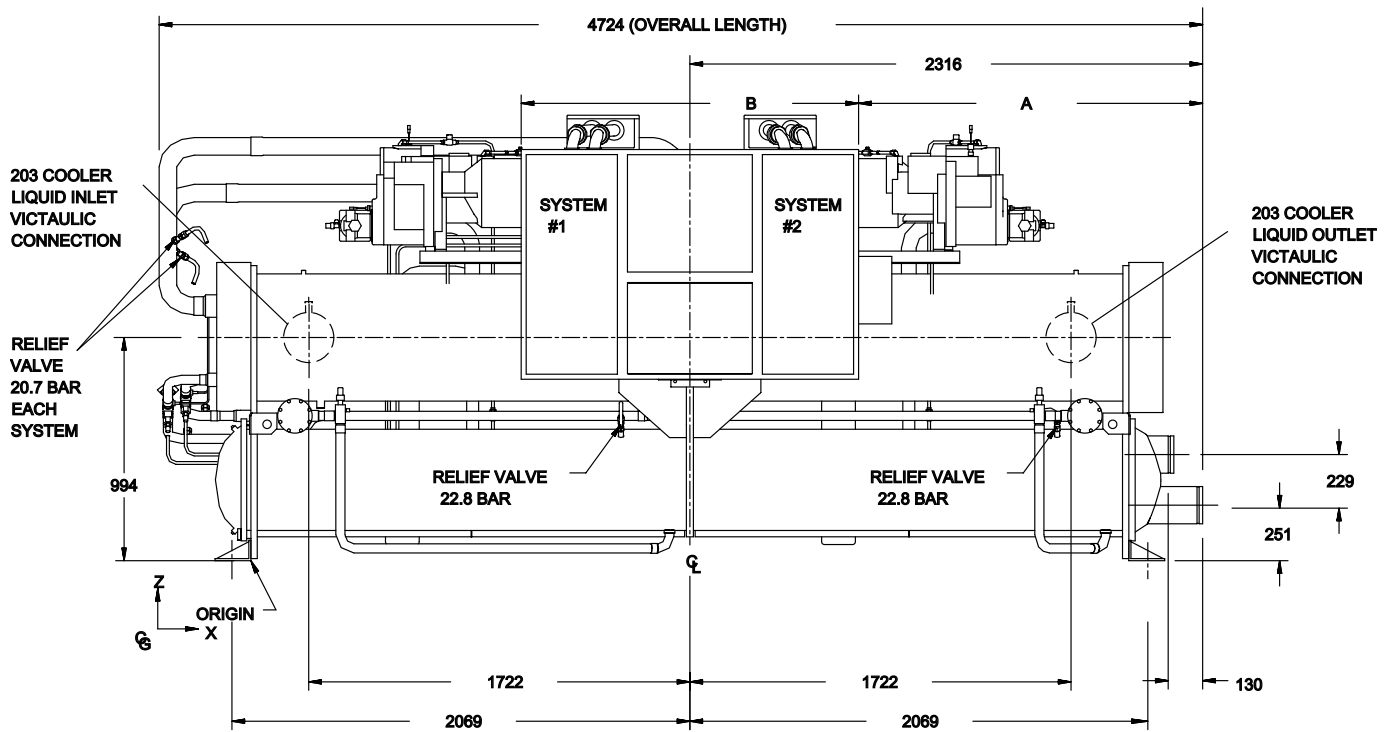

Ref	200/230-3-60	All Other Voltages
A	1422	1556
B	1791	1524
C	1219	1038
D	2146	2010

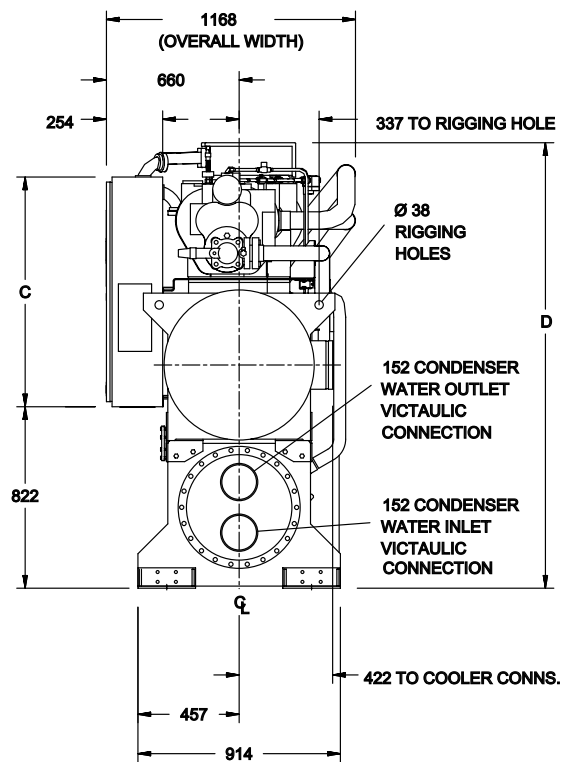

Dimensions - YCWS0200 - SI

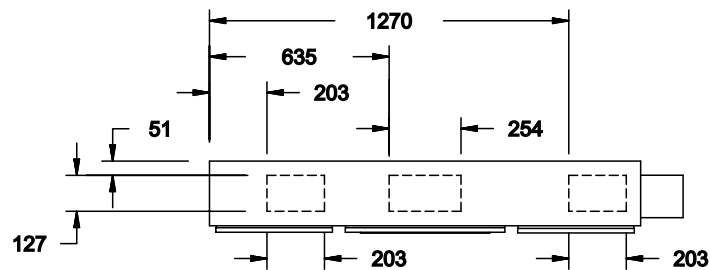
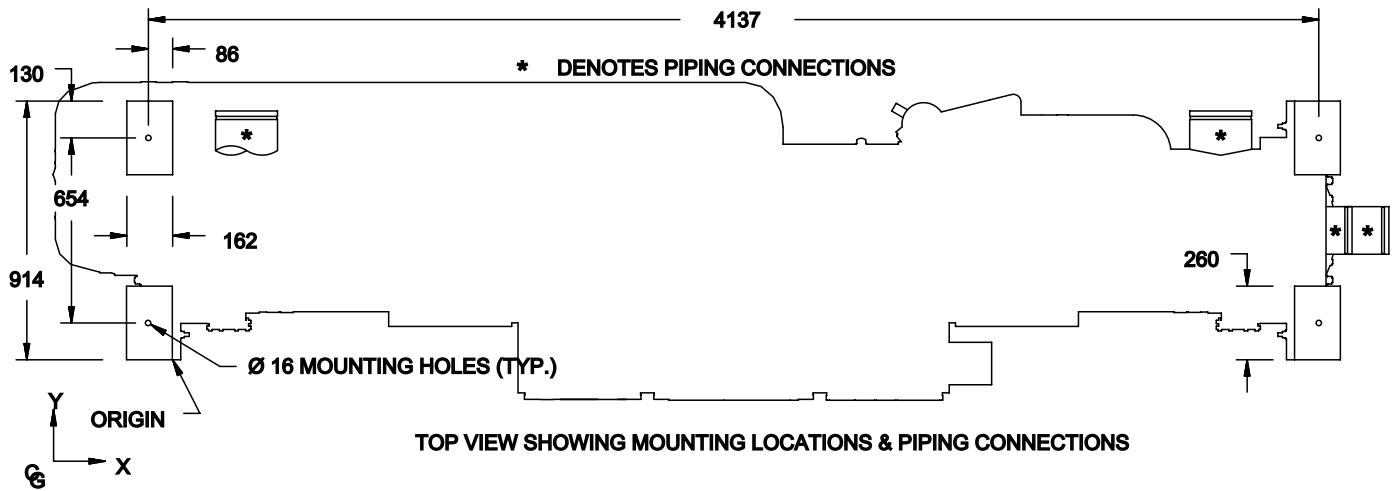

Center of gravity (mm)			
Model	X	Y	Z
YCWS0200SC	2026	612	925

NOTES:

- CLEARANCES** - Recommended YORK clearances to service the unit are as follows:
 Rear to Wall: 508mm
 Front to Wall: 813mm
 Top: 508mm
 Tube cleaning and removal:
 Models 100, 120, 140 2743mm (either end) for models YCWS0100 thru YCWS0140
 Models 180 - 240 3962mm (either end) for models YCWS0180 thru YCWS0240
- Shipping skids (not shown) will increase the height of the unit by 152mm, but **MUST** be removed upon installation.
- Spring and neoprene isolators will increase the overall height of the unit by approximately 76mm.
- Sismic Isolators will increase the overall height of the unit by approximately 241 mm.
- To install 25mm spring isolators, the feet/brackets in the unit should be flipped over 180 degrees, so the isolators fit inside the "house".

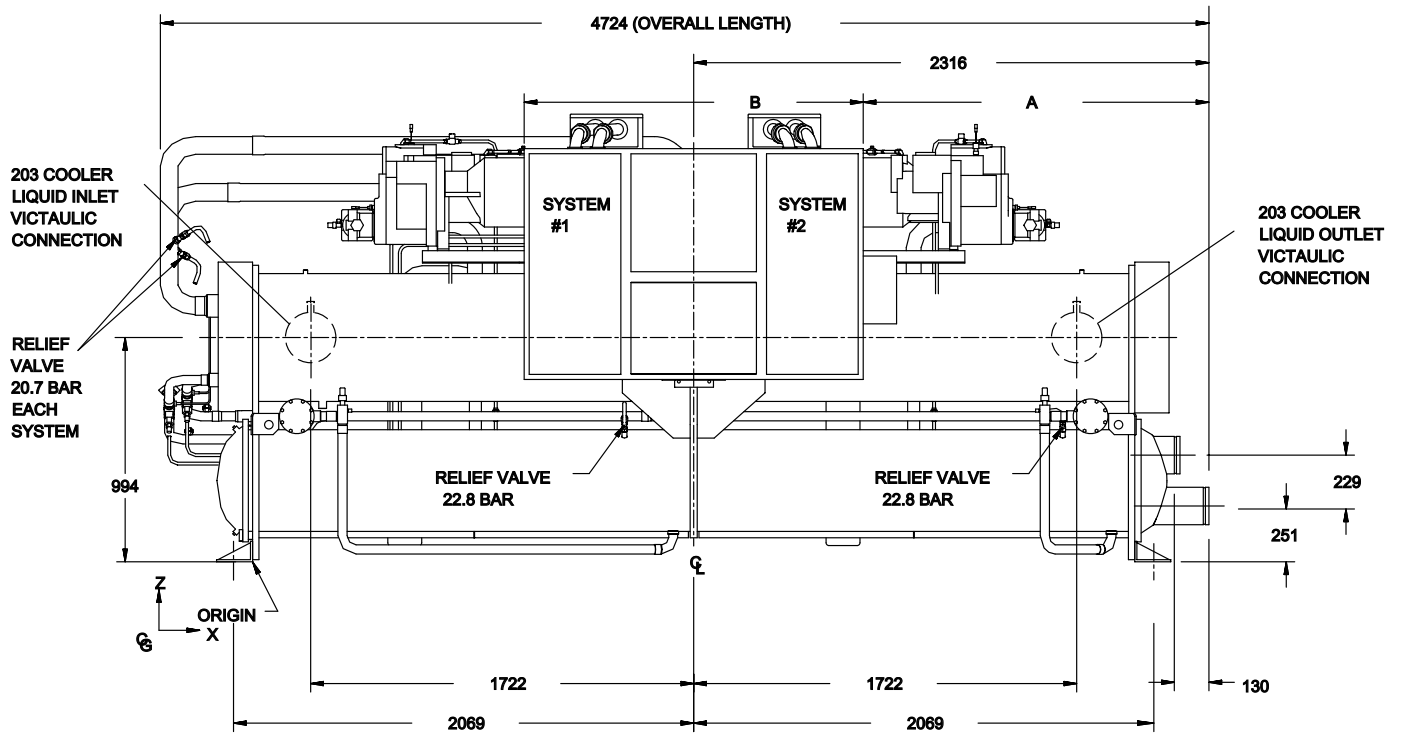

Ref	200/230-3-60	All Other Voltages
A	1422	1556
B	1791	1524
C	1219	1038
D	2146	2010

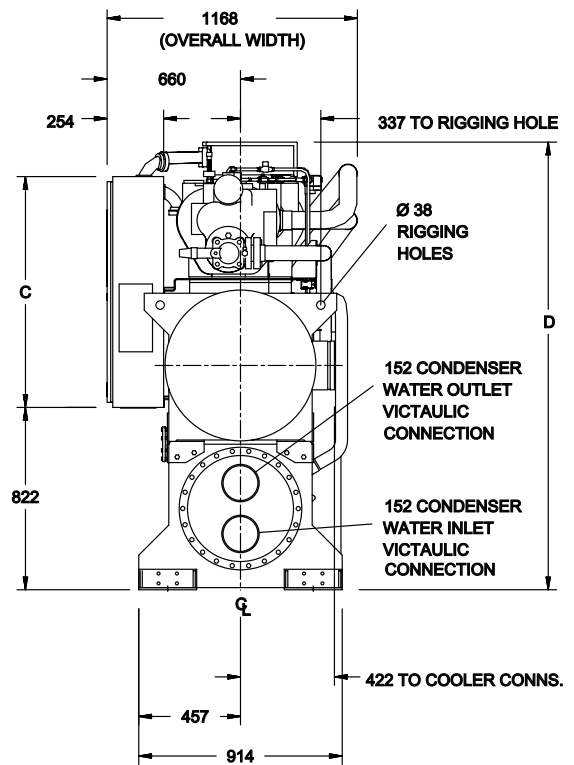

Dimensions - YCWS0220 - SI

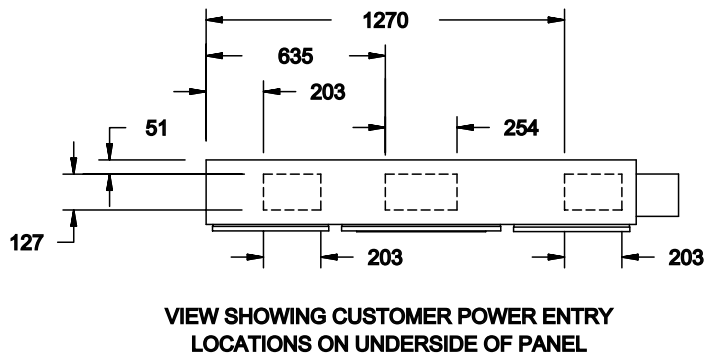
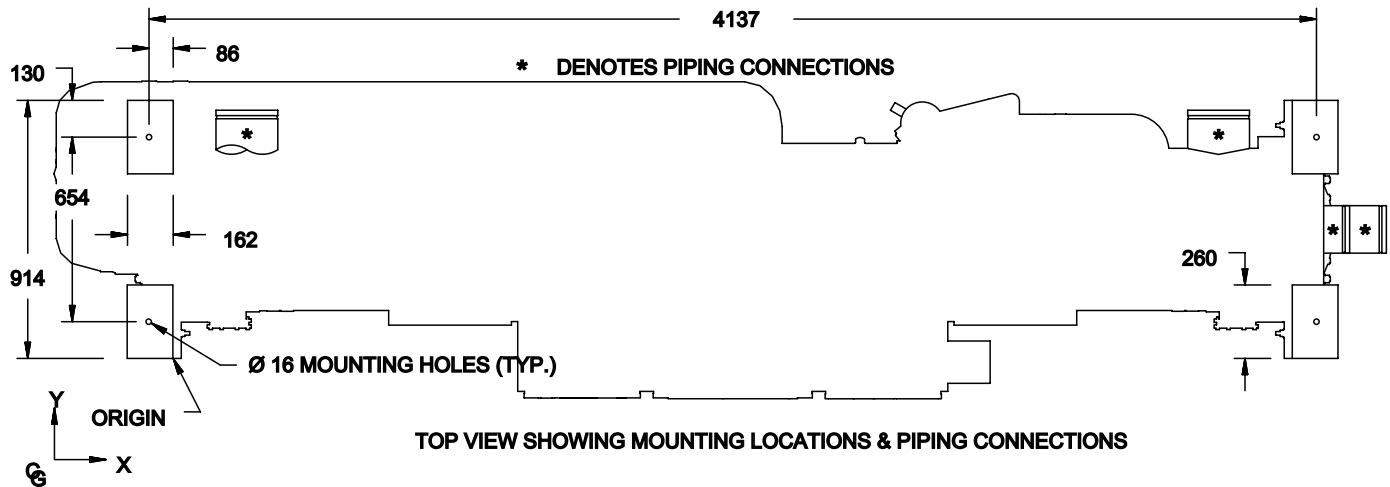

Center of gravity (mm)			
Model	X	Y	Z
YCWS0220SC	2034	611	928

NOTES:

- CLEARANCES - Recommended YORK clearances to service the unit are as follows:
 - Rear to Wall: 508mm
 - Front to Wall: 813mm
 - Top: 508mm
 - Tube cleaning and removal:
 - Models 100, 120, 140 2743mm (either end) for models YCWS0100 thru YCWS0140
 - Models 180 - 240 3962mm (either end) for models YCWS0180 thru YCWS0240
- Shipping skids (not shown) will increase the height of the unit by 152mm, but MUST be removed upon installation.
- Spring and neoprene isolators will increase the overall height of the unit by approximately 76mm.
- Sesmic Isolators will increase the overall height of the unit by approximately 241 mm.
- To install 25mm spring isolators, the feet/brackets in the unit should be flipped over 180 degrees, so the isolators fit inside the "house".

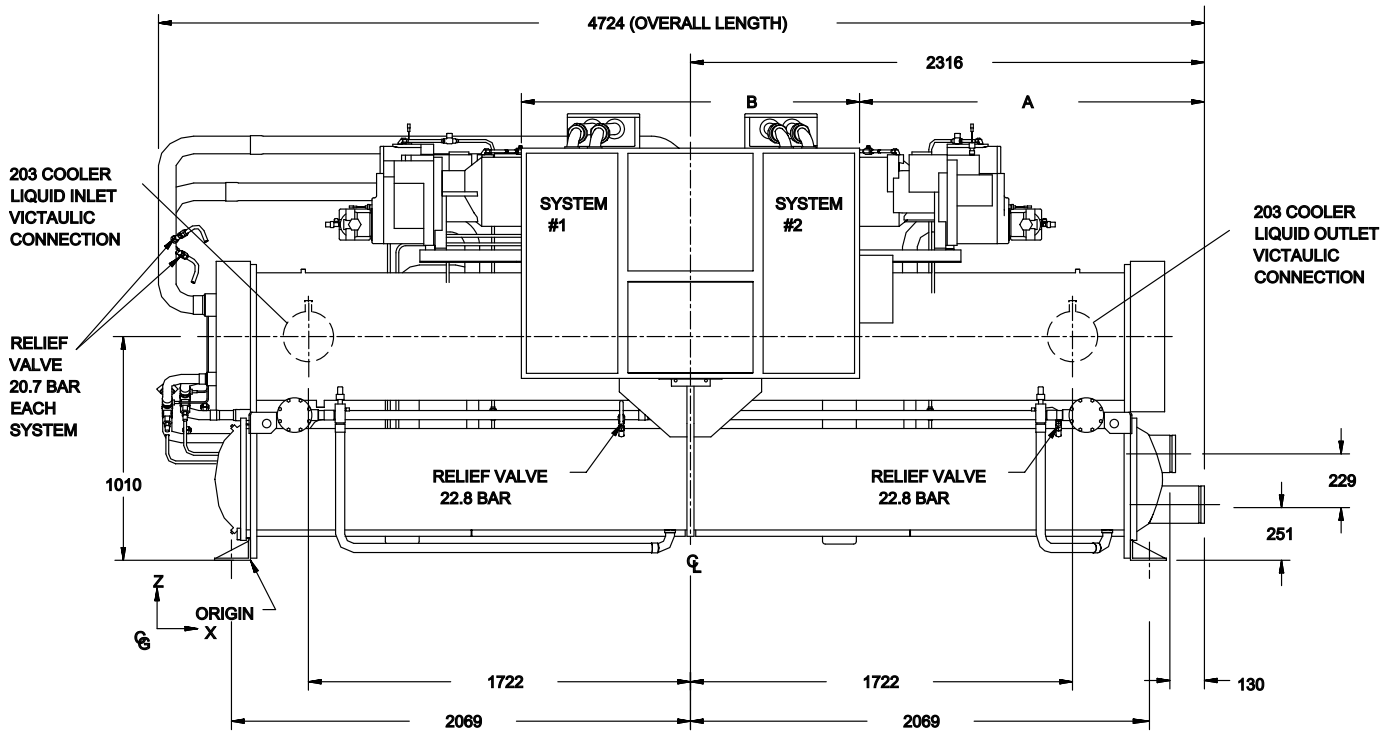

Ref	200/230-3-60	All Other Voltages
A	1422	1556
B	1791	1524
C	1219	1038
D	2146	2010

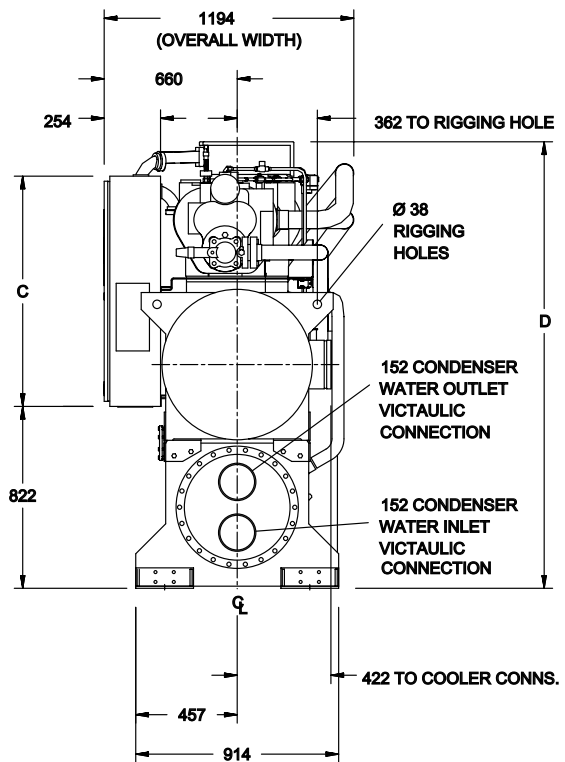

Dimensions - YCWS0240 - SI

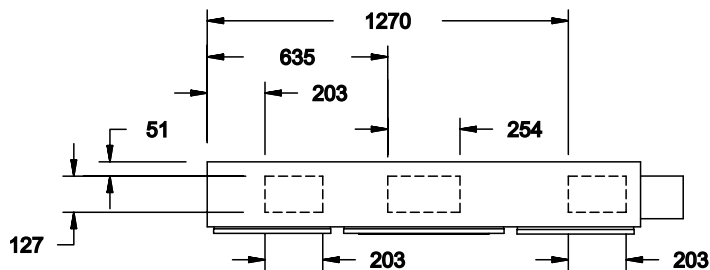
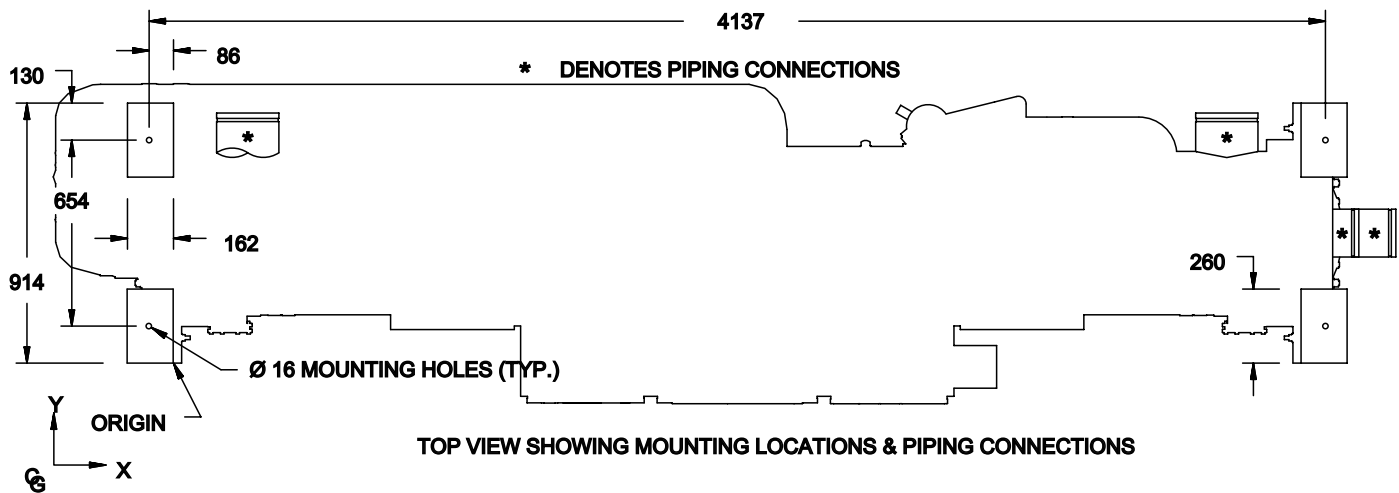

Center of gravity (mm)			
Model	X	Y	Z
YCWS0240SC	2029	610	932

NOTES:

- CLEARANCES - Recommended YORK clearances to service the unit are as follows:

Rear to Wall:	508mm
Front to Wall:	813mm
Top:	508mm

 Tube cleaning and removal:

Models 100, 120, 140	2743mm (either end) for models YCWS0100 thru YCWS0140
Models 180 - 240	3962mm (either end) for models YCWS0180 thru YCWS0240
- Shipping skids (not shown) will increase the height of the unit by 152mm, but MUST be removed upon installation.
- Spring and neoprene isolators will increase the overall height of the unit by approximately 76mm.
- Sismic Isolators will increase the overall height of the unit by approximately 241 mm.
- To install 25mm spring isolators, the feet/brackets in the unit should be flipped over 180 degrees, so the isolators fit inside the "house".

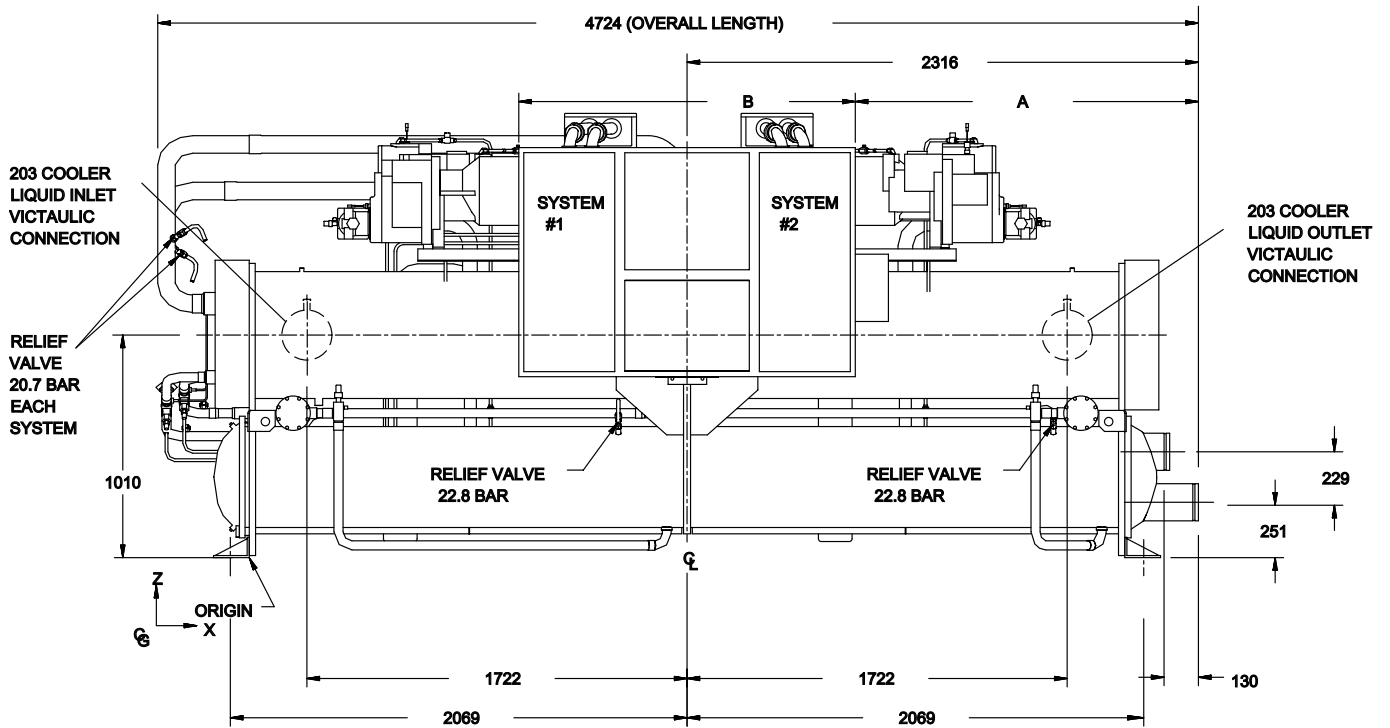

Ref	200/230-3-60	All Other Voltages
A	1422	1556
B	1791	1524
C	1219	1038
D	2146	2010

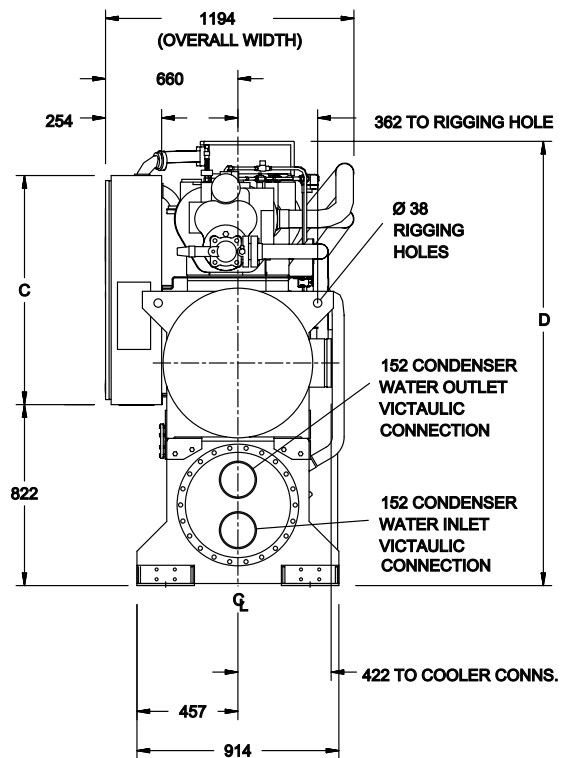

Electrical Data

MULTIPOINT POWER SUPPLY (SEE FIG 10 , PAGE 70)

(Each of the two field provided power supply circuits individually protected with branch circuit protection. Field connections to factory provided Terminal Block(std), Non-Fused Disconnects(opt) or individual system Circuit Breakers(opt) in each of the two motor control centers.)

SYSTEM #1

CHILLER MODEL	VOLT CODE	TERM BLK	TERMINAL BLK CUSTOMER GROUND	N-F DIS SW	N-F DIS SW CUSTOMER GROUND	CKT.BRKR	CKT.BRKR CUSTOMER GROUND-
YCWS0100SC	-17	#2 - 300 KCM	# 6 - 1/0 AWG	#4 - 300 KCM	# 6 - 1/0 AWG	#6 - 350 KCM	# 6 - 1/0 AWG
YCWS0120SC		#1/0 - 300 KCM	# 6 - 1/0 AWG	#4 - 300 KCM	# 6 - 1/0 AWG	#6 - 350 KCM	# 6 - 1/0 AWG
YCWS0140SC		#2/0 - 500 KCM	# 4 - 3/0 AWG	#6 - 350 KCM	# 6 - 1/0 AWG	250 - 500 KCM	# 4 - 3/0 AWG
YCWS0180SC		#2/0 - 500 KCM	# 4 - 3/0 AWG	250 - 500 KCM	# 4 - 3/0 AWG	250 - 500 KCM	# 4 - 3/0 AWG
YCWS0200SC		#2/0 - 500 KCM	# 4 - 3/0 AWG	250 - 500 KCM	# 2 - 4/0 AWG	250 - 500 KCM	# 4 - 3/0 AWG
YCWS0220SC		(2) #2-4/0 AWG	(2) # 6 - 1/0 AWG	250 - 500 KCM	# 2 - 4/0 AWG	(2)250 - 500 KCM	(2) # 2 - 4/0 AWG
YCWS0240SC		(2) #2-4/0 AWG	(2) # 6 - 1/0 AWG	(2) #3/0-250 KCM	# 2 - 4/0 AWG	(2)250 - 500 KCM	(2) # 2 - 4/0 AWG
YCWS0100SC	-28	#2 - 4/0 AWG	# 8 - 2 AWG	#4 - 300 KCM	# 6 - 1/0 AWG	#4 - 300 KCM	# 6 - 1/0 AWG
YCWS0120SC		#2 - 4/0 AWG	# 8 - 2 AWG	#4 - 300 KCM	# 6 - 1/0 AWG	#4 - 300 KCM	# 6 - 1/0 AWG
YCWS0140SC		#2 - 300 KCM	# 6 - 1/0 AWG	#4 - 300 KCM	# 6 - 1/0 AWG	#4 - 300 KCM	# 4 - 3/0 AWG
YCWS0180SC		#2 - 300 KCM	# 6 - 1/0 AWG	#4 - 300 KCM	# 6 - 1/0 AWG	250 - 500 KCM	# 4 - 3/0 AWG
YCWS0200SC		#2/0 - 500 KCM	# 4 - 3/0 AWG	250 - 500 KCM	# 4 - 3/0 AWG	250 - 500 KCM	# 4 - 3/0 AWG
YCWS0220SC		#2/0 - 500 KCM	# 4 - 3/0 AWG	250 - 500 KCM	# 4 - 3/0 AWG	250 - 500 KCM	# 4 - 3/0 AWG
YCWS0240SC		#2/0 - 500 KCM	# 4 - 3/0 AWG	250 - 500 KCM	# 2 - 4/0 AWG	(2)250 - 500 KCM	(2)# 2 - 4/0 AWG
YCWS0100SC	-40	#6 - 1/0 AWG	# 8 - 2 AWG	#14 - 1/0 AWG	# 8 - 2 AWG	#4 - 300 KCM	# 8 - 2 AWG
YCWS0120SC		#6 - 1/0 AWG	# 8 - 2 AWG	#14 - 1/0 AWG	# 8 - 2 AWG	#4 - 300 KCM	# 8 - 2 AWG
YCWS0140SC		#2 - 4/0 AWG	# 8 - 2 AWG	#4 - 300 KCM	# 8 - 2 AWG	#4 - 300 KCM	# 6 - 1/0 AWG
YCWS0180SC		#2 - 4/0 AWG	# 8 - 2 AWG	#4 - 300 KCM	# 8 - 2 AWG	#4 - 300 KCM	# 6 - 1/0 AWG
YCWS0200SC		#2 - 4/0 AWG	# 8 - 2 AWG	#4 - 300 KCM	# 6 - 1/0 AWG	#4 - 300 KCM	# 6 - 1/0 AWG
YCWS0220SC		#2 - 4/0 AWG	# 8 - 2 AWG	#4 - 300 KCM	# 6 - 1/0 AWG	#4 - 300 KCM	# 6 - 1/0 AWG
YCWS0240SC		#2 - 300 KCM	# 6 - 1/0 AWG	#4 - 300 KCM	# 6 - 1/0 AWG	#6 - 350 KCM	# 6 - 1/0 AWG
YCWS0100SC	-46	#6 - 1/0 AWG	# 8 - 2 AWG	#14 - 1/0 AWG	# 8 - 2 AWG	#2 - 4/0 AWG	# 8 - 2 AWG
YCWS0120SC		#6 - 1/0 AWG	# 8 - 2 AWG	#14 - 1/0 AWG	# 8 - 2 AWG	#2 - 4/0 AWG	# 8 - 2 AWG
YCWS0140SC		#6 - 1/0 AWG	# 8 - 2 AWG	#4 - 300 KCM	# 8 - 2 AWG	#4 - 300 KCM	# 8 - 2 AWG
YCWS0180SC		# 6 - 1/0 AWG	# 8 - 2 AWG	#4 - 300 KCM	# 8 - 2 AWG	#4 - 300 KCM	# 8 - 2 AWG
YCWS0200SC		#2 - 4/0 AWG	# 8 - 2 AWG	#4 - 300 KCM	# 8 - 2 AWG	#4 - 300 KCM	# 6 - 1/0 AWG
YCWS0220SC		#2 - 4/0 AWG	# 8 - 2 AWG	#4 - 300 KCM	# 8 - 2 AWG	#4 - 300 KCM	# 6 - 1/0 AWG
YCWS0240SC		#2 - 4/0 AWG	# 8 - 2 AWG	#4 - 300 KCM	# 6 - 1/0 AWG	#4 - 300 KCM	# 6 - 1/0 AWG
YCWS0100SC	-58	#18 - 2 AWG	# 8 - 2 AWG	#14 - 1/0 AWG	# 8 - 2 AWG	#14 - 1/0 AWG	# 8 - 2 AWG
YCWS0120SC		#18 - 2 AWG	# 8 - 2 AWG	#14 - 1/0 AWG	# 8 - 2 AWG	#14 - 1/0 AWG	# 8 - 2 AWG
YCWS0140SC		#6 - 1/0 AWG	# 8 - 2 AWG	#14 - 1/0 AWG	# 8 - 2 AWG	#2 - 4/0 AWG	# 8 - 2 AWG
YCWS0180SC		#6 - 1/0 AWG	# 8 - 2 AWG	#14 - 1/0 AWG	# 8 - 2 AWG	#2 - 4/0 AWG	# 8 - 2 AWG
YCWS0200SC		#6 - 1/0 AWG	# 8 - 2 AWG	#4 - 300 KCM	# 8 - 2 AWG	#4 - 300 KCM	# 8 - 2 AWG
YCWS0220SC		#6 - 1/0 AWG	# 8 - 2 AWG	#4 - 300 KCM	# 8 - 2 AWG	#4 - 300 KCM	# 8 - 2 AWG
YCWS0240SC		#2 - 4/0 AWG	# 8 - 2 AWG	#4 - 300 KCM	# 8 - 2 AWG	#6 - 350 KCM	# 6 - 1/0 AWG

See pg. 68 for Electrical Notes

SYSTEM #2

CHILLER MODEL	VOLT CODE	TERM BLK	TERMINAL BLK CUSTOMER GROUND	N-F DIS SW	N-F DIS SW CUSTOMER GROUND	CKT.BRKR	CKT.BRKR CUSTOMER GROUND
YCWS0100SC	-17	#2 - 300 KCM	# 6 - 1/0 AWG	#4 - 300 KCM	# 6 - 1/0 AWG	#6 - 350 KCM	# 6 - 1/0 AWG
YCWS0120SC		#2/0 - 500 KCM	# 4 - 3/0 AWG	#6 - 350 KCM	# 6 - 1/0 AWG	250 - 500 KCM	# 4 - 3/0 AWG
YCWS0140SC		#2/0 - 500 KCM	# 4 - 3/0 AWG	#6 - 350 KCM	# 6 - 1/0 AWG	250 - 500 KCM	# 4 - 3/0 AWG
YCWS0180SC		#2/0 - 500 KCM	# 4 - 3/0 AWG	#6 - 350 KCM	# 6 - 1/0 AWG	250 - 500 KCM	# 4 - 3/0 AWG
YCWS0200SC		#2/0 - 500 KCM	# 4 - 3/0 AWG	250 - 500 KCM	# 2 - 4/0 AWG	250 - 500 KCM	# 4 - 3/0 AWG
YCWS0220SC		#2/0 - 500 KCM	# 4 - 3/0 AWG	250 - 500 KCM	# 2 - 4/0 AWG	250 - 500 KCM	# 4 - 3/0 AWG
YCWS0240SC		(2) #2-4/0 AWG	(2) # 6 - 1/0 AWG	(2) #3/0-250 KCM	# 2 - 4/0 AWG	(2)250 - 500 KCM	(2) # 2 - 4/0 AWG
YCWS0100SC	-28	#2 - 4/0 AWG	# 8 - 2 AWG	#4 - 300 KCM	# 6 - 1/0 AWG	#4 - 300 KCM	# 6 - 1/0 AWG
YCWS0120SC		#2 - 300 KCM	# 6 - 1/0 AWG	#4 - 300 KCM	# 6 - 1/0 AWG	#4 - 300 KCM	# 4 - 3/0 AWG
YCWS0140SC		#2 - 300 KCM	# 6 - 1/0 AWG	#4 - 300 KCM	# 6 - 1/0 AWG	#4 - 300 KCM	# 4 - 3/0 AWG
YCWS0180SC		#2/0 - 500 KCM	# 4 - 3/0 AWG	250 - 500 KCM	# 2 - 4/0 AWG	250 - 500 KCM	# 4 - 3/0 AWG
YCWS0200SC		#2/0 - 500 KCM	# 4 - 3/0 AWG	250 - 500 KCM	# 4 - 3/0 AWG	250 - 500 KCM	# 4 - 3/0 AWG
YCWS0220SC		#2/0 - 500 KCM	# 4 - 3/0 AWG	250 - 500 KCM	# 4 - 3/0 AWG	(2)250 - 500 KCM	(2)# 2 - 4/0 AWG
YCWS0240SC		#2/0 - 500 KCM	# 4 - 3/0 AWG	250 - 500 KCM	# 2 - 4/0 AWG	(2)250 - 500 KCM	(2)# 2 - 4/0 AWG
YCWS0100SC	-40	#6 - 1/0 AWG	# 8 - 2 AWG	#14 - 1/0 AWG	# 8 - 2 AWG	#4 - 300 KCM	# 8 - 2 AWG
YCWS0120SC		#2 - 4/0 AWG	# 8 - 2 AWG	#4 - 300 KCM	# 8 - 2 AWG	#4 - 300 KCM	# 6 - 1/0 AWG
YCWS0140SC		#2 - 4/0 AWG	# 8 - 2 AWG	#4 - 300 KCM	# 8 - 2 AWG	#4 - 300 KCM	# 6 - 1/0 AWG
YCWS0180SC		#2 - 4/0 AWG	# 8 - 2 AWG	#4 - 300 KCM	# 6 - 1/0 AWG	#4 - 300 KCM	# 6 - 1/0 AWG
YCWS0200SC		#2 - 4/0 AWG	# 8 - 2 AWG	#4 - 300 KCM	# 6 - 1/0 AWG	#4 - 300 KCM	# 6 - 1/0 AWG
YCWS0220SC		#2 - 4/0 AWG	# 8 - 2 AWG	#4 - 300 KCM	# 6 - 1/0 AWG	#6 - 350 KCM	# 6 - 1/0 AWG
YCWS0240SC		#2 - 300 KCM	# 6 - 1/0 AWG	#4 - 300 KCM	# 6 - 1/0 AWG	#6 - 350 KCM	# 6 - 1/0 AWG
YCWS0100SC	-46	#6 - 1/0 AWG	# 8 - 2 AWG	#14 - 1/0 AWG	# 8 - 2 AWG	#2 - 4/0 AWG	# 8 - 2 AWG
YCWS0120SC		#6 - 1/0 AWG	# 8 - 2 AWG	#4 - 300 KCM	# 8 - 2 AWG	#4 - 300 KCM	# 8 - 2 AWG
YCWS0140SC		#6 - 1/0 AWG	# 8 - 2 AWG	#4 - 300 KCM	# 8 - 2 AWG	#4 - 300 KCM	# 8 - 2 AWG
YCWS0180SC		# 2 - 4/0 AWG	# 8 - 2 AWG	#4 - 300 KCM	# 8 - 2 AWG	#4 - 300 KCM	# 6 - 1/0 AWG
YCWS0200SC		#2 - 4/0 AWG	# 8 - 2 AWG	#4 - 300 KCM	# 8 - 2 AWG	#4 - 300 KCM	# 6 - 1/0 AWG
YCWS0220SC		#2 - 4/0 AWG	# 8 - 2 AWG	#4 - 300 KCM	# 6 - 1/0 AWG	#4 - 300 KCM	# 6 - 1/0 AWG
YCWS0240SC		#2 - 4/0 AWG	# 8 - 2 AWG	#4 - 300 KCM	# 6 - 1/0 AWG	#4 - 300 KCM	# 6 - 1/0 AWG
YCWS0100SC	-58	#18 - 2 AWG	# 8 - 2 AWG	#14 - 1/0 AWG	# 8 - 2 AWG	#14 - 1/0 AWG	# 8 - 2 AWG
YCWS0120SC		#6 - 1/0 AWG	# 8 - 2 AWG	#14 - 1/0 AWG	# 8 - 2 AWG	#2 - 4/0 AWG	# 8 - 2 AWG
YCWS0140SC		#6 - 1/0 AWG	# 8 - 2 AWG	#14 - 1/0 AWG	# 8 - 2 AWG	#2 - 4/0 AWG	# 8 - 2 AWG
YCWS0180SC		#6 - 1/0 AWG	# 8 - 2 AWG	#14 - 1/0 AWG	# 8 - 2 AWG	#4 - 300 KCM	# 8 - 2 AWG
YCWS0200SC		#6 - 1/0 AWG	# 8 - 2 AWG	#4 - 300 KCM	# 8 - 2 AWG	#4 - 300 KCM	# 8 - 2 AWG
YCWS0220SC		#2 - 4/0 AWG	# 8 - 2 AWG	#4 - 300 KCM	# 8 - 2 AWG	#6 - 350 KCM	# 6 - 1/0 AWG
YCWS0240SC		#2 - 4/0 AWG	# 8 - 2 AWG	#4 - 300 KCM	# 8 - 2 AWG	#6 - 350 KCM	# 6 - 1/0 AWG

Electrical Data - Cont.

SINGLE POINT POWER SUPPLY (SEE FIG 11 & 12 , PAGE 70 & 71)

(One field provided power supply circuit to the control panel. Field connections to factory provided Terminal Blocks(opt) or Non-Fused Disconnect(opt). Individual system Circuit Breakers, Non-Fused Disconnects or Class 'J' Fuse/Fuse Blocks in each motor control center.)

SYSTEM # 1 & #2					
MODEL NUMBER	VOLT CODE	TERM BLK	TERM BLK CUST. GROUND	N-F DIS SW	N-F DIS SW CUST. GROUND
YCWS0100SC	-17	#2/0 - 500 KCM	# 4 - 3/0 AWG	250 - 500 KCM	# 4 - 3/0 AWG
YCWS0120SC		(2) #2 - 300 KCM	(2) # 4 - 3/0 AWG	(2) 250 - 500 KCM	(2) # 4 - 3/0 AWG
YCWS0140SC		(2) #2 - 300 KCM	(2) # 4 - 3/0 AWG	(2) 250 - 500 KCM	(2) # 4 - 3/0 AWG
YCWS0180SC		(2) #2/0 - 500 KCM	(2) # 4 - 3/0 AWG	(2) 250 - 500 KCM	(2) # 4 - 3/0 AWG
YCWS0200SC		(2) #2/0 - 500 KCM	(2) # 4 - 3/0 AWG	(2) 250 - 500 KCM	(2) # 2 - 4/0 AWG
YCWS0220SC		(2) #2/0 - 500 KCM	(2) # 4 - 3/0 AWG	(2) 250 - 500 KCM	(2) # 2 - 4/0 AWG
YCWS0240SC		(2) #2/0 - 500 KCM	(2) # 4 - 3/0 AWG	(2) 250 - 500 KCM	(2) # 2 - 4/0 AWG
YCWS0100SC	-28	#2/0 - 500 KCM	# 4 - 3/0 AWG	250 - 500 KCM	# 4 - 3/0 AWG
YCWS0120SC		(2)# 2 - 4/0 AWG	(2) # 6 - 1/0 AWG	(2) #3/0 - 250 KCM	(2)#6 - 1/0 AWG
YCWS0140SC		(2) #2 - 300 KCM	(2) # 4 - 3/0 AWG	(2) 250 - 500 KCM	(2) # 4 - 3/0 AWG
YCWS0180SC		(2) #2 - 300 KCM	(2) # 4 - 3/0 AWG	(2) 250 - 500 KCM	(2) # 4 - 3/0 AWG
YCWS0200SC		(2) #2/0 - 500 KCM	(2) # 4 - 3/0 AWG	(2) 250 - 500 KCM	(2) # 4 - 3/0 AWG
YCWS0220SC		(2) #2/0 - 500 KCM	(2) # 4 - 3/0 AWG	(2) 250 - 500 KCM	(2) # 4 - 3/0 AWG
YCWS0240SC		(2) #2/0 - 500 KCM	(2) # 4 - 3/0 AWG	(2) 250 - 500 KCM	(2) # 2 - 4/0 AWG
YCWS0100SC	-40	#2 - 4/0 AWG	# 8 - 2 AWG	#4 - 300 KCM	# 6 - 1/0 AWG
YCWS0120SC		#2 - 300 KCM	# 6 - 1/0 AWG	#6 - 350 KCM	# 6 - 1/0 AWG
YCWS0140SC		#2/0 - 500 KCM	# 4 - 3/0 AWG	250 - 500 KCM	# 4 - 3/0 AWG
YCWS0180SC		#2/0 - 500 KCM	# 4 - 3/0 AWG	250 - 500 KCM	# 4 - 3/0 AWG
YCWS0200SC		#2/0 - 500 KCM	# 4 - 3/0 AWG	250 - 500 KCM	# 4 - 3/0 AWG
YCWS0220SC		#2/0 - 500 KCM	# 4 - 3/0 AWG	250 - 500 KCM	# 4 - 3/0 AWG
YCWS0240SC		#2/0 - 500 KCM	# 4 - 3/0 AWG	250 - 500 KCM	# 4 - 3/0 AWG
YCWS0100SC	-46	#2 - 4/0 AWG	# 8 - 2 AWG	#4 - 300 KCM	# 6 - 1/0 AWG
YCWS0120SC		#2 - 4/0 AWG	# 8 - 2 AWG	#4 - 300 KCM	# 6 - 1/0 AWG
YCWS0140SC		#2 - 300 KCM	# 6 - 1/0 AWG	#4 - 300 KCM	# 6 - 1/0 AWG
YCWS0180SC		#2 - 300 KCM	# 6 - 1/0 AWG	#6 - 350 KCM	# 6 - 1/0 AWG
YCWS0200SC		#2/0 - 500 KCM	# 4 - 3/0 AWG	250 - 500 KCM	# 4 - 3/0 AWG
YCWS0220SC		#2/0 - 500 KCM	# 4 - 3/0 AWG	250 - 500 KCM	# 4 - 3/0 AWG
YCWS0240SC		#2/0 - 500 KCM	# 4 - 3/0 AWG	250 - 500 KCM	# 4 - 3/0 AWG
YCWS0100SC	-58	#6 - 1/0 AWG	# 8 - 2 AWG	#2 - 4/0 AWG	# 8 - 2 AWG
YCWS0120SC		#2 - 4/0 AWG	# 8 - 2 AWG	#6 - 350 KCM	#6 - 1/0 AWG
YCWS0140SC		#2 - 4/0 AWG	# 8 - 2 AWG	#6 - 350 KCM	#6 - 1/0 AWG
YCWS0180SC		#2 - 4/0 AWG	# 8 - 2 AWG	#6 - 350 KCM	#6 - 1/0 AWG
YCWS0200SC		#2 - 300 KCM	# 6 - 1/0 AWG	#6 - 350 KCM	#6 - 1/0 AWG
YCWS0220SC		#2 - 300 KCM	# 6 - 1/0 AWG	#6 - 350 KCM	#6 - 1/0 AWG
YCWS0240SC		#2 - 300 KCM	# 6 - 1/0 AWG	250 - 500 KCM	#4 - 3/0 AWG

See pg. 68 for Electrical Notes

Electrical Notes

NOTES: (for Electrical Data on pages 64-66)

1. Minimum Circuit Ampacity (MCA) is based on 125% of the rated load amps for the largest motor plus 100% of the rated load amps for all other loads included in the circuit, per N.E.C. Article 430-24. If the optional Factory Mounted Control Transformer is provided, add the following MCA values to the electrical tables for the system providing power to the transformer: -50, add 5 amps;
2. The minimum recommended disconnect switch is based on 115% of the rated load amps for all loads included in the circuit, per N.E.C. Article 440.
3. Minimum fuse size is based upon 150% of the rated load amps for the largest motor plus 100% of the rated load amps for all other loads included in the circuit to avoid nuisance trips at start-up due to lock rotor amps. It is not recommended in applications where brown outs, frequent starting and stopping of the unit, and/or operation at ambient temperatures in excess of 35°C (95°F) is anticipated.
4. Maximum fuse size is based upon 225% of the rated load amps for the largest motor plus 100% of the rated load amps for all other loads included in the circuit, per N.E.C. Article 440-22.
5. Circuit breakers supplied by third party vendors must be certified by local electrical standards. Maximum size is based on 225% of the rated load amps for the largest motor plus 100% of the rated load amps for all other loads included in the circuit.
6. The "INCOMING WIRE RANGE" is the minimum and maximum wire size that can be accommodated by the unit wiring lugs. The (2) preceding the wire range indicates the number of termination points available per phase of the wire range specified. Actual wire size and number of wires per phase must be determined based on the National Electrical Code, using copper connectors only. Field wiring must also comply with local codes.
7. A ground lug is provided for each compressor system to accommodate a field grounding conductor per N.E.C. Table 250-95. A control circuit grounding lug is also supplied.
8. The supplied disconnect is a "Disconnecting Means" as defined in the N.E.C. 100, and is intended for isolating the unit for the available power supply to perform maintenance and troubleshooting. This disconnect is not intended to be a Load Break Device.
9. Field Wiring by others which complies to the National Electrical Code & Local Codes.

INTENTIONALLY LEFT BLANK

Customer Wiring Data

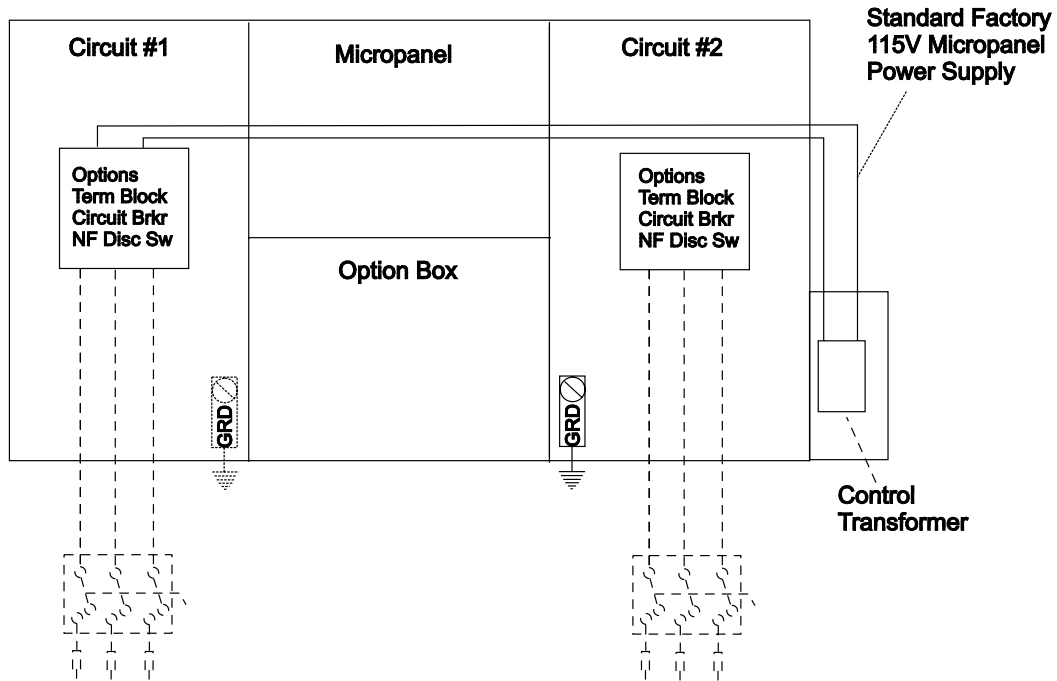

FIGURE 10 - MULTIPOINT POWER SUPPLY CONNECTION - STANDARD UNIT

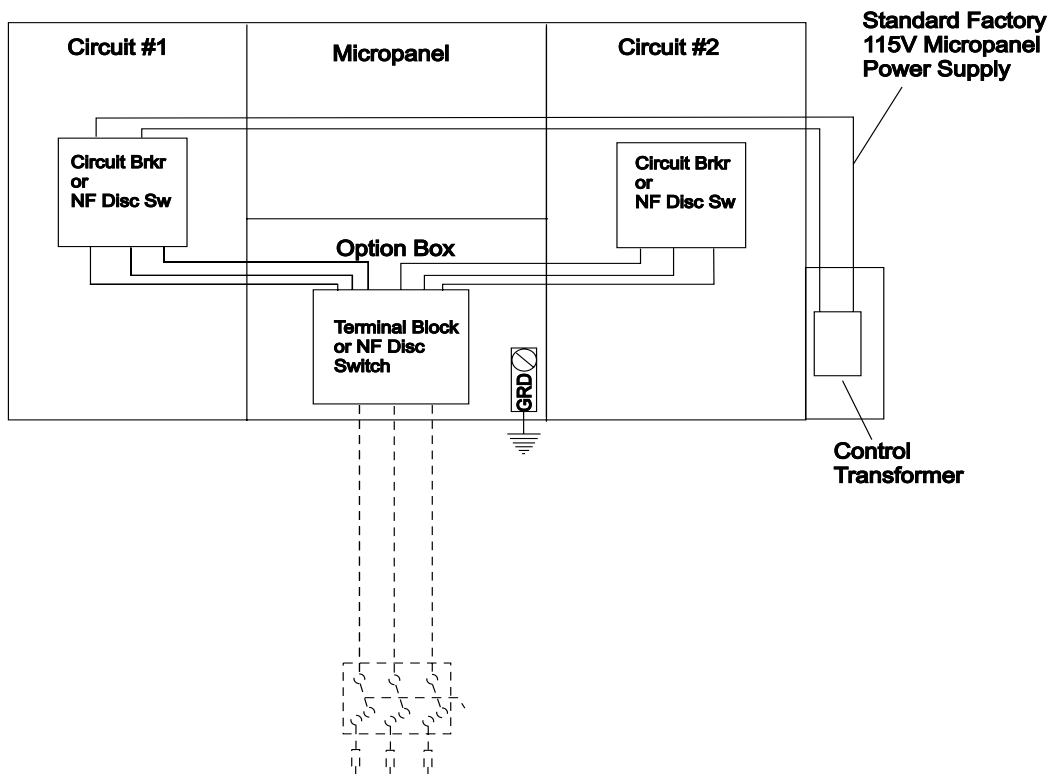

FIGURE 11 - SINGLE POINT POWER SUPPLY WITH INTERNAL CIRCUIT BREAKER OR NON-FUSED DISCONNECT SWITCH

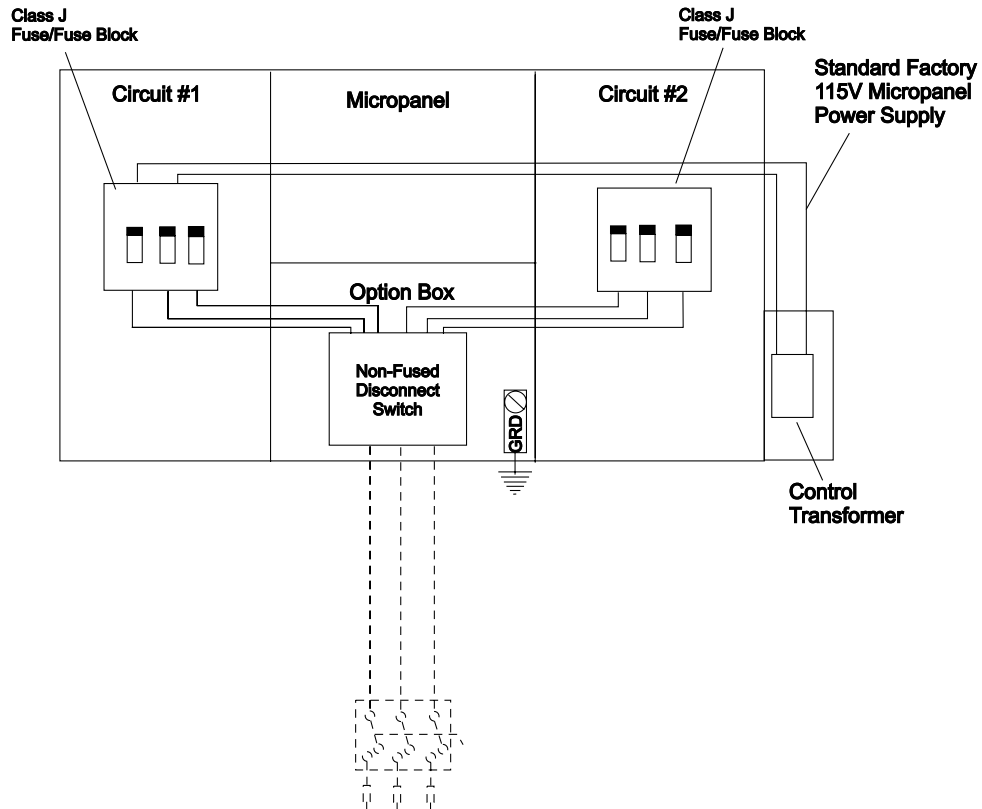

FIGURE 12 - OPTIONAL SINGLE POINT POWER SUPPLY WITH INTERNAL CLASS J FUSES/BLOCK

Notes:

1. Dashed line indicates field provided wiring
2. The above recommendations are based upon the National Electric Code and the use of copper connectors only.
Field wiring must comply with local codes.
3. Single point Non-Fused Disconnect Switch is not offered with additional separate Non-Fused Disconnect Switches

LEGEND

TERM BLOCK	TERMINAL BLOCK (FACTORY MOUNTED)
C.B.	CIRCUIT BREAKER (FACTORY MOUNTED)
NF DISC SW	NON-FUSED DISCONNECT SWITCH (FACTORY MOUNTED)
D.F.	DUAL FUSE
DISC	SW DISCONNECT SWITCH
HZ	HERTZ
MAX	MAXIMUM
MCA	MINIMUM CIRCUIT AMPACITY
MIN	MINIMUM
MIN	NF MINIMUM NON FUSED
RLA	RATED LOAD AMPS
Y-D LRA	YWE-DELTA INRUSH LOCKED ROTOR AMPS

VOLTAGE CODE

- 17 = 200-3-60
- 28 = 230-3-60
- 40 = 380-3-60
- 46 = 460-3-60
- 58 = 575-3-60

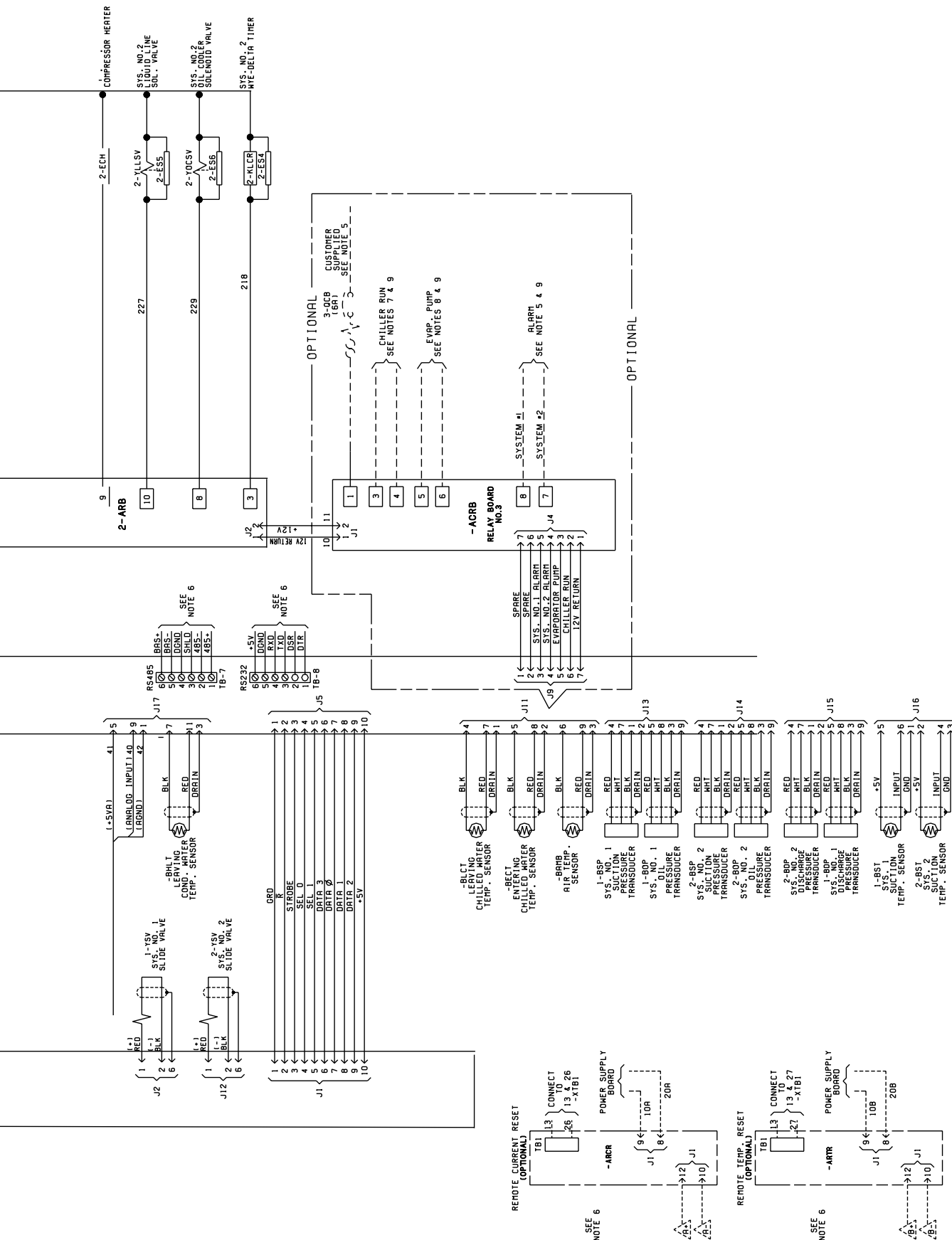

Application Data

UNIT LOCATION

Chillers may be placed on the ground floor or upper floor of the building. The floor must be level and capable of supporting 150% of the operating weight of the unit. Units should be located away from noise-critical areas. Service clearance must be allowed and include space for removing cooler or condenser tubes. A doorway or window can sometimes provide space for tube removal. Units should be installed indoors where they are not exposed to rain or water splash. Chillers should be located near a drain. The use of chillers in corrosive, dusty or explosive atmospheres should be avoided unless the unit is properly protected. A unit located in a clean room will run best, require least maintenance, and last longest. Heat or ventilation may be required to maintain the ambient between 4.4°C and 46.1°C (40°F and 115°F).

UNIT ISOLATION

The chiller foundation must be rigid to reduce vibration transmission to a minimum. All upper story installations should use vibration isolators under the unit base. To maintain isolator efficiency, no mechanical ties should be made to the building. Properly selected flexible connectors and piping isolators are recommended. All the above recommendations will help to reduce vibration transmission and result in a quieter operation.

FIELD CONNECTED WATER PIPING

Piping must comply in all respects with applicable local plumbing codes and ordinances. In no case should the unit support the weight of connecting piping. Since elbows, tees, and valves increase pressure drop, all piping should be kept as simple as possible. Hand stop valves should be installed where required to facilitate servicing. Piping to the inlet and outlet connections of the cooler and condenser may include high-pressure rubber hose or piping loops to ensure against water pump transmission of vibration.

Facilities should be provided for measuring temperature and pressure in the cooler and condenser field water piping. Drain connections should be provided at all low points to permit complete drainage of the cooler(s), condenser(s), and system piping. This is especially important if the unit is located in an unheated room where freezing could prevail. Water lines subjected to ambient temperatures below freezing may require heater cables or antifreeze (by others).

Water loops should contain provisions for venting. A strainer, preferably 40 mesh, should be installed in the cooler and condenser inlet lines, and located where it will protect the circulating pump and the heat exchanger tube bundles. It should be determined that the maximum water pressure at the cooler or condenser does not exceed

the maximum design working pressure of the cooler or condenser.

The water circulating pumps should be located on the inlet side of the heat exchangers. If, however, space does not permit this, the pumps may be located in the outlet water piping. The net positive suction head must be considered when applying pumps.

PARALLEL CHILLER APPLICATION

Multiple chillers are often used to provide increased reliability, reserve capacity, or to divide the design capacity. The standard factory packaged chiller is most compatible with parallel chilled liquid flow. Series flow arrangements are less desirable for pre-engineered packaged units due to excessive chilled liquid flow rate and higher pressure drops. YORK recommends that standard package chillers be arranged for parallel chilled liquid flow.

FIELD WIRING

All field wiring must comply with the National Electric Code and all applicable local codes. YORK liquid chiller units are factory wired for optimum reliability. Therefore the unit controls must not be modified without expressed written consent by YORK. The use of a simple switch or timer from a remote point is permitted; but it must be connected to the YORK unit panel at points expressly indicated for that purpose.

Guide Specifications

YORK Model YCWS _____ Packaged Chiller(s). The (each) unit shall have a cooling capacity of _____ tons with Compressor kW when cooling GPM of water from _____ °C (°F) to _____ °C (°F) and with _____ GPM of condensing water entering at _____ °C (°F) and leaving at _____ °C (°F), and a cooler fouling factor of _____ and condenser water fouling factor of _____. The water pressure drop shall not exceed _____ feet (kPa) of water through the cooler and _____ kPa (feet) of water through the condenser. The unit overall dimensions shall not exceed _____ mm (feet) _____ ins. in length, _____ mm (feet) _____ ins. in width and _____ mm (feet) _____ in height. The unit operating weight shall not exceed _____ Kg (lbs.).

GENERAL

The (Each) Packaged Water Cooled Screw Chiller shall be completely factory assembled (in an ISO 9001 registered facility) including all interconnecting refrigerant piping and internal wiring of controls, mounted on a steel base which accommodates the condenser, compressor(s) and evaporator. Operating test shall include operation with water flowing through the evaporator.

Unit shall be painted with Caribbean Blue enamel. The unit shall be shipped with a full operating charge of R-22. The unit shall contain two separate refrigerant circuits, each with a single compressor for standby operation. All units shall be designed and constructed in accordance with the applicable sections of the following: American Society of Heating, Refrigeration and Air Conditioning Engineers ANSI/ASHRAE 15 Safety Code for Mechanical Refrigeration; American Society of Mechanical Engineers ASME Pressure Vessel Code; National Electrical Code/National Fire Protection Association NFPA 70. The unit shall be produced at an ISO 9001 registered facility. All chillers are rated in accordance with ARI Standard 550/590.

COMPRESSORS

Compressors shall be direct drive, semi-hermetic, rotary twin-screw type, including: internal muffler, temperature actuated, off-cycle heater, terminal box, internal discharge check, discharge and suction shutoff service valves, and precision machined cast iron housing. Design working pressure of entire compressor, suction to discharge, shall be 31 bar (450psig).

Motors shall feature refrigerant suction-gas cooled two-pole accessible hermetic compressor motor, full suction gas flow through a mesh screen, with inherent internal thermal overload protection and external current overload on all three phases. Motor stator shall employ

APT2000 type magnet wire.

Lubrication shall feature external oil separators with no moving or fragile parts, 31 bar (450psig) design working pressure, and UL listing. Refrigerant system differential pressure shall provide oil flow through service replaceable, 0.5 micron, full flow, cartridge type oil filter internal to compressor. Filter bypass, less restrictive media, or oil pump not acceptable.

Compressors shall start at minimum load position. Capacity control range from 100% to 10% of chiller full load using continuous function slide valves, and without hot gas bypass. Step unloading unacceptable. Provide Microprocessor controlled, output pressure regulating capacity control valve to command compressor capacity independent of control valve input pressure and balance compressor capacity with cooling load.

CAPACITY CONTROL SYSTEM

Continuous function, microprocessor controlled, 3- way proportional Capacity Control Valve provides regulated output pressure independent of valve input pressure for a stable, smooth, and precise match of compressor capacity to cooling load to 10% of chiller capacity.

COOLER

The cooler shall be a direct expansion shell and tube type with refrigerant in the tubes and liquid to be chilled in the shell. The design working pressure of the cooler shell (liquid) side shall be 150 PSIG for the tube (refrigerant) side. Refrigerant heads shall be removable. The cooler shall be covered with 3/4" flexible closed cell foam insulation (K = 0.25 maximum) to prevent sweating. The cooler shall be constructed and tested in accordance with ASME Code requirements. Vent and drain connections shall be included. The water connections shall be fully accessible and grooved to accept victaulic couplings if used (by others).

CONDENSER

The condenser is a cleanable thru-tube with steel shell, copper tubes, removable water heads and includes integral subcooling. Refer to PHYSICAL DATA for design working pressures. The shell will be constructed and tested in accordance with section VIII, division 1 of ASME pressure-vessel code. The condenser is equipped with relief valves and will hold the full refrigerant charge for pumpdown.

Guide Specifications - Cont.

each unit. All piping will be ACR copper with brazed joints. The liquid line will include: a shutoff valve with charging port; sightglass with moisture indicator; thermal expansion valve; solenoid valve; and high-absorption removable-core filter drier. The entire suction line and the liquid line between the expansion valve and the cooler will be insulated with flexible, closed-cell, foam insulation.

MICROCOMPUTER CONTROL CENTER

Each unit shall contain a Microcomputer Control Center. All logic and controls shall be contained within a IP 32 (NEMA 1) cabinet with hinged outer door with positive acting latches. Inside shall be contained the "user friendly" and interactive inputs and outputs as follows: LCD display with light emitting diode back lighting for easy viewing of data and input buttons for DISPLAY (temperatures, pressure, etc.), ENTRY (enter/cancel inputs, advance day, change AM/PM), SETPOINTS (change), CLOCK (set time and schedule), PRINT (calling up operating and shutdown data), PROGRAM (change inputs from special conditions such as brine chilling) and UNIT ON/OFF.

The Microcomputer Control Center shall be capable of displaying the following: return and leaving liquid temperature; return and leaving condenser water temperature (optional); low leaving liquid temperature cutout setting; system 1 and 2 percent full-load motor current and suction, discharge (optional) and oil differential pressures;

liquid pulldown control range (selectable for 0.6°C to 1.1° C [1°F to 2°F] in one-tenth increments above the setpoint); liquid pull-down rate sensitivity (0.3°C to 3.0°C [0.5°F to 5°F]/minute in 0.05°C [0.1°F] increments); anti-

recycle timer status; compressor run status; no cooling load condition; day; date; time; out of range message; daily and holiday scheduling of start/stop times; automatic or manual lead/lag status; lead compressor definition; number of compressor starts and running hours; status of hot gas bypass valves (option), liquid line solenoid valves, and water pump; last three fault shutdowns data; number of unloading steps; compressor load and unload timer status.

The operating program shall be stored in nonvolatile memory (EPROM) to eliminate chiller failure due to AC power failure/battery discharge. Programmed setpoints are retained in lithium battery – backed RTC memory for 5 years minimum.

Provisions shall be included for: pumpdown at shutdown and recycling pumpdown; a hard copy printout from a printer (by others) via an RS-232 electrical output; two steps of demand load limiting and remote chilled liquid reset from an external building automation system; unit alarm contacts; chilled water pump or remote air-cooled condenser control; or Remote Control with printout capability (up to 2000 feet) via an RS-485 electrical output.

POWER PANEL

The power panel shall contain the compressor power terminals. U.L. recognized compressor motor starting contactors which meet I.E.C. requirements, current transformer sensing for each compressor power source, for protection against under current, over current, imbalanced current, single phasing compressor stall and voltage spikes, and control power supply terminal strip for 115-1-50/60 with fuse protection.

