



# AIR-COOLED SCREW LIQUID CHILLERS

RENEWAL PARTS

Supersedes: 201.21-RP1 (114)

Form 201.21-RP1 (616)

## MODELS YCAV0157, 0177, 0187, 0197, 0207, 0227, 0247 AND YCAV0267 STYLE "A"



200-3-60  
230-3-60  
315-3-60  
460-3-60  
380/415-3-50  
575-3-60  
MODELS ONLY

150 - 260 TON  
527 - 914Kw  
R-134a  
50 Hz & 60Hz

Issue Date:  
June 30, 2016



## CHANGEABILITY OF THIS DOCUMENT

In complying with YORK's policy for continuous improvement, the information contained in this document is subjected to change without notice. While YORK makes no commitment to update or provide current information automatically to the manual user, that information, if applicable, can be obtained by contacting the nearest YORK Engineered Systems Service office.

It is the responsibility of operating/service personnel as to the applicability of these documents to the equipment in question. If there is any question in the mind of operating/ service personnel as to the applicability of these documents, then, prior to working on the equipment, they should verify with the owner, whether the equipment has been modified and if the current literature is available.

---

### **WARNING**

#### **HIGH VOLTAGE**

**Is used in the operation of this equipment.**

#### **DEATH OR SERIOUS INJURY**

**may result if personnel fail to observe safety precautions.**

Work on electronic equipment should not be undertaken unless the individual(s) have been trained in the proper maintenance of equipment and is (are) familiar with its potential hazards.

Shut off power supply to the equipment before beginning work and follow lockout procedures. When working inside equipment with power off, take care to discharge every capacitor likely to hold dangerous potential.

Be careful not to contact high voltage connections when installing or operating this equipment.

#### **LOW VOLTAGE**

DO NOT be misled by the term "low voltage." Voltages as low as 50 volts may cause death.

## TABLE OF CONTENTS

	<u>PAGE</u>
UNIT NOMENCLATURE NAMEPLATE ENGINEERING DATA .....	4
<b>EVAPORATOR</b>	
EVAPORATOR COMPONENTS .....	6
<b>CONDENSER COILS</b>	
CONDENSER COIL COMPONENTS .....	9
<b>FAN</b>	
FAN COMPONENTS.....	14
<b>PIPING</b>	
REFRIGERANT PIPING COMPONENTS.....	16
GLYCOL LOOP COMPONENTS .....	24
<b>COMPRESSOR</b>	
COMPRESSOR .....	26
<b>VARIABLE SPEED DRIVE</b>	
CONTROL AND VARIABLE SPEED DRIVE PANEL CONFIGURATION.....	28
VARIABLE SPEED DRIVE PANEL COMPONENTS.....	30
VARIABLE SPEED DRIVE POWER ASSEMBLY COMPONENTS .....	44
VARIABLE SPEED DRIVE COOLING FAN ASSEMBLY COMPONENTS .....	46
PLUG AND JUMPER ARRANGEMENT.....	47
SENSOR HARNESSES.....	48
TRANSDUCERS AND TEMP SENSORS .....	55
TRANSDUCER AND THERMISTOR WIRE HARNESS CONNECTORS .....	57
<b>CHILLER OPTIONS</b>	
VIBRATOR ISOLATORS .....	58
YCAV CHILLER OPTIONS - KITS .....	59
ENCLOSURE KIT OPTIONS .....	60
RECOMMENDED SPARE PARTS.....	67

# UNIT NOMENCLATURE NAMEPLATE ENGINEERING DATA

## BASIC PART NUMBER

# YCAV0207EA40VAA

1	2	3	4	5	6	7	8	9	10	11	12	13	14	15
BASE PRODUCT TYPE				NOMINAL CAPACITY				UNIT DESIGNATOR	REFRIGERANT	VOLTAGE/STARTER			DESIGN/DEVELOPMENT LEVEL	
Y	C	A	V	#	#	#	#	S	A	1	7		A	
: YORK : Chiller : Air Cooled V : Screw				Tons/Kw 0157-0513 0177-0563 0187-0633 0197-0673 0207-0703 0227-0733 0247-0813 0267-0883				Standard Standard Optimized High Efficiency High Efficiency Optimized	:R-134a	:200/3/60 :230/3/60 :380/3/60 :460/3/60 :380-415/3/50 :575/3/60 V :Variable Speed Drive			:Design Series A : :Engineering Change or PIN Level	

## PART NUMBER – LETTER CODES

16 17 18 19	20 21 22 23 24 25 26 27 28	29 30 31 32 33 34 35 36 37
POWER FIELD	CONTROLS FIELD	COMPRESSOR / PIPING FIELD
S X : SP TB B X : SP CB S S : SP TB w/ Ind. Sys. NF Disc. Sw. C S : SP CB w/ Ind. Sys. NF Disc. Sw. : : : : T : Control Transformer O : Convenience Outlet	X : No Ambient Kit T : Temp. Reset / Offset C : Current Reset / Offset B : Temp. and Current Reset / Offset M : ISN Microgateway S : Spanish LCD & Keypad Display F : French LCD & Keypad Display G : German LCD & Keypad Display I : Italian LCD & Keypad Display P : Portuguese LCD & Keypad Display N : Silent Night N : N. American Safety Code (c.U.L./c.ETL) N : No Listing (typically 50 HZ non-CE, non-U.L.) : Q : Pump Control O : OptiView Remote Panel S : Sequence Control & Automatic Lead Transfer	# : Low Temp. Brine (LBrT) # : Thermal Storage T : Chicago Relief Code S : Service Isolation Valve C : Both Chicago Relief Code & Isolation Valve B : Service Isolation Valve H : Service Isolation Valve

**MP** = Multiple Point  
**SP** = Single Point  
**NF** = Non-Fused  
**TB** = Terminal Block  
**Ser.** = Service  
**Ind. Sys. Brkr. & L. Ext. Handles** = Individual System Breaker & Lockable External Handle

38 39 40 41 42 43 44	45 46 47	48 49 50 51 52 53 54	55	56	57	61
EVAP. FIELD	CONDENSER FIELD	CABINET FIELD	EXTENDED FIELD WARRANTY	REFRIGERANT WARRANTY	REFRIGERANT WARRANTY	PLANT OF MANUFACTURE
X : :150# PSI DWP 3 : :300# PSI DWP D : :Double Thick Insulation W : :Weld Flange V : :Victaulic Flange S : :Flow Switch D : :Diff. Press. Switch A : :ASME Pressure Vessel and Associated Codes R : :Remote Cooler	X : Aluminum C : Copper B : Black Fin P : Phenolic H : Heat Recovery X : TEAO Fan Motors	1 : Wire (Full Unit) Enc. Panels (factory) 3 : Wire/Louvered Enc. Panels (factory) 5 : Louvered (Cond. Only) Enc. Panels (factory) 7 : Louvered (Full Unit) Enc. Panels (factory) P : Perimeter Sound Blanket B : Acoustic Sound Blanket D : Both Perimeter & Acoustic Sound Blanket L : Low Sound Fans H : High Static Fans 1 : 1" Deflection S : Seismic N : Neoprene Pads	X : 1st Year Parts Only B : 1st Year Parts & Labor C : 2nd Year Parts Only D : 2nd Year Parts & Labor E : 5 Year Compressor Parts Only F : 5 Year Compressor Parts & Labor Only G : 5 Year Units Parts Only H : 5 Year Unit Parts & Labor	X : No Refrigerant Warranty 1 : 1 Year Refrigerant 2 : 2 Year Refrigerant 5 : 5 Year Refrigerant	A : Buy American Act Compliance C : Container Shipping Kit B : Buy American Act Compliance & Container Shipping Kit	R : Monterrey

**NOTES:**  
 1. Q :DENOTES SPECIAL / S.Q.  
 2. # :DENOTES STANDARD  
 3. X :w/in OPTIONS FIELD, DENOTES NO OPTION SELECTED  
 4. Agency Files (i.e. U.L. / ETL; CE; ARI; ETC.) will contain info. based on the first 14 characters only.  
 5. Plant of manufacture to include PIN 61 upon entering the chiller order.

*This page intentionally left blank*

# EVAPORATOR COMPONENTS

**Service Note:**

Pin location 38 in Model Number will be "X" for 150# DWP Cooler.

Pin location 38 in Model Number will be "3" for 300# DWP Cooler.

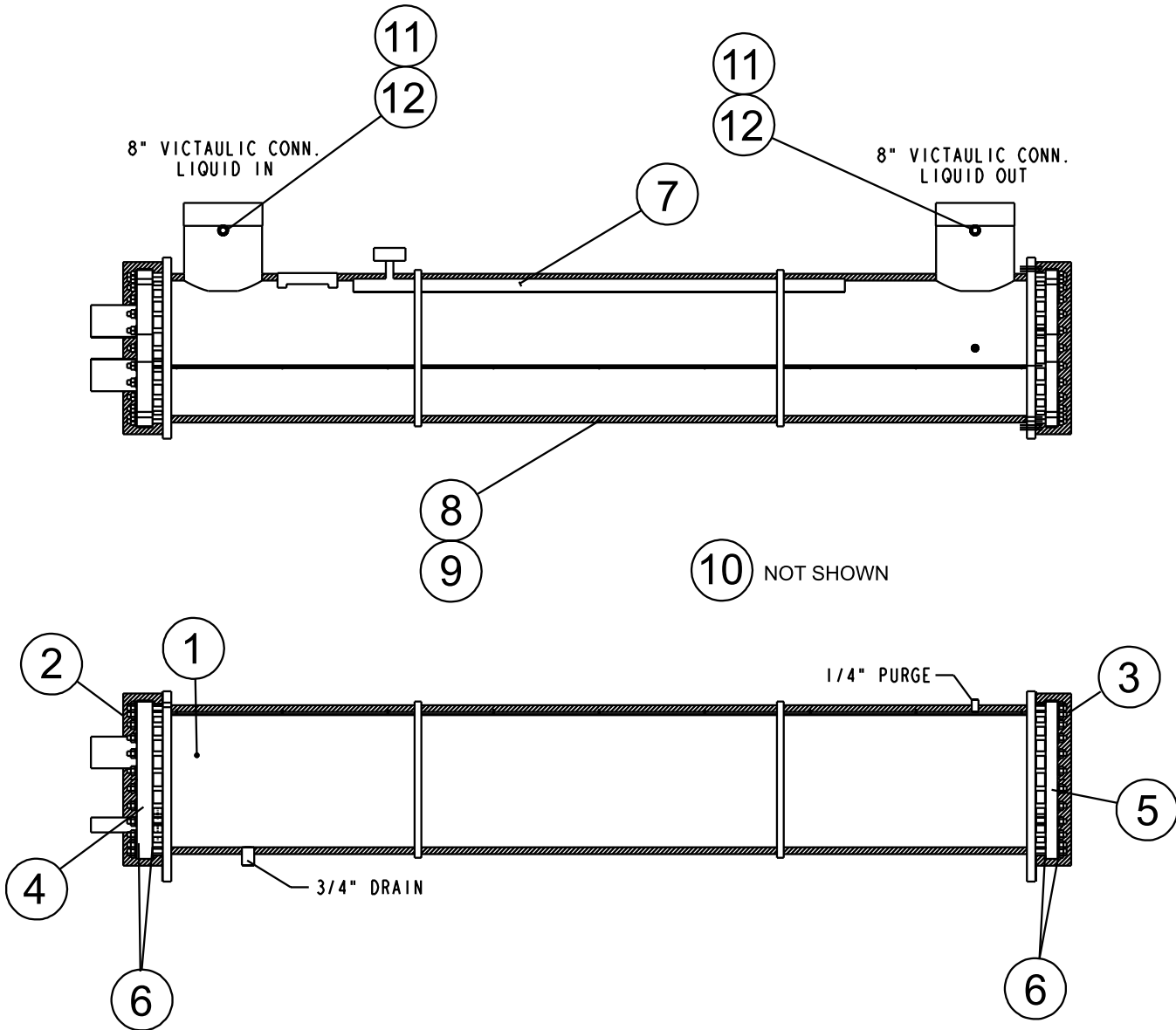

**Service Note:**

Standard 150# DWP Cooler Flow Switch - 024-26116-000

Optional 300# DWP Cooler Flow Switch - 024-12144-000

Differential Pressure Switch - 025-30919-000

**FIG. 1 – EVAPORATOR COMPONENTS (REF. TABLES 1 AND 1A, PAGES 7 AND 8)**

## EVAPORATOR COMPONENTS (CONT'D)

### 150 PSIG

**TABLE 1 – EVAPORATOR COMPONENTS - PIN #9 = 'S OR P' (SEE FIG. 1, PAGE 6)**

ITEM #	QTY PER UNIT	DESCRIPTION	DWP	UNIT MODEL YCAV0157	UNIT MODELS YCAV0177 AND YCAV0187	UNIT MODELS YCAV0207, 0227, 0247 AND YCAV0267
1	1	Evaporator, Fully Insulated with Heater	ALL	375-67299-001	375-65095-001	375-65092-001
		Evaporator, less Heater & Insulation		375-67300-000	375-65096-000	375-65091-000
2	1	Head, Connection End	ALL	075-54517-000	075-54488-000	075-53210-000
3	1	Head, Back End	ALL	075-54515-000	075-54486-000	075-53206-000
4	1	Baffle, Connection End	ALL	075-54519-000	075-54490-000	075-65304-000
5	1	Baffle, Back End	ALL	075-54514-000	075-54485-000	075-5-000
6	2	Gasket, Baffle and Head	ALL	075-54520-000	075-54491-000	075-55103-000
7	2	Heater, Cooler 280 Watt	ALL	025-22691-000	025-22691-000	025-22691-000
8	-	Insulation (3/4"x49"x65")	ALL	010-05997-000	010-05997-000	010-05997-000
9	-	Insulation (1 1/2"x49"x65")		010-05998-000	010-05998-000	010-05998-000
10	1 qt.	Adhesive (Use with #6)	ALL	013-03311-000		
11	2	Sensor, Water Temperature	ALL	025-40334-000	025-40334-000	025-40334-000
12	2	Well, Thermo	ALL	026-33627-000	026-33427-000	026-33427-000

**TABLE 1 (CONT'D) – EVAPORATOR COMPONENTS - PIN #9 = "E" OR "V" (SEE FIG. 1, PAGE 6)**

ITEM #	QTY PER UNIT	DESCRIPTION	DWP	UNIT MODELS YCAV0157, 0177 AND YCAV00187	UNIT MODELS YCAV0197, 0207 AND YCAV0227	UNIT MODEL YCAV0247
1	1	Evaporator, Fully Insulated with Heater	ALL	375-65095-001	375-67303-001	375-65092-001
		Evaporator, less Heater & Insulation		375-65096-000	375-67304-000	375-65091-000
2	1	Head, Connection End	ALL	075-54488-000	075-53794-000	075-54488-000
3	1	Head, Back End	ALL	075-54486-000	075-53796-000	075-54486-000
4	1	Baffle, Connection End	ALL	075-54490-000	075-53790-000	075-54490-000
5	1	Baffle, Back End	ALL	075-54485-000	075-53792-000	075-54485-000
6	2	Gasket, Baffle and Head	ALL	075-54491-000	075-53797-000	075-54491-000
7	2	Heater, Cooler 280 Watt	ALL	025-22691-000	025-22691-000	025-22691-000
8	-	Insulation (3/4"x49"x65")	ALL	010-05997-000	010-05997-000	010-05997-000
9	-	Insulation (1 1/2"x49"x65")		010-05998-000	010-05998-000	010-05998-000
10	1 qt.	Adhesive (Use with #6)	ALL	013-03311-000		
11	2	Sensor, Water Temperature	ALL	025-40334-000	025-40334-000	025-40334-000
12	2	Well, Thermo	ALL	026-33627-000	026-33427-000	026-33427-000

# EVAPORATOR COMPONENTS (CONT'D)

## 300 PSIG

**TABLE 1A – EVAPORATOR COMPONENTS - PIN #9 = 'S OR P' (SEE FIG. 1, PAGE 6)**

ITEM #	QTY PER UNIT	DESCRIPTION	DWP	UNIT MODEL YCAV0157	UNIT MODELS YCAV0177 AND YCAV0187	UNIT MODELS YCAV0207, 0227, 0247 AND YCAV0267
1	1	Evaporator, Fully Insulated with Heater	ALL	375-67315-001	375-67311-001	375-67307-001
		Evaporator, less Heater & Insulation		375-67316-000	375-67312-000	375-67308-000
2	1	Head, Connection End	ALL	075-54517-000	075-54488-000	075-53210-000
3	1	Head, Back End	ALL	075-54515-000	075-54486-000	075-53206-000
4	1	Baffle, Connection End	ALL	075-54519-000	075-54490-000	075-65304-000
5	1	Baffle, Back End	ALL	075-54514-000	075-54485-000	075-5-000
6	2	Gasket, Baffle and Head	ALL	075-54520-000	075-54491-000	075-55103-000
7	2	Heater, Cooler 280 Watt	ALL	025-22691-000	025-22691-000	025-22691-000
8	-	Insulation (3/4"x49"x65")	ALL	010-05997-000	010-05997-000	010-05997-000
9	-	Insulation (1 1/2"x49"x65")		010-05998-000	010-05998-000	010-05998-000
10	1 qt.	Adhesive (Use with #6)	ALL	013-03311-000		
11	2	Sensor, Water Temperature	ALL	025-40334-000	025-40334-000	025-40334-000
12	2	Well, Thermo	ALL	026-33627-000	026-33427-000	026-33427-000

**TABLE 1A (CONT'D) – EVAPORATOR COMPONENTS - PIN #9 = "E" OR "V" (SEE FIG. 1, PAGE 6)**

ITEM #	QTY PER UNIT	DESCRIPTION	DWP	UNIT MODELS YCAV0157, 0177 AND YCAV00187	UNIT MODELS YCAV0197, 0207 AND YCAV0227	UNIT MODEL YCAV0247
1	1	Evaporator, Fully Insulated with Heater	ALL	375-67311-001	375-67319-001	375-67307-001
		Evaporator, less Heater & Insulation		375-67312-000	375-67320-000	375-67308-000
2	1	Head, Connection End	ALL	075-54488-000	075-53794-000	075-54488-000
3	1	Head, Back End	ALL	075-54486-000	075-53796-000	075-54486-000
4	1	Baffle, Connection End	ALL	075-54490-000	075-53790-000	075-54490-000
5	1	Baffle, Back End	ALL	075-54485-000	075-53792-000	075-54485-000
6	2	Gasket, Baffle and Head	ALL	075-54491-000	075-53797-000	075-54491-000
7	2	Heater, Cooler 280 Watt	ALL	025-22691-000	025-22691-000	025-22691-000
8	-	Insulation (3/4"x49"x65")	ALL	010-05997-000	010-05997-000	010-05997-000
9	-	Insulation (1 1/2"x49"x65")		010-05998-000	010-05998-000	010-05998-000
10	1 qt.	Adhesive (Use with #6)	ALL	013-03311-000		
11	2	Sensor, Water Temperature	ALL	025-40334-000	025-40334-000	025-40334-000
12	2	Well, Thermo	ALL	026-33627-000	026-33427-000	026-33427-000

# CONDENSER COIL COMPONENTS

POWER  
PANEL  
END OF  
CHILLER

Condenser

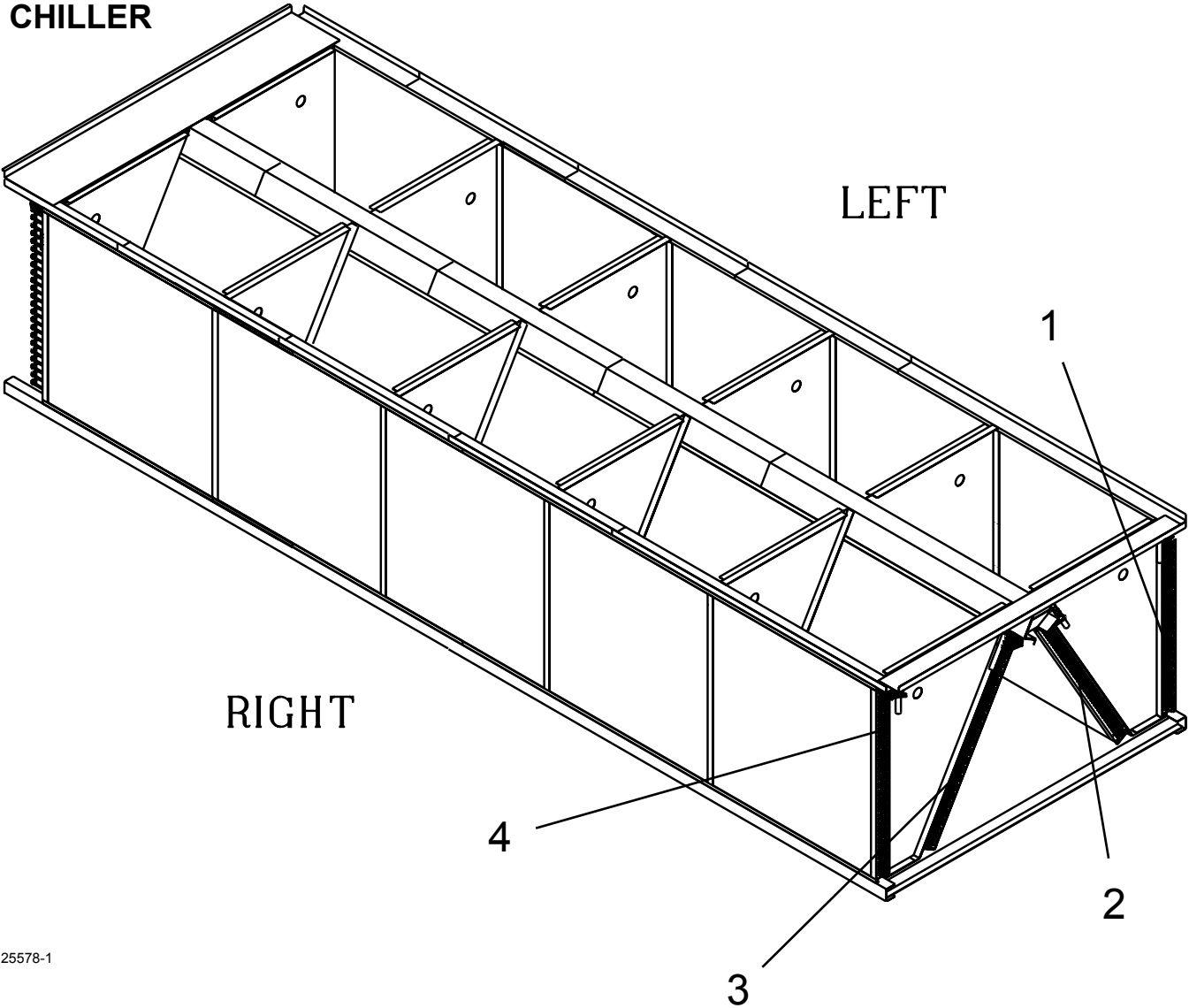

25578-1

**FIG. 2 – CONDENSER COIL COMPONENTS**  
(REF. TABLES 2 AND 2A, PAGES 10, 11, 12 AND 13)

## CONDENSER COIL COMPONENTS (CONT'D)

**TABLE 2 – CONDENSER COIL COMPONENTS - STANDARD 'PIN 9 = S OR P'**  
(SEE FIG. 2, PAGE 9)

ITEM NUMBER	DESCRIPTION	SYSTEM	QTY	MODELS YCAV0157 AND YCAV0177	MODELS YCAV0187 AND YCAV0207	MODEL YCAV0227
<b>ALUMINUM COILS</b>						
1	Coil Assembly*	Sys 1	1	375-55356-001	375-55350-001	375-55350-001
2			1	375-55356-002	375-55350-002	375-55350-002
3		Sys 2	1	375-55356-003	375-55356-003	375-55350-003
4			1	375-55356-004	375-55356-004	375-55350-004
<b>COPPER COILS</b>						
1	Coil Assembly*	Sys 1	1	375-55356-005	375-55350-005	375-55350-005
2			1	375-55356-006	375-55350-006	375-55350-006
3		Sys 2	1	375-55356-007	375-55356-007	375-55350-007
4			1	375-55356-008	375-55356-008	375-55350-008
<b>BLACK FIN COILS</b>						
1	Coil Assembly*	Sys 1	1	375-55356-009	375-55350-009	375-55350-009
2			1	375-55356-010	375-55350-010	375-55350-010
3		Sys 2	1	375-55356-011	375-55356-011	375-55350-011
4			1	375-55356-012	375-55356-012	375-55350-012
<b>PHENOLIC COILS</b>						
1	Coil Assembly*	Sys 1	1	375-58328-001	375-58328-005	375-58328-005
2			1	375-58328-002	375-58328-006	375-58328-006
3		Sys 2	1	375-58328-003	375-58328-003	375-58328-007
4			1	375-58328-004	375-58328-004	375-58328-008

\*Note: Coil Assembly includes coil and headers.

## CONDENSER COIL COMPONENTS (CONT'D)

**TABLE 2 (CONT'D) – CONDENSER COIL COMPONENTS - STANDARD 'PIN 9 = S OR P'**  
(SEE FIG. 2, PAGE 9)

ITEM NUMBER	DESCRIPTION	SYSTEM	QTY	MODEL YCAV0247	MODEL YCAV0267
<b>ALUMINUM FIN COILS</b>					
1	Coil Assembly*	Sys 1	1	375-54395-001	375-54395-001
2			1	375-54395-002	375-54395-002
3		Sys 2	1	375-55350-003	375-54395-003
4			1	375-55350-004	375-54395-004
<b>COPPER COILS</b>					
1	Coil Assembly*	Sys 1	1	375-54395-005	375-54395-005
2			1	375-54395-006	375-54395-006
3		Sys 2	1	375-55350-007	375-54395-007
4			1	375-55350-008	375-54395-008
<b>BLACK FIN COILS</b>					
1	Coil Assembly*	Sys 1	1	375-54395-009	375-54395-009
2			1	375-54395-010	375-54395-010
3		Sys 2	1	375-55350-011	375-54395-011
4			1	375-55350-012	375-54395-012
<b>PHENOLIC COILS</b>					
1	Coil Assembly*	Sys 1	1	375-58328-009	375-58328-009
2			1	375-58328-010	375-58328-010
3		Sys 2	1	375-58328-007	375-58328-011
4			1	375-58328-008	375-58328-012

**\*Note:** Coil Assembly includes coil and headers.

## CONDENSER COIL COMPONENTS (CONT'D)

**TABLE 2A – CONDENSER COIL COMPONENTS - HIGH EFFICIENCY 'PIN 9 = E OR V'**  
(SEE FIG. 2, PAGE 9)

ITEM NUMBER	DESCRIPTION	SYSTEM	QTY	MODEL YCAV0157	MODEL YCAV0177	MODELS YCAV0187 AND YCAV0197
<b>ALUMINUM COILS</b>						
1	Coil Assembly*	Sys 1	1	375-55356-001	375-55350-001	375-55350-001
2			1	375-55356-002	375-55350-002	375-55350-002
3		Sys 2	1	375-55356-003	375-55356-003	375-55350-003
4			1	375-55356-004	375-55356-004	375-55350-004
<b>COPPER COILS</b>						
1	Coil Assembly*	Sys 1	1	375-55356-005	375-55350-005	375-55350-005
2			1	375-55356-006	375-55350-006	375-55350-006
3		Sys 2	1	375-55356-007	375-55356-007	375-55350-007
4			1	375-55356-008	375-55356-008	375-55350-008
<b>BLACK FIN COILS</b>						
1	Coil Assembly*	Sys 1	1	375-55356-009	375-55350-009	375-55350-009
2			1	375-55356-010	375-55350-010	375-55350-010
3		Sys 2	1	375-55356-011	375-55356-011	375-55350-011
4			1	375-55356-012	375-55356-012	375-55350-012
<b>PHENOLIC COILS</b>						
1	Coil Assembly*	Sys 1	1	375-58328-001	375-58328-005	375-58328-005
2			1	375-58328-002	375-58328-006	375-58328-006
3		Sys 2	1	375-58328-003	375-58328-003	375-58328-007
4			1	375-58328-004	375-58328-004	375-58328-008

\*Note: Coil Assembly includes coil and headers.

## CONDENSER COIL COMPONENTS (CONT'D)

**TABLE 2A (CONT'D) – CONDENSER COIL COMPONENTS - HIGH EFFICIENCY 'PIN 9 = E OR V' (SEE FIG. 2, PAGE 9)**

ITEM NUMBER	DESCRIPTION	SYSTEM	QTY	MODEL YCAV0207	MODELS YCAV0227 AND YCAV0247
<b>ALUMINUM FIN COILS</b>					
1	Coil Assembly*	Sys 1	1	375-54395-001	375-54395-001
2			1	375-54395-002	375-54395-002
3		Sys 2	1	375-55350-003	375-54395-003
4			1	375-55350-004	375-54395-004
<b>COPPER COILS</b>					
1	Coil Assembly*	Sys 1	1	375-54395-005	375-54395-005
2			1	375-54395-006	375-54395-006
3		Sys 2	1	375-55350-007	375-54395-007
4			1	375-55350-008	375-54395-008
<b>BLACK FIN COILS</b>					
1	Coil Assembly*	Sys 1	1	375-54395-009	375-54395-009
2			1	375-54395-010	375-54395-010
3		Sys 2	1	375-55350-011	375-54395-011
4			1	375-55350-012	375-54395-012
<b>PHENOLIC COILS</b>					
1	Coil Assembly*	Sys 1	1	375-58328-009	375-58328-009
2			1	375-58328-010	375-58328-010
3		Sys 2	1	375-58328-007	375-58328-011
4			1	375-58328-008	375-58328-012

**\*Note:** Coil Assembly includes coil and headers.

# FAN COMPONENTS

**Service Note:**

Fan Hub to Shaft Joint should be sealed with protective coating - use RUST VETO 344 - a solvent type, rust preventative coating.

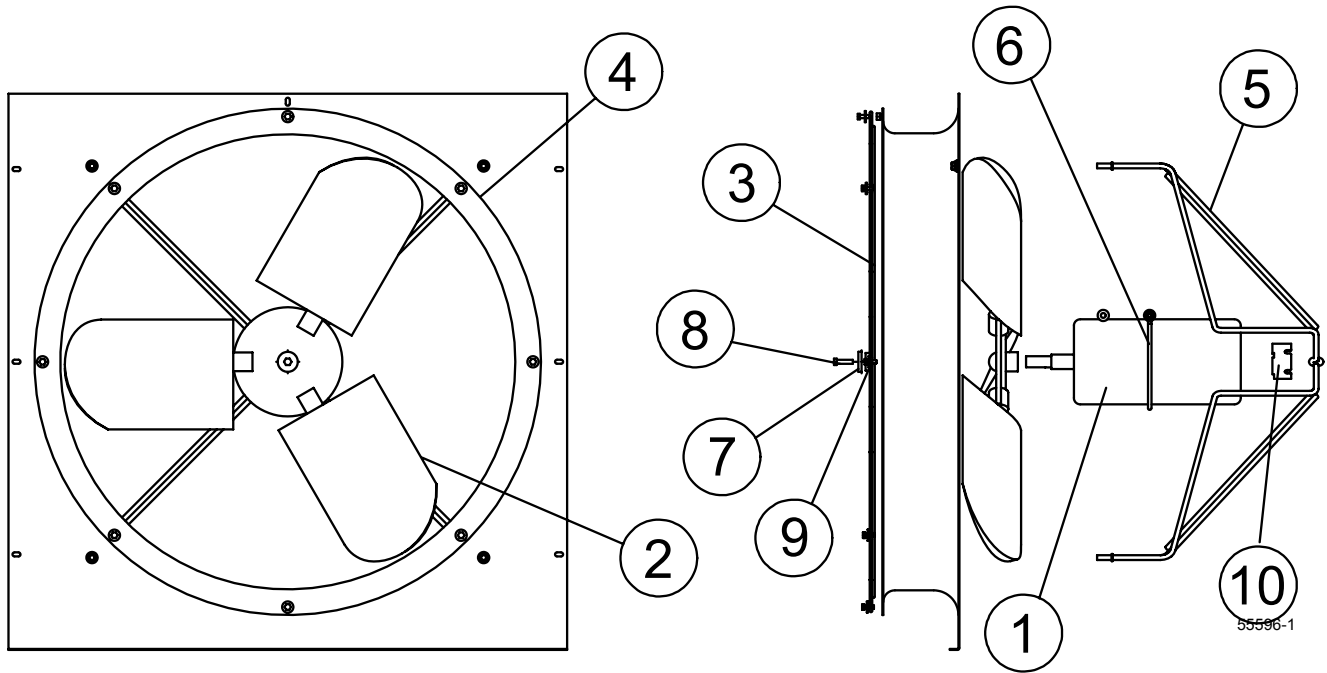

**Service Note:** Pin Location 52 in Model Number will be "X" for Standard Fan, or "L" for Low Noise Fan. See page 4.

**FIG. 3 – FAN COMPONENTS**

**TABLE 3 – FAN COMPONENTS**

ITEM NUMBER	DESCRIPTION	VOLTAGE CODE	FAN TYPE	
			STANDARD 7/8", 1160 RPM	ULTRA QUIET 7/8", 850 RPM
1 <sup>s</sup>	Motor, Fan 2 HP (YCAV0157 - YCAV0267) (YCAV0569 - YCAV0969)	-17	024-27322-207	024-34980-101
		-28		
		-40		
		-46		
		-58	024-27322-108	
2 <sup>s</sup>	Blade (YCAV0157 - YCAV0267)	All	026-41594-000	026-41942-000
	Blade (YCAV0569 - YCAV0969)		026-41943-000	026-41601-000
3	Guard	All	026-35605-000	
4	Orifice	All	026-41609-000	
5	Support	All	026-41937-000	026-41938-000
6	Support Ring	All	026-36367-000	
7	Spacer (.375 I.D.)	All	075-29007-000	
8	Screw, Cap (M8x125)	All	021-18494-000	
9	Spacer (1.406 I.D.)	All	075-40484-000	

<sup>s</sup> = Recommended Spare Parts

*This page intentionally left blank*

# REFRIGERANT PIPING COMPONENTS

## CHILLER MODEL YCAV

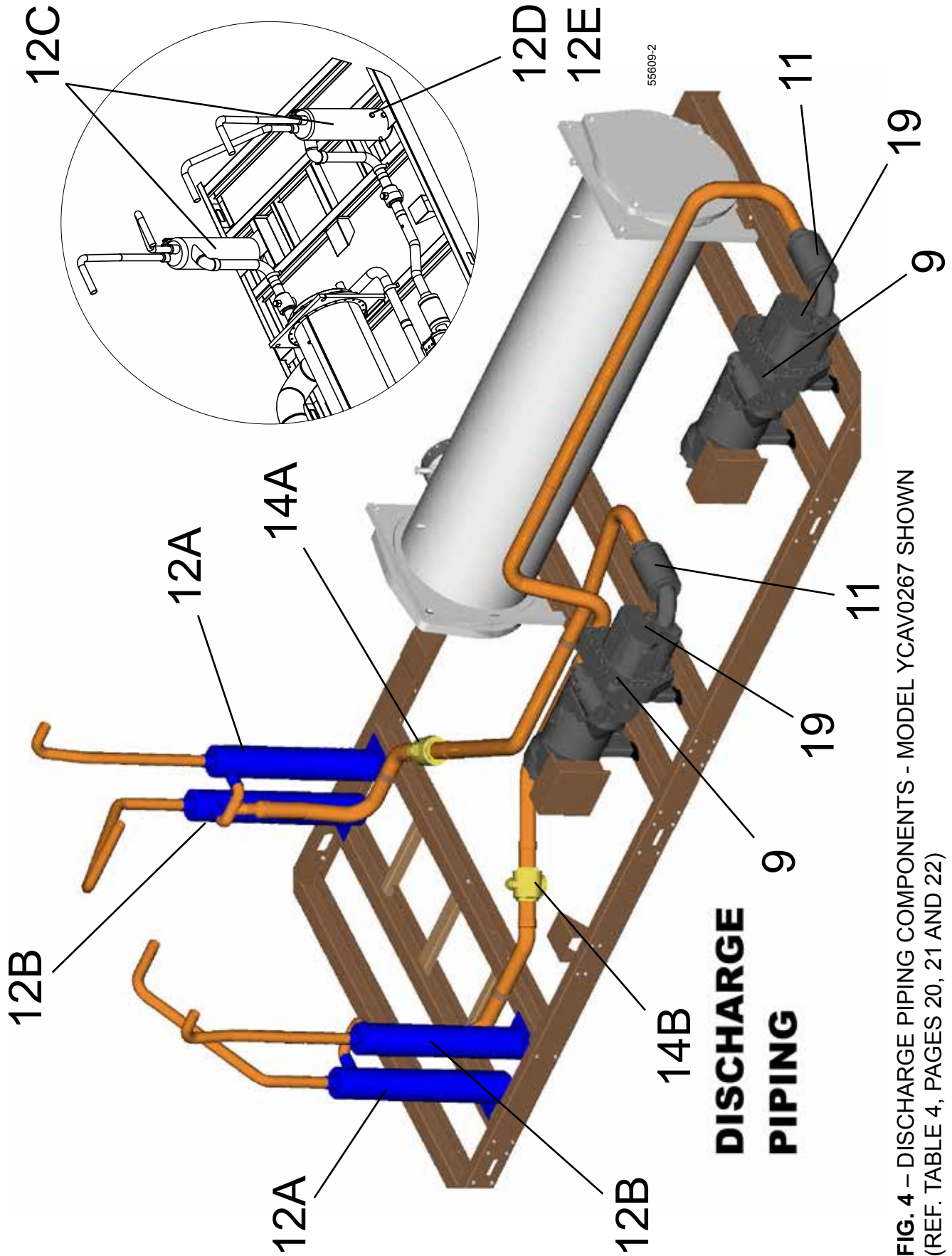

Piping

**DISCHARGE  
PIPING**

**FIG. 4 – DISCHARGE PIPING COMPONENTS - MODEL YCAV0267 SHOWN**  
(REF. TABLE 4, PAGES 20, 21 AND 22)

# REFRIGERANT PIPING COMPONENTS (CONT'D)

## CHILLER MODEL YCAV

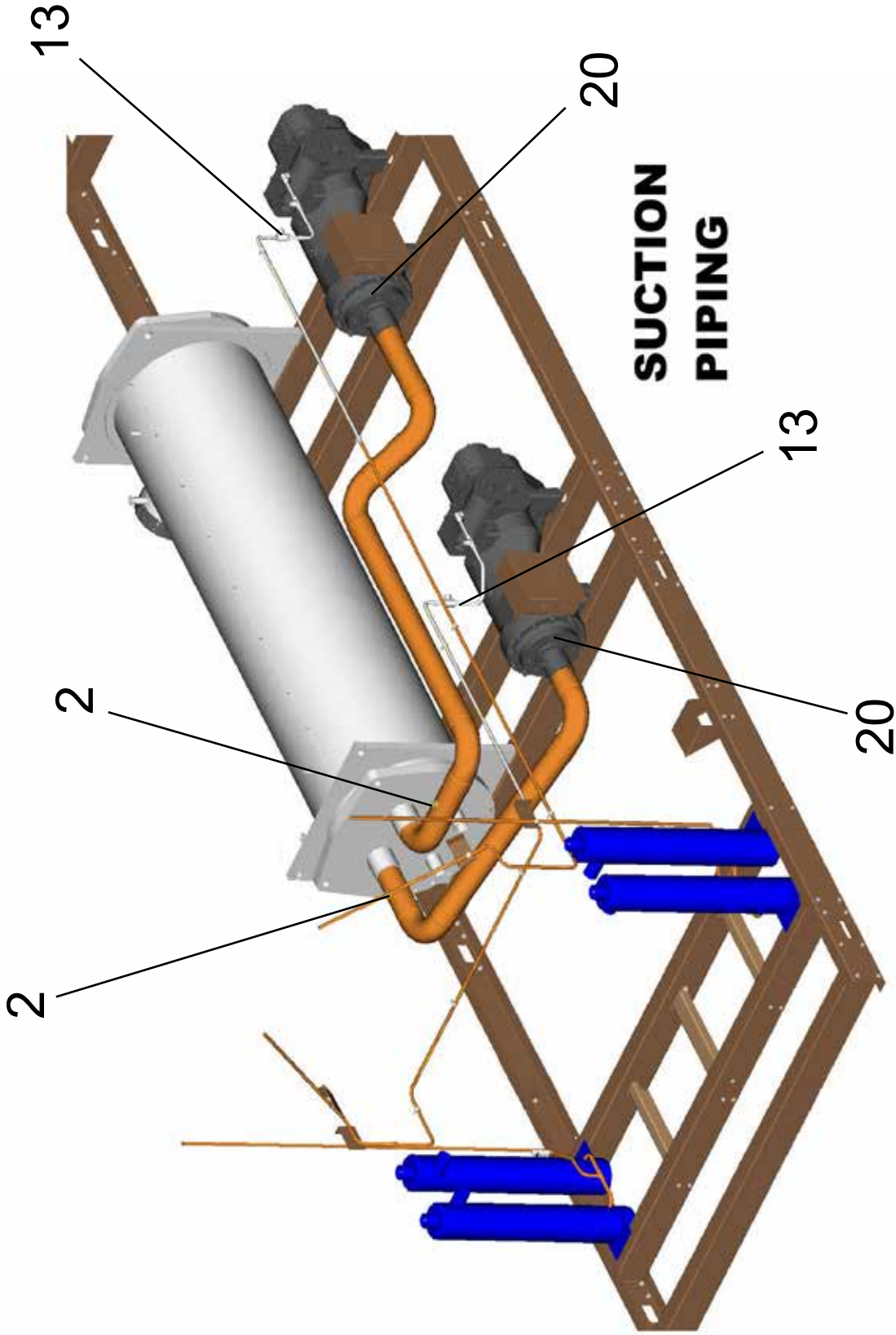

55609-5

**FIG. 4A** – SUCTION PIPING COMPONENTS - MODEL YCAV0267 SHOWN  
(REF. TABLE 4, PAGES 20, 21 AND 22)

Piping

# REFRIGERANT PIPING COMPONENTS (CONT'D)

## CHILLER MODEL YCAV

Piping

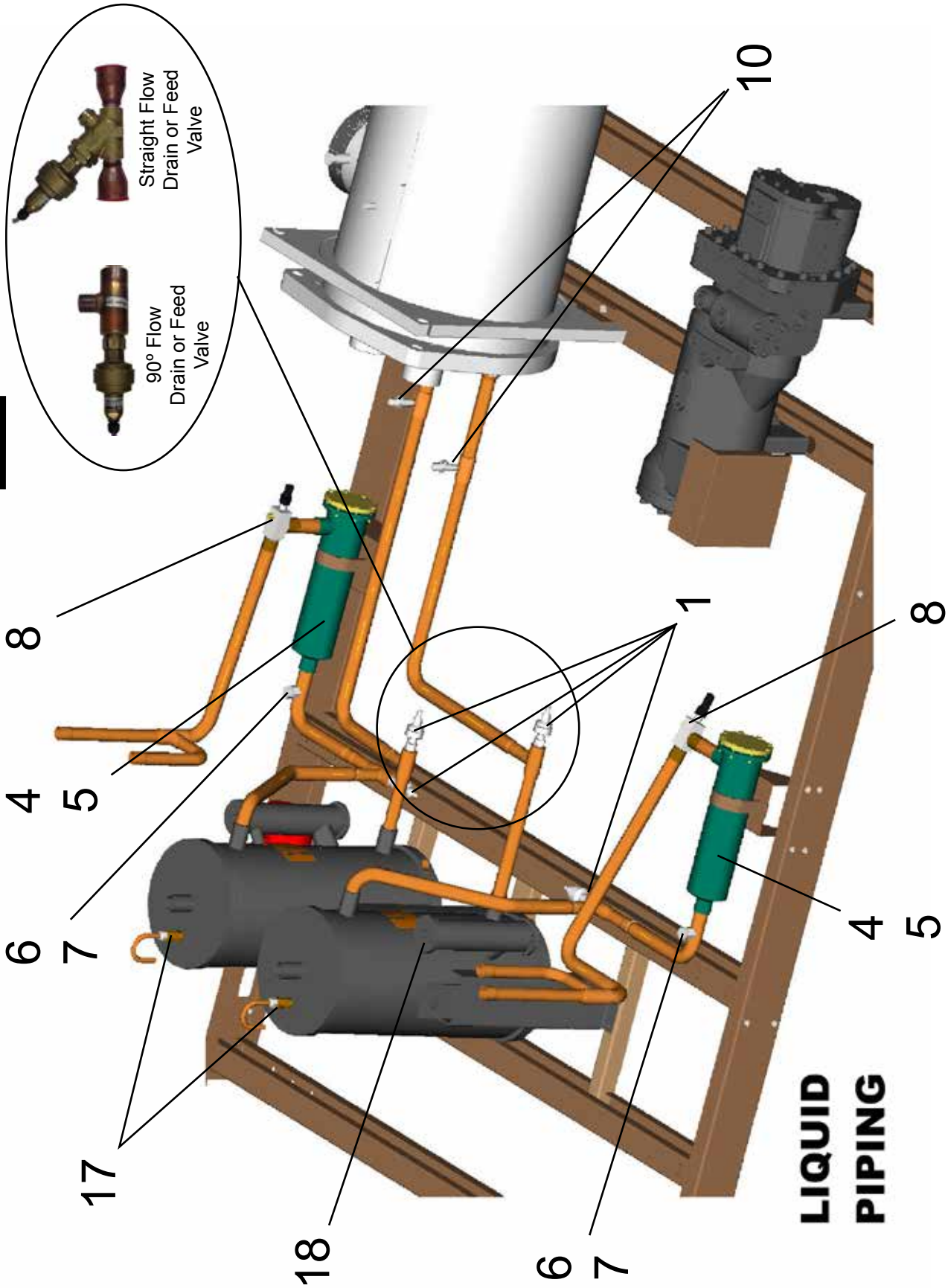

**LIQUID  
PIPING**

FIG. 4B – LIQUID PIPING COMPONENTS - MODEL YCAV0267 SHOWN (REF. TABLE 4, PAGES 20, 21 AND 22)

# REFRIGERANT PIPING COMPONENTS (CONT'D)

## CHILLER MODEL YCAV

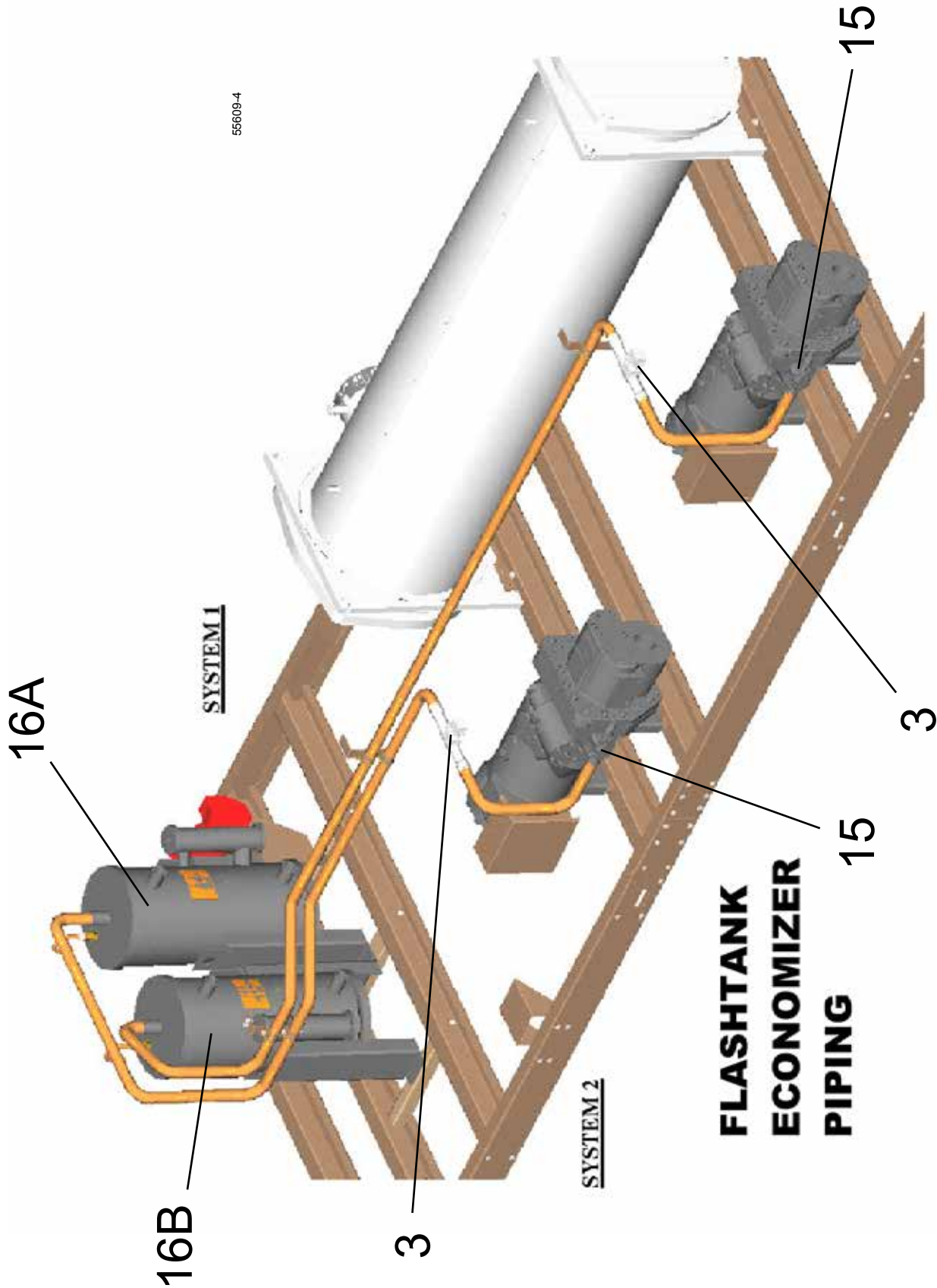

FIG. 4C – LIQUID PIPING COMPONENTS - MODEL YCAV0267 SHOWN (REF. TABLE 4, PAGES 20, 21 AND 22)

## REFRIGERANT PIPING COMPONENTS (CONT'D)

### CHILLER MODEL YCAV

**TABLE 4 – REFRIGERANT PIPING COMPONENTS**  
(SEE FIGS. 4, 4A, 4B AND 4C, PAGES 16, 17, 18 AND 19)

ITEM NO.	QTY PER UNIT	DESCRIPTION	YCAV00157	YCAV0177	YCAV0187
1 <sup>S</sup>	4	Valve, Drain or Feed - 90° Flow*	025-41564-000	025-41564-000	025-41564-000
	4	Valve, Drain or Feed - Straight Flow**	025-41565-000	025-41565-000	025-41565-000
2	2	Valve, Low Side Relief - 235#	022-11312-000	022-11312-000	022-11312-000
3	2	Valve, Economizer Solenoid	025-40330-000	025-40330-000	025-40330-000
4	2	Dehydrator, Body (Replacable Core)	026-16960-000	026-16960-000	026-16960-000
5 <sup>S</sup>	6	Core, Dehydrator	026-37540-000	026-37540-000	026-37540-000
6	2	Moisture Indicator, Body	026-32399-000	026-32399-000	026-32399-000
7	2	Moisture Indicator, Sight Glass Cap	026-32800-000	026-32800-000	026-32800-000
8	2	Valve, Liquid Stop	022-09779-000	022-09779-000	022-09779-000
9	2	Compressor, MTS	See page 27		
10	4	Valve, Charging	022-09754-000	022-09754-000	022-09754-000
11	2	Muffler	375-55738-000	375-55738-000	375-55738-000
12A	2	Dual Oil Separator (Left)	026-42901-100		
12B	2	Dual Oil Separator (Right)	026-42901-200		
12C	2	Single Oil Separator	026-42901-000		
12D	2	Sight Glass, Oil Separator (All)	026-43375-000		
12E	2	O-ring, Sight Glass	028-15574-000		
13	2	Valve, Ball (Oil Line)	022-09172-000	022-09172-000	022-09172-000
14A	1	Ball Valve, Discharge (System 1)	022-11326-000	022-11325-000	022-11325-000
14B	1	Ball Valve, Discharge (System 2)	022-11326-000	022-11326-000	022-11326-000
15	2	Flange, Economizer	022-11358-000	022-11358-000	022-11358-000
	2	1 1/2" Economizer O-ring	028-13963-000	028-13963-000	028-13963-000
16A	1	Flash Tank	375-55873-000	375-55873-000	375-55873-000
16B	1		375-54434-000	375-54434-000	375-54434-000
17	2	Valve, High Side Relief - 330#	022-11398-000	022-11398-000	022-11398-000
18 <sup>S</sup>	2	Sensor, Refrig Level	025-40274-000	025-40274-000	025-40274-000
19	2	Gasket, Compressor Discharge	028-15296-000	028-15296-000	028-15296-000
20	2	Gasket, Compressor Suction	028-15075-159	028-15075-159	028-15075-159

<sup>S</sup> = Recommended Spare Parts



\*90° Flow  
Drain or Feed  
Valve



\*\*Straight Flow  
Drain or Feed  
Valve

## REFRIGERANT PIPING COMPONENTS (CONT'D)

### CHILLER MODEL YCAV

**TABLE 4 (CONT'D) – REFRIGERANT PIPING COMPONENTS**  
(SEE FIGS. 4, 4A, 4B AND 4C, PAGES 16, 17, 18 AND 19)

ITEM NO.	QTY PER UNIT	DESCRIPTION	YCAV00197 N/A	YCAV0207	YCAV0227
<b>1<sup>S</sup></b>	4	Valve, Drain or Feed - 90° Flow*	N/A	025-41564-000	025-41564-000
	4	Valve, Drain or Feed - Straight Flow**		025-41565-000	025-41565-000
<b>2</b>	2	Valve, Low Side Relief - 235#	N/A	022-11312-000	022-11312-000
<b>3</b>	2	Valve, Economizer Solenoid	N/A	025-40330-000	025-40330-000
<b>4</b>	2	Dehydrator, Body (Replacable Core)	N/A	026-16960-000	026-16960-000
<b>5<sup>S</sup></b>	6	Core, Dehydrator	N/A	026-37540-000	026-37540-000
<b>6</b>	2	Moisture Indicator, Body	N/A	026-32399-000	026-32399-000
<b>7</b>	2	Moisture Indicator, Sight Glass Cap	N/A	026-32800-000	026-32800-000
<b>8</b>	2	Valve, Liquid Stop	N/A	022-09779-000	022-09779-000
<b>9</b>	2	Compressor, MTS	See page 27		
<b>10</b>	4	Valve, Charging	N/A	022-09754-000	022-09754-000
<b>11</b>	2	Muffler	N/A	375-53202-000	375-53202-000
<b>12A</b>	2	Dual Oil Separator (Left)	N/A	026-42901-100	
<b>12B</b>	2	Dual Oil Separator (Right)	N/A	026-42901-200	
<b>12C</b>	2	Single Oil Separator	N/A	026-42901-000	
<b>12D</b>	2	Sight Glass, Oil Separator (All)	N/A	026-43375-000	
<b>12E</b>	2	O-ring, Sight Glass	N/A	028-15574-000	
<b>13</b>	2	Valve, Ball (Oil Line)	N/A	022-09172-000	022-09172-000
<b>14A</b>	1	Ball Valve, Discharge (System 1)	N/A	022-11325-000	022-11325-000
<b>14B</b>	1	Ball Valve, Discharge (System 2)	N/A	022-11325-000	022-11325-000
<b>15</b>	2	Flange, Economizer	N/A	022-11358-000	022-11358-000
	2	1 1/2" Economizer O-ring	N/A	028-13963-000	028-13963-000
<b>16A</b>	1	Flash Tank	N/A	375-55873-000	375-55873-000
<b>16B</b>	1		N/A	375-54434-000	375-54434-000
<b>17</b>	2	Valve, High Side Relief - 330#	N/A	022-11398-000	022-11398-000
<b>18<sup>S</sup></b>	2	Sensor, Refrig Level	N/A	025-40274-000	025-40274-000
<b>19</b>	2	Gasket, Compressor Discharge	N/A	028-15296-000	028-15296-000
<b>20</b>	2	Gasket, Compressor Suction	N/A	028-15075-159	028-15075-159

<sup>S</sup> = Recommended Spare Parts



\*90° Flow  
Drain or Feed  
Valve



\*\*Straight Flow  
Drain or Feed  
Valve

# REFRIGERANT PIPING COMPONENTS (CONT'D)

## CHILLER MODEL YCAV

**TABLE 4 (CONT'D) – REFRIGERANT PIPING COMPONENTS**  
(SEE FIGS. 4, 4A, 4B AND 4C, PAGES 16, 17, 18 AND 19)

ITEM NO.	QTY PER UNIT	DESCRIPTION	YCAV00247	YCAV0267
<b>1<sup>S</sup></b>	4	Valve, Drain or Feed - 90° Flow*	025-41564-000	025-41564-000
	4	Valve, Drain or Feed - Straight Flow**	025-41565-000	025-41565-000
<b>2</b>	2	Valve, Low Side Relief - 235#	022-11312-000	022-11312-000
<b>3</b>	2	Valve, Economizer Solenoid	025-40330-000	025-40330-000
<b>4</b>	2	Dehydrator, Body (Replacable Core)	026-16960-000	026-16960-000
<b>5<sup>S</sup></b>	6	Core, Dehydrator	026-37540-000	026-37540-000
<b>6</b>	2	Moisture Indicator, Body	026-32399-000	026-32399-000
<b>7</b>	2	Moisture Indicator, Sight Glass Cap	026-32800-000	026-32800-000
<b>8</b>	2	Valve, Liquid Stop	022-09779-000	022-09779-000
<b>9</b>	2	Compressor, MTS	See page 27	
<b>10</b>	4	Valve, Charging	022-09754-000	022-09754-000
<b>11</b>	2	Muffler	375-53202-000	375-53202-000
<b>12A</b>	2	Dual Oil Separator (Left)	026-42901-100	
<b>12B</b>	2	Dual Oil Separator (Right)	026-42901-200	
<b>12C</b>	2	Single Oil Separator	026-42901-000	
<b>12D</b>	2	Sight Glass, Oil Separator (All)	026-43375-000	
<b>12E</b>	2	O-ring, Sight Glass	028-15574-000	
<b>13</b>	2	Valve, Ball (Oil Line)	022-09172-000	022-09172-000
<b>14A</b>	1	Ball Valve, Discharge (System 1)	022-11325-000	022-11325-000
<b>14B</b>	1	Ball Valve, Discharge (System 2)	022-11325-000	022-11325-000
<b>15</b>	2	Flange, Economizer	022-11358-000	022-11358-000
	2	1 1/2" Economizer O-ring	028-13963-000	028-13963-000
<b>16A</b>	1	Flash Tank	375-55873-000	375-55873-000
<b>16B</b>	1		375-54434-000	375-54434-000
<b>17</b>	4	Valve, High Side Relief - 330#	022-11398-000	022-11398-000
<b>18<sup>S</sup></b>	2	Sensor, Refrig Level	025-40274-000	025-40274-000
<b>19</b>	2	Gasket, Compressor Discharge	028-15296-000	028-15296-000
<b>20</b>	2	Gasket, Compressor Suction	028-15075-159	028-15075-159

<sup>S</sup> = Recommended Spare Parts



\*90° Flow  
Drain or Feed  
Valve



\*\*Straight Flow  
Drain or Feed  
Valve

## REFRIGERANT PIPING COMPONENTS (CONT'D)

### CHILLER MODEL YCAV

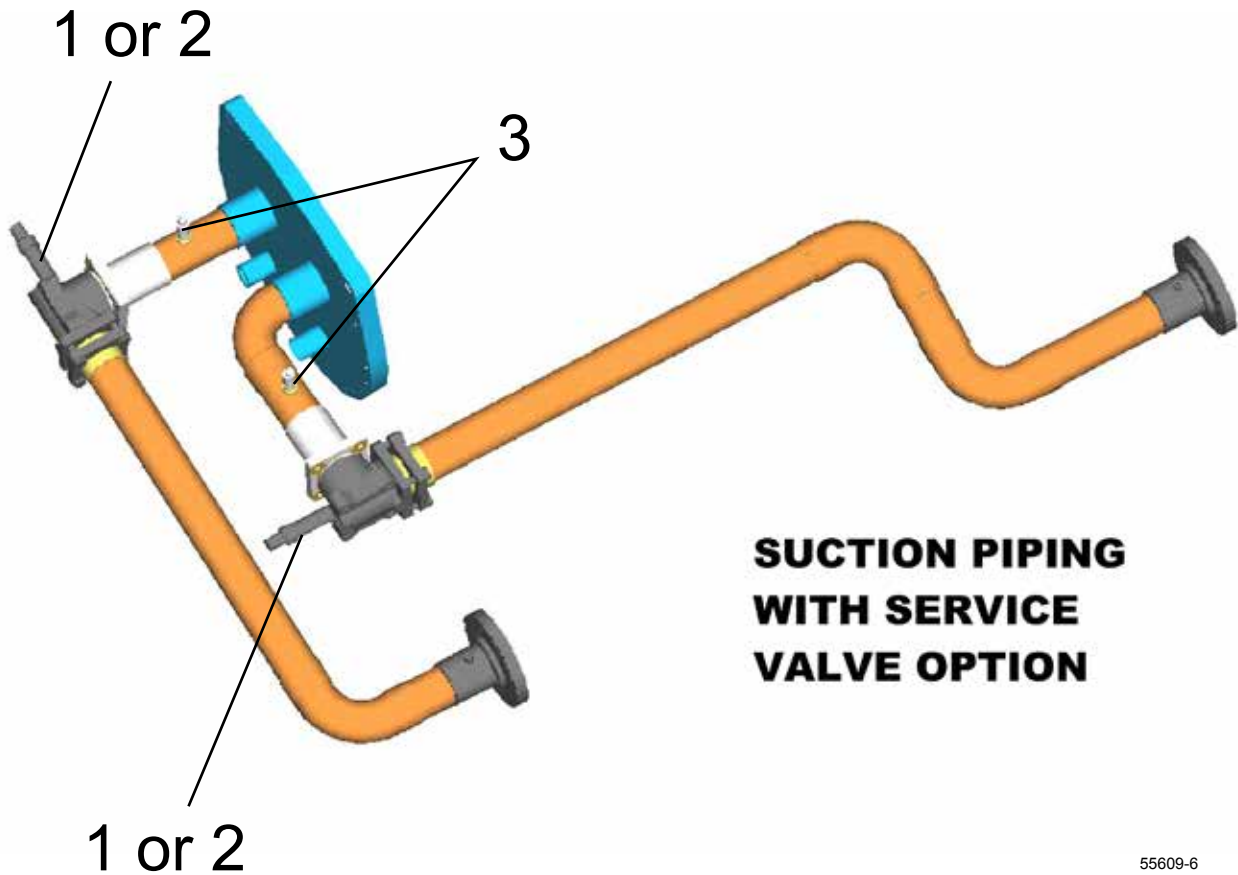

Piping

55609-6

**FIG. 4D** – SUCTION PIPING WITH SERVICE VALVE OPTION COMPONENTS (REF. TABLE 4A)

**TABLE 4A** – SUCTION PIPING WITH SERVICE VALVE OPTION COMPONENTS (SEE FIG. 4D)

ITEM NO.	COMPRESSOR MODEL	DESCRIPTION	PART NUMBER
1	MTS 24 and MTS 36	Valve, Stop (3 5/8")	022-02845-001
		Gasket	028-13974-000
2	MTS 45	Valve, Stop (4 1/8")	022-11340-001
		Gasket	028-15304-000
3	ALL	Valve, Low Side Relief - 235#	022-11312-000

# GLYCOL LOOP COMPONENTS

## CHILLER MODEL YCAV

Piping

HOSE, BLACK RUBBER - 3/4 I.D.  
(028-11958-000)

SECTION	LENGTH
1	62"
2	62"
3	113"
4	49"
5	40"
6	40"
7	45"
8	45"
9	3"

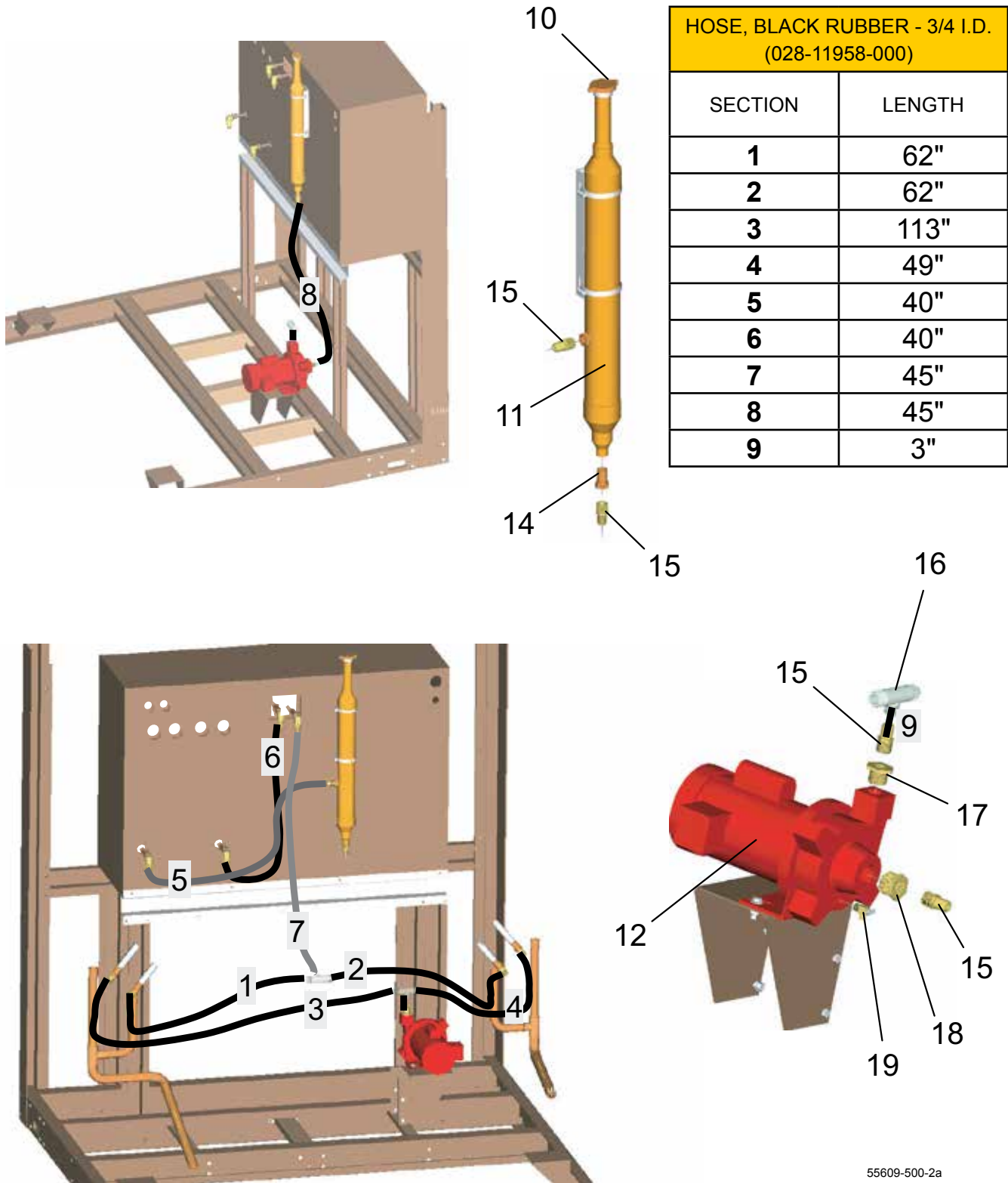

55609-500-2a

FIG. 4E – GLYCOL LOOP COMPONENTS (REF. TABLE 4B, PAGE 25)

## GLYCOL LOOP COMPONENTS (CONT'D)

### CHILLER MODEL YCAV

**TABLE 4B** – GLYCOL LOOP COMPONENTS (SEE FIG. 4E, PAGE 24)

ITEM NO.	QTY PER UNIT	DESCRIPTION	PART NUMBER
<b>10<sup>S</sup></b>	1	CAP, RADIATOR	023-21927-000
<b>11</b>	1	TUBE, GLYCOL	075-55649-000
<b>12</b>	1	PUMP, SINGLE STAGE w/ MOTOR (60 HERTZ)	026-41611-000
		PUMP, SINGLE STAGE w/ MOTOR (50 HERTZ)	026-41611-001
<b>13<sup>S</sup></b>	5 gal	COOLANT, PROPYLENE GLYCOL <sup>†</sup>	013-03344-000
<b>14</b>	1	REDUCER	023-21941-000
<b>15</b>	4	FITTING, HOSE BARB	023-21929-000
<b>16</b>	1	TEE	023-22526-000
<b>17</b>	1	BUSHING	023-21934-000
<b>18</b>	1	BUSHING	023-21935-000
<b>19</b>	1	VALVE, DRAIN	023-21874-000

<sup>S</sup> = Recommended Spare Parts

**† Note:**

VSD cooling system capacity ≈ 3.5 gallons. Fill level when cold = 9"-15" below cap.

**CAUTION:** Use only Glycol, part number 013-03344-000, with special inhibitors and heat characteristics. Mixing other types of Glycol or the addition of water may cause permanent damage to the cooling system.

# COMPRESSOR MODEL NOMENCLATURE

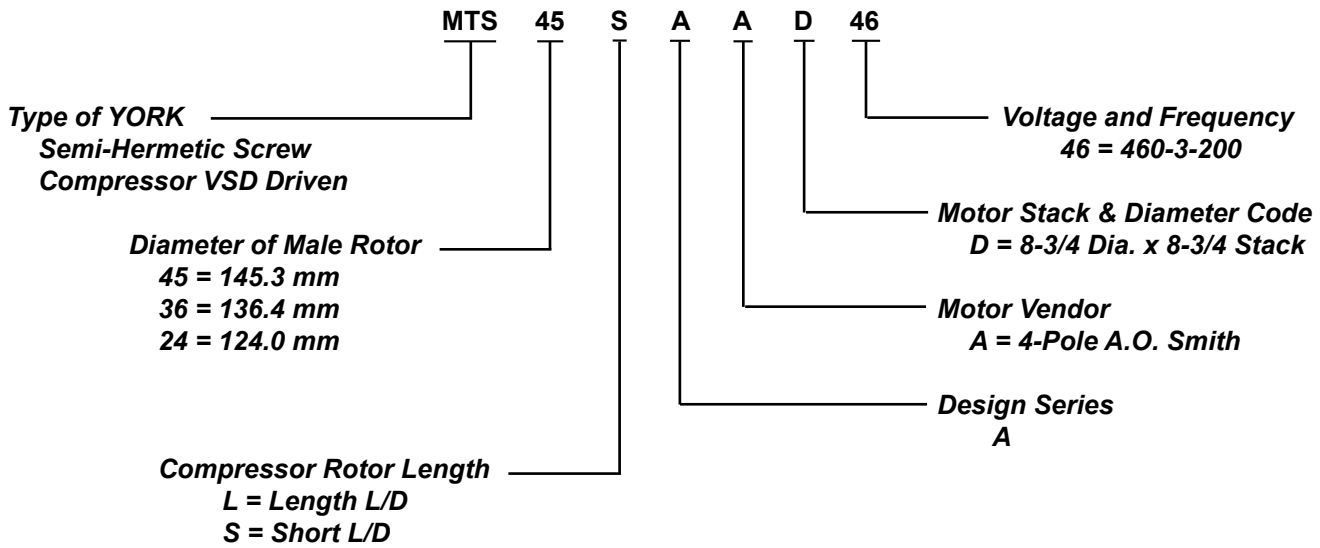

Compressor

COMPRESSOR WEIGHTS		
MM SIZE	WEIGHT (LBS.)†	WEIGHT (Kg.)
145	1310	594
136	1250	567
124	1175	533
112	760	345

†Note: Less Service Valves.

ITEM	REF.	DESCRIPTION	5 GALLON
OIL <sup>s</sup>	R-134A	Oil, Type 'L' (Synthetic)	011-00592-000

<sup>s</sup> = Recommended Spare Parts

DESCRIPTION	PART NUMBER
COMPRESSOR HEATER	025-32938-000

# COMPRESSOR

**TABLE 5 – STANDARD MODEL COMPRESSOR PART NUMBERS - S OR P**

MODEL	VOLTAGE CODE	SYSTEM #1 COMPRESSOR				SYSTEM #2 COMPRESSOR			
		PART #	MODEL #	MM	QTY	PART #	MODEL #	MM	QTY
YCAV0157	-17, -28, -40, -46 & -58	364-50820-000	MTS24SA	124	1	364-50820-000	MTS24SA	124	1
YCAV0177	-17, -28, -40, -46 & -58	364-50821-000	MTS36SA	136	1	364-50820-000	MTS24SA	124	1
YCAV0187	-17, -28, -40, -46 & -58	364-50821-000	MTS36SA	136	1	364-50820-000	MTS24SA	124	1
YCAV0207	-17, -28, -40, -46 & -58	364-50821-000	MTS36SA	136	1	364-50821-000	MTS36SA	136	1
YCAV0227	-17, -28, -40, -46 & -58	364-50821-000	MTS36SA	136	1	364-50821-000	MTS36SA	136	1
YCAV0247	-17, -28, -40, -46 & -58	364-50822-000	MTS45SA	145	1	364-50821-000	MTS36SA	136	1
YCAV0267	-17, -28, -40, -46 & -58	364-50822-000	MTS45SA	145	1	364-50822-000	MTS45SA	145	1

**TABLE 5A – HIGH EFFICIENCY MODEL COMPRESSOR PART NUMBERS - E OR V**

MODEL	VOLTAGE CODE	SYSTEM #1 COMPRESSOR				SYSTEM #2 COMPRESSOR			
		PART #	MODEL #	MM	QTY	PART #	MODEL #	MM	QTY
YCAV0157	-17, -28, -40, -46 & -58	364-50820-000	MTS24SA	124	1	364-50820-000	MTS24SA	124	1
YCAV0177	-17, -28, -40, -46 & -58	364-50820-000	MTS24SA	124	1	364-50820-000	MTS24SA	124	1
YCAV0187	-17, -28, -40, -46 & -58	364-50821-000	MTS36SA	136	1	364-50820-000	MTS24SA	124	1
YCAV0197	-17, -28, -40, -46 & -58	364-50821-000	MTS36SA	136	1	364-50821-000	MTS36SA	136	1
YCAV0207	-17, -28, -40, -46 & -58	364-50821-000	MTS36SA	136	1	364-50821-000	MTS36SA	136	1
YCAV0227	-17, -28, -40, -46 & -58	364-50821-000	MTS36SA	136	1	364-50821-000	MTS36SA	136	1
YCAV0247	-17, -28, -40, -46 & -58	364-50822-000	MTS45SA	145	1	364-50821-000	MTS36SA	136	1

**Compressor**

# CONTROL AND VSD PANEL CONFIGURATIONS

Power panels and option panels are offered in several different configurations using three (3) major components:

1. TERMINAL BLOCKS
2. CIRCUIT BREAKERS
3. NON-FUSED DISCONNECT SWITCHES

The most basic chiller power wiring configuration uses TERMINAL BLOCKS in the power panels, and an options panel with no power wire termination hardware. See figures on previous page. The model pin number locations 16 and 17 would be X and X to reflect this basic combination. Identify model pin number locations 16 and 17 to identify the chiller power wiring connections and hardware listed below.

PIN 16 & 17 LETTER CODE IDENTIFIERS		OPTION PANEL AND POWER PANEL CONFIGURATIONS
S	X	Single Point Supply Terminal Block
B	X	Single Point Supply Circuit Breaker
S	S	Single Point Supply Terminal Block w/ Separate System Non-Fused Disconnect Switch
C	S	Single Point Supply Circuit Breaker w/ Separate System Non-Fused Disconnect Switch

Key: 029-23454-000

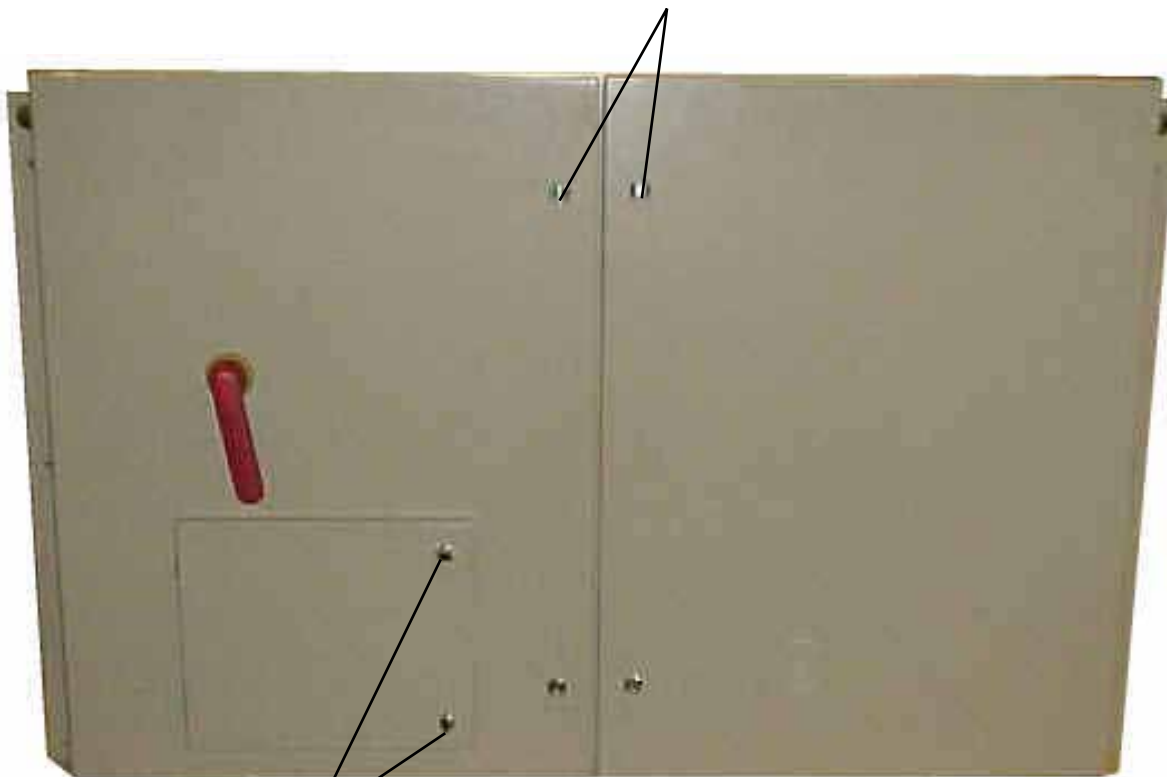

Key: 029-25104-000

Variable Speed Drive

**FIG. 5 – CONTROL, OPTIONS AND POWER PANELS LAYOUT**

## CONTROL AND VSD PANEL CONFIGURATIONS (CONT'D)

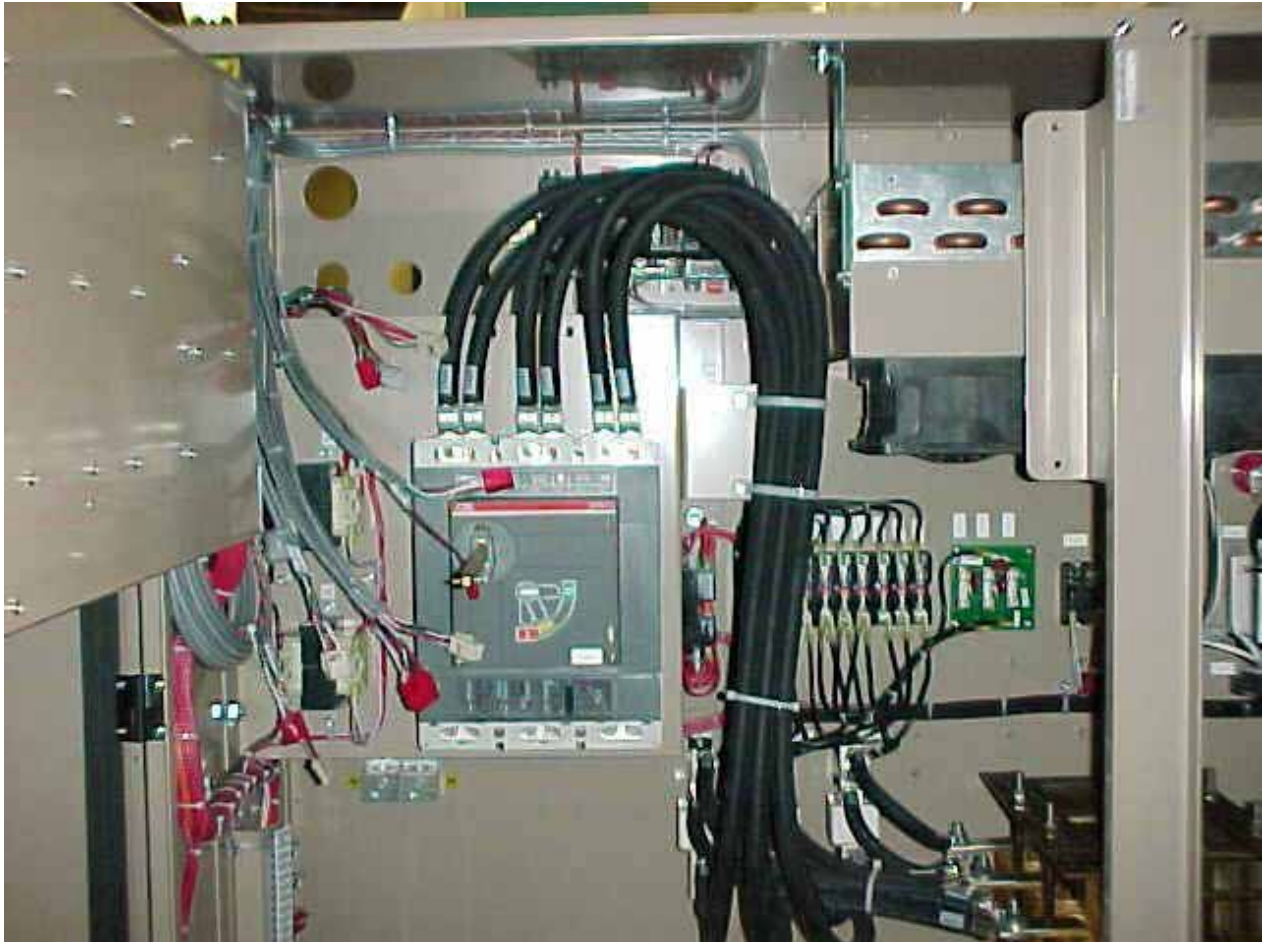

**\*Note:** *On units with Single Point Terminal Blocks, the terminal blocks are located in the same space as the Single Point Circuit Breaker shown in Fig. 7A.*

**FIG. 6 – EXAMPLES OF POWER WIRING CONFIGURATIONS (2-COMPRESSOR UNITS)**

# VARIABLE SPEED DRIVE PANEL COMPONENTS

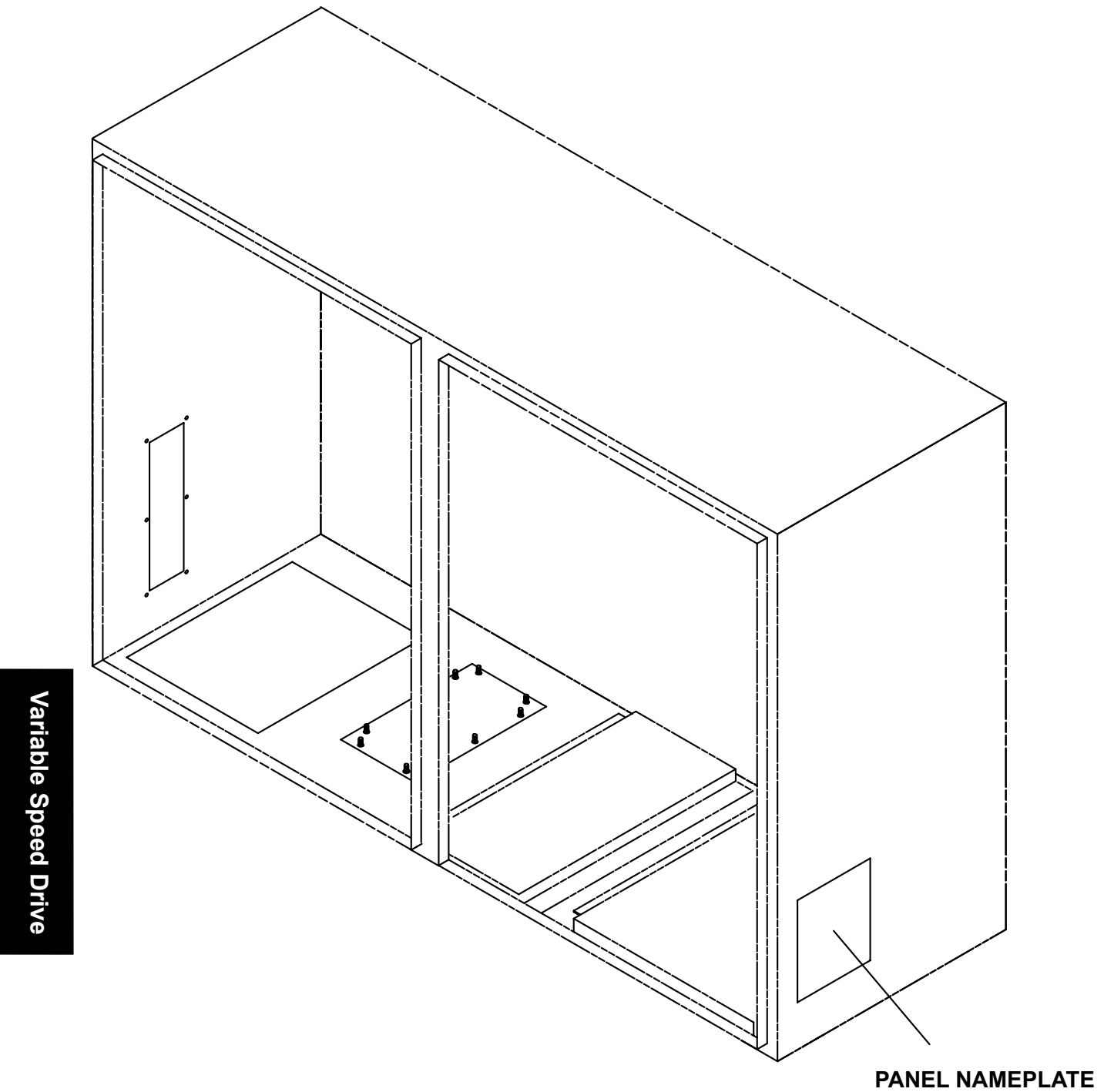

**FIG. 7 – VSD / CONTROL PANEL IDENTIFIER LOCATION (2-COMPRESSOR UNITS)**

## VARIABLE SPEED DRIVE PANEL COMPONENTS (CONT'D)

**TABLE 6** – VSD / CONTROL PANEL IDENTIFIERS (TO IDENTIFY REPLACEMENT PART NUMBERS, LOCATE THE POWER PANEL NAMEPLATE (FIG. 7, PAGE 30), SELECT PANEL IDENTIFIER NUMBER FROM THE TABLES BELOW, THEN REFER TO THE 'VSD/CONTROL PANEL COMPONENTS INFORMATION (PAGES 32-41).

VSD / Control Panel Part Numbers					
Voltage Code	Qty	Standard or Low Sound Fans			
		Terminal Block or Terminal Block w/ Separate System Non-Fused Disconnect Switches		Circuit Breaker or Circuit Breaker w/ Separate System Non-Fused Disconnect Switches	
		No Ambient Kit, Temp. Reset/ Offset and/or Current Reset/ Offset	ISN Microgateway	No Ambient Kit, Temp. Reset/ Offset and/or Current Reset/ Offset	ISN Microgateway
17	1	371-04178-101	371-04178-113	371-04178-107	371-04178-119
28		371-04178-102	371-04178-114	371-04178-108	371-04178-120
40		371-04178-103	371-04178-115	371-04178-109	371-04178-121
46		371-04178-105	371-04178-117	371-04178-111	371-04178-123
50		371-04178-104	371-04178-116	371-04178-110	371-04178-122
58		371-04178-106	371-04178-118	371-04178-112	371-04178-124

# VARIABLE SPEED DRIVE PANEL COMPONENTS

04178-04

# = COMMON PARTS  
 # = VARIABLE PARTS  
 \* # = OBSOLETE PARTS

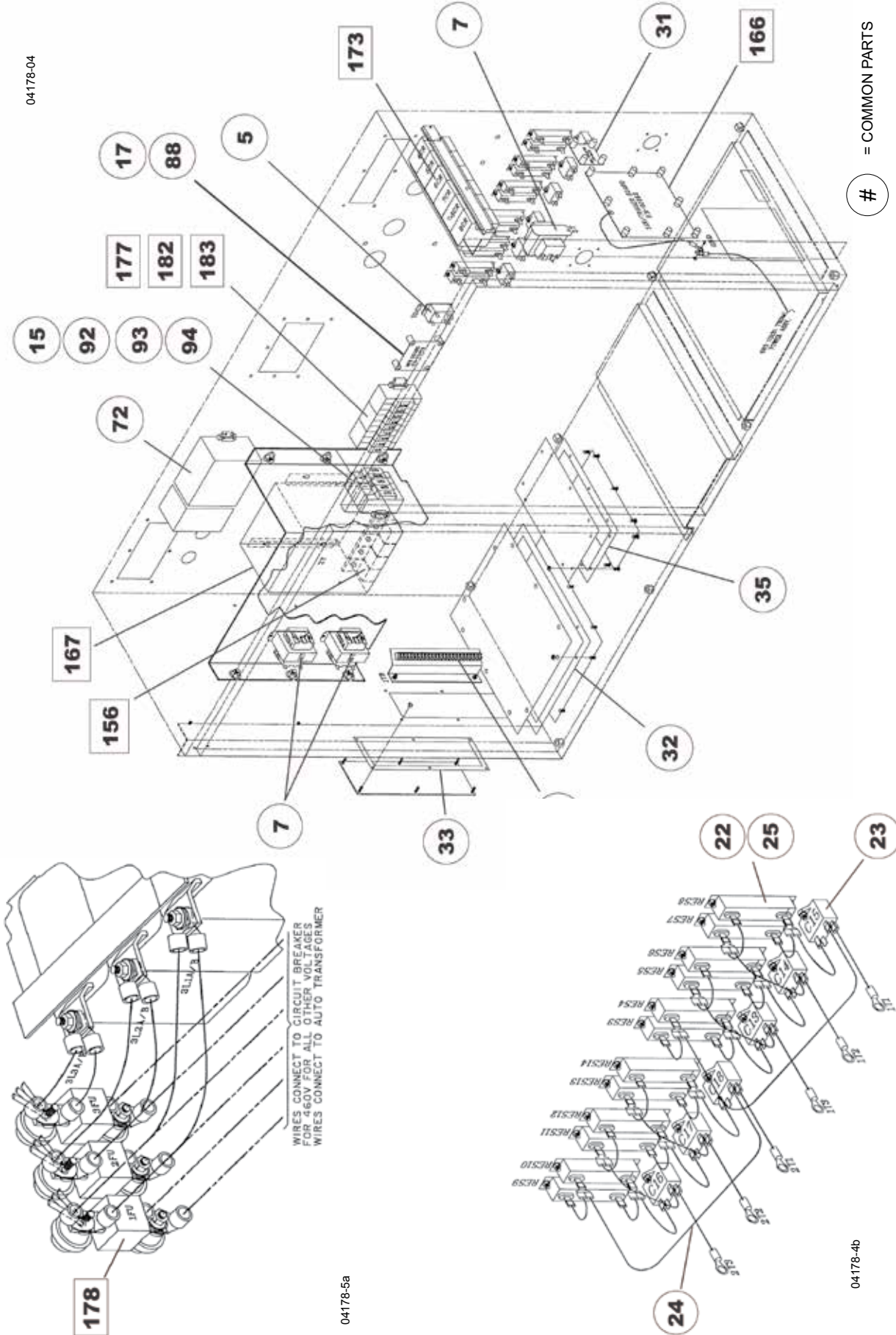

04178-5a

04178-4b

**FIG. 8 – VARIABLE SPEED DRIVE COMPONENTS (REF. 'COMMON PARTS' TABLE 7, PAGE 36 AND VARIABLE PARTS TABLE 8, PAGES 37-41)**

# VARIABLE SPEED DRIVE PANEL COMPONENTS (CONT'D)

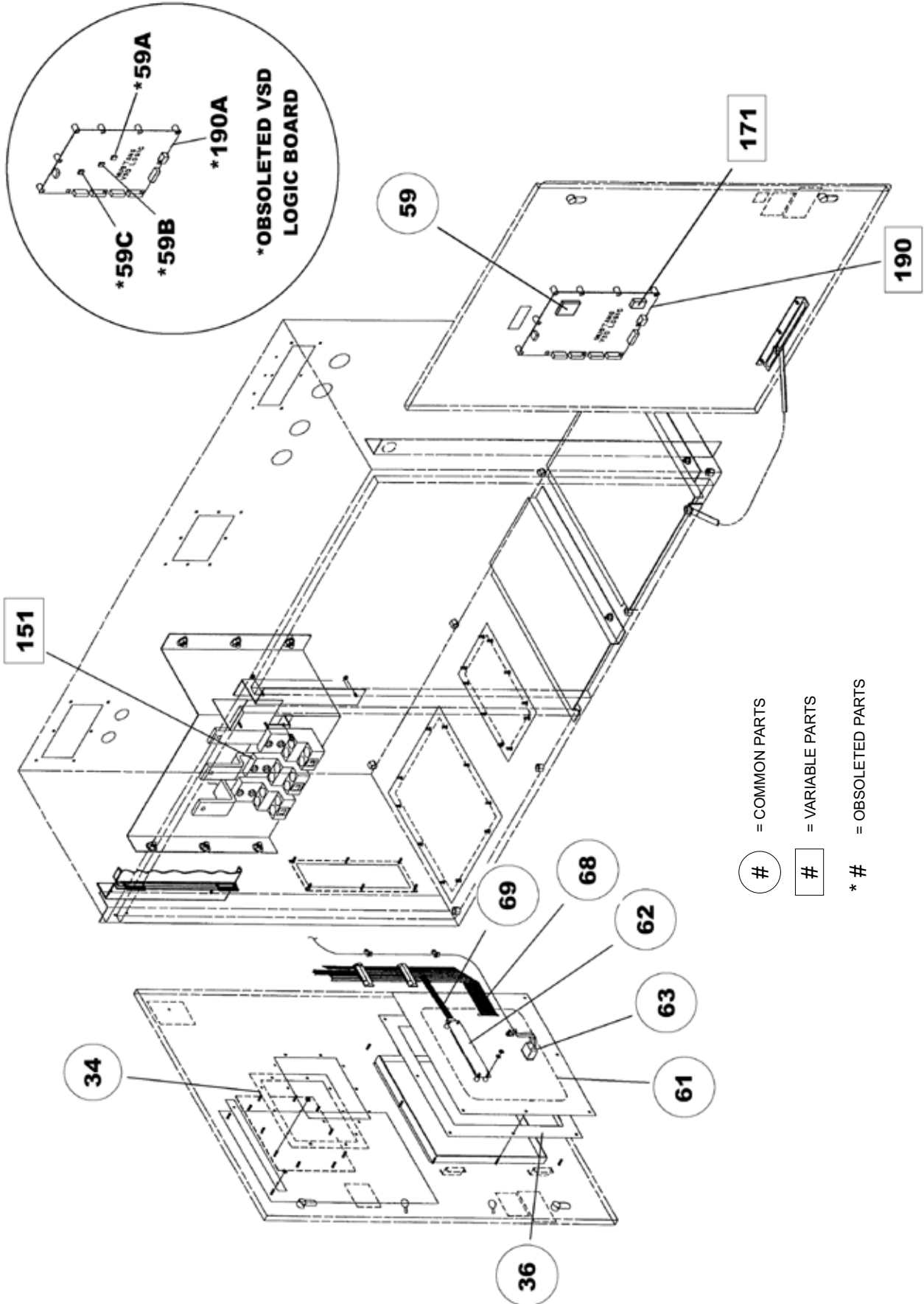

04178-06

**FIG. 8A** – VARIABLE SPEED DRIVE COMPONENTS (REF. 'COMMON PARTS' TABLE 7, PAGE 36 AND VARIABLE PARTS TABLE 8, PAGES 37-41)

# VARIABLE SPEED DRIVE PANEL COMPONENTS (CONT'D)

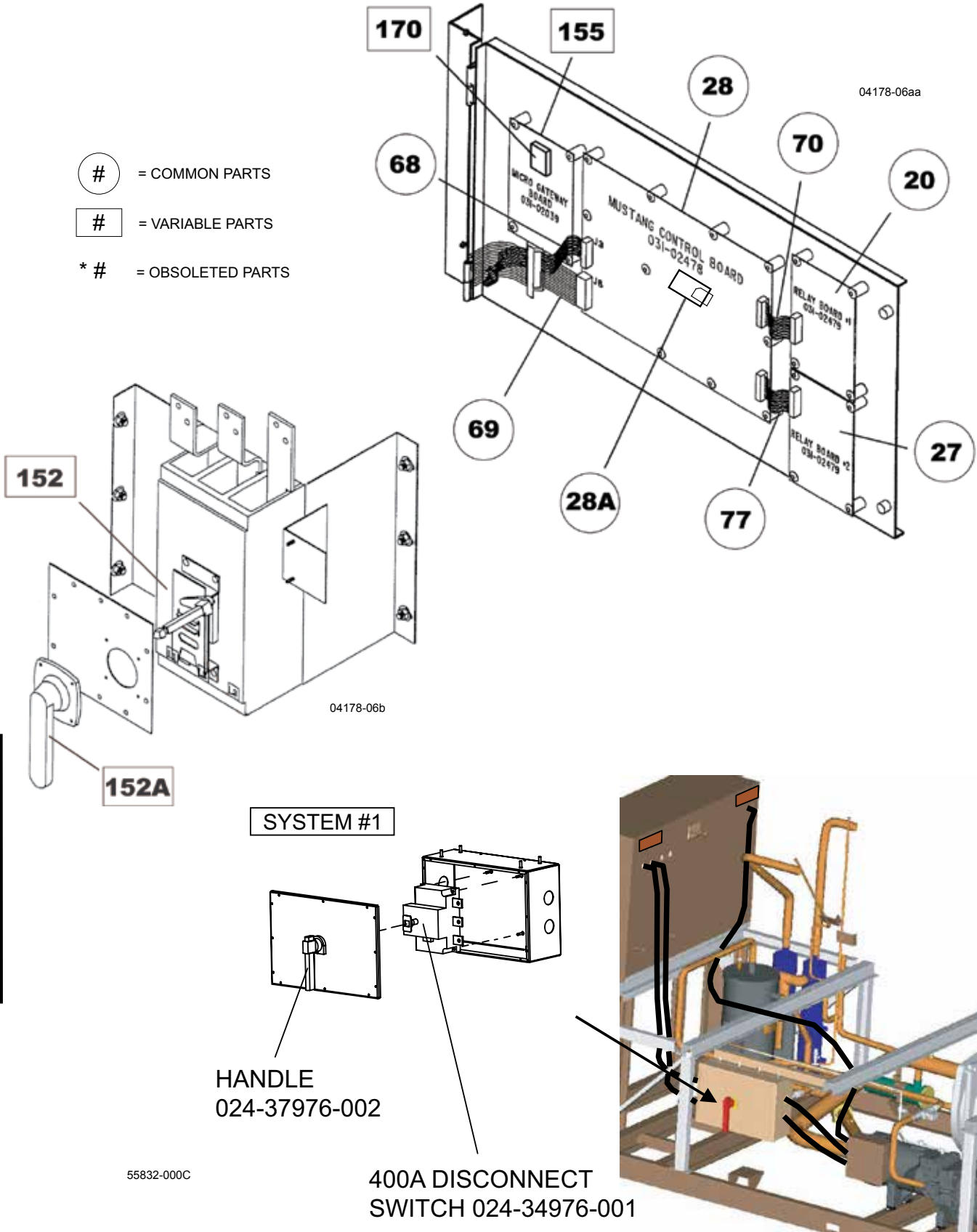

**FIG. 8B** – VARIABLE SPEED DRIVE COMPONENTS (REF. 'COMMON PARTS' TABLE 7, PAGE 36 AND VARIABLE PARTS TABLE 8, PAGES 37-41)

# VARIABLE SPEED DRIVE PANEL COMPONENTS (CONT'D)

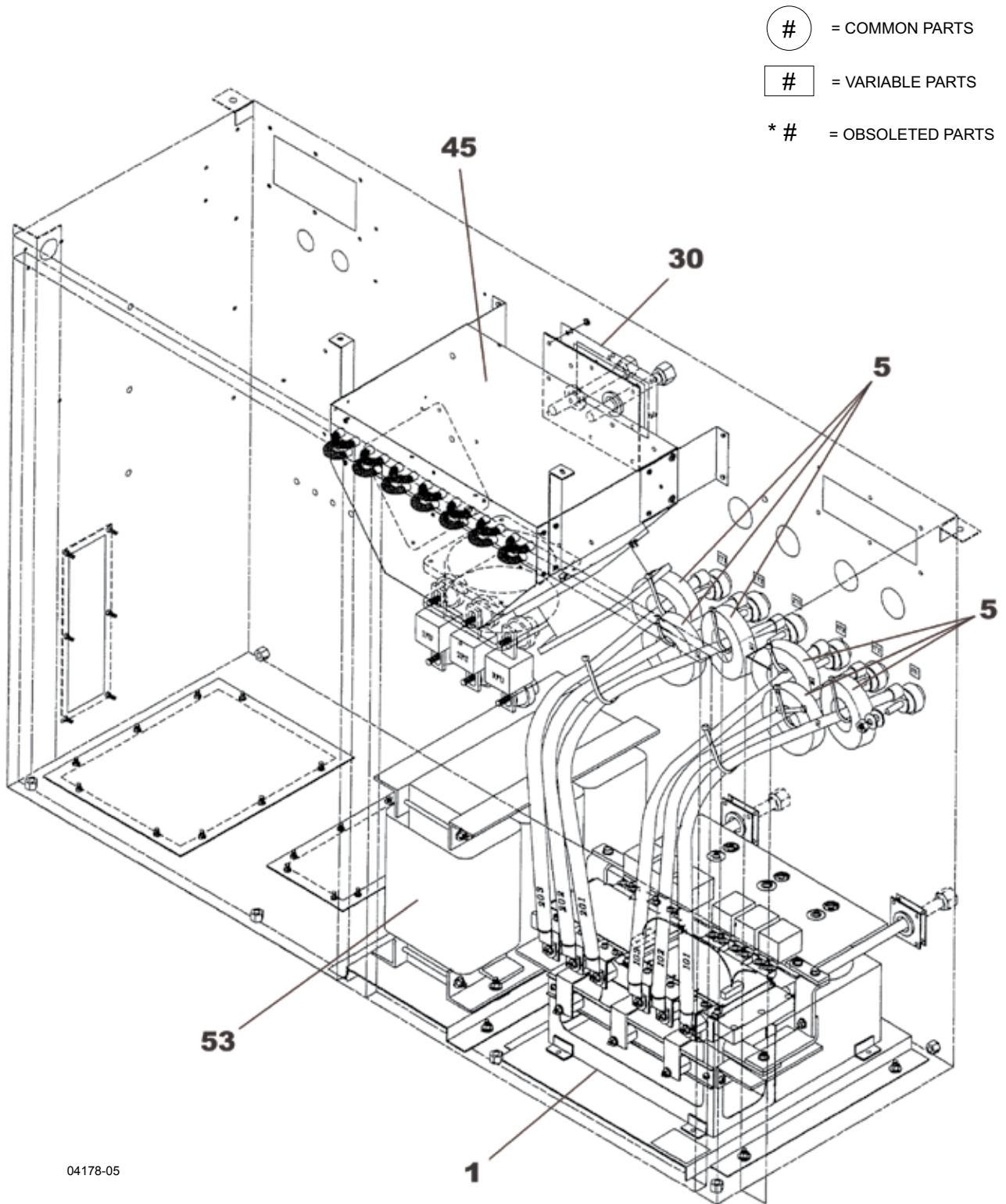

04178-05

Variable Speed Drive

**FIG. 8C** – VARIABLE SPEED DRIVE COMPONENTS (REF. 'COMMON PARTS' TABLE 7, PAGE 36 AND VARIABLE PARTS TABLE 8, PAGES 37-41)

# VARIABLE SPEED DRIVE PANEL COMPONENTS (CONT'D)

**TABLE 7 – VARIABLE SPEED DRIVE COMMON PARTS (SEE. FIGS. 8-8C, PAGES 32-35)**

ITEM NUMBER	QUANTITY PER UNIT	DESCRIPTION	YORK PART NUMBER
5	1	RELAY, PUMP / FAN	024-30441-000
7	3	TRANSFORMER, 75VA (3T, 10T, 11T)	025-27911-000
15	5	FUSE HOLDER, 1 POLE - 30A	025-39951-000
17	1	VOLTAGE SUPPRESSION BOARD	031-02453-000
20	1	RELAY BOARD #1	031-02479-001
22	12	RESISTOR (R3-R14)	025-35953-000
23	6	CAPACITOR (C13-C18)	025-39806-000
24	1	WIRING KIT, DVDT	571-04178-211
25	12	PAD, THERMAL	028-15299-000
27	1	RELAY BOARD #2	031-02479-002
28 <sup>S</sup>	1	CHILLER CONTROL BOARD	331-03478-001
28A	1	SD CARD WITH SOFTWARE (STANDARD)	031-03476-001
		SD CARD WITH SOFTWARE (OPTIMIZED)	031-03476-002
		BLANK SD CARD	031-03466-000
31	1	BUS ISOLATION BOARD	031-01624-000
32	1	GASKET, FIELD POWER	028-15246-000
33	1	GASKET, CUSTOMER CONNECTIONS	028-15247-000
34	1	GASKET, CIRCUIT BREAKER	028-15248-000
35	1	GASKET, AUTO TRANSFORMER	028-15249-000
36	1	GASKET, KEYPAD / DISPLAY	028-15250-000
37	1	GASKET, COIL	028-15251-000
59	1	EPROM, PWM GENERATOR U39	031-02522-001*
59a	1	EPROM, LOGIC BOARD U36 (obsolete)	031-02521-001**
59b	1	PROM, FPGA U41 (obsolete)	031-02523-001**
59c	1	EPROM, LOGIC BOARD U39 (obsolete)	031-02522-001**
61	1	KEYPAD, LATITUDE	024-34930-000***
	1	OVERLAY, KEYPAD (ENGLISH)	024-34930-001***
62	1	DISPLAY, LATITUDE	031-02508-000
63	1	SWITCH, ON / OFF	024-34951-000
68	1	CABLE, RIBBON (DISPLAY)	571-04178-261
69	1	CABLE, RIBBON (KEYPAD)	571-04178-262
70	1	CABLE, RIBBON (RELAY BOARD #1)	571-04178-263
72 <sup>S</sup>	1	CONTROLLER, DRAIN/FEED (90° FLOW)	031-02510-000****
	1	CONTROLLER, DRAIN/FEED (STRAIGHT FLOW)	031-02742-000****
77	1	CABLE, RIBBON (RELAY BOARD #2)	571-04178-264
88	3	FUSES (11FU, 12FU, 13FU)	025-38523-000
92	1	FUSE, 15A (18FU)	025-34141-000
93	1	FUSE, 20A (17FU)	025-35908-000
94	3	FUSE, 6A (20FU, 21FU)	025-35902-000

\* Note: Used on new 031-02507-000 VSD Logic Board.

\*\* Note: Only used on obsolete 031-02477--000 VSD Logic Board (no longer available).

\*\*\* Note: Both the keypad and overlay must be replaced when replacing the keypad.

\*\*\*\* Note: See page 20 for valve type to aid in identifying the controller.

# VARIABLE SPEED DRIVE PANEL COMPONENTS (CONT'D)

**TABLE 8 – VARIABLE SPEED DRIVE VARIABLE PARTS (SEE: FIGS. 8-8C, PAGES 32-35)**

Item Number	Description	371-04178-101*		371-04178-102*		371-04178-103*		371-04178-104*		371-04178-105*		371-04178-106*	
		Qty	Part Number	Qty	Part Number	Qty	Part Number	Qty	Part Number	Qty	Part Number	Qty	Part Number
151	Single Point Terminal Block Kit	1	371-04460-003	1	371-04460-003	1	371-04460-002	1	371-04460-002	1	371-04460-004	1	371-04460-001
152	Single Point Circuit Breaker	-	N/A	-	N/A	-	N/A	-	N/A	-	N/A	-	N/A
152A	Operator Mechanism (Shaft and Handle)	-	N/A	-	N/A	-	N/A	-	N/A	-	N/A	-	N/A
155	Microgateway Board	-	N/A	-	N/A	-	N/A	-	N/A	-	N/A	-	N/A
156	Ground Lugs	4	025-32835-000	4	025-32835-000	3	025-32835-000	3	025-32835-000	2	025-32835-000	2	025-32835-000
157	Inductor	1	025-39677-000	1	025-39677-000	1	025-39677-000	1	025-39677-000	1	025-39677-000	1	025-39677-000
166	SCR Trigger Board	1	031-02060-001	1	031-02060-001	1	031-02060-001	1	031-02060-001	1	031-02060-001	1	031-02060-001
167	Control Transformer 2T	1	025-40114-001	1	025-40114-001	1	025-40114-001	1	025-40114-001	1	025-40114-001	1	025-40114-001
169	Cooling Fan Assy	1	371-04179-502	1	371-04179-502	1	371-04179-502	1	371-04179-504	1	371-04179-502	1	371-04179-502
170	Eprom, Microgateway	-	N/A	-	N/A	-	N/A	-	N/A	-	N/A	-	N/A
171	Eprom, Logic Board (U52)	1	031-02649-001	1	031-02649-001	1	031-02649-001	1	031-02649-001	1	031-02649-001	1	031-02649-001
172	VSD Power Assembly Complete (See Page 44)	1	371-04181-101	1	371-04181-101	1	371-04181-101	1	371-04181-101	1	371-04181-101	1	371-04181-101
173	Fan Contactor	6	024-34916-000	6	024-34916-000	6	024-34916-000	6	024-34916-000	6	024-34916-000	6	024-34916-000
173A	Harness, Fan Contactor	1	571-04178-231	1	571-04178-231	1	571-04178-231	1	571-04178-231	1	571-04178-231	1	571-04178-231
175	Transformer, Current (Sys. 1) 300 : 0.1 Ratio	3	025-21173-009	3	025-21173-009	3	025-21173-009	3	025-21173-009	3	025-21173-009	3	025-21173-009
176	Transformer, Current (Sys. 2) 300 : 0.1 Ratio	3	025-21173-009	3	025-21173-009	3	025-21173-009	3	025-21173-009	3	025-21173-009	3	025-21173-009
177	Fuse Holder (3 Pole)	3	025-39952-000	3	025-39952-000	3	025-39952-000	3	025-39952-000	3	025-39952-000	3	025-39952-000
178	Fuse (1FU, 2FU, 3FU)	3	025-39681-000	3	025-39681-000	3	025-39681-000	3	025-39681-000	3	025-39681-000	3	025-39681-000
182	Fuse, 30A (7-9FU, 14-16FU)	6	025-39683-000	6	025-39683-000	6	025-39683-000	6	025-39683-000	6	025-39683-000	6	025-39683-000
183	Fuse, 10A (4FU, 5FU, 19FU)	3	031-35905-000	3	031-35905-000	3	031-35905-000	3	031-35905-000	3	031-35905-000	3	031-35905-000
190	VSD Logic Board*	1	031-02507-000	1	031-02507-000	1	031-02507-000	1	031-02507-000	1	031-02507-000	1	031-02507-000
190A	VSD Logic Board (Obsolete)**	1	031-02477-000	1	031-02477-000	1	031-02477-000	1	031-02477-000	1	031-02477-000	1	031-02477-000

\* Note: Must order VSD Logic Board Kit (331-02507-601) when replacing Logic Board (Kit includes EPROMs and PWM Generator - 59 & 171).

\*\* Note: Must order VSD Logic Board Kit (331-02507-601) when replacing Logic Board (Kit includes EPROMs and PWM Generator - 59a, 59b & 59c).

**Service Note:**

Locate the PANEL NUMBER nameplate on the lower right hand outside corner of the power panel, then refer to the appropriate parts list for that number. Or, identify P/N number positions 16 and 17 on unit identification plate (See example on Page 4) then compare to table above for power configuration options.



# VARIABLE SPEED DRIVE PANEL COMPONENTS (CONT'D)

## Variable Speed Drive

**TABLE 8 (CONT'D) – VARIABLE SPEED DRIVE VARIABLE PARTS (SEE FIGS. 8-8C, PAGES 32-35)**

Item Number	Description	371-04178-107*		371-04178-108*		371-04178-109*		371-04178-110*		371-04178-111*		371-04178-112*	
		Qty	Part Number	Qty	Part Number	Qty	Part Number	Qty	Part Number	Qty	Part Number	Qty	Part Number
151	Single Point Terminal Block Kit	-	N/A	-	N/A	-	N/A	-	N/A	-	N/A	-	N/A
152	Single Point Circuit Breaker	1	224-34968-001	1	224-34968-001	1	224-34966-001	1	224-34966-001	1	224-34965-001	1	224-34965-001
152A	Operator Mechanism (Shaft and Handle)	1	024-34922-000	1	024-34922-000	1	024-34922-000	1	024-34922-000	1	024-34922-000	1	024-34922-000
155	Microgateway Board	-	N/A	-	N/A	-	N/A	-	N/A	-	N/A	-	N/A
156	Ground Lugs	4	025-32835-000	4	025-32835-000	3	025-32835-000	3	025-32835-000	2	025-32835-000	2	025-32835-000
157	Inductor	1	025-39677-000	1	025-39677-000	1	025-39677-000	1	025-39677-000	1	025-39677-000	1	025-39677-000
166	SCR Trigger Board	1	031-02060-001	1	031-02060-001	1	031-02060-001	1	031-02060-001	1	031-02060-001	1	031-02060-001
167	Control Transformer 2T	1	025-40114-001	1	025-40114-001	1	025-40114-001	1	025-40114-001	1	025-40114-001	1	025-40114-001
169	Cooling Fan Assy	1	371-04179-502	1	371-04179-502	1	371-04179-502	1	371-04179-502	1	371-04179-502	1	371-04179-502
170	Eprom, Microgateway	-	N/A	-	N/A	-	N/A	-	N/A	-	N/A	-	N/A
171	Eprom, Logic Board (U52)	1	031-02649-001	1	031-02649-001	1	031-02649-001	1	031-02649-001	1	031-02649-001	1	031-02649-001
172	VSD Power Assembly Complete (See Page 44)	1	371-04181-101	1	371-04181-101	1	371-04181-101	1	371-04181-101	1	371-04181-101	1	371-04181-101
173	Fan Contactor	6	024-34916-000	6	024-34916-000	6	024-34916-000	6	024-34916-000	6	024-34916-000	6	024-34916-000
173A	Harness, Fan Contactor	1	571-04178-231	1	571-04178-231	1	571-04178-231	1	571-04178-231	1	571-04178-231	1	571-04178-231
175	Transformer, Current (Sys. 1) 300 : 0.1 Ratio	3	025-21173-009	3	025-21173-009	3	025-21173-009	3	025-21173-009	3	025-21173-009	3	025-21173-009
176	Transformer, Current (Sys. 2) 300 : 0.1 Ratio	3	025-21173-009	3	025-21173-009	3	025-21173-009	3	025-21173-009	3	025-21173-009	3	025-21173-009
177	Fuse Holder (3 Pole)	3	025-39952-000	3	025-39952-000	3	025-39952-000	3	025-39952-000	3	025-39952-000	3	025-39952-000
178	Fuse (1FU, 2FU, 3FU)	3	025-39681-000	3	025-39681-000	3	025-39681-000	3	025-39681-000	3	025-39681-000	3	025-39681-000
182	Fuse, 30A (7-9FU, 14-16FU)	6	025-39683-000	6	025-39683-000	6	025-39683-000	6	025-39683-000	6	025-39683-000	6	025-39683-000
183	Fuse, 10A (4FU, 5FU, 19FU)	3	031-35905-000	3	031-35905-000	3	031-35905-000	3	031-35905-000	3	031-35905-000	3	031-35905-000
190	VSD Logic Board*	1	031-02507-000	1	031-02507-000	1	031-02507-000	1	031-02507-000	1	031-02507-000	1	031-02507-000
190A	VSD Logic Board (Obsolete)**	1	031-02477-000	1	031-02477-000	1	031-02477-000	1	031-02477-000	1	031-02477-000	1	031-02477-000

\* Note: Must order VSD Logic Board Kit (331-02507-601) when replacing Logic Board (Kit includes EPROMs and PWM Generator - 59 & 171).

\*\* Note: Must order VSD Logic Board Kit (331-02507-601) when replacing Logic Board (Kit includes EPROMs and PWM Generator - 59a, 59b & 59c).

**Service Note:**

Locate the PANEL NUMBER nameplate on the lower right hand outside corner of the power panel, then refer to the appropriate parts list for that number. Or, identify PIN number positions 16 and 17 on unit identification plate (See example on Page 4) then compare table above for power configuration options.

# VARIABLE SPEED DRIVE PANEL COMPONENTS (CONT'D)

**TABLE 8 – VARIABLE SPEED DRIVE VARIABLE PARTS (SEE: FIGS. 8-8C, PAGES 32-35)**

Item Number	Description	371-04178-113*		371-04178-114*		371-04178-115*		371-04178-116*		371-04178-117*		371-04178-118*	
		Qty	Part Number	Qty	Part Number	Qty	Part Number	Qty	Part Number	Qty	Part Number	Qty	Part Number
151	Single Point Terminal Block Kit	1	371-04460-003	1	371-04460-003	1	371-04460-002	1	371-04460-002	1	371-04460-004	1	371-04460-001
152	Single Point Circuit Breaker	-	N/A	-	N/A	-	N/A	-	N/A	-	N/A	-	N/A
152A	Operator Mechanism (Shaft and Handle)	-	N/A	-	N/A	-	N/A	-	N/A	-	N/A	-	N/A
155	Microgateway Board	1	031-02039-000	1	031-02039-000	1	031-02039-000	1	031-02039-000	1	031-02039-000	1	031-02039-000
156	Ground Lugs	4	025-32835-000	4	025-32835-000	3	025-32835-000	3	025-32835-000	2	025-32835-000	2	025-32835-000
157	Inductor	1	025-39677-000	1	025-39677-000	1	025-39677-000	1	025-39677-000	1	025-39677-000	1	025-39677-000
166	SCR Trigger Board	1	031-02060-001	1	031-02060-001	1	031-02060-001	1	031-02060-001	1	031-02060-001	1	031-02060-001
167	Control Transformer 2T	1	025-40114-001	1	025-40114-001	1	025-40114-001	1	025-40114-001	1	025-40114-001	1	025-40114-001
169	Cooling Fan Assy	1	371-04179-502	1	371-04179-502	1	371-04179-502	1	371-04179-504	1	371-04179-502	1	371-04179-502
170	Eprom, Microgateway	1	031-02200-005	1	031-02200-005	1	031-02200-005	1	031-02200-005	1	031-02200-005	1	031-02200-005
171	Eprom, Logic Board (U52)	1	031-02649-001	1	031-02649-001	1	031-02649-001	1	031-02649-001	1	031-02649-001	1	031-02649-001
172	VSD Power Assembly Complete (See Page 44)	1	371-04181-101	1	371-04181-101	1	371-04181-101	1	371-04181-101	1	371-04181-101	1	371-04181-101
173	Fan Contactor (3 Pole)	6	024-34916-000	6	024-34916-000	6	024-34916-000	6	024-34916-000	6	024-34916-000	6	024-34916-000
173A	Harness, Fan Contactor	1	571-04178-231	1	571-04178-231	1	571-04178-231	1	571-04178-231	1	571-04178-231	1	571-04178-231
175	Transformer, Current (Sys. 1) 300 : 0.1 Ratio	3	025-21173-009	3	025-21173-009	3	025-21173-009	3	025-21173-009	3	025-21173-009	3	025-21173-009
176	Transformer, Current (Sys. 2) 300 : 0.1 Ratio	3	025-21173-009	3	025-21173-009	3	025-21173-009	3	025-21173-009	3	025-21173-009	3	025-21173-009
177	Fuse Holder (3 Pole)	3	025-39952-000	3	025-39952-000	3	025-39952-000	3	025-39952-000	3	025-39952-000	3	025-39952-000
178	Fuse (1FU, 2FU, 3FU)	3	025-39681-000	3	025-39681-000	3	025-39681-000	3	025-39681-000	3	025-39681-000	3	025-39681-000
182	Fuse, 30A (7-9FU, 14-16FU)	6	025-39683-000	6	025-39683-000	6	025-39683-000	6	025-39683-000	6	025-39683-000	6	025-39683-000
183	Fuse, 10A (4FU, 5FU, 19FU)	3	031-35905-000	3	031-35905-000	3	031-35905-000	3	031-35905-000	3	031-35905-000	3	031-35905-000
190	VSD Logic Board*	1	031-02507-000	1	031-02507-000	1	031-02507-000	1	031-02507-000	1	031-02507-000	1	031-02507-000
190A	VSD Logic Board (Obsolete)**	1	031-02477-000	1	031-02477-000	1	031-02477-000	1	031-02477-000	1	031-02477-000	1	031-02477-000

\* Note: Must order VSD Logic Board Kit (331-02507-601) when replacing Logic Board (Kit includes EPROMs and PWM Generator - 59 & 171).

\*\* Note: Must order VSD Logic Board Kit (331-02507-601) when replacing Logic Board (Kit includes EPROMs and PWM Generator - 59a, 59b & 59c).

**Service Note:**

Locate the PANEL NUMBER nameplate on the lower right hand outside corner of the power panel, then refer to the appropriate parts list for that number. Or, identify PIN number positions 16 and 17 on unit identification plate (See example on Page 4) then compare to table above for power configuration options.



# VARIABLE SPEED DRIVE PANEL COMPONENTS (CONT'D)

## Variable Speed Drive

**TABLE 8 (CONT'D) – VARIABLE SPEED DRIVE VARIABLE PARTS (SEE FIGS. 8-8C, PAGES 32-35)**

Item Number	Description	371-04178-119*		371-04178-120*		371-04178-121*		371-04178-122*		371-04178-123*		371-04178-124*	
		Qty	Part Number	Qty	Part Number	Qty	Part Number	Qty	Part Number	Qty	Part Number	Qty	Part Number
151	Single Point Terminal Block Kit	-	N/A	-	N/A	-	N/A	-	N/A	-	N/A	-	N/A
152	Single Point Circuit Breaker	1	224-34968-001	1	224-34968-001	1	224-34966-001	1	224-34966-001	1	224-34965-001	1	224-34965-001
152A	Operator Mechanism (Shaft and Handle)	1	024-34922-000	1	024-34922-000	1	024-34922-000	1	024-34922-000	1	024-34922-000	1	024-34922-000
155	Microgateway Board	1	031-02039-000	1	031-02039-000	1	031-02039-000	1	031-02039-000	1	031-02039-000	1	031-02039-000
156	Ground Lugs	4	025-32835-000	4	025-32835-000	3	025-32835-000	3	025-32835-000	2	025-32835-000	2	025-32835-000
157	Inductor	1	025-39677-000	1	025-39677-000	1	025-39677-000	1	025-39677-000	1	025-39677-000	1	025-39677-000
166	SCR Trigger Board	1	031-02060-001	1	031-02060-001	1	031-02060-001	1	031-02060-002	1	031-02060-001	1	031-02060-001
167	Control Transformer 2T	1	025-40114-001	1	025-40114-001	1	025-40114-001	1	025-40114-002	1	025-40114-001	1	025-40114-001
169	Cooling Fan Assy	1	371-04179-502	1	371-04179-502	1	371-04179-502	1	371-04179-504	1	371-04179-502	1	371-04179-502
170	Eprom, Microgateway	1	031-02200-005	1	031-02200-005	1	031-02200-005	1	031-02200-005	1	031-02200-005	1	031-02200-005
171	Eprom, Logic Board (U52)	1	031-02649-001	1	031-02649-001	1	031-02649-001	1	031-02649-001	1	031-02649-001	1	031-02649-001
172	VSD Power Assembly Complete (See Page 44)	1	371-04181-101	1	371-04181-101	1	371-04181-101	1	371-04181-101	1	371-04181-101	1	371-04181-101
173	Fan Contactor	6	024-34916-000	6	024-34916-000	6	024-34916-000	6	024-34916-000	6	024-34916-000	6	024-34916-000
173A	Harness, Fan Contactor	1	571-04178-231	1	571-04178-231	1	571-04178-231	1	571-04178-231	1	571-04178-231	1	571-04178-231
175	Transformer, Current (Sys. 1) 300 : 0.1 Ratio	3	025-21173-009	3	025-21173-009	3	025-21173-009	3	025-21173-009	3	025-21173-009	3	025-21173-009
176	Transformer, Current (Sys. 2) 300 : 0.1 Ratio	3	025-21173-009	3	025-21173-009	3	025-21173-009	3	025-21173-009	3	025-21173-009	3	025-21173-009
177	Fuse Holder (3 Pole)	3	025-39952-000	3	025-39952-000	3	025-39952-000	3	025-39952-000	3	025-39952-000	3	025-39952-000
178	Fuse (1FU, 2FU, 3FU)	3	025-39681-000	3	025-39681-000	3	025-39681-000	3	025-39681-000	3	025-39681-000	3	025-39681-000
182	Fuse, 30A (7-9FU, 14-16FU)	6	025-39683-000	6	025-39683-000	6	025-39683-000	6	025-39683-000	6	025-39683-000	6	025-39683-000
183	Fuse, 10A (4FU, 5FU, 19FU)	3	031-35905-000	3	031-35905-000	3	031-35905-000	3	031-35905-000	3	031-35905-000	3	031-35905-000
190	VSD Logic Board*	1	031-02507-000	1	031-02507-000	1	031-02507-000	1	031-02507-000	1	031-02507-000	1	031-02507-000
190A	VSD Logic Board (Obsolete)**	1	031-02477-000	1	031-02477-000	1	031-02477-000	1	031-02477-000	1	031-02477-000	1	031-02477-000

\* Note: Must order VSD Logic Board Kit (331-02507-601) when replacing Logic Board (Kit includes EPROMs and PWM Generator - 59 & 171).

\*\* Note: Must order VSD Logic Board Kit (331-02507-601) when replacing Logic Board (Kit includes EPROMs and PWM Generator - 59a, 59b & 59c).

**Service Note:**

Locate the PANEL NUMBER nameplate on the lower right hand outside corner of the power panel, then refer to the appropriate parts list for that number. Or, identify PIN number positions 16 and 17 on unit identification plate (See example on Page 4) then compare to table above for power configuration options.

*This page intentionally left blank*

# VARIABLE SPEED DRIVE PANEL COMPONENTS (CONT'D)



AUTOTRANSFORMER

**TABLE 9a – AUTOTRANSFORMER**

VOLTAGE CODE	QUANTITY PER UNIT	YORK PART NUMBER
17	1	371-55898-001
28	1	371-55898-002
40	1	371-55898-003
46	1	Not Required
50	1	371-55898-004
58	1	371-55898-005

# VARIABLE SPEED DRIVE PANEL COMPONENTS (CONT'D)

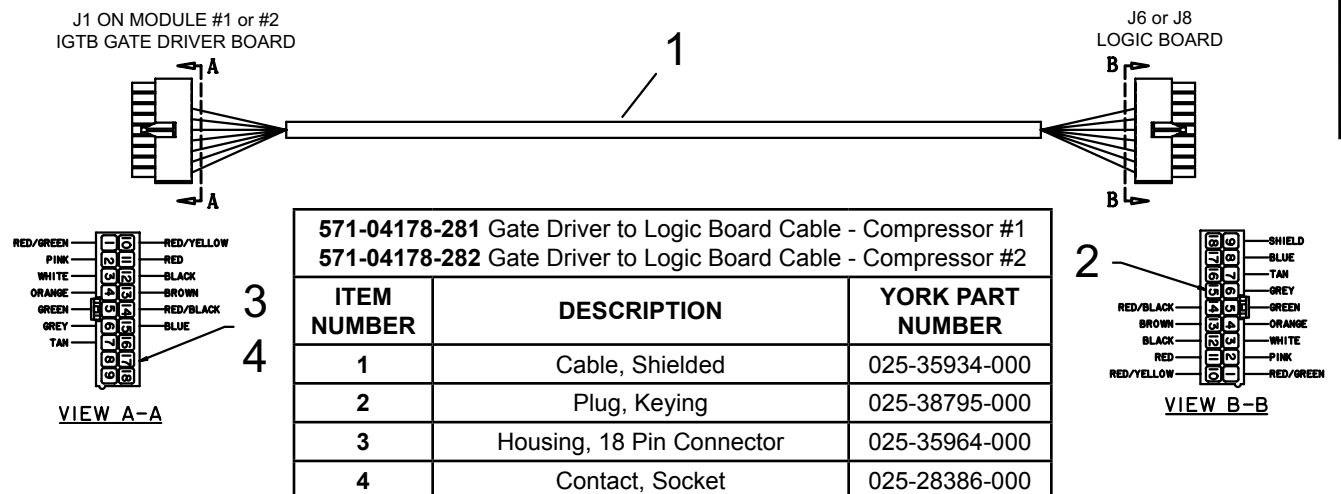
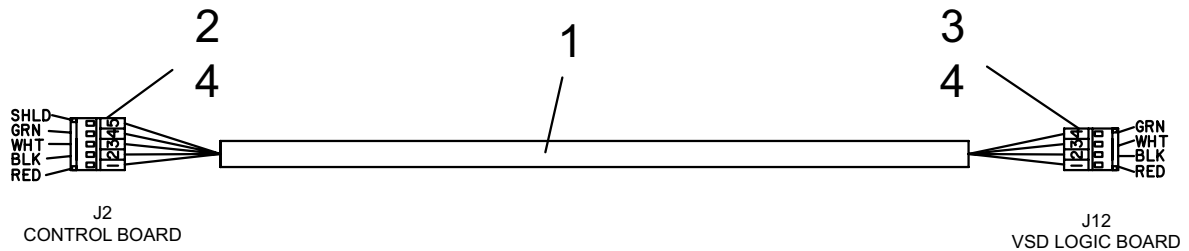
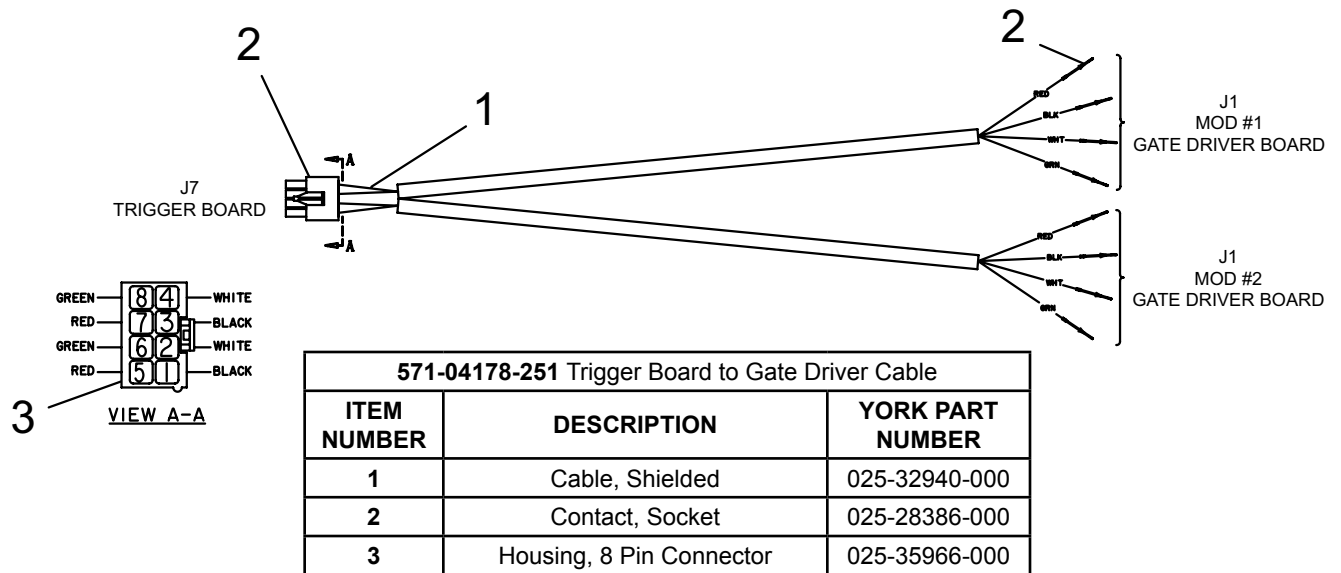

Variable Speed Drive

FIG. 8E – CABLE PART NUMBERS

# VARIABLE SPEED DRIVE POWER ASSEMBLY COMPONENTS

\*Note: For complete VSD Power Assembly Replacement Kit use 371-04181-401. VSD Power Assembly Replacement Kit includes all necessary items including Glycol.

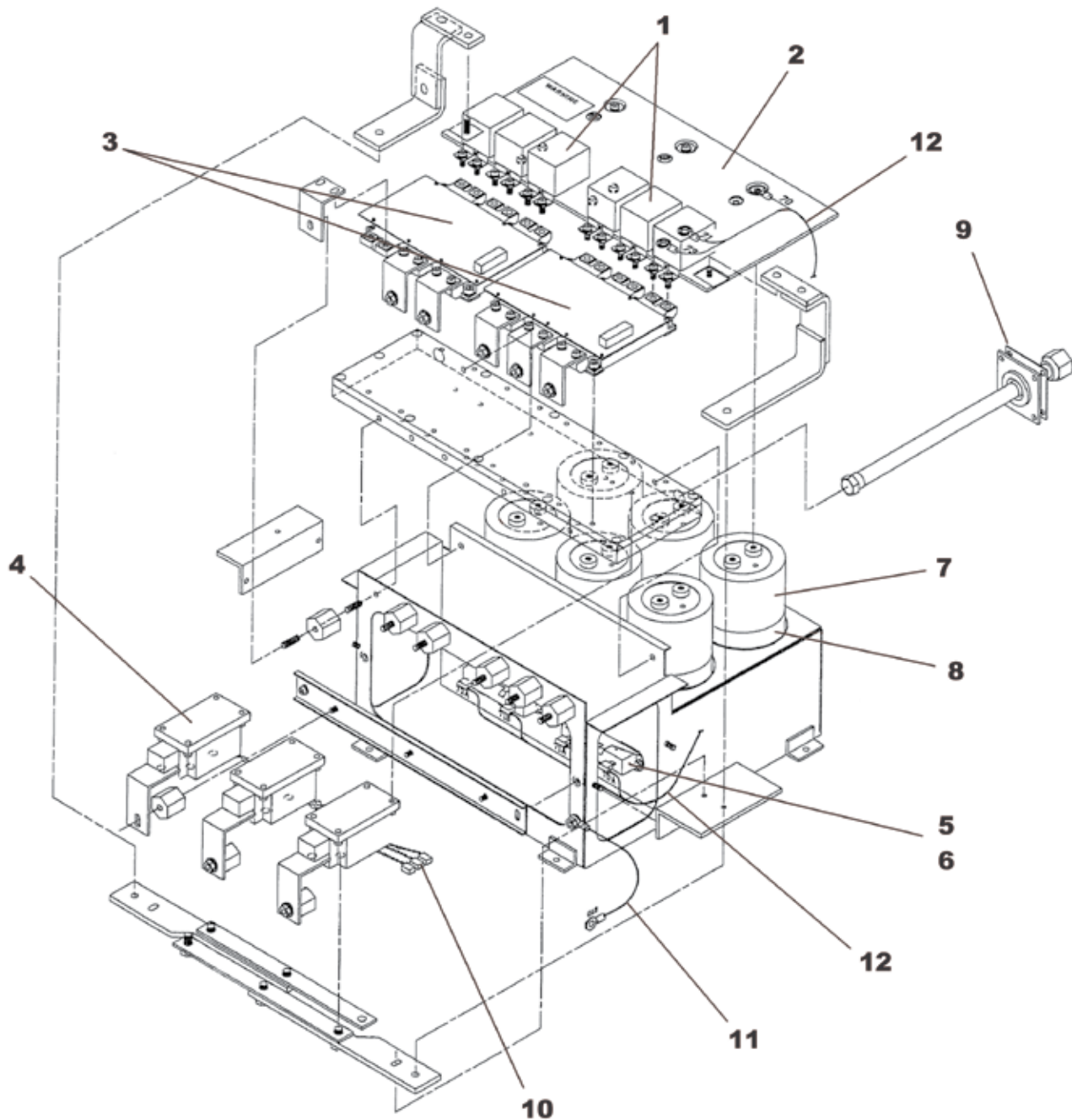

**FIG. 9 – VARIABLE SPEED DRIVE POWER ASSEMBLY COMPONENTS**  
(REF. TABLE 10, PAGE 45)

## VARIABLE SPEED DRIVE POWER ASSEMBLY COMPONENTS (CONT'D)

**TABLE 10** – VARIABLE SPEED DRIVE POWER ASSEMBLY COMPONENTS  
(SEE FIG. 9, PAGE 44)

ITEM NUMBER	QUANTITY PER UNIT	DESCRIPTION	YORK PART NUMBER
1	6	CAPACITOR (IGBT SNUBBER)	025-35972-000
2	1	BUSS PLATE KIT	371-04477-001
3	2	IGBT ASSEMBLY REPLACEMENT KIT*	371-04479-001
4	3	SCR/DIODE MODULE REPLACEMENT KIT	371-04478-001
5	2	RESISTOR	025-35157-000
6	2	THERMAL PAD	028-15299-000
7	6	CAPACITOR (BUSS)	025-35973-000
8	6	INSULATOR, CAPACITOR	071-02769-319
9	2	GASKET	028-15113-000
10	1	HARNESS, SCR TO TRIGGER BD.	571-04181-221
11	1	HARNESS, GROUND	571-04181-242
12	1	HARNESS, EQUALIZER	571-04181-241

\*Note: Includes IGBT Gate Driver and IGBT Module as an assembly. DO NOT attempt to replace the IGBT Gate Driver or the IGBT Module individually.

# VARIABLE SPEED DRIVE COOLING FAN ASSEMBLY COMPONENTS

TABLE 11 – VARIABLE SPEED DRIVE FAN ASSEMBLY COMPONENTS (SEE FIG. 10)

ITEM NUMBER	QUANTITY PER UNIT	DESCRIPTION	YORK PART NUMBER
1	1	COIL, GLYCOL COOLING	026-41590-000
2	2	FAN, COOLING 115V	025-40105-000
3	1	HARNESS, FAN ASSEMBLY	571-04179-242
4	2	TERMINAL BLOCK	025-20944-000
5	1	INVERTER (50HZ ONLY)	031-02533-000
6	AR	COMPOUND, HEAT CONDUCTIVE (USE WITH ITEM #5)	013-02997-000
7	1	HARNESS, INVERTER (50HZ ONLY)	571-04179-243
8	2	GROMMET	028-04873-000

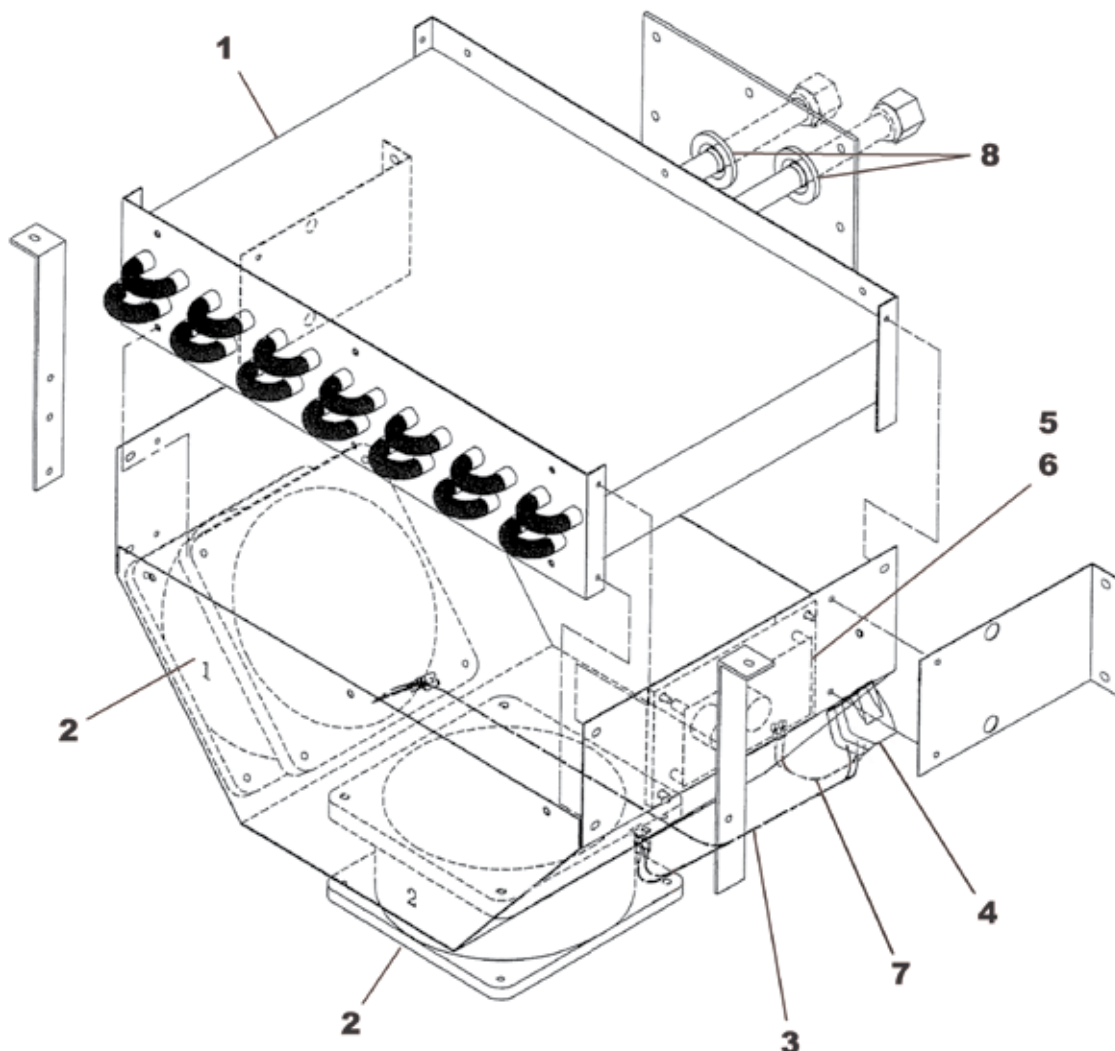

04179-5a

FIG. 10 – VARIABLE SPEED DRIVE FAN ASSEMBLY COMPONENTS (REF. TABLE 11)

# PLUG / JUMPER ARRANGEMENT

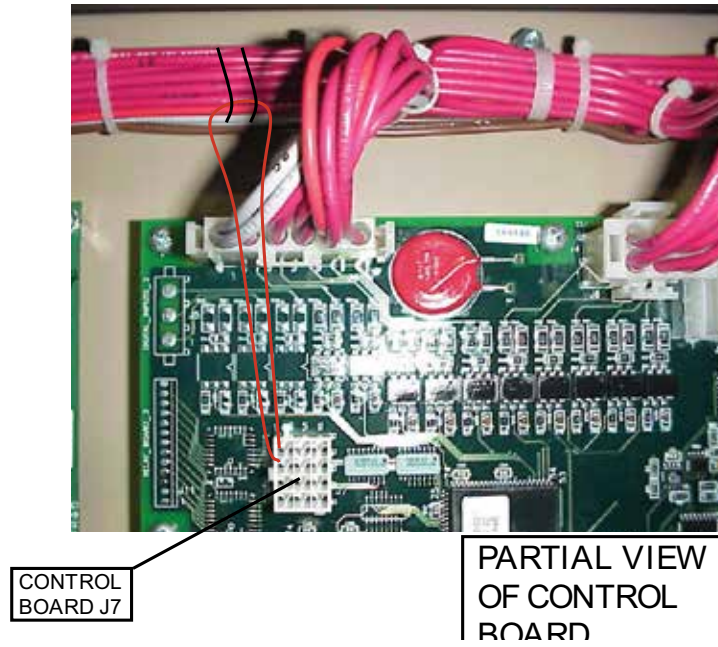

**FIG. 11 – PLUG / JUMPER ARRANGEMENT (REF. TABLE 12)**

**TABLE 12 – PLUG / JUMPER ARRANGEMENT (SEE FIG. 11)**

PLUG / JUMPER ARRANGEMENT			
PLUG P/N	JUMPER DETAIL	MODELS 60HZ	MAX VSD FREQUENCY
371-04484-101		YCAV0177SA/PA YCAV0197EA/VA YCAV0269EA/VA	182
371-04484-102		YCAV0157EA/VA YCAV0207SA/PA	186
371-04484-103		YCAV0187EA/VA YCAV0207EA/VA	192
371-04484-104		YCAV0157SA/PA YCAV0177EA/VA YCAV0187SA/PA YCAV0177SA/PA YCAV0227EA/VA YCAV0247SA/PA YCAV0247EA/VA YCAV0267SA/PA	200

Variable Speed Drive

# SENSOR HARNESSSES

55632-000D

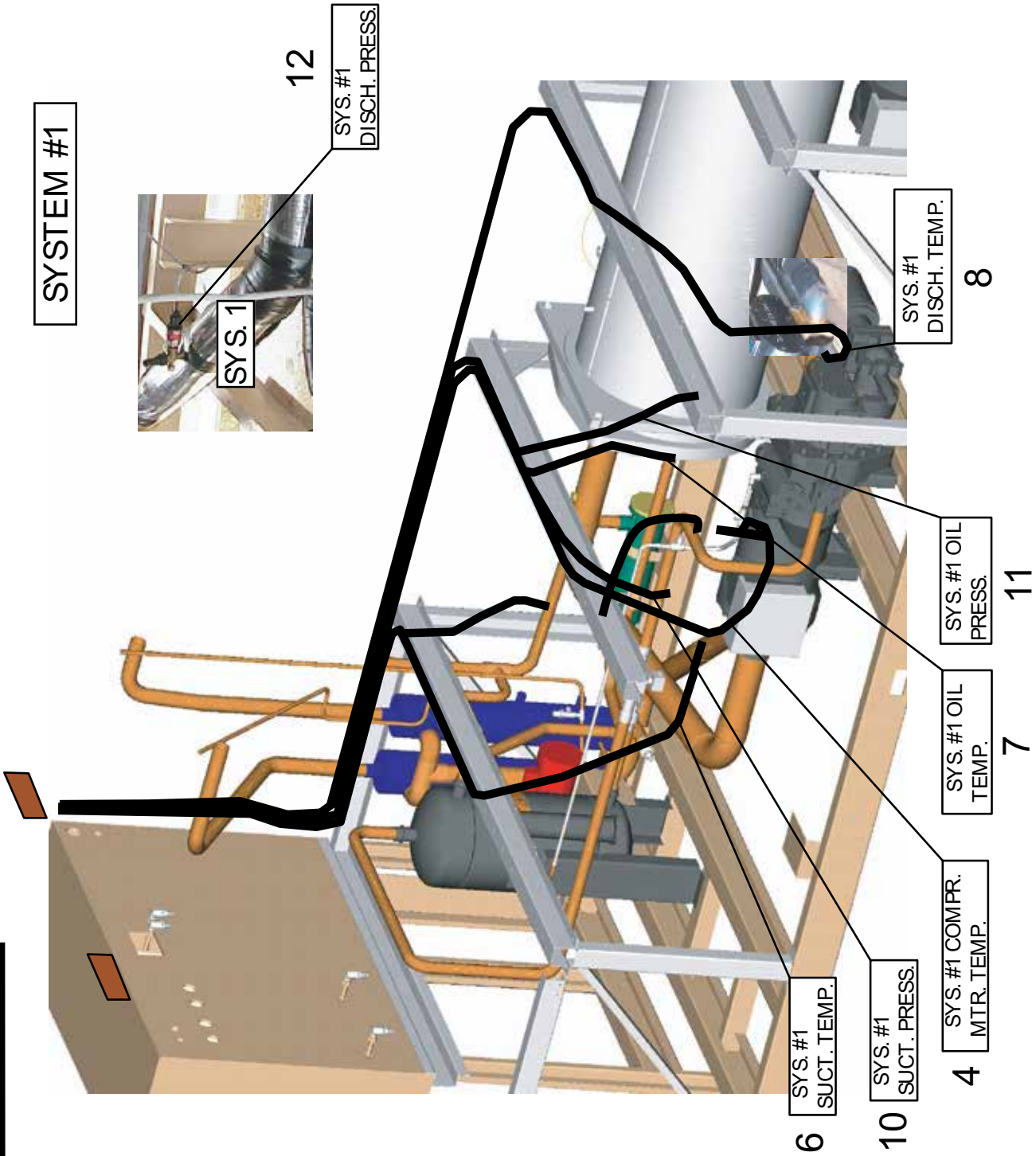

**FIG. 12** – HARNESS LAYOUT (REF. TABLE 13, PAGES 52, 53 AND 54)

# SENSOR HARNESES (CONT'D)

55832-000G

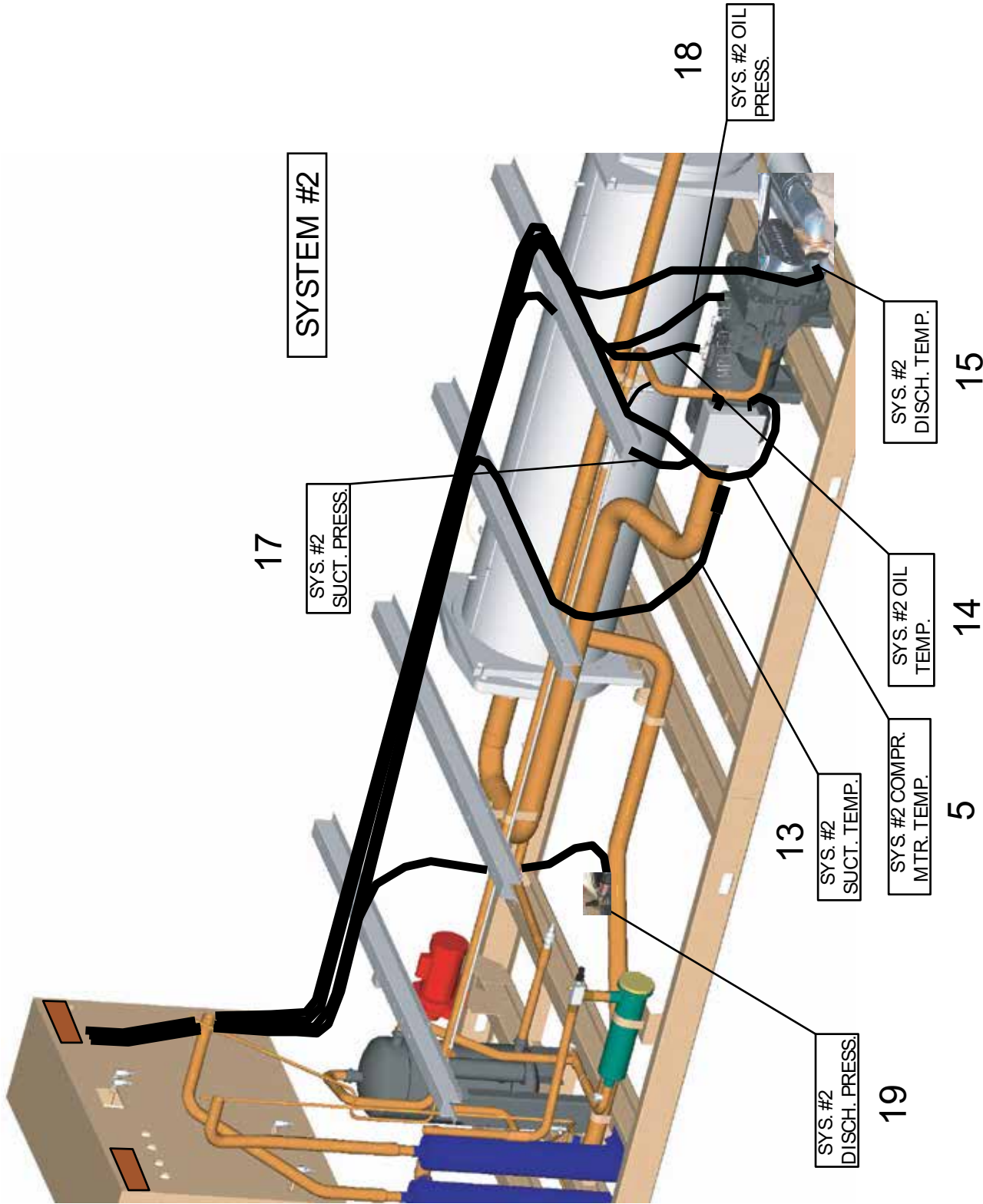
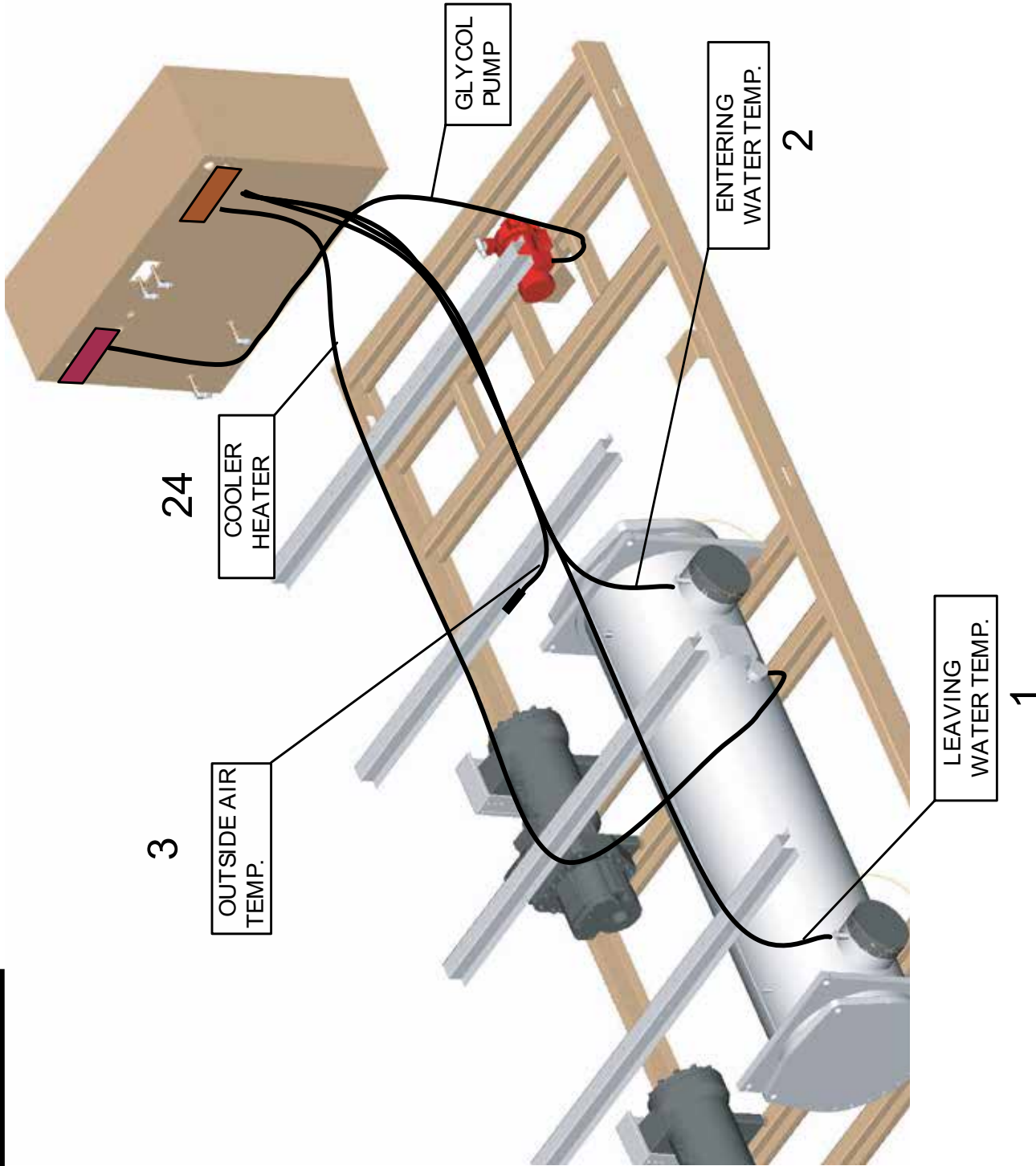

FIG. 12A – HARNESS LAYOUT (REF. TABLE 13, PAGES 52, 53 AND 54)

## Sensor Harnesses

# SENSOR HARNESSES (CONT'D)

55832-000A



**FIG. 12B** – HARNESS LAYOUT (REF. TABLE 13, PAGES 52, 53 AND 54)

# SENSOR HARNESSSES (CONT'D)

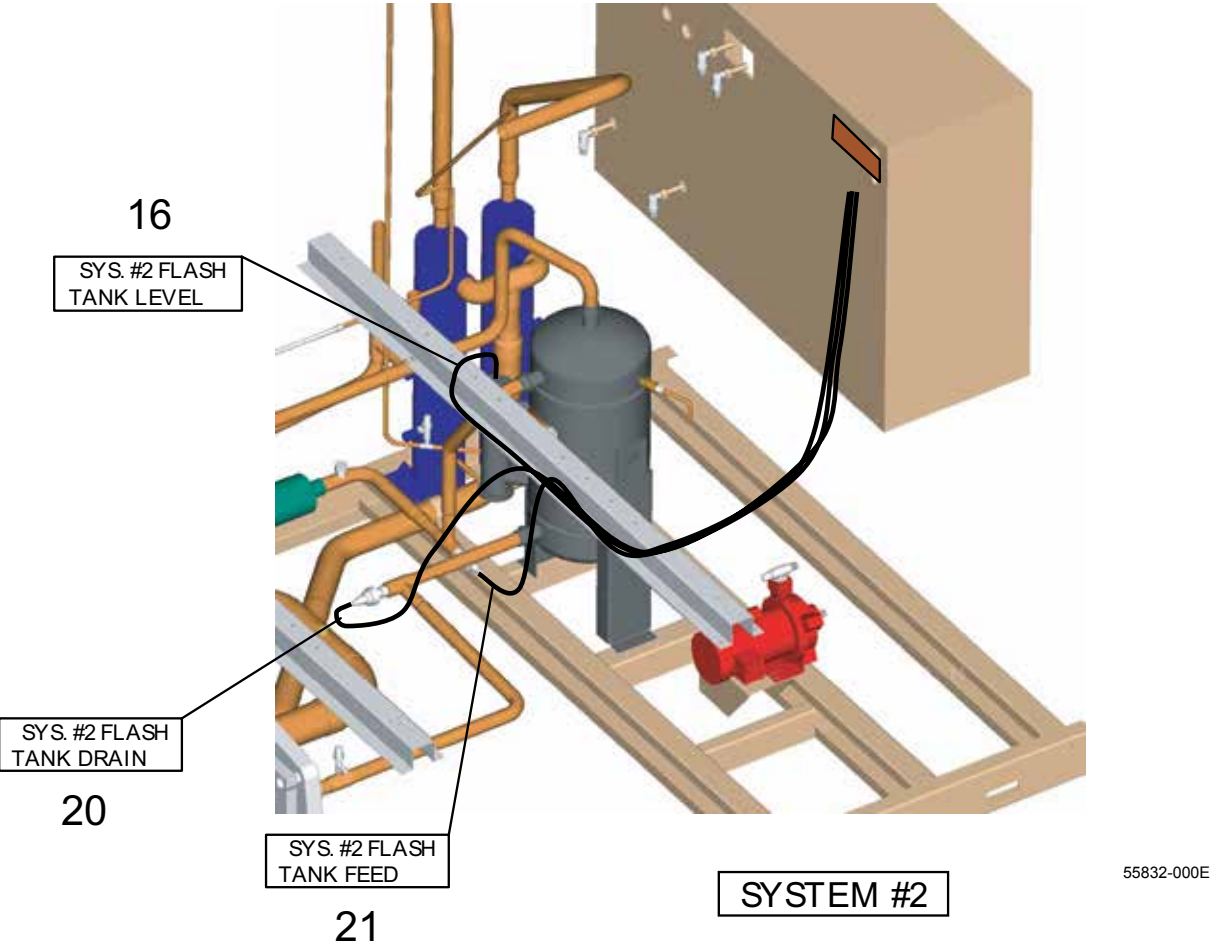
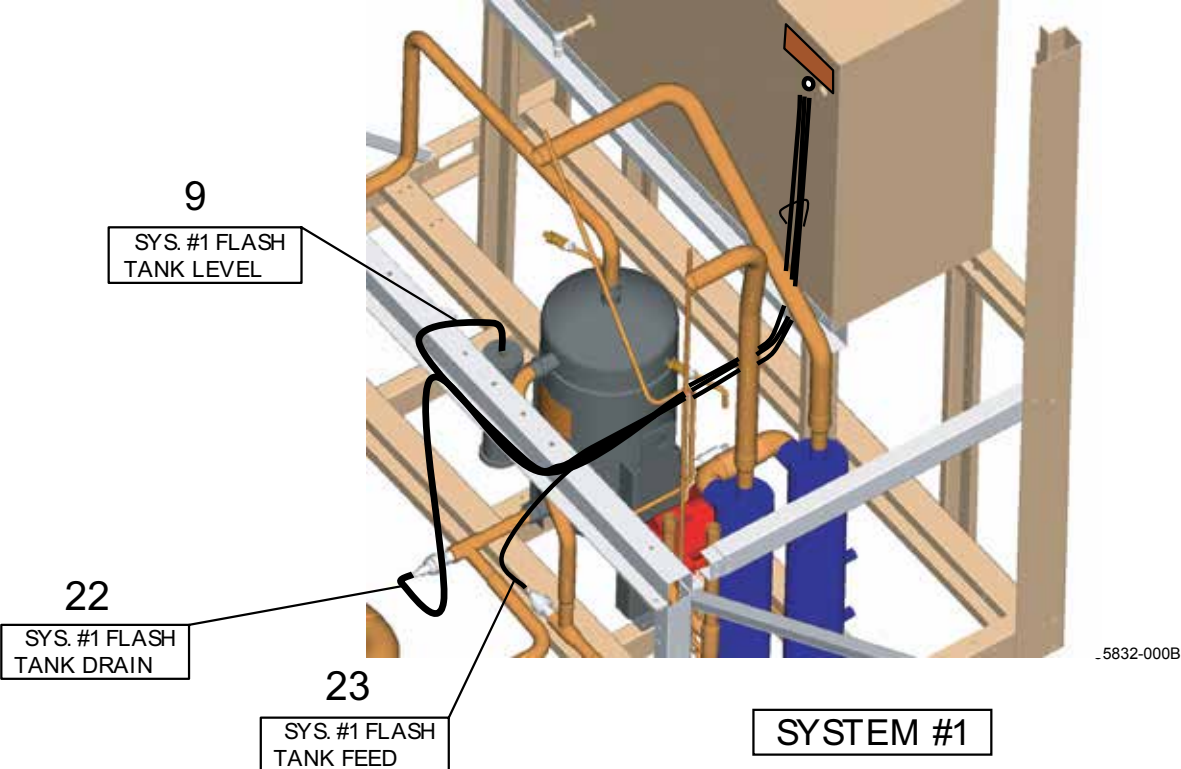

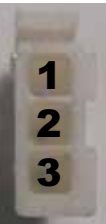

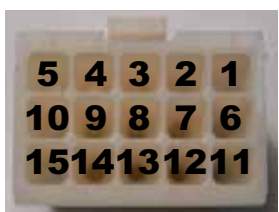

FIG. 12C – HARNESS LAYOUT (REF. TABLE 13, PAGES 52, 53 AND 54)



## SENSOR HARNESSSES (CONT'D)

**TABLE 13 – SENSOR HARNESS WIRING (SEE FIGS. 12, 12A, 12B AND 12C, PAGES 48, 49, 50 AND 51)**

SYSTEM #1 SENSOR WIRING							
Plug Detail	Plug and Pin P/N	Plug "P" No.	Plug Pin No.	Wire Color	Cable #	Function	Harness Assembly Part Number
	Plug = 025-28383-000  Pin = 025-28386-000	P26	1	Green	4	System #1 Compressor Motor Temperature	575-54455-317
			2	Red			
			3	Black			
			4	White			
			5	Drain	9	System #1 Flash Tank Level	
			6	White			
			7	Red			
			8	Black			
			9	Drain			
	Plug = 025-29185-000  Pin = 025-28386-000	P27	1	Black	6	System #1 Suction Temperature	575-54455-308
			2	Red			
			3	Drain			
	Plug = 025-28384-000  Pin = 025-28386-000	P28	1	Black	8	System #1 Discharge Temperature	575-54455-310
			2	Red			
			3	Drain			
			5	Green	22	System #1 Flash Tank Drain	
			6	Red			
			7	Black			
			8	White	23	System #1 Flash Tank Feed	
			9	Green			
			10	Red			
			11	Black			
			12	White			
				Plug = 025-28385-000  Pin = 025-28386-000	P29	1	
2	Red						
3	Black						
4	Drain						
6	White	11				System #1 Oil Pressure	
7	Red						
8	Black						
9	Drain	12				System #1 Discharge Pressure	
11	White						
12	Red						
13	Black						
14	Drain	7				System #1 Oil Temperature	
5	Black						
10	Red						
15	Drain						

## SENSOR HARNESSES (CONT'D)

**TABLE 13 (CONT'D) – SENSOR HARNESS WIRING (SEE FIGS. 12, 12A, 12B AND 12C, PAGES 48, 49, 50 AND 51)**

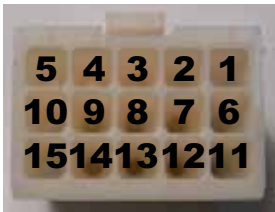
SYSTEM #2 SENSOR WIRING											
Plug Detail	Plug and Pin P/N	Plug "P" No.	Plug Pin No.	Wire Color	Cable #	Function	Harness Assembly Part Number				
	Plug = 025-28383-001  Pin = 025-28386-000	P30	1	Green	5	System #2 Compressor Motor Temperature	575-54455-318				
			2	Red							
			3	Black							
			4	White							
			5	Drain							
			P30	P30	P30	6		White	16	System #2 Flash Tank Level	575-54455-316
						7		Red			
						8		Black			
						9		Drain			
	Plug = 025-29185-001  Pin = 025-28386-000	P31	1	Black	13	System #2 Suction Temperature	575-54455-309				
			2	Red							
			3	Drain							
	Plug = 025-28384-001  Pin = 025-28386-000	P32	1	Black	15	System #2 Discharge Temperature	575-54455-311				
			2	Red							
			3	Drain							
			P32	P32	P32	5		Green	20	System #2 Flash Tank Drain	575-54455-321
						6		Red			
						7		Black			
						8		White			
						9		Green			
						10		Red			
			P32	P32	P32	11		Black	21	System #2 Flash Tank Feed	575-54455-322
						12		White			
	Plug = 025-28385-001  Pin = 025-28386-000	P33	1	White	17	System #2 Suction Pressure	575-54455-303				
			2	Red							
			3	Black							
			4	Drain							
			P33	P33	P33	6		White	18	System #2 Oil Pressure	575-54455-305
						7		Red			
						8		Black			
						9		Drain			
			P33	P33	P33	11		White	19	System #2 Discharge Pressure	575-54455-307
						12		Red			
						13		Black			
						14		Drain			
P33	P33	P33	5	Black	14	System #2 Oil Temperature	575-54455-301				
			10	Red							
			15	Drain							

## SENSOR HARNESSSES (CONT'D)

**TABLE 13 (CONT'D) – SENSOR HARNESS WIRING (SEE FIGS. 12, 12A, 12B AND 12C, PAGES 48, 49, 50 AND 51)**

UNIT SENSOR WIRING										
Plug Detail	Plug and Pin P/N	Plug "P" No.	Plug Pin No.	Wire Color	Cable #	Function	Harness Assembly Part Number			
	Plug = 025-21192-000  Pin = 025-19673-000	P25	1	Black	1	Leaving Water Temperature	575-54455-312			
			2	Red						
			3	Drain						
						4	Black	2	Entering Water Temperature	575-54455-313
						5	Red			
						6	Drain			
						7	Black	3	Outside Air Temperature	575-54455-314
						8	Red			
						9	Drain			

UNIT CONTROL WIRING							
Plug Detail	Plug and Pin P/N	Plug "P" No.	Plug Pin No.	Wire Number	Cable #	Function	Harness Assembly Part Number
	Plug = 025-31315-000  Pin = 025-20919-000	P36	1	2	24	Cooler Heater	575-54455-204
			2	29			
			3	Ground			

# TRANSDUCERS, TEMP SENSORS, HPCO AND OIL LINE CONNECTIONS

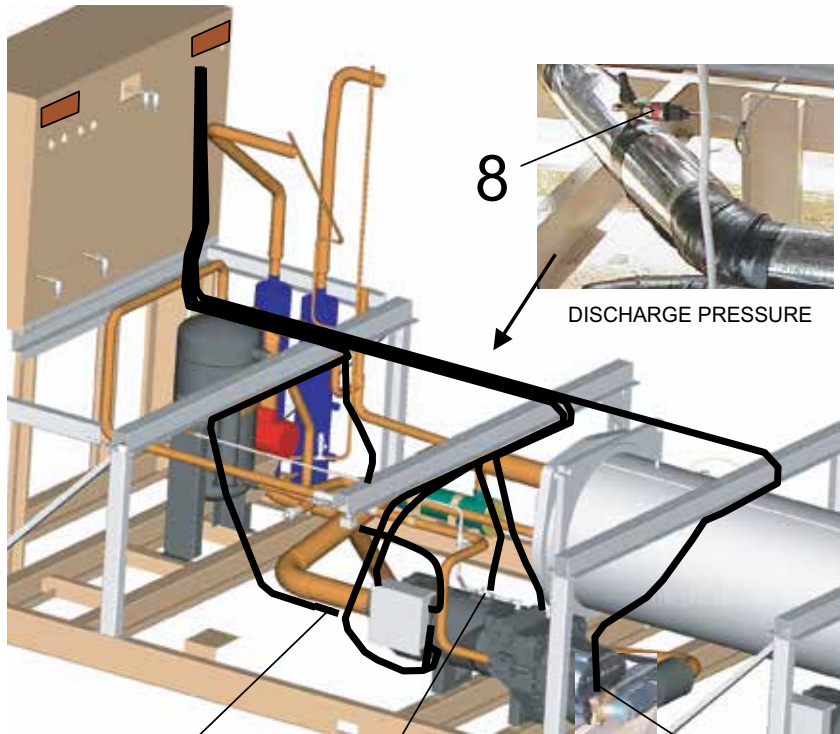

55832-000D-1a

55832-000A-1

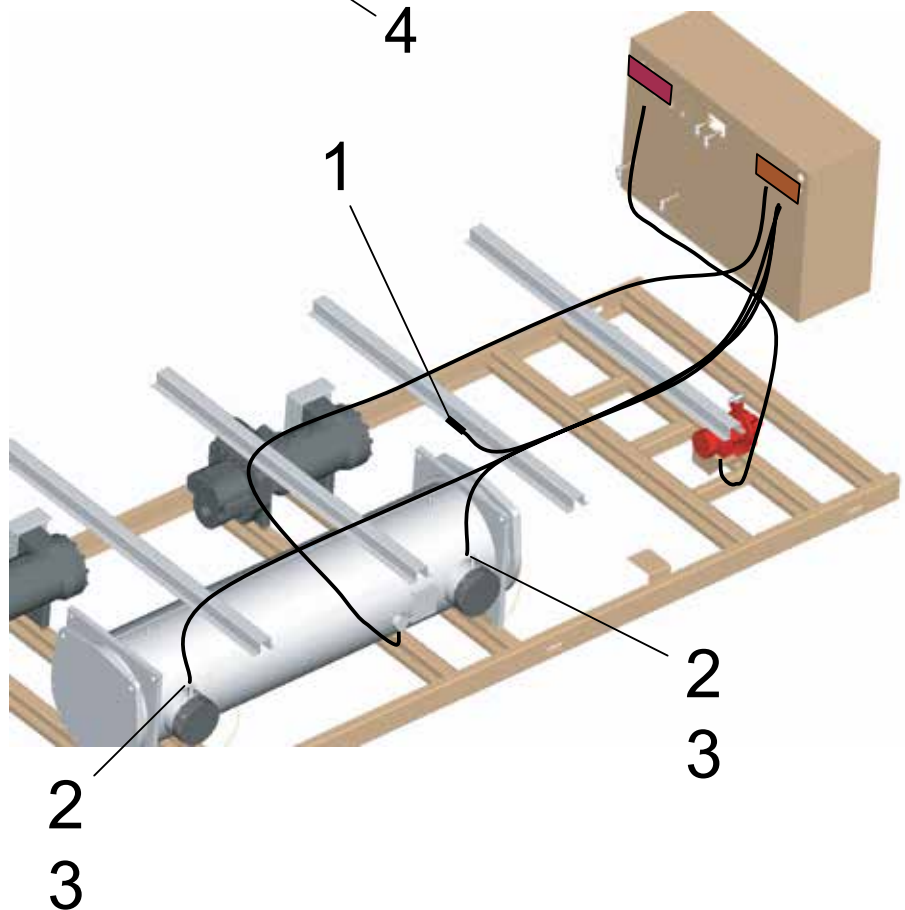

**FIG. 13 – TRANSDUCERS AND TEMP SENSORS (REF. TABLE 14, PAGE 56)**

## TRANSDUCERS, TEMP SENSORS, HPCO AND OIL LINE CONNECTIONS (CONT'D)

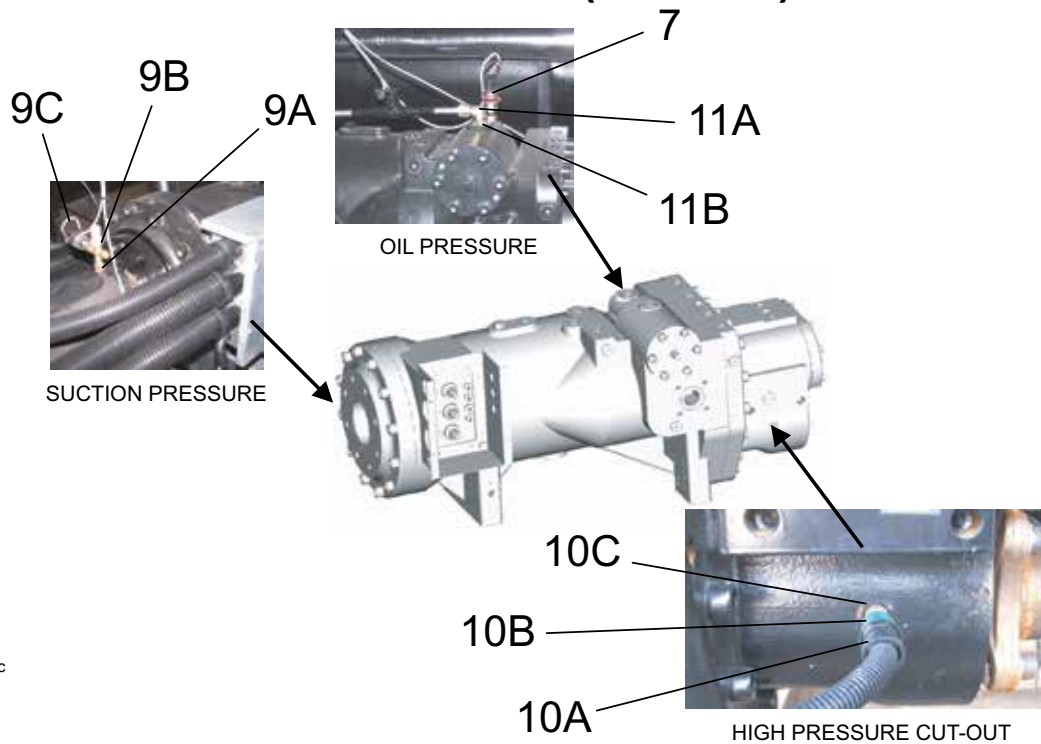

55658-000c

**FIG. 13A – TRANSDUCERS AND HIGH PRESSURE CUT-OUT**

**TABLE 14 – TRANSDUCERS, TEMP SENSORS AND HIGH PRESSURE CUT-OUT SWITCH (SEE FIGS. 13 AND 13A, PAGES 55 AND 56)**

Item #	Quantity	Description	Voltage Code	Part Number
1 <sup>S</sup>	1	Sensor, Outside Air Temperature	All	025-28663-001
2 <sup>S</sup>	2	Sensor, Water Temp. (EWT, LWT)	All	025-40334-000
3	-	Compound, Heat Conductive	All	013-00898-000
4 <sup>S</sup>	2 per system	Sensor, Discharge Temperature	All	025-32924-000
5 <sup>S</sup>	2 per system	Sensor, Suction Temperature	All	025-28935-000
6 <sup>S</sup>	2 per system	Sensor, Oil Temperature	All	025-30440-000
7 <sup>S</sup>	1 per system	Transducer, Oil Pressure (0-275psi)	All	025-29139-003
8 <sup>S</sup>	1 per system	Transducer, Discharge Pressure (0-275psi)	All	025-29139-003
9A	1 per system	Adapter, 3/4"-16M x 1/4 NPTF	All	023-18225-000
9B		Valve, Transducer w/ 1/4" Flange	All	022-09503-000
9C <sup>S</sup>		Transducer, Suction Pressure (0-125psi)	All	025-29583-001
10A	1 per system	Connector, 7/16"-20M	All	023-18087-000
10B		High Pressure Cut Out Switch	All	025-39956-000
10C		O-ring (Use with ITEM 10A)	All	028-13540-000
11A	1 per system	Elbow, 90° Oil Inlet	All	023-18945-000
11B		O-ring (Use with ITEM 11A)	All	028-12961-004

<sup>S</sup> Recommended Spare Part

## TRANSDUCER AND THERMISTOR WIRE HARNESS CONNECTORS - FIELD REPLACEMENT PART NUMBERS

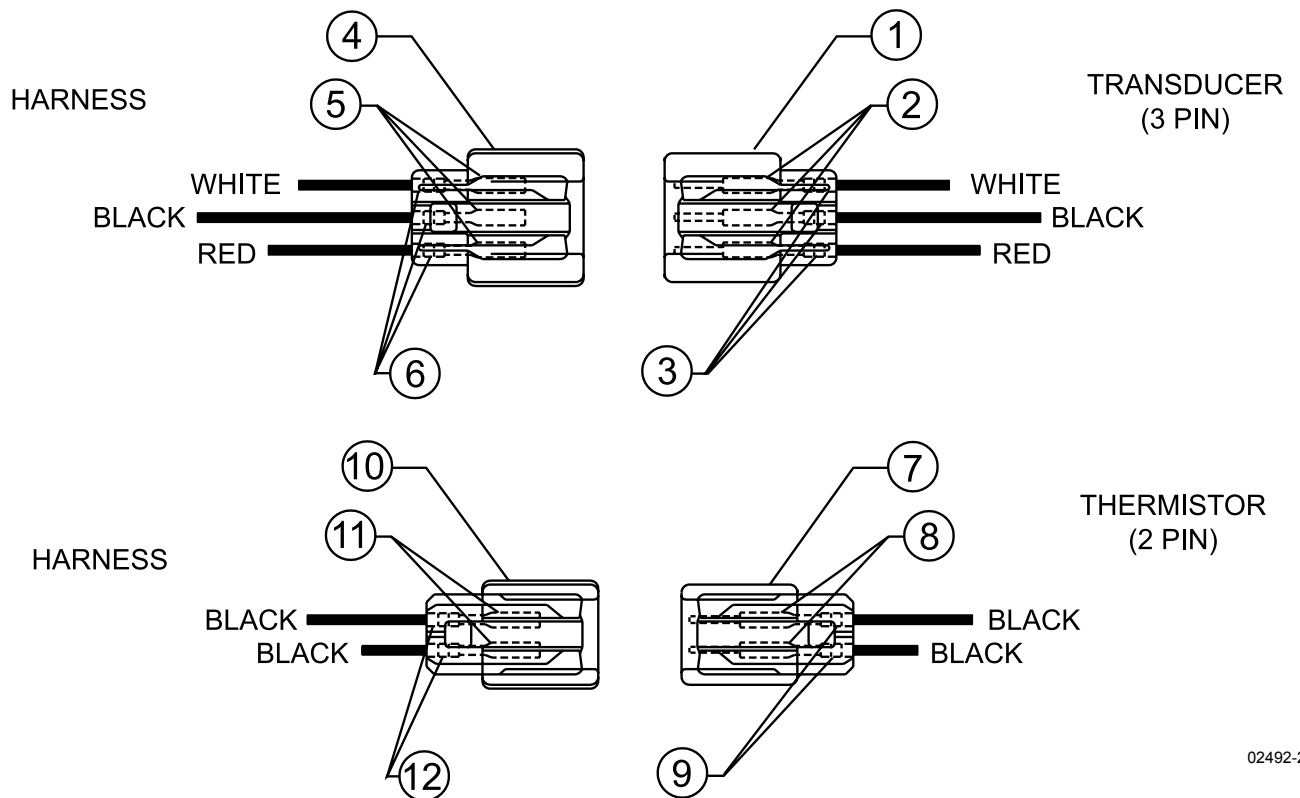

02492-2b

**FIG. 14 – TRANSDUCER AND THERMISTOR WIRE HARNESS CONNECTORS - FIELD REPLACEMENT PART NUMBERS (REF. TABLE 15)**

**TABLE 15 – TRANSDUCER AND THERMISTOR WIRE HARNESS CONNECTORS - FIELD REPLACEMENT PART NUMBERS (SEE FIG. 14)**

Item No.	Location	Description	Pins	Part Number
1	Transducer	Plug Connector	3 Pin End	025-28953-000
2		Contact Pins		025-28949-000
3		Rubber Collar		025-28950-000
4	Wire Harness	Plug Connector	3 Pin End	025-28954-000
5		Contact Pins		025-28952-000
6		Rubber Collar		025-28950-000
7	Temperature Sensor	Plug Connector	2 Pin End	025-28948-000
8		Contact Pins		025-28949-000
9		Rubber Collar		025-28950-000
10	Wire Harness	Plug Connector	2 Pin End	025-28951-000
11		Contact Pins		025-28952-000
12		Rubber Collar		025-28950-000

<sup>s</sup> Recommended Spare Part

# VIBRATION ISOLATORS

**TABLE 16 – INDIVIDUAL VIBRATION ISOLATOR PART NUMBERS**

<b>ONE INCH DEFLECTION SPRING ISOLATOR CROSS REFERENCE</b>				
FOR UNITS WITH <b>ALL</b> POINT LOADS LESS THAN 1404 LBS. (637 KG.)				
<b>WEIGHT RANGE (lbs.)</b>	<b>WEIGHT RANGE (kg.)</b>	<b>VENDOR PART NUMBER</b>	<b>COLOR</b>	<b>YORK PART NUMBER</b>
239 to 384 lbs.	108 to 174 kg.	CIP-B-450	RED	029-24583-002
384 to 639 lbs.	174 to 290 kg.	CIP-B-750	WHITE	029-24583-003
639 to 851 lbs.	290 to 386 kg.	CIP-B-1000	BLUE	029-24583-004
851 to 1064 lbs.	386 to 483 kg.	CIP-B-1250	GRAY	029-24583-005
1064 to 1404 lbs.	483 to 637 kg.	CIP-B-1650	BLACK	029-24583-006
FOR UNITS WITH <b>ANY</b> POINT LOAD ABOVE 1404 LBS. (637 KG.)				
<b>WEIGHT RANGE (lbs.)</b>	<b>WEIGHT RANGE (kg.)</b>	<b>VENDOR PART NUMBER</b>	<b>COLOR</b>	<b>YORK PART NUMBER</b>
Up to 851 lbs.	Up to 386 kg.	CIP-B-1000	BLACK	029-24583-007
851 to 1149 lbs.	386 to 521 kg.	CIP-B-1350	YELLOW	029-24583-008
1149 to 1489 lbs.	521 to 675 kg.	CIP-B-1750	BLACK	029-24583-009
1489 to 1786 lbs.	675 to 910 kg.	CIP-B-2100	YELLOW W/ RED	029-24583-010
1786 to 2028 lbs.	910 to 920 kg.	CIP-B-2385	YELLOW W/ GREEN	029-24583-011
2028 to 2254 lbs.	920 to 1022 kg.	CIP-B-2650	RED W/ RED	029-24583-012
2254 to 2936 lbs.	1022 to 1332 kg.	CIP-B-2935	RED W/ GREEN	029-24583-013

<b>NEOPRENE ISOLATOR CROSS REFERENCE</b>				
<b>WEIGHT RANGE (lbs.)</b>	<b>WEIGHT RANGE (kg.)</b>	<b>VENDOR PART NUMBER</b>	<b>COLOR</b>	<b>YORK PART NUMBER</b>
Up to 751 lbs.	Up to 341 kg.	ND-C	YELLOW	029-24584-001
751 to 1651 lbs.	341 to 749 kg.	ND-D	YELLOW	029-24584-002
1651 to 3226 lbs.	749 to 1463 kg.	ND-DS	YELLOW	029-24584-004

<b>TWO INCH DEFLECTION, SEISMIC SPRING ISOLATOR CROSS REFERENCE</b>				
<b>WEIGHT RANGE (lbs.)</b>	<b>WEIGHT RANGE (kg.)</b>	<b>VENDOR PART NUMBER</b>	<b>COLOR</b>	<b>YORK PART NUMBER</b>
Up to 358 lbs.	Up to 162 kg.	SLRS-2-C2-420	RED	029-24585-006
358 to 443 lbs.	162 to 201 kg.	SLRS-2-C2-520	WHITE	029-24585-007
443 to 582 lbs.	201 to 264 kg.	SLRS-2-C2-660	BLACK	029-24585-008
582 to 783 lbs.	264 to 335 kg.	SLRS-2-C2-920	BLUE	029-24585-009
783 to 1038 lbs.	335 to 471 kg.	SLRS-2-C2-1220	GREEN	029-24585-010
1038 to 1497 lbs.	471 to 679 kg.	SLRS-2-C2-1760	GRAY	029-24585-011
1497 to 2058 lbs.	679 to 933 kg.	SLRS-2-C2-2420	SILVER	029-24585-012
2058 to 2619 lbs.	933 to 1188 kg.	SLRS-2-C2-3080	GRAY W/ RED	029-24585-013
2619 to 3180 lbs.	1188 to 1442 kg.	SLRS-2-C2-3740	SILVER W/ RED	029-24585-014

## YCAV CHILLER OPTIONS

**TABLE 17 – FIELD INSTALLED OPTIONS PART NUMBERS**

MODEL NUMBER YCAV	STANDARD 150# FLOW SWITCH	OPTIONAL 300# FLOW SWITCH	CHICAGO RELIEF VALVE	WELD FLANGE KIT	VICTAULIC FLANGE KIT	DIFFERENTIAL PRESSURE SWITCH
<b>MODEL #</b>	024-26116	024-12144	375-56090	023-02366	023-	025-30919
<b>0157</b>	-000	-000	-001	-000	19046-000	-000
<b>0177</b>						
<b>0187</b>						
<b>0197</b>						
<b>0207</b>			N/A			
<b>0227</b>			-002			
<b>0247</b>			-003			
<b>0267</b>						

# ENCLOSURE KIT OPTIONS

**TABLE 18 – FIELD INSTALLED ENCLOSURE KIT OPTIONS**

FULL ENCLOSURE KIT PART NUMBERS				
MODEL NUMBER YCAV-	WIRE ENCLOSURE VOLTAGE CODE = 46		WIRE ENCLOSURE VOLTAGE CODES = 17, 28 40, 50 & 58	
	STANDARD EFFICIENCY	HIGH EFFICIENCY	STANDARD EFFICIENCY	HIGH EFFICIENCY
0157	475-57105-008	475-57105-008	475-57106-008	475-57106-008
0177	475-57105-008	475-57105-009	475-57106-008	475-57106-009
0187	475-57105-009	475-57105-010	475-57106-009	475-57106-010
0197	N/A	475-57105-010	N/A	475-57106-010
0207	475-57105-009	475-57105-011	475-57106-009	475-57106-011
0227	475-57105-010	475-57105-012	475-57106-010	475-57106-012
0247	475-57105-011	475-57105-012	475-57106-011	475-57106-012
0267	475-57105-012	N/A	475-57106-012	N/A

FULL ENCLOSURE KIT PART NUMBERS				
MODEL NUMBER YCAV-	LOUVERED ENCLOSURE VOLTAGE CODES = 46		LOUVERED ENCLOSURE VOLTAGE CODES = 17, 28 40, 50 & 58	
	STANDARD EFFICIENCY	HIGH EFFICIENCY	STANDARD EFFICIENCY	HIGH EFFICIENCY
0157	475-57097-008	475-57097-008	475-57098-008	475-57098-008
0177	475-57097-008	475-57097-010	475-57098-008	475-57098-010
0187	475-57097-010	475-57097-010	475-57098-010	475-57098-010
0197	N/A	475-57097-010	N/A	475-57098-010
0207	475-57097-010	475-57097-012	475-57098-010	475-57098-012
0227	475-57097-010	475-57097-012	475-57098-010	475-57098-012
0247	475-57097-012	475-57097-012	475-57098-012	475-57098-012
0267	475-57097-012	N/A	475-57098-012	N/A

FULL ENCLOSURE KIT PART NUMBERS				
MODEL NUMBER YCAV-	WIRE/LOUVERED ENCLOSURE VOLTAGE CODES = 46		WIRE/LOUVERED ENCLOSURE VOLTAGE CODES = 17, 28 40, 50 & 58	
	STANDARD EFFICIENCY	HIGH EFFICIENCY	STANDARD EFFICIENCY	HIGH EFFICIENCY
0157	475-57107-008	475-57107-008	475-57108-008	475-57108-008
0177	475-57107-008	475-57107-010	475-57108-008	475-57108-010
0187	475-57107-010	475-57107-010	475-57108-010	475-57108-010
0197	N/A	475-57107-010	N/A	475-57108-010
0207	475-57107-010	475-57107-012	475-57108-010	475-57108-012
0227	475-57107-010	475-57107-012	475-57108-010	475-57108-012
0247	475-57107-012	475-57107-012	475-57108-012	475-57108-012
0267	475-57107-012	N/A	475-57108-012	N/A

## ENCLOSURE KIT OPTIONS (CONT'D)

**TABLE 18A – ENCLOSURE KIT OPTIONS - TOP AND BOTTOM SECTIONS**  
(SEE FIGS. 15-18, PAGES 62-67)

FULL KIT NUMBER	TOP OR BOTTOM	PART NUMBER
<b>WIRE ENCLOSURES VOLTAGE CODE = 46</b>		
475-57105-008	(Top)	375-57105-080
	(Bottom)	375-57105-081
475-57105-009	(Top)	375-57105-090
	(Bottom)	375-57105-101
475-57105-010	(Top)	375-57105-100
	(Bottom)	375-57105-101
475-57105-011	(Top)	375-57105-110
	(Bottom)	375-57105-121
475-57105-012	(Top)	375-57105-120
	(Bottom)	375-57105-121
<b>LOUVERED ENCLOSURE VOLTAGE CODE = 46</b>		
475-57097-008	(Top)	375-57097-080
	(Bottom)	375-57097-081
475-57097-010	(Top)	375-57097-100
	(Bottom)	375-57097-101
475-57097-012	(Top)	375-57097-120
	(Bottom)	375-57097-121
<b>WIRE/LOUVERED ENCLOSURE VOLTAGE CODE = 46</b>		
475-57107-008	(Top)	375-57097-080
	(Bottom)	375-57105-081
475-57107-010	(Top)	375-57097-100
	(Bottom)	375-57105-101
475-57107-012	(Top)	375-57097-120
	(Bottom)	375-57105-121
<b>LOUVERED ENCLOSURE (COND. ONLY) VOLTAGE CODE = 46</b>		
475-57097-080	(Top)	475-57097-080
	(Bottom)	N/A
475-57097-010	(Top)	475-57097-010
	(Bottom)	N/A
475-57097-012	(Top)	475-57097-012
	(Bottom)	N/A

FULL KIT NUMBER	TOP OR BOTTOM	PART NUMBER
<b>WIRE ENCLOSURES VOLTAGE CODES = 17, 28 40, 50 &amp; 58</b>		
475-57106-008	(Top)	375-57105-080
	(Bottom)	375-57106-081
475-57106-009	(Top)	375-57105-090
	(Bottom)	375-57106-101
475-57106-010	(Top)	375-57105-100
	(Bottom)	375-57106-101
475-57106-011	(Top)	375-57105-110
	(Bottom)	375-57106-121
475-57106-012	(Top)	375-57105-120
	(Bottom)	375-57106-121
<b>LOUVERED ENCLOSURE VOLTAGE CODES = 17, 28 40, 50 &amp; 58</b>		
475-57098-008	(Top)	375-57097-080
	(Bottom)	375-57098-081
475-57098-010	(Top)	375-57097-100
	(Bottom)	375-57098-101
475-57098-012	(Top)	375-57097-120
	(Bottom)	375-57098-121
<b>WIRE/LOUVERED ENCLOSURE VOLTAGE CODES = 17, 28 40, 50 &amp; 58</b>		
475-57108-008	(Top)	375-57097-080
	(Bottom)	375-57106-081
475-57108-010	(Top)	375-57097-100
	(Bottom)	375-57106-101
475-57108-012	(Top)	375-57097-120
	(Bottom)	375-57106-121
<b>LOUVERED ENCLOSURE (COND. ONLY) VOLTAGE CODES = 17, 28 40, 50 &amp; 58</b>		
475-57097-080	(Top)	475-57097-080
	(Bottom)	N/A
475-57097-010	(Top)	475-57097-010
	(Bottom)	N/A
475-57097-012	(Top)	475-57097-012
	(Bottom)	N/A

## ENCLOSURE KIT OPTIONS (CONT'D)

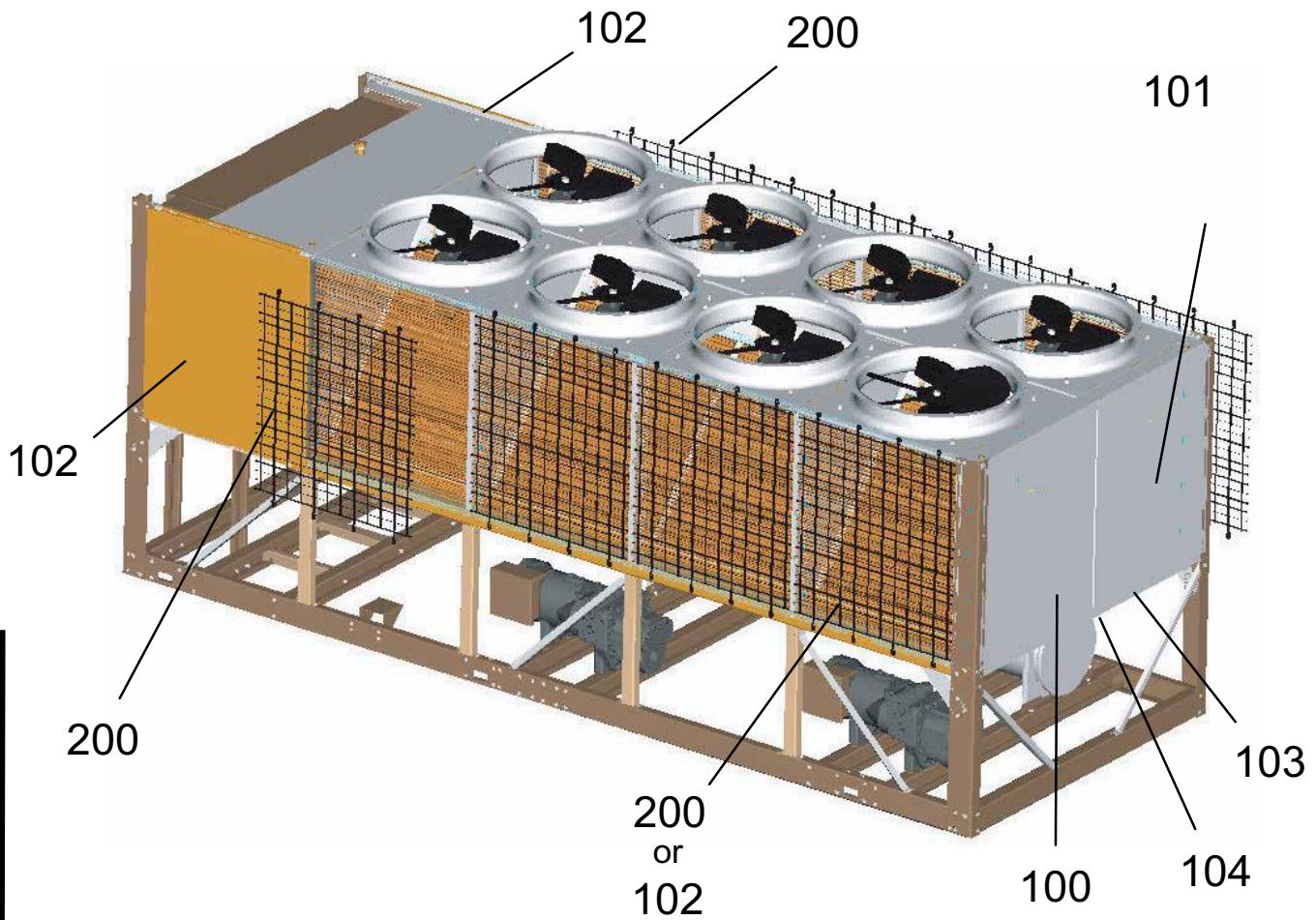

\* Use item 102 on units with an odd number of fans.

57105-000

**FIG. 15 – WIRE ENCLOSURE (TOP SECTIONS) - 375-57105-080 SHOWN (REF. TABLE 19)**

**TABLE 19 – WIRE ENCLOSURE (TOP SECTIONS) - (SEE FIG. 15)**

WIRE ENCLOSURE TOP SECTIONS KIT COMPONENTS			
ITEM #	DESCRIPTION	PART NUMBER	QTY
100	END PANEL - LH	075-57085-000	1
101	END PANEL - RH	075-57086-000	1
102*	PANEL	075-56977-000	2
103	CHANNEL	075-57082-000	1
104	PLATE	075-57138-000	1
200	WIRE GRILL CONDENSER	026-41776-000	8**

\*\* Refer to page 55, Quantity for 375-57105-090 = 9

\*\* Refer to page 55, Quantity for 375-57105-100 = 10

\*\* Refer to page 55, Quantity for 375-57105-110 = 11

\*\* Refer to page 55, Quantity for 375-57105-120 = 12

## ENCLOSURE KIT OPTIONS (CONT'D)

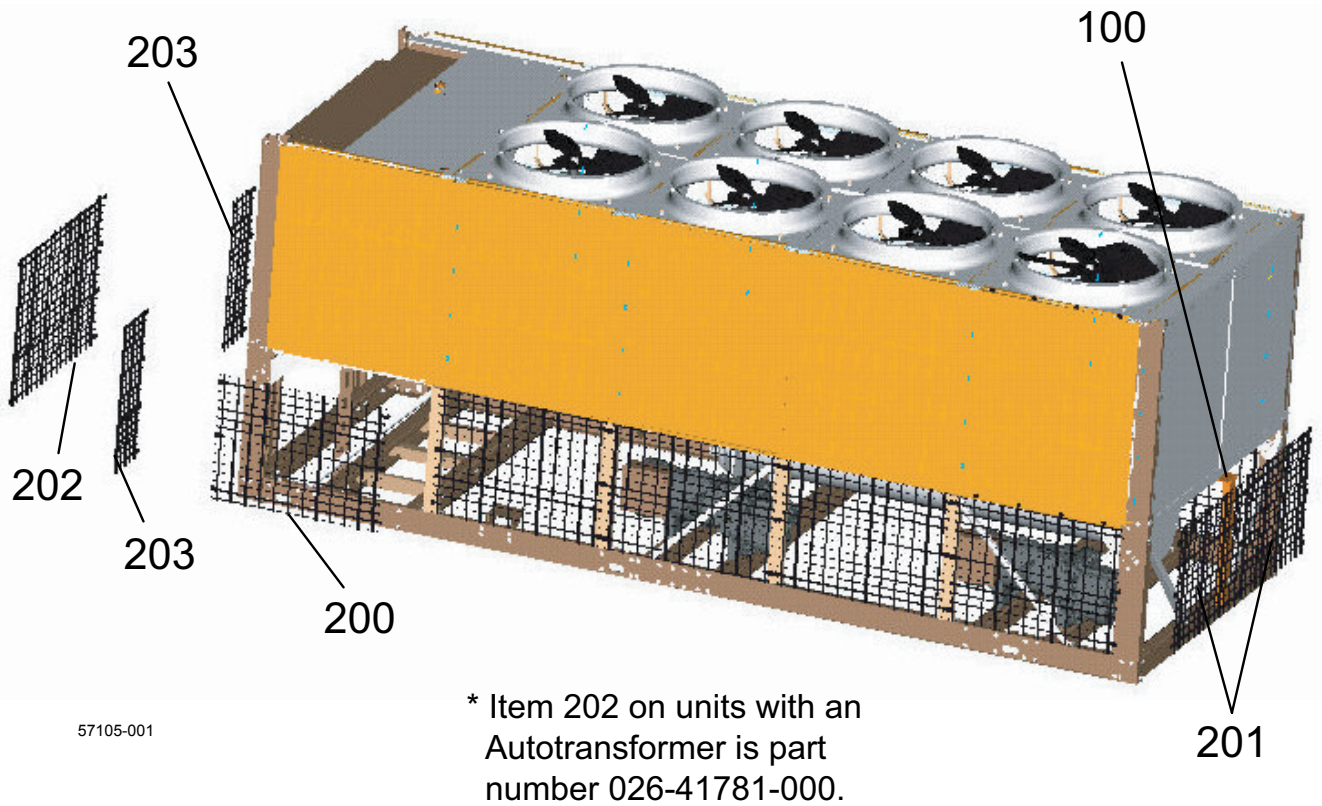

Enclosure Options

**FIG. 16 – WIRE ENCLOSURE (BOTTOM SECTIONS) - 375-57106-081 SHOWN (REF. TABLE 20)**

**TABLE 20 – WIRE ENCLOSURE (BOTTOM SECTIONS) - (SEE FIG. 16)**

WIRE ENCLOSURE BOTTOM SECTIONS KIT COMPONENTS			
ITEM #	DESCRIPTION	PART NUMBER	QTY
100	REAR SUPPORT	075-56979-000	1
200	WIRE GRILL	026-41777-000	10**
201	WIRE GRILL - REAR	026-41778-000	2
202	WIRE GRILL	026-41779-000	1
203	WIRE GRILL	026-41780-000	2

\*\* Refer to page 55, Quantity for 375-57106-101 = 12

\*\* Refer to page 55, Quantity for 375-57106-201 = 14

## ENCLOSURE KIT OPTIONS (CONT'D)

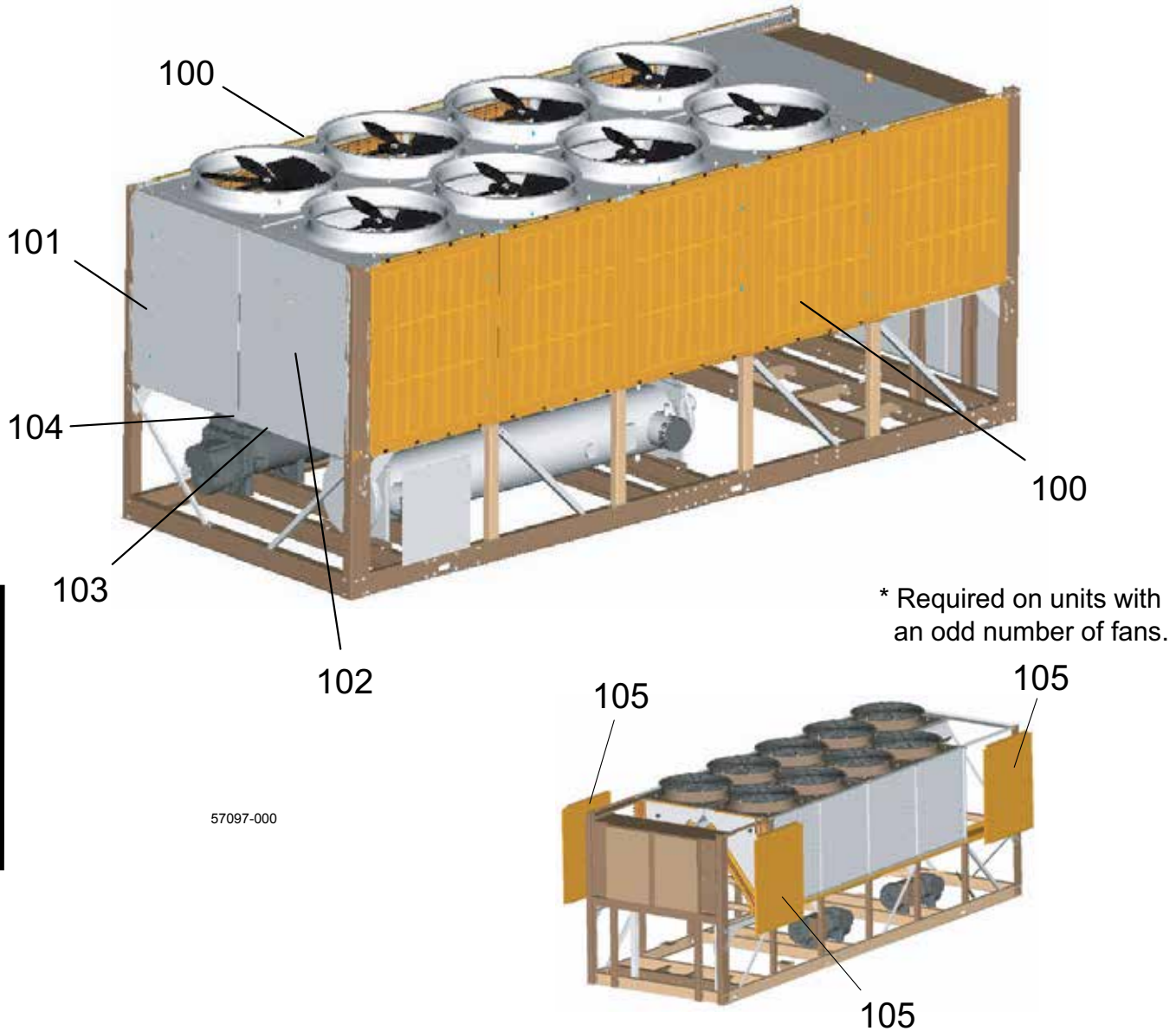

**FIG. 17 – LOUVERED ENCLOSURE (TOP SECTIONS) - 375-57097-080 SHOWN (REF. TABLE 21)**

**TABLE 21 – LOUVERED ENCLOSURE (TOP SECTIONS) - (SEE FIG. 17)**

LOUVERED ENCLOSURE TOP SECTIONS KIT COMPONENTS			
ITEM #	DESCRIPTION	PART NUMBER	QTY
100	LOUVER PANEL	075-56976-000	10**
101	REAR PANEL - LH	075-57085-000	1
102	REAR PANEL - RH	075-57086-000	1
103	CHANNEL	075-57082-000	1
104	REAR SUPPORT	075-57133-000	1
105	PANEL	075-56977-000	3*

\*\* Refer to page 55, Quantity for 375-57097-100 = 12

\*\* Refer to page 55, Quantity for 375-57097-200 = 14

# ENCLOSURE KIT OPTIONS (CONT'D)

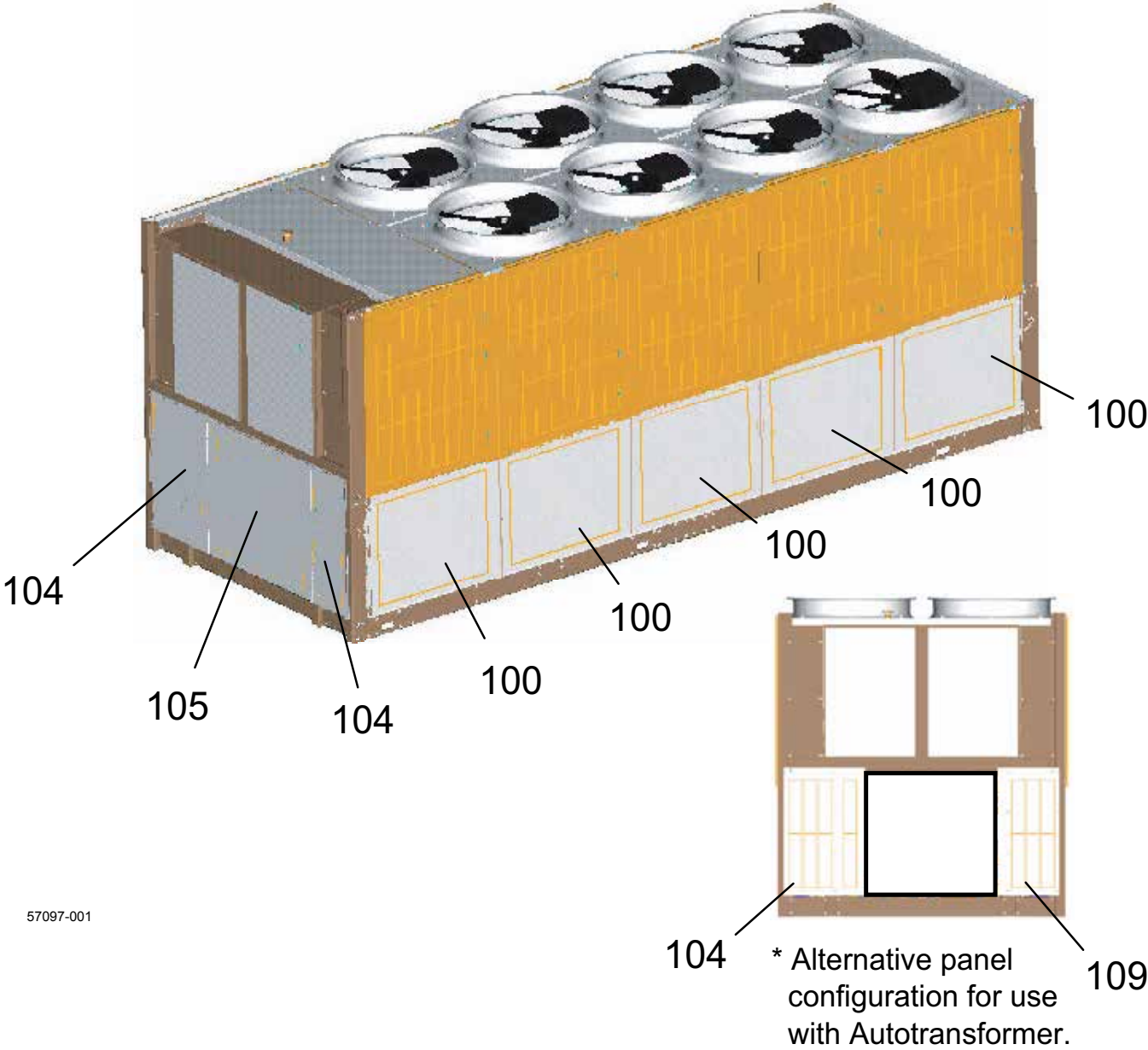

Enclosure Options

57097-001

**FIG. 18 – LOUVERED ENCLOSURE (BOTTOM SECTIONS)**  
375-57097-081 SHOWN (REF. TABLE 22, PAGE 66)

## ENCLOSURE KIT OPTIONS (CONT'D)

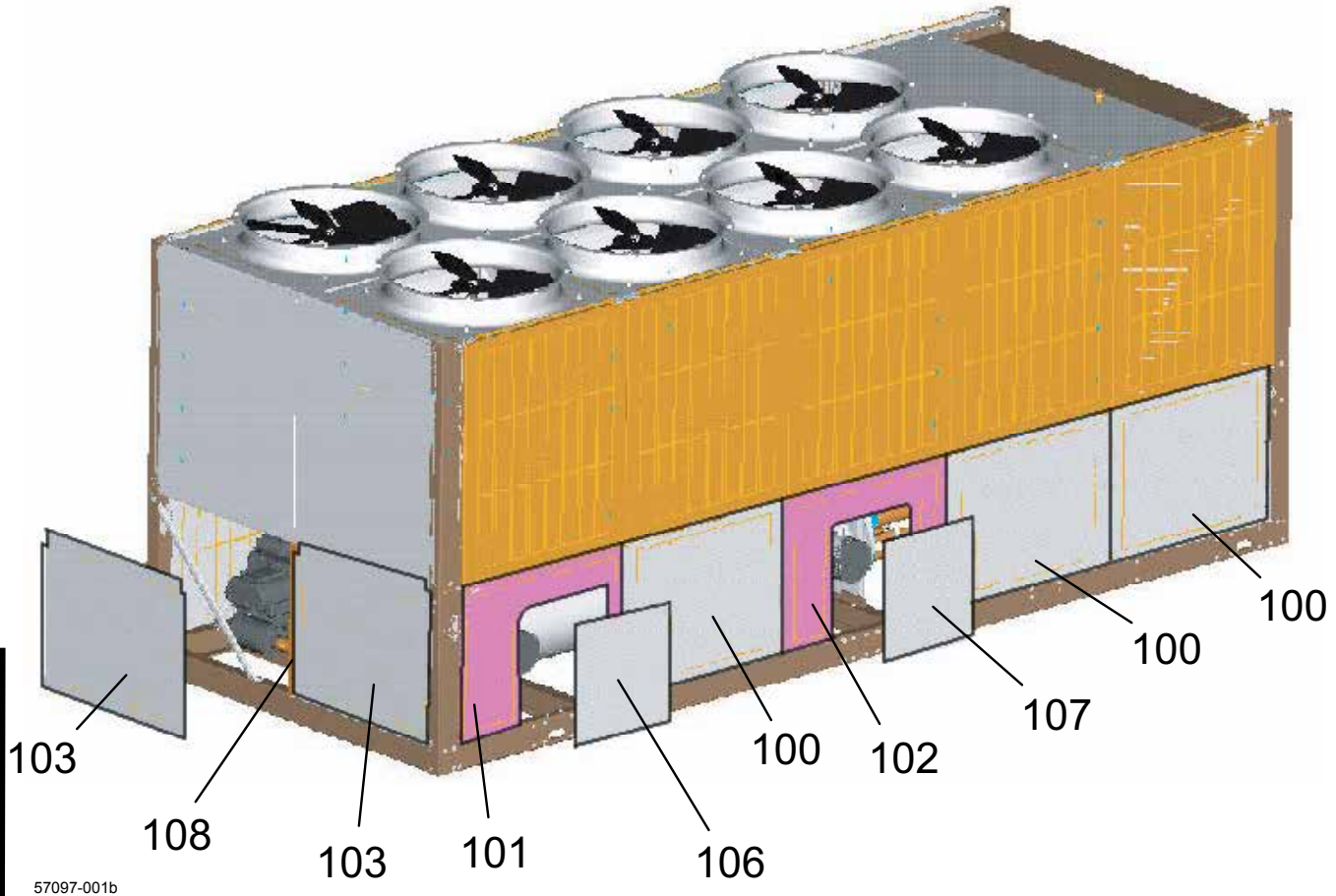

**FIG. 18A – LOUVERED ENCLOSURE (BOTTOM SECTIONS)**  
375-57098-081 SHOWN (REF. TABLE 22)

**TABLE 22 – LOUVERED ENCLOSURE (BOTTOM SECTIONS)**  
(SEE FIGS. 18 AND 18A)

LOUVERED ENCLOSURE BOTTOM SECTIONS KIT COMPONENTS			
ITEM #	DESCRIPTION	PART NUMBER	QTY
100	LOUVER PANEL	075-56978-000	8**
101	LOUVER PANEL	075-57111-000	1
102	LOUVER PANEL	075-57113-000	1
103	LOUVER PANEL	075-56981-000	2
104	LOUVER PANEL	075-57101-000	2*
105	LOUVER PANEL	075-57102-000	1*
106	COVER PANEL	075-57112-000	1
107	COVER PANEL	075-57115-000	1
108	REAR SUPPORT	075-56979-000	1
109	LOUVER PANEL - FRONT	075-57104-000	1*

\*\* Refer to page 55, Quantity for 375-57098-101 = 12

\*\* Refer to page 55, Quantity for 375-57098-201 = 14

# RECOMMENDED SPARE PARTS

York Model YCAV Style A Air Cooled Screw Chillers  
Suggested Spare Parts List for Critical Duty Applications

**TABLE 24 – RECOMMENDED SPARE PARTS - YCAV0157-YCAV0267 CHILLERS**

PAGE REF. & ITEM NUMBER	DESCRIPTION	MODEL NUMBER YCAV	PART NUMBER
Pages 14, Item 1	Fan Motor (Standard)	-17	024-27322-007
		-28	
		-40	
		-46	
		-50	024-27322-008
		-58	024-27322-007
Pages 14, Item 1	Fan Motor (Low Noise)	-17	024-34980-001
		-28	
		-40	
		-46	
		-50	
		-58	
Pages 14, Item 2	Fan Blade (Standard)	All	026-41594-000
	Fan Blade (Low Noise)	All	026-41942-000
Pages 20, 21 and 22, Item 1	Valve, Control (Feed or Drain)	See Table 4	025-41564-000
			025-41565-000
Page 20, 21 and 22, Item 5	Core, Dehydrator	All	026-37540-000
Page 20, 21 and 22, Item 18	Sensor, Refrig Level	All	025-40274-000
Page 25, Item 10	Cap, Radiator	All	023-21927-000
Page 25, Item 13	Coolant Propylene Glycol (5 gallon)	All	013-03344-000
Page 26, Item OIL	Oil, Compressor (Type 'L')	R-134A	011-00592-000
Page 36, Item 28	Chiller Control Board	All	031-02478-002
Page 36, Item 72	Controller, Drain/Feed (90° Flow)	See Table 7	031-02510-000
	Controller, Drain/Feed (Straight Flow)		031-02742-000
Page 37-41, Item 190	VSD Logic Board	All	031-02477-000*
Page 37-41, Item 190a	VSD Logic Board	All	031-02507-000
Page 56, Item 1	Sensor, Outside Air Temperature	All	025-28663-001
Page 56, Item 2	Sensor, Water Temp. (EWT, LWT)	All	025-40334-000
Page 56, Item 4	Sensor, Discharge Temperature	All	025-32924-000
Page 56, Item 5	Sensor, Suction Temperature	All	025-28935-000
Page 56, Item 6	Sensor, Oil Temperature	All	025-30440-000
Page 56, Item 7 and 8	Transducer, Discharge & Oil Pressure (0-275psi)	All	025-29139-003
Page 56, Item 9c	Transducer, Suction Pressure (0-125psi)	All	025-29583-001

\* OBSOLETE. Refer to pages 37-41.

All parts should be purchased from your local YORK  
Sales and Service Center.



P.O. Box 1592, York, Pennsylvania USA 17405-1592  
Copyright © by Johnson Controls 2016  
Form 201.21-RP1 (616)  
Issue Date: June 30, 2016  
Supersedes: 201.21-RP1 (114)

800-861-1001  
[www.johnsoncontrols.com](http://www.johnsoncontrols.com)

Subject to change without notice. Printed in USA  
ALL RIGHTS RESERVED