



Service Information

File In/With: YCAS & YCWS Manuals

SI0331

New 916

Equipment Affected: YCAS / YCWS DXS12, DXS24, DXS36, and DXS45 Compressors

Replacing the Slide Valve Return Spring
(On Compressors That Do Not Fully Unload)

SYMPTOM

Compressor starts partially loaded and %FLA change from fully unloaded to fully loaded is less than 20% on a YCAS chiller and less than 15% on a YCWS chiller. If changing the capacity control valve had no effect and the measured pressures (as outlined in the Compressor Loading/Unloading diagnosis procedure) are less than 1.2 x suction pressure, then see Figure 2.

GENERAL

The compressor loading may appear to fluctuate marginally with current running high when the compressor should be running fully unloaded. This is a result of a broken slide valve return spring. The severity of the problem will be a result of the number of breaks in the spring, and the amount the spring is shortened due to the segments winding together.

TOOLS

12" wrench extensions, 10mm Hex Socket, 14mm Hex Socket and adjustable torque wrench.

PARTS LIST

Order the appropriate kit for the compressor from Baltimore Parts Center using the table below.

COMPRESSOR	PART NUMBER
DXS12	364-51136-004
DXS24	364-51136-003
DXS36	364-51136-002
DXS45	364-51336-001

Work on this equipment should only be done by properly trained personnel who are qualified to work on this type of equipment. Failure to comply with this requirement could expose the worker, the equipment and the building and its inhabitants to the risk of injury or property damage.

The instructions on this service bulletin are written assuming the individual who will perform this work is a fully trained HVAC & R journeyman or equivalent, certified in refrigerant handling and recovery techniques, and knowledgeable with regard to electrical lock out/tag out procedures. The individual performing this work should be aware of and comply with all Johnson Controls, national, state and local safety and environmental regulations while carrying out this work. Before attempting to work on any equipment, the individual should be thoroughly familiar with the equipment by reading and understanding the associated service literature applicable to the equipment. If you do not have this literature, you may obtain it by contacting a Johnson Controls Service Office.

Should there be any question concerning any aspect of the tasks outlined in this bulletin, please consult a Johnson Controls Service Office prior to attempting the work. Please be aware that this information may be time sensitive and that Johnson Controls reserves the right to revise this information at any time. Be certain you are working with the latest information.

Kit contents are listed in Table 1 and shown in Figure 1.

TABLE 1 - KIT CONTENTS

ITEM	QTY	PART#	DESCRIPTIONS
1	1	026-13858-000	O-Ring 2-015
2	2	111R000050	SHCS ISO 4762M 16 x 240
3	2	111R000051	SHCS ISO 4762M 10 x 100 Fully threaded
4	1	Variable	O-Ring
5	1	Variable	Spring, Capacity Control
6	1	Variable	Piston, Capacity Control
7	1	Variable	Suction Flange Gasket

SPRING TEST

DO THE FOLLOWING TEST:

1. LEAVE CHILLER SIT FOR 3-4 HOURS
2. PRESSURE SHOULD EQUALIZE
3. START CHILLER
4. IF STARTS "UNLOADED" = **SPRING OK**
5. STARTS "**LOADED**" = SPRING / PISTON N/G

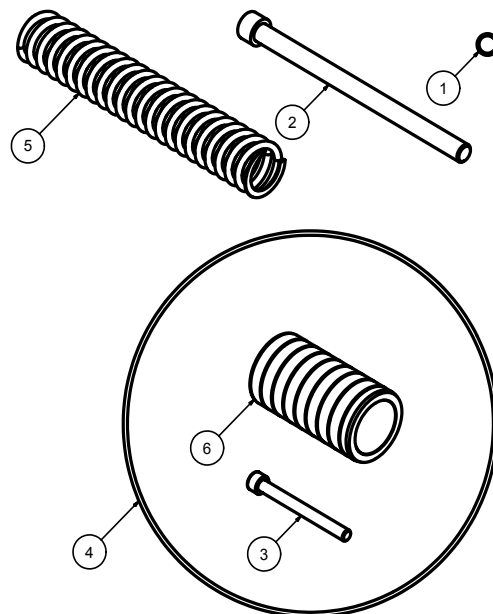

LDO9493

FIGURE 1 - SLIDE VALVE RETURN SPRING KIT

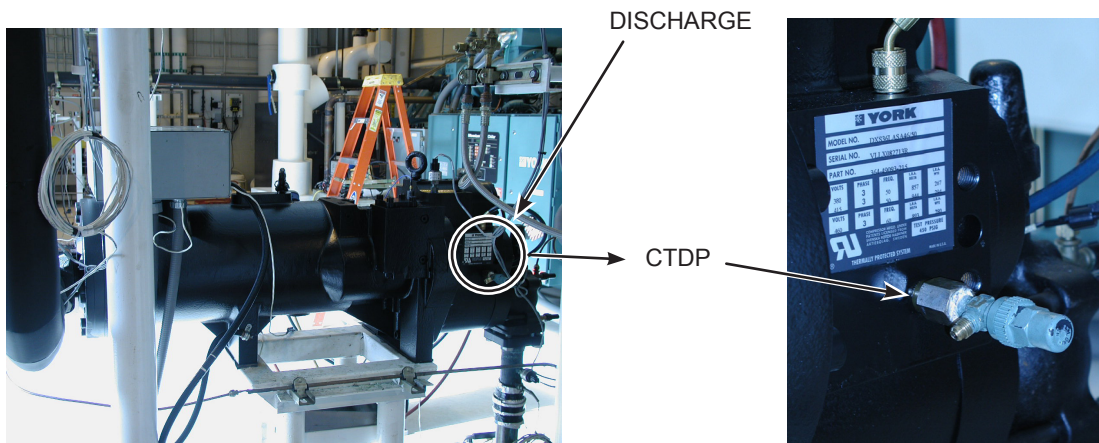

FIGURE 2 - SUCTION

COMPRESSOR DOES NOT LOAD/UNLOAD AFTER CHANGING CAPACITY CONTROL SOLENOID VALVE

Check "Closed Thread Drain Post" (CTDP) pressure located below the name plate/discharge side of the compressor while the compressor is running and compare to the suction pressure measured with a gauge. This port is sealed with a 7/16" O-ring plug and is located directly under the nameplate. Install a 7/16" x 20" UNF x 1/4" NPT coupling (023-18092-000).

$$\text{CALCULATED PRESSURE} = 1.2 \times \text{suction pressure (PSIG)}.$$

If the pressure measured at the CTDTP port is **GREATER THAN THE CALCULATED PRESSURE**, replace the compressor.

SELF - LOCKING NUT DXS SCREW COMPRESSOR

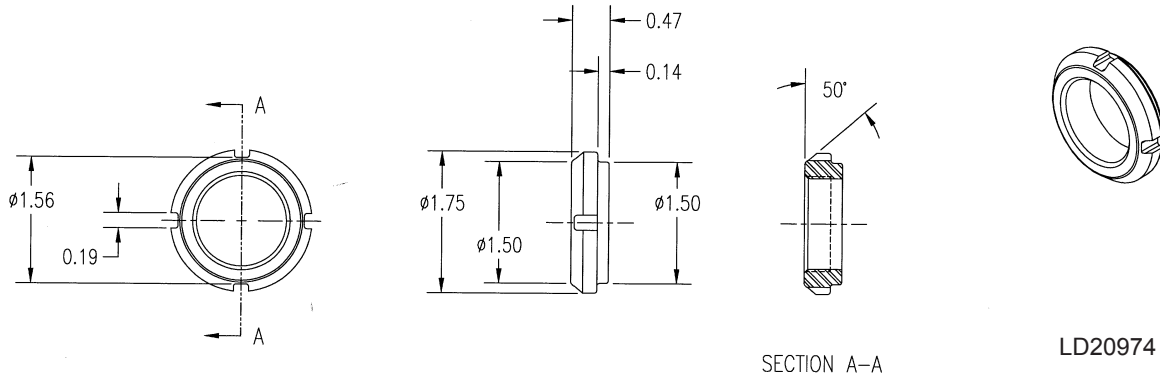

The above graphic (dwg) is of the 112 MM-90 ft lb

MINOR DIAMETER		PITCH DIAMETER		MAJOR DIAMETER	THREADS PER INCH	WHITTET HIGGINS DESIGNATION	COMP	TQ	DWG FILE #
MIN	MAX	MIN	MAX	MIN					
1.1129	1.1189	1.1369	1.1409	1.173	18	BH-06	112 MM	90 ft lbs	021-19362-000
1.3159	1.3219	1.3399	1.3439	1.376	18	BH-07	124 MM	120 ft lbs	021-19360-000
1.5029	1.5089	1.5269	1.5314	1.563	18	BH-08	136 MM	160 ft lbs	021-19100-000
1.7069	1.7129	1.7309	1.7354	1.767	18	BH-09	145 MM	200 ft lbs	021-19120-000