



*Millennium*TM
**AIR COOLED SCREW LIQUID CHILLERS
(STYLE F)**

WIRING DIAGRAM

Supersedes: 201.18-W1 (798)

Form 201.18-W1 (1298)

MODELS YCAS0130 THRU YCAS0230



28971A(r)

WARNING

HIGH VOLTAGE
is used in the operation of this equipment
DEATH OR SERIOUS INJURY
may result if personnel fail to observe precautions.

Work on electronic equipment should not be undertaken unless the individual(s) has (have) been trained in the proper maintenance of the equipment and is (are) familiar with its potential hazards.

Shut off power supply to equipment before beginning work and follow lockout procedures. When working inside equipment with power off, take special care to discharge every capacitor likely to hold dangerous potential.

Be careful not to contact high voltage connections when installing or operating this equipment.

LOW VOLTAGE
DO NOT be misled by the term "low voltage". Voltages as low as 50 volts
may cause death.

NOMENCLATURE

The Model Number denotes the following characteristics of the unit:

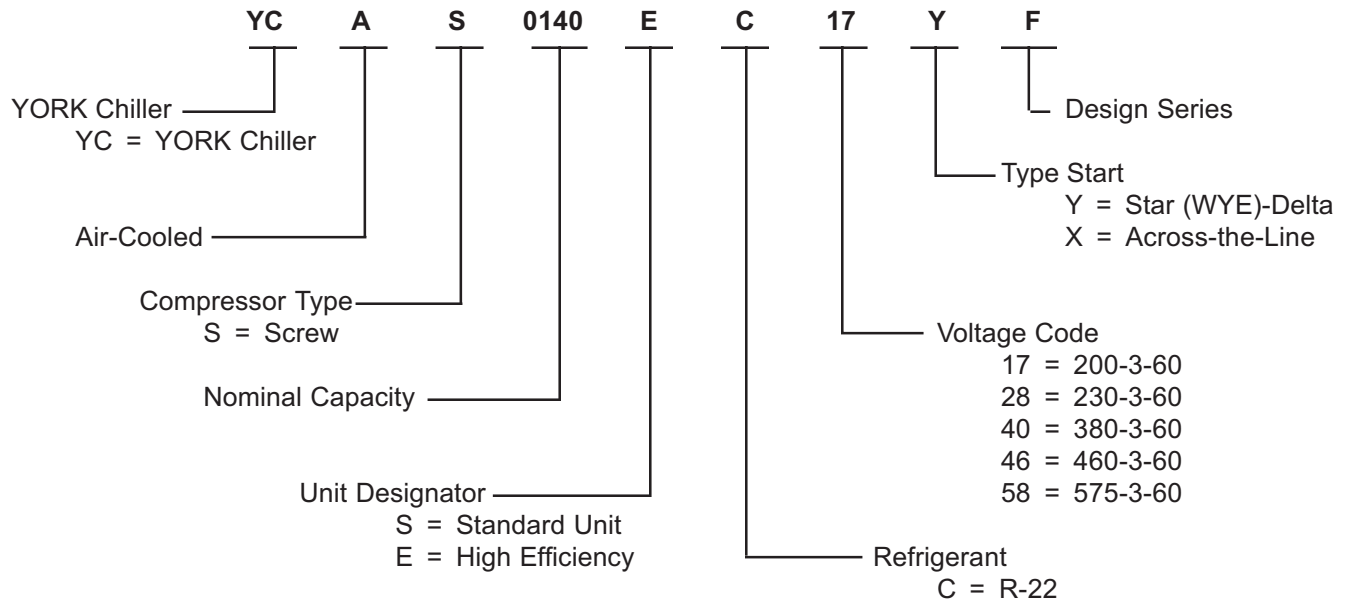

ELECTRICAL DATA

MULTIPLE POINT POWER SUPPLY CONNECTION

(Each of Two Field Provided Power Supply Circuits individually protected with Branch Circuit Protection.

Field Connections to Factory provided Terminal Block (Std), Disconnects (Opt), or Breakers(Opt) in each of the two Motor Control Centers.)

MODEL YCAS	VOLTS	SYSTEM #1 FIELD-SUPPLIED WIRING													
		MCA ¹	MIN NF DISC SW ²	D.E. FUSE		C.B.		FACTORY PROVIDED (LUGS) WIRE RANGE ⁷			COMPRESSOR			FANS	
				MIN. ³	MAX. ⁴	MIN. ⁵	MAX. ⁶	STD. TERMINAL BLOCK	OPT. NF SVC. DISC SW.	OPT. C.B.	RLA	Y-LRA	X-LRA	FLA (EA)	
0130EC	200	340	400	450	600	450	600	(2) # 2 - 300	(2) 3/0-250	(3) 2/0-400	246	444	1332	8.2	
	230	299	400	400	600	400	600	(2) # 2 - 300	(2) 3/0-250	(2) 3/0-250	214	386	1158	7.8	
	380	181	200	225	350	225	350	# 2 - 300	# 6 AWG - 350	# 6 AWG - 350	130	234	701	4.8	
	460	150	150	200	300	200	300	# 2 - 4/0	# 6 AWG - 350	# 6 AWG - 350	107	193	579	4.0	
	575	119	150	150	225	150	225	# 2 - 4/0	# 6 AWG - 350	# 6 AWG - 350	86	154	463	3.1	
0140EC	200	366	400	450	700	450	700	(2) # 2 - 300	(2) 3/0-250	(3) 2/0-400	267	444	1332	8.2	
	230	321	400	400	600	400	600	(2) # 2 - 300	(2) 3/0-250	(2) 3/0-250	232	386	1158	7.8	
	380	195	200	250	350	250	350	# 2 - 300	# 6 AWG - 350	# 6 AWG - 350	140	234	701	4.8	
	460	161	200	200	300	200	300	# 2 - 300	# 6 AWG - 350	# 6 AWG - 350	116	193	579	4.0	
	575	128	150	175	225	175	225	# 2 - 4/0	# 6 AWG - 350	# 6 AWG - 350	93	154	463	3.1	
0150EC	200	402	400	500	700	500	700	(2) # 1 - 500	(2) 3/0-250	(3) 2/0-400	295	656	1969	8.2	
	230	351	400	450	700	450	700	(2) # 2 - 300	(2) 3/0-250	(3) 2/0-400	256	571	1712	7.8	
	380	213	250	300	400	300	400	# 1 - 500	# 6 AWG - 350	(2) 3/0-250	155	360	1081	4.8	
	460	176	200	225	350	225	350	# 2 - 300	# 6 AWG - 350	# 6 AWG - 350	128	285	856	4.0	
	575	141	150	175	250	175	250	# 2 - 4/0	# 6 AWG - 350	# 6 AWG - 350	103	238	715	3.1	
0160EC	200	402	400	500	700	500	700	(2) # 1 - 500	(2) 3/0-250	(3) 2/0-400	295	656	1969	8.2	
	230	351	400	450	700	450	700	(2) # 2 - 300	(2) 3/0-250	(3) 2/0-400	256	571	1712	7.8	
	380	213	250	300	400	300	400	# 1 - 500	# 6 AWG - 350	(2) 3/0-250	155	360	1081	4.8	
	460	176	200	225	350	225	350	# 2 - 300	# 6 AWG - 350	# 6 AWG - 350	128	285	856	4.0	
	575	141	150	175	250	175	250	# 2 - 4/0	# 6 AWG - 350	# 6 AWG - 350	103	238	715	3.1	
0170EC	200	434	600	600	800	600	800	(2) # 1 - 500	(3) 2/0-400	(3) 2/0-400	321	656	1969	8.2	
	230	380	400	450	700	450	700	(2) # 1 - 500	(2) 3/0-250	(3) 2/0-400	279	571	1712	7.8	
	380	230	250	300	400	300	400	# 1 - 500	# 6 AWG - 350	(2) 3/0-250	169	360	1081	4.8	
	460	191	200	250	350	250	350	# 2 - 300	# 6 AWG - 350	# 6 AWG - 350	140	285	856	4.0	
	575	152	150	200	300	200	300	# 2 - 4/0	# 6 AWG - 350	# 6 AWG - 350	112	238	715	3.1	
0180EC	200	434	600	600	800	600	800	(2) # 1 - 500	(3) 2/0-400	(3) 2/0-400	321	656	1969	8.2	
	230	380	400	450	700	450	700	(2) # 1 - 500	(2) 3/0-250	(3) 2/0-400	279	571	1712	7.8	
	380	230	250	300	400	300	400	# 1 - 500	# 6 AWG - 350	(2) 3/0-250	169	360	1081	4.8	
	460	191	200	250	350	250	350	# 2 - 300	# 6 AWG - 350	# 6 AWG - 350	140	285	856	4.0	
	575	152	150	200	300	200	300	# 2 - 4/0	# 6 AWG - 350	# 6 AWG - 350	112	238	715	3.1	
0200EC	200	469	600	600	1000	600	1000	(2) # 1 - 500	(3) 2/0-400	(3) 2/0-400	342	656	1969	8.2	
	230	412	400	500	800	500	800	(2) # 1 - 500	(2) 3/0-250	(3) 2/0-400	298	571	1712	7.8	
	380	250	250	300	450	300	450	# 1 - 500	# 6 AWG - 350	(2) 3/0-250	181	360	1081	4.8	
	460	206	200	250	400	250	400	# 1 - 500	# 6 AWG - 350	# 6 AWG - 350	149	285	856	4.0	
	575	164	200	200	300	200	300	# 2 - 300	# 6 AWG - 350	# 6 AWG - 350	119	238	715	3.1	
0210EC	200	509	600	700	1000	700	1000	(2) # 1 - 500	(3) 2/0-400	(3) 2/0-400	374	656	1969	8.2	
	230	445	600	600	800	600	800	(2) # 1 - 500	(3) 2/0-400	(3) 2/0-400	325	571	1712	7.8	
	380	270	400	350	500	350	500	# 1 - 500	(2) 3/0-250	(2) 3/0-250	197	360	1081	4.8	
	460	224	250	300	400	300	400	# 1 - 500	# 6 AWG - 350	(2) 3/0-250	163	285	856	4.0	
	575	178	200	225	350	225	350	# 2 - 300	# 6 AWG - 350	# 6 AWG - 350	130	238	715	3.1	
0230EC	200	509	600	700	1000	700	1000	(2) # 1 - 500	(3) 2/0-400	(3) 2/0-400	374	656	1969	8.2	
	230	445	600	600	800	600	800	(2) # 1 - 500	(3) 2/0-400	(3) 2/0-400	325	571	1712	7.8	
	380	270	400	350	500	350	500	# 1 - 500	(2) 3/0-250	(2) 3/0-250	197	360	1081	4.8	
	460	224	250	300	400	300	400	# 1 - 500	# 6 AWG - 350	(2) 3/0-250	163	285	856	4.0	
	575	178	200	225	350	225	350	# 2 - 300	# 6 AWG - 350	# 6 AWG - 350	130	238	715	3.1	

See page 6 for notes.

MODEL YCAS	VOLTS	SYSTEM #2 FIELD-SUPPLIED WIRING												
		MCA ¹	MIN NF DISC SW ²	D.E. FUSE		C.B.		FACTORY PROVIDED (LUGS) WIRE RANGE ⁷			COMPRESSOR			FANS
				MIN. ³	MAX. ⁴	MIN. ³	MAX. ⁴	STD. TERMINAL BLOCK	OPT. NF SVC. DISC SW.	OPT. C.B.	RLA	Y-LRA	X-LRA	FLA (EA)
0130EC	200	340	400	450	600	450	600	(2) # 2 - 300	(2) 3/0-250	(3) 2/0-400	246	444	1332	8.2
	230	299	400	400	600	400	600	(2) # 2 - 300	(2) 3/0-250	(2) 3/0-250	214	386	1158	7.8
	380	181	200	225	350	225	350	# 2 - 300	# 6 AWG - 350	# 6 AWG - 350	130	234	701	4.8
	460	150	150	200	300	200	300	# 2 - 4/0	# 6 AWG - 350	# 6 AWG - 350	107	193	579	4.0
	575	119	150	150	225	150	225	# 2 - 4/0	# 6 AWG - 350	# 6 AWG - 350	86	154	463	3.1
0140EC	200	366	400	450	700	450	700	(2) # 2 - 300	(2) 3/0-250	(3) 2/0-400	267	444	1332	8.2
	230	321	400	400	600	400	600	(2) # 2 - 300	(2) 3/0-250	(2) 3/0-250	232	386	1158	7.8
	380	195	200	250	350	250	350	# 2 - 300	# 6 AWG - 350	# 6 AWG - 350	140	234	701	4.8
	460	161	200	200	300	200	300	# 2 - 300	# 6 AWG - 350	# 6 AWG - 350	116	193	579	4.0
	575	128	150	175	225	175	225	# 2 - 4/0	# 6 AWG - 350	# 6 AWG - 350	93	154	463	3.1
0150EC	200	363	400	450	700	450	700	(2) # 2 - 300	(2) 3/0-250	(3) 2/0-400	265	444	1332	8.2
	230	319	400	400	600	400	600	(2) # 2 - 300	(2) 3/0-250	(2) 3/0-250	230	386	1158	7.8
	380	193	200	250	350	250	350	# 2 - 300	# 6 AWG - 350	# 6 AWG - 350	139	234	701	4.8
	460	160	150	200	300	200	300	# 2 - 300	# 6 AWG - 350	# 6 AWG - 350	115	193	579	4.0
	575	127	150	175	225	175	225	# 2 - 4/0	# 6 AWG - 350	# 6 AWG - 350	92	154	463	3.1
0160EC	200	402	400	500	700	500	700	(2) # 1 - 500	(2) 3/0-250	(3) 2/0-400	295	656	1969	8.2
	230	351	400	450	700	450	700	(2) # 2 - 300	(2) 3/0-250	(3) 2/0-400	256	571	1712	7.8
	380	213	200	300	400	300	400	# 1 - 500	# 6 AWG - 350	(2) 3/0-250	155	360	1081	4.8
	460	176	200	225	350	225	350	# 2 - 300	# 6 AWG - 350	# 6 AWG - 350	128	285	856	4.0
	575	141	150	175	250	175	250	# 2 - 4/0	# 6 AWG - 350	# 6 AWG - 350	103	238	715	3.1
0170EC	200	402	400	500	700	500	700	(2) # 1 - 500	(2) 3/0-250	(3) 2/0-400	295	656	1969	8.2
	230	351	400	450	700	450	700	(2) # 2 - 300	(2) 3/0-250	(3) 2/0-400	256	571	1712	7.8
	380	213	200	300	400	300	400	# 1 - 500	# 6 AWG - 350	(2) 3/0-250	155	360	1081	4.8
	460	176	200	225	350	225	350	# 2 - 300	# 6 AWG - 350	# 6 AWG - 350	128	285	856	4.0
	575	141	150	175	250	175	250	# 2 - 4/0	# 6 AWG - 350	# 6 AWG - 350	103	238	715	3.1
0180EC	200	434	600	600	800	600	800	(2) # 1 - 500	(3) 2/0-400	(3) 2/0-400	321	656	1969	8.2
	230	380	400	450	700	450	700	(2) # 1 - 500	(2) 3/0-250	(3) 2/0-400	279	571	1712	7.8
	380	230	250	300	400	300	400	# 1 - 500	# 6 AWG - 350	(2) 3/0-250	169	360	1081	4.8
	460	191	200	250	350	250	350	# 2 - 300	# 6 AWG - 350	# 6 AWG - 350	140	285	856	4.0
	575	152	150	200	300	200	300	# 2 - 4/0	# 6 AWG - 350	# 6 AWG - 350	112	238	715	3.1
0200EC	200	469	600	600	1000	600	1000	(2) # 1 - 500	(3) 2/0-400	(3) 2/0-400	342	656	1969	8.2
	230	412	400	500	800	500	800	(2) # 1 - 500	(2) 3/0-250	(3) 2/0-400	298	571	1712	7.8
	380	250	250	300	450	300	450	# 1 - 500	# 6 AWG - 350	(2) 3/0-250	181	360	1081	4.8
	460	206	200	250	400	250	400	# 1 - 500	# 6 AWG - 350	# 6 AWG - 350	149	285	856	4.0
	575	164	200	200	300	200	300	# 2 - 300	# 6 AWG - 350	# 6 AWG - 350	119	238	715	3.1
0210EC	200	469	600	600	1000	600	1000	(2) # 1 - 500	(3) 2/0-400	(3) 2/0-400	342	656	1969	8.2
	230	412	400	500	800	500	800	(2) # 1 - 500	(2) 3/0-250	(3) 2/0-400	298	571	1712	7.8
	380	250	250	300	450	300	450	# 1 - 500	# 6 AWG - 350	(2) 3/0-250	181	360	1081	4.8
	460	206	200	250	400	250	400	# 1 - 500	# 6 AWG - 350	# 6 AWG - 350	149	285	856	4.0
	575	164	200	200	300	200	300	# 2 - 300	# 6 AWG - 350	# 6 AWG - 350	119	238	715	3.1
0230EC	200	509	600	700	1000	700	1000	(2) # 1 - 500	(3) 2/0-400	(3) 2/0-400	374	656	1969	8.2
	230	445	600	600	800	600	800	(2) # 1 - 500	(3) 2/0-400	(3) 2/0-400	325	571	1712	7.8
	380	270	400	350	500	350	500	# 1 - 500	(2) 3/0-250	(2) 3/0-250	197	360	1081	4.8
	460	224	250	300	400	300	400	# 1 - 500	# 6 AWG - 350	(2) 3/0-250	163	285	856	4.0
	575	178	200	225	350	225	350	# 2 - 300	# 6 AWG - 350	# 6 AWG - 350	130	238	715	3.1

ELECTRICAL DATA (Continued)

OPTIONAL SINGLE-POINT POWER SUPPLY WITH INTERNAL CIRCUIT BREAKERS

(One Field Provided Power Supply Circuit to the chiller. Field connections to Power Terminal Block or Non-Fused Disconnect in 'Option Panel'.
Internal Branch Circuit Protection (Breakers) per Motor Control Center)

MODEL YCAS	VOLTS	FIELD-SUPPLIED WIRING									
		FIELD PROVIDED POWER SUPPLY						FACTORY PROVIDED (LUGS) WIRE RANGE			
		MCA ¹	MIN NF DISC SW ²	D.E. FUSE		C.B.		TERMINAL BLOCK		NF SERVICE DISC SW	
				MIN. ³	MAX. ⁴	MIN. ³	MAX. ⁴	(LUGS) WIRE RANGE ⁷	RATING ²	(LUGS) WIRE RANGE ⁷	RATING ²
0130EC	200	619	800	700	1000	700	1000	(3) # 1 - 500	1140	(3) 2/0-400	800
	230	544	600	600	800	600	800	(2) # 1 - 500	760	(3) 2/0-400	600
	380	330	400	400	500	400	500	(2) # 2 - 300	550	(2) 3/0-250	400
	460	273	400	300	400	300	400	# 1 - 500	380	(2) 3/0-250	400
	575	217	250	250	350	250	350	# 1 - 500	380	# 6 AWG - 350	250
0140EC	200	666	800	800	1000	800	1000	(3) # 1 - 500	1140	(3) 2/0-400	800
	230	584	800	700	1000	700	1000	(3) # 1 - 500	1140	(3) 2/0-400	600
	380	354	400	400	500	400	500	(2) # 2 - 300	550	(2) 3/0-250	400
	460	293	400	350	450	350	450	(2) # 2 - 300	550	(2) 3/0-250	400
	575	234	250	300	350	300	350	# 1 - 500	380	# 6 AWG - 350	250
0150EC	200	699	800	800	1000	800	1000	(3) # 1 - 500	1140	(3) 2/0-400	800
	230	612	800	700	1000	700	1000	(3) # 1 - 500	1140	(3) 2/0-400	800
	380	371	400	450	600	450	600	(2) # 1 - 500	760	(2) 3/0-250	400
	460	307	400	350	450	350	450	(2) # 2 - 300	550	(2) 3/0-250	400
	575	246	400	300	350	300	350	# 1 - 500	380	(2) 3/0-250	400
0160EC	200	729	800	1000	1200	1000	1200	(3) # 1 - 500	1140	(3) 2/0-400	800
	230	638	800	800	1000	800	1000	(3) # 1 - 500	1140	(3) 2/0-400	800
	380	387	600	450	600	450	600	(2) # 1 - 500	760	(3) 2/0-400	600
	460	320	400	400	450	400	450	(2) # 2 - 300	550	(2) 3/0-250	400
	575	257	400	300	400	300	400	# 1 - 500	380	(2) 3/0-250	400
0170EC	200	762	800	1000	1200	1000	1200	(3) # 1 - 500	1140	(3) 2/0-400	800
	230	667	800	800	1000	800	1000	(3) # 1 - 500	1140	(3) 2/0-400	800
	380	405	600	450	600	450	600	(2) # 1 - 500	760	(3) 2/0-400	600
	460	335	400	400	500	400	500	(2) # 2 - 300	550	(2) 3/0-250	400
	575	268	400	300	400	300	400	# 1 - 500	380	(2) 3/0-250	400
0180EC	200	788	1000	1000	1200	1000	1200	(3) # 1 - 500	1140	(4) 4/0-500	1000
	230	690	800	800	1000	800	1000	(3) # 1 - 500	1140	(3) 2/0-400	800
	380	419	600	500	600	500	600	(2) # 1 - 500	760	(3) 2/0-400	600
	460	347	400	400	500	400	500	(2) # 2 - 300	550	(2) 3/0-250	400
	575	277	400	350	400	350	400	(2) # 2 - 300	550	(2) 3/0-250	400
0200EC	200	852	1000	1000	1200	1000	1200	(3) # 1 - 500	1140	(4) 4/0-500	1000
	230	749	800	1000	1200	1000	1200	(3) # 1 - 500	1140	(3) 2/0-400	800
	380	455	600	600	700	600	700	(2) # 1 - 500	760	(3) 2/0-400	600
	460	375	400	450	600	450	600	(2) # 1 - 500	760	(2) 3/0-250	400
	575	299	400	350	450	350	450	(2) # 2 - 300	550	(2) 3/0-250	400
0210EC	200	892	1000	1000	1600	1000	1600	(3) # 1 - 500	1140	(4) 4/0-500	1000
	230	782	1000	1000	1200	1000	1200	(3) # 1 - 500	1140	(4) 4/0-500	1000
	380	475	600	600	700	600	700	(2) # 1 - 500	760	(3) 2/0-400	600
	460	393	600	450	600	450	600	(2) # 1 - 500	760	(3) 2/0-400	600
	575	313	400	350	450	350	450	(2) # 2 - 300	550	(2) 3/0-250	400
0230EC	200	924	1000	1200	1600	1200	1600	(3) # 1 - 500	1140	(4) 4/0-500	1000
	230	809	1000	1000	1200	1000	1200	(3) # 1 - 500	1140	(4) 4/0-500	1000
	380	491	600	600	700	600	700	(2) # 1 - 500	760	(3) 2/0-400	600
	460	407	600	450	600	450	600	(2) # 1 - 500	760	(3) 2/0-400	600
	575	324	400	400	500	400	500	(2) # 2 - 300	550	(2) 3/0-250	400

See page 6 for notes.

MODEL YCAS	VOLTS	SYSTEM #1					SYSTEM #2				
		FACTORY C.B.	COMPRESSOR DATA			FAN DATA	FACTORY C.B.	COMPRESSOR DATA			FAN DATA
			RLA	Y-LRA	X-LRA	FLA (EA)		RLA	Y-LRA	X-LRA	FLA (EA)
0130EC	200	600	246	444	1332	8.2	600	246	444	1332	8.2
	230	400	214	386	1158	7.8	400	214	386	1158	7.8
	380	250	130	234	701	4.8	250	130	234	701	4.8
	460	250	107	193	579	4.0	250	107	193	579	4.0
	575	160	86	154	463	3.1	160	86	154	463	3.1
0140EC	200	600	267	444	1332	8.2	600	267	444	1332	8.2
	230	400	232	386	1158	7.8	400	232	386	1158	7.8
	380	250	140	234	701	4.8	250	140	234	701	4.8
	460	250	116	193	579	4.0	250	116	193	579	4.0
	575	160	93	154	463	3.1	160	93	154	463	3.1
0150EC	200	600	295	656	1969	8.2	600	265	444	1332	8.2
	230	600	256	571	1712	7.8	400	230	386	1158	7.8
	380	400	155	360	1081	4.8	250	139	234	701	4.8
	460	250	128	285	856	4.0	250	115	193	579	4.0
	575	250	103	238	715	3.1	160	92	154	463	3.1
0160EC	200	600	295	656	1969	8.2	600	295	656	1969	8.2
	230	600	256	571	1712	7.8	600	256	571	1712	7.8
	380	400	155	360	1081	4.8	400	155	360	1081	4.8
	460	250	128	285	856	4.0	250	128	285	856	4.0
	575	250	103	238	715	3.1	250	103	238	715	3.1
0170EC	200	600	321	656	1969	8.2	600	295	656	1969	8.2
	230	600	279	571	1712	7.8	600	256	571	1712	7.8
	380	400	169	360	1081	4.8	400	155	360	1081	4.8
	460	250	140	285	856	4.0	250	128	285	856	4.0
	575	250	112	238	715	3.1	250	103	238	715	3.1
0180EC	200	600	321	656	1969	8.2	600	321	656	1969	8.2
	230	600	279	571	1712	7.8	600	279	571	1712	7.8
	380	400	169	360	1081	4.8	400	169	360	1081	4.8
	460	250	140	285	856	4.0	250	140	285	856	4.0
	575	250	112	238	715	3.1	250	112	238	715	3.1
0200EC	200	600	342	656	1969	8.2	600	342	656	1969	8.2
	230	600	298	571	1712	7.8	600	298	571	1712	7.8
	380	400	181	360	1081	4.8	400	181	360	1081	4.8
	460	250	149	285	856	4.0	250	149	285	856	4.0
	575	250	119	238	715	3.1	250	119	238	715	3.1
0210EC	200	600	374	656	1969	8.2	600	342	656	1969	8.2
	230	600	325	571	1712	7.8	600	298	571	1712	7.8
	380	400	197	360	1081	4.8	400	181	360	1081	4.8
	460	400	163	285	856	4.0	250	149	285	856	4.0
	575	250	130	238	715	3.1	250	119	238	715	3.1
0230EC	200	600	374	656	1969	8.2	600	374	656	1969	8.2
	230	600	325	571	1712	7.8	600	325	571	1712	7.8
	380	400	197	360	1081	4.8	400	197	360	1081	4.8
	460	400	163	285	856	4.0	400	163	285	856	4.0
	575	250	130	238	715	3.1	250	130	238	715	3.1

ELECTRICAL DATA (Continued)

OPTIONAL SINGLE POINT POWER SUPPLY CONNECTION TO FACTORY CIRCUIT BREAKER

(One Field Provided Power Supply Circuit to the chiller. Field Connection to Circuit Breaker in 'Option Panel'.
No internal Branch Circuit Protection per Motor Control Center.)

MODEL YCAS	VOLTS	FIELD SUPPLIED WIRING			SYSTEM #1			SYSTEM #2		
		MCA ¹	FACTORY SUPPLIED BREAKER		COMPRESSOR		FANS	COMPRESSOR		FANS
			RATING ²	WIRE RANGE ⁷ (LUGS)	RLA	X-LRA	FLA (EA)	RLA	X-LRA	FLA (EA)
0130EC	460	273	400	(2) 3/0-250	107	579	4.0	107	579	4.0
	575	217	250	# 6 AWG - 350	86	463	3.1	86	463	3.1
0140EC	460	293	400	(2) 3/0-250	116	579	4.0	116	579	4.0
	575	234	400	(2) 3/0-250	93	463	3.1	93	463	3.1
0150EC	460	307	400	(2) 3/0-250	128	856	4.0	115	579	4.0
	575	246	400	(2) 3/0-250	103	715	3.1	92	463	3.1
0160EC	460	320	400	(2) 3/0-250	128	856	4.0	128	856	4.0
	575	257	400	(2) 3/0-250	103	715	3.1	103	715	3.1
0170EC	460	335	400	(2) 3/0-250	140	856	4.0	128	856	4.0
	575	268	400	(2) 3/0-250	112	715	3.1	103	715	3.1
0180EC	460	347	400	(2) 3/0-250	140	856	4.0	140	856	4.0
	575	277	400	(2) 3/0-250	112	715	3.1	112	715	3.1
0200EC	460	375	630	(3) 2/0-400	149	856	4.0	149	856	4.0
	575	299	400	(2) 3/0-250	119	715	3.1	119	715	3.1
0210EC	460	393	630	(3) 2/0-400	163	856	4.0	149	856	4.0
	575	313	400	(2) 3/0-250	130	715	3.1	119	715	3.1
0230EC	460	407	630	(3) 2/0-400	163	856	4.0	163	856	4.0
	575	324	400	(2) 3/0-250	130	715	3.1	130	715	3.1

NOTE: Wye-Delta Compressor Start not available with this option.

NOTES (pages 2 - 7)

- Minimum circuit ampacity (MCA) is based on 125% of the rated load amps for the largest motor plus 100% of the rated load amps for all other loads included in the circuit, per N.E.C. Article 430-24. If a Factory Mounted Control Transformer is provided, add the following to the system #2 MCA values in the YCAS Tables: -17, add 10 amps; -28, add 9 amps; -40, add 5 amps; -46, add 4 amps; -58, add 3 amps.
- The recommendation disconnect switch is based on a minimum of 115% of the summation rated load amps of all the loads included in the circuit, per N.E.C. 440 - 12A1.
- Minimum fuse size is based on 150% of the largest motor RLA plus 100% of the remaining RLAs (U.L. Standard 1995, Section 36.1). Minimum fuse rating = (1.5 x largest compressor RLA) + other compressor RLAs + (# fans x each fan motor FLA).
- Maximum dual element fuse size is based on 225% maximum plus 100% of the rated load amps for all other loads included in the circuit, per N.E.C. 440-22. Maximum fuse rating = (2.25 x largest compressor RLA) + other compressor RLAs + (# fans x each fan motor FLA).
- Minimum circuit breaker is 150% maximum plus 100% of rated load amps included in the circuit, per circuit per U.L. 1995 Fig. 36.2. Minimum circuit breaker rating = (1.5 x largest compressor RLA) + other compressor RLAs + (# fans x each fan motor FLA).
- Maximum circuit breaker is based on 225% maximum plus 100% of the rated load amps for all loads included in the circuit, per circuit, per U.L. 1995 Fig. 36.2. Maximum circuit breaker rating = (2.25 x largest compressor RLA) + other compressor RLAs + (# fans x each fan motor FLA).
- The Incoming Wire Range is the minimum and maximum wire size that can be accommodated by unit wiring lugs. The (1), (2), or (3) indicate the number of termination points or lugs which are available per phase. Actual wire size and number of wires per phase must be determined based on ampacity and job requirements using N.E.C. wire sizing information. The above recommendations are based on the National Electric Code and using copper connectors only. Field wiring must also comply with local codes.
- A ground lug is provided for each compressor system to accommodate field grounding conductor per N.E.C. Article 250-54. A control circuit grounding lug is also supplied. Incoming ground wire range is #6 - 350 MCM.
- The field supplied disconnect is a "Disconnecting Means" as defined in N.E.C. 100.B, and is intended for isolating the unit from the available power supply to perform maintenance and troubleshooting. This disconnect is not intended to be a Load Break Device.
- Units equipped with Star-Delta compressor motor start must also include Factory provided circuit breakers in each motor control center.
- The wiring recommendations are based on the National Electrical Code using copper connectors only. Field wiring must also comply with local codes.

OPTIONAL SINGLE POINT POWER SUPPLY CONNECTION WITH FIELD SUPPLIED CIRCUIT PROTECTION

(One Field Provided Power Supply Circuit to the chiller. Field Connection to Power Terminal Block or Disconnect Switch in the 'Option Panel'.
No internal Branch Circuit Protection per Motor Control Center.)

MODEL YCAS	VOLTS	FIELD SUPPLIED WIRING							SYSTEM #1			SYSTEM #2		
		FIELD PROVIDED POWER SUPPLY			FACTORY PROVIDED (LUGS) WIRE RANGE				COMPRESSOR DATA		FANS DATA	COMPRESSOR DATA		FANS DATA
		MCA ¹	MIN NF DISC SW ²	D.E. FUSE	TERMINAL BLOCK (LUGS) WIRE RANGE	RATING ²	NF SERV DISC SW (LUGS) WIRE RANGE ⁷	RLA	X-LRA	FLA (EA)	RLA	X-LRA	FLA (EA)	
0130EC	460	273	400	300	400	# 1 - 500	400	(2) 3/0-250	107	579	4.0	107	579	4.0
	575	217	250	250	350	# 1 - 500	250	# 6 AWG - 350	86	463.2	3.1	86	463	3.1
0140EC	460	293	400	350	450	(2) # 2 - 300	400	(2) 3/0-250	116	579	4.0	116	579	4.0
	575	234	250	300	350	# 1 - 500	250	# 6 AWG - 350	93	463.2	3.1	93	463	3.1
0150EC	460	307	400	350	450	(2) # 2 - 300	400	(2) 3/0-250	128	856	4.0	115	579	4.0
	575	246	400	300	350	# 1 - 500	250	# 6 AWG - 350	103	715	3.1	92	463	3.1
0160EC	460	320	400	400	450	(2) # 2 - 300	400	(2) 3/0-250	128	856	4.0	128	856	4.0
	575	257	400	300	400	# 1 - 500	400	(2) 3/0-250	103	715	3.1	103	715	3.1
0170EC	460	335	400	400	500	(2) # 2 - 300	400	(2) 3/0-250	140	856	4.0	128	856	4.0
	575	268	400	300	400	# 1 - 500	400	(2) 3/0-250	112	715	3.1	103	715	3.1
0180EC	460	347	400	400	500	(2) # 2 - 300	400	(2) 3/0-250	140	856	4.0	140	856	4.0
	575	277	400	350	400	(2) # 2 - 300	400	(2) 3/0-250	112	715	3.1	112	715	3.1
0200EC	460	375	400	450	600	(2) # 1 - 500	400	(2) 3/0-250	149	856	4.0	149	856	4.0
	575	299	400	350	450	(2) # 2 - 300	400	(2) 3/0-250	119	715	3.1	119	715	3.1
0210EC	460	393	600	450	600	(2) # 1 - 500	400	(2) 3/0-250	163	856	4.0	149	856	4.0
	575	313	400	350	450	(2) # 2 - 300	400	(2) 3/0-250	130	715	3.1	119	715	3.1
0230EC	460	407	600	450	600	(2) # 1 - 500	630	(3) 2/0-400	163	856	4.0	163	856	4.0
	575	324	400	400	500	(2) # 2 - 300	400	(2) 3/0-250	130	715	3.1	130	715	3.1

LEGEND

ACR-LINE	ACROSS THE LINE START
C.B.	CIRCUIT BREAKER
D.E.	DUAL ELEMENT FUSE
DISC SW	DISCONNECT SWITCH
FACT MOUNT CB	FACTORY-MOUNTED CIRCUIT BREAKER
FLA	FULL LOAD AMPS
HZ	HERTZ
MAX	MAXIMUM
MCA	MINIMUM CIRCUIT AMPACITY
MIN	MINIMUM
MIN NF	MINIMUM NON-FUSED
RLA	RUNNING LOAD AMPS
S.P. WIRE	SINGLE-POINT WIRING
UNIT MTD SERV SW	UNIT-MOUNTED SERVICE (NON-FUSED DISCONNECT SWITCH)
WYE-DELTA	WYE-DELTA START
X-LRA	ACROSS-THE-LINE INRUSH LOCKED ROTOR AMPS
Y-LRA	WYE-DELTA INRUSH LOCKED ROTOR AMPS

CONTROL POWER SUPPLY

UNIT VOLTAGE	CONTROL POWER SUPPLY	MIN CIRCUIT AMPACITY	MAX DUAL ELEMENT FUSE SIZE	NON-FUSED DISC. SW. SIZE
Standard Models w/o Transformers	115-1-60	20A	20A	30A

VOLTAGE CODE

- 17 = 200-3-60
- 28 = 230-3-60
- 40 = 380-3-60
- 46 = 460-3-60
- 58 = 575-3-60

WIRING DIAGRAM ACROSS-THE-LINE START

NOTES:

1. Field wiring to be in accordance with the current edition of the National Electrical Code as well as all other applicable codes and specifications.
2. Numbers along the right side of a diagram are line identification numbers. The numbers at each line indicate the line number location of relay contacts. An unlined contact location signifies a normally closed contact. Numbers adjacent to circuit lines are the circuit identification numbers.
3. Any customer supplied contacts must be suitable for switching 24VDC. (Gold contacts recommended.) Control Wiring must not be run in the same conduit with any line voltage wiring.
4. To cycle unit on and off automatically with contact shown, install a cycling device in series with the flow switch (FSLW). See Note 3 for contact rating and wiring specifications. Also refer to cautions on the following page.
5. To stop unit (Emergency Stop) with contacts other than those shown, install the stop contact between 5 and 1. If a stop device is not installed, a jumper must be connected between terminals 5 and 1. Device must have a minimum contact rating of 100VA at 115 volts A.C.
6. Alarm contacts are for annunciating alarm/unit malfunction. Contacts are rated at 115V, 100VA, resistive load only, and must be suppressed at load by user.
7. See Installation, Operation and Maintenance Manual when optional equipment is used.
8. Control panel to be securely connected to earth ground.
9. Us 2KVA transformer in optional transformer kit unless there are optional oil separator sump heaters which necessitates using a 3KVA transformer.

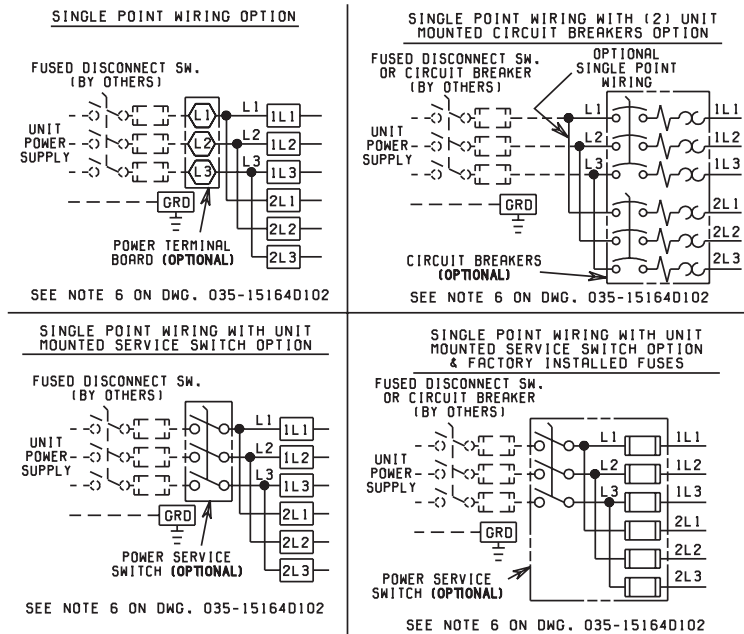

LD03226

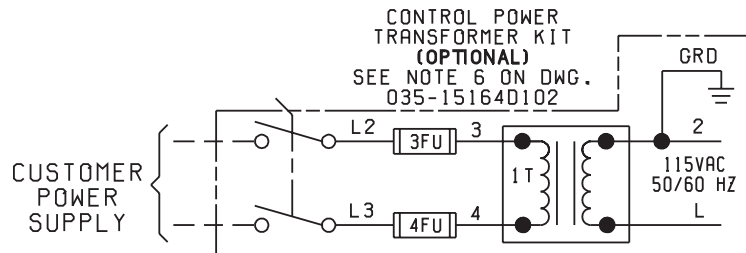

LD03227

LEGEND

- T S** Transient Voltage Suppression
- Terminal Block for Customer Connections
- Terminal Block for Customer Low Voltage (Class 2) Connections. See Note 2
- Terminal Block for YORK Connections Only
- Wiring and Components by YORK
- Optional Equipment
- Wiring and/or Components by Others

FIG. 1 – ELEMENTARY DIAGRAM – ACROSS-THE-LINE START

WIRING DIAGRAM ACROSS-THE-LINE START

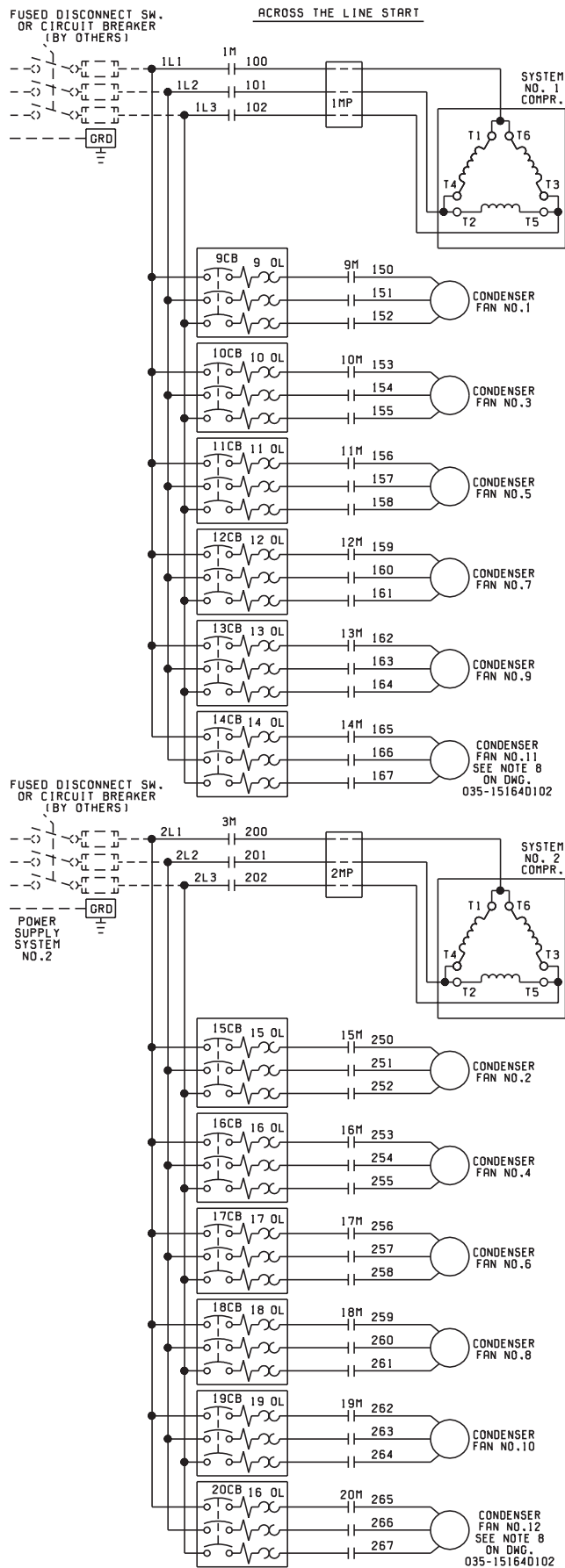

ELEMENTARY DIAGRAM

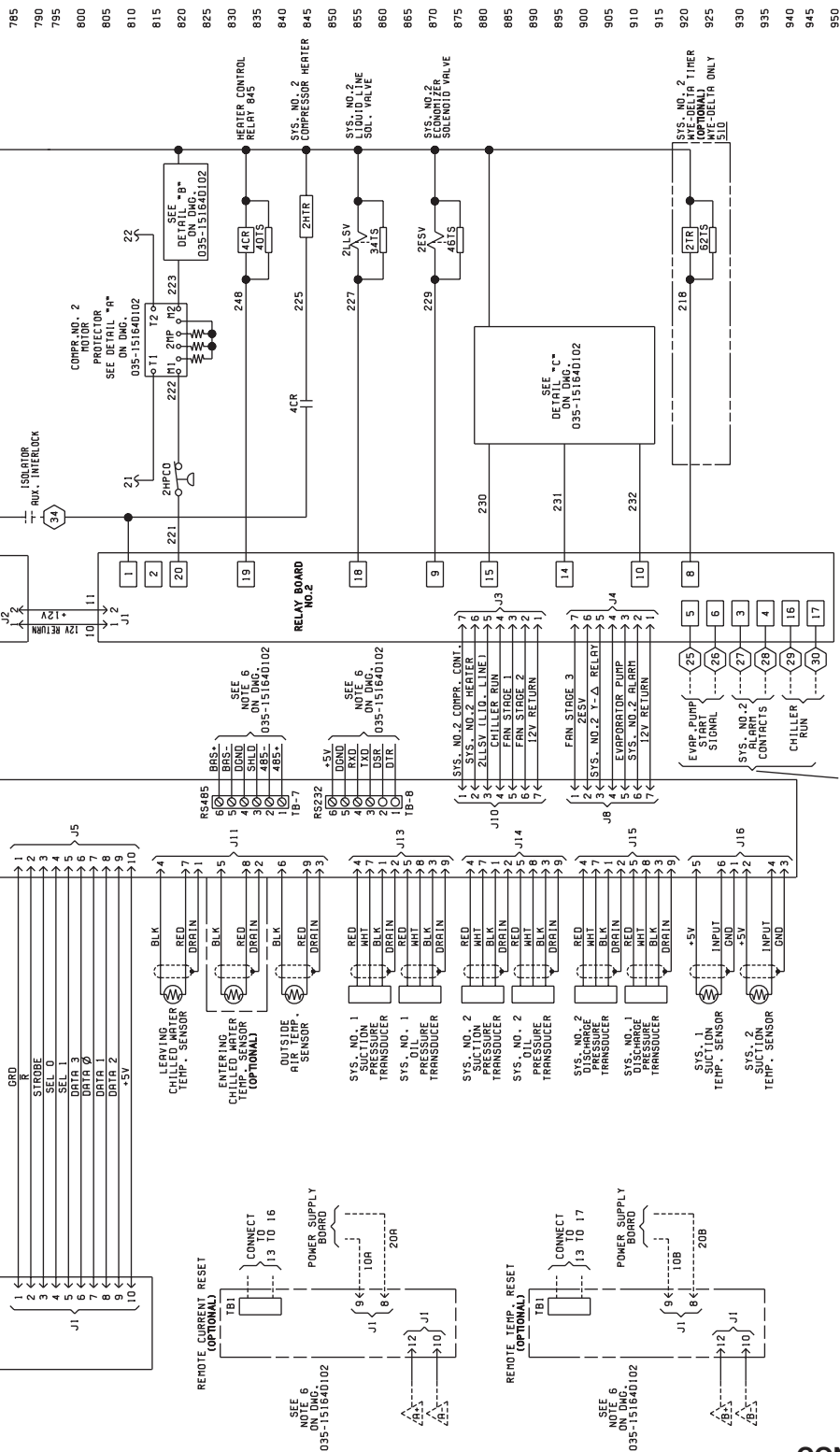

LD03279

CAUTION:
No Controls (relays, etc.) should be mounted in the Smart Panel enclosure or connected to power supplies in the control panel. Additionally, control wiring not connected to the Smart Panel should not be run through the cabinet. This could result in nuisance faults.

CAUTION:
Any inductive devices (relays) wired in series with the flow switch for start/stop, into the Alarm circuitry, or pilot relays for pump starters wired through motor contactor auxiliary contacts must be suppressed with YORK P/N 031-00808-000 suppressor across the relay/contactor coil.

Any contacts connected to flow switch inputs or BAS inputs on terminals 13 - 19 or TB3, or any other terminals, must be suppressed with a YORK P/N 031-00808-000 suppressor across the relay/contactor coil.

CAUTION:
Control wiring connected to the control panel should never be run in the same conduit with power wiring.

CONTROL POWER SUPPLY

UNIT VOLTAGE	CONTROL POWER SUPPLY	MIN CIRCUIT AMP.	MAX DUAL ELEMENT FUSE SIZE	NON-FUSED DISC. SWITCH SIZE	
ALL MODELS W/O TRANS.	115-1-50/60	20A	20A 250V	30A 240V	
MODELS WITH TRANS.	-17	200-1-60	15A	15A 250V	30A 240V
	-28	230-1-60	15A	15A 250V	30A 240V
	-46	400-1-60	8A	8A 600V	30A 480V
	-58	575-1-60	8A	8A 600V	30A 600V

* All primary and secondary wiring between transformer and control panel included.

WIRING DIAGRAM WYE-DELTA START

NOTES:

1. Field wiring to be in accordance with the current edition of the National Electrical Code as well as all other applicable codes and specifications.
2. Numbers along the right side of a diagram are line identification numbers. The numbers at each line indicate the line number location of relay contacts. An unlined contact location signifies a normally closed contact. Numbers adjacent to circuit lines are the circuit identification numbers.
3. Any customer supplied contacts must be suitable for switching 24VDC. (Gold contacts recommended.) Control Wiring must not be run in the same conduit with any line voltage wiring.
4. To cycle unit on and off automatically with contact shown, install a cycling device in series with the flow switch (FSLW). See Note 3 for contact rating and wiring specifications. Also refer to cautions on the following page.
5. To stop unit (Emergency Stop) with contacts other than those shown, install the stop contact between 5 and 1. If a stop device is not installed, a jumper must be connected between terminals 5 and 1. Device must have a minimum contact rating of 100VA at 115 volts A.C.
6. Alarm contacts are for annunciating alarm/unit malfunction. Contacts are rated at 115V, 100VA, resistive load only, and must be suppressed at load by user.
7. See Installation, Operation and Maintenance Manual when optional equipment is used.
8. Control panel to be securely connected to earth ground.
9. Us 2KVA transformer in optional transformer kit unless there are optional oil separator sump heaters which necessitates using a 3KVA transformer.

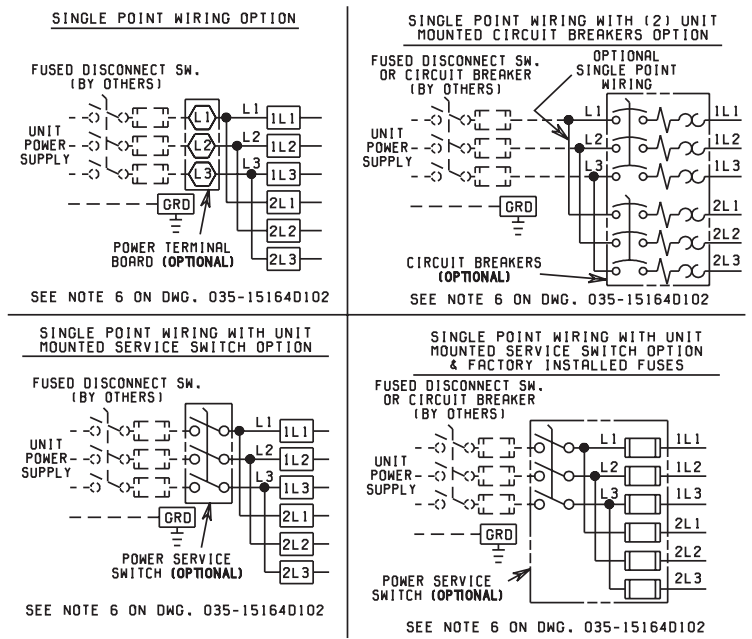

LD03226

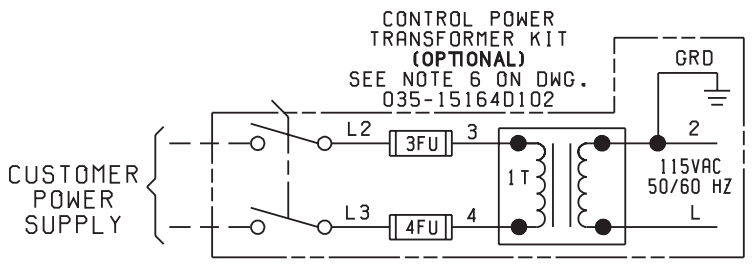

LD03227

LEGEND

- T S** Transient Voltage Suppression
- Terminal Block for Customer Connections
- Terminal Block for Customer Low Voltage (Class 2) Connections. See Note 2
- Terminal Block for YORK Connections Only
- Wiring and Components by YORK
- Optional Equipment
- Wiring and/or Components by Others

FIG. 1 – ELEMENTARY DIAGRAM – WYE-DELTA START

WIRING DIAGRAM WYE-DELTA START

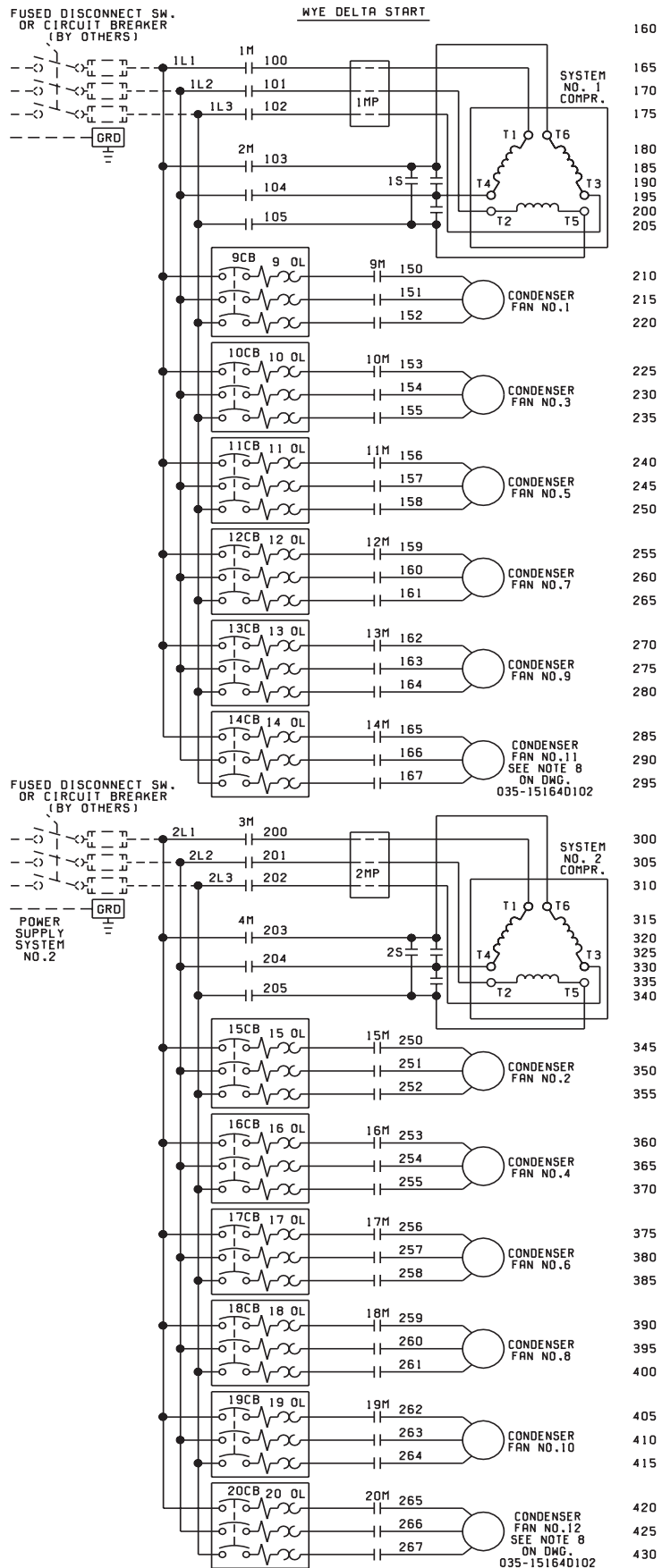

ELEMENTARY DIAGRAM

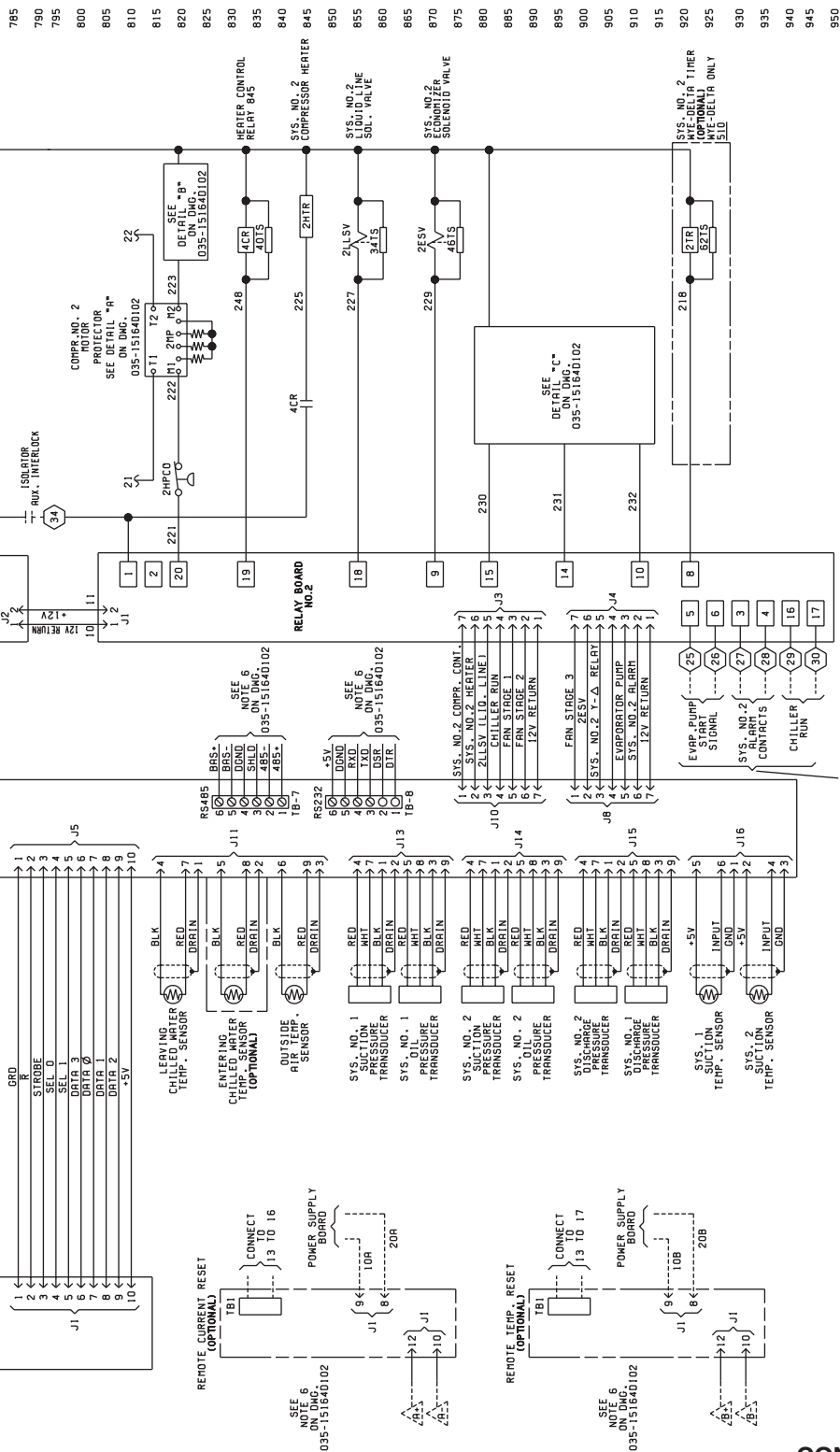

LD03279

CAUTION:
No Controls (relays, etc.) should be mounted in the Smart Panel enclosure or connected to power supplies in the control panel. Additionally, control wiring not connected to the Smart Panel should not be run through the cabinet. This could result in nuisance faults.

CAUTION:
Any inductive devices (relays) wired in series with the flow switch for start/stop, into the Alarm circuitry, or pilot relays for pump starters wired through motor contactor auxiliary contacts must be suppressed with YORK P/N 031-00808-000 suppressor across the relay/contactor coil.

Any contacts connected to flow switch inputs or BAS inputs on terminals 13 - 19 or TB3, or any other terminals, must be suppressed with a YORK P/N 031-00808-000 suppressor across the relay/contactor coil.

CAUTION:
Control wiring connected to the control panel should never be run in the same conduit with power wiring.

CONTROL POWER SUPPLY

UNIT VOLTAGE	CONTROL POWER SUPPLY	MIN CIRCUIT AMP.	MAX DUAL ELEMENT FUSE SIZE	NON-FUSED DISC. SWITCH SIZE	
ALL MODELS W/O TRANS.	115-1-50/60	20A	20A 250V	30A 240V	
MODELS WITH TRANS.	-17	200-1-60	15A	15A 250V	30A 240V
	-28	230-1-60	15A	15A 250V	30A 240V
	-46	400-1-60	8A	8A 600V	30A 480V
	-58	575-1-60	8A	8A 600V	30A 600V

* All primary and secondary wiring between transformer and control panel included.

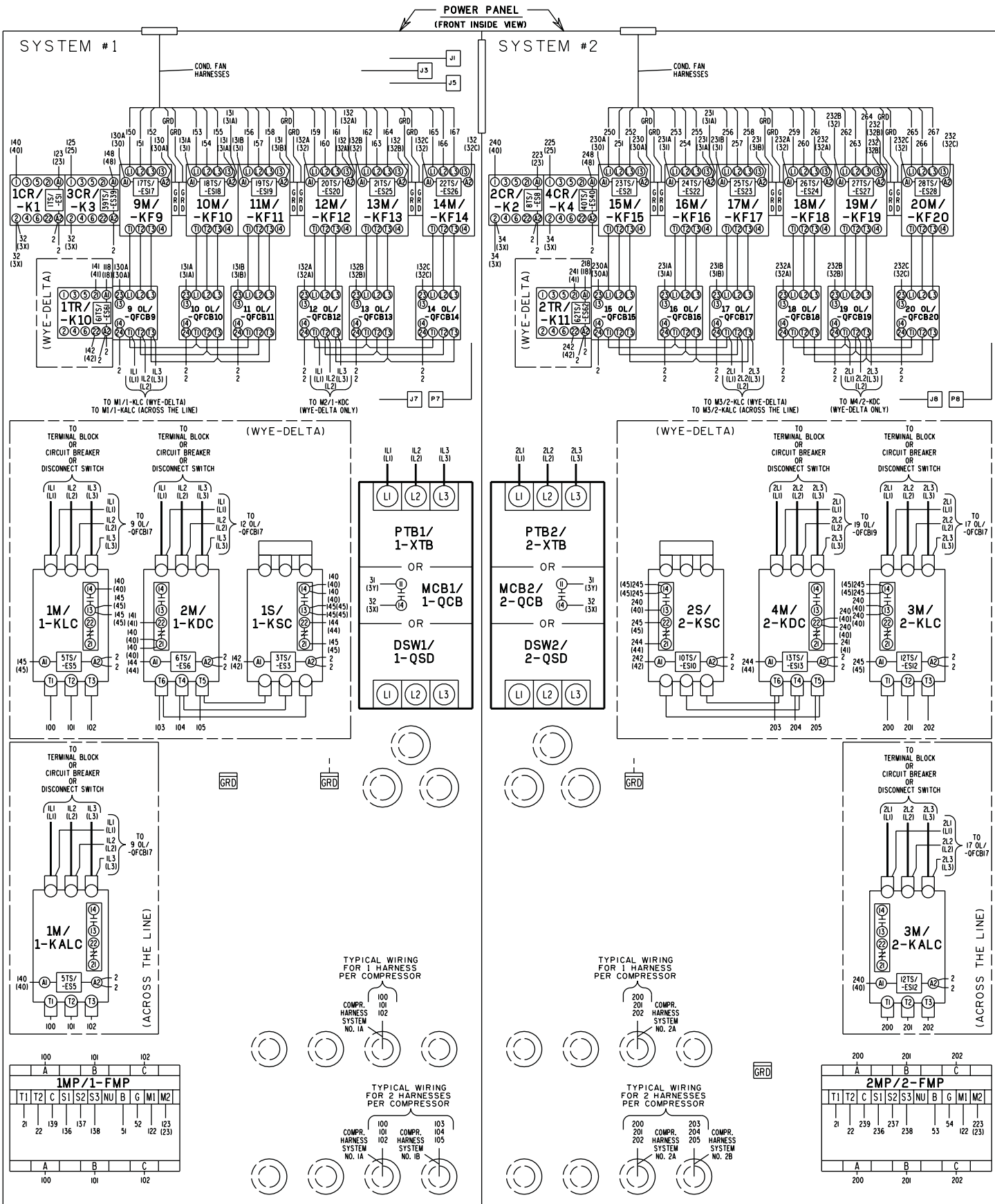

ELECTRONIC PANEL
(FRONT INSIDE VIEW)

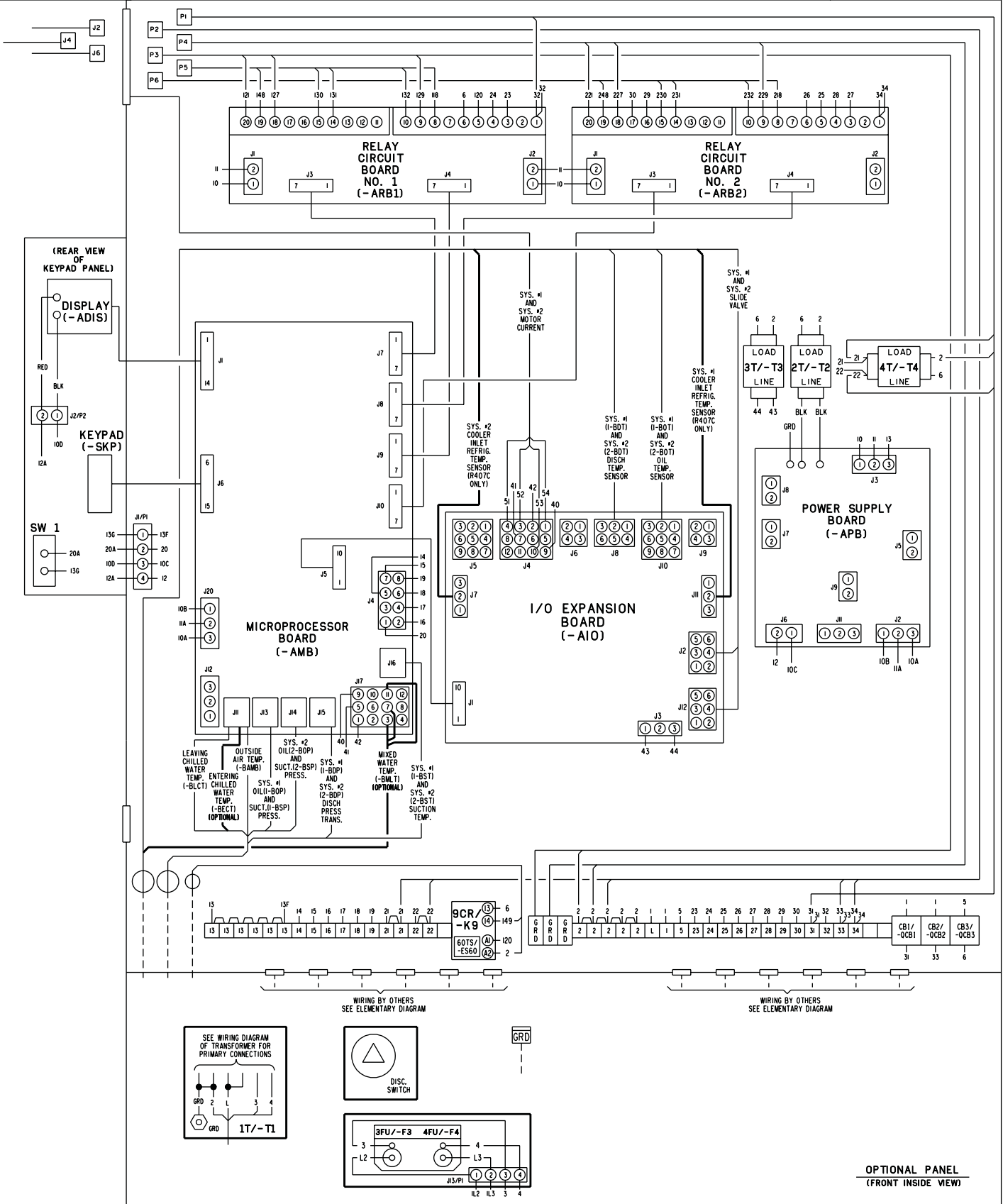

OPTIONAL PANEL
(FRONT INSIDE VIEW)

LEGEND

- 1CR THRU 4CR, 9CR/ -CONTROL RELAYS
- K1 THRU -K4, -K9 -CIRCUIT BREAKERS
- CB1, CB2, CB3/ -OVERLOAD CIRCUIT BREAKERS (SYS. #1)
- QCB1, -QBC2, -QCB3 9CB THRU 14CB -OVERLOAD CIRCUIT BREAKERS (SYS. #2)
- 15CB THRU 20CB -MOTOR OVERLOADS (SYS. #1)
- 9 OL THRU 14 OL -MOTOR OVERLOADS (SYS. #2)
- 15 OL THRU 20 OL -MOTOR OVERLOADS W/OVERLOAD CIRCUIT BREAKERS (SYS. #1)
- QFCB9 THRU -QFCB14 -MOTOR OVERLOADS W/OVERLOAD CIRCUIT BREAKERS (SYS. #2)
- QFCB15 THRU -QFCB20 -TRANSFORMER FUSE (OPTIONAL)
- 3FU, 4FU/ -F3, -F4
- 1M, 3M/ -COMPRESSOR CONTACTORS
- 1-KLC OR 1-KALC, 2-KLC OR 2-KALC -COMPRESSOR CONTACTORS
- 2M, 4M/ -COMPRESSOR CONTACTORS
- 1-KDC, 2-KDC -COMPRESSOR CONTACTORS
- 1S, 2S/ -COMPRESSOR CONTACTORS
- 1-KSC, 2-KSC -CONDENSER FAN CONTACTORS
- 9M THRU 14M/ -CONDENSER FAN CONTACTORS (SYS. #1)
- KF9 THRU -KF14 -CONDENSER FAN CONTACTORS (SYS. #2)
- 15M THRU 20M/ -KF15 THRU -KF20 -CONDENSER FAN CONTACTORS (SYS. #2)
- 1MP/1-FMP -MOTOR PROTECTOR (SYS. #1)
- 2MP/2-FMP -MOTOR PROTECTOR (SYS. #2)
- 1T/-T1 -CONTROL TRANSFORMER 2KVA (OPTIONAL)
- 2T, 3T, 4T/ -MICRO PANEL TRANSFORMERS
- T2, -T3, -T4
- 1TR, 2TR/ -TIMER RELAYS
- K10, -K11
- TS/-ES -TRANSIENT SUPPRESSORS
- PTB1, PTB2/ -POWER TERMINAL BLOCK
- 1-XTB, 2-XTB
- MCB1, MCB2/ -MOTOR CIRCUIT BREAKER
- 1-QCB, 2-QCB
- DSW1, DSW2/ -DISCONNECT SERVICE SWITCH
- 1-QSD, 2-QSD
- -WIRING BY YORK
- -WIRING BY OTHERS
- -OPTIONAL WIRING AND/OR COMPONENTS

CONNECTION DIAGRAM, ELEC. BOX DXST DIRECT DRIVE

J1, J2, J3, J4, J5, J6, J7, J8, P7 & P8 — POWER PANEL

P1, P2, P3, P4, P5, & P6 — ELECTRONIC (MICRO) PANEL

NOTE: WIRE NUMBERS IDENTIFIED IN (PARENTHESIS) INDICATE THE ACTUAL HARNESS CODE STAMPED ON THE WIRE.

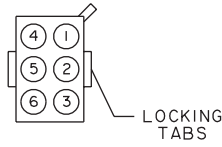

HOUSING - CONNECTOR (J1, J2, J5, & J6) WIRING END

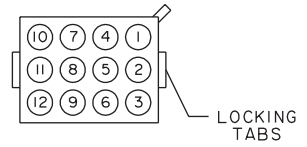

HOUSING - CONNECTOR (J3) WIRING END

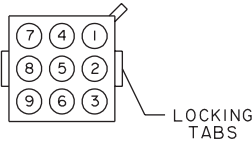

HOUSING - CONNECTOR (J7 & J8) WIRING END

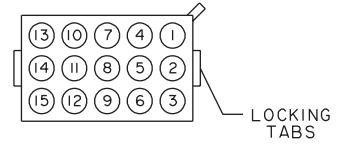

HOUSING - CONNECTOR (J4) WIRING END

PLUG NO.	WIRE NO.	PLUG PIN NO.
P1	21	1
	2	2
	22	3
	31	4
	32	5

PLUG NO.	WIRE NO.	PLUG PIN NO.
P2	21	1
	2	2
	22	3
	33	4
34	5	

PLUG NO.	WIRE NO.	PLUG PIN NO.
P3	2	1
	GRD	2
	129	5
	127	6
	121	11

PLUG NO.	WIRE NO.	PLUG PIN NO.
P4	2	1
	GRD	2
	227	4
	229	5
	221	11

PLUG NO.	WIRE NO.	PLUG PIN NO.
P5	130	1
	131	2
	132	3
	148	4
	118	6

PLUG NO.	WIRE NO.	PLUG PIN NO.
P6	230	1
	231	2
	232	3
	248	4
	218	6

PLUG NO.	WIRE NO.	PLUG PIN NO.
P7	125	1
	2	2
	123	3
	140	4
	141	5
	142	6
	32	7

PLUG NO.	WIRE NO.	PLUG PIN NO.
P8	225	1
	2	2
	223	3
	240	4
	241	5
	242	6
	34	7

PLUG NO.	WIRE NO.	PLUG PIN NO.
J1	21	1
	2	2
	22	3
	3Y	4
	3X	5

PLUG NO.	WIRE NO.	PLUG PIN NO.
J2	21	1
	2	2
	22	3
	3Y	4
	3X	5

PLUG NO.	WIRE NO.	PLUG PIN NO.
J3	2	1
	GRD	2
	125	4
	129	5
	127	6
	121	11
	122	12

PLUG NO.	WIRE NO.	PLUG PIN NO.
J4	2	1
	GRD	2
	225	3
	227	4
	229	5
	221	11
	122	12

PLUG NO.	WIRE NO.	PLUG PIN NO.
J5	30	1
	31	2
	32	3
	48	4
	18	6

PLUG NO.	WIRE NO.	PLUG PIN NO.
J6	30	1
	31	2
	32	3
	48	4
	18	6

PLUG NO.	WIRE NO.	PLUG PIN NO.
J7	25	1
	2	2
	23	3
	40	4
	41	5
	42	6
	3X	7

PLUG NO.	WIRE NO.	PLUG PIN NO.
J8	25	1
	2	2
	23	3
	40	4
	41	5
	42	6
	3X	7







LD03281

NOTES:

1. FIELD WIRING TO BE IN ACCORDANCE WITH THE CURRENT EDITION OF THE NATIONAL ELECTRICAL CODE AS WELL AS ALL OTHER APPLICABLE CODES AND SPECIFICATIONS.
2. CONTACTS MUST BE SUITABLE FOR SWITCHING 24VDC. (GOLD CONTACTS RECOMMENDED). WIRING SHALL NOT BE RUN IN THE SAME CONDUIT WITH ANY LINE VOLTAGE (CLASS 1) WIRING.
3. TO CYCLE UNIT ON AND OFF AUTOMATICALLY WITH CONTACT SHOWN, INSTALL A CYCLING DEVICE IN SERIES WITH THE FLOW SWITCH. SEE NOTE 2 FOR CONTACT RATING AND WIRING SPECIFICATIONS.
4. TO STOP UNIT (EMERGENCY STOP) WITH CONTACTS OTHER THAN THOSE SHOWN, INSTALL THE STOP CONTACT BETWEEN TERMINALS 5 AND 1. IF A STOP DEVICE IS NOT INSTALLED, A JUMPER MUST BE CONNECTED BETWEEN TERMINALS 5 AND 1. DEVICE MUST HAVE A MINIMUM CONTACT RATING OF 6A AT 115VOLTS A.C.
5. CONTACTS ARE RATED AT 115V, 100VA, RESISTIVE LOAD ONLY, AND MUST BE SUPPRESSED AT LOAD BY USER.
6. SEE INSTALLATION, OPERATION AND MAINTENANCE MANUAL WHEN OPTIONAL EQUIPMENT IS USED.

LD03282

LEGEND

- TS TRANSIENT VOLTAGE SUPPRESSION
-  TERMINAL BLOCK FOR CUSTOMER CONNECTIONS
-  TERMINAL BLOCK FOR CUSTOMER LOW VOLTAGE (CLASS 2) CONNECTIONS. SEE NOTE 2.
-  TERMINAL BLOCK FOR YORK CONNECTIONS ONLY
-  WIRING AND COMPONENTS BY YORK
-  OPTIONAL EQUIPMENT
-  WIRING AND/OR COMPONENTS BY OTHERS

LD03283

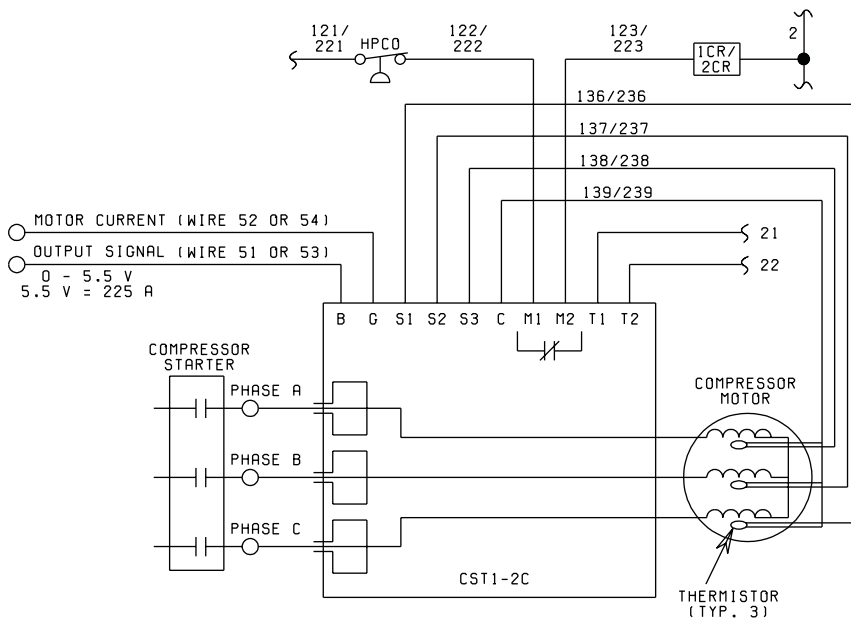

DETAIL "A"

LD03284

CONNECTION DIAGRAM (SYSTEM WIRING)

CONNECTION DIAGRAM SYSTEM WIRING
 YCAS 160-230
 YCAS 453-653
 (STYLE F)

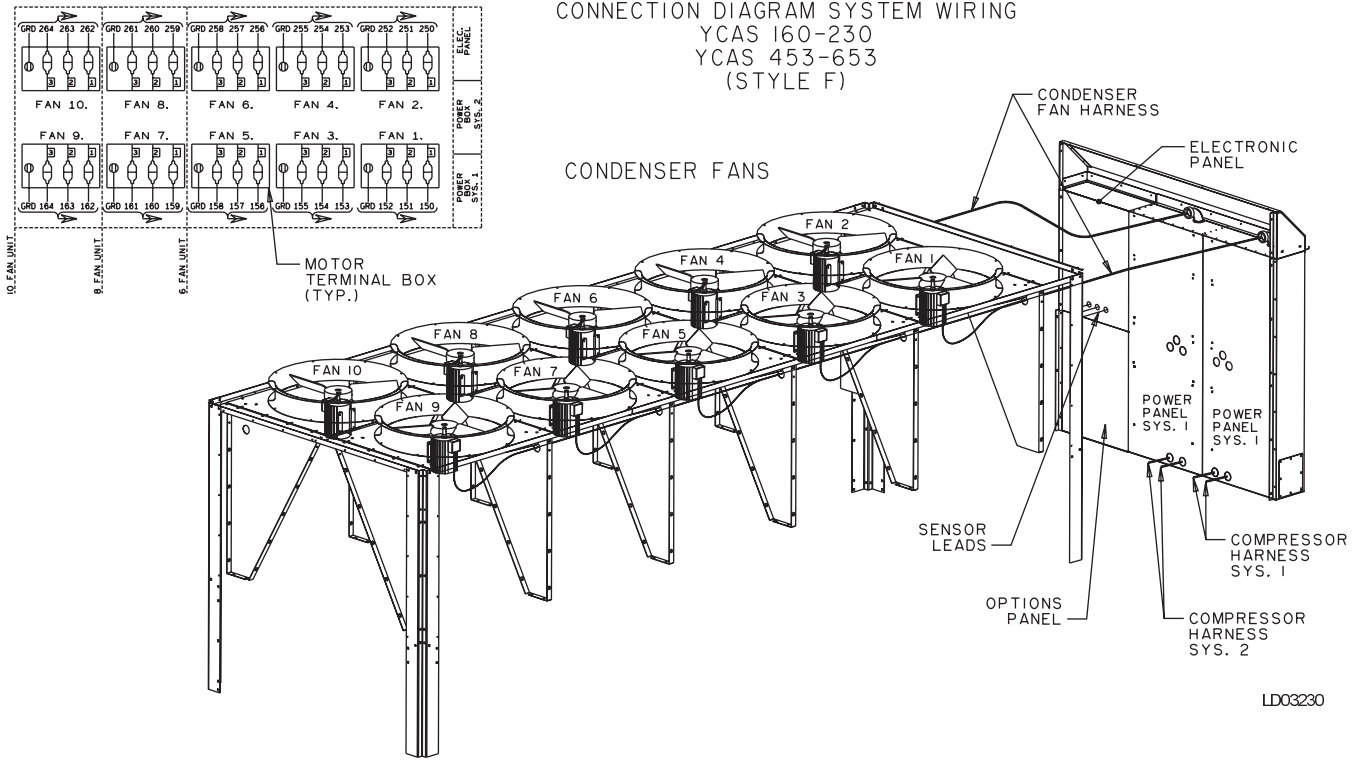

LEGEND

- 1 HPCO SYS. No.1 HIGH PRESS. CUTOUT
- 2 HPCO SYS. No.2 HIGH PRESS. CUTOUT
- 1 HTR SYS. No.1 COMPR. CRANKCASE HEATER
- 2 HTR SYS. No.2 COMPR. CRANKCASE HEATER
- 3 HTR COOLER HEATER
- 1 LLSV SYS. No.1 LIQUID LINE SOLENOID VALVE (UNIT IDENT)
- 2 LLSV SYS. No.2 LIQUID LINE SOLENOID VALVE (UNIT IDENT)
- 1 ESV ECONOMIZER SOLENOID VALVE (UNIT IDENT)
- 2 ESV ECONOMIZER SOLENOID VALVE (UNIT IDENT)
- TXV 1 SYS. No.1 THERMAL EXPANSION VALVE (UNIT IDENT)
- TXV 2 SYS. No.2 THERMAL EXPANSION VALVE (UNIT IDENT)

COOLER

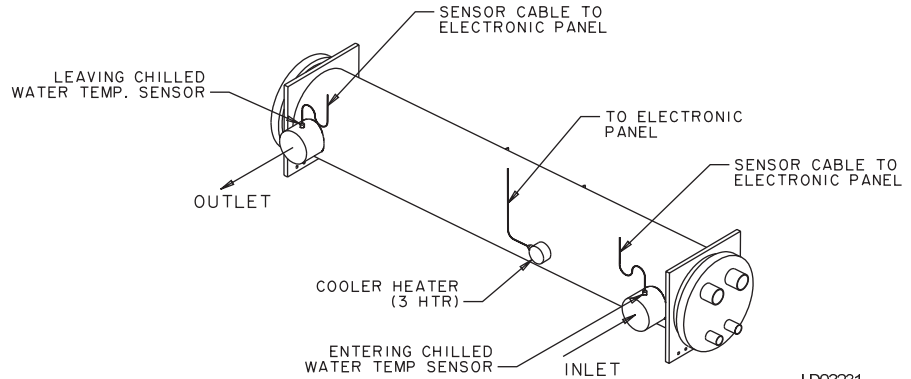

COMPRESSORS (SYSTEMS 1 & 2)

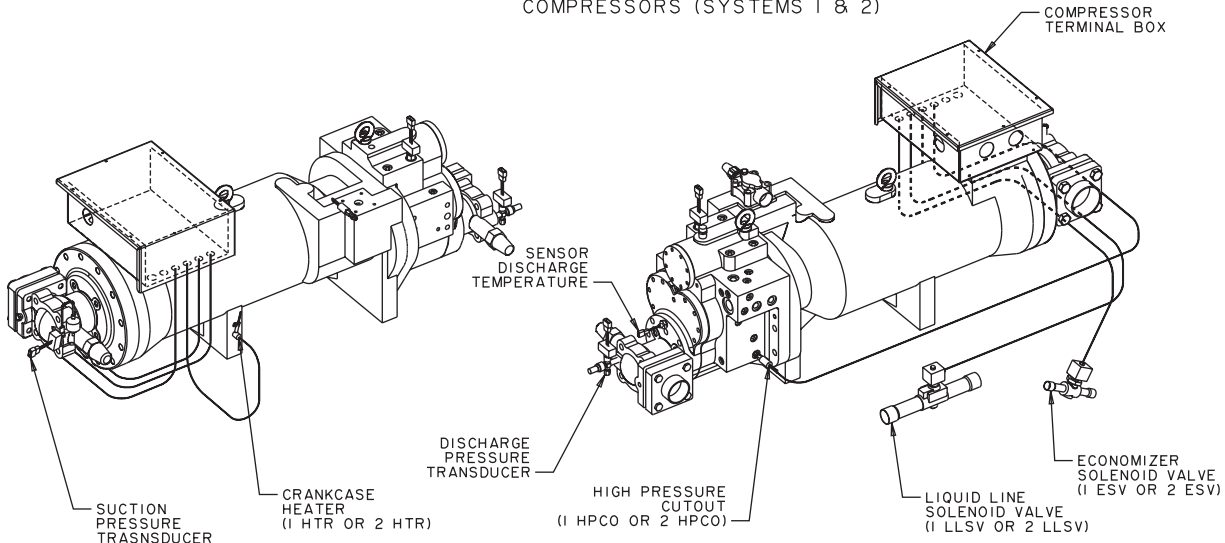

COMPRESSOR TERMINAL BOX

SYSTEM 1 & 2 WYE-DELTA-START
2 & 4 POWER HARNESS UNITS

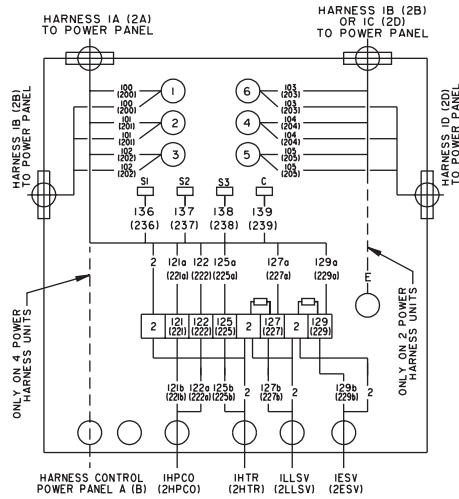

SYSTEM 1 & 2 ACROSS THE LINE
1 POWER HARNESS UNITS

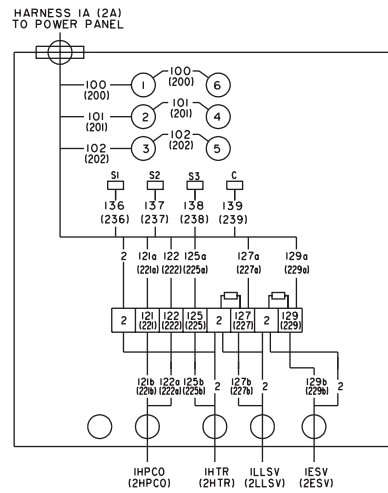

SYSTEM 1 & 2 ACROSS THE LINE
2 POWER HARNESS UNITS

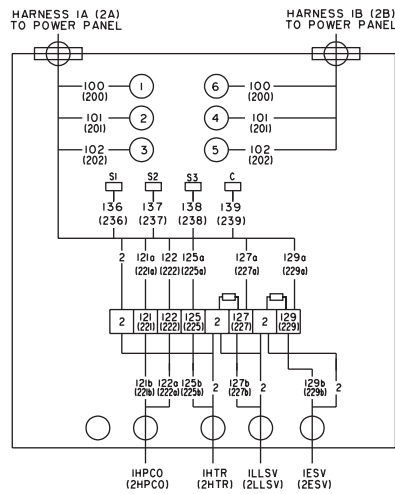

SYSTEM 1 & 2 ACROSS THE LINE
4 POWER HARNESS UNITS

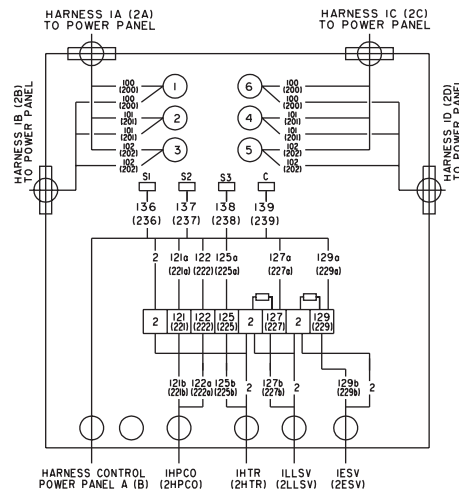

LD03233

MULTI-POINT POWER SUPPLY WIRING – STANDARD UNIT

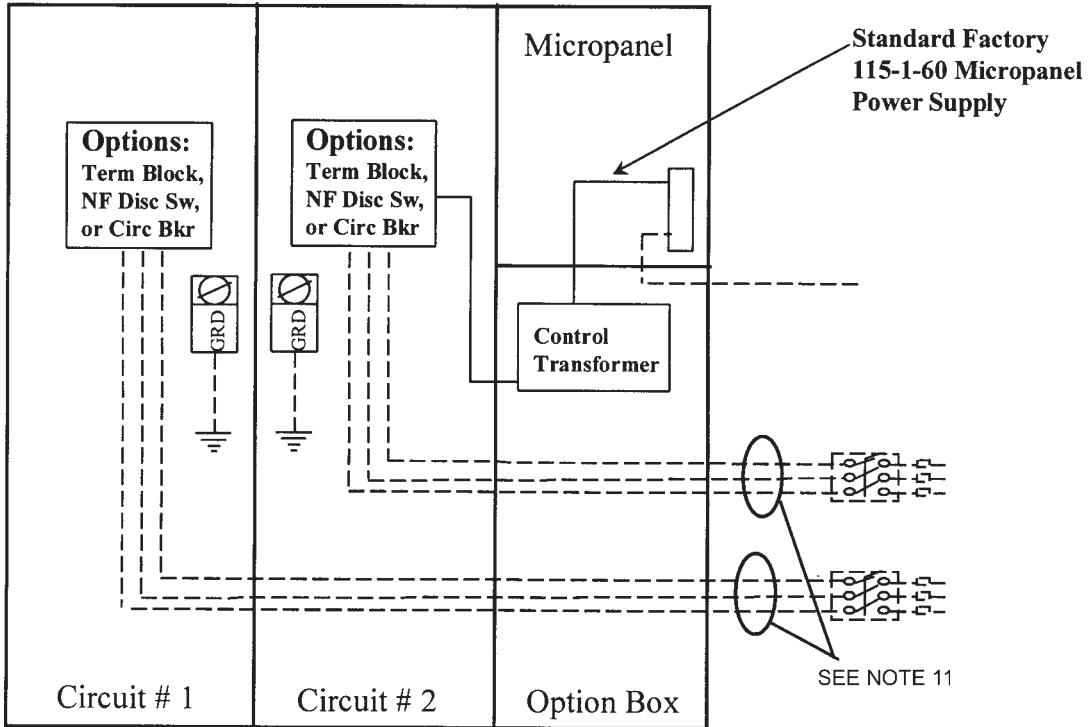

LD03254

SINGLE POINT POWER SUPPLY – WIRING WITH CIRCUIT BREAKERS

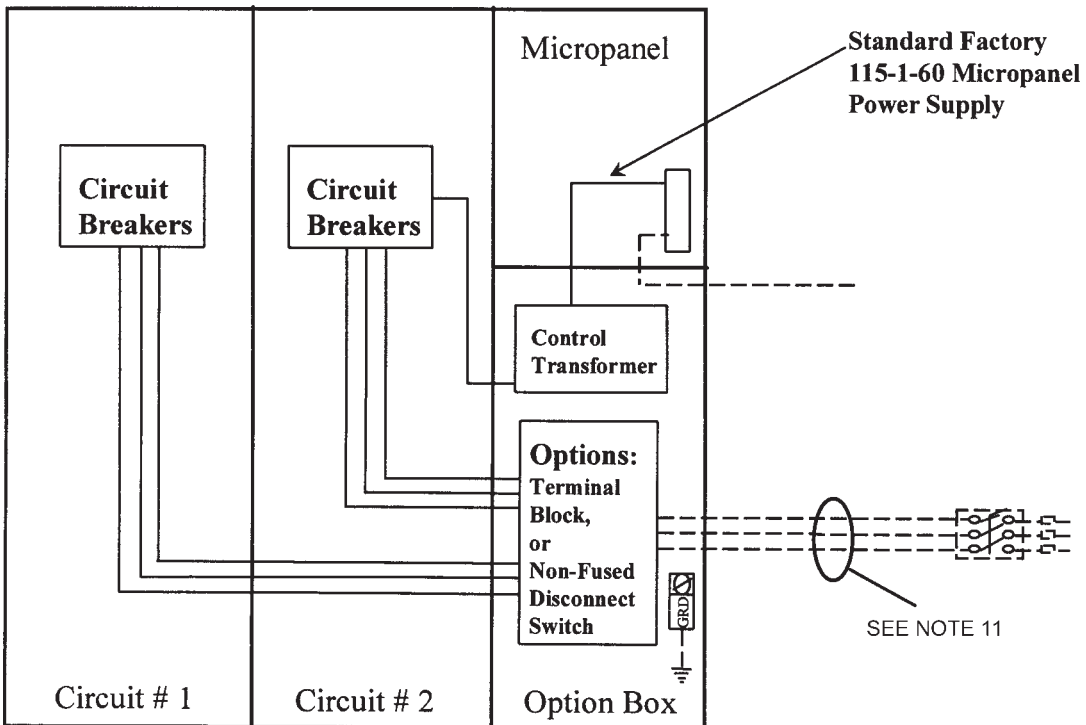

LD03255

SINGLE POINT POWER WIRING WITH FIELD SUPPLIED CIRCUIT PROTECTION

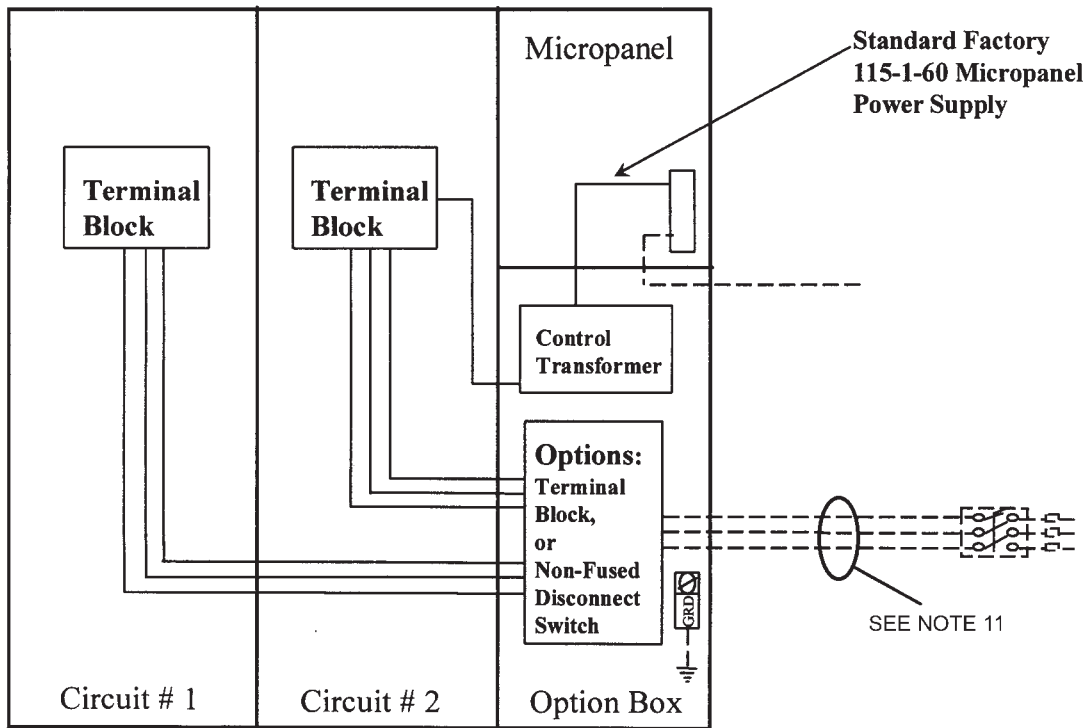

SINGLE POINT POWER WIRING WITH CIRCUIT BREAKERS

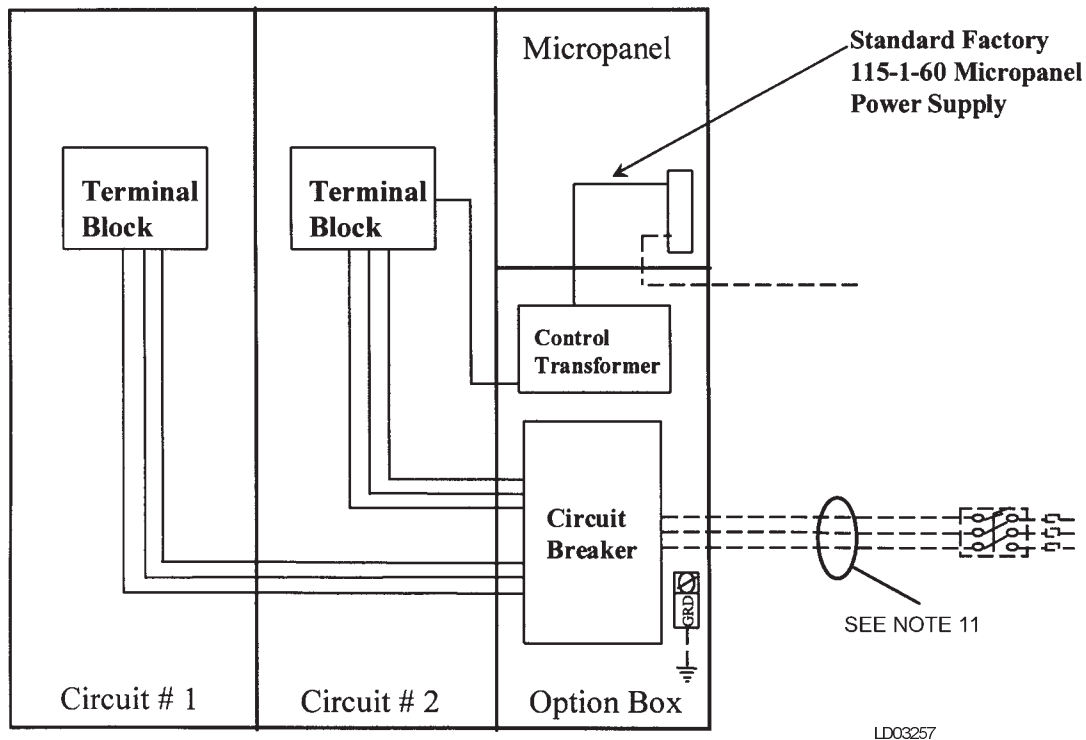

ELECTRICAL POWER WIRING – OPTIONS: TERMINAL BLOCKS

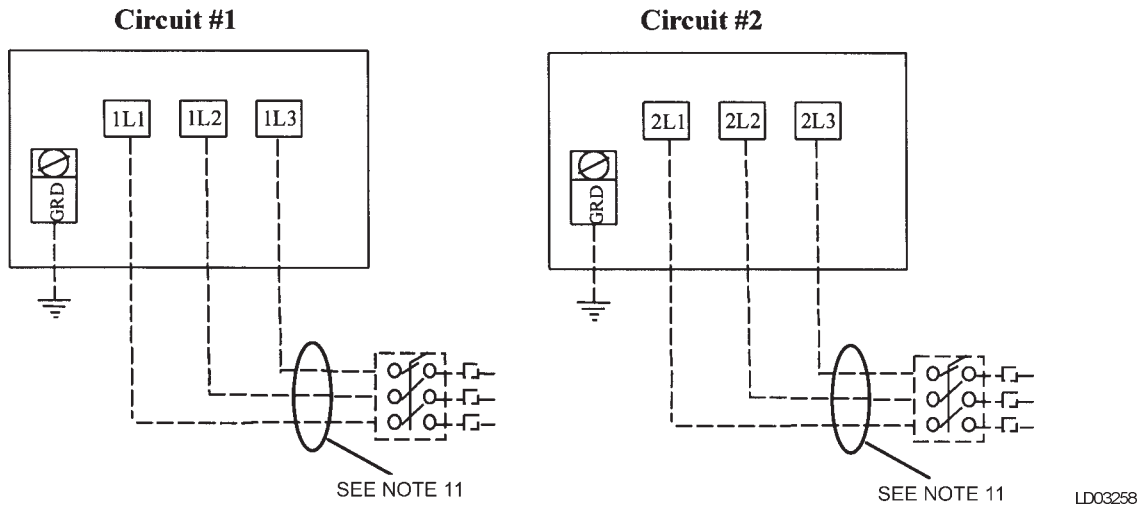

ELECTRICAL POWER WIRING – OPTIONS: NON FUSED DISCONNECT SWITCH

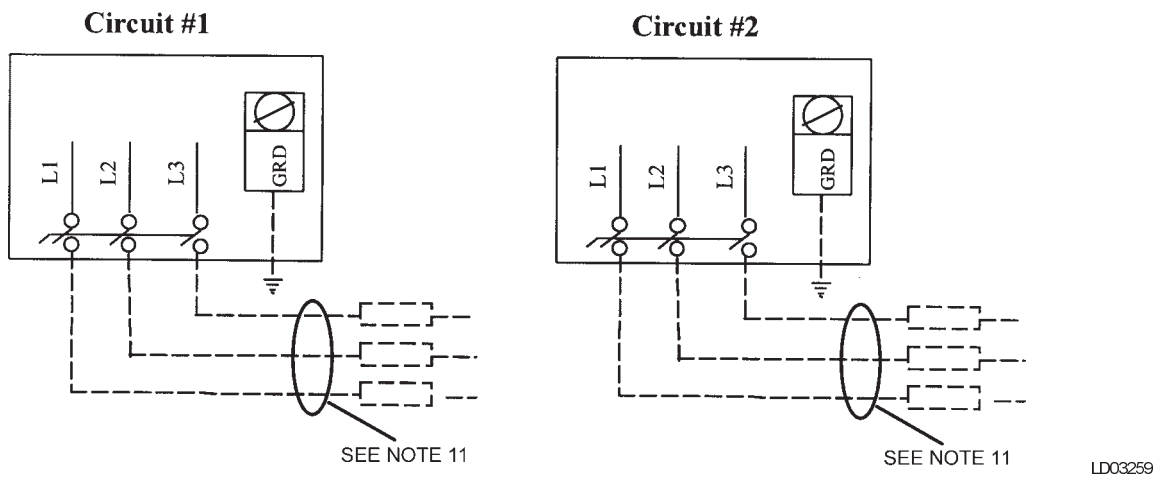

ELECTRICAL POWER WIRING – OPTIONS: TERMINAL BLOCKS

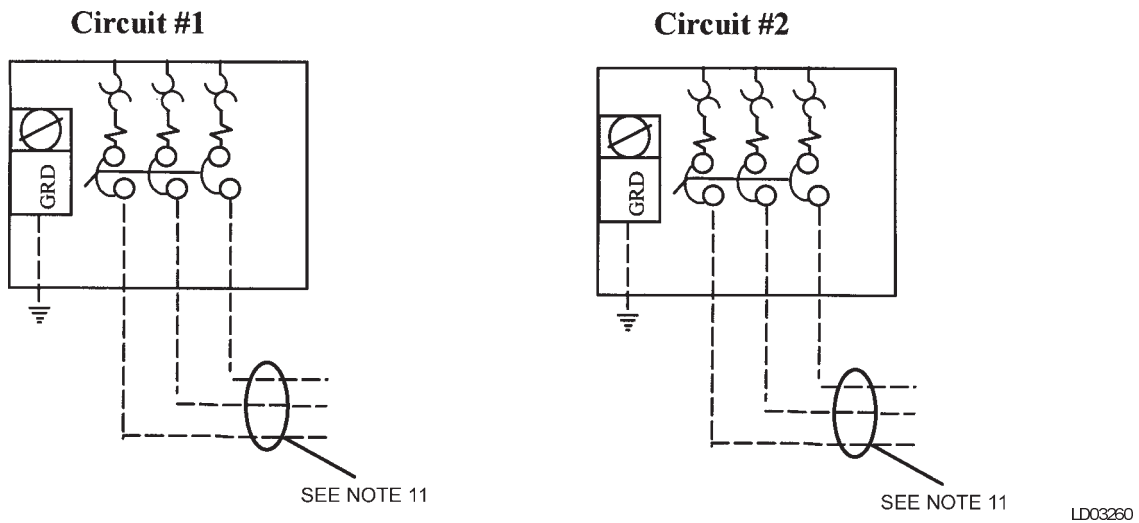

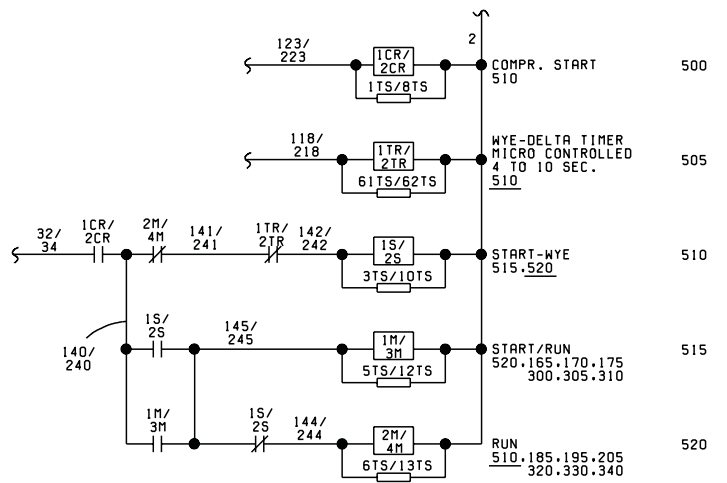
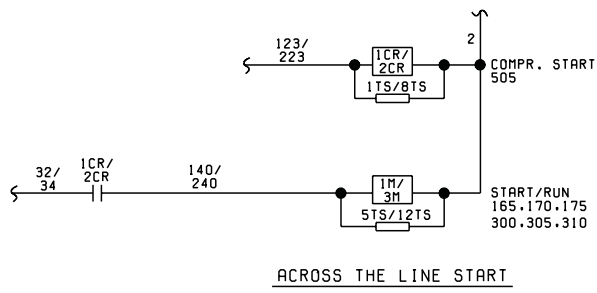

DETAIL "B"

WYE DELTA START

LD03286

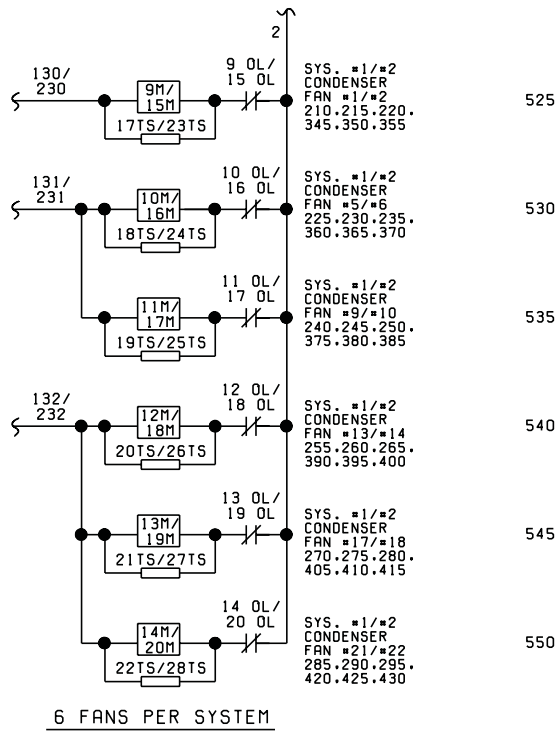
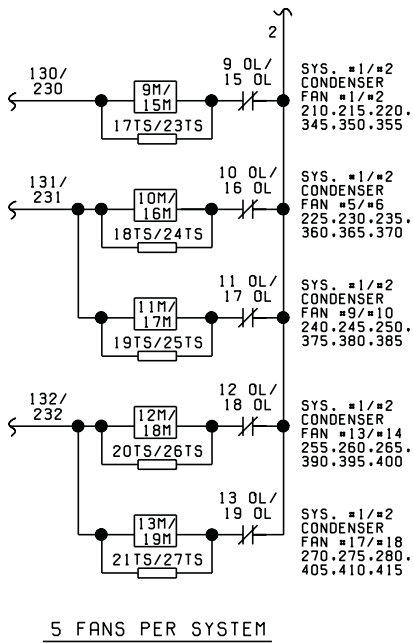
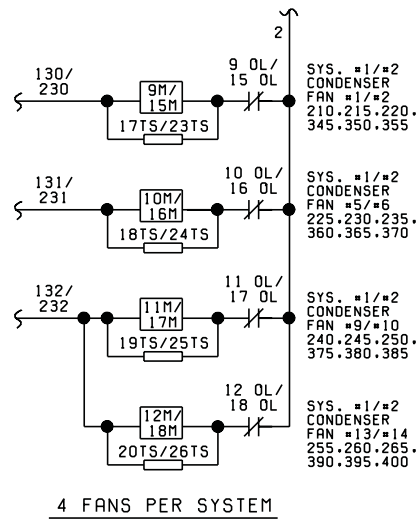
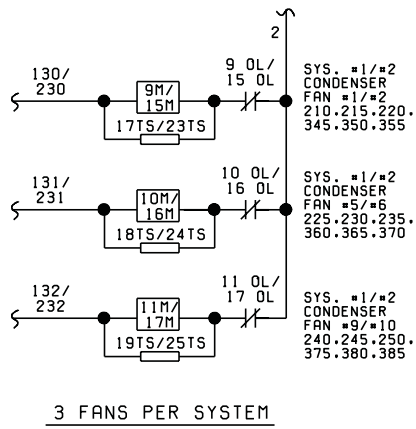

DETAIL "C"

SEE ENGINEERING GUIDE OR INSTALLATION, OPERATION AND MAINTENANCE MANUAL FOR NUMBER OF CONDENSER FANS FOR CHILLER MODEL.

LDC3286



Proud Sponsor of the 1998 U.S. Olympic Team

36JSC380