



# ESG Service Information

File In/With: N/A

SI0040  
New 11-02

Equipment YCAS/YCWS Chillers  
Affected:

Methods to Diagnose DXS Compressor Unloading Problems

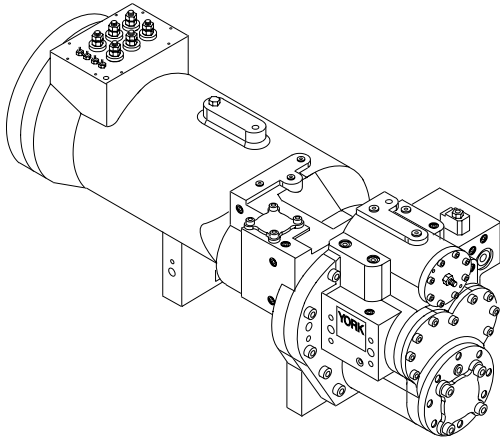

## General

To determine if the compressor is loading/unloading correctly, use one of the following procedures, depending on the system operating conditions.

## Run Compressor to Full 75 Steps

### AMPERAGE METHOD #1 (See photos at right)

1. Run the compressor to a full 75 steps.
2. Measured voltage  $\cong$  10-12 VDC to slide valve.



*Micropanel % fully loaded amps (FLA) will typically be  $\cong$  70-85% FLA on the display.*

## Remove Power to the Capacity Control Solenoid Valve

3. Unplug wiring (remove power) to the capacity control solenoid valve.
4. If unloading has occurred, % FLA current will decrease:
  - a. Air Cooled Chillers  $\approx$  25-35% decrease
  - b. Water Cooled Chillers  $\approx$  20% decrease



*Micropanel % FLA unloaded currents will be  $\cong$  45-60% FLA on the display.*

5. If the current does not change sufficiently from unloaded to fully loaded, change the capacity control valve as detailed in this letter.

## Determine Decrease in Loaded to Unloaded % FLA

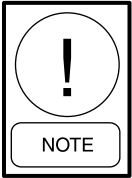
**AMPERAGE METHOD #2** (See photo below)

*This method should be used if the load is low and the chiller pulls down temperature before the compressor loads up under control of the micro.*

1. Remove the signal wiring to the slide valve of the specific compressor at the I/O expansion board.
2. Connect the (-) signal wire to 12v return of the power supply board. Connect the (+) signal wire to +12v of the power supply board.

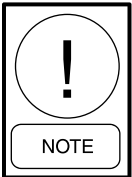

*Care must be taken to assure clip leads/wires do not short together or to other circuitry.*

3. Check the voltage to assure there is at least 10 vdc to the slide valve.

*Micropanel % fully loaded amps (FLA) will be  $\cong$  70-85% FLA, on the display.*

4. Unplug wiring (remove power) to the capacity control solenoid valve.
5. If unloading has occurred, % FLA current will decrease:
  - a. Air Cooled Chillers  $\approx$  25-35% decrease
  - b. Water Cooled Chillers  $\approx$  20% decrease

*Micropanel % FLA unloaded current will be  $\cong$  45-60% FLA on the display.*

6. If the current does not change sufficiently from unloaded to fully loaded, change the capacity control valve as detailed in this letter.



**Determine Decrease in % FLA  
Loaded to Unloaded**

## CHANGING THE CAPACITY CONTROL SOLENOID VALVE

1. Pump down the compressor and close off all valves.
2. Recover the remaining refrigerant in the compressor.
3. Unplug wiring (remove power) to solenoid.



**Check Torques**

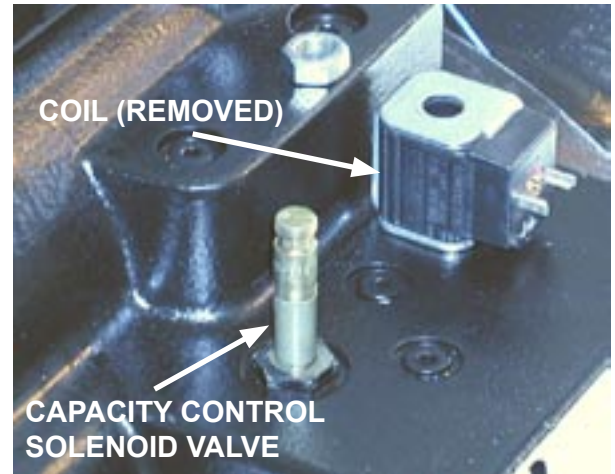

**Change Solenoid. Apply Specified Torques When Replacing**

4. Check solenoid torque when removing
  - a. Valve **body**: NOT to EXCEED **10** ft. lbs.
  - b. Valve **coil**: NOT to EXCEED **3** ft. lbs.

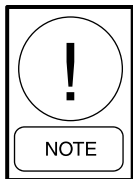

*Exceeding the specified torque will result in solenoid valve malfunction.*

5. Remove the old valve.
6. Install the new valve, coil and nut. DO NOT torque the valve beyond 10 ft./lbs. DO NOT torque the coil nut beyond 3 ft./lbs.
7. Evacuate the compressor to 500 microns
8. Return the compressor to service.
9. If loading and unloading problems exist after the valve change, continue to the following steps and refer to the photos on page 4.

## COMPRESSOR DOESN'T LOAD/UNLOAD AFTER CHANGING CAPACITY CONTROL SOLENOID VALVE

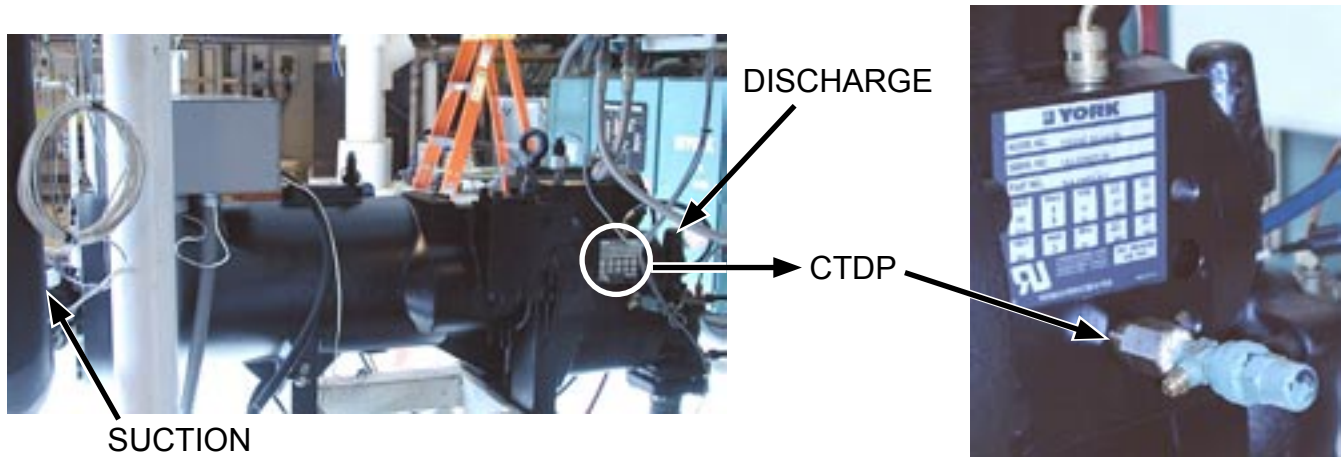

10. Check “Closed Thread Drain Port” (CTDP) pressure located below the name plate/discharge side of the compressor while the compressor is running and compare to the suction pressure measured with a gauge. This port is sealed with a 7/16” O-ring plug and is located directly under the nameplate. Install a 7/16” x 20 UNF x 1/4 NPT coupling (023-18092-000).

- a.  $\text{CALCULATED PRESSURE} = 1.2 \times \text{suction pressure (PSIG)}$ .

If the pressure measured (CTDP) at the port IS GREATER THAN CALCULATED PRESSURE, replace the compressor and return the defective compressor to YORK, Roanoke at:

YORK International  
479 East Park Drive  
Roanoke, VA 24019

A return material authorization number (RMA) may be obtained by calling the Roanoke plant direct at 540-977-4419, extension 221.

*Complete this check sheet. If a defect is found, fax the check sheet to (717)-771-6844. If the compressor needs to be replaced, return a second copy of the check sheet with the compressor.*

Chiller Model \_\_\_\_\_ Chiller System # \_\_\_\_\_

Chiller Serial # \_\_\_\_\_ Compressor Model/Serial # \_\_\_\_\_

CHECK SHEET	
FAULT STEPS	READINGS
Chiller % FLA At 75 Steps, or + 12 VDC on the Solenoid	% FLA
Chiller % FLA with Capacity Control Solenoid Disconnected	% FLA
Record Actual Torque of Capacity Control Valve, When Removed	Ft./Lbs
Indicate If Replacement Capacity Control Valve Fitted	<input type="checkbox"/> Yes <input type="checkbox"/> No
Indicate If Replacement Capacity Control Valve Cured Unloading Problems	<input type="checkbox"/> Yes <input type="checkbox"/> No
If Capacity Control Valve Did Not Solve the Problem, Complete the Following	
Check Closed Thread Port Pressure (CTDP)	PSIG
Calculated Pressure = 1.2 x Suction Pressure	PSIG
Is CTDP Pressure Greater Than the Calculated Pressure?	<input type="checkbox"/> Yes <input type="checkbox"/> No

Comments: