



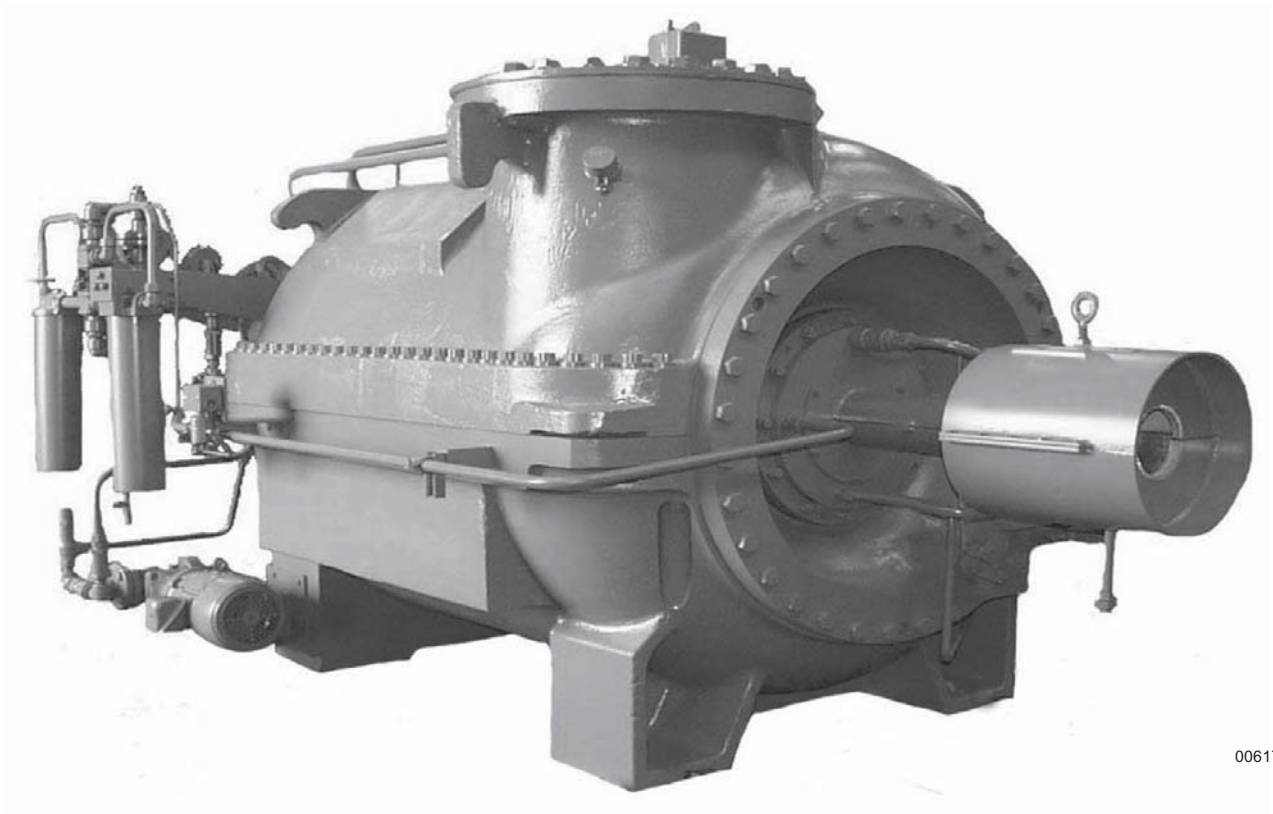
## SERIES M TURBOMASTER COMPRESSORS

INSTALLATION, OPERATION AND  
MAINTENANCE

Supersedes: 220.11-NM1 (366)

Form 220.11-NM2 (602)

## SERIES M TURBOMASTER COMPRESSORS



00617VIP

# IMPORTANT!

## READ BEFORE PROCEEDING!

### GENERAL SAFETY GUIDELINES

This equipment is a relatively complicated apparatus. During installation, operation, maintenance or service, individuals may be exposed to certain components or conditions including, but not limited to: refrigerants, oils, materials under pressure, rotating components, and both high and low voltage. Each of these items has the potential, if misused or handled improperly, to cause bodily injury or death. It is the obligation and responsibility of operating/service personnel to identify and recognize these inherent hazards, protect themselves, and proceed safely in completing their tasks. Failure to comply with any of these requirements could result in serious damage to the equipment and the property

in which it is situated, as well as severe personal injury or death to themselves and people at the site.

This document is intended for use by owner-authorized operating/service personnel. It is expected that this individual possesses independent training that will enable them to perform their assigned tasks properly and safely. It is essential that, prior to performing any task on this equipment, this individual shall have read and understood this document and any referenced materials. This individual shall also be familiar with and comply with all applicable governmental standards and regulations pertaining to the task in question.

---

## SAFETY SYMBOLS

The following symbols are used in this document to alert the reader to areas of potential hazard:



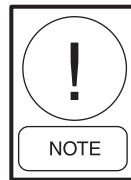
***DANGER*** indicates an imminently hazardous situation which, if not avoided, will result in death or serious injury.



***CAUTION*** identifies a hazard which could lead to damage to the machine, damage to other equipment and/or environmental pollution. Usually an instruction will be given, together with a brief explanation.



***WARNING*** indicates a potentially hazardous situation which, if not avoided, could result in death or serious injury.



***NOTE*** is used to highlight additional information which may be helpful to you.



***External wiring, unless specified as an optional connection in the manufacturer's product line, is NOT to be connected inside the panel cabinet. Devices such as relays, switches, transducers and controls may NOT be installed inside the panel. NO external wiring is allowed to be run through the panel. All wiring must be in accordance with YORK's published specifications and must be performed ONLY by qualified YORK personnel. YORK will not be responsible for damages/problems resulting from improper connections to the controls or application of improper control signals. Failure to follow this will void the manufacturer's warranty and cause serious damage to property or injury to persons.***

## CHANGEABILITY OF THIS DOCUMENT

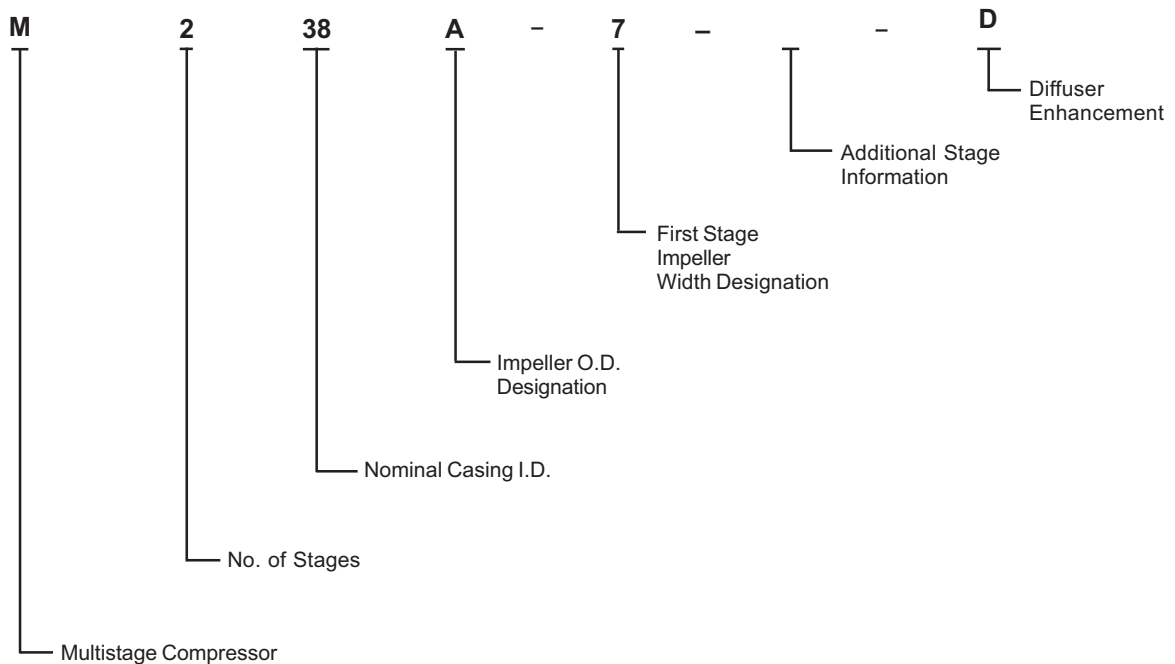
In complying with YORK's policy for continuous product improvement, the information contained in this document is subject to change without notice. While YORK makes no commitment to update or provide current information automatically to the manual owner, that information, if applicable, can be obtained by contacting the nearest YORK Engineered Systems Group office.

It is the responsibility of operating/service personnel as to the applicability of these documents to the equipment in question. If there is any question in the mind of operating/service personnel as to the applicability of these documents, then, prior to working on the equipment, they should verify with the owner whether the equipment has been modified and if current literature is available.

## REFERENCE INSTRUCTIONS

DESCRIPTION	FORM NO.
CONCRETE BASES	160.71-N1.1
INSTALLATION – OM SYSTEMS	160.71-N1
EFFECTS OF MOISTURE IN REFRIGERANT SYSTEMS	55.60-NM10
VACUUM DEHYDRATION	55.60-NM12
CENTRIFUGAL COMPRESSOR COUPLING ALIGNMENT	160.71-N2

## NOMENCLATURE



# TABLE OF CONTENTS

**SECTION 1** Description of System and Fundamentals of Operation ..... 7

**SECTION 2** Installation ..... 11

**SECTION 3** Operation ..... 14

**SECTION 4** Service ..... 32

## LIST OF TABLES

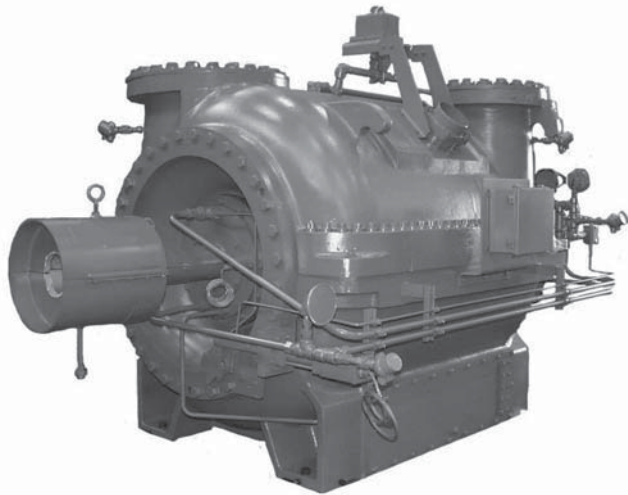
<b>TABLE</b>		<b>PAGE</b>
1	Casing Sizes .....	7
2	Approximate Housing Weights For Series M Compressors .....	13
3	Approximate Component Weights For Series M Compressors .....	13
4	Major Compressor Parts .....	19
5	AOP Differential Control Settings .....	29
6	COP Low Oil Differential Safety Settings .....	29
7	Oil Pressure Switch Tubing Sizing .....	30
8	Maintenance Requirements for YORK Multistage Centrifugal Compressors .....	33
9	Compressor Tools .....	37
10	Shaft Seal Parts .....	39
11	Typical Shaft Seal Installation "Height" Dimension .....	40
12	Clearances .....	46
13	Screw Sizes for Pulling Drive End Journal Bearing .....	46
14	General Bolt Torques .....	47

## LIST OF FIGURES

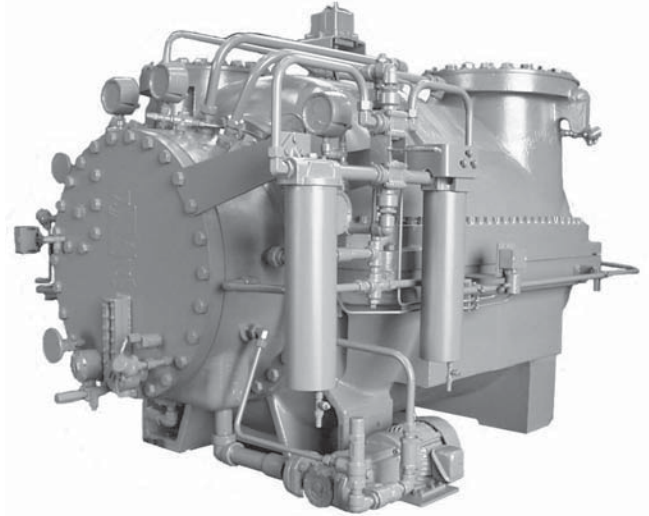
<b>FIGURE</b>		<b>PAGE</b>
1	Model Series M Turbomaster Compressor .....	7
2	Typical Compressor Cross-Sectional View .....	9
3	Typical Primary Compressor Gas Flow .....	15
4A	Balance Piston .....	17
4B	Cut-A-Way View - Model 255 Compressor .....	17a
5	External Sump Vent Equalizing Lines .....	19
6	Exploded View of Atmospheric Shaft Seal .....	20
7	Oil Piping Schematic, Applicable for Models Prior to 1970 .....	22
8	Oil Piping Schematic, Applicable for Models After 1970 .....	23
9	Compressor Tools .....	37
10	Coupling Guard .....	37
11	Coupling Wrench Application .....	37
12	Loosening the Drive Shaft with Special Wrenches .....	38
13	Loosening Drive Shaft with Wrenches .....	38
14	Shaft Seal Parts .....	39
15	Assembling Shaft Seal Collar .....	40
16	Seal Ring Assembly .....	40
17	Removing Drive End Journal Bearing Assembly .....	42
18	Removing Drive End Oil Seal Assembly .....	42
19	Exploded View PRV and Oil Seal Assembly .....	43
20	Oil Reservoir .....	47
21	Discharge End Bearing and Oil Pump Assembly, Exploded View .....	48
22	Checking Alignment of Oil Pump .....	49
23	Removing the Oil Reservoir .....	50
24	Exploded View, Oil Reservoir and Oil Seal Assembly .....	51
25	Exploded View, Balance Piston Seal Assembly .....	52
26	Removing the Pre-Rotation Vane Assembly .....	53
27	PRV Housing Assembly (Open and Closed Vanes) .....	53
28	Vane Clamping Fixture .....	54
29	Lifting Top Half of Compressor Casing .....	56
30	After Lifting Top Half of Compressor Casing with Sump Housing Removed .....	56
31	Removing Interstage Labyrinth Seals .....	57
32	Diffusers Removed .....	58
33	Exit Plate Removal .....	58
34	Removing First Stage Impeller Labyrinth Seal .....	59
35	Rotor .....	59

## SECTION 1

### DESCRIPTION OF SYSTEM AND FUNDAMENTALS OF OPERATION



00618VIP



00619VIP

**FIG. 1 – SERIES M TURBOMASTER COMPRESSOR**

#### GENERAL DESCRIPTION

YORK's Series M Turbomaster Compressors are designed for compressing various refrigerants, oil field hydrocarbon gases, CO<sub>2</sub>, air and chemical vapors. They are manufactured in three nominal sizes measured at the inside diameter of the casing. The sizes are 26, 38, and 55 inches. In addition, a 26 inch casing with a small diameter high speed rotor is identified as a 25 inch compressor.

**TABLE 1 – CASING SIZES**

CASINGS SIZES I.D.		25"	26"	38"	55"
WHEEL DIAMETERS (INCHES)	B	8.25	12.2	18.0	26.7
	A	10.0	14.8	21.9	31.5

They consist of two major parts groups, the rotor and the casing. The rotor assembly includes the main shaft, impellers, and shaft driven oil pump. The casing in-

cludes the pressure containing parts and stationary seals. These compressors can incorporate 1 to 8 stages of compression within a single casing. Series M Turbomaster compressors may be directly driven by a turbine, motor, engine, or through a speed increaser/reducer. Rotation must always be driven counter clockwise facing the shaft end.

#### FUNDAMENTALS OF OPERATION AND MACHINE COMPOSITION

This family of compressors has great flexibility in application and the materials of construction will vary based upon the design operating requirements for which it was selected. Casing material can be cast iron, nodular iron or cast steel depending upon the design operation requirements. See Figure 2 for a typical compressor cross-sectional view. Impeller materials can be aluminum or stainless steel, or a combination of both to meet the requirements.

The internal stationary seals can be supplied in aluminum, bronze, or coated cast iron depending on the application. The impeller diameter(s), blade width, and position on the rotor can be varied to permit the introduction of side load connection(s) if required. There can be side load flows into several different stages and they can enter into the bottom or top half of the compressor casing as needed to accommodate the application.

### Bearings

The compressor is equipped with aluminum sleeve taper-bore or taper-land journal bearings, with the size of the suction end bearing being varied as a function of shaft horsepower. The thrust bearing system can incorporate hydrostatic bearings in the active (shaft movement toward coupling) and reverse directions, tilting pad in the active with hydrostatic in the reverse direction, or tilting pad in both active and reverse directions.

### Temperature Sensors and Proximity Probes

The compressor may be equipped with bearing temperature sensors and/or proximity probes for purposes of monitoring compressor shaft vibration and/or axial thrust position.

### Seals

The compressor is equipped internally with gas/oil seals over wind-back spirals on the shaft to control oil from entering the compressor casing. There is also an atmospheric shaft seal to minimize leakage of oil and process gas to the outside where the shaft passes through the housing. Some leakage from this seal is normal with the rate being dependent on shaft speed, coupling diameter, and pressure differential across the seal. There is a provision for that fluid to be directed to an atmospheric drain trap cast into the leg of the main casing.

### Bolt Patterns

Due to the varied application of this compressor family, there can be differences in the bolting and the patterns of the bolting. There will be more bolts utilized in the external patterns when the compressor is designed for a higher design working pressure. There can be variations on the internal bolting strength and sizing if

the application requires resistance to the effects of certain corrosion phenomenon. The application drawings will indicate these special circumstances with special bolt torque values or notes regarding special identifying features such as “redrawn screws will have green bolt heads.”

### As Built Drawings

It is difficult to define the parameters of a standard multistage compressor although the typical two stage compressor applied on a water chilling / air conditioning duty is the most common type.



***It is imperative to have the “as built” drawings for the specific compressor on hand before ordering spare parts or attempting to work inside the compressor. Failure to do so could result in damage to the machine.***

### SAFETY

It is recommended that all maintenance and service repair work be performed by experienced personnel. There must be recognition of the potential hazards that can exist. Those hazards may include (but are not limited to);

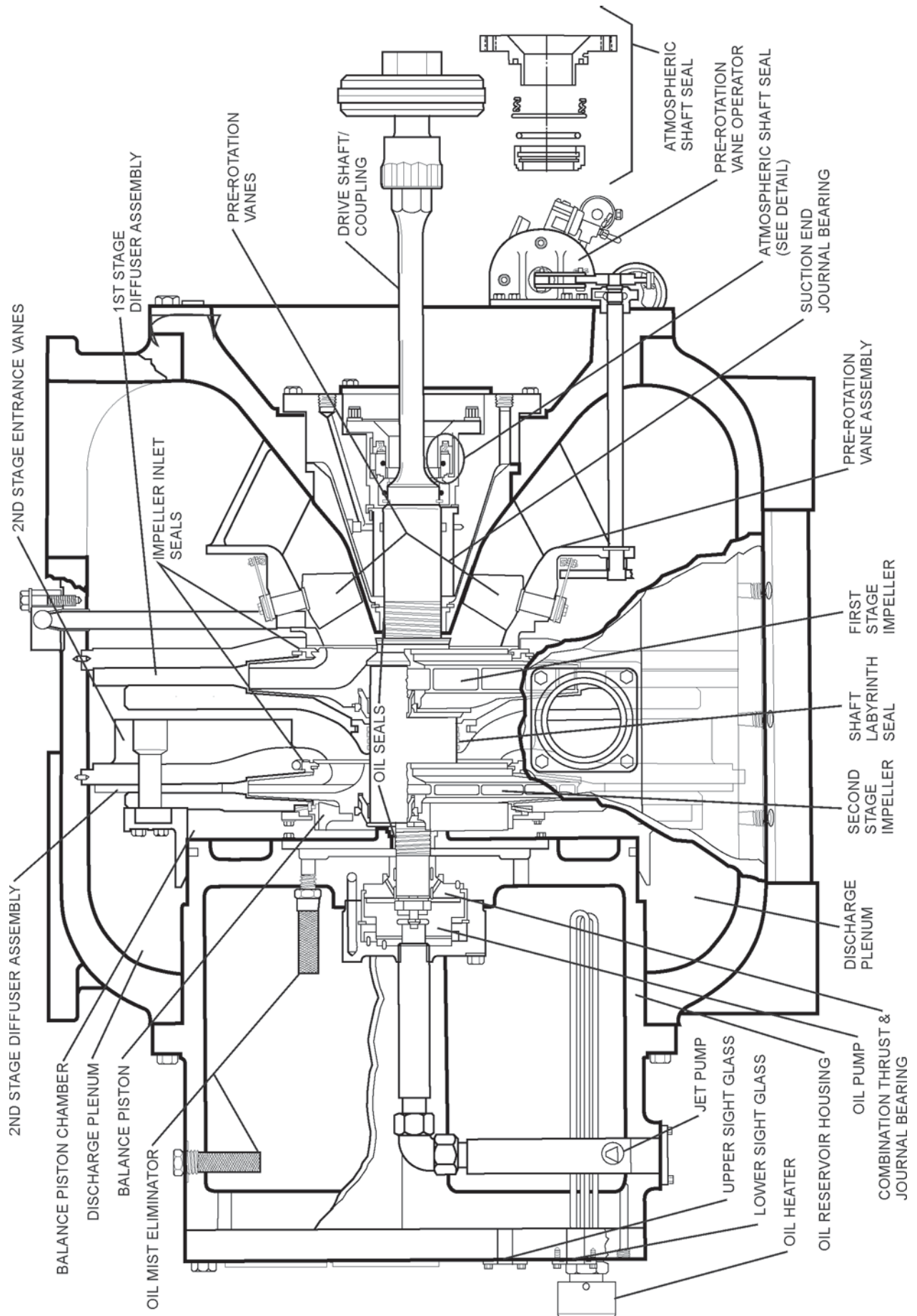


***There can be electrical circuitry that presents an electrocution hazard. Be sure that the source of all power supplies have been properly isolated and secured before attempting any service related activities.***



***The unit must have the coupling guards in place and fully attached at any time the shafts will be rotating. Be sure that the shafts have stopped completely and the main power source has been properly isolated before attempting any service related work activities on the system.***







*The system contains fluids under potentially dangerous pressures, exercise caution when preparing to service or remove parts from the system. Be sure to wear eye protection to avoid any possible splash hazards.*



*There may be surfaces or fluids with temperatures that are hot enough to cause burns or ignite flammable materials. Care must be taken to protect against burns or the ignition of flammables.*



*The compressor contains many close clearance areas and heavy parts which can result in situations where fingers or other extremities may be pinched, crushed, or even severed. Care should be taken when lifting or moving any parts to be sure that any extremities are free from those dangers.*



*The system may contain materials that need to be disposed of in accordance with governing regulations. Please be sure to follow all pertinent requirements when disposing of such materials.*



*Certain liquids that are expelled from the system at atmospheric pressure may be capable of producing a freeze hazard to skin or eyes. Eye protection and gloves should be worn to avoid potential splash hazards.*

## SECTION 2 INSTALLATION

### GENERAL

#### Foundation

These compressors can be furnished with a fabricated steel base for installation on a suitable foundation of sufficient strength and rigidity to support the weight of the operating system. Refer to Figure 2 and Table 3 for housing and component weights.

#### Installation Information

Since the equipment will vary to meet the requirements of a specific installation, it is recommended that the following information be retained for ready reference. These are furnished with each compressor at the time of original purchase:

1. A general arrangement drawing.
2. A sectional assembly drawing.
3. A lubrication system schematic diagram.
4. An oil piping drawing.
5. A coupling instruction.
6. An application data sheet.

#### CONDUCTING THE PRESSURE AND VACUUM / DEHYDRATION TESTS

If a pressure test is required perform the following:



***Perform all pressure testing and evacuations before applying insulation of any kind to the system.***



***Charging of refrigerant should only occur after completion of the evacuation/dehydration procedure. The refrigerant charge should be introduced into the system as outlined in the applicable instructions for the job. Certain conditions can result in very low temperatures which can be damaging to equipment/personnel.***

1. Conduct the pressure test in accordance with design parameters outlined in the application data sheet.

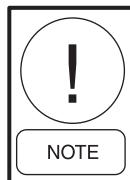


***The compressor's atmospheric shaft seal may leak excessively if the shaft seal reservoir has not been filled with oil.***

2. If the atmospheric shaft seal is leaking, charge the compressor shaft seal reservoir with the appropriate YORK oil (refer to Adding Oil to the Compressor, pages 27 and 28) before continuing the pressure testing.
3. After completion of the pressure testing proceed with the evacuation/dehydration of the system.
4. Conduct the vacuum test in accordance with the procedures outlined in Form 55.60-NM12.

#### INITIAL STARTING – MECHANICAL RUN-IN

Perform the following “bump-in” procedures when starting any compressor for the first time or after replacing bearings and seals.



***Seals may settle and contact the shafts during shipment. A “bump-in” is recommended to position the floating seals in their preferred operating location. Compressors designed for halocarbon refrigerants or air service can be mechanically run-in without exceeding the discharge temperature limit. The application data sheet will set the discharge temperature limit and indicate if a mechanical run-in cannot be performed.***

#### “Bump-in” Procedure for Turbine and Motor Driven Systems



***Shut down the compressor immediately if any abnormal conditions are detected.***



***Exact speeds are difficult to obtain with a motor driven system.***

1. Start the compressor and bring it up to 25% speed and then immediately stop the compressor.
2. After shutting down the compressor, allow the compressor temperatures to stabilize for at least 15 minutes.
3. Repeat steps 1 and 2 at 50% speed, 75% speed, and 100% speed.
4. Operate the compressor at 100% speed for one minute while making the following checks:



***During the initial operating period, checks should be made on all mechanical parts of the system to be sure they are functioning properly. They must include, but are not limited to the following checks:***

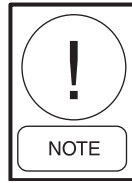
- A. Check for unusual or excessive vibration or overheating.
- B. In addition to compressor, check motor speed increaser / turbine bearing temperatures carefully.



***Compressors that utilize refrigerant cooled oil coolers may not be operated if there is no source of coolant available.***

- C. Check that the oil cooler(s) is functioning properly.
- D. Check the compressor lubrication system (see DAILY OPERATION).
- E. The compressor discharge temperature must not exceed the limits specified in the application data sheet for the application or the safety limits of the controls system.

**Final Coupling Alignment Check  
(Figure 4, Item 16)**



***This procedure is often referred to as the “hot check”.***

1. After at least six hours of operation at design operating conditions, or after the system has stabilized at it’s design operating temperatures, make the complete final coupling alignment check. Refer to the Final Alignment Check as outlined in the coupling instruction Form 160.71-N2.
2. Verify the results of the final coupling alignment check before any effort is made to dowel any of the components, or finalize the adjustments of the base frame jackscrews.

**TABLE 2 – APPROXIMATE HOUSING WEIGHTS FOR SERIES M COMPRESSORS**

CASING ID. (INCHES)	STAGES (LBS.)	TOTAL WEIGHT (LBS.)	CASING (TOP HALF) (LBS.)	ROTOR (LBS.)	
				A	B
25	2 STAGE	4,000	820	31	20
	EA. ADD'L	500	100	10	8
26	2 STAGE	4,000	820	70	60
	EA. ADD'L	500	100	27	22
38	2 STAGE	10,500	2,750	230	190
	EA. ADD'L	1,300	350	90	75
55	2 STAGE	25,000	5,000	630	500
	EA. ADD'L	3,000	1,000	250	200

**TABLE 3 – APPROXIMATE COMPONENT WEIGHTS FOR SERIES M COMPRESSORS**

CASING ID. (INCHES)		GRAY IRON (LBS.)	DUCTILE IRON (LBS.)	STEEL (LBS.)
25/26	PRV HOUSING	350	350	575
	OIL SUMP HOUSING	650	650	810
38	PRV HOUSING	900	900	1,230
	OIL SUMP HOUSING	1,715	1,715	2,165
55	PRV HOUSING	2,125	2,125	2,530
	OIL SUMP HOUSING	3,520	3,520	4,665

## SECTION 3 OPERATION

### GENERAL

The basic operating principles of all centrifugal compressors are the same, regardless of the size or capacity of the compressor or the number of impellers used.

The following paragraphs describe the path of the refrigerant gas flow through a Series M Turbomaster Compressor and the effect upon the gas as it passes from the suction to the discharge connection(s) of the compressor.

### Primary Compressor Gas Flow (Figure 3)

The gas enters the compressor through the suction inlet connection, and passes through the pre-rotation vanes to the inlet throat of the first stage impeller.

The high rotative speed of the impellers causes the suction gas to be drawn into the first stage impeller and is discharged from the blade tips at high velocity and increased temperature and pressure. The discharge space, which is formed by the diffuser and the housing, is shaped to convert some of the velocity energy into pressure rise before directing the gas from the discharge of the first stage impeller into the inlet of the second stage impeller.

From the second stage impeller, the gas passes through the remaining impellers at high velocity and steadily increasing temperature and pressure. The gas is eventually discharged into the annular compressor discharge space, at the oil reservoir end, where it leaves the compressor and enters the discharge line.

A centrifugal compressor does not move a definite quantity of gas under all operating conditions as does a positive displacement compressor. The ability to compress is determined by a performance curve which can be depicted by various parameters, but most frequently head and flow are used.

### Balance Piston (Figure 4)

Since suction gas enters the first stage impeller (1) at suction pressure and leaves the high stage impeller (2) at discharge pressure, the pressure differential becomes progressively greater between the inlet and the discharge of each impeller.

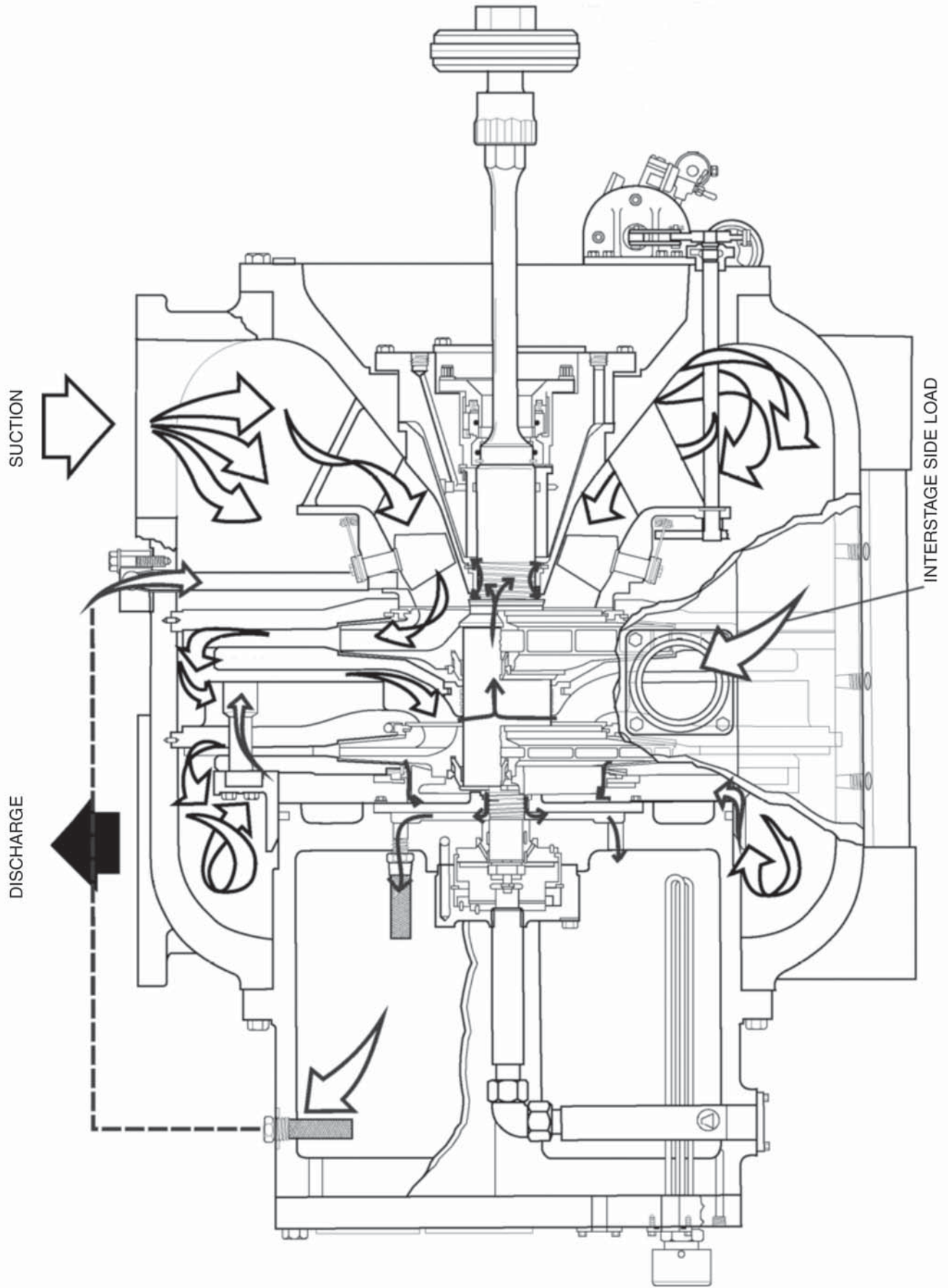
The inlet areas of the impellers are only affected by suction pressure of that stage while the sides of the impeller are subjected to the higher impeller discharge pressure of that stage resulting in a net force pushing toward the impeller inlet.

Because of this pressure difference, an axial thrust force exists which is toward the suction end of the compressor.

To maintain the axial thrust within design limits, a balance piston (3) may be used as a part of the last stage impeller. Gas leakage past the balance piston is regulated by a “floating” seal ring (4).

The balance piston (3) serves as a rotating partition at the end of the discharge gas space. The pressure on the outboard side of this piston is equalized to a lower stage pressure through one or more internal (5) or external gas equalizing lines (See Figure 5, Item 6). The compressor diffuser geometry will determine whether the venting is done internally or externally.

The balance piston (3) is sized so that the pressure differential across it reduces the total axial thrust of the rotor assembly. The balance piston seal (4) is designed to regulate the leakage into the chamber (6). Elevation of the pressure differential across the balance piston above the design will result in increased axial thrust load toward the suction end of the compressor. The thrust bearing (7) serves to physically or mechanically position the shaft (8) and impellers (1 and 2) in the center of the diffuser(s) while the thrust load minimizes the rotor assembly (1, 2 and 3) from shifting axially during surging and load changes. Extreme elevation of the balance piston pressure is an indication of a problem that can result in failure of the thrust bearing (7).



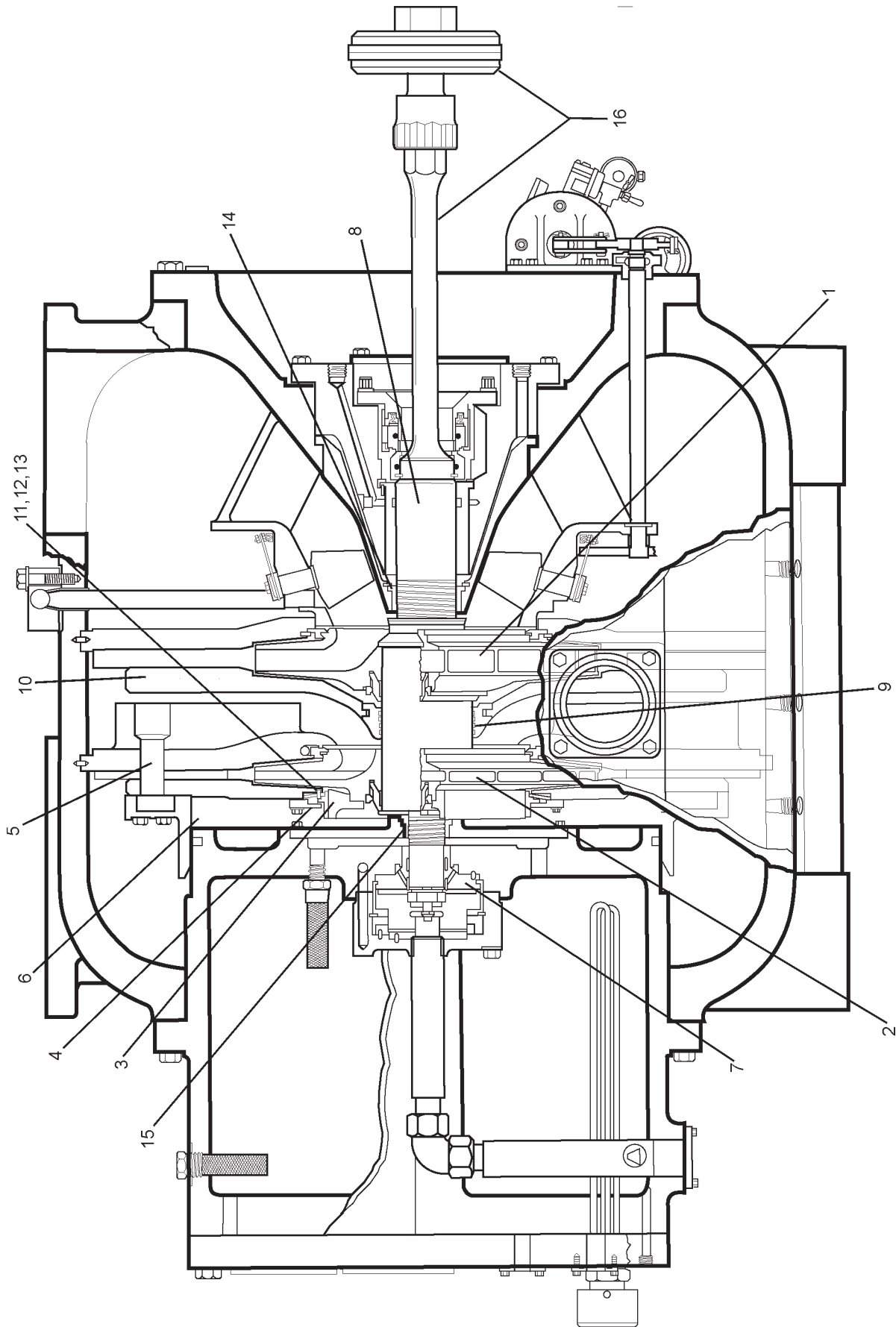
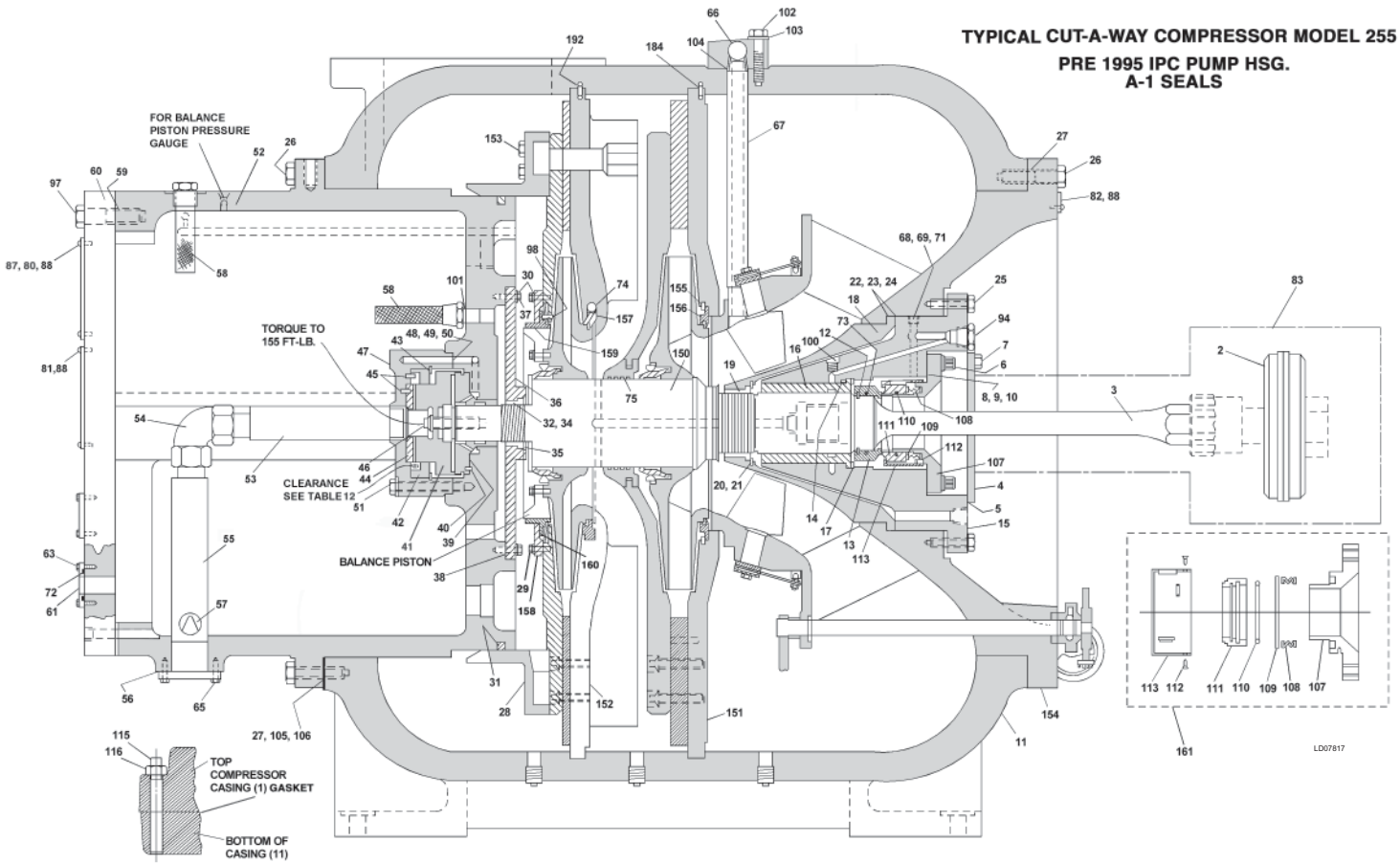


FIG. 4A – MAJOR COMPONENTS



**TYPICAL CUT-A-WAY COMPRESSOR MODEL 255  
PRE 1995 IPC PUMP HSG.  
A-1 SEALS**



3

FIG. 4B - CUT-A-WAY VIEW - MODEL 255 COMPRESSOR  
YORK INTERNATIONAL

**External Sump Vent Equalizing Line (Figure 5)**

Oil that is returning to the reservoir (1) from the bearing drains contains some additional refrigerant gas after passing through the bearings and joining with the buffer gas from the oil seals.

In order to manage that refrigerant gas and the oil reservoir pressure, these compressors are equipped with an external gas line (2) that vents the pressure from the oil reservoir (1) to the inlet (3) of a lower stage impeller or appropriate external source.

There is a screen type mist eliminator installed inside the sump at the inlet (4) of that external gas line (2) to minimize the opportunity for oil to be carried out with the vent flow through the line.

An automatic sump vent valve (5) slows the rate at which the oil reservoir pressure is reduced at start-up. Normally, the valve is field adjusted to open at a rate that will reduce oil reservoir pressure without adversely affecting system oil pressure. Valve adjustment may vary depending on system conditions. The sump vent valve is typically supplied with an orifice through the seat which will prevent total isolation of the vent line. Oil loss through the seals may occur if the compressor is operated for extended periods with the sump vent valve closed.

**Internal Seals**

The internal sealing systems are the backbone of the compressor's efficiency and, in some cases, its reliability. It is very important to perform the following procedures when evaluating the performance of any sealing device.



*The various internal seal systems used in the Series M Turbomaster compressor are assembled with clearances that take into account both thermal effects and inertia growth characteristics of the application. For this reason it is very difficult to tabulate all clearance values for all applications. Form 160.71-M can be used for two-stage water chilling application. The information in that document should not be applied to any other application unless verified on the application data sheet.*

1. Check for proper clearance between all stationary and rotating parts.
2. Inspect the stationary component's seal seating surface. There should not be any burrs, ridges, gouges, etc. where the seal seats in the housing.

**Shaft Labyrinths (Figure 4)**



*The close radial clearance between the shaft labyrinths (9, Figure 4) and the rotor shaft (8) reduces gas leakage to a minimum along the rotor shaft (8).*

Gas leakage between stages is kept to a minimum by means of shaft labyrinths (9) mounted between the (stationary) diffuser exit plates (10) and the rotor shaft (8).

**Balance Piston Seal**



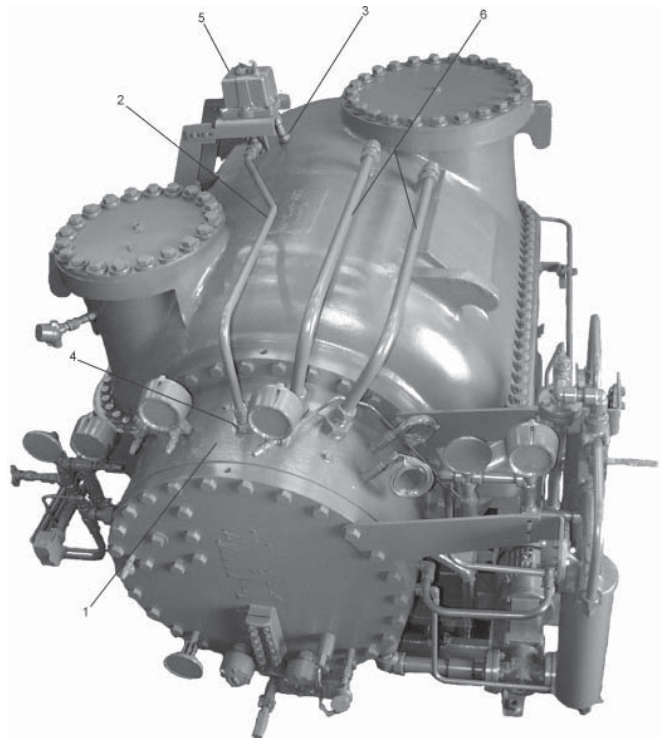
*Leakage from the high stage impeller discharge area around the balance piston diameter is minimized by means of the balance piston seal ring (4, Figure 4).*

The balance piston seal ring system consists of a floating balance piston seal ring (4), spring washer (11), balance piston cover (12) and an anti-rotation pin (13). The anti-rotation pin (13) may prevent the seal ring system from being damaged due to rotation during a surge or system upset condition.

**Oil Seals (Figure 4)**

Oil leakage from the main bearings into the impellers is prevented by means of the oil seals (14, 15) that are located on the rotor shaft inboard from the main bearings.

There are seals that regulate a slight gas leakage (referred to as buffer gas) into the lubrication system at the bearing outlets which opposes and prevents oil leakage. These seals are located over the area of the main shaft that is machined with "wind-back" spirals which are also intended to aid in the prevention of oil loss into the system if the source of buffer gas should somehow be reduced.



00620VP

FIG. 5 – EXTERNAL SUMP VENT EQUALIZING LINES, EXTERNAL BALANCE PISTON VENT LINES

**TABLE 4 – MAJOR COMPRESSOR PARTS**

ITEM	DESCRIPTION	ITEM	DESCRIPTION	ITEM	DESCRIPTION
1	GASKET, 1/32"	45	PIN, INSERT 1/4" X 38"	100	PLUG, PIPE, HEX SOC. CSK. HD. 1/4"
2	COUPLING, YORK FLEX, COUPLING SYSTEM	46	SCREW, CAP, 12 PT. HD., OIL, PUMP		PLUG, PIPE, 3/4" SQ. SOC. CSK. HD.
3	SHAFT, DRIVE, COUPLING SYSTEM	47	HOUSING, OIL PUMP, 1 PC.	101	NIPPLE, PIPE
4	COVER, BEARING HOUSING	48	GASKET, OIL PUMP HSG. 1/32"	102	SCREW, CAP, HEX HD.
5	GASKET BRG. HSG. COVER	49	GASKET, OIL PUMP HSG. 1/64"	103	WASHER, PLAIN
6	SCREW, CAP, 12 PT. HD.	50	GASKET, OIL PUMP HSG. .005"	104	GASKET
7	SCREW, CAP, HEX HD.	51	SCREW, CAP, 12 PT HD.	105	GASKET, COMPR. ENDS 1/32" THK.
8	GASKET SHAFT SEAL COVER 1/16"	52	HOUSING, OIL RESERVOIR	106	GASKET, COMPR. END 1/64" THK.
9	GASKET SHAFT SEAL COVER 1/32"	53	CONNECTION, SUCTION, OIL	107	COVER, SHAFT SEAL
10	GASKET SHAFT SEAL COVER 1/64"	54	ELBOW, 90 DEGREES, CINCH TYPE	108	SPRING, SHAFT SEAL
11	CASING	55	BODY, JET PUMP	109	WASHER, SPRING RETAINING
12	PIN, INSERT	56	GASKET JET PUMP	110	SEAL, O-RING
13	COLLAR, SHAFT SEAL	57	NOZZLE, JET PUMP	111	RING, SHAFT SEAL
14	PIN, INSERT	58	ELIMINATOR, MIST, SUMP VENT	112	SCREW, MACHINE, FLAT HD.
15	HOUSING, BEARING	59	GASKET, OIL SUMP HSG.	113	RING, RETAINING SEAL
16	BEARING, JOURNAL	60	COVER, OIL SUMP HSG.	115	DOWEL PIN
17	RING, RETAINING	61	GLASS, OIL SIGHT	116	NUT, HEX
18	SLEEVE, PRV HOUSING	63	SCREW, CAP, HEX HD.	150	ROTOR, ASSEMBLY
19	OIL RING, SEAL (SUCTION END)	65	SCREW, CAP, HEX HD.	151	DIFFUSER, DISK VANE
20	RING, RETAINING	66	ADAPTER, EQUAL, LINE	152	DIFFUSER, VANE ENTRANCE
21	SPRING, UNIVERSAL	67	VENT, INTERNAL TUBE	153	SCREW, CAP, HEX HD.
22	GASKET, PRV SLEEVE 1/16"	68	PLUG, PIPE 1/2 HX, SOC. HD.	154	DEVICE, PRE-ROTATION
23	GASKET, PRV SLEEVE 1/32"		PLUG, PIPE SQ. SOC. CSK. HD., 3/4"	155	RING, RETAINING
24	GASKET, PRV SLEEVE 1/64"	69	PIUG, PIPE SQ. SOC. CSK. HD., 1"	156	RING, LABYRINTH SEAL, EYE SEAL 1 <sup>ST</sup>
25	SCREW, CAP, HEX HD.	71	PLUG, PIPE SQ. SOC. HD. 3/4"	157	RING, LABYRINTH SEAL, EYE SEAL 2 <sup>ND</sup>
26	SCREW, CAP, HEX HD.	72	SEAL, O-RING	158	COVER, BAL. PISTON SEAL
27	GASKET COMPR. ENDS	73	SEAL, O-RING	159	RING, BAL. PISTON SEAL
28	HOUSING, PISTON RING	74	DISK, 3/8 DIA. X .0598 THK. (26")	160	WASHER, FLAT SPRING
29	SCREW, CAP, HEX HD.		DISK, 9/16 DIA. X .098 THK. (38")	161	SEAL, SHAFT, EXPLODED
30	LOCKWASHER, SPRING		DISK, 1-3/16 DIA. X 129 THK. (55")	184	ROLL PIN
31	RING, PISTON COMPRESSION	75	LABYRINTH, SHAFT	192	ROLL PIN
32	RING, SEAL (DISCHARGE END)	80	NAMEPLATE, PUBLICITY		
34	SPRING, UNIVERSAL	81	NAMEPLATE, PATENT		
35	RING, RETAINING	82	NAMEPLATE, INSTR. (ROTATION)		
36	HOUSING SEAL RING	83	GUARD, CPLG. H.S.		
37	SCREW, CAP	87	NAMEPLATE, DATA		
38	GASKET, SEAL RING HSG. 1/32"	88	SCREW, DRIVE TY. U #4 X 1/4" LG.		
39	BEARING, THRUST & JOURNAL	94	BUSH., PIPE, 1-1/4 NPTE X 3/4"+ NPTI OUTSIDE HEX		
40	PIN, INSERT	97	SCREW, CAP, HEX HD.		
41	PUMP, CENTRIF. OIL	98	PIN, INSERT		
42	RING, VOLUTE SEAL				
43	RING, INT. RETAINING				
44	BEARING, REVERSE THRUST				

Seals that are supplied from a source within the compressor are commonly identified as A-1 seals. Seals in compressors that utilize an external source of gas as a buffer are identified as A-4 seals. Source pressure for A-4 seals should be adjusted to the pressures defined on the oil flow diagram for the compressor.

**Atmospheric Shaft Seal (Figure 6) (Post 1970)**

Refrigerant leakage along the shaft to the atmosphere is prevented by means of a shaft seal assembly (1) which consists of a rotating cast iron shaft seal collar (2) with “O-ring” (3) and a stationary spring loaded carbon shaft seal ring assembly (4), consisting of small helical springs (5).

These springs keep the carbon shaft seal ring (6) in contact with the rotating shaft seal collar (2).

The shaft seal collar (2) rotates with the shaft (positive drive through the insert pins in the drive shaft), while the stationary carbon seal assembly is mounted on the shaft seal cover (7). Gaskets (8) are used to adjust the shaft seal installation dimension. These two parts are lubricated and cooled by the oil circulated through the seal cavity.

Some leakage of oil and dissolved process gas is normal and does not indicate a problem. Leakage rates are dependent upon coupling size, shaft rotational speed, and oil reservoir/sump pressure. Larger diameter and

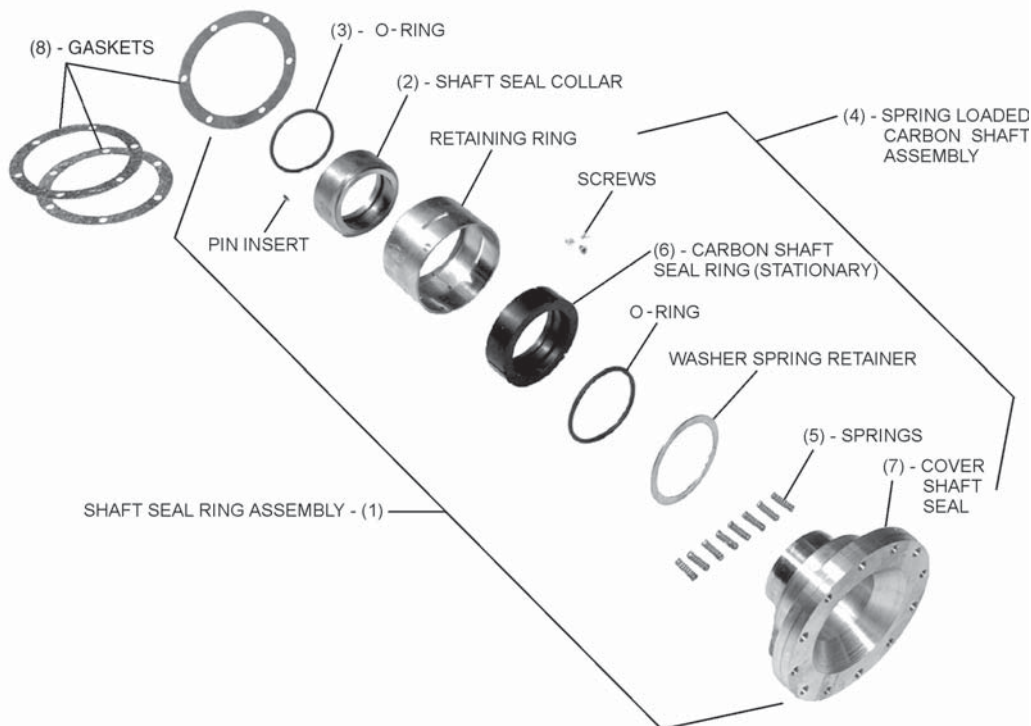
higher shaft speeds will result in more leakage through the seal faces.

Since oil leakage to the atmospheric side of the shaft seal is collected in the drain trap, a leaking shaft seal can be detected by a rapidly filling drain trap and a corresponding oil level drop in the compressor oil reservoir.

During operation, a small amount of oil dripping past the seal surfaces is normal. However, if it becomes necessary to drain the drain trap daily, the shaft seal is leaking excessively and should be replaced.

Since the seal parts “wear in” to each other during operation and since it is difficult to determine the exact location of the leak, it is recommended that the complete seal assembly (seal ring, seal collars and “O” rings) be replaced if excessive shaft seal leakage occurs. The spring(s) may be reused if it is not visibly damaged.

If a shaft seal failure occurs, the thrust bearing clearance should be checked. A thrust bearing failure may have caused the seal failure. The proper thrust clearance is shown in Table 12 for each compressor size. If a new thrust bearing is required, its clearance should be adjusted within the limitations shown.



**FIG. 6 – EXPLODED VIEW OF ATMOSPHERIC SHAFT SEAL**

00621VIP

## The Lubrication System

See Figure 7 for models with a Series lubrication system. See Figure 8 for models with a Parallel lubrication system.

The location of the auxiliary oil pump, within the system, determines whether the lubrication system is in Series or Parallel. If the auxiliary oil pump suction is through the centrifugal shaft driven pump discharge, the lubrication system is in Series. If the auxiliary oil pump suction is directly from the oil reservoir, the lubrication system is in Parallel.

The lubricating system consists of the shaft driven main oil pump (1), auxiliary oil pump (2), oil filter (3), oil cooler (4), the oil reservoir (5) and all interconnecting oil piping. There are four main points of lubrication, within the YORK Turbomaster Compressor, which must be supplied with forced feed lubrication by the main oil pump (1) and the auxiliary oil pump (2) as follows:

1. Thrust Bearings (6) (Active/Reverse)
2. Main Bearing – Suction End (7)
3. Main Bearing – Discharge End (8)
4. Atmospheric Shaft Seal (9)

The main oil pump (1) is a centrifugal type of YORK design. It is bolted to and is directly driven by a hex on the end of the rotor shaft. The auxiliary oil pump (2) is an electric type pump and is used to establish oil pressure before operating the compressor. It is typically mounted on the side of the compressor or on the base near the compressor.

## The Oil Circuit

To trace the oil flow through the compressor see Figure 7 for models with a Series lubrication system and Figure 8 for models with a Parallel lubrication system. The main oil pump (1) takes suction from the oil reservoir (5) and discharges through the oil filter(s) (3).

From the oil filter(s) (3), the oil flow is divided as follows:

1. Part of the oil flows to the discharge end main bearing (8) and thrust bearing (6).
2. The remainder of the oil flows to the suction end main bearing (7) to lubricate the main bearing and shaft seal.

At the discharge end, oil from the oil filter(s) (3) enters a drilled passage in the side of the oil reservoir housing (5) and flows to the space around the shaft between the thrust bearing (6) and the discharge end main bearing (8). From this space, part of the oil passes through the main bearing (8) toward the impellers and the remainder passes to the load surface of the thrust bearing (inboard surface of oil pump and outboard surface of thrust bearing).

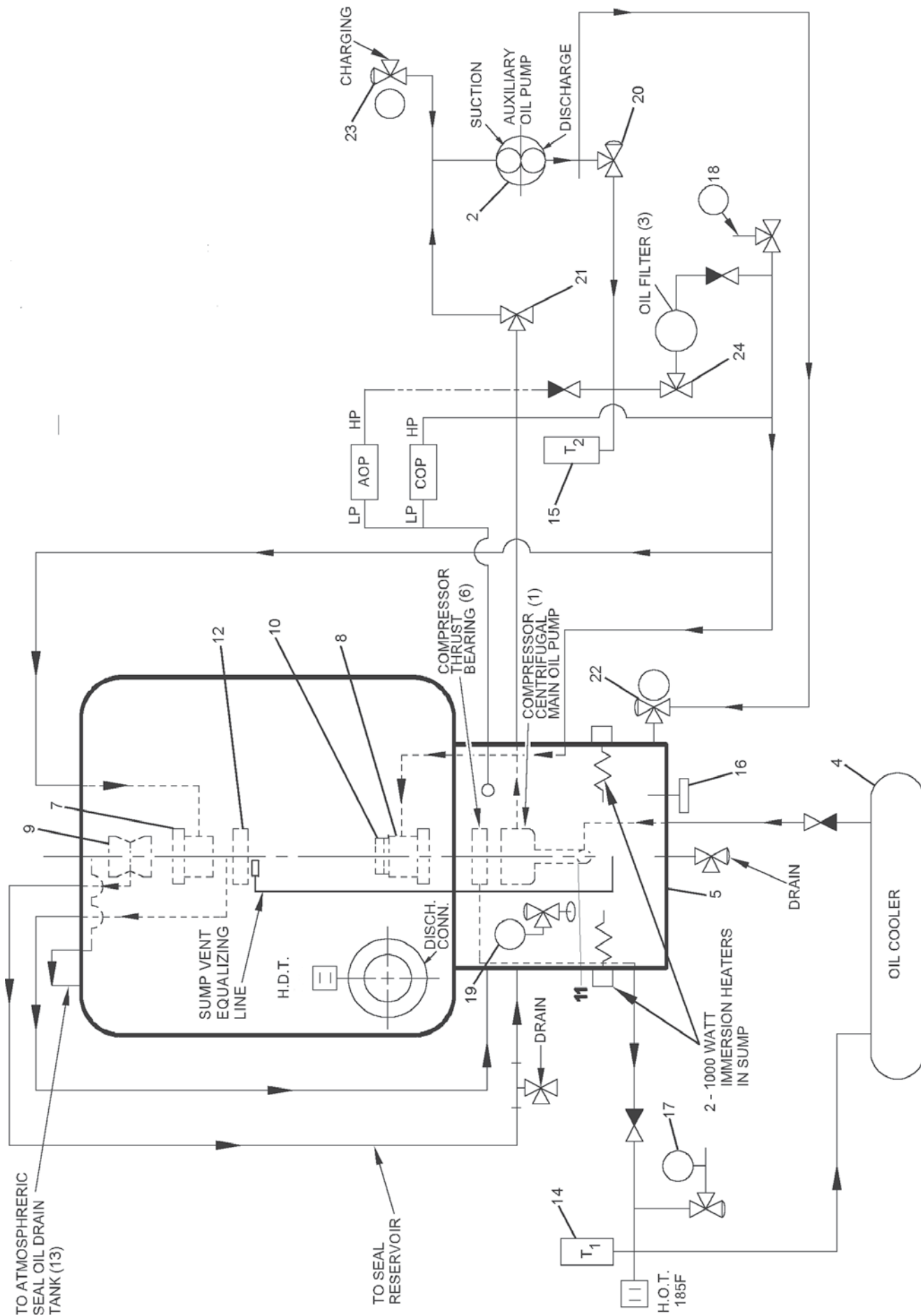
Oil passes through the discharge end main bearing (8) toward the impellers into the space between the oil reservoir (5) and seal ring housing. This oil drains into the oil reservoir (5). The discharge end oil seal (10) is so designed that some gas from the balance piston leaks into the oil reservoir (5). Typically the oil reservoir pressure is equalized with a low stage impeller inlet pressure as outlined under External Sump Vent Equalizing Line.

The oil which lubricates the thrust surface (inboard surface of oil pump and outboard surface of thrust bearing) flows through the cooler (4) and returns to the main pump (1) via the oil jet pump nozzle (11). As this oil flows through the jet pump (11), additional oil from the reservoir (5) is induced to flow to the main oil pump (1).

The oil which flows from the filter (3) to the suction end of the compressor enters the bearing housing and flows through a drilled passage to an annular space around the suction end main bearing (7). The main bearing (7) is drilled radially to permit the oil to flow into the bearing surfaces. Part of this oil flows through the main bearing (7) (toward the impellers and suction end oil seal (12)) and drains back to the reservoir (5) through the external oil return line.

The remainder of the oil in the suction end main bearing (7) flows into, and completely floods, the shaft seal space. From the shaft seal (9) the oil passes to the shaft seal cavity oil reservoir, with a small amount passing to lubricate “O-rings” in the PRV cover plate. Any oil leaking through to the atmospheric side of the shaft seal (9) drains by gravity to the oil recovery system, if equipped, or the atmospheric seal oil drain tank (13) which is cast into the underside leg of the compressor housing.

To facilitate checking oil temperatures in the lubrication system, thermometers (14, 15, and 16) are typically located as follows:

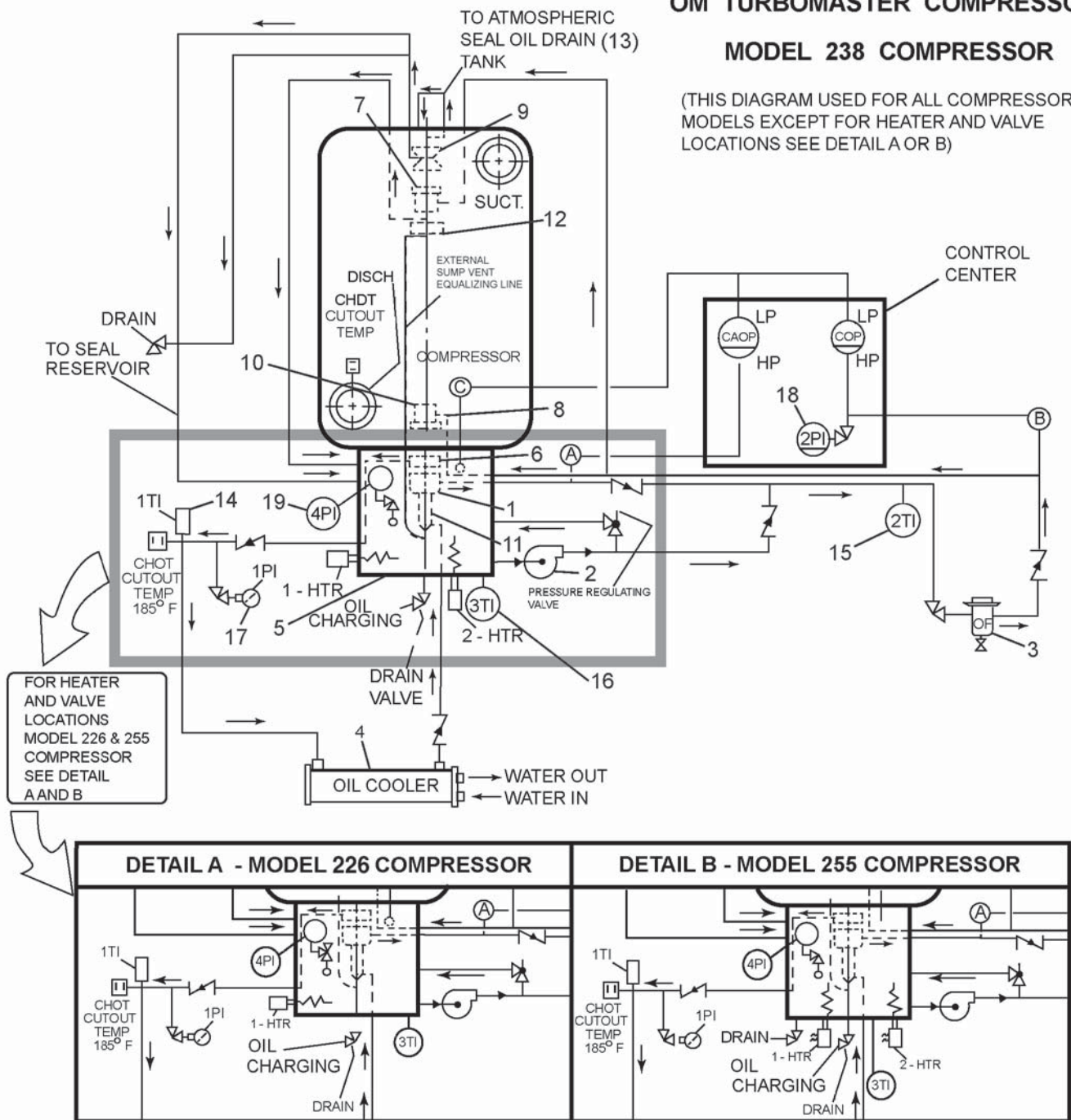


LD07320

FIG 7 - OIL PIPING SCHEMATIC FOR SERIES LUBRICATION SYSTEM (PRIOR TO 1970)

**TYPICAL OIL FLOW DIAGRAM  
OM TURBOMASTER COMPRESSOR  
MODEL 238 COMPRESSOR**

(THIS DIAGRAM USED FOR ALL COMPRESSOR MODELS EXCEPT FOR HEATER AND VALVE LOCATIONS SEE DETAIL A OR B)



LD07321

**FIG. 8 – OIL PIPING SCHEMATIC FOR PARALLEL LUBRICATION SYSTEM (AFTER 1970)**

1. A thermometer (14) is in the oil line leaving the thrust bearing (6).
2. A thermometer (15) is in the main oil line to the filter(s) (3) and the bearings.
3. A thermometer (16) is in the oil reservoir (5).



***On some series oil flow systems the thrust oil pressure gauge (17) and the bearing oil pressure gauge (18) may not be installed at the equipment. They may be installed at a remote location.***

To facilitate checking the pressures within the lubrication system pressure indicators (17, 18, and 19) are located as follows:

1. The thrust oil pressure gauge (17) is in the oil line leaving the thrust bearing (6).
2. The bearing oil pressure gauge (18) is in the main oil pump supply line from the oil filter(s) (3).
3. The compressor balance piston pressure indicator (19) indicates pressure within the balance piston chamber.

### STARTING THE COMPRESSOR

The following paragraphs describe the procedures for starting and operating a Turbomaster Compressor.

1. Before starting the compressor, perform the following steps:
  - A. If the compressor is turbine driven, warm up the turbine in accordance with the manufacturer's instructions.
  - B. Check the compressor oil level; it should be maintained at about 1/4" above the bottom of the upper sight glass during operation or at normal start-up mark for a rectangular reflex type of glass. The oil temperature should be at the specified standby temperature or 150°F minimum.
  - C. Add new oil of the proper YORK designation, if necessary (refer to Adding Oil to Compressor).
  - D. Start all system auxiliaries.

- E. If the compressor is motor driven, be sure the pre-rotation vanes are closed to unload the motor during starting. Some systems are equipped with a safety switch which automatically prevents the compressor motor from starting unless the vanes are closed. The starting requirements for a single shaft gas turbine are more severe and a special start-up procedure is required. With a steam turbine or a split shaft gas turbine, it is normally unnecessary to unload the compressor during starting.
- F. Open the water valves to the oil cooler. The full design flow of water is required through the oil cooler at all times during starting and operation to inhibit foaming in the oil, especially with compressors handling oil soluble gases, such as halocarbon refrigerants and hydrocarbons.
- G. If equipped, move the auxiliary oil pump switch from OFF to AUTOMATIC (See THE AUXILIARY OIL PUMP). This de-energizes the reservoir oil heater (See THE RESERVOIR OIL HEATER) and starts the pump, with most compressor control arrangements. (Refer to the wiring diagram and the application data sheet). The auxiliary oil pump builds up sufficient oil pressure to actuate the low oil pressure differential control, permitting the compressor driver to start.



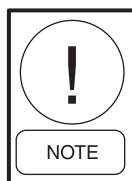
***Some control arrangements automatically start the compressor after a brief delay. Refer to the wiring diagram and the application data sheet.***

2. As soon as the low oil pressure differential control has been satisfied start the compressor.



***As the compressor comes up to speed, the oil pressure built up by the main oil pump will actuate the auxiliary oil pump differential control and stop the auxiliary oil pump.***





***During periods of low speed operation, the auxiliary oil pump may operate continuously. With a variable speed drive, the main oil pump will not stop the auxiliary oil pump at low speed. This is a normal condition.***

3. Check that the oil pressure has increased and that the auxiliary oil pump has stopped.



***When starting a warm system with a motor drive, the pre-rotation vanes must only be opened partially to avoid overloading the motor. On systems equipped with automatic pre-rotation vane control, the vane opening should be limited automatically to prevent motor overload.***



***Opening the pre-rotation vanes, as soon as the compressor comes up to speed, will reduce the tendency of the oil to foam during starting and minimize the opportunity to surge the compressor.***

4. Open the pre-rotation vanes as soon as the compressor comes up to speed.
5. Be sure that oil foaming is visible only in the upper region of the oil reservoir. The lower region should show nearly clear oil.
6. If foaming becomes visible in the lower region and adversely affects oil pressure, stop the compressor immediately to prevent excessive foam from entering the main oil pump suction at the jet nozzle.



***During operation, foaming of the oil at the jet nozzle/body is controlled by cooling the oil.***

7. Opening the pre-rotation vanes and cooling of the oil by the oil cooler will both reduce oil foaming and oil pressure fluctuations.
8. Be sure the water valves to the oil cooler are wide open and that the design flow of water is passing through the cooler. It may be necessary to throttle water to the coolers when the compressor is to operate at reduced speeds, such as during turbine warm-up.



***During the "idle" period, with variable speed drive, the main oil pump will not produce sufficient pressure to stop the auxiliary oil pump due to low speed. This is a normal condition.***

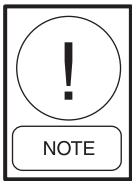
9. If, during a shutdown period, the reservoir heater fails to function or if there is not sufficient time to allow the heater to heat the oil, drain the oil from the reservoir and replace with new oil of the proper YORK designation before starting.

#### SUMMARIZED TYPICAL STARTING PROCEDURE

1. Be sure a full flow of water is flowing through the oil cooler.
2. Move the auxiliary oil pump switch to AUTOMATIC and turn off the oil heaters, if manually controlled. (Refer to the wiring diagram and the application data sheet).
3. Start the compressor shortly after starting the auxiliary oil pump.
4. **Stop the compressor** if oil foaming is visible in the lower sight region and adversely affects the oil pressure. Do not wait for the oil failure switch to function.

#### DAILY OPERATION

During operation, the following conditions should be checked daily:



***The compressor is equipped with a safety switch to stop the compressor if the temperature of the oil leaving the thrust bearing exceeds 185°F.***

1. Check the temperature of the oil leaving the thrust bearing; it should not exceed 185°F. (The main oil supply temperature should be 100 - 140°F.)



***The rise for thrust oil outlet above supply oil temperature will be 10°F to 45°F, depending upon speed and load.***

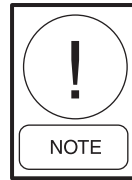
- A. A temperature differential of less than 10°F may indicate a worn volute seal between the main oil pump discharge and thrust bearing.
  - B. A temperature differential above 45°F may indicate excessive load or insufficient oil circulation, which may be due to a plugged oil filter (refer to Replacing Oil Filter Element).
2. Check the temperature of the oil supply to the bearings; it should not exceed 140°F.
    - A. A higher temperature indicates inadequate oil cooling. Check the oil cooler water supply and clean the water sides of the oil cooler, if necessary.
    - B. Do not throttle the oil cooler. Oil cooling inhibits oil foaming. An exception is when a turbine is being operated at its "idle" speed.



***Oil supply pressure at the filter outlet will vary with speed – 30 to 260 psi above suction pressure from low to high speed respectively. This variation in pressure is tailored to meet bearing requirements at different speeds. Oil pressure will be reduced slightly as the vanes are closed or as the oil temperature is increased. The oil pressure will fall if the filter becomes clogged with dirt and sludge.***

3. If oil pressure falls, the oil filter element must be changed before the oil pressure differential falls to

80% of its normal value, (refer to Replacing Oil Filter Element).



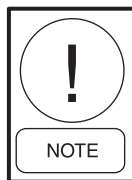
***Compressors on which the oil reservoir pressure can fall below atmospheric should be equipped with a shaft seal oil pressure gauge and regulating valve.***

4. Adjust the regulating valve to maintain a seal pressure of 2 to 5 psi at minimum suction pressure. The actual seal oil pressure will vary with suction pressure and the pre-rotation vane position; closing the vanes reduces seal pressure.
5. The shaft seal will drip a slight amount of oil to the atmospheric trap built into the side of the compressor housing. Normally, this leakage is very slight and this oil should be discarded. (Refer to Atmospheric Shaft Seal in this section.)
6. The compressor is equipped with a pressure gauge to measure balance piston pressure. This pressure depends upon the stage to which the balance piston is vented (refer to Balance Piston) and varies with compressor suction and discharge conditions. Over a period of time, increasing balance piston pressure could be an indication of balance piston seal wear. Increasing balance piston pressure results in increased thrust load to the thrust bearing.
7. Check the upper sight glass for the reservoir oil level. The oil level is normal when it is visible in the upper sight glass. If the oil level becomes visible in the lower glass, add oil. If the sight glass is a reflex type the oil level should be above minimum or at normal. Especially before attempting to start the compressor.



***Maximum compressor discharge temperature must not exceed 300°F for aluminum impeller wheels; 600°F for steel impellers. Based on metallurgical limitations, there may be other factors that further limit maximum discharge temperature. All compressors are equipped with a safety switch to stop the compressor if the discharge temperature exceeds its limit, which is speed dependent (refer to the application data sheet).***

8. Check if the suction temperature is excessively high to cause elevated discharge temperature.



***The minimum compressor discharge temperature depends upon discharge pressure and the gas being compressed.***

9. If 10°F of discharge superheat, as a minimum, cannot be maintained check the system for possible liquid entrainment, unless liquid injection is used for noise suppression.

### THE AUXILIARY OIL PUMP

The Auxiliary Oil Pump (2, Figures 7 & 8) is typically mounted on the side of the compressor. This pump is automatically controlled, through the auxiliary oil pressure differential switch mounted on the compressor, or in the Control Center.

The primary function of the auxiliary oil pump is to automatically furnish oil to the compressor lubrication system on start-up while the main oil pump is coming up to speed, on shutdown while the rotor is coming to rest, or at any time during operation if the main oil pump fails to produce adequate pressure. In addition this pump was used to charge oil into the reservoir of series piped systems.

On variable speed drives, the auxiliary oil pump may also operate at very low compressor speeds when the main oil pump can not develop adequate oil pressure.

On series arrangements this pump is equipped with two separate suction connections as follows:

1. From main oil pump discharge (21).
2. From oil charging valve (23).

The auxiliary oil pump (2) has two discharge connections with stop valves (20 and 22) which are connected into the main oil pump discharge ahead of the oil filter (3) and into the oil reservoir (5) for oil charging.

1. The discharge stop valve (24) ahead of the oil filter (3) should never be closed except while servicing the auxiliary oil pump or charging oil.
2. During normal operation, the auxiliary oil pump suction (21) and discharge valves (20) should be open to permit proper automatic pump operation. The other pump connection should be closed.

3. The Hand-Automatic Switch should be set at “Automatic” during operation, except as noted in Adding Oil To Compressor.

### Adding Oil To Compressor for a Series Oil Flow System

1. Maintain the operating oil level of this compressor at approximately 1/4 inch above the bottom of the upper sight glass (Figure 2).
2. When the oil level falls so that it is not visible in the top sight glass, add oil as follows:



***The oil capacity is 10 gallons for 26 inch compressors, 35 gallons for 38 inch compressors, and 50 gallons for 55 inch compressors using integral lube piping systems. When adding or changing oil, use only YORK Compressor Oil of the proper designation specified for the application.***

- A. Close auxiliary oil pump discharge valves (20) and auxiliary oil pump suction valve (21).
- B. Open oil reservoir return valve (22).



***To prevent the entrance of air into the system, be sure the open end of the charging line is immersed in the container of oil and crack open the charging valve (23). Oil or gas can then bleed back through the charging line to displace the air.***

- C. Submerge the oil charging line in a clean oil container. Be sure to check the container for any evidence of contamination.
- D. Slowly open valve (23) and bleed oil or gas back through the line to displace the air and not to disrupt the normal lubrication system. Close valve (23) when bleeding is completed.
- E. Start the auxiliary oil pump (2) manually.
- F. Open valve (23).



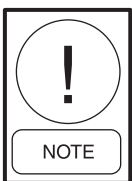
***The normal pressure differential on the auxiliary oil pump internal relief valve is 60 psi (if so equipped).***

- G. If the pressure in the oil reservoir (5) is higher than 60 psi set the auxiliary oil pump internal relief valve higher to charge oil. Alternatively, use the YORK Hand Oil Pump (P/N 470-10654) to add oil through the drain valve.
- H. Close valve (23) before the oil container is completely empty or when a sufficient quantity of oil has been added.
- I. Stop the auxiliary oil pump (2) and close valve (22).
- J. Open valves (20) and (21).
- K. Turn the auxiliary oil pump switch to automatic.
- L. Close and seal the oil container immediately.

**Adding Oil To Compressor for a Parallel Oil Flow System**



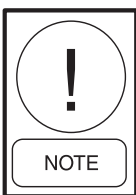
*Compressors manufactured before 1997 will have two circular sight glasses. The normal oil level should be maintained at a level within the lower half of the upper sight glass. The compressor oil pressure safety may not permit the compressor to operate if the level falls into the bottom sight glass.*



*Compressors manufactured after 1997 may use a reflex type sight glass and the oil sump cover will be marked with normal start-up and minimum low oil levels.*

Before operating the compressor, the proper quantity and type of oil should be charged into the system using the YORK Oil Charging Pump (P/N 070-10645).

1. Check that the unit is shut down.



*If oil must be added while the unit is in operation, extra care must be exercised to prevent a nuisance shutdown.*

2. Verify that the pump and attaching hose and hardware are clean and free from contaminants.
3. Inspect the oil container for any sign of foreign material or contamination.

4. Immerse the suction connection of the oil charging pump in a clean container of oil. Be sure the oil is the proper YORK designation for the application.
5. Connect the pump discharge connection to the oil charging valve located at the end of the compressor oil sump. Be sure the connections are rated for the design pressure of the system. Do not completely tighten the connection at the charging valve until all of the air is forced out and oil is forced out by pumping a few strokes of the pump. This fills the lines and prevents air from being pumped into the system. Exercise extreme care if the unit is operating.
6. Open the oil charging valve and carefully pump oil into the system until the oil level is at the normal mark or one-half of the upper sight glass.
7. Close the oil charging valve.
8. Disconnect the oil pump and secure the oil pump and storage container to prevent contamination.
9. As soon as the oil charging is complete, and the unit is not operating, the power supply to the oil heaters should be energized (normal standby temperature is 150°F). This will keep the concentration of refrigerant in the oil reservoir to a minimum.

When the compressor is initially charged with oil, the auxiliary oil pump should be operated to fill the lines, passages, oil cooler(s) and filter(s). This may lower the oil level in the oil sump. It may be necessary to add oil to restore the level for proper operation.



*Record / log all oil added/removed from compressor.*

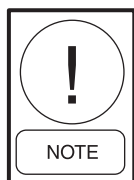
**THE RESERVOIR OIL HEATER**

During periods of shutdown, the oil in the reservoir tends to absorb as much gas as it can hold, depending upon the temperature of the oil and the pressure in the reservoir.

As the temperature of the oil is lowered, the amount of gas absorbed will be increased. If the quantity of gas in the oil becomes excessive, violent oil foaming will result as the pressure within the system is lowered on starting. The foaming is gas formed by evaporation at the lower pressure. This condition may cause the oil pressure from the pump to fluctuate with possible temporary loss of lubrication.

To keep this gas concentration to a minimum during shutdown, one or more thermostatically controlled oil heaters are installed in the oil reservoir housing. These heaters are factory set at 150°F. Some 26 inch compressors are equipped with a 450 watt heater in the seal trap which is not thermostatically controlled.

1. If the heaters are controlled by a manual switch:
  - A. Turn heaters on during shutdown.



*The oil should be at the standby temperature of 150°F before attempting to start the compressor. Failure to do so may result in oil pressure fluctuations and oil failure switch initiated safety shutdown.*

- B. Turn heaters off during operation.

2. If the heaters are automatically controlled check that they are functioning properly. (Refer to the wiring diagram and the application data sheet.)

**CONTROLS**

Each compressor should be equipped with the following controls:

**Auxiliary Oil Pump Differential Control**

**Location**

The auxiliary oil pump differential control switch is mounted on the side of the compressor or in the Control Center. Whenever this switch is mounted in the Control Center, it is important that the correct size tubing be used. (See SIZING THE OIL LINES FOR OIL PRESSURE SWITCHES).

**Function**

It automatically starts the auxiliary oil pump whenever the main compressor oil pump does not maintain a normal operating pressure.

The auxiliary oil pump differential control switch is actuated by the pressure differential between the oil reservoir and the main oil pump discharge, sensing the output of the main oil pump only, independently of the auxiliary pump.

**Adjustments / Settings**

This control should be adjusted, depending upon compressor size as follows:

**TABLE 5 – AOP DIFFERENTIAL SWITCH SETTINGS**

COMPRESSOR SIZES	OPEN (PSID)	CLOSE (PSID)
26A 38A 55A	40	35
26B 38B 55B	55	48
ALL AFTER 1995	33	30

For compressors manufactured after 1995 the AOP regulating valve should be adjusted to produce a 33 PSID rise in oil pressure over sump pressure (at standby).

**Low Differential Oil Pressure Control**

**Location**

The low differential oil pressure control switch is mounted on the compressor or in the Control Center. (Tubing size may be a concern for protection monitored in the Control Center.)

**Function**

It automatically opens the compressor driver control circuit and stops the compressor if the oil pressure to the compressor bearings falls below a safe operating minimum. It is actuated by the pressure between the oil reservoir and the filter outlet, sensing the combined output of both the main and auxiliary oil pumps.

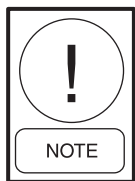
**Adjustments / Settings**

The low differential oil pressure control should be set to stop the compressor if the differential pressure (between oil reservoir and oil filter outlet) falls to the differentials listed below, unless indicated otherwise on the lubrication oil diagram:

**TABLE 6 – LOW OIL DIFFERENTIAL OIL PRESSURE SWITCH SETTINGS**

COMPRESSOR SIZES	OPEN (PSID)	CLOSE (PSID)
26A 38A 55A	27	30
26B 38B 55B	40	43
ALL AFTER 1995	23	20

**SIZING THE OIL LINES FOR OIL PRESSURE SWITCHES**



*Sizing the oil lines to the bellows of the control, as outlined, will minimize the pressure drop in these lines and permit the switches to detect the pressure changes more quickly, avoiding the possibility of damage to the compressor bearings due to slow acting switches.*

When the oil pressure switches are shipped separately, for remote mounting, all the lines to the control bellows should be sized as follows, depending upon the length of the tubing required to connect the control bellows to its point of sensing:

**TABLE 7 – OIL PRESSURE SWITCH TUBING SIZING**

LENGTH OF LINE	TUBING SIZE
0 FT. TO 15 FT.	3/8"
15 FT. TO 45 FT.	1/2"

**PRE-ROTATION VANE OPERATION**

If the system is automatically controlled, the pre-rotation vanes should automatically modulate in accordance with load requirements.

If the pneumatic system fails, and the compressor is equipped with a hand wheel, adjust the pre-rotation vanes manually as follows:



*Operation of the compressor in the manner will require constant monitoring of compressor operation to allow changing of PRV position if local conditions change.*

1. Disconnect the linkage to the vane motor.
2. Connect the linkage to the hand wheel, located on a bracket at the coupling end of the compressor.
3. Turn the pre-rotation vane hand wheel. A pointer is mounted on the operating linkage and the open, closed and reverse positions (“O”, “C” and “R” respectively), are stamped on the arc of pointer travel. Turning the hand wheel so that the pointer moves past the open position to “R” reverses the angularity of the vanes and changes the pre-rotation

tion of the suction gas entering the first stage impeller. Under certain conditions, this will increase compressor capacity (refer to the application data sheet). There may be an adverse impact on power.

**Air Pressure**

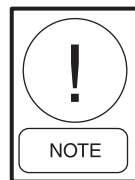
If the compressor is equipped with an air motor for automatic pre-rotation vane operation, the supply air pressure to the motor should be **CLEAN, DRY AIR**, at 100 PSIG maximum and 50 PSIG minimum for 26 inch compressors, 60 PSIG minimum for 38 inch compressors and 70 PSIG minimum for 55 inch compressors.

Air consumption will vary from 0.40 to 0.80 cfm depending upon the air supply pressure.

**STOPPING THE COMPRESSOR**

To properly shut down the compressor, proceed as follows:

1. Stop the compressor driver.



*If the compressor stops due to a power failure, the auxiliary pump can not start. This should not damage the compressor because the main oil pump will supply oil while the compressor slows down, and residual oil will prevent bearing damage.*

2. As the compressor slows down, the main oil pump pressure falls until the auxiliary oil pump starts automatically. The control system may also automatically start the pump on a command to shut down.
3. After the compressor driver stops, a check valve in the compressor discharge line, when required, may minimize reverse rotation of the compressor (caused by gas equalizing from the discharge to the suction through the compressor). If interstage inlets are applied, an automatic valve should close to halt the flow of gas, which may cause reverse rotation.
4. If either automatic pre-rotation vanes or automatic hot gas bypass are employed, a solenoid valve in the air signal line closes the vanes. In some refrigeration applications the system valve sequence should be tailored and controlled to prevent the freezing of water cooled components, due to the potential for low settleout pressures. Certain applications may require additional consideration for draining liquids to protect them from freeze damage.

This page intentionally left blank

## SECTION 4 SERVICE

### GENERAL

Service on these compressors consists essentially of maintaining the lubrication system (auxiliary oil pump, filter and cooler) and replacing the various seals and bearings.



*When the system is open for repairs, it is important to keep the gas side of the compressor as clean and dry as possible. Keep all openings covered except while actually working on the unit.*

Before installing new parts, thoroughly clean the parts and apply a light coating of Liquid Molycote (Part No. 013-00834-000) to the balance piston seal ring, shaft seal labyrinths and impeller labyrinths. Apply Molycote Paste, Part No. 360-00125, to the impeller eye diameter and the shaft area under the floating aluminum shaft seals.

The journal bearings and balance piston drum diameter shall be pre-lubricated with a light coating of Molybdenum Disulfide Powder, Part No. 364-21508-000 (2 oz. tin).

### SERVICE TIPS

Practices that should be followed in disassembly and reassembly of the compressor are as follows:

#### Do Not Mix Parts

Keep parts in some general order when removing them from the compressor. It is suggested that parts be laid out to follow exploded views as shown in the illustrations outlining the disassembly and assembly of the various parts.

#### Do Not Mix Cap Screws and Washers

Cap screws and like parts of a length, material, and heat treatment are suited to the location in which they are used. Too long or too short a cap screw can result in leakage or interference with some interior parts. It is very important to use correct washers or lockwashers. The parts list and figures on the compressor drawing shows the correct length and size of screws and washers. See the drawing supplied with job to order the correct numbers.

### Inspect as Compressor is Disassembled

Once compressor parts have been disassembled and cleaned, valuable indications of the compressor condition are lost. For example: Materials found in oil often indicate as to why a part or parts have failed.

### Protect Parts and Surfaces

Do not scatter removed parts indiscriminately. Coat machined surfaces likely to rust with YORK Oil or a rust preventive. Protect surfaces subject to scratching or nicking during repair operations. Plug any oil passages likely to accumulate dust or abrasives.

### Clean Thoroughly

No compressor is completely overhauled if it is not cleaned internally to "new part" condition. Dirty parts cannot be inspected nor fitted and will cause excessive and/or premature wear when the compressor is in operation. The oil cooler and interconnecting lines must also be cleaned.

### Cleaning and Checking Wearing Parts

Before reassembling the compressor, all parts should be thoroughly washed with an approved safety solvent.

During reassembly, carefully check each part for signs of uneven wear, bearing in mind that a polished surface is not an indication of excessive wear. Sudden excessive wear on any part of the compressor is not normal. It is usually caused by some other condition which must be determined and corrected to assure trouble free operation.

Worn parts should be replaced with new parts and each new part should be thoroughly examined for shipping damage.

While the compressor oil sump is open, carefully wash with an approved safety solvent, clean with a lint free cloth, and oil with YORK Oil of proper designation. Clean and check all oil passageways and tubing.

Before assembling parts, all friction surfaces such as bearings and moving parts should be lightly coated with the appropriate lubricant. Be sure to use YORK Oil of proper designation. Bearings and seals should be replaced with new parts. All gaskets and O-rings should be replaced after compressor disassembly to ensure proper sealing of surfaces.



**TABLE 8 – MAINTENANCE REQUIREMENTS FOR YORK MULTISTAGE CENTRIFUGAL COMPRESSORS**

PROCEDURE	DAILY	WEEKLY	MONTHLY	QUARTERLY	SEMI-ANNUALLY	YEARLY	EVERY * HOURS
	24 HRS.	160 HRS.	1000 HRS.	3000 HRS.	3000 HRS.	6000 HRS.	
Check oil level – record any additions / removal	X						
Check refrigerant charge		X					
Check and repair leaks ^		X					
Check vibration levels		X					
Check alignment / couplings						X	
Perform analysis on compressor lube oil ^				X			
Replace oil and filters						X	
Record / evaluate system pressures / temperatures	X						
Test / calibrate all safety controls^ and gauges						X	
Sample / analysis refrigerant chemistry						X	
Replace system filters / driers and clean strainers					X		
Replace A4 gas filter						X	
Replace oil return filter						X	
Check / drain seal oil trap	X				X		
Check / clean oil cooler							
Check relief devices		X					

\* Reserved for any special site determined requirements.

^ This procedure must be performed at the specified time interval by an Industry Certified Technician who has been trained and qualified to work on this type of YORK equipment. A record of the procedure being carried out must be maintained on file by the equipment owner should proof of adequate maintenance be required at a later date for warranty validation purposes. This procedure must be performed more frequently if refrigerant losses exceed 10% of system charge.

## HOW TO IDENTIFY PARTS

Figure 4B is a cutaway sectional view of a two stage Centrifugal Compressor. The parts are identified by number and are described in the accompanying parts list. Table 4 is provided for reference only. To order parts for your YORK compressor refer to the part numbers in the installation drawings for your specific unit. Always refer to the compressor serial number when inquiring about parts for a multi-stage compressor.

## ROUTINE MAINTENANCE INSPECTIONS

Refer to Table 8 for the minimum recommended maintenance actions and intervals for YORK Multistage Centrifugal Compressors. Many potential compressor difficulties may be avoided by following a regular Inspection and Maintenance program.

## PREVENTATIVE MAINTENANCE CHECK

Before disassembling the compressor, check with the unit operator. Review the cause of the current shutdown and the history of previous shutdowns. Inspect the log sheets and other records to determine if proper preventative maintenance has been performed in accordance with Table 8. Historical information in the log sheets may indicate possible causes of unit shutdown such as;

losing oil at light load, faulty or worn suction end shaft seal, etc.

Also check the following:

- A. Oil Filter Element – Check for any particles of metal. Any evidence of aluminum particles may be an indication of bearing wear.
- B. Control – Check that the control that caused the shutdown is operable and at the specified setpoint.
- C. Maintenance – The frequency of oil and oil filter element changes, cleaning water side of oil cooler, cleaning air filters in control circuit.
- D. Air – Check air pressure to control circuit and PRV actuator.
- E. Calibration – Check the frequency of control calibration.

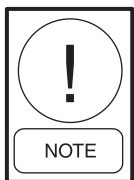
Compare the compressor shaft alignment to the original, or subsequent, alignment records. Improper alignment could increase vibration (driver, gear, and compressor), wear and/or damage to compressor, driver and gear parts (i.e. seal). See Form 160.71-N2 for proper alignment procedures. If alignment tolerances do not coincide with the alignment records, determine the reason and correct to the required by hot check.

After all checks are made and it has been determined that compressor servicing is necessary then proceed per the following instructions to remove and replace the necessary parts. Checks should be made during this procedure such as observing wear patterns, all clearances, evidence of unusual material foreign to the compressor, etc.

## PREPARATION FOR SERVICE

Read the general introductory information and specific service instructions for intended task. Be sure you understand all the above items thoroughly, if you need assistance, call the local YORK office. As mentioned before, have an as-built print, proper tools, and parts on hand.

Always follow tag out/lockout procedures to prevent unexpected operation.



***Be sure you know the exact type of refrigerant and oil in the system you are working on. Be sure proper replacement stocks are available.***

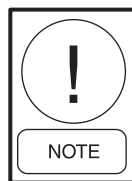
To ensure compliance with the Clean Air Act and still provide efficient refrigerants, manufacturers are frequently bringing out new products. These rather exotic compounds and blends are similar in performance to the older series of refrigerants, but they are not considered to be “drop in” replacements.

Newly developed HFC and HCFC refrigerant compounds and blends, together with some synthetic oils, are not compatible with most of the older types. In addition, elastomers and gasket materials used prior to 1992 that were recommended for specific refrigerants and applications may not be suited to the new products.

Be sure you know the exact type of refrigerant and oil that is in the system on which you are working, storage containers are available and suitable, and proper replacement stocks are available if required.

As of November 1994, the EPA requires certification of all personnel engaged in service of air conditioning and refrigeration systems. A set of specific guidelines has been issued by the EPA and failure to comply with these standards may result in penalties in the form of fines per day to the service technician or service company. The EPA standards are revised frequently and it is the responsibility of the service technician and his/

her organization to be aware of current regulations and to comply with them.



***Be careful that the system is not subjected to a freeze condition during the transferring of refrigerant.***

Be sure that rigging provided is rated for the Series M compressor components. For example; a 55" two-stage top half weighs more than three tons. Consult Table 2 and Table 3 for approximate component weights.

Use gantries with chain falls or overhead cranes if possible. Mobile cranes and fork trucks are subject to abrupt movements. If cranes or fork trucks must be used, utilize them with chain falls for delicate positioning.

Use extreme caution when rigging the total compressor weight off the top half casing lugs. Attachment rigging may be steel cable, chain, or approved straps. Be sure of the rigging working strength and pay attention to lifting angles which may derate this devices.

When lifting the casing top half, it is recommended to rig from a center point to the four casing lugs. Secure the four lines from the casing hooks at the center point with a large shackle to prevent the lines from running through the hook and allowing the casing to abruptly shift. Use one or more come-a-longs rigged off of the lifting hook to level the top half if needed.

Depending upon the compressor location, local weather or job hazards, the compressor may be relocated into a maintenance shop. Compressor realignment is not difficult nor time consuming. You may actually save time as well as having better conditions for a successful overhaul.

Have sufficient guide pins on hand. You need four bullet-nose pins for the top half and at least three pins for the PRV housing and sump. The suction and bearing support and shaft seal cover are heavy and requires at least two guide pins. The oil pump housing requires at least two pins. An alternate source is all-thread studs used to bolt up high pressure flanges. Be aware of the thread pitch so the housings are not damaged by cross threading. The overall length and positioning will vary with the oil piping and control locations. When removing or installing the sump, it may be necessary to screw a short stud into one of the bottom bolt holes at the rear of the sump and slip a piece of pipe over it to get lever-

age so the sump can be maneuvered up and down. It may sag down to the rear from the eyebolt and needs leveling. Special care must be taken to protect the oil seals from damage during this process. Use protective sleeves to protect probes, if applicable. Failure to comply will result in damage to probes.

All compressor components are drilled and tapped for lifting eyes. Use forged eyebolts and make sure they are screwed into the shoulder. Use washers if required. Extended shanks can bend and break. Don't use home-made lifting eyes. Use only approved devices rated for the weight of the component being lifted.

Utilize containers to segregate bolts, screws and washers. Keep a log and true count of all small items. Coat all parts with oil and cover with paper or plastic for protection from weather or dirt.

### SERVICE REQUIRING OPENING THE COMPRESSOR

Before opening the compressor, try to determine if you really need to go inside the machine. Some of the valid reasons requiring internal inspection or repairs are listed below:

- A. Excessive shaft seal leakage of oil or refrigerant.
- B. Routine bearing inspection.  
(Customer requested/mandated)
- C. Aluminum particles in the oil filter.



***Thrust oil to the oil cooler is not always filtered. Small amounts of aluminum may be signs of significant thrust bearing failure.***

- D. Oil loss into the compressor.
- E. Rapid or gradual increase in compressor vibration.
- F. Excessive balance piston pressure relative to the equalizing stage.
- G. High discharge temperature relative to the suction and side load temperatures.

The conditions listed above are some of the more common symptoms and problems. Some of the possible causes are listed below.

Conditions A, B, and C can be checked without removing the compressor drive shaft. If condition C reveals particulate aluminum in the oil filter, it is advisable to drain the oil and inspect the thrust bearing and journal bearings.

Condition D may require removal of the compressor drive shaft and suction end bearing housing if external factors, such as oil dilution, sump pressure and external seal gas pressure (A-4) seal are found to be correct. Scoring or wearing of the suction end inboard A-1 oil seal can result in oil loss into the compressor and you must pull the PRV sleeve to verify it.

Condition E can be caused by poor alignment, extreme variations of oil pressure and temperature, liquid refrigerant entering the compressor suction or side loads, displaced oil pump collar if observed by vibration probes or unbalanced rotor. Rotor unbalance may be the result of excessive bearing wear, wheel erosion, encrustation of wheels with system dirt, physical damage to the wheels from foreign objects or contact with an internal part the compressor and/or excessive balance piston wear. The rotor can make contact with the compressor internals if severe thrust bearing failure occurs. Severe discharge and thrust bearing failure may also cause the discharge end inboard gas seal to fail and cause excessive foam in the oil sump. Balance piston wear is usually the result of excessive surging, liquid refrigerant carry-over, or system dirt entrained in the gas flow. The top half must be lifted if rotor damage is suspected.

Condition F is suspected if the balance piston chamber pressure is more than 10 lbs above the design pressure or the delta approaches the maximum value listed on the drawing, assuming all external conditions are normal. A rising balance piston pressure coupled with an increase in thrust oil temperature to more than 25°F above the supply oil temperature to the bearings, indicates the thrust bearing is carrying increasing thrust load. A worn balance piston seal ring is the most probable cause. The sump must be removed to reach the balance piston and discharge end gas seals.

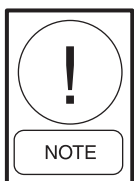
Condition G may indicate excessive shaft labyrinth seal and/or impeller inlet seal(s) wear. Assuming external conditions are normal, the condition will usually be accompanied by a loss in compressor capacity and possibly a rise in discharge temperature along with an increase in compressor horsepower. The compressor top half must be lifted for inspection of the shaft and impeller seals. Analyze for elevated system temperatures before condemning the compressor efficiency.

The common causes of the compressor problems listed above are not the only ones. Be sure to exhaust all of the external possibilities by means of appropriate testing before opening the compressor for service.

## USE OF COMPRESSOR TOOLS

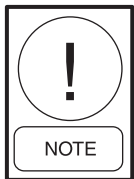
Special tools are furnished with each compressor (see Table 9). The wrenches (1) are used for removing the driven coupling disk nut from the compressor drive shaft (see Fig. 9), and for removing the driven coupling disk from the driver (speed increaser, turbine, etc.). These wrenches and wrench support (Table 9, Item 2) and main shaft wrench (Table 9, Item 6) are used to remove the compressor drive shaft from the compressor main shaft.

### Removing the Driven Coupling Disk



***Follow safety guidelines to isolate machine from operating.***

1. Remove both coupling guard halves and associated supports (See Figs. 10 and 11). Although matching marks are not a requirement, marking part locations with a marking pen will allow the parts to be reassembled in the order they were removed.
2. Loosen and remove the hex socket screws, nuts and washers.
3. Place the compressor side clamp ring onto the drive shaft.



***Use 12-point wrench on coupling nut. Remember these are double lead left handed threads at the driver, 12 pt. nut and drive shaft to rotor interface.***

4. Install the wrenches (Table 9, Item 1) as shown in Fig. 9. Use drive thread compound on the special trunnion screw.
5. Loosen the coupling nut and remove the wrenches.
6. Screw the nut onto the drive shaft to allow the spacers to be removed. Be careful not to let the driven compressor disk fall to the floor.
7. Remove the driven compressor disk and spacers.

### Removing the Drive Coupling Disk

1. Be sure the clamp ring is in the driven disk.
2. Install the wrenches (Table 9, Item 1) with the 12-point wrench on the hex of the drive coupling half. The wrench will not bear on the entire flat of the hex on the driver extension.
3. Loosen the drive coupling disk and remove wrenches.
4. Move clamp ring onto the driver shaft.
5. Remove the drive coupling disk and clamp ring.

### Removing Compressor Drive Shaft

The removal of the drive from the compressor requires the use of special tools, (See Table 9). To remove the drive shaft use the following procedure:



***Follow safety guidelines to prevent compressor from operating.***

1. Remove the coupling guard. (See Fig. 10)
2. Remove the 12-point nut holding the coupling to the shaft.
3. See Removing the Driven Coupling Disk.
4. Remove the shaft seal cover and seal. (See Removing the Shaft Seal)
5. Reinstall the 12-point nut on the compressor drive shaft.
6. Install the support wrench (Table 9, Item 2) as shown in Fig. 11 and Fig. 13 – Detail A. Install wrenches (Table 9, Item 1 and 6).
7. Disconnect the electrical wiring to the oil heaters. (Make sure fused disconnect switches are open.)
8. Remove refrigerant charge. See Preparation for Servicing Compressor, and drain oil.
9. Remove the oil sump cover.
10. See Removing and Replacing Oil Pump. Remove the jet pump, associated piping, the centrifugal oil pump and thrust bearing (See Replacing Oil Pump and Thrust Bearings and Oil Sump Main Bearing).
11. Install the main shaft wrench (Table 9, Item 6) as shown in Fig.13 – Detail B.
12. Remove the drive shaft by turning the special screw to loosen the drive shaft.
13. Remove wrenches.
14. Remove coupling nut.
15. Remove compressor drive shaft.

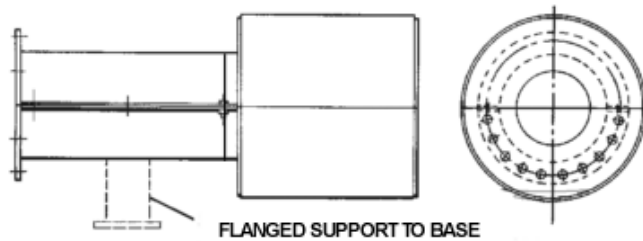


00622VIP

**TABLE 9 – COMPRESSOR TOOLS**

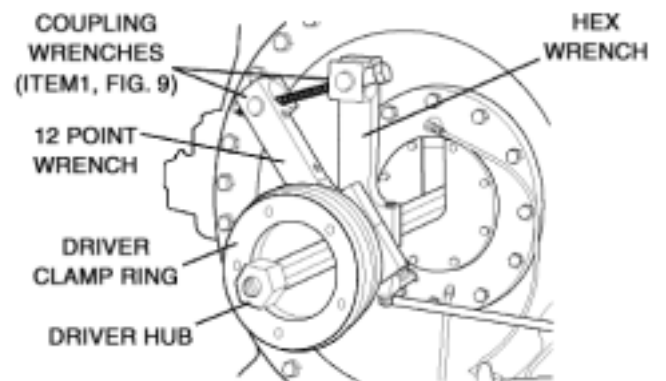
ITEM	DESCRIPTION	QTY
	TOOL KIT	1
1	WRENCHES	1
2	WRENCH SUPPORT	1
3	GUIDE PIN	4
4	SNAP RING PLIERS	1
5	SNAP RING PLIERS	1
6	MAIN SHAFT WRENCH	1
7	SNAP RING PLIERS	1
8	THREAD COMPOUND	1
9	HEX CAP SCREW	3
10	HEX CAP SCREW	4
11	OIL PUMP (HAND)	1
12	STUD GUIDE BEARING HOUSING	4
13	SLEEVES AND MANDRELS	1

**FIG. 9 – COMPRESSOR TOOLS  
(DEPENDING ON MACHINE SIZE)**



LD07322

**FIG. 10 – COUPLING GUARD**



LD07323

**FIG. 11 – COUPLING WRENCH APPLICATION  
FOR LOOSENING THE COUPLING NUT  
AT DRIVE SHAFT**

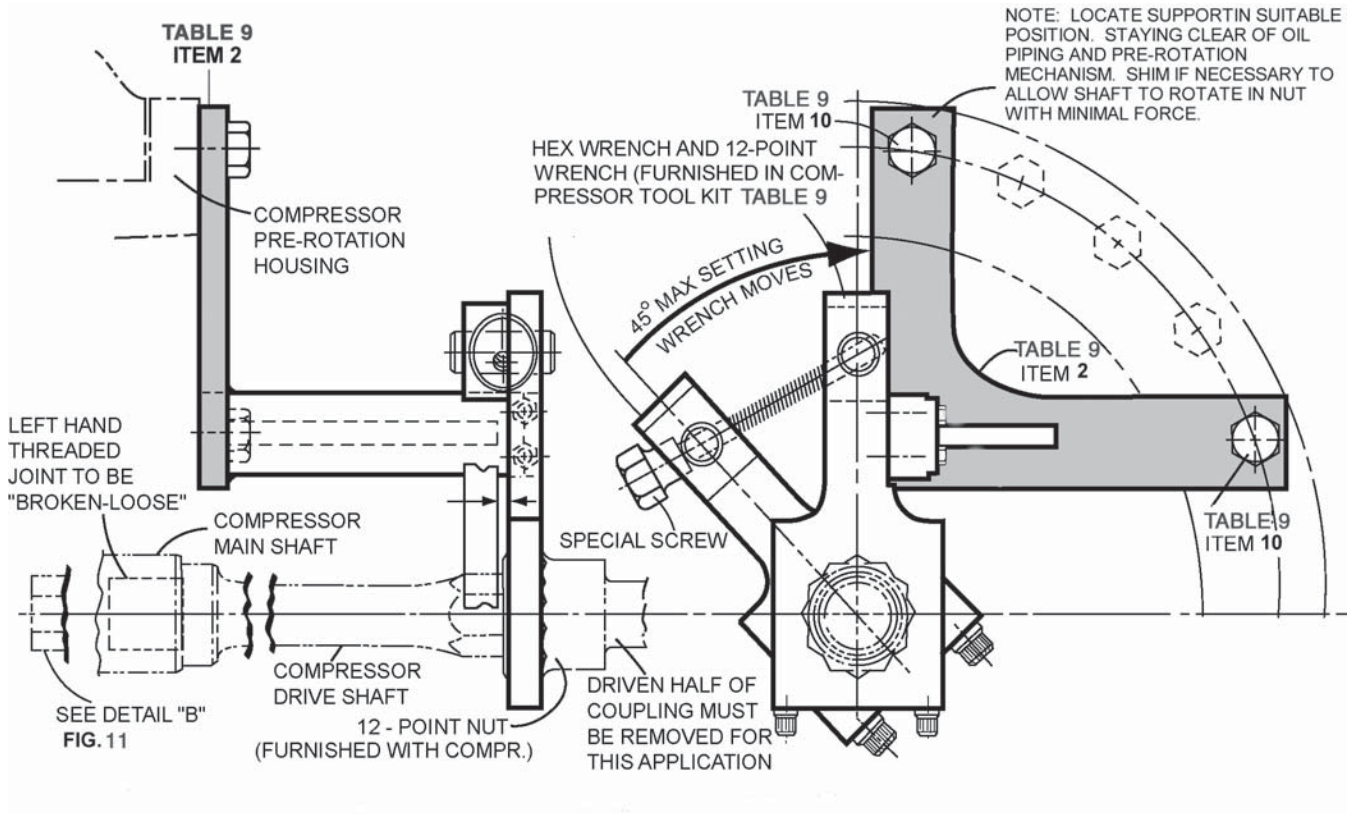
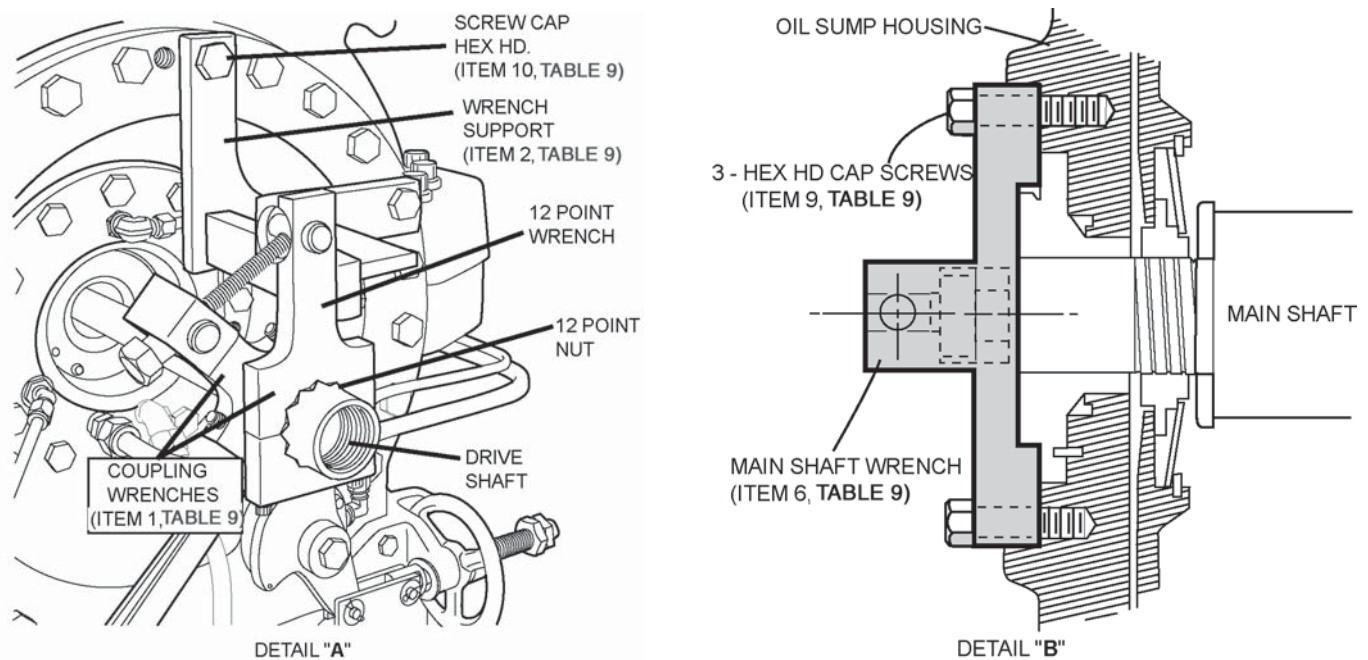


FIG. 12 – LOOSENING THE DRIVE SHAFT WITH SPECIAL WRENCHES



LD07325

LD07326

FIG. 13 – LOOSENING DRIVE SHAFT WITH WRENCHES

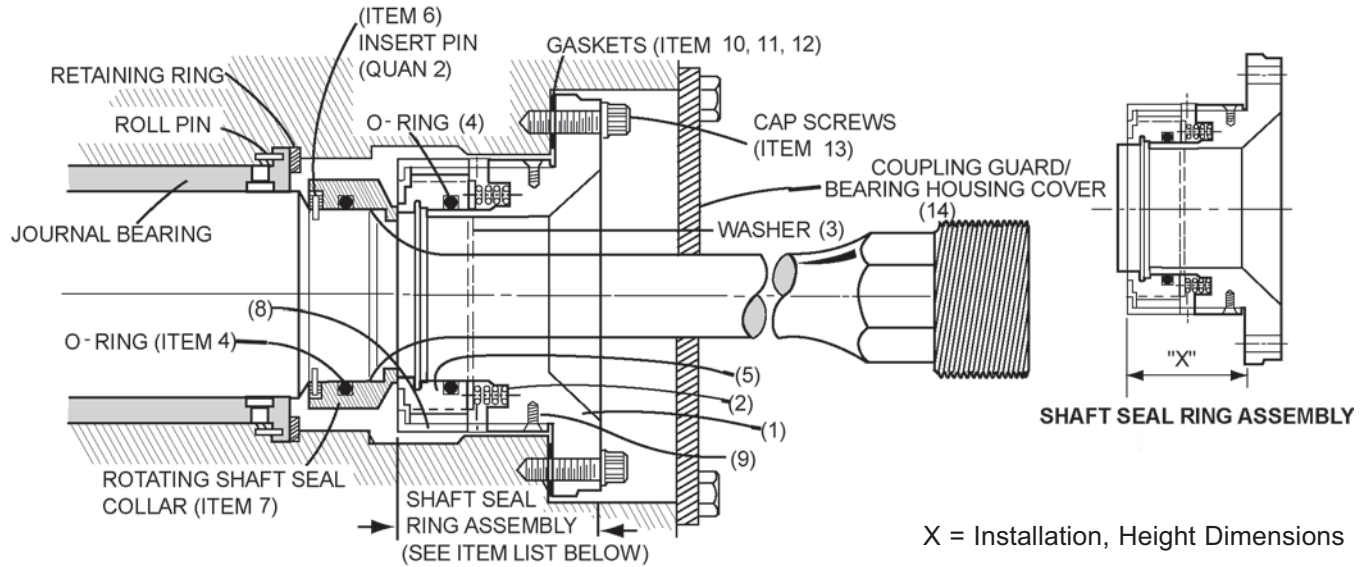


FIG. 14 – SHAFT SEAL PARTS

LD07327

TABLE 10 – SHAFT SEAL PARTS

ITEM	DESCRIPTION
1	COVER, SHAFT SEAL
2	SPRING, HELICAL
3	WASHER, SPRING RETAINING
4	O-RING
5	RING, SHAFT SEAL
6	PIN, INSERT
7	COLLAR, SHAFT SEAL
8	RING, RETAINING SEAL
9	SCREW, MACH. FLAT HD.
10	GASKET, 1/64" THK.
11	GASKET, 1/32" THK.
12	GASKET, 1/16" THK.
13	SCREW, CAP, 12 PT. HD.
14	COUPLING GUARD / BEARING HOUSING, COVER PLATE

**SHAFT SEAL REPLACEMENT**  
(REFER TO FIG, 11)

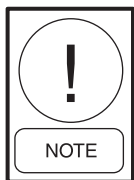
During operation, a small amount of oil dripping past the seal surfaces is normal. The rate is dependent on speed, pressure, and size. Oil leakage to the atmospheric side of the shaft seal is collected in the drain trap. If it becomes necessary to drain the drain trap daily, the shaft seal should be replaced.

Seal parts “wear in” to each other during operation and it is difficult to determine the exact location of leaks. It is recommended that the complete seal assembly (seal ring, seal collar and O-rings) be replaced if excessive shaft seal leakage occurs. The springs may be reused if not visibly damaged.

If a shaft seal failure occurs, the thrust bearing clearance, alignment, and coupling spacing should be checked. A thrust bearing failure may have caused the seal failure.

If it becomes necessary to replace the shaft seal, refer to Figs. 11 - 15 and proceed as follows:

**Removing the Shaft Seal**

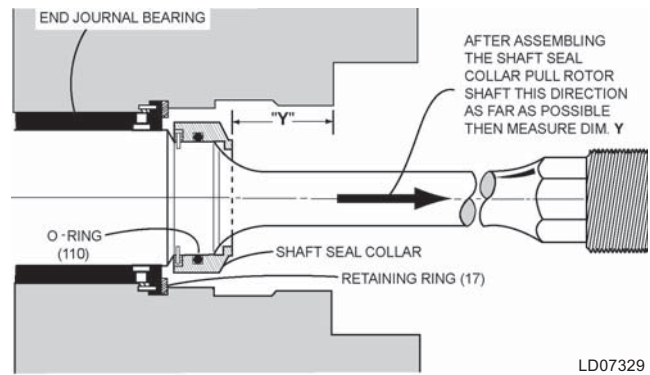


*If sump is vented to atmosphere, the shaft seal can be changed with oil in the main compressor sump. The shaft seal reservoir will have to be drained.*

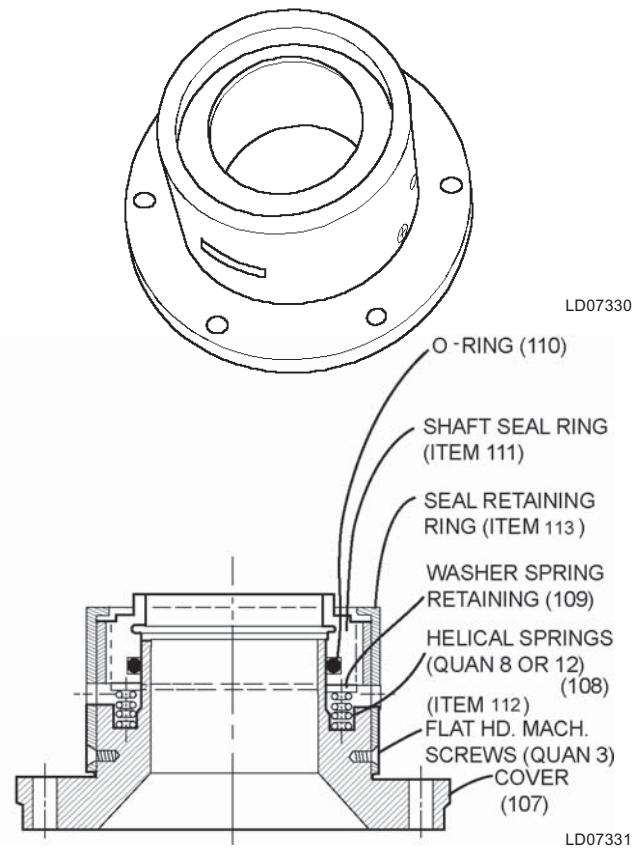


*Follow safety guidelines to isolate machine from operating.*

1. To facilitate shaft seal replacement with minimum loss of gas and oil, the unit should be pumped down to remove refrigerant (See Preparation for Servicing) and drain oil from the compressor.
2. Remove the coupling guard. (See Table 8)
3. Remove the driven coupling disk (Refer to Fig. 9). Only the driven coupling disk needs to be removed for seal and suction end journal bearing replacement.
4. Remove the coupling guard/bearing housing cover plate, if equipped (see Fig. 14B, Item 14)



**FIG. 15 – ASSEMBLING SHAFT SEAL COLLAR**



**FIG. 16 – SEAL RING ASSEMBLY**

**TABLE 11 – TYPICAL SHAFT SEAL INSTALLATION “HEIGHT” DIMENSION**

DRIVE SHAFT AND COUPLING THREAD SIZE (INCHES)	INSTALLATION HEIGHT OF SEAL (INCHES)	DRIVE END MAIN BEARING DIAMETRAL CLEARANCE (SMALL END) (INCHES)
1-1/2	1-25/32	.002 - .004
1-7/8	2-13/32	.0025 - .0055
2-1/2	2-13/16	.003 - .005
3	3-1/32	.004 - .006
3-3/4	3-11/32	.006 - .008



5. Loosen the cap screws which secure the shaft seal cover plate and carefully loosen the plate using jack screws so that the oil in the seal cavity can drain. Place a bucket under the seal cavity to catch draining oil.
6. Carefully remove the shaft seal ring assembly after the oil from the seal has drained. Examine the seal ring sealing surface to possibly determine the cause for the seal leaking. (See Fig. 14B, Item 5).
7. Pull the shaft seal collar (7), with its O-ring (4) off over the coupling end of the shaft. Two pieces of steel tubing (flattened at the end and bent to form a hook) may be used to pull the collar loose.
8. Disassemble the seal ring assembly as follows:
  - A. Remove the three flathead machine screws (9).
  - B. Carefully pull seal retaining ring (8) off the cover (1).
  - C. Carefully pull the shaft seal ring (5) from the cover and remove the O-ring (4) from the slot on the inside of the shaft seal ring.
  - D. Remove the spring retaining washer (3) and the springs (2).
9. Examine the insert pins (6) located on the shaft, if no damage is evident leave pins in place. If it is necessary to replace the pins, remove the drive shaft to prevent damage during pin removal. (See Removing Drive Shaft.) If insert pins are damaged, pull with pliers being careful not to damage the finished surfaces of the drive shaft. When insert pins are pulled replace with new pins.

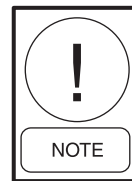
### Installing the New Shaft Seal

To install the new seal assembly, refer to Figs. 14, 15 and 16 and proceed as follows:

1. Be sure that the drive shaft under the seal area is smooth and free of burrs. Thoroughly coat the new seal parts with new compressor oil of proper designation.
2. Insert the O-ring (4) in the carbon seal ring.
3. Place a pencil mark on the new shaft seal collar (7), but not on the seal surface, to locate the slots (Refer to Fig. 14B). Carefully slide the new shaft seal collar (7) less O-ring (4) on to the enlarged shoulder on the inboard end of the drive shaft so that the two slots (marked by a pencil) slide over the insert pins, the inside surface of the collar is against the rotor shaft, and the rotor is on its active thrust face, shaft out. Measure "Y" per Fig. 15. Remove shaft seal collar (7) from shaft and reassemble with O-ring (4) installed in shaft seal collar

(7). Measure "Y" per Fig. 15. The "Y" measurement should be the same as the first measurement assembled without O-ring (4). The collar must not be cocked on the shaft and the O-ring must not be pinched between the edge of its groove and thread shoulder of the shaft. If this happens, the O-ring will be cut and a new O-ring must be used. Repeat measurement "Y" to ensure proper seating of the shaft seal collar. If "Y" is less, then the shaft seal collar is not seated properly. If "Y" is greater, the rotor possibly moved off its active face. If not repeat Step 3, etc. to the end of this paragraph.

4. Installation height "X". Refer to Fig. 16 and the compressor drawing and use the following formula:



***"X" is the dimension of the seal when assembled in the compressor. It is not the measured dimension of the seal assembly on the "bench". Figures 14 & 16 depicts the carbon ring being depressed into the retainer to the installation height. Failure to install the seal assembly to the specified Dimension "X"  $\pm 1/64$  may result in premature failure or excessive leakage of the seal. If dimension in table differs from drawing use the drawing dimension for "X".***

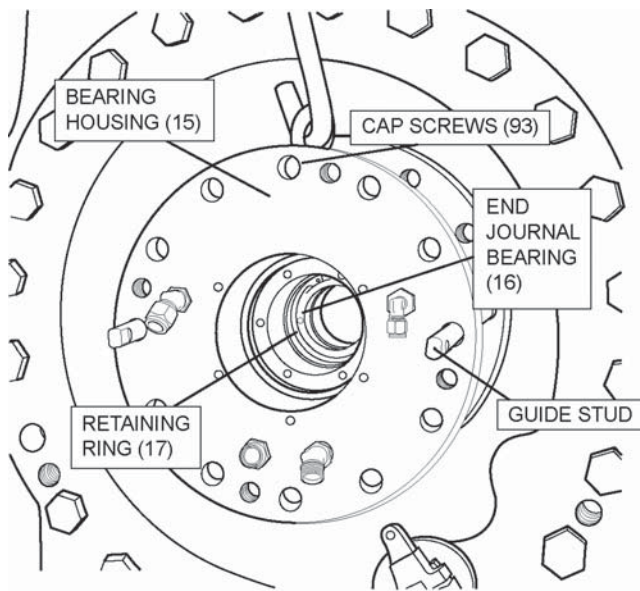
"X" – "Y" (from Fig. 13 or drawing) = Gasket thickness to be used  $\pm 1/64$  inch.

5. Assemble the shaft seal ring assembly and gasket(s) in the compressor. (See Fig. 16 for shaft seal parts identification.)



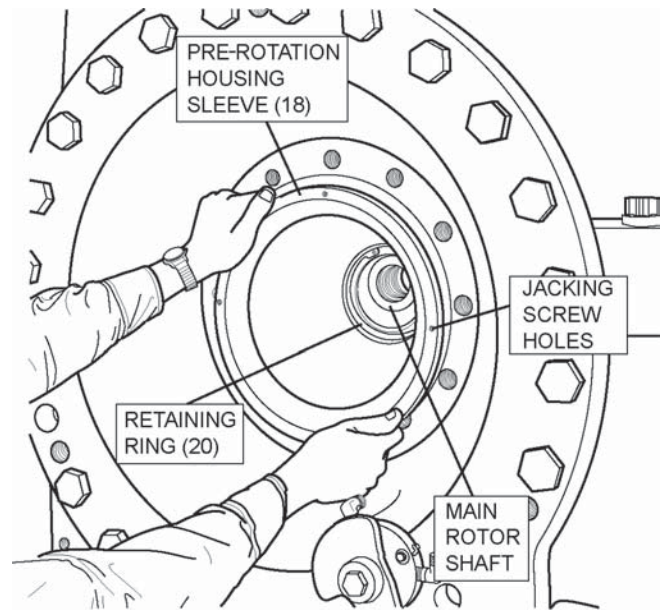
***When pulling the cover plate into place by tightening the cap screws evenly, be careful to prevent cocking the plate and damaging the carbon seal ring.***

6. Reassemble the flexible coupling. Check and record coupling alignment (see Form 160.71-N2).
7. Install coupling guard. Pressure test and evacuate unit per instructions.
8. Restore the oil level in the reservoir (see Adding Oil to the Compressor) and recharge system with proper amount of refrigerant.



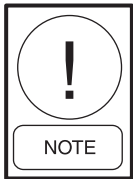
LD07332

**FIG. 17— REMOVING THE DRIVE END JOURNAL BEARING ASSEMBLY**



LD07333

**FIG. 18 – REMOVING THE DRIVE END OIL SEAL ASSEMBLY**



**Remove one end bearing at a time, replacing same before removing the other bearing.**

NOTE

### REMOVING SUCTION END JOURNAL BEARING

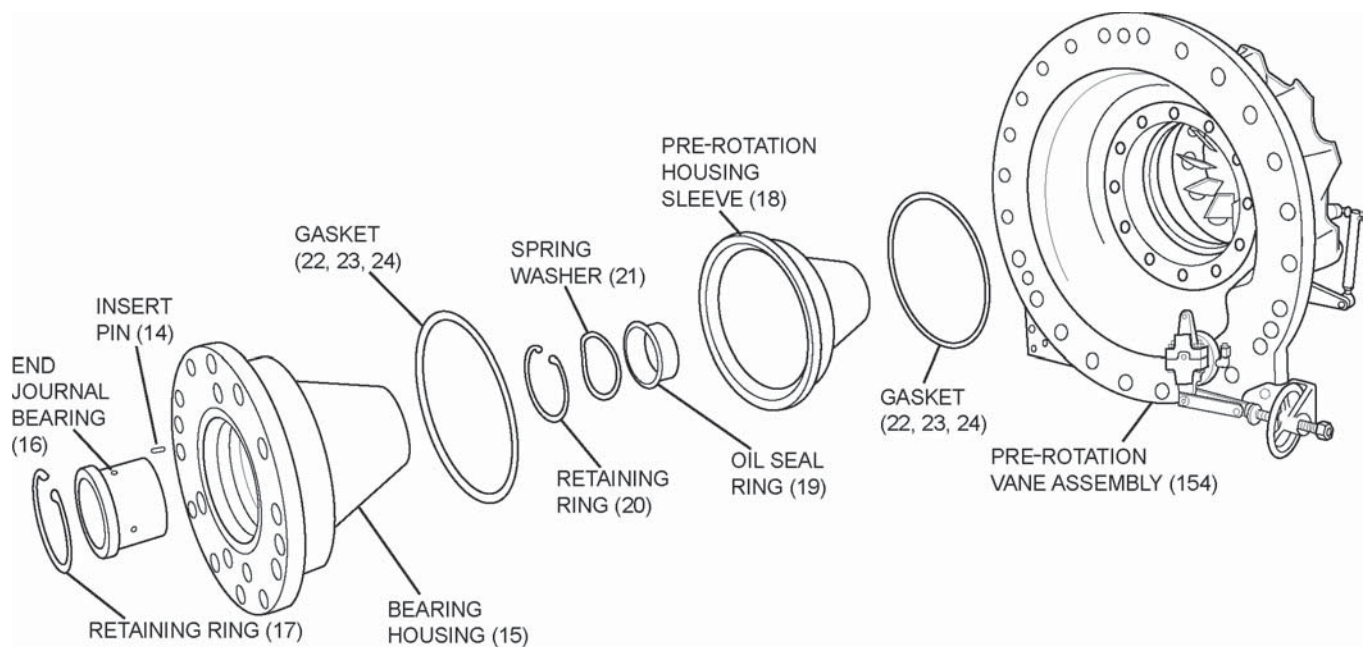
The actual bearing can be removed without removing the bearing housing which is described in this section. To replace the drive end journal bearing (16) refer to Figs. 17, 18, and 19 and proceed as follows:

1. See section on Preparation for Servicing. Transfer refrigerant from unit to storage receiver. Drain oil from compressor.
2. Remove coupling guard and driven coupling disk. (See Removing Driven Coupling Disk.)
3. Remove the shaft seal. (See Shaft Seal Replacement.)
4. To remove the suction end journal bearing proceed as follows:
  - A. Remove snap ring (17), using snap ring pliers supplied with compressor tools.
  - B. To remove the bearing, install screws in tapped holes in bearing (see Table 13 for screw size). Apply a slight upward force to the drive shaft and pull bearing from the bearing housing using the screws as handles.

- C. Suction end journal bearings are designed in several styles, taper bore and taper land are most common. Taper bore has a smooth single surface ID that actually tapers end to end. The taper land journal bearing ID has been machined so most of the bearing area has been relieved to form three dams or pockets offset at 120°. The inboard and outboard ends of the bearing have pressure dam areas to hold oil within the bearing. Both styles of suction end journal bearings are located radially by a roll pin at 12 o'clock fitted into a slot in the bearing flange. The pin location is critical for a taper land bearing application.
- D. Examine the bearing and determine the extent of any damage. Look for imbedded particles and scoring, evidence of plastic flow, extreme wear at some radial point, grey powdery residue, and erosion in the external annular oil groove. Also check that the locating pin has not sheared off allowing the bearing to spin.

Foreign material infiltrating the oil supply system is the most likely cause of scoring. Check that an oil filter is in the housing.

Plastic flow indicates the bearing has experienced extremely high temperature, usually due to poor lubrication. It may also show breakdown of bearing with particles circulated



4

LD07334

**FIG. 19 – EXPLODED VIEW, PRV AND OIL SEAL ASSEMBLY**

through the lubrication system. If particles are present in the sump and seal reservoir, inspect and flush the entire lubrication system.

Some slight radial wear could be normal, if at 6 o'clock on an old machine. This is the gravity position of the rotor. Misalignment can cause radial wear at any point.

A grey or white residue may indicate that water or another contaminate was in the lubrication oil at some time.

### REPLACING SUCTION END JOURNAL BEARING

To replace the suction end journal bearing:

1. Reinstall drive shaft if previously removed.
2. Examine bearing for nicks and burrs. Carefully remove all sharp edges with a scraper. Coat the bearing O.D. and housing ID with oil. Coat the bearing ID and the shaft journal with Molycote and oil.

Clean the drive shaft and tape the threaded area.



***Do not force the bearing into position. It must slip in easily. The bearing and housing should be at the same temperature when assembling.***

3. Slip the bearing over the drive shaft and screw the bearing puller rods into the bearing. Line up the bearing slot with the locating pin and push the bearing into position. Raise the shaft slightly to ease installation.
4. Use the snap ring pliers to place the snap ring into the groove in front of the bearing and lock it into place.
5. Replace the shaft seal (refer to Installing the New Shaft Seal, and Alignment Instruction Form 160.71-N2). Check the coupling alignment and realign if necessary.
6. Evacuate and test the unit per instructions.
7. Charge unit with oil of proper designation.
8. Transfer refrigerant from the receiver to the unit and check for refrigerant leaks.

### REMOVING SUCTION END OIL SEAL

If not already prepared see Preparation for Service, and follow safety precautions. To remove the suction end oil seal (19), refer to Fig. 19 and proceed as follows:

1. Remove the compressor drive shaft, (See Removing Compressor Drive Shaft).

2. Remove the suction end journal bearing (See Removing Suction End Journal Bearing).



***Check the as-built prints carefully. If the compressor has suction end proximity probes, the special sleeve must be installed in place of the shaft bearing to protect the probes during removal of the bearing housing. If sleeves and mandrels are not available at site contact the nearest YORK office for replacements.***

3. Remove the oil tubing and seal gas lines from the bearing housing and seal them to prevent contamination.
4. Remove the cap screws that hold the bearing housing (15) on the PRV housing. (Refer to Fig. 19).
5. Install the guide pins to hold the housing in place when it is loosened. Use cap screws as jack bolts. Remove the housing (15) and PRV sleeve gaskets (22, 23, 24). Record thickness and number removed.
6. A-1 seal removal and replacement.
  - A. Pull the PRV sleeve housing carefully over the shaft. Use suitable threaded rod as jack screws to pull out and hold the sleeve. Place the housing with the small end down on a bench or board. Remove the inboard sleeve gaskets (22, 23, 24). Record number and thicknesses removed.
  - B. Use snap ring pliers to remove the retaining ring (20) and then remove the universal spring (21) from the PRV sleeve housing.
  - C. Pull the seal ring from the sleeve housing.

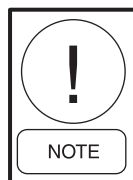


***Older units used variable sleeve gaskets to establish a set squealer clearance between the compressor rotor and PRV sleeve. On these units the PRV sleeve housing extends beyond the inner end of the seal ring. Thrust bearing wear or high superheat may allow the rotor to contact the sleeve housing. Particles rubbed off during contact will erode the oil seal, causing oil loss during operation. Carefully examine the PRV sleeve housing and rotor shoulder for evidence of rubbing.***

- D. Examine the seal ring flange and PRV housing mating surface for evidence of wear or scoring (use bluing if necessary). The inboard surface of the seal flange must sit flat within the PRV sleeve recess. The oil seal is a stationary seal. If it rotates you should see evidence of it. Just a slight deviation from a flat seal can promote oil loss, Inspect the ID of the seal ring for erosion. Dirt from the pressuring stage can erode a seal, resulting in oil loss.

To install the new seal ring assembly and gaskets.

- A. Assemble a new seal ring (19), universal spring (21) and snap ring (20) into the PRV sleeve housing. If the seal ring is excessively loose use a second universal spring to tighten the seal ring. The seal ring must be able to move with some minimal radial force.
- B. Install the inboard PRV sleeve gaskets (22, 23 or 24).
- C. Lubricate the ID of the seal ring and the rotor shaft with Molycote and oil.
- D. Assemble the PRV sleeve housing into the PRV housing. On large machines (38 and 55 inches) the sleeve is a heavy item, be careful as you slide it over the compressor shaft. After the seal is started over the rotor shaft, screw the drive shaft into the rotor a couple of turns and lift the rotor as you slide the sleeve in to it's full depth.
- E. Install new gaskets (22, 23 or 24), same number and thickness as you removed, otherwise the axial rotor clearances and seal deck will be changed.
- F. Install bearing housing, see step 9 on page 45.



***The A-4 seal is a dual spring tensioned seal. Individual rings are occasionally different lengths. Check the rings carefully to ensure they are replaced in the proper position.***

7. A-4 seal removal and replacement.
  - A. After protecting the rotor shaft, use pulling rods to remove the A-4 seal sleeve. Note the full bodied gasket and alignment roll pin. There is a specific location for the buffer gas flow to pass through the gasket.

- B. Slide the A-4 seal off the rotor shaft.
  - C. Pad the shaft again and using the pulling rods remove the PRV sleeve housing. Record the thickness and number of both inboard and outboard gaskets.
  - D. Examine and clean the A-4 seal as you would the A-1 seal. These seals must be flat and fit within the sleeve recesses with proper spring tension to hold their location.
8. Installation of the new seals.
- A. The new seals may be supplied as assemblies or as individual components. If field assembly is required, carefully follow the instructions on the as-built compressor drawings.
  - B. Pad the rotor shaft, install the PRV sleeve with correct new gaskets.
  - C. Remove the shaft pad. Coat the A-4 seal assembly ID and the rotor shaft OD with Molycote and oil then slide the seal into position in the PRV housing sleeve.
  - D. Pad the rotor shaft again and slide the A-4 seal sleeve into position over the A-4 seal. Line up the roll pin to approximately 12 o'clock and install the new full bodied gasket.
- TIP:** Remove the A-4 seal inlet gas fitting from the bearing housing. Install the bearing housing guide pins and slip the housing over the pins. Insert a long snug fitting rod through the seal gas port of the bearing housing into the inlet port of the A-4 seal sleeve. Shift the A-4 seal sleeve until the ports line up and the rod goes in full depth. This ensures the correct roll pin position. If the compressor has proximity probes, the protective sleeve must be installed in the bearing housing before assembly.
- 9. Slide the bearing housing in full depth, install the cap screws and torque to the special value required by the compressor drawing. Replace all oil lines, fittings, and gas lines. Maintain cleanliness during reassembly.
  - 10. Install the shaft bearing and shaft seal as previously described.

#### REMOVING OIL PUMP ASSEMBLY, THRUST BEARING AND DISCHARGE END JOURNAL BEARING

The oil pump, thrust bearings (forward and reverse) and the reservoir end journal bearing are accessible through the oil reservoir without removing the casing top half.

If it becomes necessary to replace any of these parts, refer to Figs. 20, 21, 22 and 23 and proceed as follows:

1. Transfer the refrigerant charge. (See Preparation for Servicing.) Follow guidelines to isolate machine from operating.
2. De-energize the oil heaters.
3. Loosen compressor drive coupling 12-point nut and remove the driven coupling disk.
4. Drain the oil from the sump and remove the oil sump cover.
5. Loosen the 90 degree elbow (54) and remove the vertical jet pump body (55). It may be necessary to loosen the jet nozzle (57) to disengage the body from the elbow.



***The current style oil pump housing is a two piece design (see inset Fig. 21). When the screws are removed, only the oil pump housing cover, the reverse thrust bearing, and a 1/64" gasket will come loose. Remove the two recessed cap screws that position the pump housing body and volute ring. If proximity probes are used, they must be backed out a couple of turns before working on the oil pump housing. The volute seal ring (42) is secured in the pump housing by means of a retaining ring (43) and is located with an insert pin (45). The reverse thrust bearing is located by means of an insert pin (45). After removing the oil pump housing, record the total number, position, and thickness of all gaskets.***

6. Remove two cap screws (51) from the oil pump housing. Install guide pins and remove remaining cap screws. Pull oil pump housing assembly.



***The oil pump and thrust bearing position the rotor shaft axially. With the oil pump removed, the rotor can shift forward and damage the shaft seal. Damage can be avoided by backing off the seal cover bolts.***

**TABLE 12 - CLEARANCES (INCHES) TYPICAL**

COMPRESSOR SIZE	THRUST BEARING AXIAL CLEARANCE	MAXIMUM OIL PUMP RUNOUT (T.I.R.)		OIL SEAL DIAMETRAL CLEARANCE	
		FACE	RIM	DRIVE END	RESERVOIR END
25"	.008 - .012	.0005	.0005	.002 - .005	.001 - .004
26"	.008 - .012	.0007	.0006	.002 - .005	.002 - .007
38"	.010 - .014	.0010	.0008	.003 - .006	.002 - .007
55"	.013 - .017	.0013	.001	.004 - .008	.002 - .007

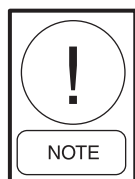
COMPRESSOR SIZE	VOLUTE SEAL DIAMETRAL CLEARANCE	*BALANCE PISTON SEAL DIAMETRAL CLEARANCE	SHAFT LABYRINTH DIAMETRAL CLEARANCE	IMPELLER INLET LABYRINTH DIAMETRAL CLEARANCE	RESERVOIR END MAIN BEARING DIAMETRAL CLEARANCE (SMALL END, TAPER BORE)
25"	.004 - .007	*	.011 - .014	.0112 - .017	.001 - .003
26"	.003 - .009	*	.014 - .024	.020 - .025	.002 - .005
38"	.003 - .009	*	.020 - .030	.030 - .037	.002 - .005
55"	.004 - .011	*	.020 - .039	.044 - .053	.0025 - .0055

COUPLING SIZE	COMPRESSOR SIZE	SUCTION END BEARING LENGTH	DIAMETRAL CLEARANCE SHAFT TO BEARING (SMALL END, TAPERBORE)	DIAMETRAL CLEARANCE SHAFT TO BEARING TAPERLAND	DIAMETRAL CLEARANCE BEARING TO BEARING HOUSING
1"	25"	1-9/16"	.0015 - .0035	.0015 - .0035	.0005 - .0025
1-1/4"	25" & 26"	1-11/16"	.002 - .004	.002 - .004	.0005 - .0025
1-1/2"	25", 26" & 38"	2-3/8"	.002 - .004	.003 - .005	.001 - .003
1-7/8"	26", 38" & 55"	3-1/4"	.0025 - .0045	.003 - .005	.001 - .003
2-1/2"	38" & 55"	4-7/32"	.003 - .005	.004 - .006	.0015 - .005
3"	38" & 55"	5-1/4"	.004 - .006	.005 - .007	.002 - .0055
3-3/4"	55"	6"	.006 - .008	.006 - .008	.002 - .0055

**\*NOTE:**

Assembly clearance is dependent on rotational speed. Some high speed compressors require greater clearance. Aluminum seals only see compressor application data sheet for other materials.

- Remove 12-point cap screw (46) and remove the centrifugal oil pump (41).
- Remove the thrust bearing or combination thrust and journal bearing. If combination bearing is used, raise rotor shaft to ease removal.



*Separable journal bearings are positioned away from the thrust bearing with a roll pin or a ventilated spacer.*

- Separate thrust bearings come in two styles, hydrostatic flat aluminum and tilting pad with Babbitt metal shoes. The hydrostatic thrust is sometimes incorporated with the discharge end shaft bearing as a single unit. Both styles of aluminum thrust bearings are used with an oil pump that has pockets on the forward thrust face. These pockets act

**TABLE 13 – SCREW SIZES FOR PULLING DRIVE END JOURNAL BEARING**

COMPRESSOR	COUPLING SIZE (INCHES)	SCREW SIZE
226	1-1/2	10-24
238	1-7/8	10-24
	2-1/2	1/4-20
	3	3/8-16
255	3	3/8-16
	3-3/4	3/8-16

as oil pumps, circulating oil across the thrust face and out through small holes, which develop oil pressure greater than the compressor main oil pressure. Oil off the thrust is circulated through the oil coolers and returned to the sump via the jet pump nozzle.

The aluminum thrust bearing, oil pump, and jet pump assembly are dedicated items and must be used together.

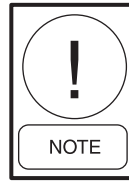
The tilting pad thrust bearing is used with an oil pump that has a flat forward thrust face and is not designed to pump oil. Thrust oil is still circulated through the oil coolers, but at a lower pressure, equal to or somewhat lower than main oil pressure. Thrust oil pressure is a function of oil pump design, thrust bearing design, and compressor RPM.

The tilting pad thrust bearing, oil pump, and jet pump assembly are also dedicated items and must be used as an assembly.

All thrust bearings are located in position with a roll pin to prevent rotation within the bearing recess.

The reverse thrust bearing is a flat aluminum disk, or tilting pad type bearing, that doesn't contact the oil pump reverse face during normal operation. It acts as a "bumper" to limit rotor end float should the rotor move to the rear for any reason

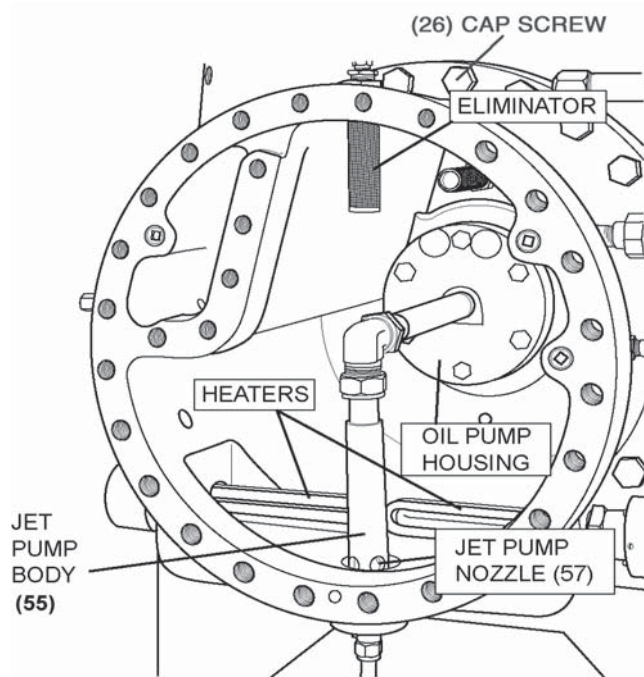
It's positioned in the oil pump housing and is held in place with a roll pin to prevent rotation within the housing.



***The discharge end journal bearings come in two styles, taper bore and taper land. (See Removing Suction End Journal Bearing for explanation.) The same restrictions on roll pin location apply if a bearing must be repositioned radially. Refer to section on Suction End Journal Bearings for description.***

**4**

10. Screw puller rods into the discharge end main bearing and pull it off the rotor journal. If the main bearing is separate from the thrust bearing, it is positioned axially in the bearing recess by a roll pin inserted in the bearing flange that extends against the thrust bearing or a ventilated spacer disk between them. The shaft bearing is positioned radially by a roll pin fitted into a slot in the bearing flange at 12 o'clock.
11. After disassembly, inspect all parts for wear or damage.



LD07335

**FIG. 20 – OIL RESERVOIR**

**TABLE 14 – GENERAL BOLT TORQUES**

BOLT SIZE (INCHES)	BOLT TORQUE (FOOT POUNDS)
1/4	10
5/16	20
3/8	35
1/2	75
5/8	155
3/4	260
7/8	410
1	600
1 -1/8	860
1 -1/4	1200

**NOTE:**

Torque values **should not** be substituted for specific drawing values or be used for coupling bolts. Refer to Coupling Instruction. (Form 160.71-NL)

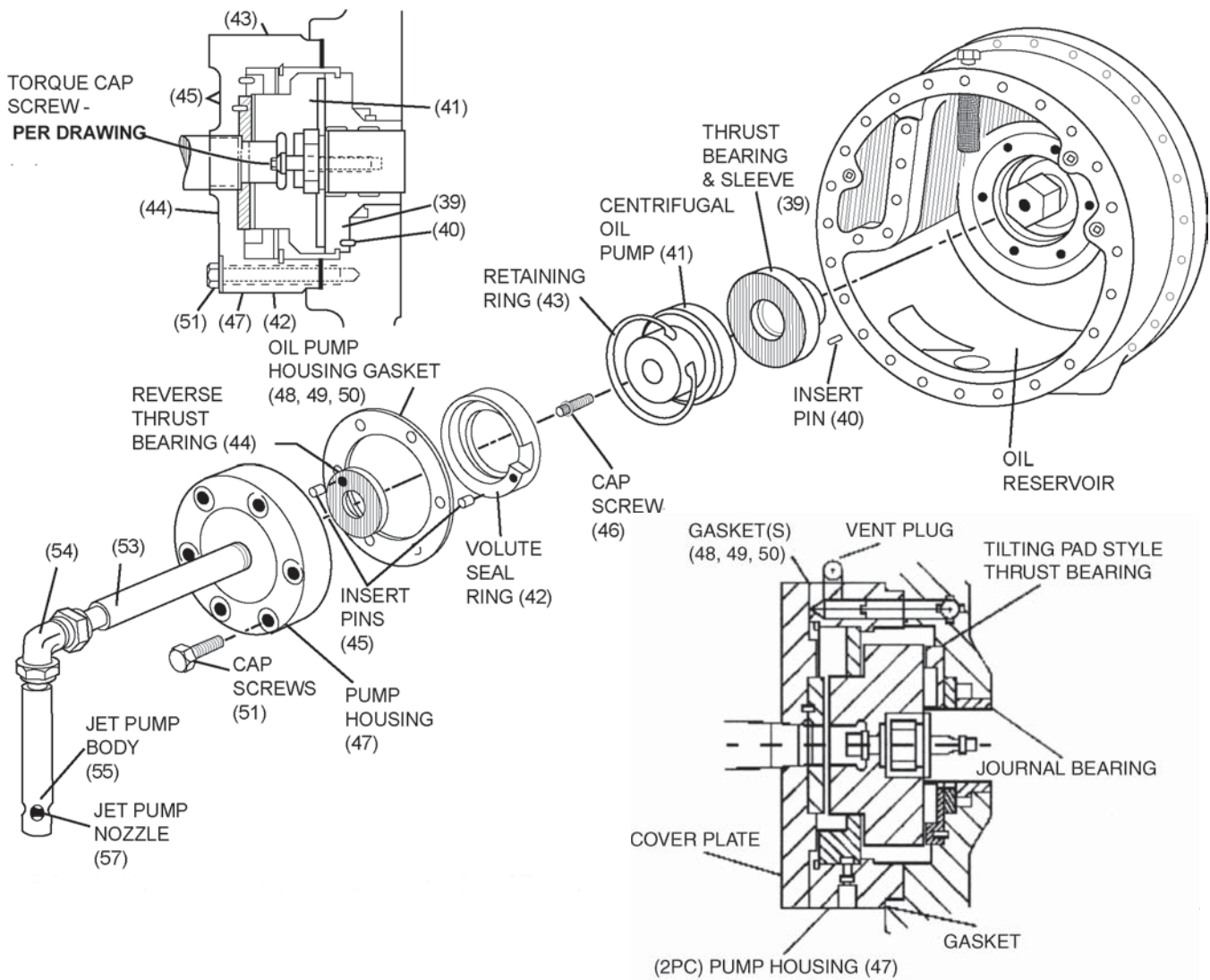
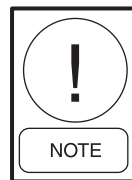


FIG. 21 – DISCHARGE END BEARING AND OIL PUMP ASSEMBLY, EXPLODED VIEW

**REPLACING OIL PUMP ASSEMBLY, THRUST BEARING AND DISCHARGE END JOURNAL BEARING**

If the discharge end shaft and thrust bearings are intact, and only show normal wear or slight scoring, it may not be necessary to flush the complete lubrication system. Should the bearings show signs of breakdown with metal particles distributed through the lubrication system oil galleries, then oil lines should be flushed and cleaned. Thrust oil is not typically filtered and bearing material may have been carried into the oil cooler.

The compressor sump has three plugs screwed into the outboard end that seal access holes drilled to construct the internal oil galleries. It may be necessary to pull these plugs, remove the external oil piping, and flush the oil galleries. After cleaning replace the plugs using an oil or paste sealant. Do not use teflon tape.



*Some external oil lines are screwed directly into the sump with nipples and fittings. When replacing the parts after flushing, use only approved sealants (refer to piping prints). Any leaks discovered after reassembly are difficult to correct. Inspect and clean all check valves. Be aware that some thread sealants will cause check valves to seize and fail to open properly.*

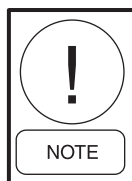
1. Inspect the discharge end shaft journal, thrust bearings and oil pump. Clean the shaft journal bearing as explained for suction end journal (See Removing Suction End Journal Bearing). Do not use abrasives.
2. When replacing the discharge end shaft bearing, position the rotor so the shaft hex flats are horizontal.



Be sure the axial positioning roll pin is in the discharge end shaft bearing and screw the pulling rods into the bearing. After coating the shaft journal and the bearing ID with Molycote and oil, carefully slide the bearing as far over the rotor shaft as it will go.

If a helper is available use a fulcrum and pry bar under the rotor hex flat to raise the rotor slightly while pushing the bearing into final position. On large units, two oil pump housing bolts can be screwed into the bottom holes in the sump face with a strong back across them and a screw jack used to raise the rotor. It is absolutely essential for the bearing to slip into place easily by hand. Do not use force to position the bearing.

3. Contrary to appearances, the oil pump does not sit against the end of the rotor. The oil pump seats against the shaft shoulder at the end of the journal surface (See Fig. 21). This shoulder must be absolutely perpendicular to the shaft axis or the oil pump will wobble. Dirt or other irregularities will also offset the pump.



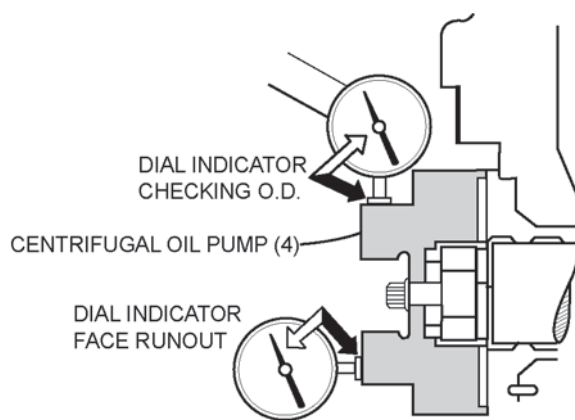
***The oil pump thrust face is an extremely smooth lapped surface. In order to hold pump securely in place after bolt-up, do not allow any lubricant on this area during assembly.***

4. Set the oil pump on the shaft, screw the new clamping bolt finger tight and turn the oil pump opposite to the direction of the shaft rotation until it sits against the shaft hex flat. This assures positive drive without the possibility of slippage. Snug the clamping bolt gently with a socket wrench.
5.
  - A. Set up a dial indicator capable of reading to 0.0005" on the rim of the large O.D. to check oil pump run-out. Use a magnetic base or screw an oil pump housing bolt into the sump. Turn the pump and rotor by the clamping bolt using a long extension.
  - B. Using a soft hammer or brass drift, center the pump to within the following specifications:

25"	.0005"
26"	.0006"
38"	.0008"
55"	.001"

The above values are max. allowable. Try to get within .0003". If the dimension cannot be achieved, remove the pump, recheck for burrs or dirt, rotate the pump 180° and repeat steps 4 and 5.

- C. Reset the indicator to read the reverse thrust face of the pump. Be careful the grooves and relief areas don't upset the indicator. A large diameter "foot" may be easier to use while taking this measurement.



LD07338

**FIG. 22 – CHECKING ALIGNMENT OF OIL PUMP**

- D. Tighten the oil pump clamping screw to the correct torque value. Refer to the compressor drawing for the torque value.
- E. Recheck the alignment of the pump. If it has shifted, loosen the clamping screw and repeat steps A through D.
6.
  - A. Slide the volute seal ring over the oil pump and check the diameter clearance with a feeler gauge (See Fig. 21). If the volute is acceptable, (See Table 12) position it over the locating pin in the oil pump housing and lock it in place with the snap ring.
  - B. Install the reverse thrust bearing over the locating pin.
  - C. Install the pump guide pins and position the required amount of pump gaskets over the pins. Coat all bearing and pump surfaces with Molycote and oil. Slide the oil pump housing into position. If you have the two piece oil pump housing, snug the two locating bolts and recheck the volute radial clearance. Center if required. Torque bolts and install the pump housing cover. Tighten bolts to approximately

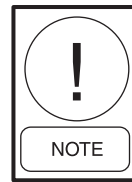
- 1/2 value. With the one piece cover just slide it over the pins and torque to approximately 1/2 value.
- After positioning the oil pump housing, check the axial clearance of the rotor. Set up a dial indicator on the compressor shaft to read to a reference point. Shift the rotor axially to the full extent, forward and reverse. The difference is the axial thrust clearance (See Fig. 22). Add or remove pump housing gaskets as necessary to achieve axial clearance within specifications. When the axial spacing is acceptable, torque the pump housing bolts to full value and recheck the axial clearance. Readjust if required.
  - Before installing the oil jet pump be sure the nozzle is free of dirt and the jet pump body isn't damaged. Check to insure all the 90 degree elbow clamping nuts are tight after the jet body rests on the nozzle bolted solidly into place.

#### REMOVING DISCHARGE END SEAL RING AND BALANCE PISTON SEAL RING (REFER TO FIGS. 23, 24 AND 25, AND TABLE 14)

If it becomes necessary to replace the discharge end seal ring or the balance piston seal ring, the oil reservoir housing must be removed.

Proceed as follows:

- Refer to Removing Oil Pump, Thrust Bearings, and Oil Reservoir End Journal Bearing.
- Remove all oil tubing (piping) and electrical connections attached to the reservoir.
- Remove cap screws from the flange holding the oil reservoir in place. Insert guide pins in the holes. Install a cardboard tube around the shaft, or if equipped with probes, install the protective sleeve.
- Insert oil reservoir guide pins and remove cap screws (Fig. 20) which secure the oil reservoir housing to the compressor casing.
- Support the weight of the oil reservoir from a chain hoist. Use jacking screws through the oil reservoir flange and carefully ease the oil reservoir out of the compressor casing. The seal ring, housing (36) is bolted to the back of the oil reservoir. A piston ring (31) is used to seal between the balance piston space and the compressor discharge and is located in the oil reservoir.



***It may be necessary to loosen several bolts (6-8) back to the compressor split line to minimize interference of the casing to the oil reservoir (or PRV housing).***

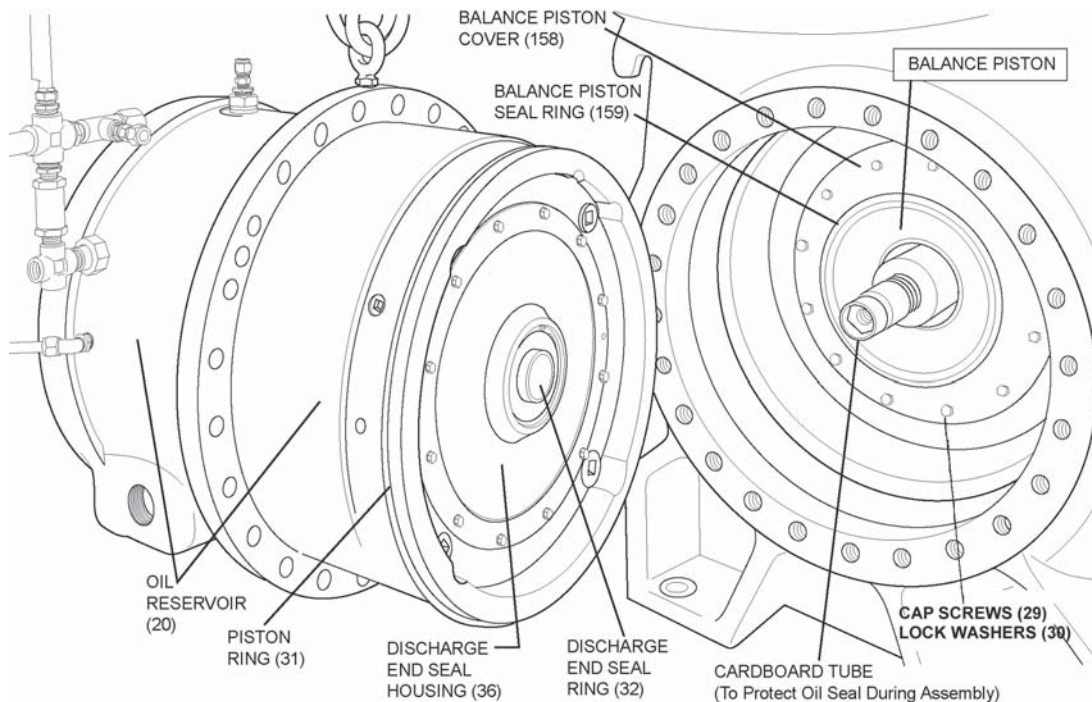
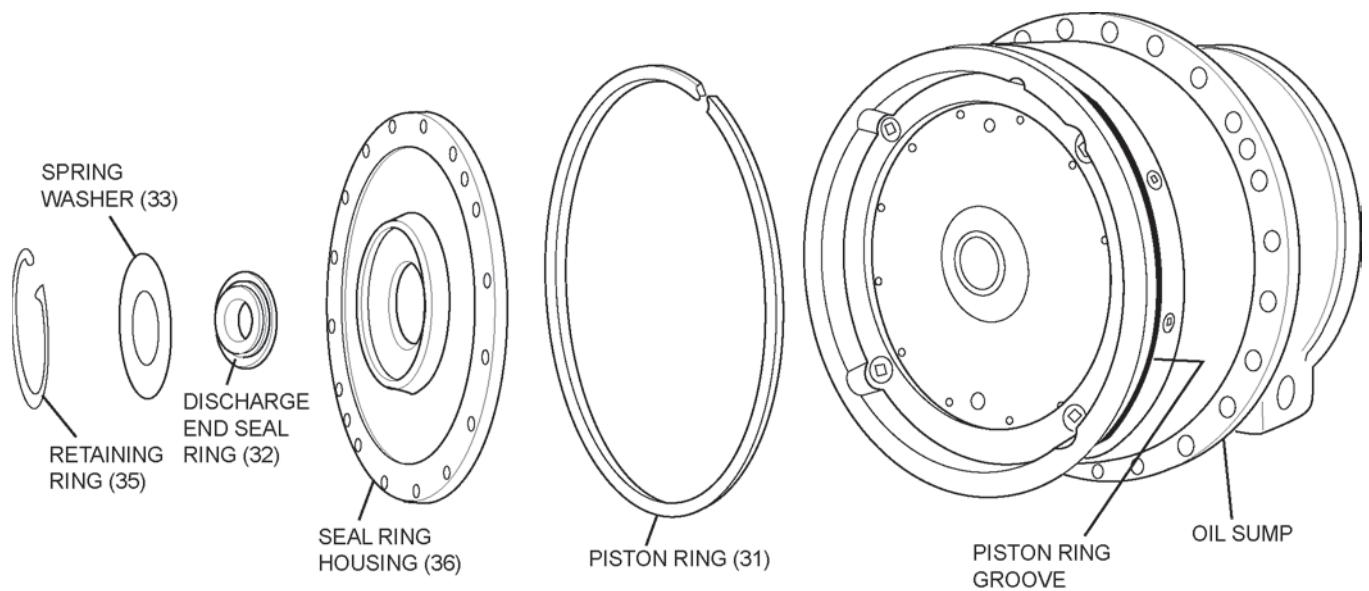


FIG. 23 – REMOVING THE OIL RESERVOIR

LD07339



**FIG. 24 – EXPLODED VIEW, OIL RESERVOIR AND OIL SEAL ASSEMBLY**

LD07340

Screw a short stud into one of the lower holes in the oil sump face. Slip a piece of pipe over it to obtain some leverage so you can maneuver and level the housing as you ease it out.

- The retaining ring (35), spring washer (33), models 226 and 238, universal spring (34), model 255, and seal ring (32) can now be removed. Note correct orientation of seal relative to the step faces. If installed incorrectly, severe oil loss can occur.



***If the seal is assembled incorrectly severe oil loss can result.***

A-4 seal ring assemblies are retained by a bolted seal cover and gaskets. Again note the seal configuration, the inboard and outboard seal components may not be the same. If the compressor internal condition is unusually dirty, with sludge and dirt, remove the seal ring housing and clean all surfaces.

- The balance piston cover (158) houses the balance piston seal ring (32). The entire assembly is fastened to the last stage diffuser by means of cap screws (See Fig. 23). Remove the cap screws (29), lockwashers (30), and pull the balance piston cover (158) through the end of the compressor casing. The seal ring (159) and spring washer (160) can now be pulled off the balance piston (Fig. 25 shows an exploded view of the balance piston seal assembly).

Observe the pin extending through the spring washer that prevents the seal from turning. Early model compressors did not have this pin. The addition of an anti-rotation pin is recommended when service provides access. This may require procurement of a new last stage exit plate if not equipped with a “windage” baffle.



***Some balance pistons are integral with the high stage wheel and some are bolted on. If the balance piston is bolted on do not remove it in the field. It may cause unbalance in the rotor after reinstallation.***

- Inspect all parts. Oil seal rings should always be replaced. If the balance piston seal ring grooves show no wear and the clearances are acceptable, reuse the seal ring. (Note: there are numerous diameters and clearances for each compressor size. Seal material may vary with the application and clearance is a function of seal material and compressor speed.)

#### **REPLACING DISCHARGE END SEAL RING AND BALANCE PISTON SEAL RING**

- Inspect new seal parts for nicks and burrs. Remove any sharp edges. Carefully assemble seal components. With A-1 seals be sure of correct orientation relative to the spring washer. Snap the retainer into place.

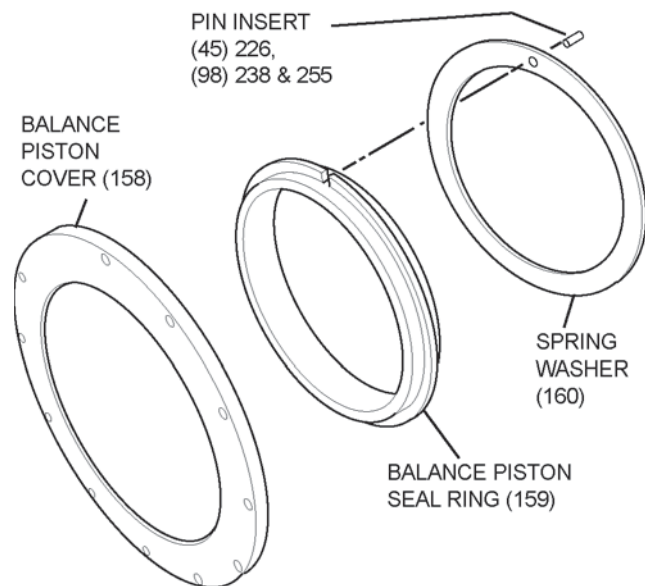
- A-4 Seal parts may be supplied as components or assemblies. If field assembly is required **refer to compressor print** for instructions. Fit seal into the seal ring housing and install seal ring cover with gasket.
- Coat balance piston O.D. and balance piston seal ring ID with Molycote and oil. Slide the spring washer over the insert pin and position the seal ring in the recess. Note orientation of the seal ring step face, be sure it's correct (See Figs. 25). Bolt up the balance piston seal cover. Use a feeler gauge to set clearance 75% open at the top, 25% on bottom, and equal on the sides. This allows for rotor sag when the sump is removed and the rotor is resting on the labyrinth seals.
  - Check that the sump piston ring is not stuck or broken. Lubricate the O.D. of the sump housing and piston ring. Some heavy grease may help keep the piston ring centered. Coat the ID of the piston ring housing with Molycote and oil. Pad the rotor hex to prevent seal damage. Coat the seal ID and the rotor shaft O.D. with Molycote and oil. If the sump gasket requires replacement be sure new gasket is the same thickness. Remove all jack bolts from the sump flange. Use the protective sleeve if compressor is equipped with probes. Failure to use the sleeve will result in damage to probes.
  - Position sump over guide pins and ease into the compressor until the sump piston ring enters the housing. Use studs and nuts to pull the sump evenly into compressor until the cap screws can be started. Keep the sump as square as possible. Do not force, or damage to the piston ring may result.
  - Relax the lifting rigging. After the sump has been seated and all bolts torqued, install the discharge end bearing. If the suction end bearing is in place, the rotor should turn easily. Install the thrust bearing and oil pump assembly. Replace all oil lines and fittings (See Replacing Oil Pump Assembly, Thrust Bearing and Discharge End Journal Bearing).

#### REMOVING PRE-ROTATION VANE ASSEMBLY

If it becomes necessary to remove the Pre-rotation Vane housing (154), refer to Figs. 26 and Foldout Fig. 4B.

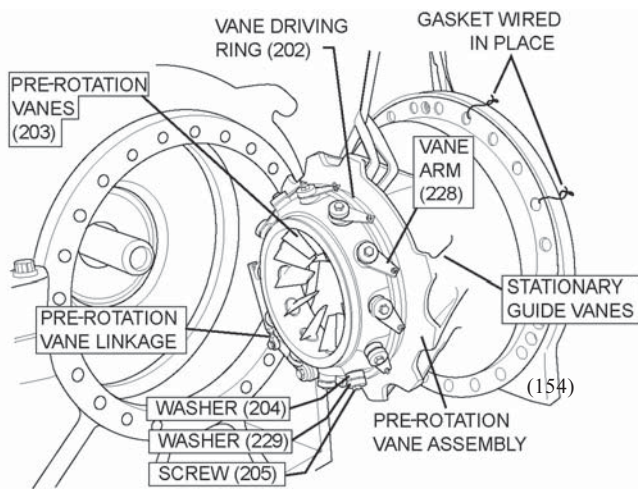
Proceed as follows:

- Follow instructions outlined in Preparation for Service. Lockout/tagout main motor drive. Transfer refrigerant from unit to pumpout receiver. (Refer to Form 160.71-NM3 if a pumpout receiver is available.)
- De-energize oil heaters.
- Drain oil from the seal return cavity in the oil reservoir.
- Remove the PRV actuator and mounting bracket.
- Remove oil tubing from the bearing housing.
- Remove the coupling guard, driven coupling disk, drive coupling disk, shaft seal compressor drive shaft, bearing, bearing housing, PRV sleeve, and seal ring(s).
- Remove the internal vent tube (67) between the casing and the PRV assembly (Refer to Foldout Fig. 4B). The vent line adapter must be removed to expose the equalizer tube.
- Remove the hex head cap screws (26) securing the pre-rotation vane housing to the compressor casing. Use screws as jack bolts to loosen the PRV assembly. Try to keep from breaking the gasket.



LD07341

**FIG. 25 – EXPLODED VIEW, BALANCE PISTON SEAL ASSEMBLY**



LD07342

**FIG. 26 – REMOVING THE PRE-ROTATION VANE ASSEMBLY**

9. Manually close the pre-rotation vanes to permit the linkage to pass through the opening in the casing. (Rotate Model size 26 vane housing two bolt holes clockwise to clear linkage.) Install two guide pins.
10. Slowly ease the PRV housing out until an appropriate lifting device can be rigged between the stationary inlet vanes and a pin or bolt screwed into the top jack bolt hole. Take up the weight and remove the guide pins. Use care to not bump the rotor journal as the PRV housing is removed. Place the PRV housing on suitable blocks.

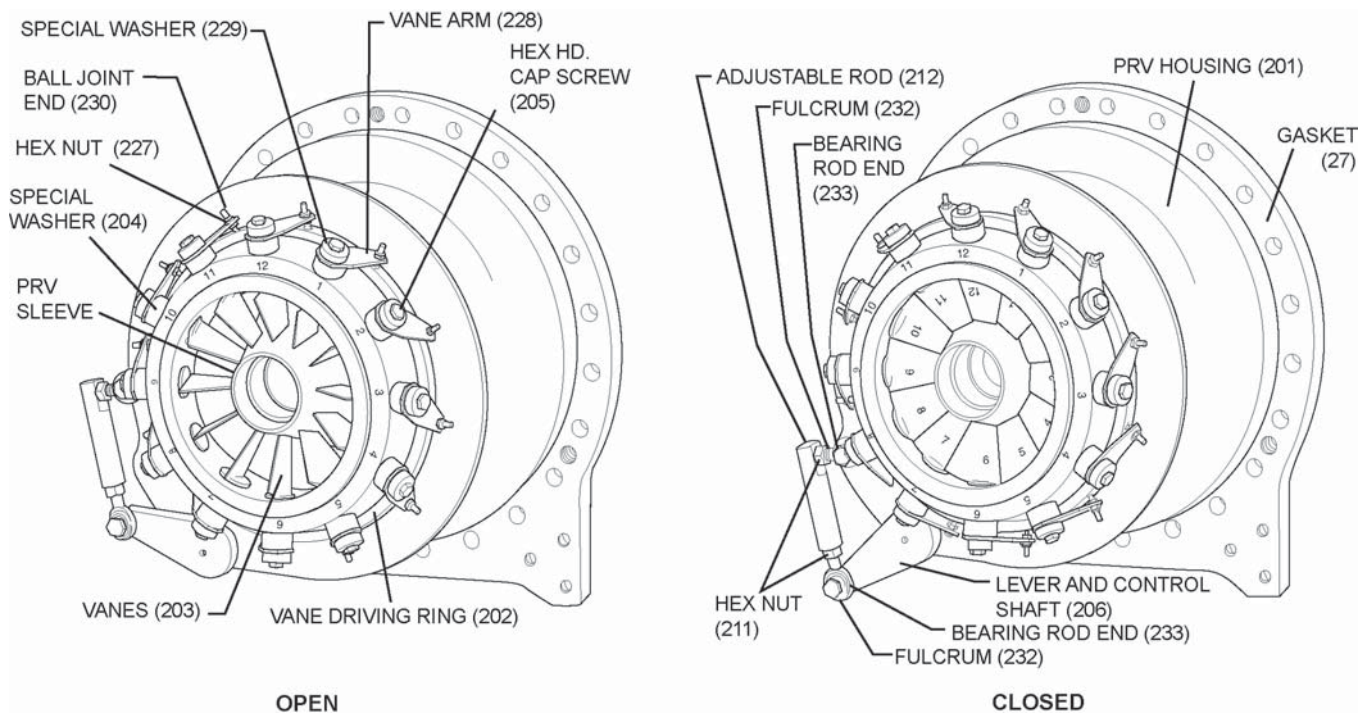
## REMOVING PRE-ROTATION VANES

The pre-rotation vane assembly must be removed from the compressor. The individual vanes seldom require service. If foreign material has damaged the vanes or system dirt and corrosion have locked the vanes, vane disassembly may be required. Vanes are actuated by a rotating vane driving ring (202) through individual arms (228). To remove the vanes refer to Figs. 26, 27 and 28. proceed as follows:

1. Remove the cap screw (205) securing the washer (229), vane arm (228), and washer (204), to the pre-rotation vane.
2. Remove the arm, two washers, and vane (203) by pulling vane toward the inside of the vane housing.

## REPLACING PRE-ROTATION VANES

Individual vanes have an airfoil section and overlap slightly when in the closed position. Ensure the overlap is such that when facing the PRV housing inlet, counter clockwise rotation of the control shaft (206) will open the vanes, and clockwise will close them. All vanes must move in unison and the heavy end of the airfoil must point into the gas stream. Check the ballstud and special fulcrum joints for wear and replace if required.



**FIG. 27 – PRV HOUSING ASSEMBLY (OPEN AND CLOSED VANES)**

LD07343



***If work is being performed on only one or two vanes they may be held with an appropriate wrench, on the heavy part of the vane, as they are aligned and the clamping screws are properly torqued. A clamping fixture (step 4) may be constructed if the entire vane assembly requires alignment and tightening.***

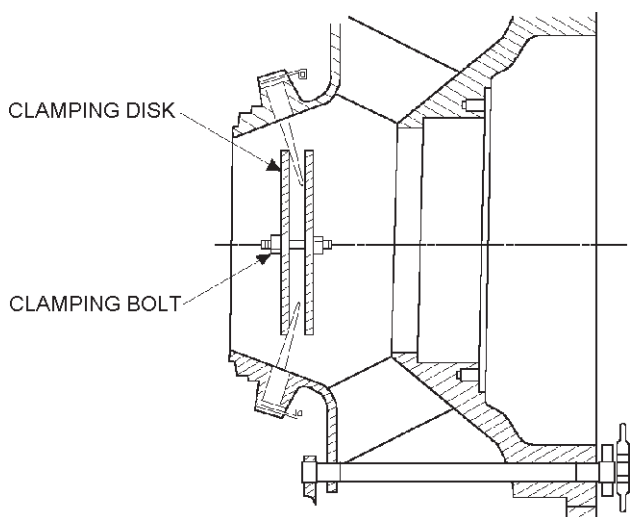
1. Lubricate the vane and housing vane hole with Molycoté and oil.
2. Carefully place vane in PRV housing.



***Each vane and matching housing vane hole are stamped with a number. Make sure all numbers match. The vanes are originally ground to provide for a minimal clearance paddle to paddle and to the housing. Replacement vanes will require some "fitting" to achieve proper clearance.***

***Shimming may also be required to adjust the ball studs to drive ring. When properly adjusted 5 - 25 pounds of force will be required to rotate the completed assembly.***

3. Ensure both sides of washer (204), vane arm (228), and lower surface of washer (229) are clean, dry, and free of Molycoté and oil. Place washer (204), vane arm (228), and washer (229) over the vane stem. Center all holes and insert cap screw (205) through the assembly. Only tighten cap screw until snug.
4. Refer to Fig. 28 for use of vane clamping fixture. 3/4" plywood can be used as clamping fixture ma-



LD07344

FIG. 28 – VANE CLAMPING FIXTURE

terial. Align vanes, place clamping fixture disks in position, and tighten clamping bolt. Properly torque vane clamping screws and remove fixture. Make final individual vane adjustments as above.

## REMOVING CONTROL SHAFT AND CONTROL SHAFT COVER

The current design control shaft is a one piece shaft with the shaft lever welded to the inboard end. The older design, still in service on many machines, is of two piece construction and the lever arm is bolted on. Although some spares are still available for service, it is recommended that the new style shaft and cover be installed whenever the compressor is being overhauled. Some old style PRV covers control shaft covers were of solid construction, but all machines now use a shaft cover that has seal return oil circulating through internal passages. The circulating oil helps lubricate the control shaft O-rings and also warms the shaft cover to minimize frost buildup when running at temperatures below freezing. If a refrigerant or oil leak is detected around the control shaft cover, proceed as follows:

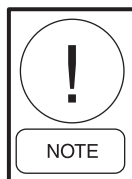
1. Pump down the system and remove the charge. Remove the seal oil lines from the control shaft cover.
2. Loosen the cap screws, lockwashers, and nuts holding the external lever. Remove the external lever assembly.
3. Remove the two cap screws and carefully pull the shaft cover off the control shaft. Remove gasket.
4. Inspect the control shaft O.D. and the shaft cover ID for corrosion or damage. Check the O-rings for excessive swelling or splits. Check the gasket for signs of damage. The earlier two piece shafts had a tongue and groove joint between the shaft sections that allowed the front part to be removed without opening the PRV housing. The outer portion of the control shaft had a rubber bushing vulcanized to it that formed a gas proof seal when clamped between the internal gasket and the PRV shaft cover. Check this bushing for splits or separation.

If the control shaft must be removed, the PRV housing must be removed. Refer to Removing the Pre-rotation Vane Assembly and proceed as follows:

1. Remove fulcrum screw (232) from rod end bearing (233), freeing the control shaft (206) internal lever.
2. Remove retaining ring (234) and pull control shaft and lever from the PRV housing. Remove control shaft thrust collar.

3. Replace the control shaft by reversing the two steps above. Use Molycote and oil between the thrust washer, control shaft, and PRV housing. When installing fulcrum screw (232), carefully put a drop of Loctite thread locker (Loctite 277) on the threads. Do not get Loctite on the bearing rod ball joint.

### Replacing Control Shaft Cover



***For the old style shaft with vulcanized rubber bonded bushing, set vanes to 50% open prior to torquing cover screws.***

1. Install new O-rings, (refer to compressor drawing) on the control shaft and place a new gasket in the PRV housing recess. Lubricate the control shaft and O-rings with Molypaste. Seat the shaft cover and torque the cover cap screws.
2. Verify that all shaft cover markings are in the same locations and that control shaft and vanes rotate freely.

### ADJUSTING THE PRV

After the PRV assembly has been reassembled the operation of the vanes should be checked.

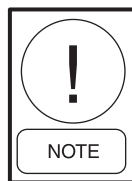
1. With the vanes in the closed position the insert pin pointer should be pointing to "C" on the shaft cover.
  - A. If the vanes are not closed with the insert pin pointer on "C", adjust the linkage.
  - B. All vanes should be closed, if not, loosen the hex head cap screw that holds the vane(s) in place. Move the vane until it is fully closed, then tighten and torque screws properly.
2. Use the lever to move the vanes to the open position "O" stamped on the PRV shaft cover. All vanes should be fully open. (Early 26" and 38" compressor have an "R" stamping on the cover.) With the lever move the pointer to "R", at this point the vanes should be approximately 20° beyond fully open position.
3. If all positions are not correct, readjust the vanes in the closed position and recheck as previously mentioned. Make sure the linkage is properly tightened and is moving freely.
4. PRV actuators (usually air operated Conomotors), come in two basic configurations; direct and reverse acting. Direct acting has the actuator shaft retracted at minimum actuating air. Reverse acting has it fully extended at minimum air. The external lever clamped

to the control shaft has two fulcrum points, upper and lower. Depending on how the actuator is mounted on the PRV housing, either style may be supplied. Some units are still supplied with the optional hand wheel and linkage for manual operation.

5. Set the vane indicator pin to the "C" mark with the vanes fully closed. Some applications may require the actuator stroke to hold the pin about 3/32" open at minimum actuating air. This will hold the vanes open slightly at all times and ease start-up. This will also increase the in rush demand on the driving hardware.

### REMOVING SHAFT AND IMPELLER LABYRINTH SEALS

Two piece labyrinth shaft seals (See Fig. 31) are located in the exit plate on the high pressure side of the diffuser to minimize gas leakage along the shaft. The first stage diffuser is equipped with a one piece impeller eye labyrinth seal to prevent the discharge gas of the first stage from leaking back into the inlet of the first stage wheel. Each successive stage impeller inlet eye seal is of two piece construction and is keyed into a matching groove in the diffuser inlet entrance plate. They are kept from rotating by means of a locating disk. (Fig. 4B, Item 74.) Install these disks in the notch during reassembly, because it is impossible to disassemble the diffuser if the seals should rotate. Some compressors may have up to eight stages, but additional stages all follow the same pattern of construction. If it becomes necessary to remove the top half of the compressor to replace the labyrinth seals or work on the rotor, refer to Figs. 29, 30, and 31 and proceed as follows:



***It may be necessary to loosen or back off on the compressor hold down bolts before removing the top half. Failure to do so may result in elevated cross-foot stresses which may cause problems during reassembly. The flat foot plane should be checked and bolts retorqued after reassembly has been completed.***

### Removing Top Half of Compressor Casing

Refer to Preparation for Service. Lockout/tagout main motor on driver. Remove unit charge and drain the oil. (See Refrigerant Transfer Unit and Pump Out Receiver, Form 160.71-NM3.) Make sure main and control power are OFF. Remove the compressor suction and discharge piping. Remove the oil piping and tubing. Remove the coupling guard and open the coupling. (Refer to Re-

moving Driven/Drive Coupling Disk). Remove the compressor shaft seal. (Refer to Removing the Shaft Seal). Remove the oil sump cover, the oil pump assembly and thrust bearings. (Refer to Removing Oil Pump Assembly). Although the drive shaft doesn't have to be removed to lift the casing top half, it may be easier to work if it is removed. (Refer to Removing Compressor Drive Shaft).

1. Read instruction Preparation for Service thoroughly.

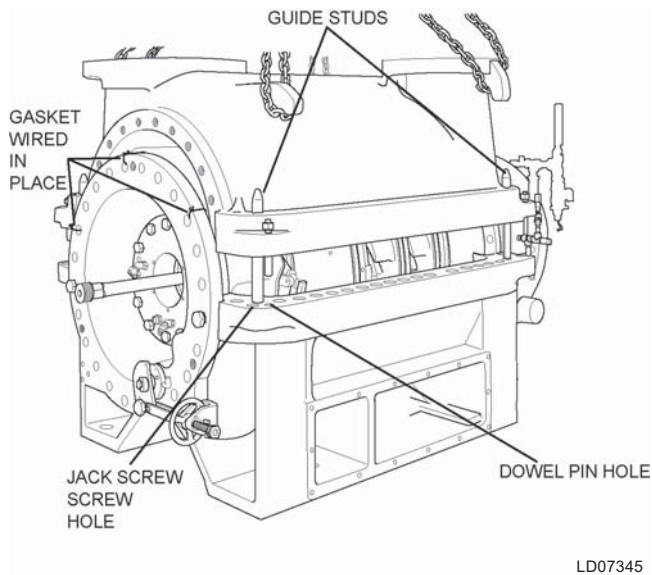
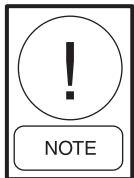


FIG. 29 – LIFTING TOP HALF OF COMPRESSOR CASING

2. Remove cap screws (26) that hold the PRV assembly and oil reservoir to top half of casing. Remove cap screws Fig. 4B, which secure horizontal joint the top half of the compressor casing to the bottom half of the casing. Loosen the remaining cap screws (26) in the PRV and oil sump flanges so that both can be pulled back approximately 1/8-1/4".

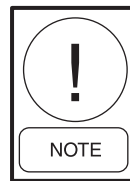


**Some model compressors have four cap screws assembled from the bottom half of casing to the top half. These screws must be removed to remove the top casing half.**

3. Remove the four casing flange dowel pins (115) and nuts (116).
4. Screw the four guide studs (shipped with the tools) into four of the holes from which the casing cap

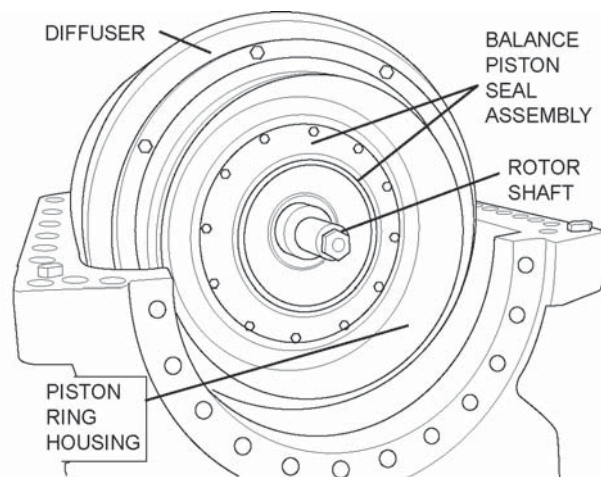
screws were removed – one stud near each corner. The purpose of guide studs is to insure that the casing is being lifted, or lowered, evenly to avoid damaging internal parts (See Fig. 29).

5. Using four of the cap screws (removed from the casing flange) as jack screws, turn the screws up into their tapped holes in each corner of the lower casing flange until the ends of the screws bear against the underside of the top casing flange. Normally, four jack screw holes are furnished with two pry positions provided at the corner nearest the suction connection and discharge connection.
6. Carefully break the horizontal joint by turning the jack screws evenly about 1/4 a turn at a time until the top half is free. Use a knife or flat tool to separate the top flange from the gasket (1). Make sure a new gasket (1) is available for replacement.



**Remove the vent tube between the casting and PRV housing. Before attempting to lift the top 1/2 of the compressor.**

7. With a chain hoist rigged to the lifting hooks cast into the upper casing half, check the level and carefully lift the casing vertically until it is clear of the guide studs (See Fig. 29). Place the top casing on blocks and remove the jack screws from the lower casing flange.



LD07346

FIG. 30 – AFTER LIFTING TOP HALF OF COMPRESSOR CASING WITH SUMP HOUSING REMOVED



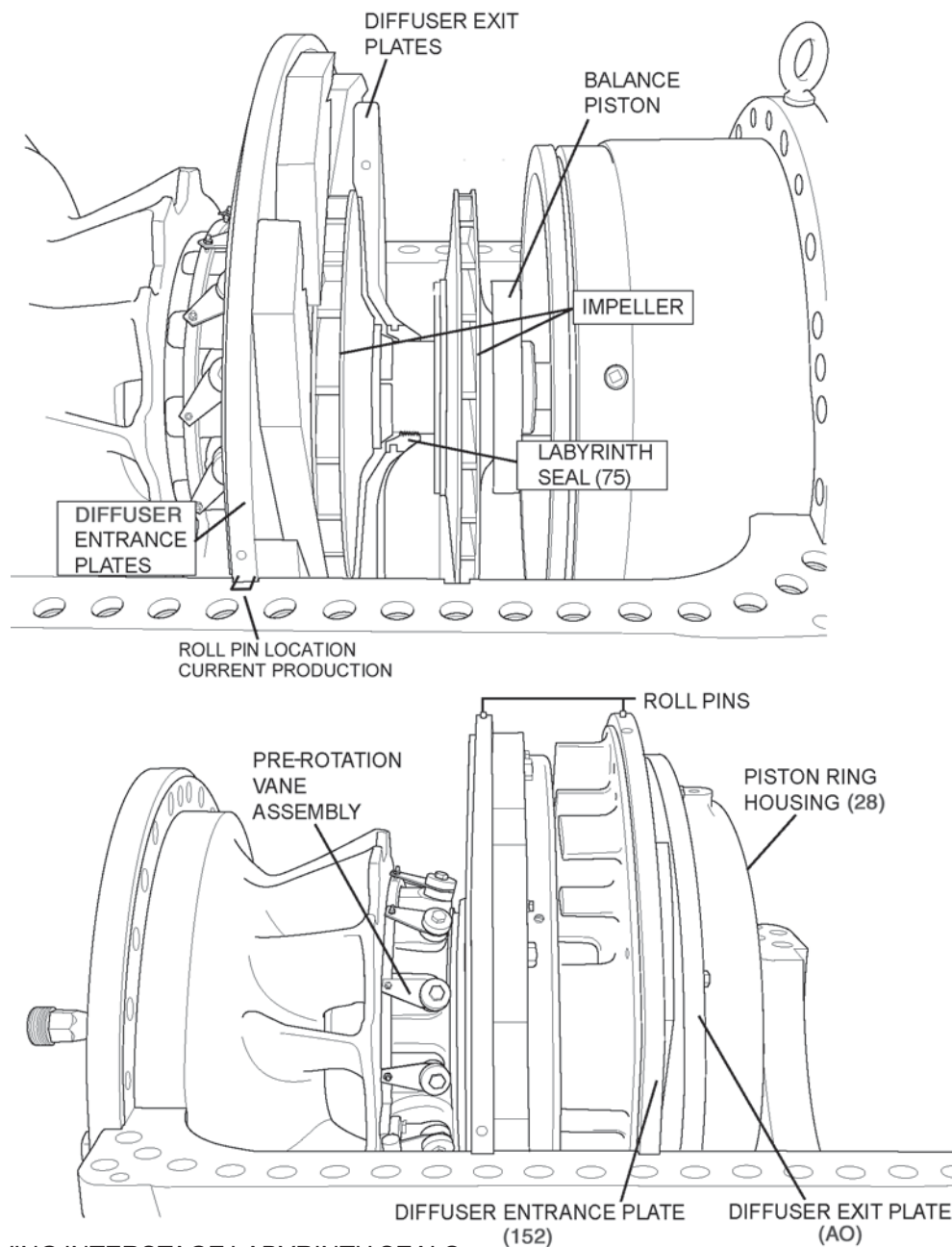


FIG. 31 – REMOVING INTERSTAGE LABYRINTH SEALS

LD07347

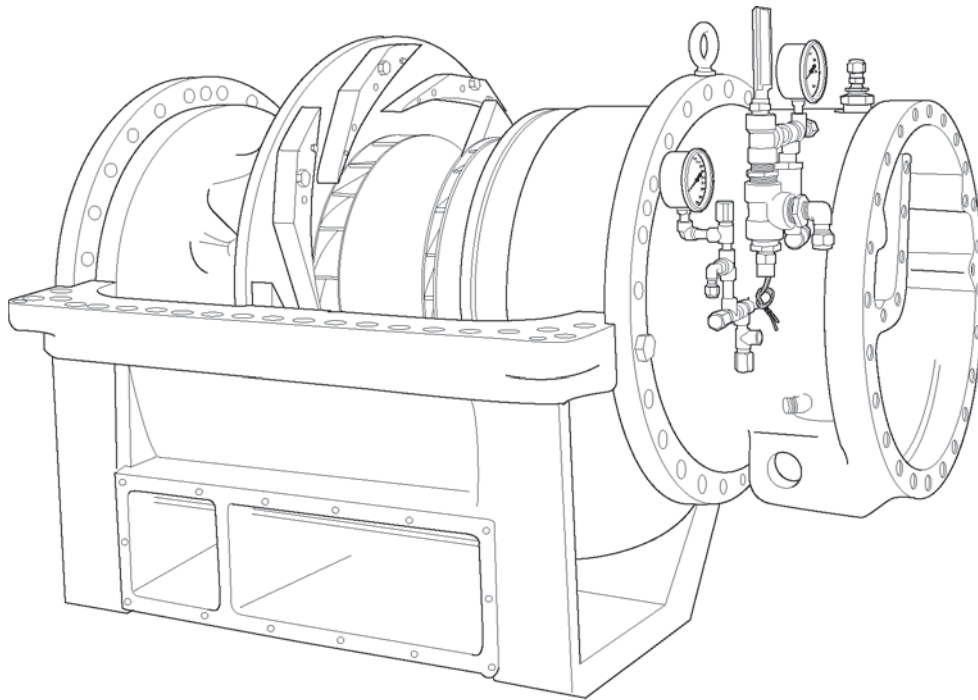
### REMOVING LABYRINTH SEALS AND COMPRESSOR ROTOR

1. Remove the oil reservoir and balance piston ring. (See Removing the Discharge End Seal Ring and Balance Piston Seal). (See Figs. 23 & 24).
2. Remove the piston ring housing (28) from the high stage diffuser and the exit vane plate (190) (Fig. 31). Compressors with 8 vane diffuser and more than two stages often have internal equalizer tubes. These tubes will be apparent when the last stage exit plate has been removed. The tubes must be removed before the diffusers can be disassembled.



***Be careful not to damage cast iron seals when removing the balance piston vent tubes. Check the tubes carefully for any evidence of damage.***

3. Reinstall the oil reservoir and the PRV housing snug to the casing. Hold each one with three cap screws (26). Slack off rigging before snugging cap screws. Tighten snugly. Install assembly bearings to allow rotor to freely rotate.
4. The diffusers of various compressor models vary in construction details, but each one essentially con-



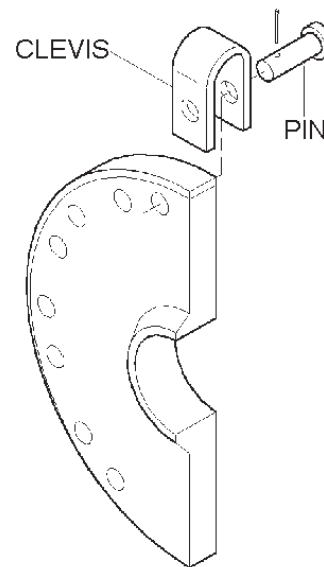
LD07348

**FIG. 32 – DIFFUSERS REMOVED**

sists of a vane entrance plate and a vane exit plate. The high stage vane entrance plate is split in half across its diameter to facilitate removal and installation of the inlet labyrinth seal (156). The vane exit plate contains the shaft labyrinth seal (75).

Beginning with the last stage diffuser disassemble as follows:

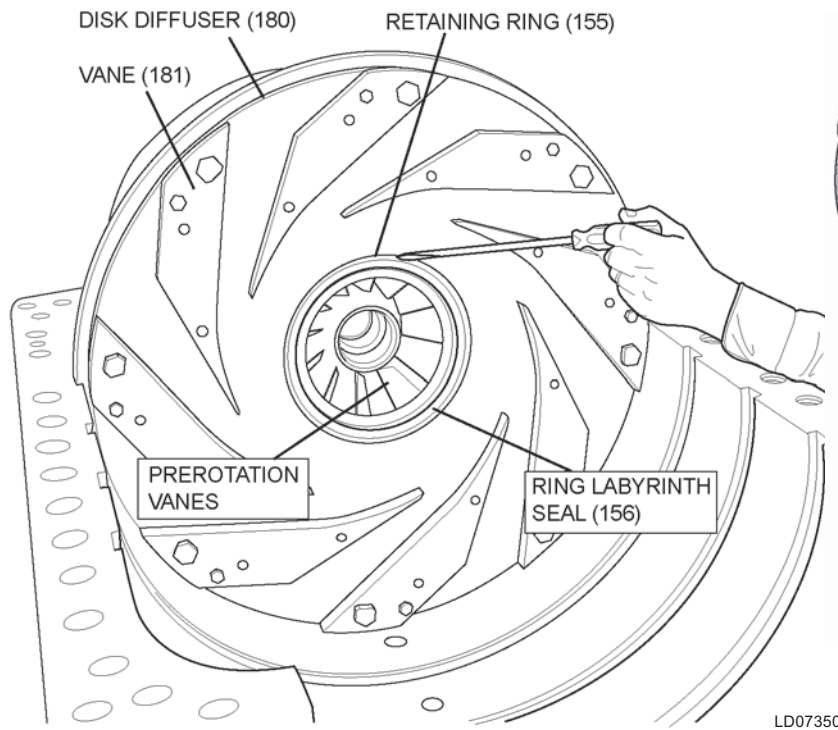
- A. Remove the top half of the vane entrance plate (152) and the retaining disk (74) from the lower half. Use a pry bar or studs screwed into the tapped holes in the rim of the lower half of the diffuser to rotate it up on the impeller until you can screw an eye bolt into it and lift it off. Be careful, the diffuser has some sharp points on it and if it sinks back into the casing it will come up the other side and may cause injury or damage other parts. If the compressor has more than two stages, you must rotate the next lower stage diffuser until the exit plate splitline is horizontal. Remove the screws in the top half and use an eye bolt to remove and set the top half down. Remove the labyrinth seals. Make up some studs about twice as long as the screws removed, with a short 90° bend on one end. Remove two screws from the lower half and screw in the studs. Remove the rest of the screws and slide the lower half out on the studs. Screw some eye bolts into the holes in the upper surface of the exit plate and rig a short sling.



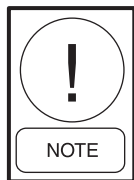
LD07349

**FIG. 33 – EXIT PLATE REMOVAL**

As you take up the weight of the exit plate, half, remove the guide studs. Lower the exit plate half down into the casing. Procure a “U” shaped clip with cross drilled holes in the open ends and slip it over the top bolt hole in the exit plate. Slip a pin through the clip to make a clevis. (See Fig. 33). Hook a line to the clevis and carefully lift the exit plate half out of the casing. Don't hit the rotor shaft.

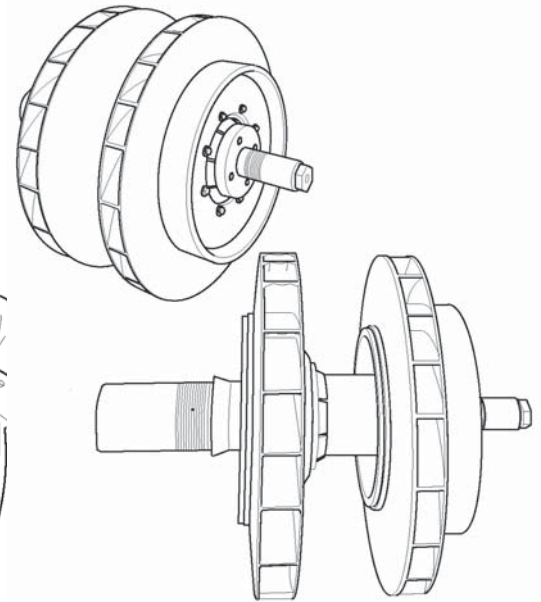


**FIG. 34 – REMOVING FIRST STAGE IMPELLER LABYRINTH SEAL**



***Current production compressors locate the exit plates with roll pins. Some older machines locate the exit diffusers within a circle of machined hex head cap screws. DISTURBING THESE SCREWS WILL MISALIGN THE DIFFUSER EXIT PLATES. Don't rotate the cap screws retaining the exit vanes.***

- B. You may be able to handle the 26" exit plates without rigging, but the 38" and 55" are too heavy and may not be safe. Continue removing successive stages until the first stage entrance diffuser is exposed.
5. The first stage vane entrance diffuser disk (180) and impeller labyrinth seal are solid pieces – not split in half. Before the first stage impeller labyrinth seal (156) can be removed the following should be performed:



**FIG. 35 – ROTOR**

- A. Remove the oil reservoir (See Removing Oil Reservoir, paragraph 5). Use blocks to support the rotor assembly.
- B. Carefully place a rope sling around the rotor assembly (shaft and impellers). Be sure to watch the balance while rigging. With a chain hoist lift out the rotor assembly carefully moving the rotor toward the oil reservoir end until the drive end of the shaft is clear of the PRV assembly, then lift out of casing (see Fig. 35).
6. Remove the first stage labyrinth seal (retaining ring and seal ring) as shown in Fig. 34. This retaining ring (155) has tapered ends and can be removed with a screw driver.
7. Normally, it will not be necessary to remove the first stage diffuser disk. If it becomes necessary to remove this plate, the pre-rotation vane assembly must first be removed as outlined under Removing the Pre-rotation Vane Assembly.

## ASSEMBLING THE COMPRESSOR

Before considering reassembly of the compressor, you must determine what parts are to be reused and what parts are to be replaced. If the compressor is of an early style, check with the nearest YORK office to see what updates are implemented and recommended. Carefully examine all components and try to determine the cause of failure (if a failure prompted the disassembly).

Major cast components seldom require replacement. If bearings have failed radically and spun in the bearing housings, certify the bore diameters. Bearing housings are usually replaced, oil sumps can possibly be salvaged at the OEM's facility. Thrust failure resulting in severe impeller contact can destroy the inlet seals and sometimes cause stress cracks in the diffusers. Standard compressors handling sour hydrocarbon gas or any gas with hydrogen sulfide component may suffer bolt failure due to metal embrittlement. Look for encrustation or buildup of foreign material on the wheels. Deposits of sludge and dirt in the systems may be the root causes of failure, and if not corrected, will cause premature problems again. There should be sufficient precision tools available including but not limited to at least three dial indicators; one standard Starret 196, a .0005: for the oil pump and a long travel, (at least .250"), to measure the rotor axial during assembly, a 6" vernier caliper, direct reading dial if possible, and several sets of feeler gauges with extra leafs in .002" through .008". Inside and outside micrometer sets are also useful.

1. Carefully inspect the rotor. If no apparent damage or excessive runout is detected, it can usually be reused. Look for severe shaft labyrinth rubs, the shaft may be bent or out of balance. If you have good bearings, you can check it with a dial indicator while it's in the casing. If not, you must put the rotor between centers in a lathe. Unbalance may not be detectable. Any rotor repairs must be done at the YORK factory.
2. Certify all shaft journal diameters. Shaft labyrinth seals and balance piston seals will usually show some light contact. If the lands show heavy contact they should be replaced. (See Table 12 for typical clearances.)
3. Inspect all new parts. Be sure they are the correct items. Physically try all bearings on the rotor and in the bearing housings before starting assembly. Check clearances. Fit labyrinth seals around the impellers and shaft. Check clearances with a feeler gauge.

4. Clean all casing parts thoroughly. Pay special attention to the diffuser grooves. Minute particles can displace the diffusers enough to upset the labyrinth clearances. Clean all diffuser parts, using a fine file to carefully dress all surface nicks and burrs. Do not remove excessive amounts of metal.
5. Using the lower casing half as a template, cut and fit the casing flange gasket. This gasket is 1/32" thick +.003" to -.000". Material must be compatible to the refrigerant and oil being used. Use the YORK part number on the as-built print or current production material. Cement the gasket to the lower casing half. (Use YORK Part No. 013-02674-000, 3MSPW77 or equal.)

### Fitting the Rotor

1. Set the first stage diffuser entrance plate in position in the casing. Using the proper thickness compressor ends gasket (27). Install the PRV housing, be sure to slack off the rigging so the PRV rests in the bottom half. Insert at least four screws and tighten them. Check to be sure the casing splitline gasket is a tight fit to the PRV housing gasket. Place the first stage labyrinth seal ring (156) in the diffuser and secure it with the spring retaining washer (155). Install the suction end oil seal and bearing housing. (See Removing Suction End Oil Seal.)



***If proximity probes are used, a special sleeve and mandrel must be used to set the probes and install the bearing housing. See the as-built print for instructions. Do not use the sleeves as a buildup bearing. If you have a used bearing in good condition, use it. If you must use the new bearing, be very careful of the ID surface. Use plenty of Molycote and oil.***

2. Screw guide pins into the casing and fit the correct number of gaskets, (27, 105, 106), over the sump. Install the discharge end oil seal in the sump. (See Replacing Discharge End Oil Seal.) Do not fit the oil reservoir piston ring or discharge end bearing at this time. If proximity probes are used, fit the special sleeve in the sump.
3. Inspect and condition the rotor journals. Using a nylon or equal rope sling, lift the rotor and ease it into the casing. Coat the rotor journals, suction end oil seal, sleeve or bearing, as the case may be, with

Molycote and the appropriate YORK oil. Coat the first stage labyrinth seal ring and the first stage impeller inlet seal area with Molycote and oil. Ease the rotor into the PRV housing until the impeller is ready to enter the seal. Keep the rotor as level as possible and support it with blocks in the casing. Screw the oil sump housing guide pins into the compressor casing.

4. Coat the discharge oil seal and the sleeve, if used, with Molycote and oil. Do not fit the discharge end bearing at this time. Raise the sump and slip it into the compressor casing. Ease the sump over the rotor carefully to minimize contact to the oil seal or sleeve. Slack off the rigging so the sump rests in the housing and tighten a minimum of four screws to secure the sump. Fit the build up or new shaft bearings. The rotor should rotate easily and move axially without resistance. Set up a dial indicator and record the run-out of each impeller, inlet and rim. Fit the compressor drive shaft snug by hand and record the run-out. (See Table 12 for clearances.)
5. Set up the long reach indicator and record the total rotor end float. With the rotor in the full forward position toward the suction, set the indicator to zero and install the thrust bearing and oil pump. (See Replacing Oil Pump Assembly.) Record the rotor drawback as the oil pump is tightened. Measure the shaft seal collar cover recesses to be sure you have sufficient depth for the shaft seal. (See Fig. 16, Table 11 for dimensions.) Adjust the sump housing and PRV sleeve gaskets if needed. Remove the oil pump and thrust bearing, store in a safe place. You are now ready to proceed with installing the balance of the diffusers.

### INSTALLING THE DIFFUSERS

The original YORK manufactured diffuser entrance and exit plates are marked with stage numbers and match marks. Each set of diffusers have specific length cap screws. The width of successive stages can vary due to sideload connection gas flow. It is imperative that you keep the stage diffusers and the dedicated cap screws together as assemblies. If the cap screws are mixed, some will bottom before the exit plates are tight and others will not have the full holding depth.

1. Set up a dial indicator to read the axial travel of the rotor. Locate it at a point where it is not easily disturbed, this will be a reference point during assembly. Position the rotor full toward the suction and set the indicator to zero. Refer to the diffuser dia-

gram, Fig. 31. Note the exit plate splitline relative to the insert pin (184). Units produced prior to 1995 had the roll pin at TDC. Current production has the pin at the split line. Viewing from the sump end, rotate the first stage entrance plate diffuser approximately 45° clockwise to set the exit plate splitline horizontal. Rig the bottom half of the first stage exit plate. Lower it into the casing and lift it in position over the entrance plate. Use the guide studs to help locate the plate. Be sure all cap screws have washers, if required by referring to the drawing. Slip one half of the shaft labyrinth in the exit plate and coat the rotor shaft with Molycote under the seal. Rotate the shaft a few turns to spread the Molycote and set the other half of the shaft labyrinth seal on the bottom half, slightly offset toward the sump. Lower the top half of the exit plate carefully over the shaft labyrinth, push it in place and start the screws. Center the exit plate halves and snug the screws.

2. Be sure the exit plate halves fit flush at the splitline and the outside rim. Select a feeler leaf, approximately one half the minimum clearance, min. 0.005 inch thickness (Table 12). Insert it between the shaft labyrinth seal and the shaft. The feeler must pass freely around the circumference of the shaft. Use a brass drift or a hammer handle to center the exit diffuser halves. When the clearance is satisfactory, recheck to be sure the parting line is flush and tighten the screws to the proper torque. Measure and record the total rotor axial travel measured from zero with the shaft full forward toward the suction. Note the dimension for records after each measurement.
3. Rotate the lower half of the impeller inlet seal into the bottom half of the second stage entrance diffuser. Be sure it is the one cut out for the locking disk. Install the other half in the top diffuser half. Make sure the seals are a matched set. Coat the lands with Molycote and oil. Apply Molycote and oil to the O.D. of the impeller inlet. Screw an eyebolt into the center hole of the bottom diffuser and lift it into position over the impeller. Start one end into the casing groove. Allow it to rest on the impeller. Remove the eyebolt and let it turn into the groove. Exercise care, be sure persons are safely away from the diffuser.



***A pinch hazard is present. The diffuser will drop quickly. Keep clear to avoid injury.***

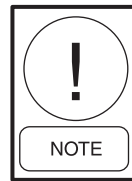
Insert the locking disk, Fig. 4B (Item 74) into the seal recess and set the top half of the entrance plate in position and start one end in the casing groove. Carefully rotate the two halves together approximately 45° clockwise to align the exit plate splitline horizontal and install the exit plate and seals, similar to the first stage. As you install each successive set of diffusers, be sure to center the clearance and recheck the total rotor axial float from your zero and record the figure. It is normal to lose some of your forward travel, do not reset the zero. If you lose more than .040" on a 26" machine or .060" on 38" and 55" units, check to find out why.



***If the space between the diffusers in small machines is too close to permit working, and alternate method of centering the exit diffuser plates is to mount an indicator on the rim of an impeller and read the O.D. of the exit plate. Adjust the position as before until you show concentric within .003".***

4. The exit diffuser for the last stage is a solid disk and the sump must be removed to install it. Remove the discharge end shaft bearing, install the guide pins and dismount the sump. If the compressor has internal vent tubes, align the diffusers and install them at this time. Be careful not to damage the seals at the diffuser. Set the last stage exit plate into the casing, be careful of the shaft journal and tighten the four recessed cap screws. Install the piston ring housing and torque the cap screws. Refer to Installing Balance Piston Seal Ring. Install the seal ring with 75% of the clearance at the top of the assembly, 25% at the bottom of the seal.
5. Lift the sump and install the piston ring. Mount the sump. Refer to Installing the Sump. Fit the shaft and thrust bearings. Record the total float of the rotor after all stages have been installed. Bolt up the oil pump and record the drawback from the full forward position of the rotor after all stages have been installed. You should be approximately 50% back from the suction end. If less than 45% or greater than 55% adjust by changing the sump gaskets. A rotor that is not in center with diffusers may impact performance.

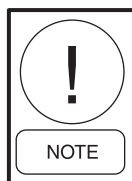
6. Remove the oil pump. Loosen the bolts holding the PRV housing and sump. Slide each of them out approximately 1/4". Tie the gaskets back with thread. Center the roll pins on top of the diffusers with a straight edge and level. Make a reference mark on each diffuser at the casing gasket so you can see if the diffusers shift as the casing is lowered. Current production machines have the diffuser roll pins located at the casing split line. Be sure they are in the slots while lowering the housing top half. Be sure any jackbolts used to raise the top half have been removed. Paint the casing gasket with a release compound or spray teflon. Screw the four guide studs in the lower casing, be sure they do not interfere with the flanges.



***Newer production compressors have the diffuser anti-rotation pins located at the horizontal joint. Pre-1995 compressors used top dead center for diffuser roll pins.***

#### INSTALLING COMPRESSOR CASING TOP HALF

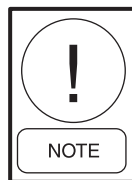
1. When you rig the top half, pick it up flat and level. Lift from a center point with the lines from the casing lugs secured at the hook. Use a come-a-long of appropriate capacity from the hook for precise leveling. As you raise the top half, clean the lower surface. Apply heavy grease or *Never Seize* to the guide studs. Center the casing over the studs and as you lower the top half, rock it gently if necessary. Watch the reference marks and ease off for the last inch. The top casing should sit firmly if the roll pins are aligned. If the diffusers shift as you lower the casing, you may cure the problem by installing jackbolts in the lower casing extending up evenly about an inch. Lower the top half down on the jackbolts and ease it down by gradually turning each bolt one turn at a time until the top half is seated.
2. Clean the dowel pins and dowel pin holes. Install the taper pins. Install the casing bolts hand tight. Starting from the center of both sides, alternately torque two bolts on each side and work toward each end. The torque values are quite high so incremental steps may be utilized (See Compressor drawing). Use a multiplying or hydraulic torque wrench if possible. When all casing bolts are tight, install and torque the remaining PRV and sump cap screws.



***After completion of each torquing procedure check to be sure the compressor still fully rotates freely without drag.***

#### COMPLETION OF COMPRESSOR ASSEMBLY

1. Install the oil pump assembly. (See Replacing Oil Pump Assembly.)
2. Remove the drive shaft and carefully coat the threads with YORK Drive Thread Compound P/N 464-14934 before you install the shaft seal. (See Installing New Shaft Seal.)
3. Complete all internal wiring if proximity probes RTDs or TCs are used. Be sure to deal with proper sealing of the connectors per instructions on the drawing or wrap with teflon tape and seal with heat shrink tubing. Install internal clamps, etc.
4. Install the sump cover and all external oil tubing, pipe and electrical connections.



***Be sure all piping and connections are thoroughly cleaned prior to assembly.***

5. Close all lube oil drains and charge with oil and a new filter.
6. Energize the oil heaters and circulate oil for 15 minutes. Look for leaks. Verify auxiliary oil pump pressure.

#### PREPARATION FOR TEST RUN

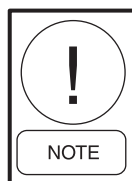
1. Set dial indicators on the compressor shaft to read horizontal and vertical deflection as the suction and discharge flange connections are tightened. Maxi-

mum allowable deflection is +/- .002" total combined. Be sure to install correct flange gaskets.



***Operation without a guard is not recommended. Cordon off area if machine is operated without the guard. Close supervision is required with unprotected shafting.***

2. Install the drive coupling. See YORK coupling instruction for details.
3. Perform leak and vacuum tests in accordance with YORK instructions. Blow down leak test through casing drains if possible.
4. Check the motor and gear lubrication.



***Presence of some oil vapor or smoke from the seal area is normal at initial compressor start. If it persists for more than a few seconds or gets very severe shut down the unit.***

5. Perform "bump-in" procedures. (See Initial Starting – Mechanical Run-In.)
6. Count the oil drops from the seal and compare for the compressor size and speed. Seals with a slightly elevated rate may improve with operational time.
7. Perform hot check for validation alignment.

#### ORDERING REPLACEMENT PARTS

To order replacement parts refer to the job drawing's for all parts including the oil piping. Order parts by their part numbers. Always show the model and the serial numbers of the compressor, and the YORK order number on which the original equipment was furnished.

To obtain parts, contact the nearest YORK Service office.

