

### CONTENTS

Installation, General Comments . . . . .	1
Safety Information and Instructions . . . . .	2
Foundation . . . . .	3
Alignment . . . . .	3
Piping . . . . .	4
Start Up . . . . .	5
Rapid Wear . . . . .	6
Troubleshooting . . . . .	6
Preventative Maintenance . . . . .	7
Do's and Don'ts . . . . .	8

### INSTALLATION GENERAL COMMENTS

Before installation is started, a few items of a general nature should be considered.

- Location** - always locate the pump as close as possible to the supply of liquid to be pumped. Locate it below the liquid supply if at all practical. Viking pumps are self priming but the better the suction conditions the better the performance.
- Accessibility** - the pump should be located where it is accessible for inspection, maintenance, and repair. For large pumps, allow room to remove the rotor and shaft without removing the pump from the base.
- Port Arrangement** - since the pumps have different port arrangements depending on the model, port location should be checked before starting the installation. The ports may be upright, opposite or at right angles to each other, **see Figure 1**. The right angle ports are normally right-hand, **see Figure 2**; some models are available with left-hand arrangements; still other models are available with the right angle ports located in any one of eight positions including right-hand and left-hand.

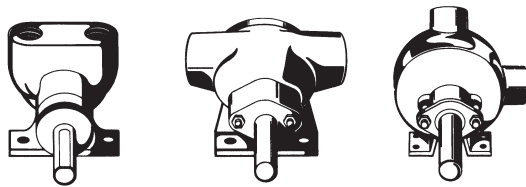

FIGURE 1

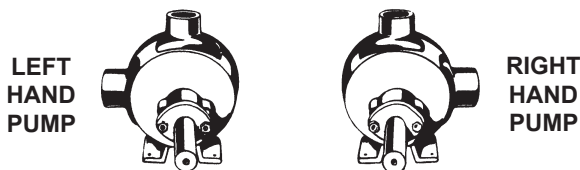

FIGURE 2

- Suction/Discharge** - shaft rotation will determine which port is suction and which is discharge. A look at **Figure 3** will show how rotation determines which port is which; as the pumping elements (gears) come out of mesh, point "A" on **Figure 3**, liquid is drawn into the suction port; as the gears come into

mesh, point "B", the liquid is forced out the discharge port. Reversing the rotation reverses the flow through the pump. When determining shaft rotation, always look from the shaft end of the pump. Unless otherwise specified, rotation is assumed to be clockwise (CW), which makes the suction port on the right side of the pump. The idler pin, which is offset in the pump head, should be properly positioned toward and an equal distance between the port connections.

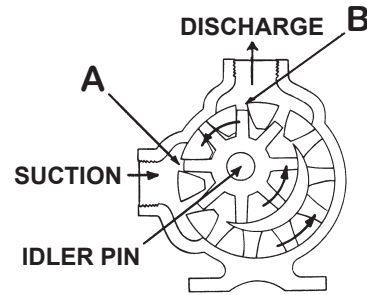

FIGURE 3

- Pressure Protection** - Viking pumps are positive displacement. This means that when the pump is rotated, liquid will be delivered to the discharge side of the pump. If there is no place for this liquid to go - discharge line is blocked or closed - pressure can build up until the motor stalls, the drive equipment fails, a pump part breaks or ruptures, or the piping bursts. Because of this, some form of pressure protection must be used with a positive displacement pump. This may be a relief valve mounted directly on the pump, an inline relief valve, a torque limiting device or a rupture disk.

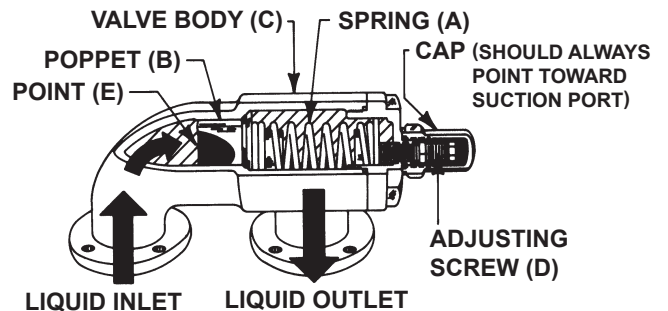

FIGURE 4  
CUTAWAY OF VIKING INTERNAL PRESSURE RELIEF VALVE

The pressure relief valve mounted on Viking pumps and most in-line valves are of the spring loaded poppet design **See Figure 4**. The spring (A) holds poppet (B) against the seat in the valve body (C) with a given force determined by the spring size and by how tightly it is compressed by the adjusting screw (D). The pump discharge pressure pushes against the underside of the poppet at point (E). When the force exerted by the liquid under the poppet exceeds that exerted by the spring, the poppet lifts and liquid starts to flow through the valve. As the discharge pressure builds up, more and more of the liquid flows through until a pressure is reached at which all of the liquid being pumped is going through the valve. This pressure is the relief valve setting.

# SAFETY INFORMATION AND INSTRUCTIONS

IMPROPER INSTALLATION, OPERATION OR MAINTENANCE OF PUMP MAY CAUSE SERIOUS INJURY OR DEATH AND/OR RESULT IN DAMAGE TO PUMP AND/OR OTHER EQUIPMENT. VIKING'S WARRANTY DOES NOT COVER FAILURE DUE TO IMPROPER INSTALLATION, OPERATION OR MAINTENANCE.

THIS INFORMATION MUST BE FULLY READ BEFORE BEGINNING INSTALLATION, OPERATION OR MAINTENANCE OF PUMP AND MUST BE KEPT WITH PUMP. PUMP MUST BE INSTALLED, OPERATED AND MAINTAINED ONLY BY SUITABLY TRAINED AND QUALIFIED PERSONS.

THE FOLLOWING SAFETY INSTRUCTIONS MUST BE FOLLOWED AND ADHERED TO AT ALL TIMES.

Symbol Legend :



**Danger** - Failure to follow the indicated instruction may result in serious injury or death.

**WARNING**

**Warning** - In addition to possible serious injury or death, failure to follow the indicated instruction may cause damage to pump and/or other equipment.



**BEFORE** opening any liquid chamber (pumping chamber, reservoir, relief valve adjusting cap fitting, etc.) be sure that :

- Any pressure in the chamber has been completely vented through the suction or discharge lines or other appropriate openings or connections.
- The pump drive system means (motor, turbine, engine, etc.) has been "locked out" or otherwise been made non-operational so that it cannot be started while work is being done on the pump.
- You know what material the pump has been handling, have obtained a material safety data sheet (MSDS) for the material, and understand and follow all precautions appropriate for the safe handling of the material.

**WARNING**

**INSTALL** pressure gauges/sensors next to the pump suction and discharge connections to monitor pressures.



**WARNING**

**USE** extreme caution when lifting the pump. Suitable lifting devices should be used when appropriate. Lifting eyes installed on the pump must be used **only** to lift the pump, **not** the pump with drive and/or base plate. If the pump is mounted on a base plate, the base plate must be used for all lifting purposes. If slings are used for lifting, they must be safely and securely attached. For weight of the pump alone (which does not include the drive and/or base plate) refer to the Viking Pump product catalog.



**BEFORE** operating the pump, be sure all drive guards are in place.



**DO NOT** attempt to dismantle a pressure relief valve that has not had the spring pressure relieved or is mounted on a pump that is operating.



**DO NOT** operate pump if the suction or discharge piping is not connected.



**AVOID** contact with hot areas of the pump and/or drive. Certain operating conditions, temperature control devices (jackets, heat-tracing, etc.), improper installation, improper operation, and improper maintenance can all cause high temperatures on the pump and/or drive.



**DO NOT** place fingers into the pumping chamber or its connection ports or into any part of the drive train if there is **any possibility** of the pump shafts being rotated.



**WARNING**

**DO NOT** exceed the pumps rated pressure, speed, and temperature, or change the system/duty parameters from those the pump was originally supplied, without confirming its suitability for the new service.



**WARNING**

**THE PUMP** must be provided with pressure protection. This may be provided through a relief valve mounted directly on the pump, an in-line pressure relief valve, a torque limiting device, or a rupture disk. If pump rotation may be reversed during operation, pressure protection must be provided on **both** sides of pump. Relief valve adjusting screw caps must always point towards suction side of the pump. If pump rotation is reversed, position of the relief valve must be changed. Pressure relief valves cannot be used to control pump flow or regulate discharge pressure. For additional information, refer to Viking Pump's Technical Service Manual TSM 000 and Engineering Service Bulletin ESB-31.



**WARNING**

**BEFORE** operating the pump, be sure that:

- It is clean and free from debris
- all valves in the suction and discharge pipelines are fully opened.
- All piping connected to the pump is fully supported and correctly aligned with the pump.
- Pump rotation is correct for the desired direction of flow.



**WARNING**

**THE PUMP** must be installed in a matter that allows safe access for routine maintenance and for inspection during operation to check for leakage and monitor pump operation.

### CAUTION !

Internal type relief valves mounted on Viking pumps should always have the cap or bonnet pointed toward the suction side of the pump. Return-to-tank-type relief valves should always be mounted on the discharge side of the pump. If pump rotation is reversed, change the relief valve. Turn the internal type end for end; move the return-to-tank type to the other port. If, on a particular installation rotation is reversed, e.g., using one pump to fill a tank and then by use of a reversing switch or other means changing the rotation to permit the same pump to circulate the liquid through a heater or to load out) then pressure protection must be provided on both sides of the pump for both rotations. This may be a combination of relief valves, torque limiting devices or rupture disks.

### CAUTION !

Pumps or systems without relief valves should have some form of pressure protection, e.g. torque limiting devices or rupture disks.

Viking pumps can be furnished with either an internal pressure relief valve - one which directs the flow from the valve back to the suction side of the pump - or a return-to-tank valve which directs the flow through piping back to the supply tank. See Figures 5A and 5B. An inline relief valve mounted in the discharge piping also directs the flow back to the supply tank. This type of valve should be mounted close to the pump so that the pressure drop through the piping between the pump and the valve is at a minimum. Be sure there are no shutoff valves between the pump and relief valve. Piping from a return-to-tank or an in-line valve to the supply tank should also be as short and large as possible.

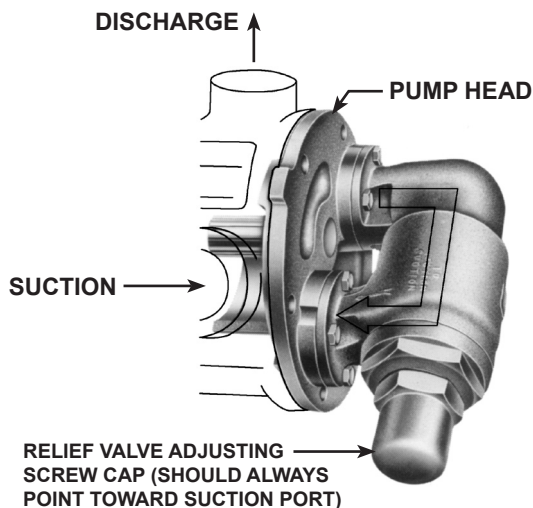

FIGURE 5A  
INTERNAL PRESSURE RELIEF VALVE

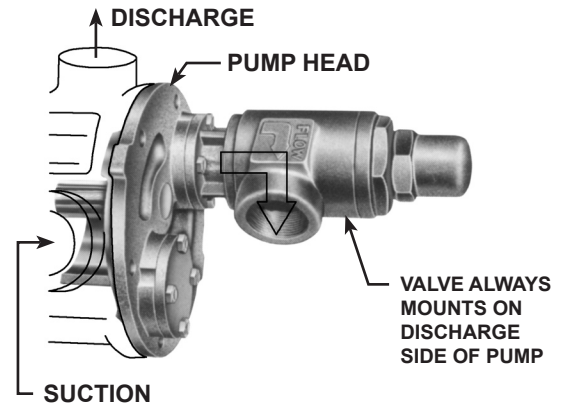

FIGURE 5B  
RETURN-TO-TANK PRESSURE RELIEF VALVE

**NOTE:** on some models the relief valve is mounted on the pump casing instead of the pump head.

The spring loaded poppet-type valve is strictly a differential valve, sensing only those pressures on each side of the poppet. It should not be used as a pressure or flow control device. It is intended strictly as a relief valve.

The pressure at which either the return-to-tank or internal relief valve bypasses can be changed by turning the adjusting screw. Do not back the adjusting screw all the way out. Stop when spring tension is off the screw (the screw starts to turn easily). For details on maintenance of the relief valve see Technical Service Manual covering your model series.

6. **Motor** - follow local electrical codes when hooking up motors.

## FOUNDATION

Every pump should have a solid foundation. It may be any structure sufficiently strong to hold the pump rigid and to absorb any strain or shock that may be encountered.

A certified print of the pumping unit should be used in preparing the foundation. If a separate foundation is provided, make it at least four inches wider and longer than the base of the unit.

When the unit is placed on the foundation it should be leveled and checked for position against the piping layout and then fastened down.

## ALIGNMENT

### CHECK ALIGNMENT AFTER MOUNTING

For detailed coupling alignment procedures see **Viking service bulletin ESB-61**.

The pump, drive, and motor were properly aligned at the time they were assembled. During shipping and mounting the alignment is often disturbed. **BE SURE TO RECHECK ALIGNMENT AFTER THE PUMP UNIT IS INSTALLED!**

1. Check pump ports to be sure they are square and in the proper position; shim or move the pump as required. Do not force piping to line up with the ports.
2. If the pump is driven by a flexible coupling(s) either direct connected to the motor or through a reducer, remove any coupling guards or covers and check alignment of the coupling halves. A straightedge (a piece of key stock works nicely) across the coupling must rest evenly on both rims at the top, bottom, and sides. See Figure 6, page 4.

USE A STRAIGHT EDGE. THESE SURFACES MUST BE PARALLEL.

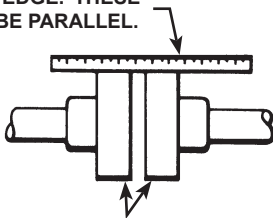

CHECK WIDTH BETWEEN THESE SURFACES WITH INSIDE CALIPERS TO BE CERTAIN THE FACES ARE EQUAL DISTANCE APART AND PARALLEL.

FIGURE 6

3. If the pump is driven by V-belts, check the alignment by using a long straightedge or tightly drawn string across the face of the sheaves. See Figure 6A.

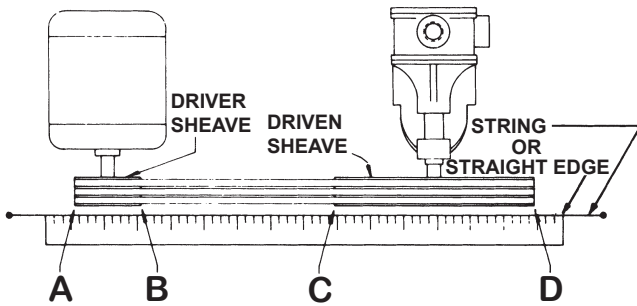

WHEN SHEAVES ARE PROPERLY ALIGNED, ALL POINTS A, B, C, D WILL TOUCH STRING OR STRAIGHT EDGE.

FIGURE 6A

4. Make a final check on alignment after piping is hooked up. See item 13 under "Installation - Piping." Figures 7, 8, and 9 show typical units - direct, gear reducer and V-belt drive.
5. For high temperature applications (those above 300°F) allow the pump to reach operating temperature, then recheck alignment.

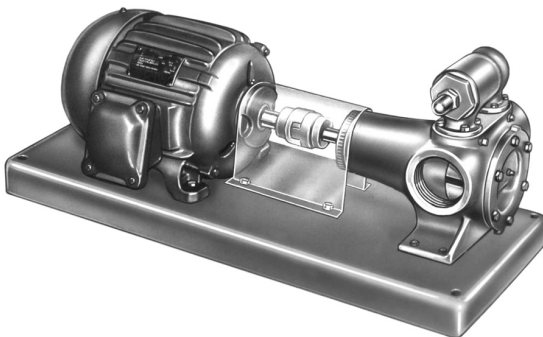

FIGURE 7  
DIRECT DRIVE

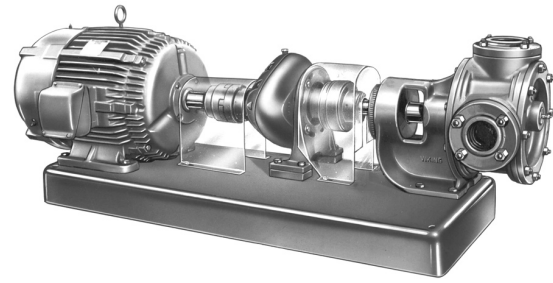

FIGURE 8  
REDUCER DRIVE

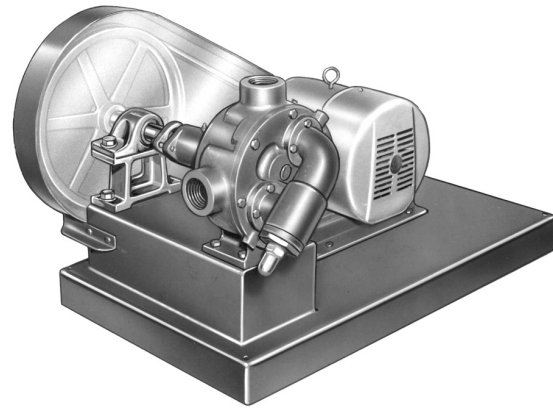

FIGURE 9  
V-BELT DRIVE

## PIPING

The cause of many pumping problems can be traced to suction piping. It should always be as large and short as practical. For help in selecting the proper size piping, both suction and discharge, refer to Viking General Catalog Section 510.

Before starting layout and installation of your piping system, consider the following points:

1. Never use piping smaller than the pump port connections.
2. Be sure the inside of the pipe is clean before hooking it up.
3. **Foot valve** - When pumping a light liquid with a suction lift, a foot valve at the end of the suction piping or a check valve in the first horizontal run will hold the liquid in the line and make it easier for the pump to prime. Be sure the foot or check valve is big enough so that it doesn't cause excessive line loss.
4. When approaching an obstacle in the suction or discharge line, go around the obstacle instead of over it. Going over it creates an air pocket. See Figure 10.
5. Where practical, slope the piping so no air or liquid pockets will be formed. Air pockets in the suction line make it hard for the pump to prime.
6. For a suction line with a long horizontal run keep the horizontal line below the liquid level if possible. This keeps the pipe full so the pump does not have to remove so much air when starting; this is most helpful when there is no foot valve. See Figure 11.
7. When piping a hot or cold system (liquid being handled is at a temperature different from the air surrounding the pump), be sure allowance is made for expansion and contraction of the piping. Loops, expansion joints, or unsecured (this does not mean unsupported) runs should be used so the pump casing is not distorted or put into a bind.

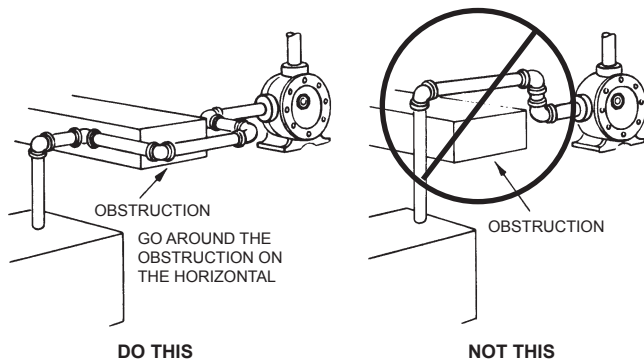

FIGURE 10

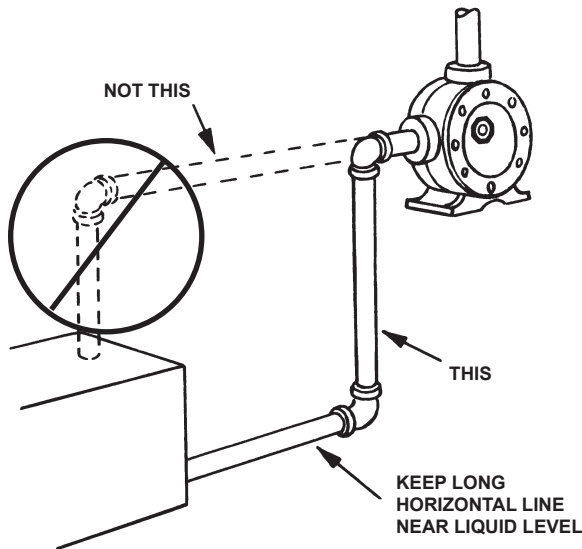

FIGURE 11

8. **STRAINER** - It is always good practice to consider a strainer on the suction side of a positive displacement pump. The strainer will keep foreign objects from going into the pump; without a strainer some would go through; others would cause a jammed pump, a broken part, or a torn up drive. The strainer basket mesh or perforation size should be big enough so that it does not cause excessive pressure drop, but it should be fine enough to protect the pump. When in doubt as to the proper size, check with the manufacturer, giving him pipe size, flow rate, and viscosity involved. Provision should be made for cleaning the strainer. If the pump operates continuously, a bypass should be built around the strainer or two strainers should be put in parallel with proper valving so they can be isolated for cleaning. Use of a strainer is particularly important at start up to help clean the system of weld beads, pipe scale, and other foreign objects. For additional information, refer to TSM640.
9. If the pump is not equipped with a relief valve, consideration should be given to mounting one in the discharge line. See discussion on relief valves under **START UP**.
10. The pump should not be used to support the piping. The weight of the pipe should be carried by hangers, supports, stands, etc.
11. When fastening the piping to the pump it should not be necessary to impose any strain on the pump casing. "Springing" or "drawing" the piping up to the pump will cause distortion, possible misalignment, and probable rapid wear of the pump. Do not use the pump to correct errors in piping layout or assembly.
12. All joints of the piping system should be tight; pipe sealer will

help assure leak-free threaded joints. Leaks in the suction line permitting air to be drawn in may cause a noisy pump, or a reduction in capacity.

13. **ALIGNMENT** - Check the alignment of the drive after the piping is hooked up. As a final check on pump alignment remove the head of the pump and with a feeler gauge determine if there is clearance all the way around between the rotor and casing. Because of manufacturing tolerances, bushing clearances, etc., the rotor may not be centered in the casing, but it should not drag; dragging would indicate unit misalignment or casing distortion from piping strain. Making this check is most desirable on installations involving Q, M and N size standard duty pumps.
14. The auxiliary piping hooked to jackets, glands, etc. for heating, cooling, quenching, or for other purposes should receive the same attention as the piping handling the liquid pumped.
15. Provide a pressure relief device in any part of a pump and piping system that can be valved off and, thus, completely isolated. This is particularly important:
  - a) When handling a cold liquid such as refrigeration ammonia that can warm up to ambient temperatures when the pump is shut off or
  - b) When handling a liquid such as asphalt or molasses that has to be heated before it can be pumped.

The rise in temperature causes the liquid to expand; if there is no provision for pressure relief in the closed off section, there is

## START UP

Before pushing the "start" button, check the following:

1. Are there vacuum and pressure gauges on or near the pump? These gauges are the quickest and most accurate way of finding out what is happening in the pump.
2. Check alignment - See suggestions under "**Installation - Alignment**" in this manual.
3. Check piping to be sure there is no strain on the pump casing.
4. Rotate the pump shaft by hand to be sure it turns freely. **MAKE SURE THE PUMP DRIVER IS LOCKED OUT OR CANNOT BE ENERGIZED BEFORE DOING THIS.**
5. Jog motor to be sure it is turning in the right direction; see discussion on pump rotation under "**Installation - General Comments**" item 4 in this manual.
6. Check any relief valves to be sure they are installed correctly. See discussion on relief valves under "**Installation - General**".
7. Check suction piping to be sure (a) it is all connected and tight, (b) valves are open, and (c) end of pipe is below liquid level.
8. Check discharge piping to be sure (a) it is connected and tight, (b) valves are open, and (c) there is a place for the liquid to go.
9. Lubricate any grease fitting on the pump using a good, general purpose #2 ball bearing grease. Check any gear reducer, motor, coupling, etc. for instructions and lubricate as recommended. **See Engineering Service Bulletin ESB-515.**
10. For packed pumps, loosen packing gland nuts so gland can be moved slightly by hand. Adjust gland to reduce leakage only after pump has run long enough to reach constant temperature. Packing should weep a little to keep it cool and lubricated.
11. Do **not** use the Viking pump to flush, pressure test or prove the system with water. Either remove the pump or run piping around it while flushing or testing. Pumping water, dirty or otherwise, can do more damage in a few minutes than months of normal service.
12. Check to be sure all guards are in place.

13. Now you are ready to push the “start” button - gently.

If the pump begins to deliver liquid within 60 seconds, you’re in business. If it does not, push the “stop” button. Do **not** run the pump longer than one minute without liquid in it; you may damage it. Review the steps just outlined, consider what the suction and discharge gauges indicate, **see page 6**; if everything appears to be in order, put some liquid in the pump, a lubricating liquid is best. This will help it prime.

Push the “start” button again. If nothing is flowing within two minutes, stop the pump. The pump is not a compressor, it will not build up much air pressure; it may be necessary to vent the discharge line until liquid begins to flow.

If the pump still does not deliver, the cause may be one or more of the following:

1. Suction line air leaks; vacuum gauge reading should help determine if this is the problem.
2. End of suction pipe not submerged deep enough in liquid.
3. Suction lift is too great or the suction piping is too small.
4. Liquid is vaporizing in the suction line before it gets to the pump.

**If after consideration of these points it still does not pump, suggest you review again all points given under START UP; read through Troubleshooting in this manual and try again. If it still does not pump, contact your Viking representative.**

## RAPID WEAR

CAUSE		EVIDENCE	POSSIBLE SOLUTION
1.	<b>ABRASIVES</b>	Gouges or marks made by large, hard particles; a rapid wearing away of bushings from very small abrasives similar to pumice; or anything in between.	Flush the system with the pump removed. Install strainer in suction line. Oftentimes after a system has run for a few cycles or a few days, the dirt is pretty well cleaned out and if the pump is rebuilt into good condition, it will then last for a long time.
2.	<b>CORROSION</b>	Rust, pitting or metal appears to be “eaten” away.	Check the Viking General Catalog Liquid List for materials of construction recommendation. Consider weather all of the materials used in pump construction were attacked; consider other materials used in the system to determine how they resisted the liquid. Check to see weather or not the liquid has been contaminated to make it more corrosive than anticipated.
3.	<b>EXCEEDING OPERATING LIMITS</b>	Noisy operation, broken bushings, twisted shaft, parts show evidence of high heat (discoloration).	Review General Catalog for operating limits on particular model involved.
4.	<b>INSUFFICIENT EXTRA CLEARANCE</b>	Pump may stall. Evidence of heavy contact between end of rotor teeth and head or other parts.	Increase end clearance and/or contact you distributor or the factory with details of the application so that information regarding proper extra clearance may be provided.
5.	<b>LACK OF LUBRICATION</b>	Noisy bearings, localized heating at bearings or lip seal, smoke, rapid bushing wear.	Be sure all grease fittings are greased before starting and instructions for lubrication of drive equipment are followed; consider use of auxiliary lubricating equipment.
6.	<b>MISALIGNMENT</b>	Wear on only one part of a surface, e.g., one side of the casing, one side of the packing gland, only a portion of the face of the head.	Double check alignment of drive equipment and piping. Check the alignment under conditions as close to operating conditions as possible.
7.	<b>RUN DRY</b>	Pump stalls because parts have uneven expansion caused by frictional heat; galling between surfaces having relative motion; seal seats and idler pins changing color because of high heat.	Be sure there is liquid in the system at the time of start up. Provide some kind of automatic alarm or shut-off if supply tank runs dry.

## TROUBLESHOOTING

A Viking pump that is properly installed and maintained will give long and satisfactory performance.

**NOTE:** Before making any pump adjustment or opening the pump liquid chamber in any manner, make sure that:

1. any pressure in the pumping chamber has been vented through the suction or discharge lines or other openings provided for this purpose,
2. the driver has been “locked out” so that it cannot inadvertently be started while work is being done on the pump and
3. the pump has been allowed to cool down to the point where there is no chance of anyone being burned.

If trouble does develop, one of the first steps toward finding the difficulty is to *install a vacuum gauge in the suction port and a pressure gauge in the discharge port*. Readings on these gauges often will give a clue as to where to start looking for the trouble.

### Vacuum Gauge - Suction Port

1. **High reading would indicate -**
  - a) Suction line blocked - foot valve stuck, gate valve closed, strainer plugged.
  - b) Liquid too viscous to flow through the piping.
  - c) Lift too high.
  - d) Line too small.
2. **Low reading would indicate -**
  - a) Air leak in suction line.
  - b) End of pipe not in liquid.
  - c) Pump is worn.
  - d) Pump is dry - should be primed.
3. **Fluttering, jumping, or erratic reading -**
  - a) Liquid vaporizing.
  - b) Liquid coming to pump in slugs, possibly an air leak insufficient liquid above the end of the suction pipe.
  - c) Vibrating from cavitation, misalignment, or damage parts.

## Pressure Gauge - Discharge Port

### 1. High reading would indicate -

- a) High viscosity and small and/or long discharge line.
- b) Gate valve partially closed.
- c) Filter plugged.
- d) Vertical head did not consider a high specific gravity liquid.
- e) Line partially plugged from build up on inside of pipe.
- f) Liquid in pipe not up to temperature.
- g) Liquid in pipe has undergone a chemical reaction and has solidified.
- h) Relief Valve set too high.

### 2. Low reading would indicate -

- a) Relief valve set too low.
- b) Relief valve poppet not seating properly.
- c) Bypass around the pump partially open.
- d) Too much extra clearance.
- e) Pump worn.

### 3. Fluttering, jumping, or erratic reading -

- a) Cavitation.
- b) Liquid coming to pump in slugs.
- c) Air leak in suction line.
- d) Vibrating from misalignment or mechanical problems.

### Some of the following may also help pinpoint the problem:

#### A) Pump does not pump.

1. Lost its prime - air leak, low level in tank, foot valve stuck.
2. Suction lift too high.
3. Rotating in wrong direction.
4. Motor does not come up to speed.
5. Suction and discharge valves not open.
6. Strainer clogged.
7. Bypass valve open, relief valve set too low, relief valve poppet stuck open.
8. Pump worn out.
9. Any changes in the liquid system, or operation that would help explain the trouble, e.g. new source of supply, added more lines, inexperienced operators, etc.
10. Too much end clearance.
11. Head position incorrect. **See Fig. 3.**

#### B) Pump starts, then loses its prime.

1. Supply tank empty.
2. Liquid vaporizing in the suction line.
3. Air leaks or air pockets in the suction line; leaking air through packing or mechanical seal.
4. Worn out.

#### C) Pump is noisy.

1. Pump is being starved (heavy liquid cannot get to pump fast enough). Increase suction pipe size or reduce length.
2. Pump is cavitating (liquid vaporizing in the suction line). Increase suction pipe size or reduce length; if pump is above the liquid, raise the liquid level closer to the pump; if the liquid is above the pump, increase the head of liquid.
3. Check alignment.
4. May have a bent shaft or rotor tooth. Straighten or replace.
5. Relief valve chatter; increase pressure setting.
6. May have to anchor base or piping to eliminate or reduce vibration.
7. May be a foreign object trying to get into the pump through the suction port.

#### D) Pump not up to capacity.

1. Starving or cavitating - increase suction pipe size or reduce length.
2. Strainer partially clogged.
3. Air leak in suction piping or along pump shaft.
4. Running too slowly; is motor the correct speed and is it wired up correctly.
5. Bypass line around pump partially open.
6. Relief valve set too low or stuck open.
7. Pump worn out.

8. Too much end clearance.

9. Head position incorrect. **See Fig. 3.**

#### E) Pump takes too much power.

1. Running too fast - Is correct motor speed, reducer ratio, sheave size, etc. being used?
2. Is liquid more viscous than unit sized to handle; heat the liquid, increase the pipe size, slow the pump down, or get a bigger motor.
3. Discharge pressure higher than calculated, check with pressure gauge. Increase size or reduce length of pipe, reduce speed (capacity), or get bigger motor.
4. Packing gland drawn down too tight.
5. Pump misaligned.
6. Extra clearance on pumping elements may not be sufficient for operating conditions. Check parts for evidence of drag or contact in pump and increase clearance where necessary.

#### F) Rapid Wear.

On most applications the pump will operate for many months or years before it gradually loses its ability to deliver capacity or pressure. Examination of such a pump would show a smooth wear pattern on all parts. Rapid wear, occurring in a few minutes, hours or days, shows up as heavy grooving, galling, twisting, breaking or similar severe signs of trouble. **SEE CHART, PAGE 7.**

## PREVENTATIVE MAINTENANCE

Performing a few preventative maintenance procedures will extend the life of your pump and reduce the overall cost of ownership.

**A) Lubrication** - Grease all grease fittings after every 500 hours of operation or after 60 days, whichever occurs first. If service is severe, grease more often. Do it gently with a hand gun. Use a NLGI #2 grease for normal applications. For hot or cold applications use appropriate grease. **See Engineering Service Bulletin ESB-515.**

**B) Packing Adjustment** - Occasional packing adjustment may be required to keep leakage to a slight weep; if impossible to reduce leakage by gentle tightening, replace packing or use different type. See Technical Service Manual on particular model series for details on repacking.

**C) End Clearance Adjustment** - After long service the running clearance between the end of the rotor teeth and the head may have increased through wear to the point where the pump is losing capacity or pressure. Resetting end clearance will normally improve pump performance. See TSM on particular model series for procedure on adjusting end clearance for pump involved.

**D) Examine Internal Parts** - Periodically remove the head, examine idler and bushing and head and pin for wear. Replacing a relatively inexpensive idler bushing and idler pin after only moderate wear will eliminate the need to replace more expensive parts at a later date. See TSM on particular model series for procedure in removing head of the pump. Be sure idler does not slide off idler pin as head is removed and drop and hurt someone or damage the part.

**E) Cleaning the Pump** - A clean pump is easier to inspect, lubricate, adjust, and runs cooler; plus, it looks better.

**F) Storage** - If pump is to be stored, or not used for six months or more, pump must be drained and a light coat of non-detergent SAE 30 weight oil must be applied to all internal pump parts. Lubricate fittings and apply grease to pump shaft extension. Viking suggests rotating pump shaft by hand one complete revolution every 30 days to circulate the oil. Retighten all gasketed joints before using the pump.

### DO'S & DON'TS

Do's and Don'ts for installation, operation, and maintenance of Viking pumps to assure safe, long, trouble-free operation.

#### INSTALLATION -

1. Do install pump as close to supply tank as possible.
2. Do leave working space around the pumping unit.
3. Do use large, short, and straight suction piping.
4. Do install a strainer in the suction line.
5. Do double check alignment after the unit is mounted and piping is hooked up.
6. Do provide a pressure relief valve for the discharge side of the pump.
7. Do cut out the center of gaskets used as port covers on flanged port pumps.
8. Do record pump model number and serial number and file for future reference.

#### OPERATION -

1. Don't run pump at speeds faster than shown in the catalog for your model.
2. Don't require pump to develop pressures higher than those shown in the catalog for your model.
3. Don't operate pumps at temperatures above or below limits shown in the catalog for your pump.
4. Don't operate pumps without all guards being in place.
5. Don't operate pump without a relief valve on the pump or in the discharge piping; be sure valve is mounted and set correctly.
6. Don't exceed catalog limits for temperature and pressures of fluids in jacketed areas of pump.
7. Don't use the pump in a system, which includes a steam blow or an air or vapor blow or purge **without** provision for over-speed shutdown in case the pump starts to act as a turbine and over-speeds the drive.
8. Don't operate the pump with all of the liquid bypassing through a pump mounted internal type relief valve or without any flow of liquid going through the pump for more than a couple of minutes. Operation under either of these conditions may result in a heat build-up in the pump, which could cause hazardous conditions or happenings.

#### MAINTENANCE -

1. Do make sure any pump that has residual system pressure in it or that has handled high vapor pressure liquids, e.g., LP-gas, ammonia, Freons, etc. has been vented through the suction or discharge lines or other openings provided for this purpose.
2. Do make sure that if the pump is still hooked to the driver while maintenance is being performed that the driver has been "locked out" so that it cannot be inadvertently started while work is being done on the pump.
3. Do make sure any pump that has handled a corrosive, flammable, hot, or toxic liquid has been drained, flushed, vented and/or cooled before it is disassembled.
4. Don't drop parts during disassembly, e.g., idler can slip from the pin as the head is removed from the pump; it may drop on your foot, plus, it may get nicked or gouged.

### WARRANTY

Viking warrants all products manufactured by it to be free from defects in workmanship or material for a period of one (1) year from date of startup, provided that in no event shall this warranty extend more than eighteen (18) months from the date of shipment from Viking. If, during said warranty period, any products sold by Viking prove to be defective in workmanship or material under normal use and service, and if such products are returned to Viking's factory at Cedar Falls, Iowa, transportation charges prepaid, and if the products are found by Viking to be defective in workmanship or material, they will be replaced or repaired free of charge, FOB. Cedar Falls, Iowa.

Viking assumes no liability for consequential damages of any kind and the purchaser by acceptance of delivery assumes all liability for the consequences of the use or misuse of Viking products by the purchaser, his employees or others. Viking will assume no field expense for service or parts unless authorized by it in advance.

Equipment and accessories purchased by Viking from outside sources which are incorporated into any Viking product are warranted only to the extent of and by the original manufacturer's warranty or guarantee, if any.

THIS IS VIKING'S SOLE WARRANTY AND IS IN LIEU OF ALL OTHER WARRANTIES, EXPRESSED OR IMPLIED, WHICH ARE HEREBY EXCLUDED, INCLUDING IN PARTICULAR ALL WARRANTIES OF MERCHANTABILITY OR FITNESS FOR A PARTICULAR PURPOSE. No officer or employee of IDEX Corporation or Viking Pump, Inc. is authorized to alter this warranty.

5. Don't stick fingers in the ports of a pump! Serious injury may result.
6. Don't spin the idler on the idler pin! Fingers may be jammed between teeth and crescent.
7. Do remember that a few simple preventative maintenance procedures such as periodic lubrication, adjustment of end clearance, examination of internal parts, etc., will extend the service life of your pump.
8. Do **obtain**, read and keep maintenance instructions furnished with your pump.
9. Do have spare parts, pumps or standby units available, particularly if the pump is an essential part of a key operation or process.