

Vibracon[®] Installation Procedure

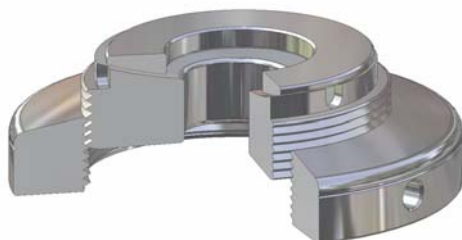
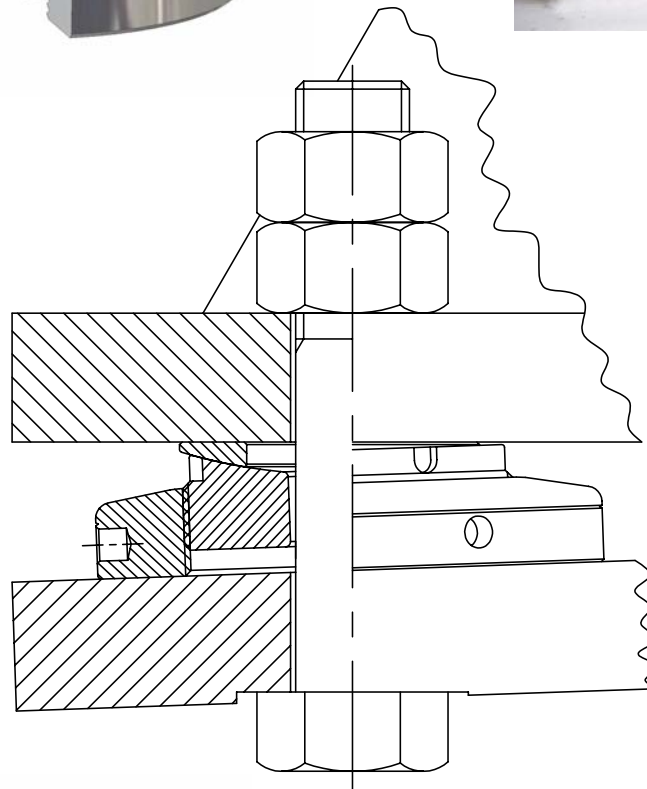
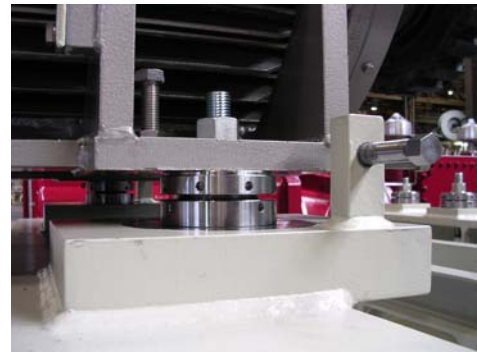

4 **Vibracon® Installation Procedure**

- Step 1** Check foundation quality
- The bottom ring area of the Vibracon® chock should be covered by the foundation for 100%. The spherical top part of the chock must have at least 75% contact with machine foot.
 - Foundation roughness should be sandblasted quality of Sa 2.5 minimum or machined Ra 6.3
 - The contact surface between foundation and bottom ring of the Vibracon® chock should be checked using the bottom ring of the element, until an evenly distributed bearing surface of a minimum which is given by the machinery manufacturer or classification society. In all other cases, we recommend a minimum bearing surface of 75 %.
 - The taper between foundation and machine feet should be less than 4°.
 - Foundation and machine foot should be free from paint and grease.

- Step 2** The Vibracon® chocks' thread and spherical layers are protected with Molykote®. The chocks are ready for installation directly from the package!

Machine Support recommends the use of:

- Molykote® type P37 on the screw thread;
- Molykote® type TP42 on the convex / concave mating surface.

- Step 3** Check if the Vibracon® chock is placed concentric with the bolt hole.

- Step 4** Align the machine.

- Keep in mind while aligning the machine to add 0.10 mm (0.004") to the target alignment because of the fact that the Vibracon® chock will lose height at the moment the foundation bolts are secured. This will happen only the first time the chock is used because of the grease inside of the thread.
- Please remember: Vibracon® chocks are not designed for lifting machinery!
- Height change after 1 cycle (pitch):

SM12	1 mm	0.039"
SM16	1.5 mm	0.059"
SM20 / SM42	2 mm	0.078"
SM48 / SM64	3 mm	0.118"

- Step 5** Tighten the foundation bolts. Machine Support recommends doing this in two steps.

- Step 6** During or after tightening of the foundation bolts recheck the alignment and check for "soft foot". A "soft foot" occurs if one or more of the Vibracon® chocks are not carrying the same load as the other elements.

- Step 7** After installing the machinery apply corrosion protection to the chock by painting or alternative method.

- Step 8** The bolt tension must be checked after the test run.

Machine Support recommends the use of spherical washers in the bolt connection.

If you have any questions, please contact Machine Support.

Phone: +31 (0)180 48 38 28